



**TRANE**<sup>®</sup>



## Agility<sup>™</sup> Centrifugal Chillers

*Efficient, reliable and sustainable performance  
in a compact footprint.*

**LET'S GO BEYOND<sup>™</sup>**

**IR** Ingersoll Rand.

# AGILITY CENTRIFUGAL CHILLERS



## ENHANCED BUILDING COMFORT AND EFFICIENCY FOR A WIDE RANGE OF APPLICATIONS AND BEYOND.

Trane works hard to maximize the performance of buildings all over the world. The new Trane® Agility™ chillers continue that commitment by providing a solution that is compact and environmentally sustainable. Combining that with the efficiency and reliability of Trane, these chillers meet a wide range of rigorous conditions by optimizing compressor technology to meet your cooling demands. Exactly what you'd expect from Trane.

### Compact size ideal for easier installation

Agility's compact design makes it ideal for buildings where space is a premium. The Trane proprietary next-generation, compact, high-performance, integrated, low-charge (CHIL™) evaporators provide the latest in heat exchanger technology that reduces size by up to 25 percent as compared to other medium pressure heat exchangers available on the market today.

With its compact size, Agility easily fits through a set of standard 72-inch-wide by 80-inch-tall double doors with no disassembly required. For a single 36-inch door passage, Agility only needs to be disassembled into two sections, as compared to other chillers that may require being disassembled into four or more pieces. This size advantage means faster and easier installation, saving both time and money.

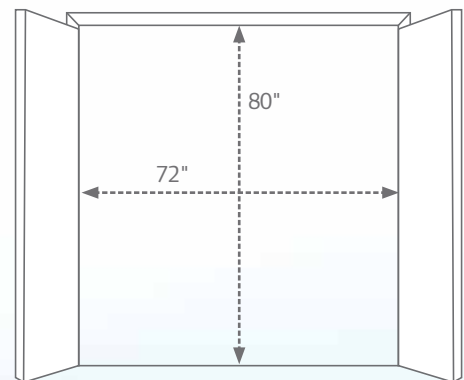

*Agility chillers can easily fit through a set of standard double doors.*



### Trane reliability

With a completely new Trane design, Agility chillers feature advanced oil-free, magnetic-bearing compressor technology and an industry-leading, next-generation heat exchanger design. These are enhanced by Trane controls expertise, creating unsurpassed reliability backed by an industry-leading warranty.

- An innovative 2-stage, speed optimized compressor delivering the widest operating map available in its class covering both AHRI® and non-AHRI conditions
- Opposing impeller placement to balance thrust loads on the driveline, increasing efficiency and delivering greater reliability over the life of the chiller
- Combining the latest in Trane controls, drive technology and an onboard UPS system to ensure a stable and reliable operation of high-speed compressors over the life of the chiller

### More economical cooling

Outstanding full- and part-load efficiencies along with greater compressor serviceability make Agility chillers a more cost-effective cooling solution. With an IPLV rating 40 percent higher than the ASHRAE® 90.1-2016 requirement, Agility can help lower electrical consumption (kWh, part load) and demand charges (kW, highly loaded), contributing to lower operating expenses. Simple tools such as myPLV® are available to help quickly estimate future chiller performance based on project-specific conditions that include location, building type, building load, number and size of the chillers in the plant, chiller condenser control strategy and more.



**For further building optimization, take advantage of connected technology with Intelligent Services and enable 24/7/365 system monitoring analytics for improved energy efficiency, higher reliability and reduced operating costs.**



### Environmental sustainability

Part of the EcoWise™ portfolio, Trane Agility chillers are energy efficient and can operate using R-513A, a next-generation, low GWP refrigerant designed to lower environmental impact without compromising performance, safety and reliability. Better full-load efficiencies lend themselves to lower demand charges and smaller electrical infrastructures. Better part-load efficiencies provide overall lower consumption charges. Reducing energy consumption across the board lowers the indirect impact your chiller has on the environment.

CHIL™ evaporator design optimizes refrigerant flow with an industry leading up to 25 percent lower refrigerant charge as compared to other medium pressure chillers on the market today. In addition, the heat exchanger design includes a super sub cooler that gives improved efficiency and lowers energy consumption over the life of the chiller.

**Visit [Trane.com/Agility](http://Trane.com/Agility)  
to learn more.**



Ingersoll Rand (NYSE:IR) advances the quality of life by creating comfortable, sustainable and efficient environments. Our people and our family of brands—including Club Car®, Ingersoll Rand®, Thermo King® and Trane®—work together to enhance the quality and comfort of air in homes and buildings; transport and protect food and perishables; and increase industrial productivity and efficiency. We are a \$13 billion global business committed to a world of sustainable progress and enduring results.



Trane, the Circle Logo, Let's Go Beyond, Agility, CHIL, myPLV and EcoWise are trademarks of Trane in the United States and other countries. ASHRAE is a registered trademark of the American Society of Heating, Refrigerating, and Air-Conditioning Engineers, Inc. AHRI is a registered trademark of Air-Conditioning, Heating and Refrigeration Institute, Inc. All trademarks referenced in this document are the trademarks of their respective owners.

[ingersollrand.com](http://ingersollrand.com)