



Product Catalog

**AdaptiR™**

**Helical Rotary Liquid Chillers**

Model RTHD with

Adaptive Frequency™ Drive

150~450 Tons (50 Hz),

150~425 Tons (60 Hz)



August 2021

**RTHD-PRC004G-EN**

**TRANE**  
TECHNOLOGIES

# Table of Contents

<b>Introduction</b> .....	<b>3</b>
<b>Features and Benefits</b> .....	<b>4</b>
<b>Options</b> .....	<b>6</b>
<b>Controls</b> .....	<b>8</b>
<b>Application Considerations</b> .....	<b>14</b>
<b>Selection Procedure</b> .....	<b>16</b>
<b>Model Number Description</b> .....	<b>18</b>
<b>General Data</b> .....	<b>20</b>
<b>Electrical Data and Connections</b> .....	<b>23</b>
<b>Dimensions</b> .....	<b>32</b>
<b>Mechanical Specifications</b> .....	<b>34</b>

# Introduction

To meet the increasing demand for superior full load and part load performance under varying condition and diverse application, Trane is proud to introduce model AdaptiR™ with Adaptive Frequency™ Drive (AFD) and variable volume ratio helical rotary liquid chiller. The introduction of this offering chiller is an exciting step of forward in enhancing energy-efficiency, operational cost-effectiveness, application versatility, ease of installation, control precision and reliability. The new chiller is designed to deliver proven Series R performance, plus the benefits of improved part load performance and reduced in-rush current associated with AFD.

AFD and variable volume ratio on screw compressors, being volume displacement type, operates well under part load at constant tower temperature or temp relief. And it is easy to do retrofit on current RTHD.

## Important Design Advances and New Features

Major design advances include:

- High system IPLV and part load efficiency, with IPLV at most to 11.1, to reduce annual operating and lifecycle costs. Compared with fixed speed chiller designs, the AdaptiR™ with AFD offers a part-load efficiency improvement of 17-39% while maintaining the same COP efficiency level. Compared with AdaptiR™ with AFD models, the variable volume ratio chillers with D4 compressor offer a further partload efficiency improvement of ~20%.
- Optimized falling film evaporator bundle design, almost no carryover. More efficient oil separator, the efficiency can reach to 99.98%. Robust thermosyphon oil return device make unit higher reliability. Electronic modulated valve make chiller always run above the reliable frequency, higher bearing reliability. Direct motor temperature monitor and protection logic, safer motor operation.
- UC800 controls and TD7 LCD touch screen display enable:
  - Providing better AFD speed adjustment control by embedded industry-leading control algorithms;
  - Simplifying chiller operation with the BACnet™, ModBus™ and LonTalk™ capability without the need for gateways;
  - Scrolling access to inputs and operating information via the LCD touch-screen display which uses full text display available in 26 language;
  - Providing ease of interoperability with LonMark Communication;
  - Job-specific communication options that allow greater reporting flexibility.
- AdaptiR™ with AFD / variable volume ratio features low sound pressure level in part load. The reduced speed during part-load significantly reduces sound level. Optional sound wrap provides further sound attenuation. The quiet performance brings a comfortable environment to the chiller plant, making it a perfect choice for those noise sensitive installations such as libraries, schools, hospitals.
- The communicated Trane AFD for variable volume ratio chillers has more precise control and more information display.
- The Trane AFD is integrated with an AC-link reactor to minimize line harmonics to less than 40% total harmonic distortion (THDi); Low Harmonic filter is optional to meet IEEE 519 with input of AFD, reducing harmonic distortion to less than 5% THD, thus further reducing the impact on the grid. In addition, Trane AFD soft-start minimizes inrush current, thereby protecting other electrical or electronics devices sharing the same power grid.

The industrial-grade design of the AdaptiR™ helical rotary chiller and its versatile operation capability make it an ideal choice for a wide spectrum of buildings. such as industrial plants, commercial/office buildings, hospitals, hotel and schools. The variable speed drive, linear unloading compressor, wide operating temperature range, advanced controls, electronic expansion valve, short anti-recycle timers, and industry-leading efficiencies make Trane AdaptiR™ the preferred choice for applications requiring tight temperature control under varying load condition.



# Features and Benefits

## Application Versatility and High Performance

- Trane Adaptive Frequency™ drive - a customized version of AFD series.
- Adaptive Frequency™ Drive ensures a quiet environment with the sound pressure level as low as to 72 dBA under most part-load condition.
- Screw compressor technology and the electronic expansion valve provide reliable performance in an expanded range of operating temperatures.
- Variable volume ratio technology application provide industry-leading part load efficiency.
- Tight water temperature control extends to operation of multiple chillers in parallel or series configurations, offering further system design flexibility for maximum efficiency.
- Advanced design enables chilled water temperature control to +/- 0.5°F (.28°C) for flow changes up to 10 percent per minute (flow changes up to 30 percent per minute for comfort cooling).
- Two-minute stop-to-start and five-minute start-to-start anti-recycle timer allows tight chilled water temperature control in constant or transient low-load applications.
- LonMark communications capability provides excellent, trouble-free interoperability.
- Generic Building Automation System points are available for easy access to operational information.
- Extensive information on professional design selection and layout is available in a simple, highly readable electronic format.

## Simple, Economical Installation

- Compact size makes the AdaptiR™ RTHD with AFD / variable volume ratio model well suited for the retrofit and replacement market.
- All units fit through standard double-width doors with disassemble of the panel.
- Integrated drive with advanced control panel to decrease field setup work.
- Bolt-together construction makes for fast, easy unit disassembly.
- Small footprint saves valuable equipment room space and alleviates access concerns for most retrofit jobs.
- Light weight design simplifies rigging requirements, further reducing installation time requirements and costs.
- Only evaporator and condenser water piping is required; no starter water cooling (with its associated safety concerns) or field piping is necessary.
- Simple power connection simplifies overall installation.
- Trane has conducted extensive factory testing, and also offers options for in-person and/or documented system performance verification.

## State-of-the-Art, Precision Control

- The communicated drive for variable volume ratio models have more precise control and more information display.
- Microprocessor UC800 controls monitor and maintain optimal operation of the chiller and its associated sensors, actuators, relays, and switches, all of which are factory-assembled and extensively tested.
- Optional harmonic filtration system provides the harmonic solution to meet the requirements of IEEE 519 with input of AFD, reducing harmonic distortion to less than 5 percent total total harmonic distortion, which also provides filter over-temperature protection and capacitors disconnect.
- Adaptive Frequency™ Drive provides soft start to minimize inrush current and is integrated with AC line reactor to minimize line harmonics.
- Easy interface with computers hosting Tracer Summit™ building automation/energy management systems allows the operator to efficiently optimize comfort system performance and minimize operating costs.

- PID (proportional integral derivative) control strategy ensures stable, efficient chilled water temperature control, maintaining +/-1°F (0.56°C) control by proactively reacting to instantaneous load changes of up to 50 percent.
- Adaptive Control™ attempts to maintain chiller operation under adverse conditions, when many other chillers might simply shut down.
- Easy-to-use operator interface displays all operating and safety messages, with complete diagnostics information, on a highly readable panel with a scrolling touch-screen display.
- The AdaptiR™ RTHD with AFD / variable volume ratio features a complete range of chiller safety controls.
- Over 120 diagnostic and operating points are available, with standard displays including chiller current draw, condenser pressure, and evaporator pressure.

## **Reliability and Ease of Maintenance**

- Direct drive, low-speed compressor – a simple design with only three moving parts – provides maximum efficiency, high reliability, and low maintenance requirements.
- Electronic expansion valve, with fewer moving parts than alternative valve designs, offers highly reliable operation.
- Suction gas-cooled motor stays uniformly cool at lower temperature for longer motor life.
- The Trane helical rotary compressor is a proven design resulting from years of research and thousands of test hours, including extensive testing under extraordinarily severe operating conditions.
- Trane is the world's leading manufacturer of large helical rotary compressors, with tens of thousands of commercial and industrial installations worldwide demonstrating a reliability rate of greater than 99 percent in the first year of operation.

## **Operating and Life Cycle Cost-Effectiveness**

- Electronic expansion valve enables exceptionally tight temperature control and extremely low superheat, resulting in more efficient full-load and part-load operation than previously available.
- Precise compressor rotor tip clearance ensures optimal efficiency.
- Variable volume ratio technology provide industry-leading part load efficiency.
- Condenser and evaporator tubes use the latest heat transfer technology for increased efficiency.
- The RTHD AFD includes optional electrical demand limiting.
- Chilled water reset based on return water temperature is standard.
- High compressor lift capabilities and tight chilled water temperature control allow highly efficient system design with minimal operational concerns.

## **Design capabilities include:**

- Variable primary flow;
- Series chiller arrangements for evaporator and/or condenser;
- Low evaporator and condenser flow.



## Options

### Insulation

All low temperature surfaces are covered with factory installed 3/4 inch (19.05 mm) Armaflex II or equal (k=0.28) insulation, including the evaporator and water boxes, suction line, and motor housing. 3/8" foam insulation is used on the liquid level sensor and gas pump assembly, including piping.

### Refrigerant Isolation Valves

Factory-installed condenser inlet and outlet refrigerant valves allow isolation of the full refrigerant charge in the condenser while servicing the chiller.

### 300 psig Evaporator and Condenser Water Boxes

Water boxes are designed for 300 psig maximum waterside working pressure, and flange connections are provided for ease of installation.

### 2-Way Condenser Water Regulating Valve

For water regulation, a field-installed, 2-way butterfly-type (lug-style) valve, with integral electrical operator and factory-mounted valve actuator, is available. The single-phase, reversible motor can be factory-wired for 220 VAC, 50 Hz; the 2-way valve is fieldwired and controlled by the chiller regulating valve control output; valves are available in 6" and 8" (152.4 and 203.2 mm) sizes.

### Nitrogen Charge

Unit is shipped with a nitrogen holding charge in lieu of refrigerant.

### Seal Kit for Reassembly

Ideal for situations when the bolt-together construction of the RTHD will be separated for installation, this seal kit provides replacement gaskets and rings for reassembly.

### Under/Over-Voltage Protection

Unit receives protection against variations in voltage (current lag and spike protection is standard).

### Performance and Witness Tests

AHRI-certified RTHD Performance and Witness Tests are available, based on requested operating points, to certify chiller performance before delivery.

### Harmonic Filter

Harmonic filter provides the harmonic solution to meet the requirements of IEEE 519 with input of AFD, reducing harmonic distortion to less than 5 percent total harmonic distortion (THD).

### Sound Wrap

Sound insulation material applied on discharge line is used to attenuate the tone of discharge pipe resonance and the total sound pressure level of unit.

## Main Power Disconnect Options:

### Standard Interrupting Capacity Circuit Breaker

A standard interrupting molded case capacity circuit breaker, factory pre-wired with terminal block power connections and equipped with a lockable external operator handle, is available to disconnect the chiller from main power.

**Control Options:****Tracer Summit Communications**

Link to factory-installed, tested communication board, via single twisted-pair wiring, adds Tracer Summit communications to the system.

**LonTalk LCI-C Interface**

LonTalk (LCI-C) communications capabilities are available, with communication link via single twisted pair wiring to factory-installed, tested communication board.

**External Chilled Water Setpoint**

External Chilled Water Setpoint is communicated to a factory-installed, tested communication board through a 2-10 V DC or 4-20 mA signal.

**External Current Limiting**

External Current Limit Setpoint is communicated to a factory-installed, tested communication board through a 2-10 V DC or 4-20 mA signal.

**External Base Loading**

External Base Loading is communicated to a factory-installed and tested communication board through a 2-10 V DC or 4-20 mA signal.

**Chilled Water Reset – Outdoor Air Temperature**

Controls, sensors, and safeties allow reset of chilled water temperature, based on temperature signal, during periods of low outdoor air temperature (chilled water reset based on return chilled water temperature is standard).

**Condenser-Regulating Valve Control**

Chiller applies a Proportional Integrative Control (PID) algorithm to control water regulating valve via 0-10 V DC signal.

**Percent of Full Run Load Amps Output**

Control system indicates the active chiller percent of full run load amps, based on a 0-10 V DC signal.

**Condenser Pressure Output**

Control system indicates chiller differential pressure or condenser pressure, based on a 0-10 V DC signal.



# Controls

## Tracer UC800 Controller

Today's chillers offer predictive controls that anticipate and compensate for load changes. Other control strategies made possible with the Tracer UC800 controls are:

### Feedforward Adaptive Control

Feedforward is an open-loop, predictive control strategy designed to anticipate and compensate for load changes. It uses evaporator entering-water temperature as an indication of load change. This allows the controller to respond faster and maintain stable leaving-water temperatures.

### Soft Loading

The chiller controller uses soft loading except during manual operation. Large adjustments due to load or setpoint changes are made gradually, preventing the compressor from cycling unnecessarily. It does this by internally filtering the setpoints to avoid reaching the differential-to-stop or the demand limit. Soft loading applies to the leaving chilled-water temperature and demand limit setpoints.

### Adaptive Controls

There are many objectives that the controller must meet, but it cannot satisfy more than one objective at a time. Typically, the controller's primary objective is to maintain the evaporator leaving water temperature.

Whenever the controller senses that it can no longer meet its primary objective without triggering a protective shutdown, it focuses on the most critical secondary objective. When the secondary objective is no longer critical, the controller reverts to its primary objective.

### Rapid Restart

The controller allows the chiller to perform a Rapid Restart. A Rapid Restart is performed after a momentary power loss occurs during operation. Similarly, if the chiller shuts down on a non-latching diagnostic and the diagnostic later clears itself, a Rapid Restart will be initiated.

### Adaptive Frequency Control

Compressor speed is used to control capacity of the chiller, optimizing compressor performance. The advanced UC800 Controller allows the chiller to operate at optimal efficiency, and with greater stability in capacity regulation.

### Variable-Primary Flow (VPF)

Chilled-water systems that vary the water flow through chiller evaporators have caught the attention of engineers, contractors, building owners, and operators. Varying the water flow reduces the energy consumed by pumps, while having limited effect on the chiller energy consumption. This strategy can be a significant source of energy savings, depending on the application.



## **AdaptiViewTD7 Operator Interface**

The standard AdaptiView™TD7 display provided with the Trane UC800 controller features a 7" LCD touch-screen, allowing access to all operational inputs and outputs. This is an advanced interface that allows the user to access any important information concerning setpoints, active temperatures, modes, electrical data, pressure, and diagnostics. It uses full text display available in 26 languages.

### **Display Features Include:**

- LCD touch-screen with LED backlighting, for scrolling access to input and output operating information
- Single-screen, folder/tab-style display of all available information on individual components (evaporator, condenser, compressor, etc. )
- Manual override indication
- Password entry/lockout system to enable or disable display
- Automatic and immediate stop capabilities for standard or immediate manual shutdown
- Fast, easy access to available chiller data in tabbed format, including:
  - Easy to view Operating Modes
  - Logical Sub-Component Reports:
    - Evaporator
    - Condenser
    - Compressor
    - Motor
  - 3 User Programmable Custom Reports
  - ASHRAE report
  - Logsheets Report
  - Alarms Report
  - 8 pre-defined Standard Graphs
  - 4 User Programmable Custom Graphs
  - Chiller Settings
  - Feature Settings
  - Chilled Water Reset
  - Manual Control Settings
  - Globalization Settings
  - Support of 26 languages
  - Brightness Setting
  - Cleaning Mode

### TracerTU Interface

TracerTU (utility software) adds a level of sophistication that improves service technician effectiveness and minimizes chiller downtime. The Tracer AdaptiView control's operator interface is intended to serve only typical daily tasks. The portable PC-based service-tool software, TracerTU, supports service and maintenance tasks. TracerTU serves as a common interface to all Trane® chillers, and will customize itself based on the properties of the chiller with which it is communicating. Thus, the service technician learns only one service interface.

The panel bus is easy to troubleshoot using LED sensor verification. Only the defective device is replaced. TracerTU can communicate with individual devices or groups of devices.

All chiller status, machine configuration settings, customizable limits, and up to 100 active or historic diagnostics are displayed through the service-tool software interface.

LEDs and their respective TracerTU indicators visually confirm the availability of each connected sensor, relay, and actuator.

TracerTU is designed to run on a customer's laptop, connected to the Tracer AdaptiView control panel with a USB cable. Your laptop must meet the following hardware and software requirements:

- 1 GB RAM (minimum)
- 1024 x 768 screen resolution
- CD-ROM drive
- Ethernet 10/100 LAN card
- An available USB 2.0 port
- Microsoft® Windows® XP Professional operation system with Service Pack 3 (SP3) or Windows 7 Enterprise or Professional operating system (32-bit or 64-bit)
- Microsoft .NET Framework 4.0 or later

**Note:** *TracerTU is designed and validated for this minimum laptop configuration. Any variation from this configuration may have different results. Therefore, support for TracerTU is limited to only those laptops with the configuration previously specified.*

## System Integration

### Stand-Alone Controls

Single chillers installed in applications without a building management system are simple to install and control: only a remote auto/stop for scheduling is required for unit operation. Signals from the chilled-water pump contactor auxiliary, or a flow switch, are wired to the chilled-water flow interlock. Signals from a time clock or some other remote device are wired to the external auto/stop input.

- Auto/Stop-A job-site provided contact closure turns the unit on and off.
- Emergency Stop-A job-site provided contact opening wired to this input turns the unit off and requires a manual reset of the unit microcomputer. This closure is typically triggered by a job-site provided system such as a fire alarm.

### Hardwire Points

Microcomputer controls allow simple interface with other control systems, such as time clocks, building automation systems. This means you have the flexibility to meet job requirements while not having to learn a complicated control system.

Remote devices are wired from the control panel to provide auxiliary control to a building automation system. Inputs and outputs can be communicated via a typical 4–20 mA electrical signal, an equivalent 2–10 V DC signal, or by utilizing contact closures.

This setup has the same features as a stand-alone water chiller, with the possibility of having additional optional features:

- External chilled water setpoint, external demand limit setpoint
- Chilled water temperature reset
- Programmable relays - available outputs are: alarm-latching, alarm-auto reset, general alarm, warning, chiller limit mode, compressor running, and Tracer control.

### BACnet Interface

Tracer AdaptiView control can be configured for BACnet communications at the factory or in the field. This enables the chiller controller to communicate on a BACnet MS/TP network. Chiller setpoints, operating modes, alarms, and status can be monitored and controlled through BACnet.

Tracer AdaptiView controls conform to the BACnet B-ASC profile as defined by ASHRAE 135-2004.

### LonTalk Communications Interface (LCI-C)

The optional LonTalk® Communications Interface for Chillers (LCI-C) is available factory or field installed. It is an integrated communication board that enables the chiller controller to communicate over a LonTalk network. The LCI-C is capable of controlling and monitoring chiller setpoints, operating modes, alarms, and status. The Trane LCI-C provides additional points beyond the standard LONMARK® defined chiller profile to extend interoperability and support a broader range of system applications. These added points are referred to as open extensions. The LCI-C is certified to the LONMARK Chiller Controller Functional Profile 8040 version 1.0, and follows LonTalk FTT-10A free topology communications.

### Modbus Interface

Tracer AdaptiView control can be configured for Modbus communications at the factory or in the field. This enables the chiller controller to communicate as a slave device on a Modbus network.

Chiller setpoints, operating modes, alarms, and status can be monitored and controlled by a Modbus master device.

## Tracer Summit

The chiller plant control capabilities of the Trane Tracer Summit™ building automation system are unequalled in the industry. Trane's depth of experience in chillers and controls makes us a wellqualified choice for automation of chiller plants using chillers. Our chiller plant automation software is fully pre-engineered and tested.

Required features:

- LonTalk/Tracer Summit Interface (selectable option with chiller)
- Building Control Unit (external device required)

Energy Efficiency

- Sequences starting of chillers to optimize the overall chiller plant energy efficiency
  - Individual chillers operate as base, peak, or swing based on capacity and efficiency
  - Automatically rotates individual chiller operation to equalize runtime and wear between chillers.
  - Evaluates and selects the lowest energy consumption alternative from an overall system perspective.

Regulatory Compliance Documentation

- Gathers information and generates the reports mandated in ASHRAE Guideline 3.

Easy Operation and Maintenance

- Remote monitoring and control
- Displays both current operation conditions and scheduled automated control actions
- Concise reports assist in planning for preventative maintenance and verifying performance
- Alarm notification and diagnostic messages aid in quick and accurate troubleshooting

## Tracer SC

The Tracer SC™ system controller acts as the central coordinator for all individual equipment devices on a Tracer building automation system. The Tracer SC scans all unit controllers to update information and coordinate building control, including building subsystems such as VAV and chiller water systems. With this system option, the full breadth of Trane's HVAC and controls experience are applied to offer solutions to many facility issues. The LAN allows building operators to manage these varied components as one system from any personal computer with web access.

The benefits of this system are:

- Improved usability with automatic data collection, enhanced data logging, easier to create graphics, simpler navigation, pre-programmed scheduling, reporting, and alarm logs.
- Flexible technology allows for system sizes from 30-120 unit controllers with any combination of LonTalk or BACnet unit controllers.
- LEED certification through site commissioning report, energy data collection measurement, optimizing energy performance, and maintaining indoor air quality.

Energy savings programs includes chiller plant control (adds and subtracts chillers to meet cooling loads).

## Building Automation and Chiller Plant Control

The UC800 controller can communicate with Trane Tracer Summit, and Tracer SC building automation systems, which include pre-engineered and flexible control for chiller plants.

These building automation systems can control the operation of the complete installation: chillers, pumps, isolating valves, air handlers, and terminal units. Trane can undertake full responsibility for optimized automation and energy management for the entire chiller plant. The main functions are:

- Chiller sequencing: equalizes the number of running hours of the chillers. Different control strategies are available depending on the configuration of the installation.
- Control of the auxiliaries: includes input/output modules to control the operation of the various auxiliary equipment (water pumps, valves, etc. )
- Time-of-day scheduling: allows the end user to define the occupancy period, for example: time of the day, holiday periods and exception schedules.
- Optimization of the installation start/stop time: based on the programmed schedule of occupancy and the historical temperature records. Tracer Summit and Tracer SC calculate the optimal start/stop time of the installation to get the best compromise between energy savings and comfort of the occupants.
- Soft loading: the soft loading function minimizes the number of chillers that are operated to satisfy a large chilled-water-loop pull down, thus preventing an overshoot of the actual capacity required. Unnecessary starts are avoided and the peak current demand is lowered.
- Communication capabilities: local, through a PC workstation keyboard. Tracer Summit and Tracer SC can be programmed to send messages to other local or remote workstations and or a pager in the following cases:
  - Analog parameter exceeding a programmed value
  - Maintenance warning
  - Component failure alarm
  - Critical alarm messages. In this latter case, the message is displayed until the operator acknowledges the receipt of the information. From the remote station it is also possible to access and modify the chiller plants control parameters.
- Remote communication through a modem: as an option, a modem can be connected to communicate the plant operation parameters through voice grade phone lines.

A remote terminal is a PC workstation equipped with a modem and software to display the remote plant parameters.

## Integrated Comfort System (ICS)

The on board Tracer chiller controller is designed to be able to communicate with a wide range of building automation systems. In order to take full advantage of chiller's capabilities, incorporate your chiller into a Tracer Summit or Tracer SC building automation system.

But the benefits do not stop at the chiller plant. At Trane, we realize that all the energy used in your cooling system is important. That is why we worked closely with other equipment manufacturers to predict the energy required by the entire system. We used this information to create patented control logic for optimizing HVAC system efficiency.

The building owners challenge is to tie components and applications expertise into a single reliable system that provides maximum comfort, control, and efficiency. Trane Integrated Comfort systems (ICS) are a concept that combines system components, controls, and engineering applications expertise into a single, logical, and efficient system. These advanced controls are fully commissioned and available on every piece of Trane® equipment, from the largest chiller to the smallest VAV box. As a manufacturer, only Trane offers this universe of equipment, controls, and factory installation and verification.

# Application Considerations

## Condenser Water Temperatures

Reduced sensitivity to condenser water startup temperatures is one major enhancement in the newest-generation water-cooled Series R chiller. With the model RTHD AFD chiller, a condenser water control method is necessary only if the unit starts with entering water temperatures below 55°F (12.8°C), or between 45°F (7.2°C) and 55°F (12.8°C), when a temperature increase of 1°F (0.56°C) per minute to 55°F (12.8°C) is not possible.

When the application requires startup temperatures below the prescribed minimums, a variety of options are available. To control a 2-way or 3-way valve, Trane offers a Condenser Regulating Valve Control option for the UC800 controls. This option enables the UC800 controls to send a signal for opening and closing the valve as necessary to maintain chiller differential pressure. The 2-way valves are available as a ship-with option. Tower bypass is also a valid control method if the chiller temperature requirements can be maintained.

Trane Series R chillers start and operate successfully and reliably over a range of load conditions with controlled entering condenser water temperature. Reducing the condenser water temperature is an effective method of lowering chiller power input required, but the ideal temperature for optimizing total system power consumption will depend on the overall system dynamics. From a system perspective, some improvements in chiller efficiency may be offset by the increased tower fan and pumping costs required to achieve the lower tower temperatures. Contact your local Trane systems solution provider for more information on optimizing system performance.

The minimum acceptable refrigerant pressure differential between condenser and evaporator is 23 psid. The chiller control system will attempt to obtain and maintain this differential at startup, but for continuous operation a design should maintain a 25°F (13.9°C) differential from evaporator leaving water temperature to condenser leaving water temperature.

## Variable Evaporator Flow and Short Evaporator Water Loops

Variable evaporator flow is an energysaving design strategy which has quickly gained acceptance as advances in chiller and controls technology have made it possible. With its linear unloading compressor design and advanced UC800 controls, the AdaptiR™ RTHD with AFD has excellent capability to maintain leaving water temperature control within  $\pm 0.5^\circ\text{F}$  (0.28°C), even for systems with variable evaporator flow and small chilled water volumes.

Some basic rules should be followed whenever using these system design and operational savings methods with the AdaptiR™ RTHD with AFD. The proper location of the chilled water temperature control sensor is in the supply (outlet) water. This location allows the building to act as a buffer, and it assures a slowly changing return water temperature. If there is insufficient water volume in the system to provide an adequate buffer, temperature control can be lost, resulting in erratic system operation and excessive compressor cycling. To ensure consistent operation and tight temperature control, the chilled water loop should be at least two minutes. If this recommendation cannot be followed, and tight leaving water temperature control is necessary, a storage tank or larger header pipe should be installed to increase the volume of water in the system.

For variable primary flow applications, the rate of chilled water flow change should not exceed 10 percent of design per minute to maintain  $\pm 0.5^\circ\text{F}$  (0.28°C) leaving evaporator temperature control. For applications in which system energy savings is most important and tight temperature control is classified as  $\pm 2^\circ\text{F}$  (1.1°C), up to 30 percent changes in flow per minute are possible. Flow rates should be maintained between the minimum and maximum allowed for any particular chiller configuration.

## Series Chiller Arrangements

Another energy-saving strategy is to design the system around chillers arranged in series, on the evaporator, condenser, or both. The actual savings possible with such strategies depends on the application dynamics and should be researched by consulting your Trane Systems Solutions Representative and applying the Trane System Analyzer program. It is possible to operate a pair of chillers more efficiently in a series chiller arrangement than in a parallel arrangement. It is also possible to achieve higher entering-to-leaving chiller differentials, which may, in turn, provide the opportunity for lower chilled water design temperature, lower design flow, and resulting installation and operational cost savings. The Trane screw compressor also has excellent capabilities for "lift", which affords an opportunity for savings on the evaporator and condenser water loops. Like series arrangements on the evaporator, series arrangements on the condenser may enable savings. This approach may allow reductions in pump and tower installation and operating costs.

Maximizing system efficiency requires that the designer balance performance considerations for all system components; the best approach may or may not involve multiple chillers, or series arrangement of the evaporators and/or condensers. This ideal balance of design integrity with installation and operating cost considerations can also be obtained by consulting a Trane representative and applying the Trane System Analyzer program.

## Water Treatment

The use of untreated or improperly treated water in chillers may result in scaling, erosion, corrosion, and algae or slime buildup. It is recommended that the services of a qualified water treatment specialist be engaged to determine what treatment, if any, is advisable. Trane assumes no responsibility for the results of using untreated or improperly treated water.

## Water Pumps

Where noise limitation and vibrationfree operation are important, Trane strongly encourages the use of 1750-rpm (60 Hz), 1450-rpm (50 Hz) pumps. Specifying or using 3600-rpm (60 Hz), 3000-rpm (50 Hz) condenser water and chilled water pumps must be avoided, because such pumps may operate with objectionable levels of noise and vibration. In addition, a low frequency beat may occur due to the slight difference in operating rpm between 3600-rpm (60 Hz), 3000-rpm (50 Hz) water pumps and Series R chiller motors. Important Note: The chilled water pump must not be used to stop the chiller.

## Acoustic Considerations

For chiller sound ratings, installation tips, and considerations on chiller location, pipe isolation, etc., refer to the Trane Water-Cooled Series R Chillers Sound Ratings and Installation Guide. Using the information provided in this bulletin, contact a certified sound consultant to aid in proper mechanical room design and treatment.



## Selection Procedure

Trane AdaptiR™ chiller performance is rated in accordance with the AHRI Standard 550/590-2011 Certification Program. Chiller selection assistance and performance information can be obtained by using the Series R chiller selection program, available through local Trane sales offices.

### Performance

The computerized AdaptiR™ chiller selection program provides performance data for each possible chiller selection at both full-load and part-load design points, as required.

It should be noted that changing the number of water passes or the water flow rates will generally alter the performance of a particular chiller. To attain maximum benefit from the wide range of chiller models and options available, designers are encouraged to first develop performance specifications and then use the chiller selection program to optimize all selections. This will help ensure selection of the compressor evaporator - condenser combination that most closely meets the job requirements. To optimize system performance, all selections should also be balanced with other system components.

### Fouling Factors

AHRI Standard 550 includes a definition of clean tube fouling. The recommended standard fouling adjustments are 0.0001 hr-sq ft-deg F/Btu (0.0176 sq m-deg C/kW) for the evaporator and 0.00025 hr-sq ft deg F/Btu (0.044 sq m-deg C/kW) for the condenser, from an increment of 0.0000 "clean." Chiller specifications should be developed using the most current standard fouling factors.

### Part Load Performance

Actual air-conditioning system loads are frequently less than full-load design conditions. Depending on the number of chillers on the job and the load profile, chillers may operate at full load a small percentage of the time. With their excellent part-load performance characteristics and highly energyefficient operation, AdaptiR™ chillers can provide significant operating savings at these part-load conditions, maximum down to 20%.

### System Considerations

Part-load chiller operation is frequently associated with reduced condenser water temperatures. However, rather than focusing only on the chiller, it is important to balance these temperatures to achieve the most efficient system operation possible. At part-load operation, the heat rejected to the cooling tower is less than at fullload operation.

Part-load chiller operation is also typically associated with reduced outside wet bulb temperatures, resulting in improved cooling tower performance. The net result of reduced heat rejection and lower wet bulb temperatures can be cooler condenser water entering the chiller, ultimately improving unit performance. However, this does not improve pump or tower efficiency. To achieve the most efficient system operation possible, it is best to minimize the total power draw of the chiller, tower, and pumps, which may not mean limiting the condenser water temperature to what the tower can provide. To determine specific unit and system part-load performance for chiller selection purposes, use the Series R chiller computer selection program or contact the local Trane sales office.



## Evaporator and Condenser Pressure Drop

Pressure drop data is determined by the AdaptiR™ chiller computer selection program available through local Trane sales offices.

## Dimensional Drawings

Dimensional drawings provided for selection purposes illustrate overall measurements of the unit. The recommended service clearances are those required to easily service the AdaptiR™ chiller. All catalog dimensional drawings are subject to change, and current submittal drawings should be referenced for more detailed dimensional information. Dimensional drawings are also available from the selection program. Contact the local Trane sales office for submittal information.

## Electrical Data Tables

Compressor motor electrical data is provided in the data section for each compressor size. Rated load amperes (RLA), locked rotor wye amperes (LRA) and expected inrush for AFD configurations are shown.

The RLA is based on the motor's performance when reaching full rated horsepower. The kW rating of the motor will equal or exceed the kW requirement indicated by the AdaptiR™ computer selection program at design conditions. If motor kW draw at design conditions is less than the kW rating of the motor, the RLA at design conditions is determined by multiplying the motor RLA (at the desired voltage) by this ratio: design kW/motor kW rating. This calculation is performed within the Series R chiller computer selection program, making RLA available as part of the design predictions. Predicted values include power factor variation from point to point.

A voltage utilization range is tabulated for each voltage listed. AdaptiR™ chillers are designed to operate satisfactorily over a utilization range of  $\pm 10$  percent of the standard design voltages: 380 V, 415 V for 50 Hertz, 380 V/60 Hz, 460 V/60 Hz, 3-phase.



# Model Number Description

**R T H D C B 1 R X A 0 X L B 1 A 3 L A L B 1 A 2 L A L**  
 1 2 3 4 5 6 7 8 9 10 11 12 13 14 15 16 17 18 19 20 21 22 23 24 25 26 27

### Digit 1-4 Basic Product Line

RTHD=Water-cooled AdaptiR™ Chillers

### Digit 5 Manufacturing Plant

U=Water Chiller Business Unit, Pueblo CO USA\*  
 E=Epinal Business Unit, Charmes\*  
 C=China Business Unit

### Digit 6-7 Compressor

B1=B1 compressor  
 B2=B2 compressor  
 C1=C1 compressor  
 C2=C2 compressor  
 D1=D1 compressor  
 D2=D2 compressor  
 D3=D3 compressor (50Hz only)  
 E3=E3 compressor (50Hz only)  
 D4=D4 compressor

### Digit 8 Unit Power Supply

A=200V/60Hz/3Ph power  
 C=230V/60Hz/3Ph power  
 D=380V/60Hz/3Ph power  
 R=380V/50Hz/3Ph power  
 T=400V/50Hz/3Ph power  
 U=415V/50Hz/3Ph power  
 F=460V/60Hz/3Ph power  
 H=575V/60Hz/3Ph power

### Digit 9 Design Specials

X=None  
 C=Specials denoted elsewhere  
 S=Specials not denoted elsewhere

### Digit 10-11 Design Sequence

E0=Factory/ABU assigned, start with A0(AFD Design)

### Digit 12 Agency Listing

X=No agency listing  
 U=C/UL listing  
 3=CCC-Chinese Compulsory Code

### Digit 13 Pressure Vessel Code

A=ASME pressure vessel code  
 C=Canadian code  
 L=Chinese code  
 S=Special

### Digit 14-15 Evaporator

B1=B1 evaporator  
 B2=B2 evaporator  
 C1=C1 evaporator  
 C2=C2 evaporator  
 D1=D1 evaporator  
 D2=D2 evaporator  
 D3=D3 evaporator  
 D4=D4 evaporator  
 D5=D5 evaporator  
 D6=D6 evaporator  
 E1=E1 evaporator  
 F1=F1 evaporator  
 F2=F2 evaporator  
 G1=G1 evaporator  
 G2=G2 evaporator  
 G3=G3 evaporator  
 H1=H1 evaporator  
 H2=H2 evaporator  
 H3=H3 evaporator

### Digit 16 Evap Tube type

A=Standard  
 B=High efficiency

### Digit 17 Evaporator Passes

2=2 pass evaporator  
 3=3 pass evaporator  
 4=4 pass evaporator

### Digit 18 Evaporator Water

Connection  
 L=Left hand evaporator connection  
 R=Right hand evaporator connection

### Digit 19 Evaporator Connection Type

B=Standard Grooved Pipe  
 C=Marine  
 D=Standard Flange Connection and companion  
 S=Special

### Digit 20 Evaporator Water Side

Pressure  
 L=150PSI/10.5Bar evaporator water pressure  
 H=300PSI/21Bar evaporator water pressure

### Digit 21-22 Condenser

B1=B1 condenser  
 B2=B2 condenser  
 D1=D1 condenser  
 D2=D2 condenser  
 E1=E1 condenser  
 E2=E2 condenser  
 E3=E3 condenser  
 E4=E4 condenser  
 E5=E5 condenser  
 F1=F1 condenser  
 F2=F2 condenser  
 F3=F3 condenser  
 G1=G1 condenser  
 G2=G2 condenser  
 G3=G3 condenser  
 G4=G4 condenser  
 G5=G5 condenser  
 G6=G6 condenser

### Digit 23 Condenser Tube Type

A=Enhanced fin-copper  
 B=Smooth bore-copper  
 C=Smooth bore-90/10 Cu/Ni

### Digit 24 Condenser Passes

2=2 pass

### Digit 25 Condenser Water Connection

L=Left hand evaporator connection  
 R=Right hand evaporator connection

### Digit 26 Condenser Connection Type

B=Standard Grooved Pipe  
 C=Marine  
 D=Standard Flange Connection and companion  
 S=Special

### Digit 27 Condenser Water Side Pressure

L=150PSI/10.5Bar evaporator water pressure  
 H=300PSI/21Bar evaporator water pressure

**A X X Q X C X A A D X D 1 7 4 A A X H X X X X X X X X X X**  
 28 29 30 31 32 33 34 35 36 37 38 39 40 41 42 43 44 45 46 47 48 49 50 51 52 53 54 55 56

**Digit 28 Condenser Leaving Water Temp**

A=Standard (<45 deg C)

**Digit 29 Refrigerant Specialties**

X=No refrigerant isolation valves  
 V=Refrigerant isolation valves

**Digit 30 Oil Cooler**

X=without oil cooler  
 C=with oil cooler

**Digit 31 Thermal Insulation**

X=No insulation  
 Q=Factory insulation cold parts  
 S=Thick insulation

**Digit 32 Sound Attenuator**

X=No attenuator  
 B=WRAP

**Digit 33 Control, Label and Literature Language**

E=English  
 C=Chinese

**Digit 34 Safety Devices**

X=Standard

**Digit 35 Shipping Charge**

A=Full factory charge  
 B=Nitrogen  
 C=Refrigerant charged less than 12kg(R134a)

**Digit 36 Shipping Package**

X=No Shipping Requirement  
 Z=Shipment Package + Unit Bottom Frame

**Digit 37 Flow Switch**

X=Without  
 A=Evap NEMA-1  
 B=Evap&Cond NEMA-1  
 C=Evap vapor  
 D= Evap&Cond Vapor

**Digit 38 Factory Performance Test**

X=Without  
 C=Witness test

D=Performance test w/report  
 S=Special

**Digit 39 Starter Type**

Y=Wye-delta closed transition starter\*  
 A=Solid state starter\*  
 D=AFD3 variable frequency starter  
 E=AFD4 variable frequency starter with filter

**Digit 40-42 Design RLA**

Selection RLA

**Digit 43 Power Line Connection Type**

A=Terminal block connection for incoming line  
 B=Mech disconnect switch  
 D=Circuit breaker  
 F=High interrupt circuit breaker  
 H=Ground fault circuit breaker  
 J= Ground fault high interrupt circuit breaker

**Digit 44 Enclosure Type**

A=NEMA1

**Digit 45 Under/over Voltage Protection**

X=No under/over voltage protection  
 U=under/over voltage protection

**Digit 46 Unit Operator Interface**

A=Dyna-view operator interface-Pueblo  
 D=Dyna-view/Spanish  
 G=Dyna-view/Trad. Chinese  
 H=Dyna-view/Simp. Chinese  
 J=Dyna-view/Japanese  
 K=Dyna-view/Portugese(Brazil)  
 L=Dyna-view/Korean  
 M=Dyna-view/Thai  
 T=TD7/Multiple. Language

**Digit 47 Remote Interfaces (digital comm)**

X=No remote digital comm  
 4=Tracer comm4 interface  
 5=Tracer comm4 interface  
 6=BACnet communication Interface  
 7=ModBus communication Interface

**Digit 48 External Chilled Water& Current Limit Setpoint**

X=None  
 4=4-20 ma input  
 2=2-10 V DC input

**Digit 49 External Base Loading**

X=None  
 4=4-20 ma input  
 2=2-10 V DC input

**Digit 50 Icemaking**

X=None  
 A=Icemaking with relay\*  
 B=Icemaking without relay\*

**Digit 51 Programmable Relays**

X=None  
 R=Programmable relay

**Digit 52 Chilled Water Reset-outdoor air temp**

X=No sensor (return water CHW reset standard)  
 T=Chilled water reset-outdoor air temp

**Digit 53 Reg. Valve&RLA**

X=None  
 V=Condenser reg. valve out &%RLA out  
 P=Condenser pressure (%HPC) &%RLA out  
 D=Chiller Delta P&% RLA out

**Digit 54 Refrigerant Monitor Input**

X=None  
 A=100 ppm/4-20 ma  
 B=1000 ppm/4-20 ma  
 C=100 ppm/2-10 V DC  
 D=1000 ppm/2-10 V DC

**Digit 55 Hot Water Control**

X=No

**Digit 56 Installation Accessories**

X=None  
 A=Elastomeric isolators



# General Data

## Nominal Data

Nominal Compressor	B1	B2	C1	C2	D1	D2	D3	D4	E3
Tonnage (50 Hz)	125-150	150-175	175-225	225-275	275-325	300-350	325-375	325-415	375-450
Tonnage (60 Hz)	175-200	200-225	225-275	275-325	325-400	375-450	N/A	325-415	N/A

### Notes:

1. Chiller selections can be optimized through the use of the AHRI-Certified Series R selection program and by contacting your local Trane sales office.

## General Data

Compressor Code	Evaporator Code	Condenser Code	Evaporator Water Storage		Condenser Water Storage		Refrigerant Type	Refrigerant Charge	
			Gallons	Liters	Gallons	Liters		lb	kg
B1	B1	B1	41	155	28	106	HFC-134a	410	186
B1	C1	D1	55	208	31	117	HFC-134a	490	222
B2	B2	B2	45	170	29	110	HFC-134a	410	186
B2	C2	D2	58	220	34	129	HFC-134a	490	222
C1	C2	D2	58	220	34	129	HFC-134a	490	222
C1	D3	E3	78	295	47	178	HFC-134a	490	222
C1	D6	E5	45	170	29	110	HFC-134a	490	222
C1	D5	E4	52	197	32	121	HFC-134a	490	222
C1	E1	F1	82	310	60	226	HFC-134a	525	238
C2	D4	E4	52	197	32	121	HFC-134a	490	222
C2	D3	E3	78	295	47	178	HFC-134a	490	222
C2	E1	F1	82	310	60	226	HFC-134a	525	238
C2	F2	F3	107	405	61	231	HFC-134a	624	283
D1	D1	E1	69	261	44	166	HFC-134a	474	215
D1	F1	F2	102	386	57	216	HFC-134a	624	283
D1	G1	G1	136	515	79	299	HFC-134a	701	318
D2	D2	E2	74	280	47	178	HFC-134a	474	215
D2	F2	F3	107	405	61	231	HFC-134a	624	283
D2	G2	G1	144	545	79	299	HFC-134a	701	318
D3/E3	D2	E2	74	280	47	178	HFC-134a	474	215
D3/E3	F2	F3	107	405	61	231	HFC-134a	624	283
D3/E3	G2	G1	144	545	79	299	HFC-134a	701	318
D3/E3	G3	G3	157	596	118	446	HFC-134a	701	318
D4	H1	G4	136	516	101	383	HFC-134a	882	400
D4	H2	G5	146	552	123	467	HFC-134a	882	400
D4	H3	G6	171	646	155	585	HFC-134a	882	400
E3	H3	G3	171	646	118	446	HFC-134a	882	400

Minimum/Maximum Evaporator Flow Rates (Gallons/Minute )

Evaporator Code	Two Pass			Three Pass			Four Pass		
	Min	Max	Nominal Conn Size (In. )	Min	Max	Nominal Conn Size (In. )	Min	Max	Nominal Conn Size (In. )
B1	253	1104	8	168	736	6	-	-	-
B2	288	1266	8	192	844	6	-	-	-
C1	320	1412	8	213	941	6	-	-	-
C2	347	1531	8	232	1022	6	-	-	-
D1	415	1812	8	275	1205	8	208	906	6
D2	450	1980	8	300	1320	8	225	990	6
D3	486	2131	8	324	1417	8	242	1065	6
D4	351	1542	8	234	1028	8	176	771	6
D5	351	1542	8	234	1028	8	176	771	6
D6	293	1287	8	196	860	8	147	644	6
E1	450	1980	8	300	1320	8	225	989	6
F1	563	2478	10	376	1655	8	-	-	-
F2	604	2667	10	404	1780	8	-	-	-
G1	-	-	-	505	2218	10	379	1666	8
G2	-	-	-	550	2413	10	411	1807	8
G3	-	-	-	621	2732	10	466	2050	8
H1	-	-	-	427	1564	10	320	1173	8
H2	-	-	-	481	1763	10	361	1323	8
H3	-	-	-	596	2186	10	447	1640	8

Notes:

1. Minimum flow rates are based on water only.
2. All water connections are flange connections.



## General Data

### Minimum/Maximum Evaporator Flow Rates (Liters/Second)

Evaporator Code	Two Pass			Three Pass			Four Pass		
	Min	Max	Nominal Conn Size (mm)	Min	Max	Nominal Conn Size (mm)	Min	Max	Nominal Conn Size (mm)
B1	16	70	200	11	46	150	-	-	-
B2	18	80	200	12	53	150	-	-	-
C1	20	89	200	13	59	150	-	-	-
C2	22	97	200	15	65	150	14	57	150
D1	26	114	200	17	76	200	15	62	150
D2	28	125	200	19	83	200	-	-	-
D3	31	134	200	20	89	200	12	48	150
D4	22	97	200	15	65	200	12	48	150
D5	22	97	200	15	65	200	10	40	150
D6	18	81	200	12	54	200	-	-	-
E1	28	125	200	19	83	200	14	62	150
F1	36	156	250	24	104	200	-	-	-
F2	38	168	250	25	112	200	-	-	-
G1	-	-	-	32	140	250	24	105	200
G2	-	-	-	36	152	250	26	114	200
G3	-	-	-	39	172	250	29	129	200
H1	-	-	-	27	99	250	20	74	200
H2	-	-	-	30	111	250	23	83	200
H3	-	-	-	38	138	250	28	103	200

**Notes:**

1. Minimum flow rates are based on water only.
2. All water connections are flange connections.

### Minimum/Maximum Condenser Flow Rates (Gallons/Minute)

Condenser Code	Two Pass		
	Min	Max	Nominal Conn Size (In. )
B1	193	850	6
B2	212	935	6
D1	193	850	6
D2	212	935	6
E1	291	1280	8
E2	316	1390	8
E3	325	1420	8
E4	245	1080	8
E5	206	910	8
F1	375	1650	8
F2	355	1560	8
F3	385	1700	8
G1	444	1960	8
G2	535	2360	8
G3	589	2599	8
G4	423	1552	8
G5	551	2021	8
G6	730	2677	8

**Notes:**

1. Minimum flow rates are based on water only.
2. All water connections are flange connections.

### Minimum/Maximum Condenser Flow Rates (Liters/Second)

Condenser Code	Two Pass		
	Min	Max	Nominal Conn Size (mm)
B1	12	54	150
B2	13	59	150
D1	12	54	150
D2	13	59	150
E1	18	81	200
E2	20	88	200
E3	21	90	200
E4	15	68	200
E5	13	57	200
F1	24	104	200
F2	22	98	200
F3	24	107	200
G1	28	124	200
G2	34	149	200
G3	37	164	200
G4	27	98	200
G5	35	128	200
G6	46	169	200

**Notes:**

1. Minimum flow rates are based on water only.
2. All water connections are flange connections.

# Electrical Data and Connections

## Compressor Motor Electrical Data (50 Hertz)

Compressor Code	Nominal Voltage	380	400	415
		Voltage	342/	374/
	Utilization Range	418	457	457
B1, B2	Max kW	139	148	148
	RLA @ Max kW	233	233	233
	LRAY	391	428	428
	LRAD	1229	1348	1348
C1, C2	Max kW	201	213	216
	RLA @ Max kW	349	349	349
	LRAY	456	498	498
	LRAD	1414	1544	1544
D1, D2, D3	Max kW	271	284	284
	RLA @ Max kW	455	455	455
	LRAY	711	776	776
	LRAD	2303	2515	2515
E3	Max kW	288	306	306
	RLA @ Max kW	488	488	488
	LRAY	711	776	776
	LRAD	2303	2515	2515

### Notes:

1. See Selection Procedure Section for details.
2. The RLA @ Max kW is based on the performance of the motor developing full rated horsepower.
3. Electrical component sizing should be based on actual jobsite operating conditions. This factor can be obtained through the use of the Series R chiller selection program available through local Trane sales offices.

## Compressor Motor Electrical Data (60 Hertz)

Compressor Code	Nominal Voltage	200	230	380	460	575
		Voltage	180/	208/	342/	414/
	Utilization Range	220	254	418	506	633
B1, B2	Max kW	174	174	174	174	174
	RLA @ Max kW	557	484	291	241	798
	LRAY	970	818	488	400	329
	LRAD	3103	2617	1561	1280	1053
C1, C2	Max kW	249	249	249	249	249
	RLA @ Max kW	812	698	421	349	279
	LRAY	1173	936	558	469	375
	LRAD	3634	2901	1727	1453	1162
D1, D2	Max kW	329	329	329	329	329
	RLA @ Max kW	888	888	549	455	367
	LRAY	1690	1532	850	730	612
	LRAD	5477	4966	2755	2366	1984
D4 (VVi)	Max kW			445		
	RLA @ Max kW			750		
	LRAY			850		
	LRAD			2755		

### Notes:

1. See Selection Procedure Section for details.
2. The RLA @ Max kW is based on the performance of the motor developing full rated horsepower.
3. Electrical component sizing should be based on actual jobsite operating conditions. This factor can be obtained through the use of the Series R chiller selection program available through local Trane sales offices.

# Electrical Data and Connections - RTHD AFD normal models

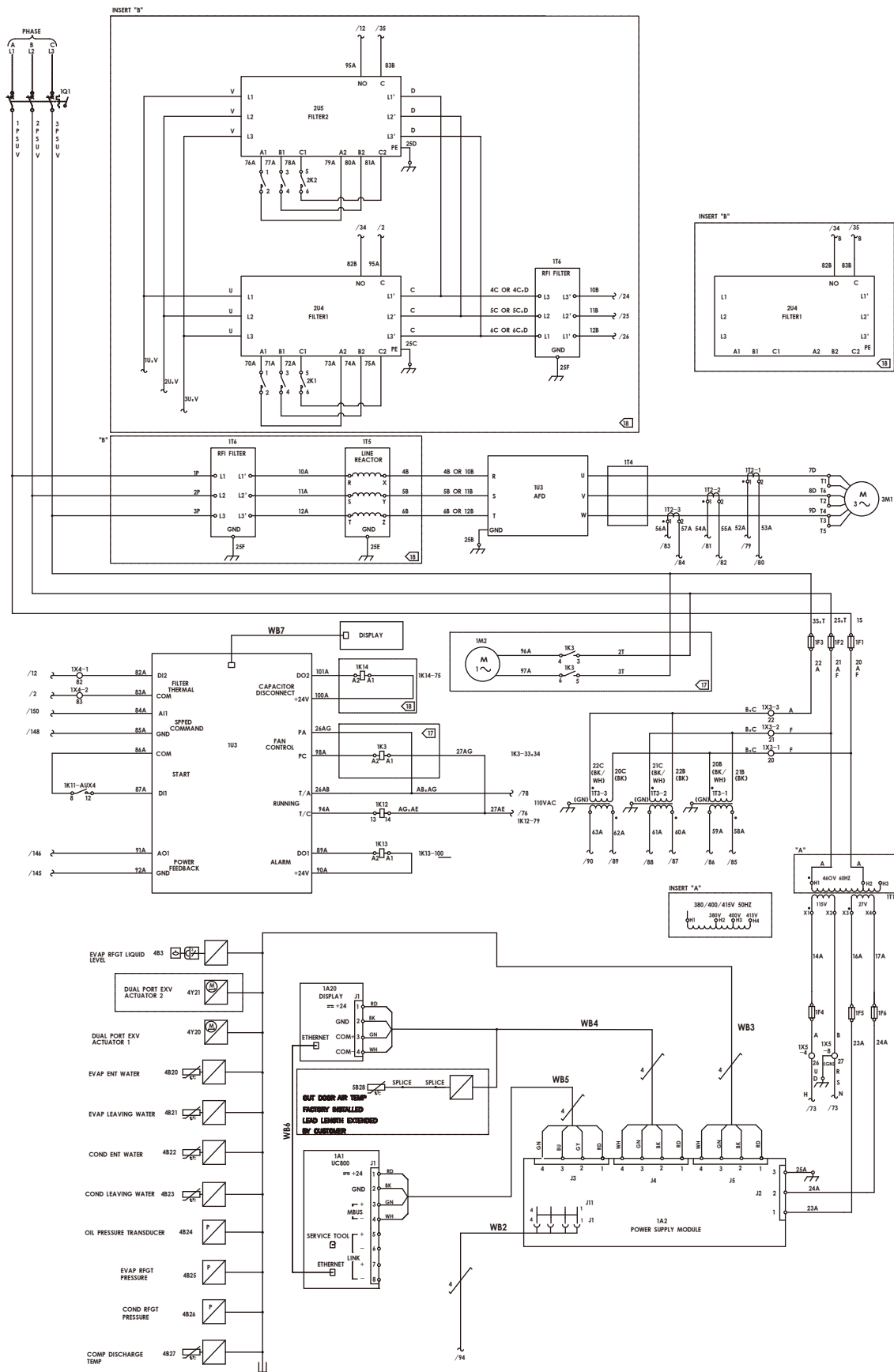



# Electrical Data and Connections - RTHD AFD normal models

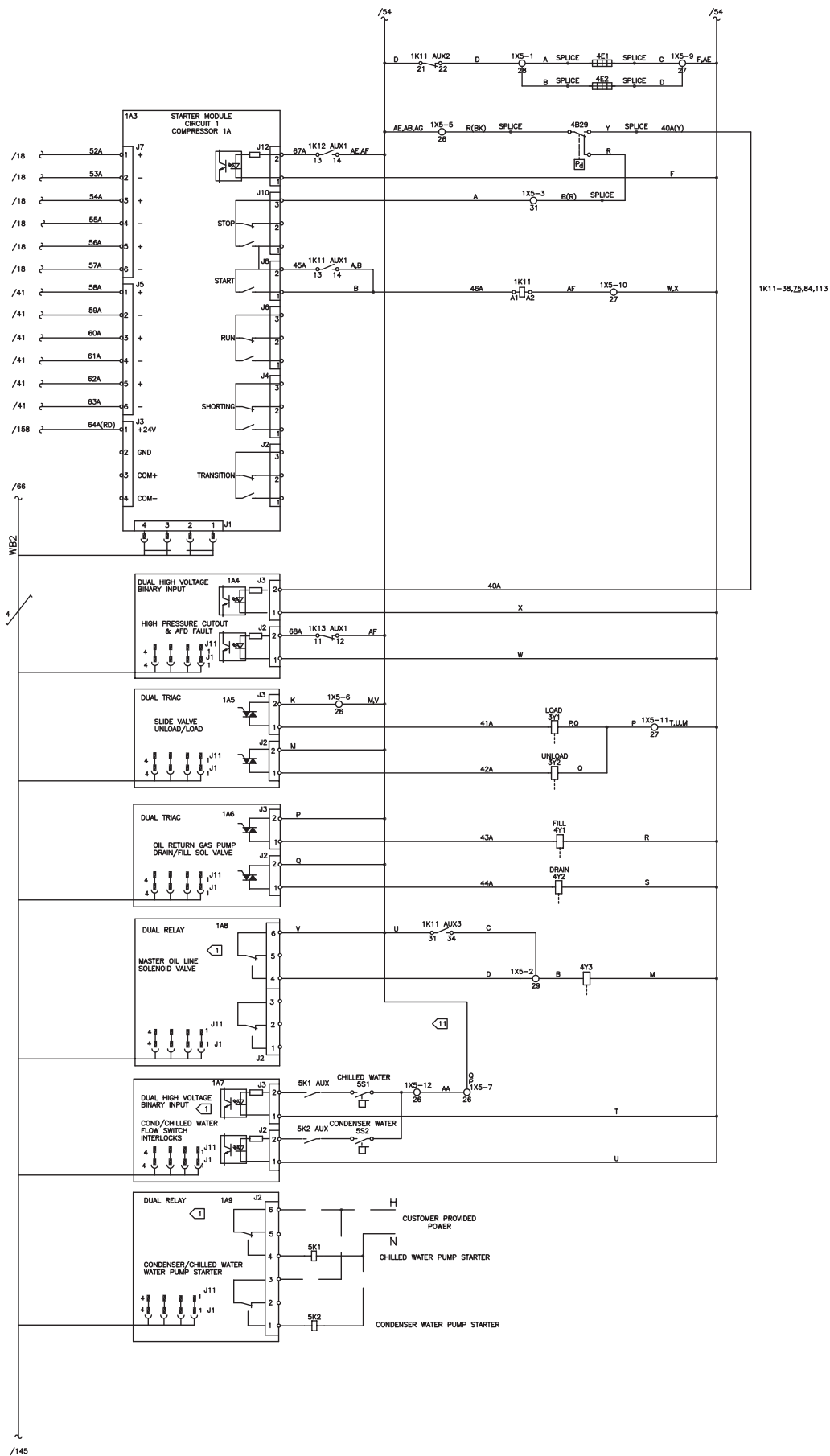

# Electrical Data and Connections - RTHD AFD normal models

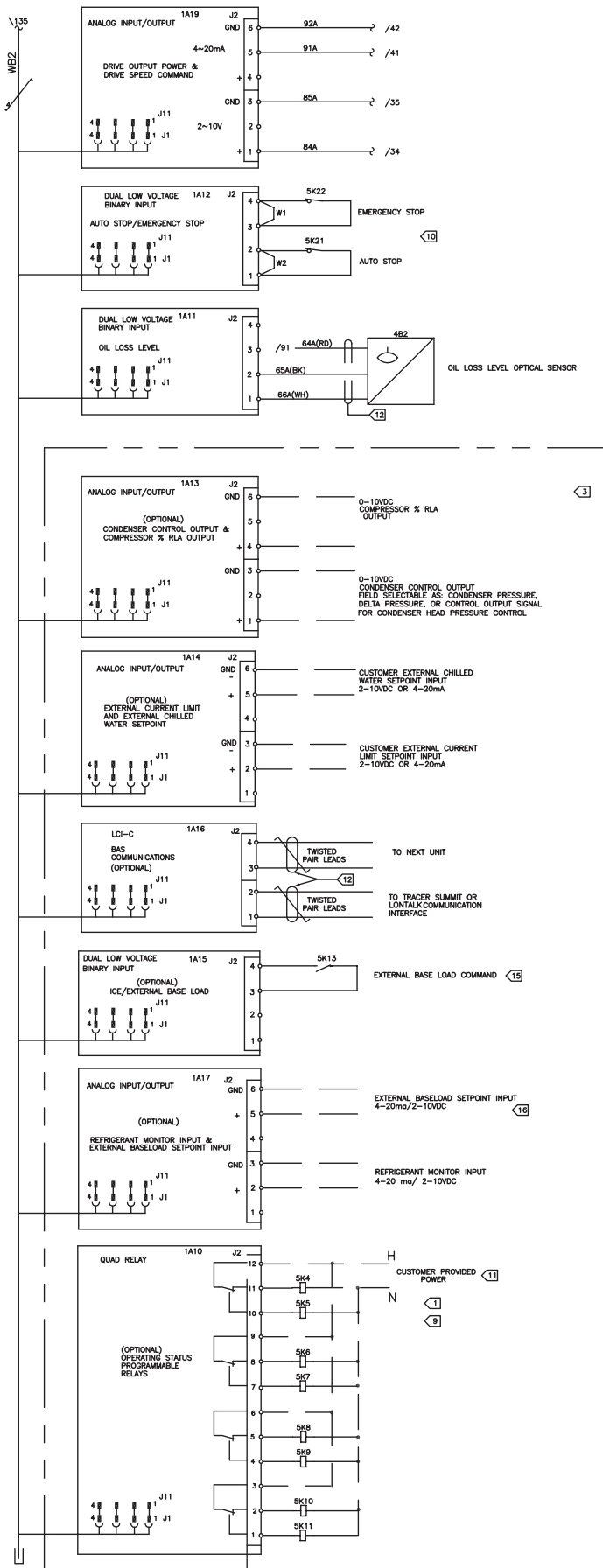

## Electrical Data and Connections - RTHD AFD normal models

COLOR CODE	
BK	BLACK
BN	BROWN
BU	BLUE
GY	GRAY
RD	RED
WH	WHITE
GN	GREEN
OG	ORANGE
YE	YELLOW

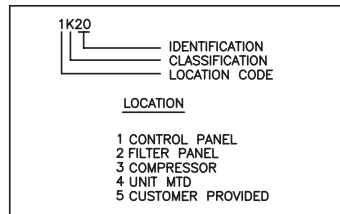

—————	TRANE WIRING
—————	CUSTOMER WIRING
-----	OPTIONS

LINE #	ITEM	DESCRIPTION
56	1A1	UCBOO CONTROLLER
58	1A2	POWER SUPPLY MODULE
78	1A3	STARTER MODULE
98	1A4	SOLID STATE STARTER FAULT AND HIGH PRESSURE CUTOFF SWITCH
103	1A5	SLIDE VALVE UNLOAD AND LOAD CONTROL SOLENOID VALVE
108	1A6	OIL RETURN GAS PUMP DRAIN AND FILL SOLENOID VALVE
120	1A7	CONDENSER AND CHILLED WATER FLOW SWITCH INTERLOCKS
113	1A8	ICE BUILDING STATUS OUTPUT AND MASTER OIL LINE SOLENOID VALVE
125	1A9	CONDENSER AND CHILLED WATER PUMP STARTER
195	1A10	OPERATING STATUS PROGRAMMABLE RELAYS
157	1A11	OIL LOSS LEVEL SENSOR AND UNUSED INPUTS
152	1A12	EXTERNAL AUTO/STOP AND EMERGENCY STOP INPUT
164	1A13	CONDENSER CONTROL AND % RLA OUTPUT
171	1A14	EXTERNAL CURRENT LIMIT AND CHILLED WATER
183	1A15	ICE BUILDING CONTROL AND EXTERNAL BASE LOADING COMMAND
178	1A16	LCI-C (COMM 5)
188	1A17	REFRIGERANT MONITOR INPUT AND EXTERNAL BASE LOADING SETPOINT
146	1A19	DRIVE OUTPUT POWER INPUT AND DRIVE SPEED COMMAND OUTPUT
48	1A20	TD 7 DISPLAY
5	1Q1	MAIN CIRCUIT BREAKER
30	1F1, 1F2, 1F3	PRIMARY FUSES – CPT, UOVM
49	1F4	SECONDARY FUSE 115V
49	1F5, 1F6	SECONDARY FUSES 27V
36	1K3	FAN CONTACTOR
85	1K11	START CONTROL RELAY
39	1K12	RUNNING STATUS CONTROL RELAY
41	1K13	ALARM STATUS CONTROL RELAY
22	1M2	AFD FAN MOTOR
43	1T1	TRANSFORMER
14,15,16	1T2-1,2,3	CURRENT TRANSFORMERS
39	1T3-1,2,3	UNDER OVER VOLTAGE TRANSFORMERS
15	1T4	COMMON MODE CHOKE
15	1T5	LINE REACTOR
15	1T6	RFI FILTER
15	1U3	AFD
34,35,36	1X3	UNDER OVER VOLTAGE TERMINAL BLOCK
	1X5	CONTROL TERMINAL BLOCK 115V
104	3Y1	LOAD SOLENOID VALVE
106	3Y2	UNLOAD SOLENOID VALVE
15	3M1	COMPRESSOR MOTOR
75,76	4E1-2	OIL SUMP HEATERS
109	4Y1	FILL SOLENOID VALVE
111	4Y2	DRAIN SOLENOID VALVE
115	4Y3	MASTER OIL LINE SOLENOID
158	4B2	OIL LOSS LEVEL SWITCH
46	4B3	EVAPORATOR REFRIGERANT LIQUID LEVEL SENSOR
52	4B20	EVAPORATOR ENTERING WATER TEMP. SENSOR
54	4B21	EVAPORATOR LEAVING WATER TEMP. SENSOR
56	4B22	CONDENSER ENTERING WATER TEMP. SENSOR
58	4B23	CONDENSER LEAVING WATER TEMP. SENSOR
60	4B24	OIL PRESSURE TRANSDUCER
62	4B25	EVAPORATOR REFRIGERANT PRESSURE TRANSDUCER
64	4B26	CONDENSER REFRIGERANT PRESSURE TRANSDUCER
66	4B27	COMPRESSOR DISCHARGE TEMP. SENSOR
78	4B29	HIGH PRESSURE CUTOFF SWITCH
48,50	4Y20-21	DUAL PORT EXV ACTUATOR
53	5B28	OUTDOOR AIR TEMP. SENSOR
127	5K1	CHILLED WATER PUMP STARTER
130	5K2	CONDENSER WATER PUMP STARTER
196-206	5K4-11	UNIT STATUS RELAYS
183	5K13	EXTERNAL BASE LOAD ENABLE
152	5K22	EXTERNAL EMERGENCY STOP
154	5K21	EXTERNAL AUTO STOP
120	5S1	CHILLED WATER FLOW SWITCH
122	5S2	CONDENSER WATER FLOW SWITCH

# Electrical Data and Connections - RTHD VVi models

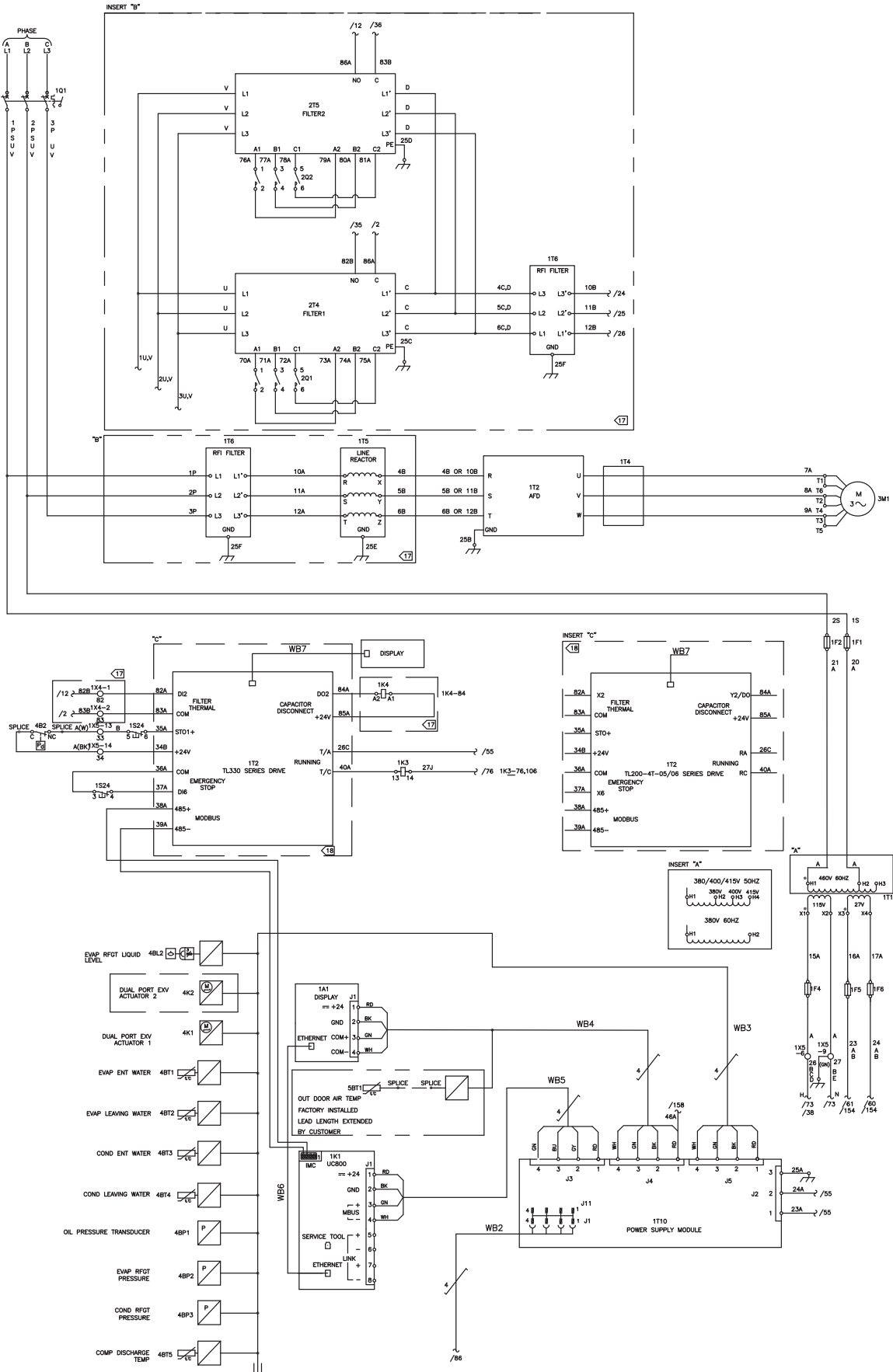

# Electrical Data and Connections - RTHD VVi models

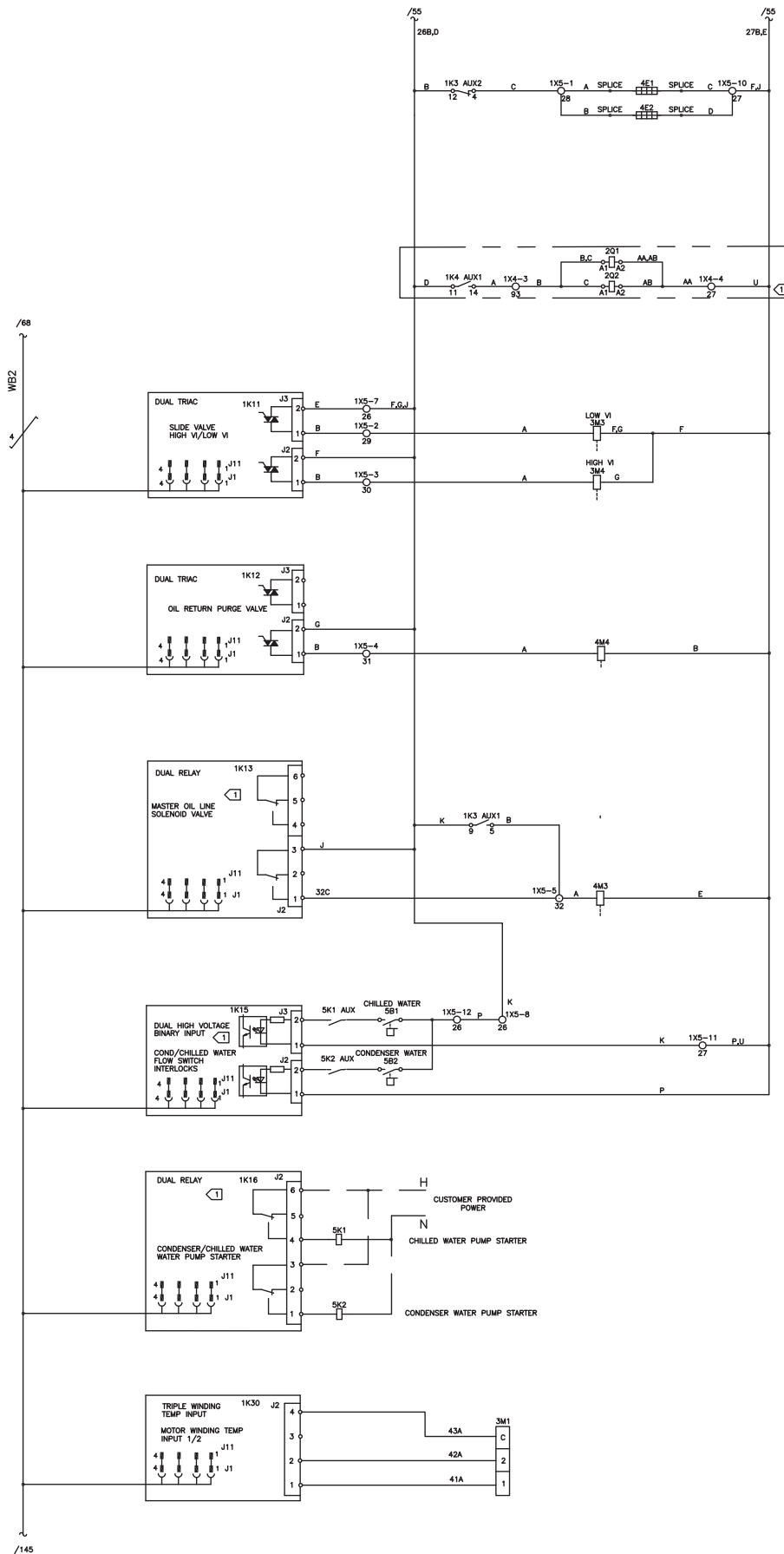



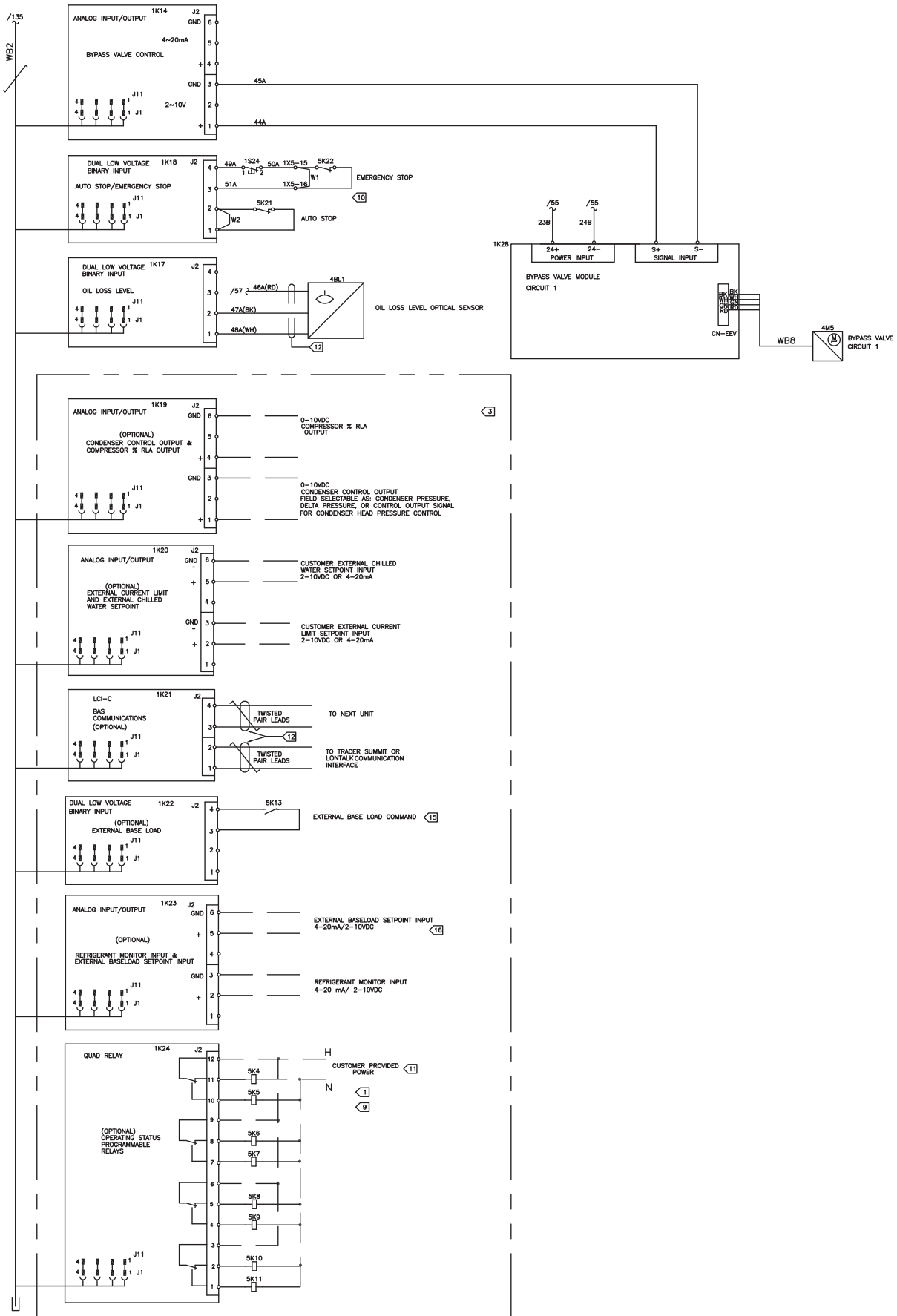

# Electrical Data and Connections - RTHD VVi models

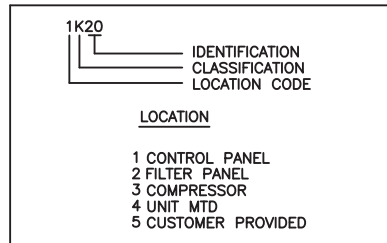

## Electrical Data and Connections - RTHD VVi models

COLOR CODE	
BK	BLACK
BN	BROWN
BU	BLUE
GY	GRAY
RD	RED
WH	WHITE
GN	GREEN
O	ORANGE
Y	YELLOW



	TRANE WIRING
	CUSTOMER WIRING
	OPTIONS

LINE #	ITEM	DESCRIPTION
50	1A1	TD 7 DISPLAY
32	1F1, 1F2	PRIMARY FUSES - CPT
51	1F4	SECONDARY FUSE 115V
51	1F5, 1F6	SECONDARY FUSES 27V
58	1K1	UC800 CONTROLLER
39	1K3	RUNNING STATUS CONTROL RELAY
35	1K4	AUXILIARY RELAY
90	1K11	HIGH VI AND LOW VI CONTROL SOLENOID VALVE
97	1K12	OIL RETURN PURGE SOLENOID VALVE AND UNUSED
106	1K13	MASTER OIL LINE SOLENOID VALVE AND UNUSED
146	1K14	BYPASS VALVE OUTPUT AND UNUSED
115	1K15	CONDENSER AND CHILLED WATER FLOW SWITCH INTERLOCKS
123	1K16	CONDENSER AND CHILLED WATER PUMP STARTER
157	1K17	OIL LOSS LEVEL SENSOR AND UNUSED
152	1K18	EXTERNAL AUTO/STOP AND EMERGENCY STOP INPUT
164	1K19	CONDENSER CONTROL AND % RLA OUTPUT
171	1K20	EXTERNAL CURRENT LIMIT AND CHILLED WATER
183	1K22	ICE BUILDING CONTROL AND EXTERNAL BASE LOADING COMMAND
178	1K21	LCI-C (COMM 5)
188	1K23	REFRIGERANT MONITOR INPUT AND EXTERNAL BASE LOADING SETPOINT
199	1K24	OPERATING STATUS PROGRAMMABLE RELAYS
158	1K28	BYPASS VALVE MODULE
131	1K30	MOTOR WINDING TEMP INPUT 1 AND 2
5	1Q1	MAIN CIRCUIT BREAKER
37,40,152	1S24	EMERGENCY STOP
45	1T1	TRANSFORMER
25,38	1T2	AFD
25	1T4	COMMON MODE CHOKE
25	1T5	LINE REACTOR
16,25	1T6	RFI FILTER
59	1T10	POWER SUPPLY MODULE
	1X5	CONTROL TERMINAL BLOCK 115V
19	2Q1	CAPACITOR DISCONNECT CONTACTOR 1#
9	2Q2	CAPACITOR DISCONNECT CONTACTOR 2#
16	2T4	PHF FILTER 1#
6	2T5	PHF FILTER 2#
25/132	3M1	COMPRESSOR MOTOR
90	3M3	LOW VI SOLENOID VALVE
92	3M4	HIGH VI SOLENOID VALVE
158	4BL1	OIL LOSS LEVEL SWITCH
48	4BL2	EVAPORATOR REFRIGERANT LIQUID LEVEL SENSOR
54	4BT1	EVAPORATOR ENTERING WATER TEMP. SENSOR
56	4BT2	EVAPORATOR LEAVING WATER TEMP. SENSOR
58	4BT3	CONDENSER ENTERING WATER TEMP. SENSOR
60	4BT4	CONDENSER LEAVING WATER TEMP. SENSOR
62	4BP1	OIL PRESSURE TRANSDUCER
64	4BP2	EVAPORATOR REFRIGERANT PRESSURE TRANSDUCER
66	4BP3	CONDENSER REFRIGERANT PRESSURE TRANSDUCER
68	4BT5	COMPRESSOR DISCHARGE TEMP. SENSOR
37	4B2	HIGH PRESSURE CUTOFF SWITCH
76,77	4E1,2	OIL SUMP HEATERS
52,50	4K1,2	DUAL PORT EXV ACTUATOR
109	4M3	MASTER OIL LINE SOLENOID
99	4M4	OIL RETURN PURGE SOLENOID VALVE
161	4M5	BYPASS VALVE
55	5BT1	OUTDOOR AIR TEMP. SENSOR
114	5B1	CHILLED WATER FLOW SWITCH
116	5B2	CONDENSER WATER FLOW SWITCH
123	5K1	CHILLED WATER PUMP STARTER
126	5K2	CONDENSER WATER PUMP STARTER
196-206	5K4-11	UNIT STATUS RELAYS
183	5K13	EXTERNAL BASE LOAD ENABLE
154	5K21	EXTERNAL AUTO STOP
152	5K22	EXTERNAL EMERGENCY STOP

# Dimensions

150psig(1.0MPa)

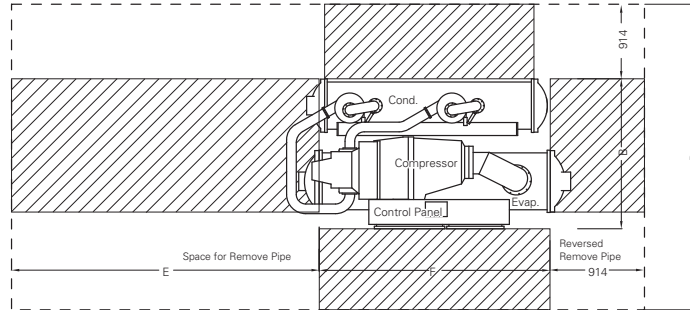

Space Layout

2(or 4) pass in Evap.

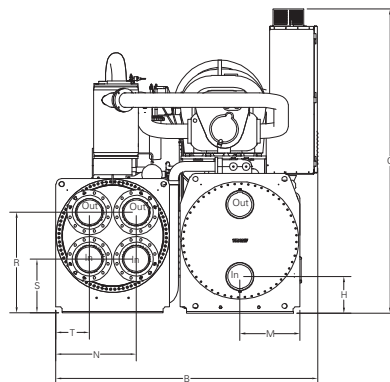
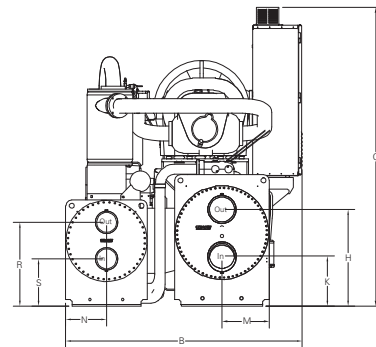
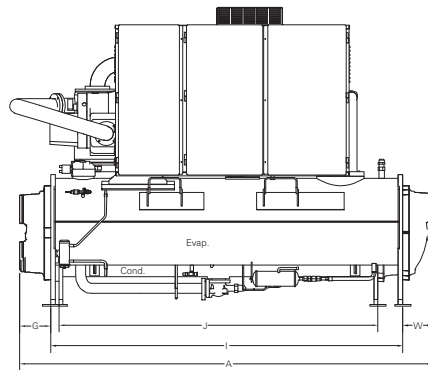

Total Heat Recovery

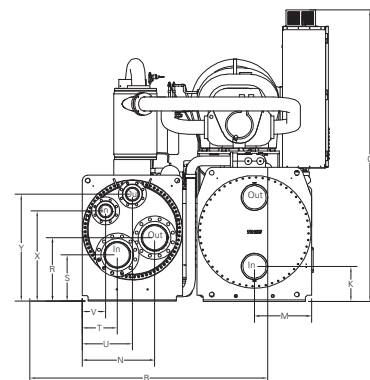

Partial Heat Recovery



150psig(1.0MPa)

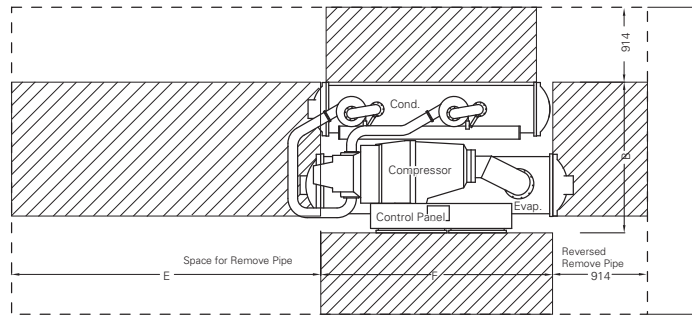

Space Layout

3 pass in Evap.

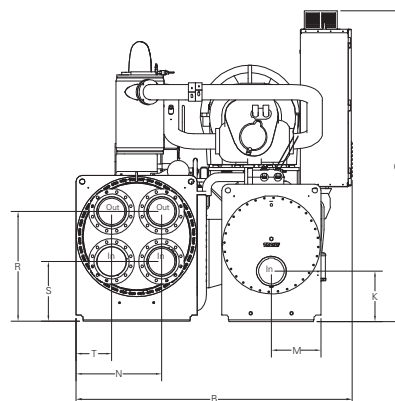
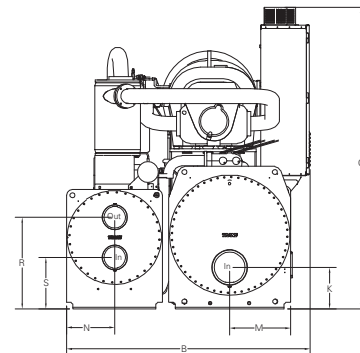
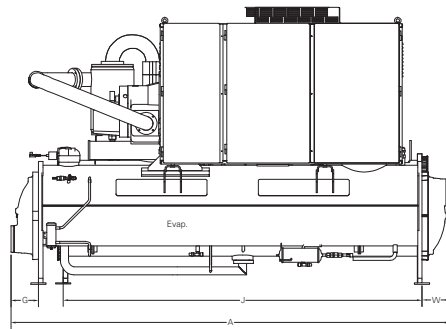

Total Heat Recovery

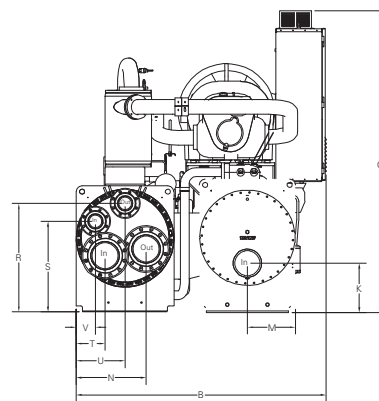

Partial Heat Recovery

# Dimensions Sheet

Model	Evap. Pass	mm															
		A	B	C	D	E	F	G	H	I	J	K	M	N	R	S	W
B1B1B1V	3	3414	1785	2253	3475	2743	2730	340	726	2734	2477	351	580	292	622	349	340
B1C1D1V	3	3878	1785	2253	3475	3200	3194	340	726	3198	2977	351	580	292	622	349	340
B2B2B2V	3	3414	1785	2253	3475	2743	2730	340	726	2734	2477	351	580	292	622	349	340
B2C2D2V	3	3878	1785	2253	3475	3200	3194	340	726	3198	2977	351	580	292	622	349	340
C1C2D2V	3	3878	1850	2253	3536	3200	3194	340	726	3198	2977	351	641	292	622	349	340
C1D6E5V	3	3534	1867	2320	3557	2743	2730	400	765	2734	2977	378	503	318	692	358	400
C1D5E4V	3	3534	1867	2320	3557	2743	2730	400	765	2734	2477	378	503	318	692	358	400
C1D3E3V	4	3534	1867	2320	3557	2743	2730	285	793	2734	2477	349	503	318	692	358	181
C1E1F1V	3	3998	1867	2320	3557	3200	3194	400	765	3198	2477	378	503	318	692	358	400
C2D4E4V	3	3534	1867	2320	3557	2743	2730	400	765	2734	2997	378	503	318	692	358	400
C2D3E3V	3	3534	1867	2320	3557	2743	2730	400	765	2734	2477	378	503	318	692	358	400
C2E1F1V	4	3534	1867	2320	3557	3200	3194	285	793	3198	2477	349	503	318	692	358	181
C2F2F3V	3	3958	1867	2320	3557	3200	3194	380	722	3198	2997	290	503	318	692	358	380
D1D1E1V	3	3534	1867	2320	3557	2743	2730	400	765	2734	2477	378	503	318	692	358	400
D1F1F2V	3	3958	1867	2320	3557	3200	3194	380	722	3198	2997	290	503	318	692	358	380
D1G1G1V	4	4012	1922	2418	3615	3302	3289	390	861	3198	3297	289	503	373	739	405	235
D2D2E2V	3	3534	1867	2320	3557	2743	2730	400	765	2734	2477	378	503	318	692	358	400
D2F2F3V	3	3958	1867	2320	3557	3200	3194	380	722	3198	2997	290	503	318	692	358	380
D2G2G1V	4	4012	1922	2418	3615	3302	3289	390	861	3198	3297	289	503	373	739	405	235
D3D2E2V	3	3534	1867	2320	3557	2743	2730	260	765	2734	2477	378	503	318	692	358	260
D3F2F3V	3	3958	1867	2320	3557	3200	3194	380	722	3198	2997	290	503	318	692	358	380
D3G2G1V	4	4012	1922	2418	3615	3302	3289	390	861	3198	3297	289	503	373	739	405	235
D3G3G3V	4	4012	1895	2418	3615	3302	3289	390	861	3198	3297	289	503	373	739	405	235
E3F2F3V	3	3958	1867	2320	3557	3200	3194	380	722	3198	2997	290	503	318	692	358	380
E3G2G1V	4	4012	1922	2418	3615	3302	3289	390	861	3198	3297	289	503	373	739	405	235
E3G3G3V	4	4012	1922	2419	3615	3302	3289	390	861	3198	3297	289	503	373	739	405	235
E3H3G3V	3	4133	1922	2175	3615	3302	3289	396	830	3198	3289	310	473	373	701	401	393
D4H1G4V	3	4130	1898	2043	3615	3302	3289	393	830	3194	3289	310	473	373	701	401	393
D4H2G5V	3	4130	1898	2043	3615	3302	3289	393	830	3194	3289	310	473	373	701	401	393
D4H3G6V	3	4130	1898	2043	3615	3302	3289	393	830	3194	3289	310	473	373	701	401	393
D4H1G4V	4	4133	1898	2043	3615	3302	3289	396	860	3194	3289	282	473	373	701	401	246
D4H2G5V	4	4133	1898	2043	3615	3302	3289	396	860	3194	3289	282	473	373	701	401	246
D4H3G6V	4	4133	1898	2043	3615	3302	3289	396	860	3194	3289	282	473	373	701	401	246

Model	Evap. Pass	mm																				
		A	B	C	D	E	F	G	H	I	J	K	M	N	R	S	W	T	U	V	X	Y
B1C1H1V	3	3674	1981	2253	3670	3200	3194	240	726	3198	2997	351	580	572	668	362	240	258	/	/	/	/
B2C2H2V	3	3674	1981	2253	3670	3200	3194	240	726	3198	2997	351	580	572	668	362	240	258	/	/	/	/
C1E1J1V	3	3712	2105	2320	3793	3200	3194	260	765	3198	2997	378	503	635	815	445	261	265	/	/	/	/
C2F2J3V	3	3736	2108	2322	3793	3200	3194	272	722	3198	2997	290	503	635	815	445	272	265	/	/	/	/
D1F1J2V	3	3736	2108	2322	3793	3200	3194	272	722	3198	2997	290	503	635	815	445	272	265	/	/	/	/
D2G2K1V	4	3774	2111	2418	3800	3302	3289	310	861	3198	3297	289	503	635	796	426	235	265	/	/	/	/
D3G2K1V	4	3774	2111	2418	3800	3302	3289	310	861	3198	3297	289	503	635	796	426	235	265	/	/	/	/
E3G2K1V	4	3774	2111	2418	3800	3302	3289	310	861	3198	3297	289	503	635	796	426	235	265	/	/	/	/
B1C1L1V	3	3674	1852	2253	3541	3200	3194	240	726	3198	2997	351	580	447	384	354	240	183	318	152	569	672
B2C2L2V	3	3674	1852	2253	3541	3200	3194	240	726	3198	2997	351	580	447	384	354	240	183	318	152	569	672
C1E1M1V	3	3712	1966	2320	3654	3200	3194	260	765	3198	2997	378	503	537	531	431	261	223	375	164	750	850
C2F2M3V	3	3736	1976	2322	3654	3200	3194	272	722	3198	2997	290	503	537	531	431	272	223	375	164	750	850
D1F1M2V	3	3736	1976	2322	3654	3200	3194	272	722	3198	2997	290	503	537	531	431	272	223	375	164	750	850
D2G2N1V	4	3774	2076	2418	3765	3302	3289	310	861	3198	3297	289	503	652	598	352	235	390	415	245	798	896
D3G2N1V	4	3774	2076	2418	3765	3302	3289	310	861	3198	3297	289	503	652	598	352	235	390	415	245	798	896
E3G2N1V	4	3774	2076	2418	3765	3302	3289	310	861	3198	3297	289	503	652	598	352	235	390	415	245	798	896

# Mechanical Specifications

## General

Exposed metal surfaces are painted with air-dry beige, direct-to-metal, single-component paint. Each unit ships with full operating charges of refrigerant and oil. Molded neoprene isolation pads are supplied for placement under all support points. Startup and operator instruction by factory-trained service personnel are included.

## Adaptive Frequency™ Drive (AFD)

Trane Adaptive Frequency™ Drive (AFD)- customized version of AFD series -Trane TL380, is an air cooled and unit mounted drive and be integrated in the starter panel. It has 2 frames, 13 models, which could be applied 380V/400V/415V in 50Hz and 380V/60Hz, 460V/60Hz. It is integrated AC line reactor minimize line harmonics to less than 40% total harmonic distortion (THDi). Optional low harmonic filter provides the harmonic solution to meet the requirement of IEEE 519 with input of AFD, reducing harmonic distortion to less than 5% THD.

Trane Communicated Drive- RTHD VVi series- Trane TL330, is an air cooled and unit mounted drive and integrated in the starter panel. It has 2 frames, 7 models, which could be applied on 380V/400V/415V at 50Hz and 380V/60Hz, 460V/60Hz. It is integrated with AC line reactor to minimize line harmonics to less than 40% total harmonic distortion (THDi). Harmonic filter option provides low harmonic solution to meet the requirement of IEEE 519 with input of AFD, reducing harmonic distortion to less than 5% THD.

## Compressor and Motor

The unit is equipped with a semihermetic, direct-drive, 1500-3600rpm (3000rpm @ 50 Hz) rotary compressor that includes a capacity control slide valve, oil sump heater, and differential pressure refrigerant oil flow system. Four pressure-lubricated, rolling element bearing groups support the rotating assembly. The motor is a suction gas-cooled, hermetically sealed, two-pole, squirrel cage induction-type.

## Evaporator and Condenser

Shells are carbon steel plate. The evaporator and condenser are designed, tested, and stamped in accordance with ASME Code for refrigerant-side/ working-side pressure of 200 psig.

All tube sheets are made of carbon steel; tubes are mechanically expanded into tube sheets and mechanically fastened to tube supports. Evaporator tubes are 1.0-inch (25.4 mm) diameter and condenser tubes are 0.75-inch (19.05 mm) diameter. Both types can be individually replaced. Standard tubes are externally finned, internally enhanced seamless copper with lands at all tube sheets.

All water pass arrangements are available with flange connections (150 or 300 psig waterside). All connections may be either right- or left-handed. Waterside shall be hydrostatically tested at 1.5X design working pressure.

## Refrigerant Circuit

An electronically controlled expansion valve is provided to maintain proper refrigerant flow.

## Unit Controls (UC800)

The microprocessor-based control panel is factory-installed and factory tested. The control system is powered by a control power transformer, and will load and unload the chiller through AFD modulation of compressor speed and in combination with slide valve at low load. Microprocessor-based chilled water reset based on return water is standard.

The UC800 microprocessor automatically acts to prevent unit shutdown due to abnormal operating conditions associated with low evaporator refrigerant temperature, high condensing temperature, and/or motor current overload. If an abnormal operating condition continues and the protective limit is reached, the machine should shut down.

The panel includes machine protection shutdown requiring manual reset for the following

conditions:

- low evaporator refrigerant temperature and pressure
- high condenser refrigerant pressure
- low oil flow
- critical sensor or detection circuit faults
- motor current overload
- high compressor discharge temperature
- lost communication between modules
- electrical distribution faults: phase loss, phase imbalance, or phase reversal
- external and local emergency stop
- starter transition failure

The panel also includes machine protection shutdown with automatic reset for the following correctable conditions:

- momentary power loss
- under/over voltage
- loss of evaporator or condenser water flow
- high motor winding temperature
- comm loss: adaptive frequency drive
- excessive condenser pressure

When a fault is detected, the control system conducts more than 100 diagnostic checks and displays results. The display will identify the fault, indicate date, time, and operating mode at time of occurrence, and provide type of reset required and a help message. The diagnostic history will display the last ten diagnostics with their times and dates of occurrence.

## Clear Language Display Panel

Factory-mounted to the control panel door, the operator interface has an LCD touch-screen display for operator input and information output. This interface provides access to the following information: evaporator report, condenser report, compressor report, ASHRAE Guideline 3 report, operator settings, service settings, service tests, and diagnostics. All diagnostics and messages are displayed in "clear language."

Data contained in available reports includes:

- Water and air temperatures
- Refrigerant levels and temperatures
- Oil pressure
- Flow switch status
- EXV position
- Head pressure control command
- Compressor starts and run-time
- Line phase percent RLA, amps, and volts
- Motor winding temperatures
- Compressor Vi state command

All necessary settings and setpoints are programmed into the microprocessorbased controller via the operator interface. The controller is capable of receiving signals contemporaneously from a variety of control sources, in any combination, and priority order of control sources can be programmed.

The control source with priority determines active setpoints via the signal it sends to the control panel.

Control sources may be:

- the local operator interface (standard)
- a hard-wired 4-20 mA or 2-10 V DC signal from an external source (interface optional; control source not supplied)
- Generic BAS (optional points; control source not supplied)
- LonTalk LCI-C (interface optional; control source not supplied)
- Trane Tracer Summit™ system (interface optional)

Trane - by Trane Technologies (NYSE:TT), a global climate innovator - creates comfortable, energy efficient indoor environments for commercial and residential applications. For more information, please visit [trane.com](http://trane.com) or [tranetechnologies.com](http://tranetechnologies.com).

Trane has a policy of continuous product and product data improvement and reserves the right to change design and specifications without notice. We are committed to using environmentally conscious print practices.

RTHD-PRC004G-EN August 2021  
Supersedes RTHD-PRC004F-EN (June 2020)

©2021 Trane