



Trane – by Trane Technologies (NYSE: TT), a global climate innovator – creates comfortable, energy efficient indoor environments through a broad portfolio of heating, ventilating and air conditioning systems and controls, services, parts and supply. For more information, please visit [trane.com](http://trane.com) or [tranetechnologies.com](http://tranetechnologies.com).

UN-SLB007-EN 25 Oct 2023  
Supersedes

©2023 Trane. All rights reserved.

# CGAU

## Air-cooled Modular Chiller





# CGAU New Series

Air-cooled Modular Chiller



## Efficient and energy saving

High efficiency models, help reduce energy consumption and CO<sub>2</sub> emission.



## Stable and reliable

Comprehensive protection programs, and high-quality components ensure the long-term reliable operation of the unit.



## Intelligent control

The 7-inch color touch screen brings humanized operation experience, more function and more convenient.



## Flexible and adaptable

Flexible investment, convenient installation and transportation, easy maintenance.

# Trane Introduction



Trane is a leading global provider of indoor comfort systems and comprehensive facility solutions, with branches in over 100 countries, 29 production bases with a total of 29,000 employees worldwide. Since its establishment in 1913, Trane has always been committed to providing customers with efficient and energy-saving heating, ventilation and refrigeration air-conditioning systems, services and spare parts services, as well as advanced building automation solutions.

Trane has long been in the leading position in the world in terms of design, research and development capability and technological progressiveness of water chillers, and has more than 10 years of successful experience in the modular machine market. With the continuous iteration and innovation of products, the current modular machine product line is very rich, which can meet the vast majority of building needs and is widely used in industries, public buildings, offices, supermarkets, hotels, residential and other fields.



### Efficient and Energy Saving

#### Double circuit design

The 130kW modular chiller has a double circuit design. Refrigerant system and air side heat exchanger in each circuit can be operating independently, when under partial load, one circuit can be closed while the other side continues to operate, thereby reducing energy consumption.

#### High efficiency plate heat exchanger

A stainless steel plate heat exchanger designed with optimized refrigeration and heating has high heat exchange efficiency. Another advantage of the optimized design is that the water pressure drop is very low, which can effectively reduce the power consumption of the water pump.



#### High efficiency fin-tube heat exchanger design

The design structure of U-shaped fin-tube coils maximizes the air exchange area design with multi-angle air intake, increase the heat exchange area effectively and improve the heat exchange effect significantly.

The left and right sides are designed with independent air ducts, and each duct can operate independently with a fan and compressor.

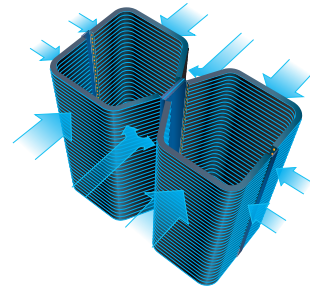

#### Electronic expansion valve precise control

Adopting a 480 step high-precision electronic expansion valve, the electronic expansion valve has been accurately and logically set for different working conditions, ensuring that the unit is always in the optimal operating state.

On the other hand, the electronic expansion valve responds quickly and sensitively, with more precise control, and there is no static overheating or control lag phenomenon of the thermal expansion valve.

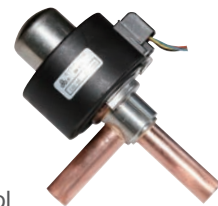

#### High efficiency fan design

A large air volume and low noise axial flow fan designed with aerodynamic optimization, and a high static pressure fan with a maximum air supply 80Pa can be selected, achieving efficient air supply on various installation sites. Some models use variable frequency fans or dual speed fans to intelligently unload the fan speed according to different loads, effectively reducing energy consumption for some loads. Another benefit of reducing wind speed is that it can reduce fan noise, making it quieter and more comfortable.

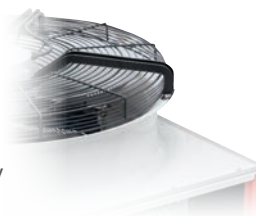

### Stable and Reliable

#### Emergency backup operation can be realized in case of failure

- Some models that adopt a dual circuit design, such as the CXAU130, can continue to operate in the event of a single circuit failure, maximizing the non shutdown of the other circuit.
- When a group of modular chiller is under centralized control, if one of the modular chiller need maintenance, the remaining units can still operate continuously.

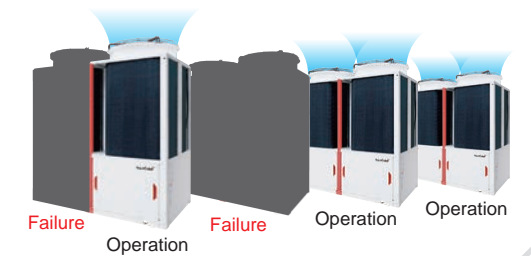

#### Balanced operation of compressor

Monitoring of the operating time of each modular chiller and compressor in the system, intelligent adjustment of the operating time of each modular chiller compressor, balanced of the operating time of the unit and compressor, effectively extending the life cycle of the unit and reducing the maintenance frequency.



#### Reliable components

- Standard four-sided sheet metal protection: Each modular chiller manufactured by Trane with a four-sided sheet metal panel, which is not only beautiful and elegant, but also can protect important parts from direct exposure, greatly reducing the invasion of wind, rain, dust and even small animals.
- Standard water filter: CGAU065 adopts a patented drum water filter designed by Trane, which is more convenient to disassemble and clean compared to ordinary Y-shaped filters and has stronger pollution capacity. The CGAU130 uses stainless steel water filter which have a larger capacity for contamination. The stainless-steel water filter are more corrosion-resistant.
- Differential pressure water flow switch: The unit is equipped with a standard built-in differential pressure water flow switch, providing precise flow protection for the unit. Customers do not need to configure it.



#### Multiple protection

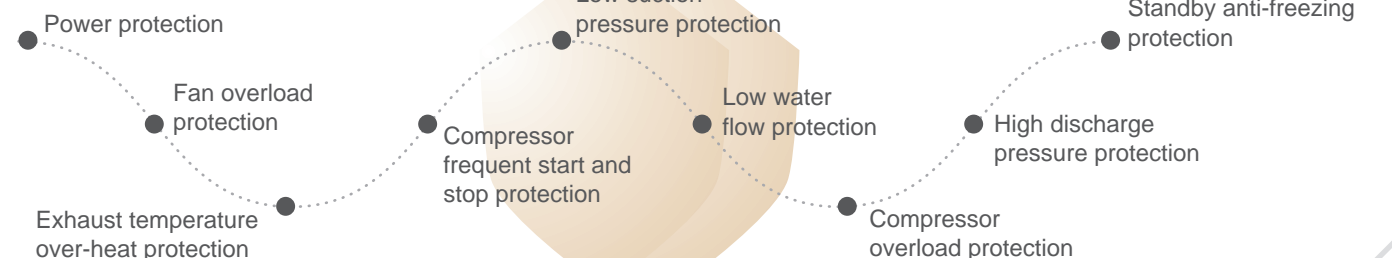



### Intelligent Control

#### Full Function - Convenient Operation



Schedule Management



Self-diagnosis



- CGAU uses a new 7-inch color touch screen, the interface is clear and easy to operate.
- The schedule management mode can set the unit to automatically turn on/off by week or day.
- Self-restart function after power recovery. Customers can choose to activate this function by their needs, In case of accidental power off failure, the system will automatically record the operating mode before power off and restore the original mode after power restoration.
- Remote control mode can remotely switch on/off the unit and switch cooling and heating mode through the host contact.
- Perfect self-diagnosis function, clear view of fault query to help maintenance quickly solve problems.
- All-day noise reduction mode or night noise reduction mode can be selected. The fan speed can be intelligently adjusted to create a comfortable and quiet environment.

#### Intelligent Communication - System Centralized Control

- 7-inch color touch screen centralized controller supports up to 16 module units to meet the needs of centralized management of most projects.

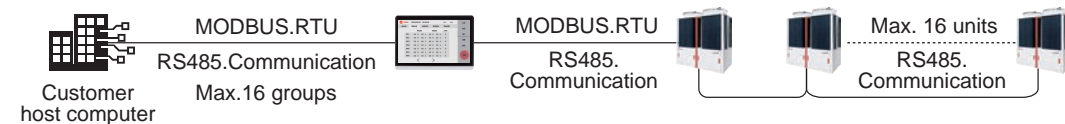

- With RS485 interface, standard open MODBUS protocol, easy access to building management system (BMS).
- When the host computer system is centrally controlled, it supports control of up to 16 groups with up to 256 units.

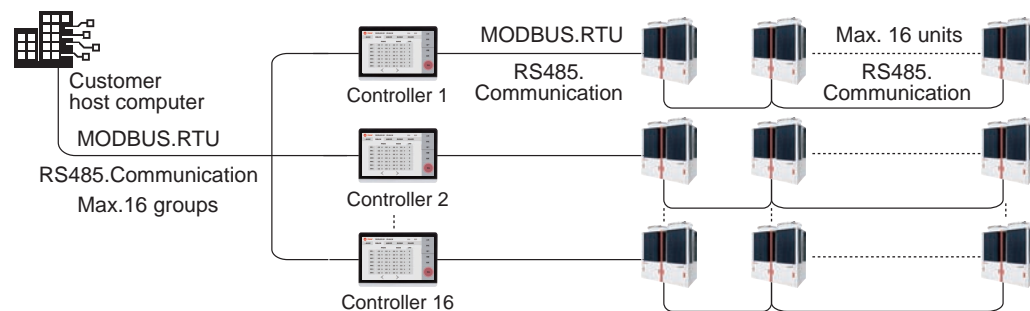

### CGAU Standard Model

#### Smart and adaptable

- **Smart investment:** Modular design, capable of gradually increasing equipment according to project stages, with strong and convenient expansion capacity.
- **Smart transportation:** Single modular chiller has small size and light weight, and the unit can be lifted and transported by forklift. Transportation vehicles can be large or small, without relying on large equipment.
- **Smart installation:** The installation site can be flexibly selected, including roofs, open spaces and platforms. At the same time, there is no need for cooling towers, cooling water pumps or dedicated machine rooms.
- **Smart Maintenance:** When some modular chiller fail, the other units can still work normally, and customers can flexibly arrange maintenance time. At the same time, the standardization of components makes maintenance faster and more efficient.

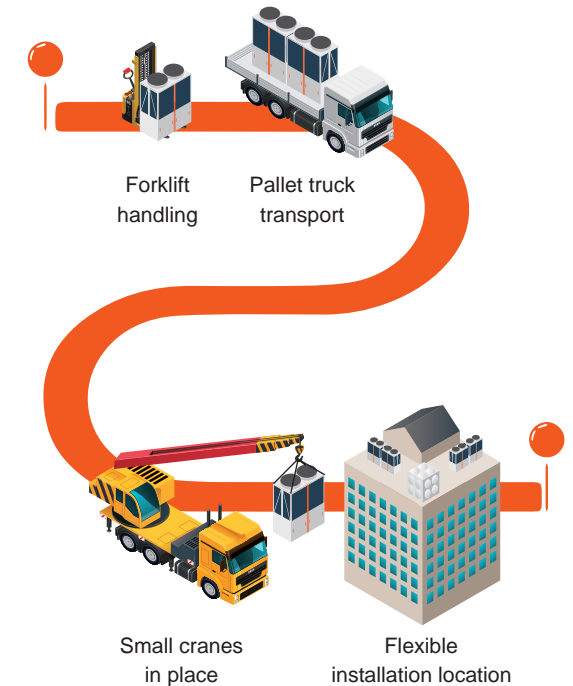

#### Low carbon and environmental protection

CGAU module uses chlorine-free environmentally friendly refrigerant R410A, which is non-toxic, does not damage the ozone layer and protects the environment.

#### Unique appearance

- The 65 modules have a compact structure and a height of only 1690mm, leading the industry.
- The iconic of Trane Red is bright and eye-catching, with high recognition.
- Mold opening design with red handles for easy panel disassembly.
- Obtaining appearance patent certificate.



# CGAU New Series

## Air-cooled Modular Chiller

### Parameters Table

Model		CGAU065	CGAU130	
Cooling	Nominal Cooling Capacity	kW	66	136
	Input Power	kW	21.5	42.8
	Operating Current	A	40.5	85.0
Maximum Operation	Maximum Power	kW	36	63
	Maximum Current	A	68	107
Refrigerant	Type	-	R410A	
	Number of Refrigerant Circuits	-	1	2
	Charge Quantity	kg	11.2	10×2
Compressor	Type	-	Hermetic Scroll Compressor	
	Quantity	↑	1	2
Water Side	Type of Heat Exchanger	-	High Efficiency Plate Heat Exchanger	
	Rated Water Flow	m <sup>3</sup> /h	11.4	22.4
	Pressure Drop	kPa	39	41
	Pressure Drop(with standard filter)	kPa	51	46
	Water Pipe Connection	inch	Rc 2	Rc 2-1/2
Air Side	Fan Type	-	Variable Frequency Fan	Axial Flow Fan
	Fan Quantity	no.	2	2
	Fan Volume	m <sup>3</sup> /h	12500×2	23500×2
	Fan Power	kW	0.75×2	1.8×2
	Type of Heat Exchanger	-	High Efficiency Fin Heat Exchanger	
Unit	COP	kW/kW	3.07	3.18
	IPLV	kW/kW		
	Power Supply	V/PH/Hz	380~415/3N~/50	
	Net Weight	kg	300	860
	Operating Weight	kg	305	870
Dimensions	Width	mm	1790	2200
	Depth	mm	840	1150
	Height	mm	1690	2390

Remarks:  
 • The cooling capacity is 7°C water outlet /12°C water inlet, air inlet at 35°C of ambient temperature.  
 • The design and executive standard of the unit is AHRI standard 551/591.  
 • Due to system optimization reasons of the product, change of the data will be conducted without notice.

### Dimensions and Installation

CGAU065

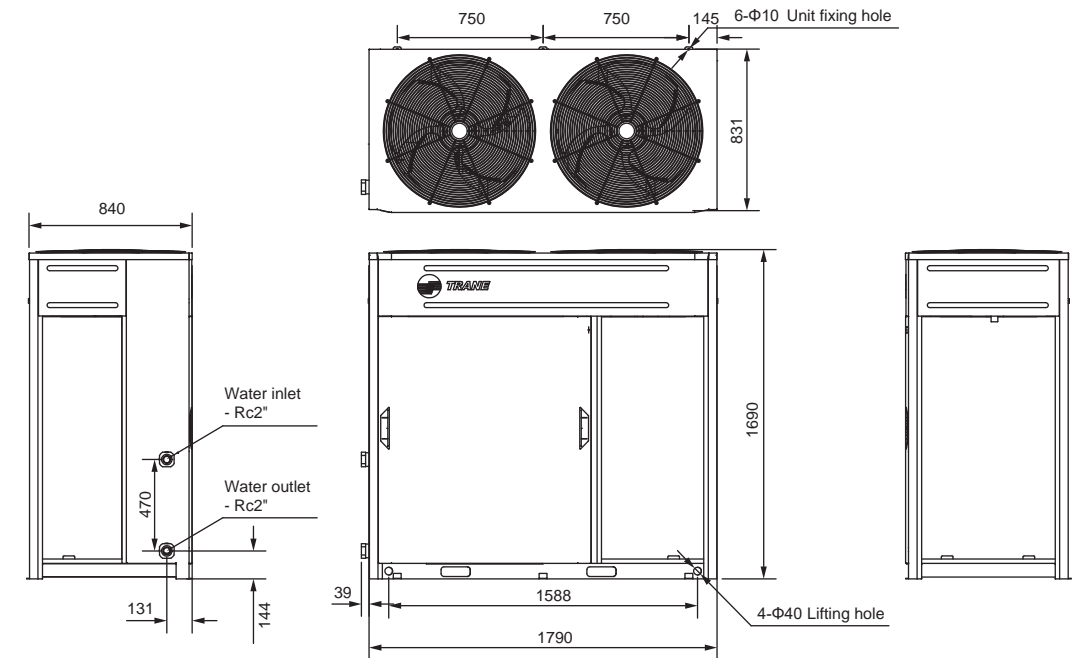

CGAU130

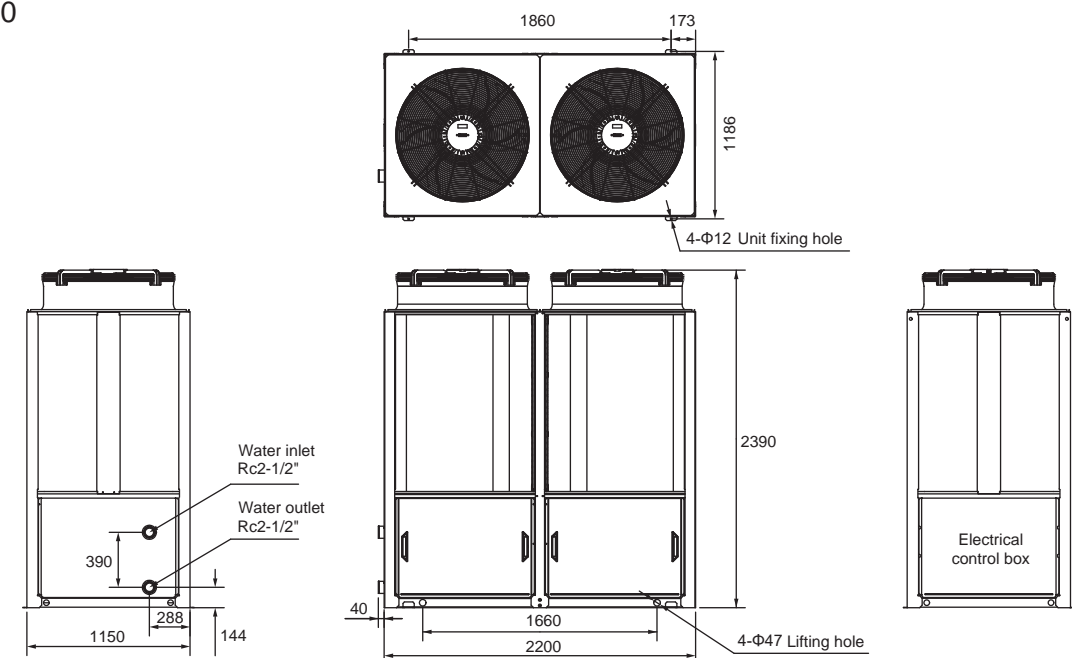

# CGAU New Series

## Air-cooled Modular Chiller

### Water System

Installation diagram of fixed water flow air conditioning application water system

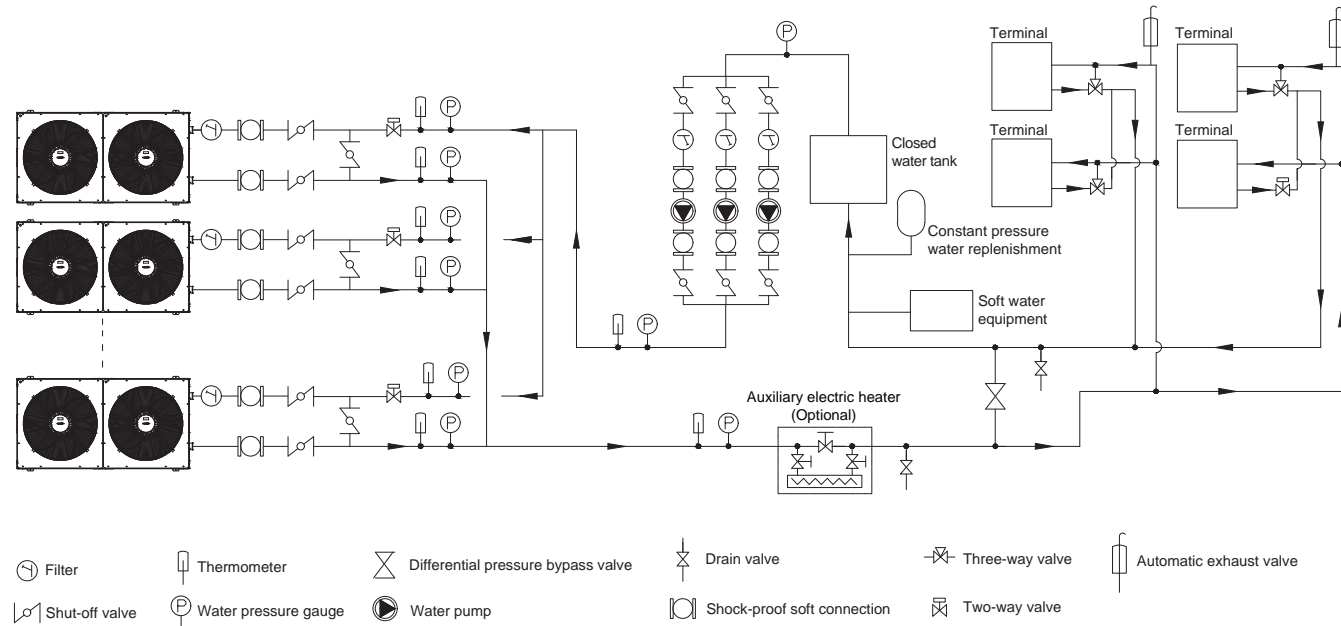

### Installation Space Requirements

Schematic diagram of Installation space requirements for a single unit

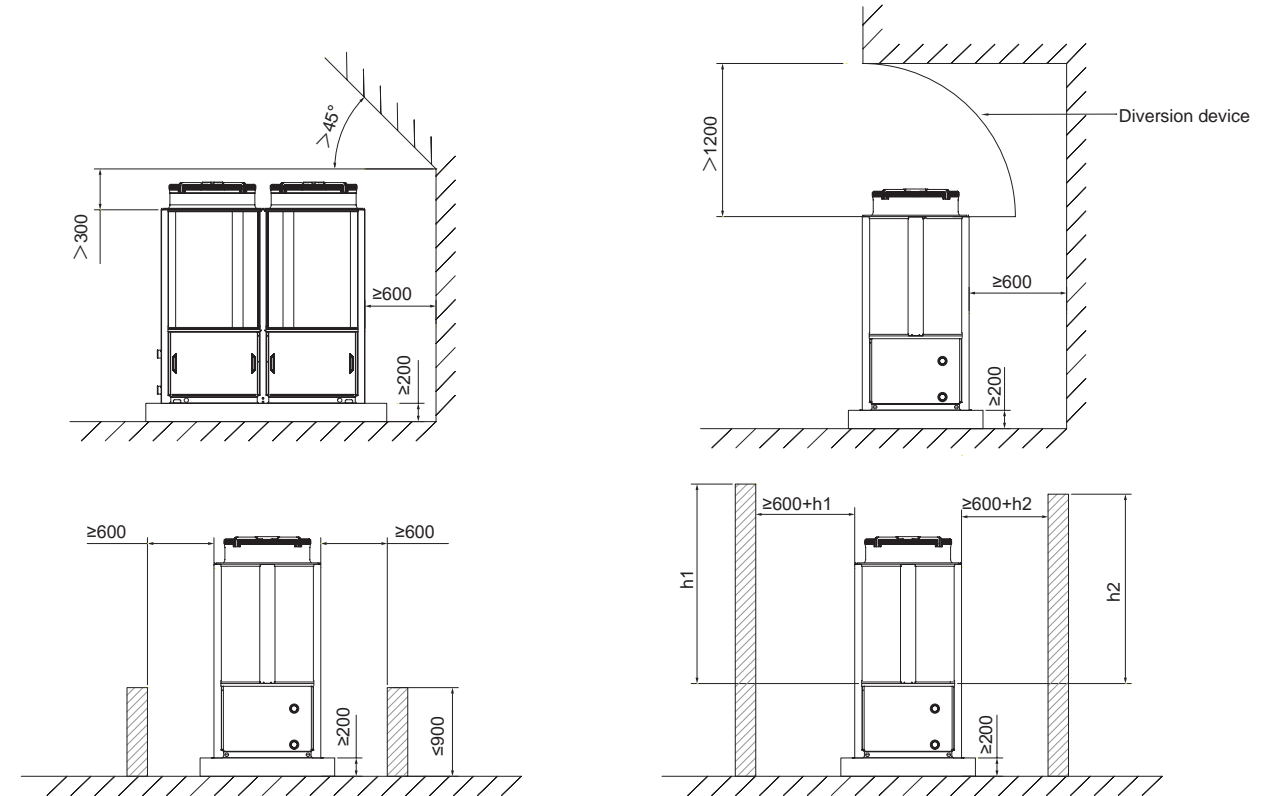

### Installation Basic Requirements

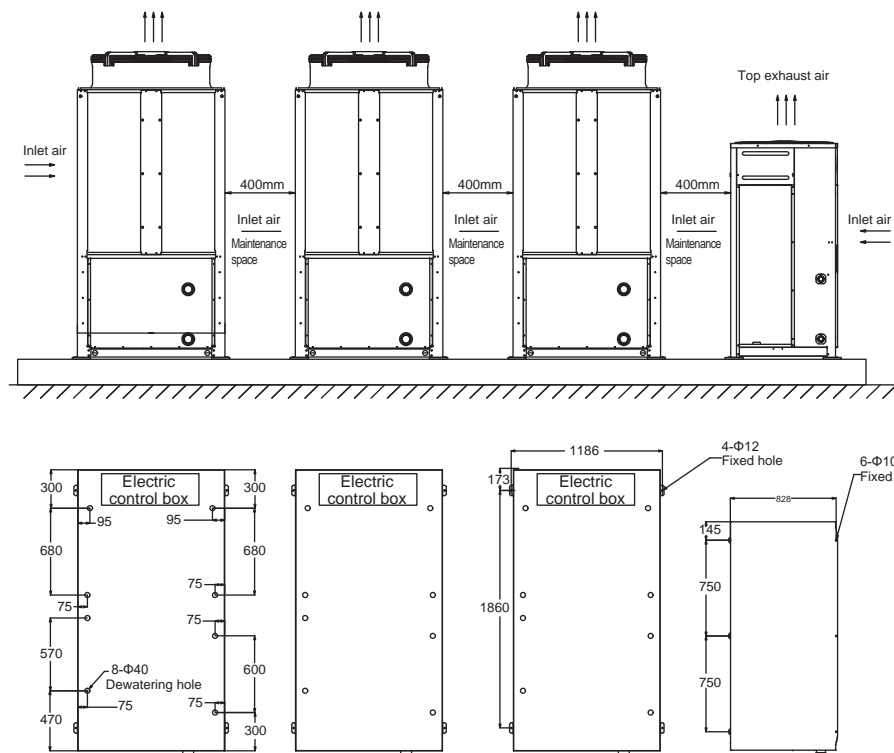

- Remarks:
1. At least 0.4 meters of space should be reserved around the unit, and the top of the unit should be unobstructed.
  2. The foundation can be a steel frame structure, such as channel steel, or a reinforced cement structure.
  3. The foundation should be completely horizontal, ensuring uniform contact between the units and sufficient strength to support the weight of the unit.
  4. Drainage ditches should be set up around the foundation to prevent water accumulation around the unit.
  5. There should be a shockproof pad with a thickness of no less than 10mm between the foundation and the unit.

Schematic diagram of Installation space requirements for multiple units

