

CONTENTS

1 External Appearance	3
2 Nomenclature	3
3 System Schematic	4
4 Specifications	5
5 BOM	6
6 Dimensions	8
7 Unit Installation	15
8 Application Examples.....	29
9 Pump Model Selection	43
10 Selection of Expansion Tank Volume and Preset Pressure	44
11 Final Check and Test Run	45
12 Piping Design	46
13 Wiring Diagram	47
14 Sound Levels	48
15 Accessories	50

1 External Appearance

Figure 1.1: Appearance



2 Nomenclature

4 T V M 0 0 4 8 E F 0 0 0 A A
 1 2 3 4 5 6 7 8 9 10 11 12 13 14 15

Legend		
No.	Code	Remarks
1	4	R-410A
2	T	Trane
3	V	TVR
4	M	Hydro Module
5	0	Currently not used
6	0	Btu/h x 1000
7	4	
8	8	
9	E	TVR Ultra
10	F	220-240/50/60/1
11	0	Currently not used
12	0	Currently not used
13	0	Currently not used
14	A	First design sequence
15	A	First service sequence

3 System Schematic

The following picture shows a schematic diagram using the High Temperature Hydraulic module and the TVR Ultra HR system. The below picture shows a detailed schematic of the TVR Ultra HR system using high temperature hydraulic module.

Figure 3.1: Hydraulic box connection method

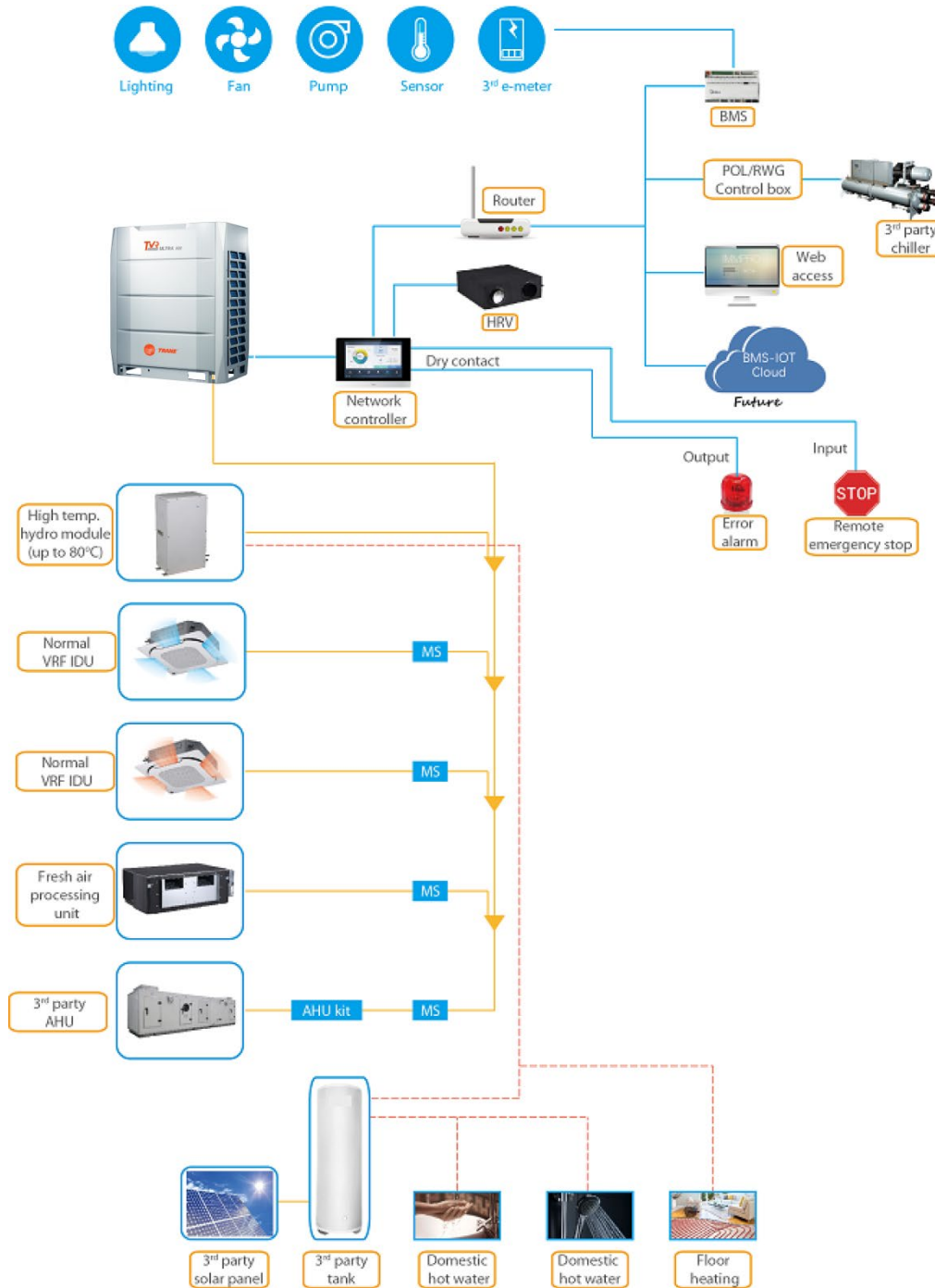

High Temperature Hydraulic Module

4 Specifications

4TVM0048EF000AA			
Power supply			1P~ 220-240V 50/60Hz
Heating Capacity	7/6°C OAT WIT: 40 / WOT: 45 °C	kW	14
Working range heating	HEAT	/	-20°C~30°C
	DHW	/	-20°C~43°C
ambient temperature range	/	/	0°C~40°C
sound pressure level	/	dB	43
water flow rate	nominal	m ³ /h	2.4
	min	m ³ /h	1.2
	max	m ³ /h	2.9
allowable water pressure	min	MPa	0.1
	max	MPa	1.0
Unit dimensions	Height	mm	795
	Width	mm	450
	Depth	mm	300
Refrigerant pipes connection	Connection type		External Screw Thread
	Liquid pipe diameter	mm	Ø9.52
	Gas pipe diameter	mm	Ø12.7
water pipes connection	Connection type		External Screw Threads
	Inlet pipe diameter	mm	25
	Outlet pipe diameter	mm	25

5 BOM

High Temperature Hydraulic Module

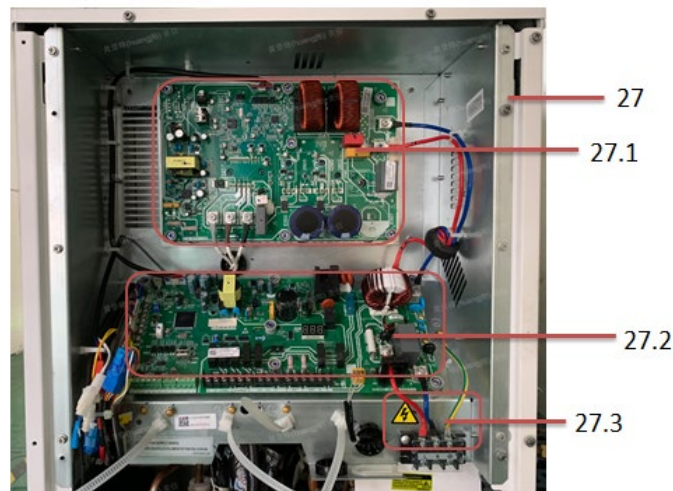
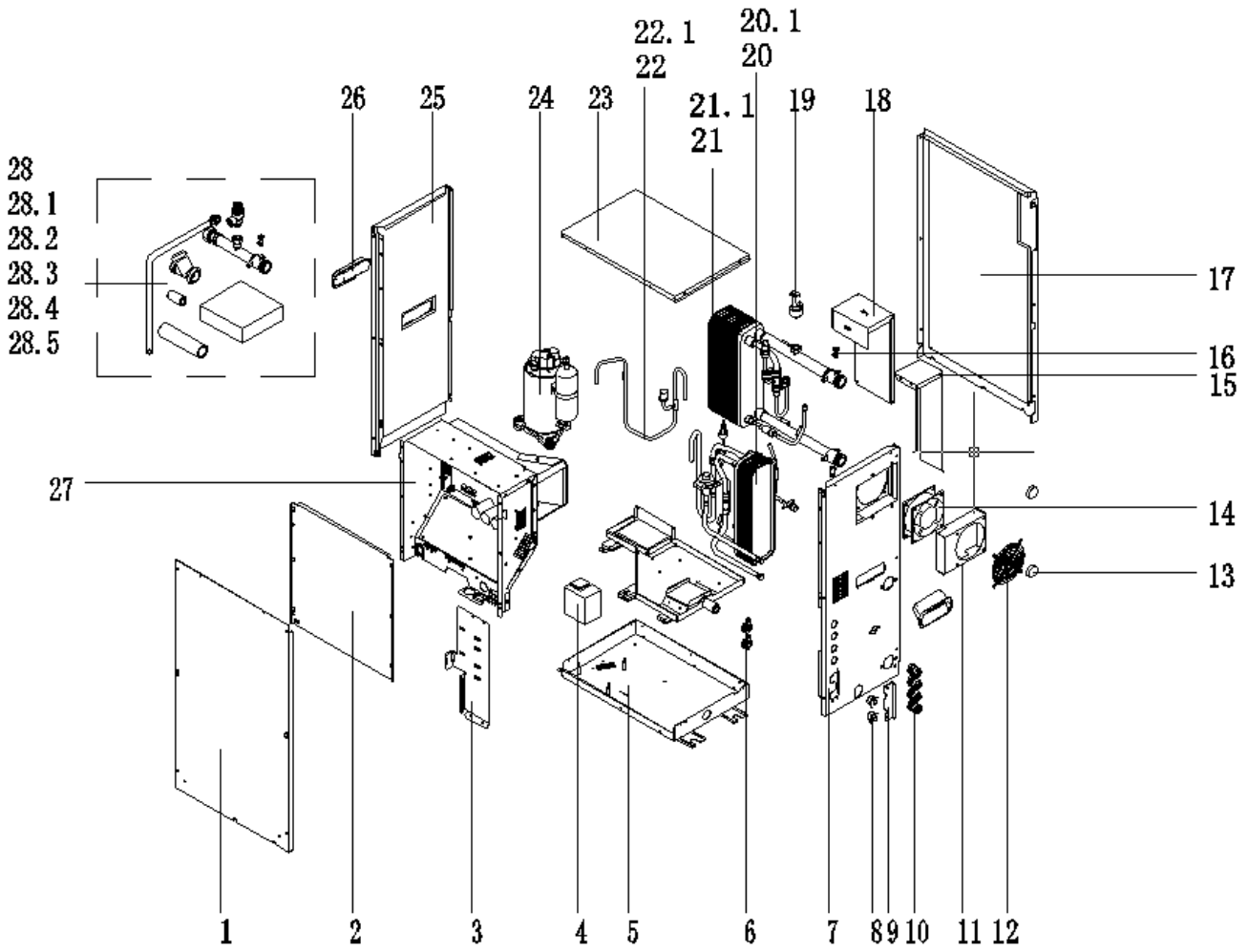

1	Front panel assembly
2	Electric control box cover assembly
3	Connecting plate
4	Pearl cotton
5	Chassis assembly
6	Pressure pipe clamp
7	Right panel assembly
8	Rubber washer
9	Connecting plate
10	Cable gland
11	Connecting plate
12	Grill
13	Dust plug
14	AC fan
15	Connecting plate
16	Drainage pipe adapter
17	Rear panel assembly
18	Connecting plate assembly
19	Flow Switch (RoHS)
20	Plate heat exchanger assembly
20.1	Plate heat exchanger assembly
21	Plate heat exchanger assembly
21.1	Plate heat exchanger assembly
22	Air discharge pipe assembly
22.1	Pressure switch
23	Top cover assembly
24	DC Inverter rotary compressor
25	Left panel assembly
26	Handle
27	E-part box assembly
27.1	Power drive mounting plate assembly
27.2	Hydraulic module, Main control board assembly
27.3	Wire joint
28	Accessory package
28.1	Connecting pipe assembly
28.2	Y shape filter
28.3	Accessory- Drainage hose
28.4	Wired controller
28.5	Magnetic ring
29	Water temperature sensor
30	Water temperature sensor
31	Pipe Temperature Sensor
32	Pipe Temperature Sensor
33	Pipe Temperature Sensor

6 Dimensions

6.1 Structural Dimensions

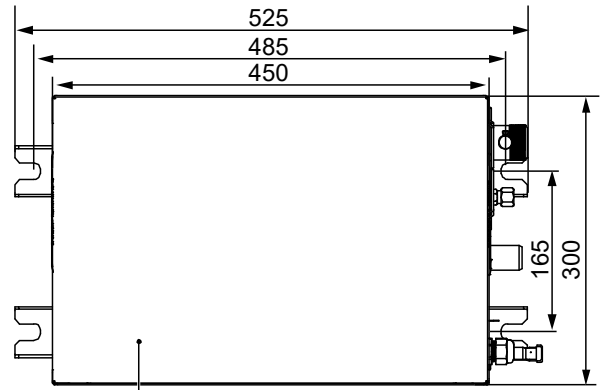
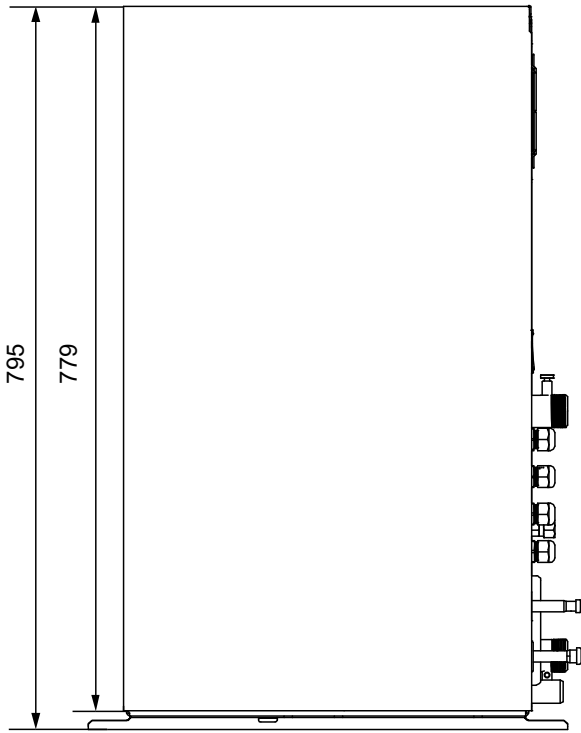

Hydro module unit (top view)

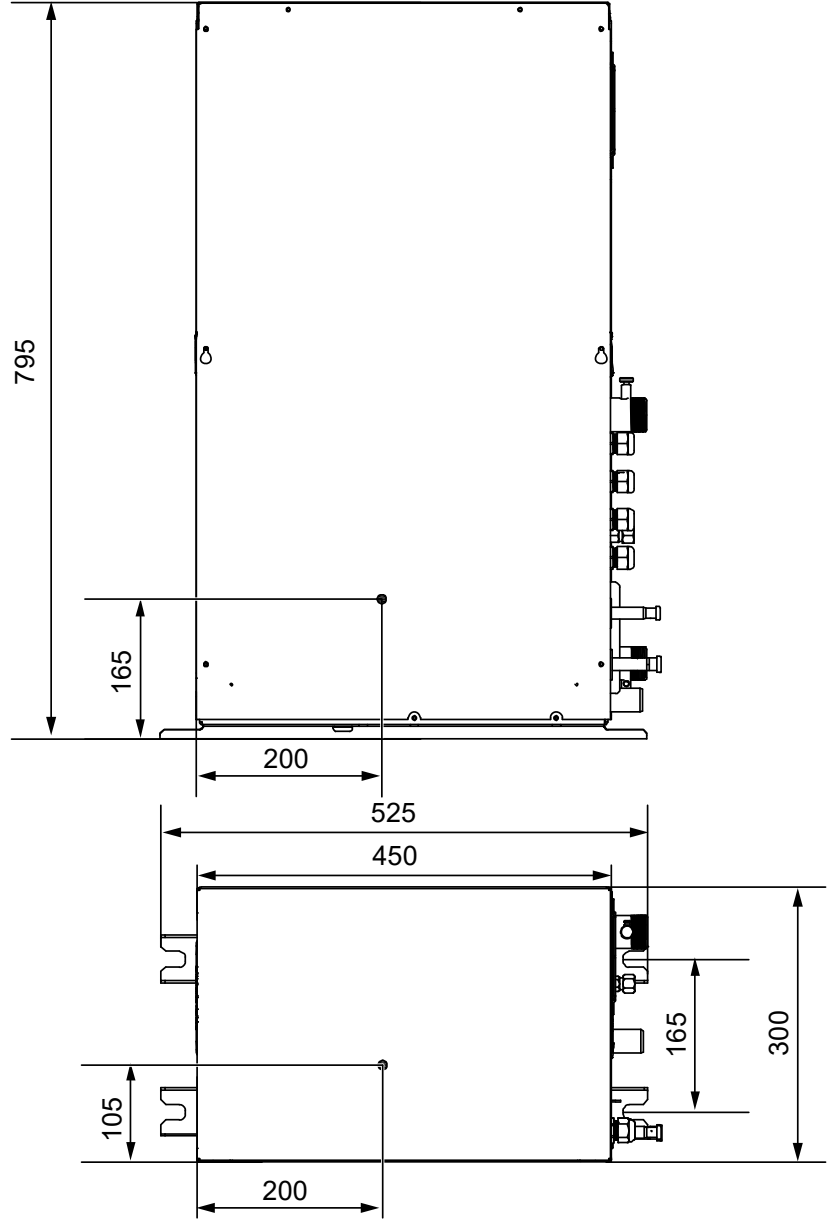
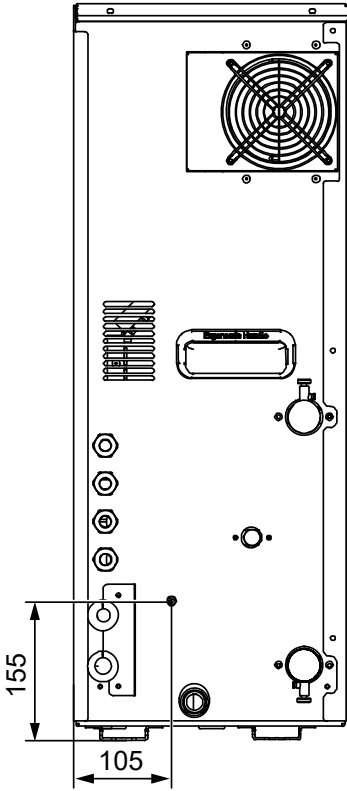
6.2 Center of gravity

6.3 Installation Space

High Temperature Hydraulic Module

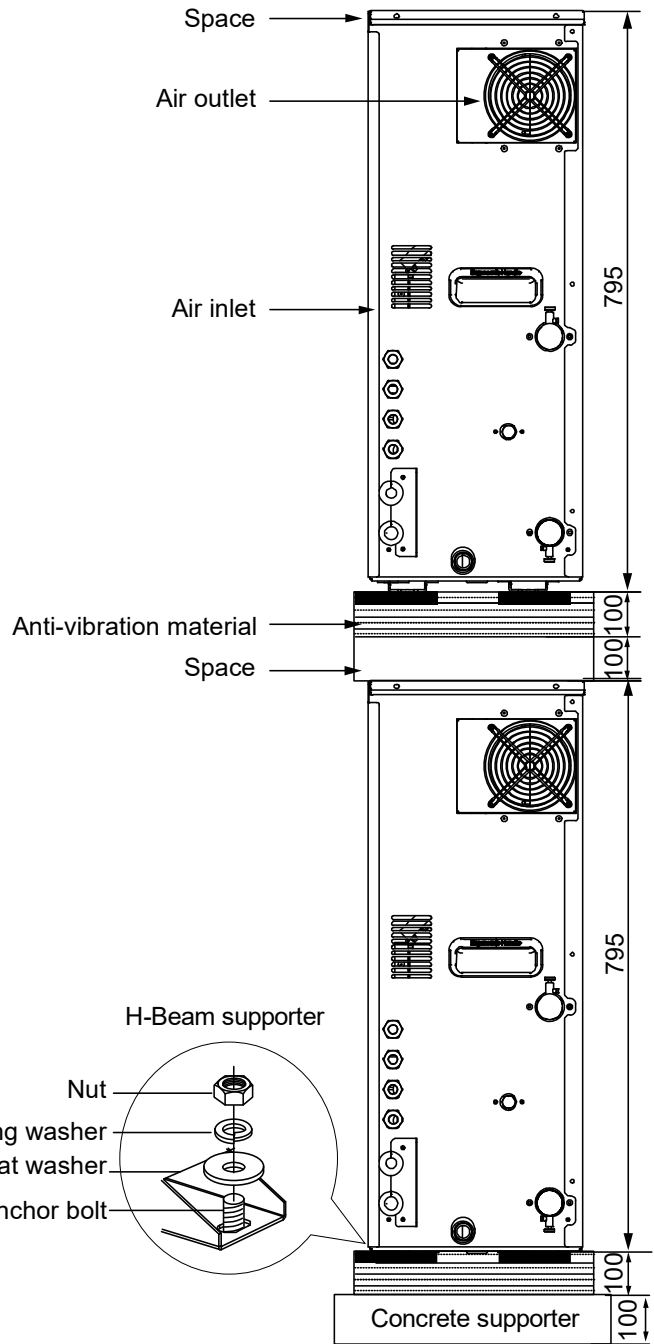
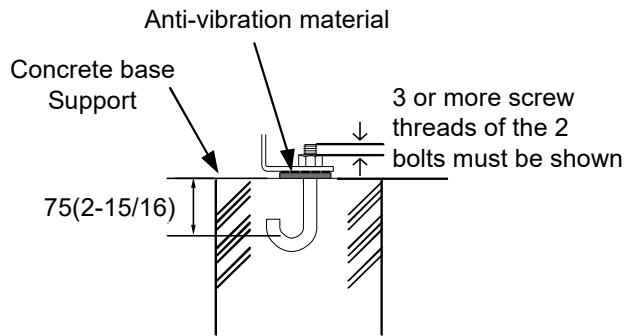
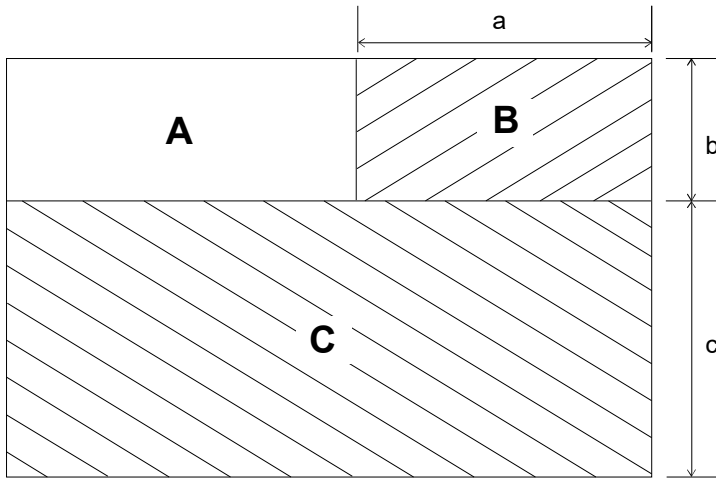

A	High Temperature Hydraulic module
B	Space for installing piping (on the right side)
C	Space for installation and maintenance (in the front)

6.4 General Precautions about Installation Site

Select an installation site that meets the following conditions:

- The floor that supports unit weight should be hard enough. The floor should be level to avoid vibration and noise.
- The space around the unit should be wide enough for maintenance and repair. The space dimensions are as follows: $a \geq 400$ mm; $b \geq 300$ mm; $c \geq 600$ mm. If double-layer installation is required, the upper and lower space between units should be not less than 150 mm.
- There should be enough space around the unit for ventilation.
- If flammable gas leaks, ensure that there are no hazards that could lead to fire.
- This unit is not designed to operate in an environment where explosions could occur.
- Select the installation site according to the corresponding legal provisions. The noise should not affect any person. Carefully select an installation site. Do not install the unit in an environment that is sensitive to sound, such as living rooms and bedrooms.
- If water leaks, the leakage should not cause damage to the installation site or the surroundings.
- Take enough measures according to the corresponding legal provisions to deal with refrigerant leakage.
- When the unit is installed in a small room, take measures to ensure that concentration of the leaking refrigerant cannot exceed the allowed limit.
- Do not climb, sit on, or stand on the unit.
- Do not place any article or equipment on the top of the unit (top panel of the unit).
- Do not install the unit in a workshop, for example, a construction site, because at construction sites, the equipment will be covered in dust.
- Do not install the unit in a highly damp site, such as a restroom. (The maximum relative humidity is 85%.)
- When installing the unit, reserve enough space for the air inlet and air outlet. Do not obstruct them.

Notes for installers and service engineers

Caution

In an airtight space, excessively high concentration of the refrigerant may lead to insufficient oxygen.

6.5 General precautions about the Water System

Check the following items before continuing installation:

- Max. hydraulic pressure: 10 bar
- Max. water temperature: 80 °C
- Install enough safety devices in the water loops to ensure that the hydraulic pressure does not exceed the maximum operating pressure (10 bar).
- Provide a drainage hole at all the low points of the system so that the water is completely drained from the water system when you repair or maintain the unit. A drain valve has been installed at the water inlet to facilitate water discharge from the unit's water system.
- Ensure that you have provided a suitable water discharge pipe to the safety valve to prevent water from coming into contact with any electrical part. A water discharge pipe has been provided with the unit.
- You must deploy air outlets at all the high points of the system. The air outlets should be deployed at the places where they can be easily maintained. A drain valve has been installed at the water outlet to facilitate air discharge from the unit's water system.
- Ensure that all the components installed on pipes on site can bear water pressure and water temperature.
- You should use materials that are compatible with water and equipment in the system.
- Anti-freezing protection of the water system:
- Freezing may cause damage to the system. The ODU may be exposed to temperatures below 0 C. You must prevent the system from freezing.
- All the internal water systems are insulated to prevent heat loss. On site, pipes should be fitted with insulating materials.
- The unit is designed with an anti-freezing function. The unit uses a heat pump to prevent the entire system from freezing. When the water temperature in the system decreases to a certain value, the unit will heat water. The anti-freezing function will be disabled only when the water temperature rises to a certain value.
- In the event of power failure, the anti-freezing function cannot protect the unit from freezing.
- Using anti-freezing liquid in the water system is recommended, because power failure may happen when no one is present.
- Ensure that the water system is full of the ethylene glycol concentration provided in the following table, according to the expected lowest outdoor temperature. When ethylene glycol is added to the system, device performance will be affected. The following table lists the correction coefficients of the unit capacity, flow, and pressure drop of the system.

<i>Ethylene Glycol</i>					
Quality of Glycol %	Modification Coefficient				Freezing Point in degree C
	Cooling Capacity Modification	Power Modification	Water Resistance	Water Flow Modification	
0	1.000	1.000	1.000	1.000	0.0000
10	0.984	0.998	1.118	1.019	-4.000
20	0.973	0.995	1.268	1.051	-9.000
30	0.965	0.992	1.482	1.092	-16.000
40	0.960	0.989	1.791	1.145	-23.000
50	0.950	0.983	2.100	1.200	-37.000

<i>Propylene Glycol</i>					
Quality of Glycol %	Modification Coefficient				Freezing Point in degree C
	Cooling Capacity Modification	Power Modification	Water Resistance	Water Flow Modification	
0	1.000	1.000	1.000	1.000	0.0000
10	0.976	0.996	1.071	1.000	-3.000
20	0.961	0.992	1.189	1.016	-7.000
30	0.948	0.988	1.380	1.034	-13.000
40	0.938	0.984	1.728	1.078	-22.000
50	0.925	0.975	2.150	1.125	-35.000

- If ethylene glycol is not added, water must be discharged when power is cut off

6.6 Checking, Handling and Unpacking the Unit

- When the unit is delivered, you must check the equipment and immediately report damage (if any) to the claims agent of the carrier.
- Put the packaged unit as close as possible to its final installation site to prevent damage during the handling process.
- Check all the accessories of the IDU. (For details, see “1. Accessories” on page 1.)

Notes for installers and service engineers

Caution

- Remove the plastic packaging bag so that children cannot play with it. Children may face the danger of death by suffocation if playing with the plastic packaging bag.
- Both ethylene glycol and propylene glycol are toxic substances. The concentration mentioned in the preceding table cannot prevent freezing, but can prevent breaking caused by liquid pressure.

High Temperature Hydro Module



6.7 Installation Diagram

High Temperature Hydraulic Module

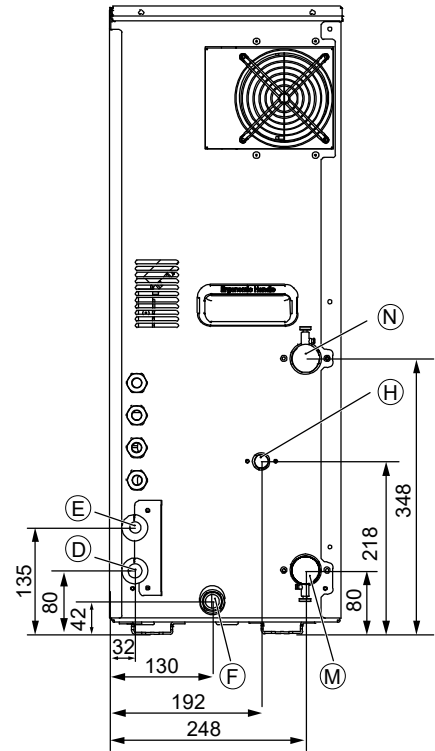
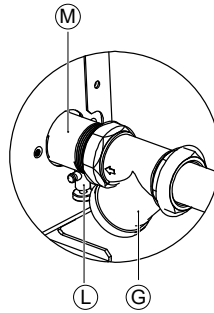
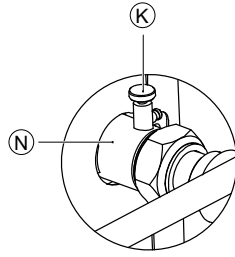
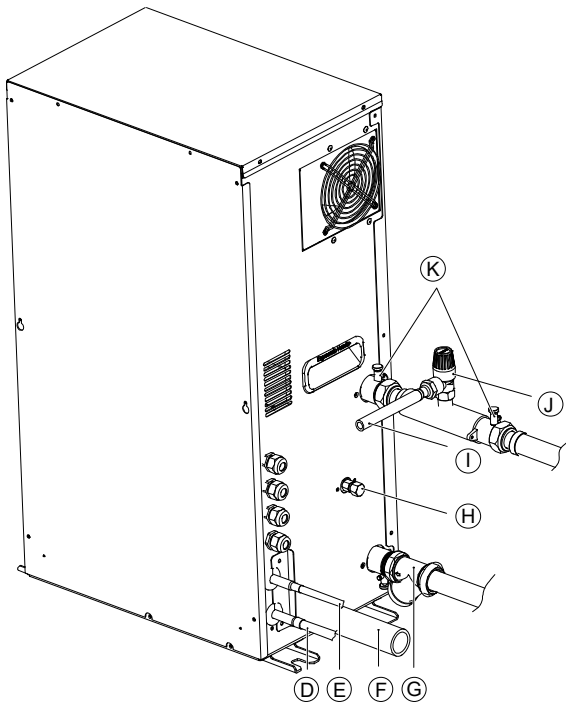

- ⓓ Liquid pipe (connected to the ODU)
- ⓔ Gas pipe (connected to the ODU)
- ⓕ Water discharge pipe (drainage pan)
- ⓖ Y-shaped filter
- ⓗ Access hole (for charging/discharging refrigerant)
- Ⓢ Water discharge pipe (safety valve)
- Ⓣ Safety valve
- Ⓚ Discharge valve
- Ⓛ Drain valve
- Ⓜ Water inlet
- Ⓝ Water outlet

7 Unit Installation

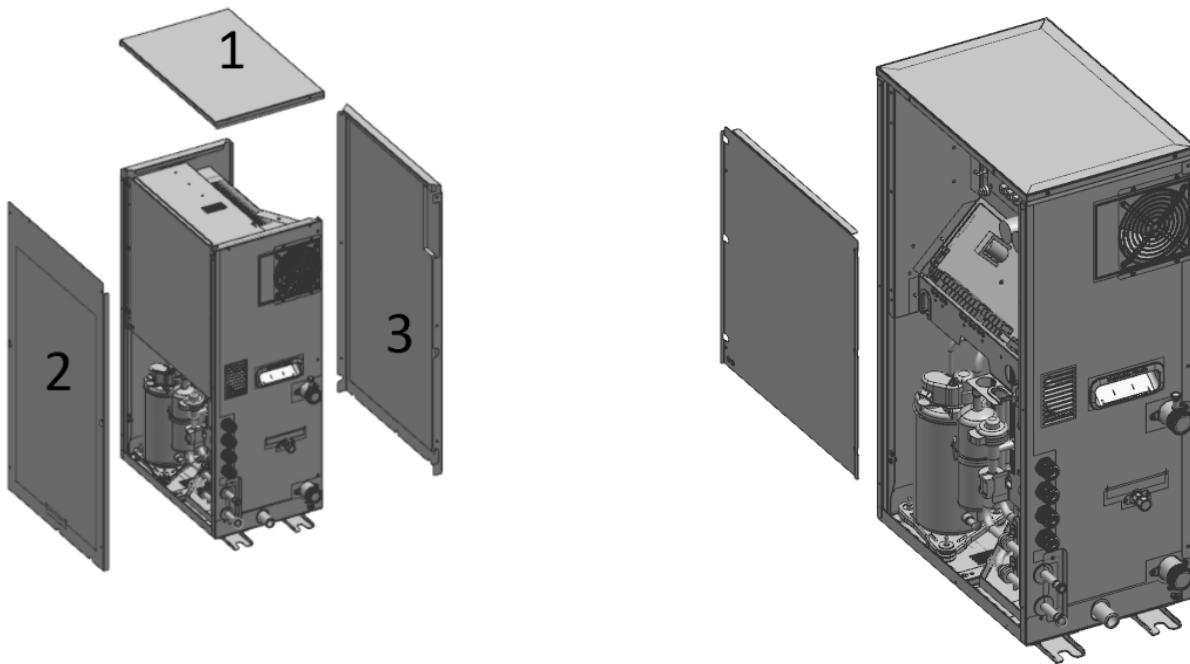

Notes for installers and service engineers

Caution

The unit should be installed by professional installation operators. Material selection and installation must confirm with the local legal provisions.

- To check the interior of the unit, open the top panel, front panel, and rear panel first. After you open these three panels, you can see the main parts of the unit. If you just install or maintain the internal parts of the electric control box, you need to open the front panel without needing to open the top or rear panel.

- 1 Top panel
- 2 Front panel
- 3 Rear panel

To open the electric control box and operate the interior of the electric control box, open the electric control box cover plate. To open the electric control box, you can open the front panel without needing to open the top or rear panel.

High Temperature Hydro Module



Main parts of the unit

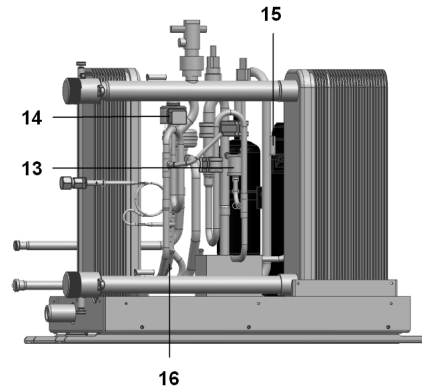
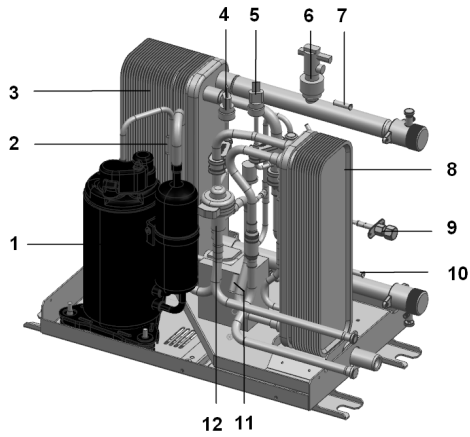

High Temperature Hydraulic Module

1	Compressor	9	Access hole
2	Discharge temperature sensor	10	Water inlet temperature sensor
3	Plate heat exchanger used by the condenser	11	Liquid pipe temperature sensor at the outlet on the R410A refrigerant side
4	Low pressure sensor	12	Electronic expansion valve on the R410A loop
5	High pressure sensor	13	High pressure switch
6	Water flow switch	14	Electronic expansion valve on the R134a loop
7	Water outlet temperature sensor	15	Suction temperature sensor
8	Plate heat exchanger used by the evaporator	16	Cold outlet temperature sensor on the R134a refrigerant side

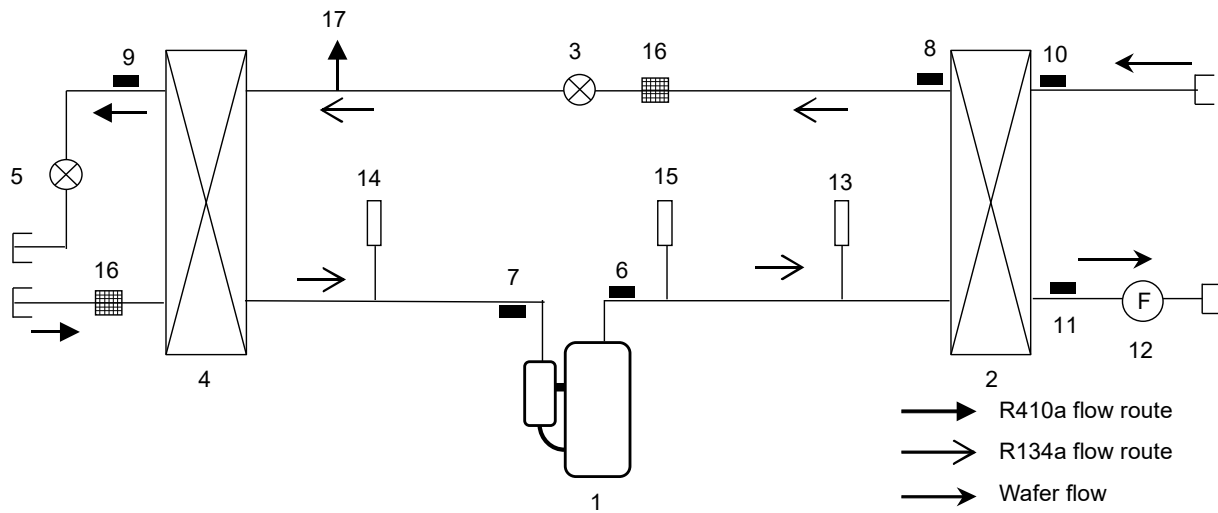

1	Compressor	10	Water inlet temperature sensor
2	Plate heat exchanger used by the condenser	11	Water outlet temperature sensor
3	Electronic expansion valve on the R134a loop	12	Water flow switch
4	Plate heat exchanger used by the evaporator	13	High pressure sensor
5	Electronic expansion valve on the R410A loop	14	Low pressure sensor
6	Discharge temperature sensor	15	High pressure switch
7	Suction temperature sensor	16	Filter
8	Cold outlet temperature sensor on the R134a refrigerant side	17	Access hole
9	Liquid pipe temperature sensor at the outlet on the R410A refrigerant side		

- Connecting pipes on the refrigerant side and water system side
- Use screw thread to connect the pipe on the water system side. Tighten the pipe to avoid water leakage.
- Brazing is required on the refrigerant side.

Notes for installers and service engineers

Brazing Precautions

- In the event of brazing, please use nitrogen for sweeping. This can prevent the occurrence of oxidation inside pipes. Oxidation will have adverse effects on the valves and compressors in the cooling system, and may hamper normal operations.
- Use the pressure relief valve to set the nitrogen pressure to 0.02 MPa (a pressure that can just be felt by the skin).
- Do not use antioxidants when brazing pipe connectors. Residues will block pipes and damage equipment.
- Do not use a flux when brazing copper refrigerant pipes. Use copper-phosphorus alloys (BCuP) where no flux is required.
- Flux is harmful to the cooling pipe system. For example, if a chlorine-based flux is used, pipes will be

High Temperature Hydro Module



Connecting wires

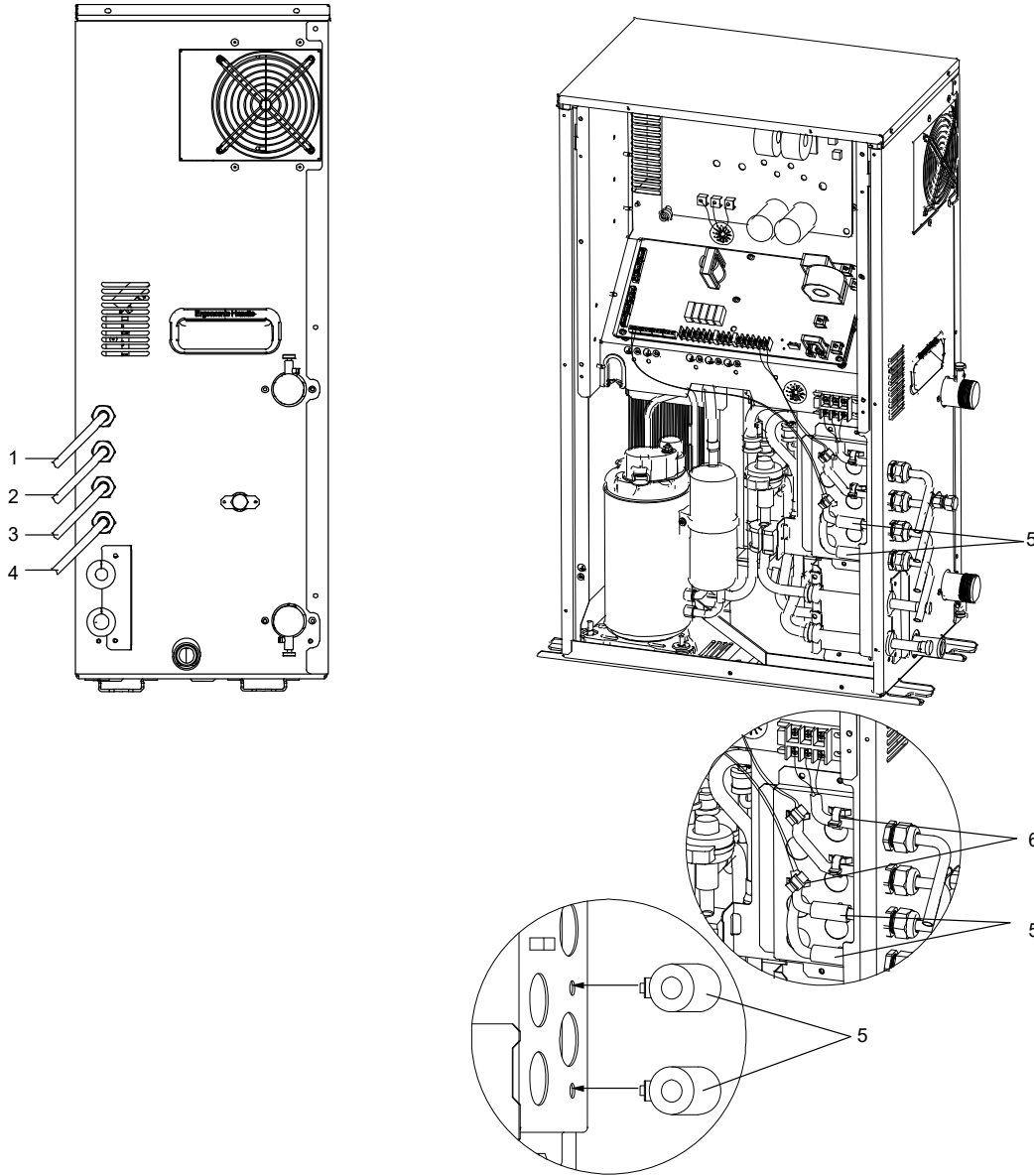

High Temperature Hydraulic Module

1	Power input
2	High Voltage Signal
3	Low Voltage Signal
4	Communication Cables
5	Magnetic Ring
6	Cable Tie

- When the external wire enters the interior of the unit through a waterproof cable connector, you need to separate the strong-current cable from the weak-current cable for cabling. For details, see the diagram.
- Inside the unit, wires should be fixed by using a cable tie through the overpass-shape component.
- Both the signal cable and output cable must be fitted with a magnetic ring, and then fixed on the overpass-shaped component by using a cable tie.

- Connection for other components

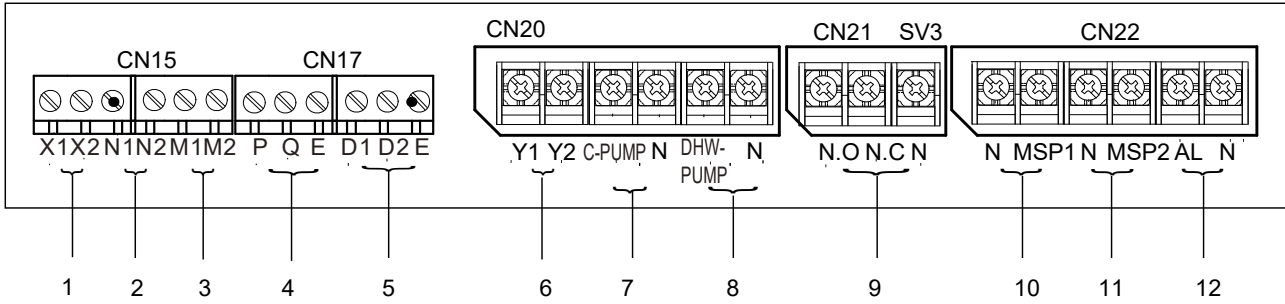

Coding	Assembly unit	Coding	Assembly unit
1	Connecting the wired controller	7	Connecting the circulating water pump AC contactor
2	Free electrical signal	8	Connecting the AC contactor for controlling water tanks and water pumps
3	Cheap electrical signal	9	Connecting the three-way valve
4	Outdoor/MS units communication .bus	10	Energy demand adjustment 1 input
5	Hydraulic module group control interface/connecting to the KNX gateway	11	Energy demand adjustment 2 input
6	Reserved	12	Alarm output -230 V~

- Wired controller wiring

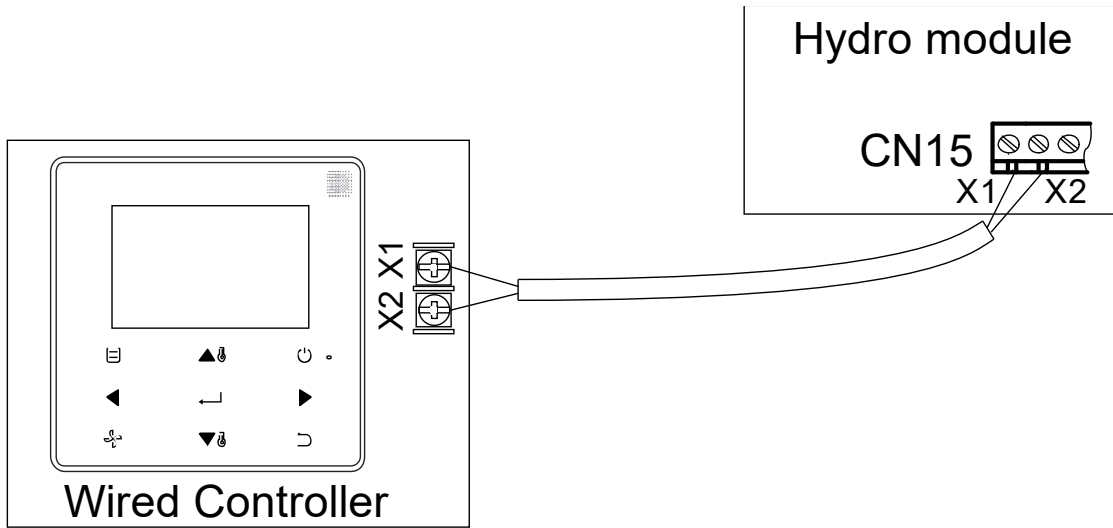

- Wires X1 and X2 do not have polarity requirements.

Voltage	18 V DC
Maximum running current (A)	0.1
Wiring size (mm ²)	2x0.5

- Free electrical signal port N1/N2
- Cheap electrical signal port M1/M2

Used for energy management and to identify cheap or free electricity. When N1 is connected to N2, the electricity is determined to be free electricity. When M1 is connected to M2, the electricity is determined to be cheap electricity. When receiving cheap or free electrical signal, the hydraulic module will automatically start. (For detailed settings, refer to the Service Manual)

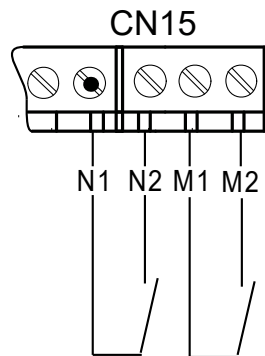

Voltage	12 V DC
Maximum running current (A)	< 0.1
Wiring size (mm ²)	2x0.5

- Connection line group for IDU and ODU / MS communication

Used to connect IDU and ODU communication and transfer the control signals of the IDU and ODU. Please use the wire with a shield layer and ensure that the shield layer is grounded. For instructions on how to connect the ODU or MS, please see the corresponding manual.

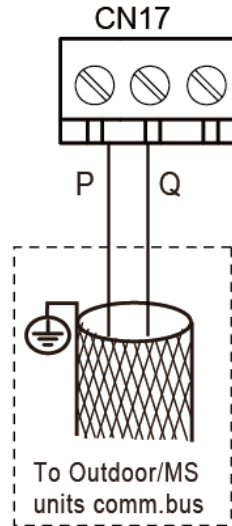

Voltage	2.5~2.7 V DC
Maximum running current (A)	< 0.1
Wiring size (mm ²)	2x0.75 shielded cable

- Group control connection method/KNX gateway connection method
- The hydraulic module can provide the function of group control so that one module can control multiple units. In the entire system, only one master wired controller can be deployed to control units. Each unit can connect one slave wired controller for data query.
- Up to 10 units can be controlled.

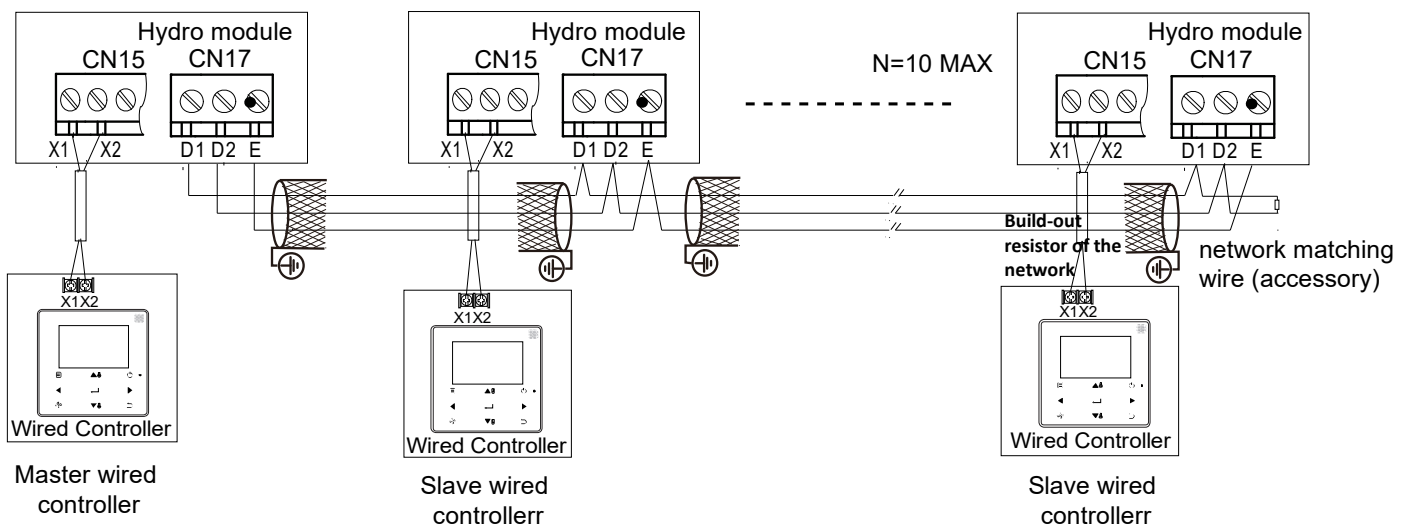

- The hydraulic module can connect the KNX gateway via D1\D2\E so that the third-party wired controller can control the hydraulic module. In this case, X1 and X2 can be used for check query by connecting or without connecting the wired controller, but cannot be used for control.

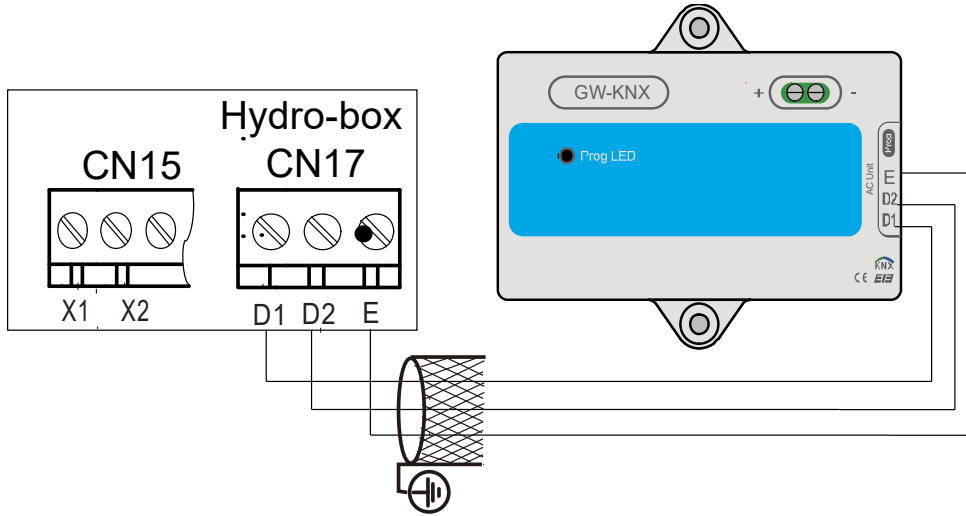

Voltage	2.5~2.7 V DC
Maximum running current (A)	< 0.1
Wiring size (mm ²)	3x0.75 shielded cable

- Reserving Y1/Y2 at port
- Output control interface of the circulating water pump
- Output control interface of the water tank and water pump

Note: The circulating water pump, water tank and water pump are connected to an external contactor for control. Do not directly connect the water pump.

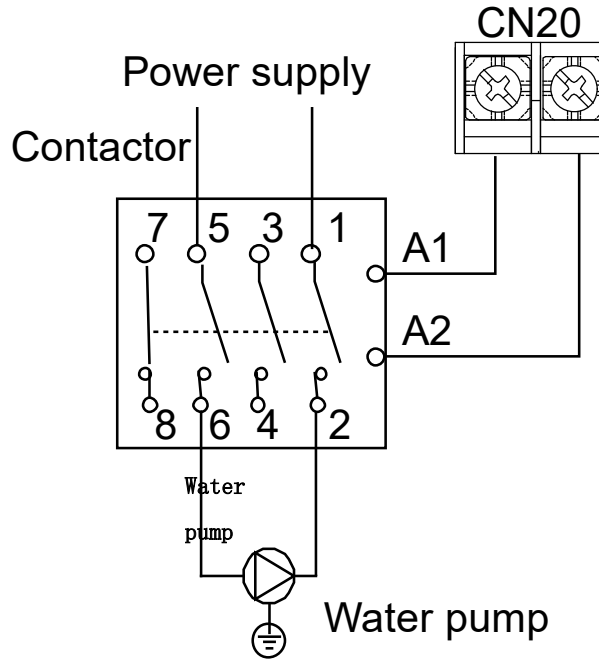

Voltage	220-240V
Maximum running current (A)	2
Wiring size (mm ²)	2x0.75

- Controlling ports via a three-way valve

The three-way valve offers the following two methods, subject to the models sold in the market. For details, see the three-way valve manual. N.O indicates normally open output, while N.C indicates normally closed output.

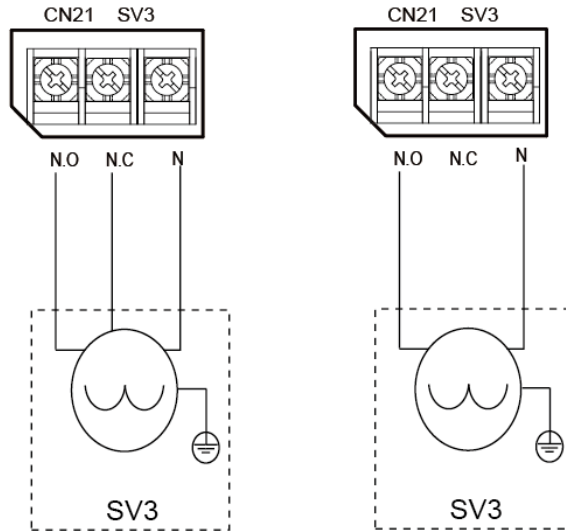

Voltage	220-240V~
Maximum running current (A)	1
Wiring size (mm ²)	3x0.75

- Three-way valve installation**

Check the three-way valve type. Connect it to the electric control board. For instructions on how to connect ports and wires.

Note: Before installing the three-way valve, check the port opening direction.

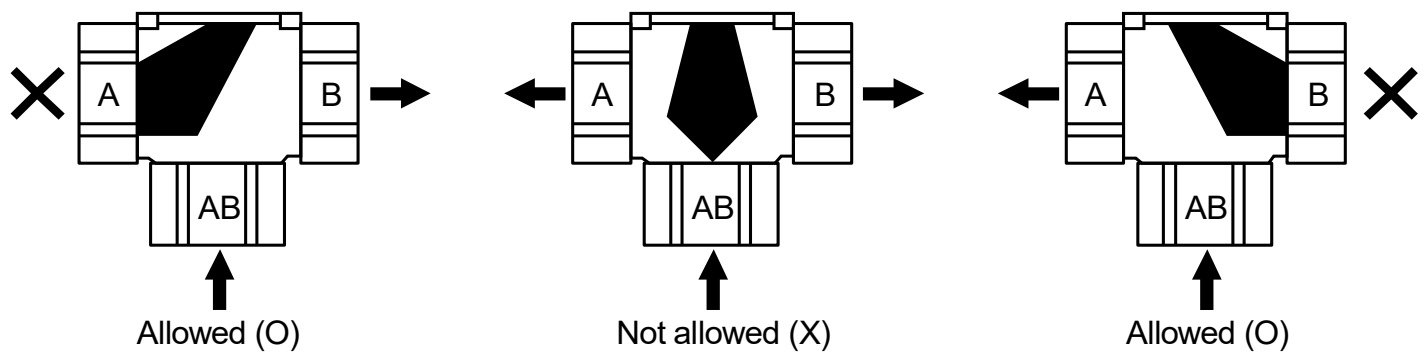

- Input port 1 of temperature multiple set point
- Input port 1 of temperature multiple set point

To set the temperature at multiple points, connect a third-party thermostat to set different temperature set points.

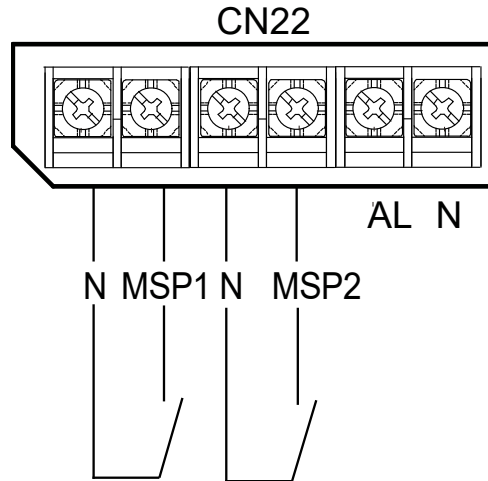

Voltage	220-240V~
Maximum running current (A)	< 0.1
Wiring size (mm ²)	2x0.75

- **Alarm output signal**

When the unit fails, a signal can be output to indicate the unit status.

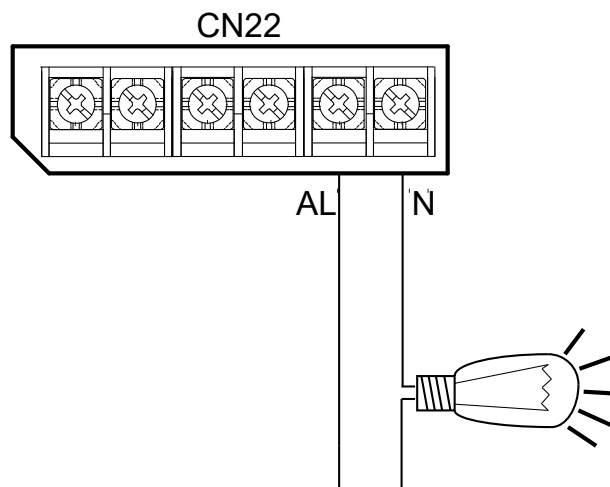

Voltage	220-240V~
Maximum running current (A)	2
Wiring size (mm ²)	2x0.75

Note: After wires are connected, do not place the redundant wires into the unit.

High Temperature Hydro Module



- **Installing the wired controller**

This unit is equipped with a wired controller, which is used to set, operate, and maintain this unit. Before operating the wired controller, please follow the installation procedures.

Notes for installers and service engineers

Caution

- The connecting wire is excluded tank temperature. The hydraulic module controls the three-way valve to switch to heating or DHW modes.
- The wired controller is delivered as a kit and must be installed indoors.
- When the temperature control function of the wired controller is used, please select an installation site that satisfies the following conditions:
 - The average temperature of the room can be detected.
 - The installation site is free from direct sunshine.
 - The installation site is not near the heat source and the temperature is between 0 °C and 50 °C.
 - The installation site is not affected by outdoor air or air pressure, for example, opening/closing of the door.
 - The display can be kept clean.

- **Wired controller dimensions**

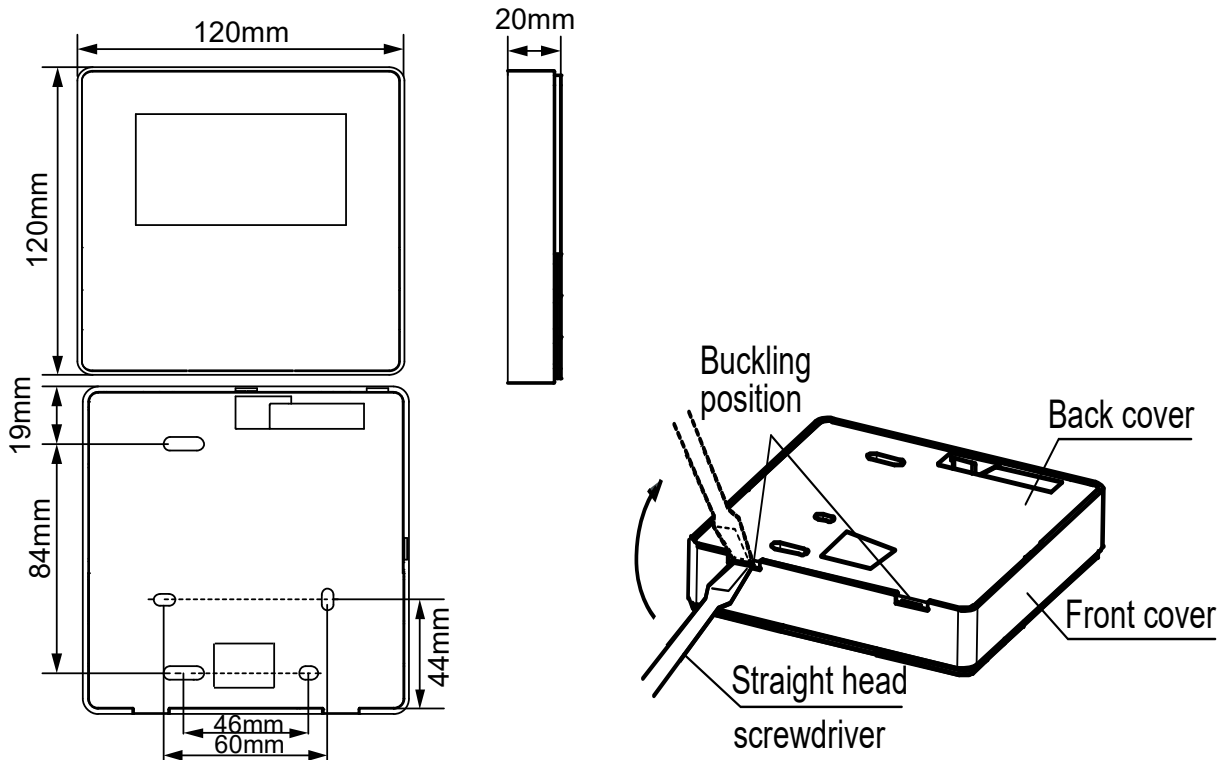

- ① Insert the tip of a straight head screwdriver into the bending location at the bottom of the wired controller. Raise the screwdriver to pry open the rear cover. Pay attention to the direction when prying open the rear cover. Prying in an incorrect direction will damage the rear cover.

- ② Fix the rear cover on the wall.

Note: Do not excessively tighten the installation screws to prevent rear cover deformation of the wired controller.

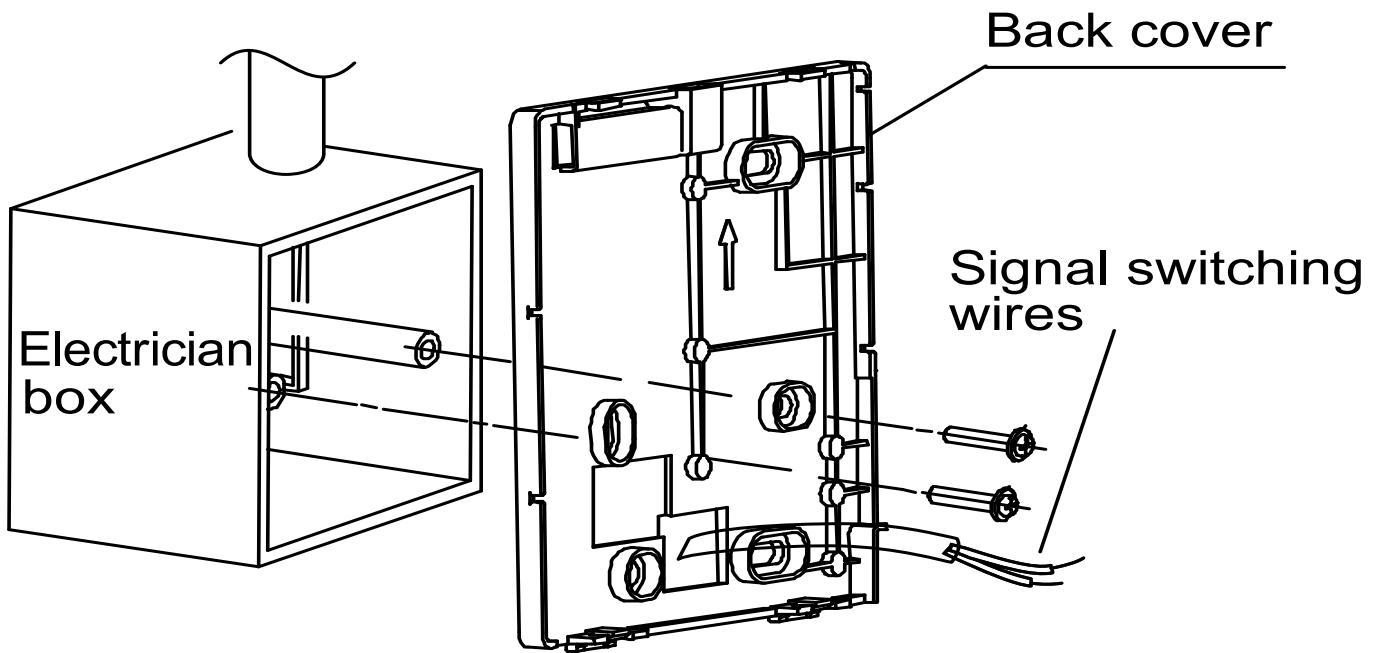
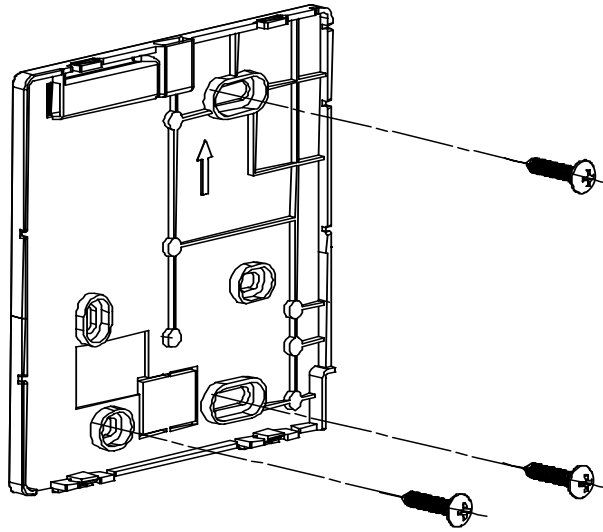

High Temperature Hydro Module



③ Wire the wired controller.

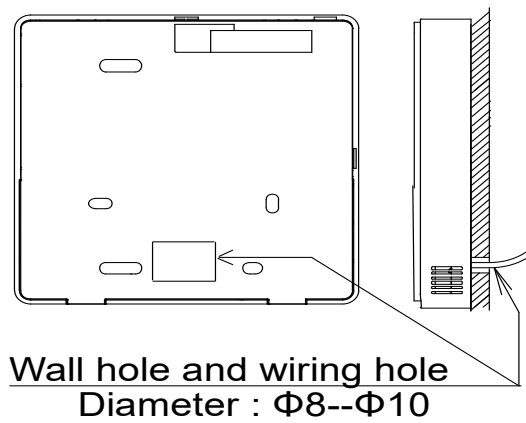
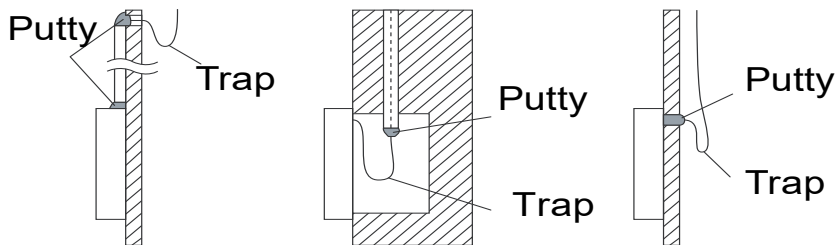
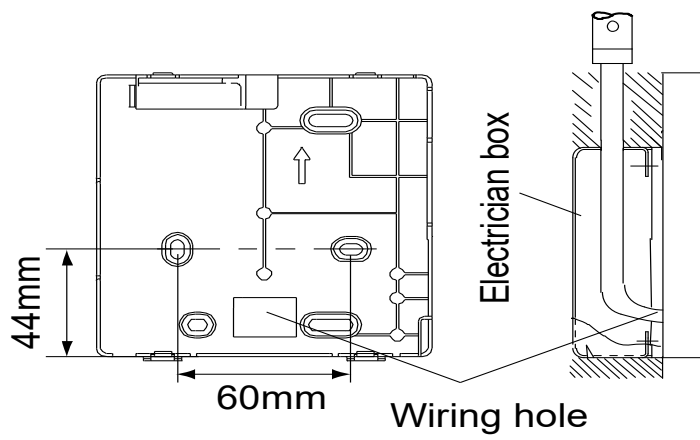
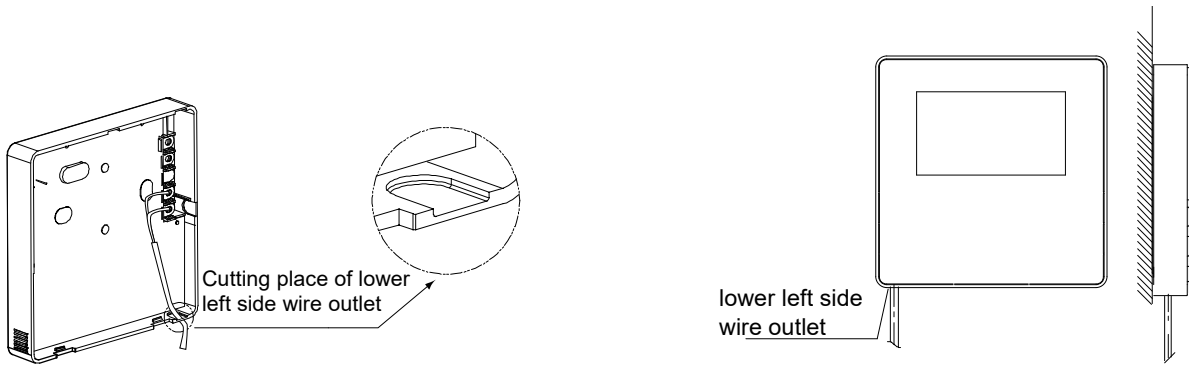

④ Connect the wired controller to the unit.

Note: * Do not jam wires during installation.

8 Application Examples

Only heating mode is available and the heating mode operates in water outlet temperature control mode.

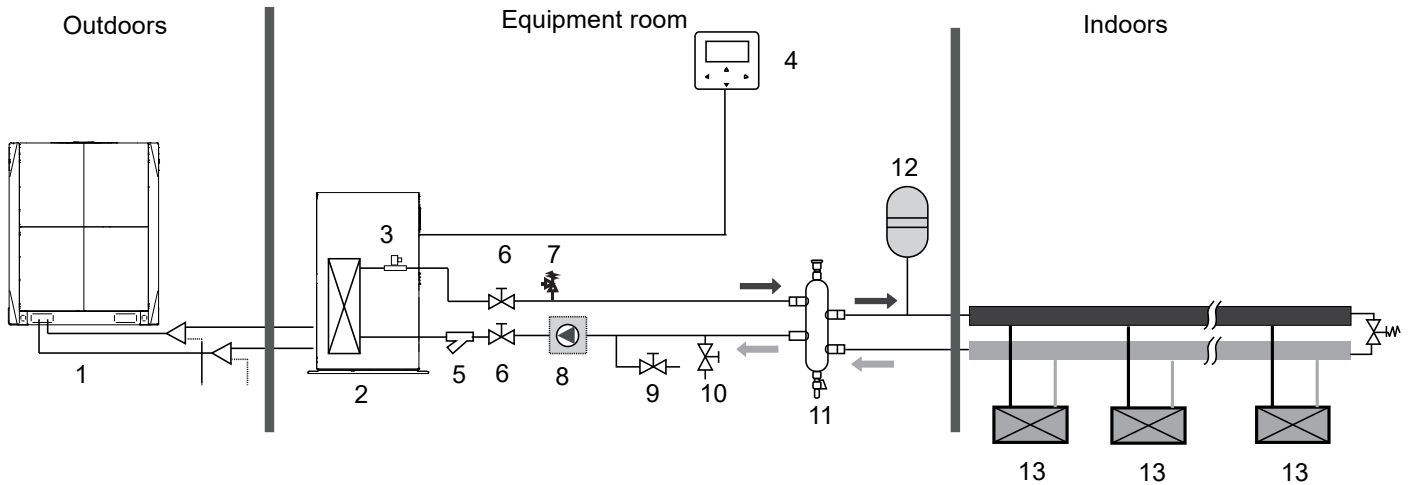

1	ODU
2	Hydraulic module
3	Water flow switch
4	Wired controller (Accessory)
5	Y-shaped filter (Accessory)
6	Check valve (Provided on site)
7	Safety valve (Accessory)
8	Water pump (Provided on site. For model selection, see page 32.)
9	Drain valve (Provided on site)
10	Water replenishing valve (Provided on site)
11	Water collector (Provided on site)
12	Water expansion tank (Provided on site. For model selection, see page 33.)
13	Terminals. The unit can connect to the floor heating device FHL (25 °C-45 °C), fan coil FCU (45 °C-60 °C), and radiator (60 °C-80 °C), which have different temperature requirements.

On-site settings of the wired controller:

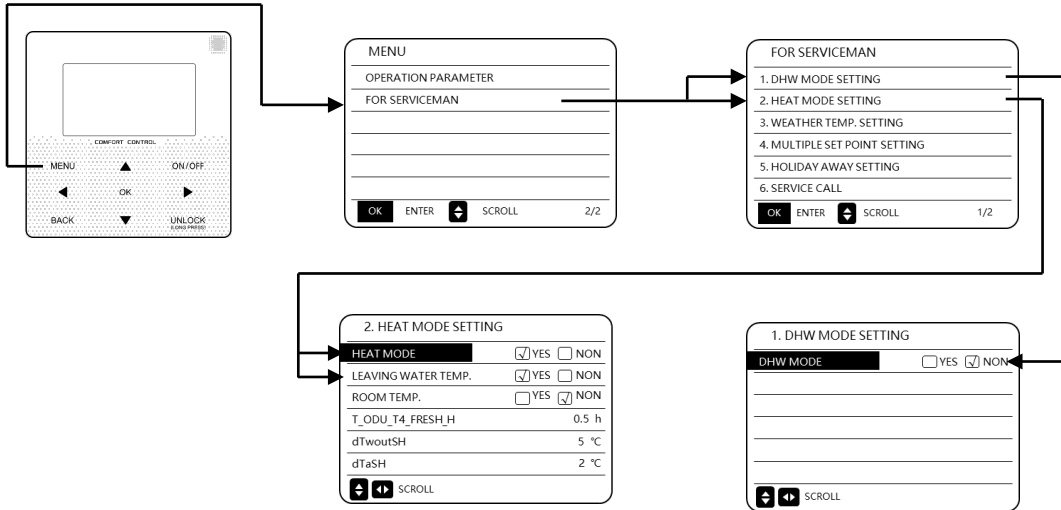

HEAT MODE=YES
Heat mode is valid.
LEAVING WATER
TEMP.=YES
Water outlet temperature
control is valid.

DHW MODE=NON
DHW mode is
invalid.

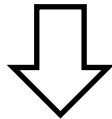

Temperature
settings

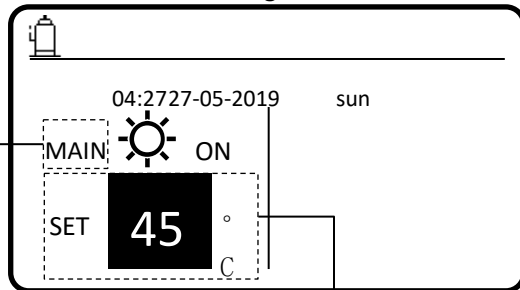

MAIN indicates water
outlet temperature
control.

Sets the desired water
outlet temperature,
ranging from 25 C to 80 C.

Only heating mode is available and the heating mode operates in room temperature control mode.

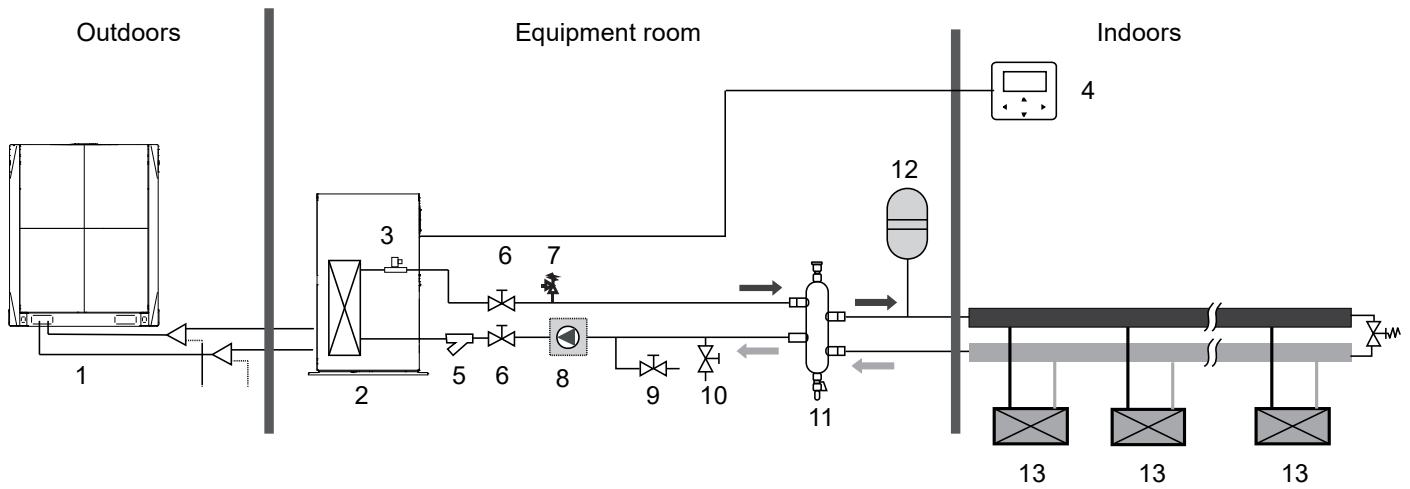

1	ODU
2	Hydraulic module
3	Water flow switch
4	Wired controller (Accessory)
5	Y-shaped filter (Accessory)
6	Check valve (Provided on site)
7	Safety valve (Accessory)
8	Water pump (Provided on site. For model selection, see page 32.)
9	Drain valve (Provided on site)
10	Water replenishing valve (Provided on site)
11	Water collector (Provided on site)
12	Water expansion tank (Provided on site. For model selection, see page 33.)
13	Terminals. The unit can connect to the floor heating device FHL (25 °C-45 °C), fan coil FCU (45 °C-60 °C), and radiator (60 °C-80 °C), which have different temperature requirements.

Note: *The wired controller is placed indoors. Room temperature is detected by the embedded temperature sensor.

On-site settings of the wired controller:

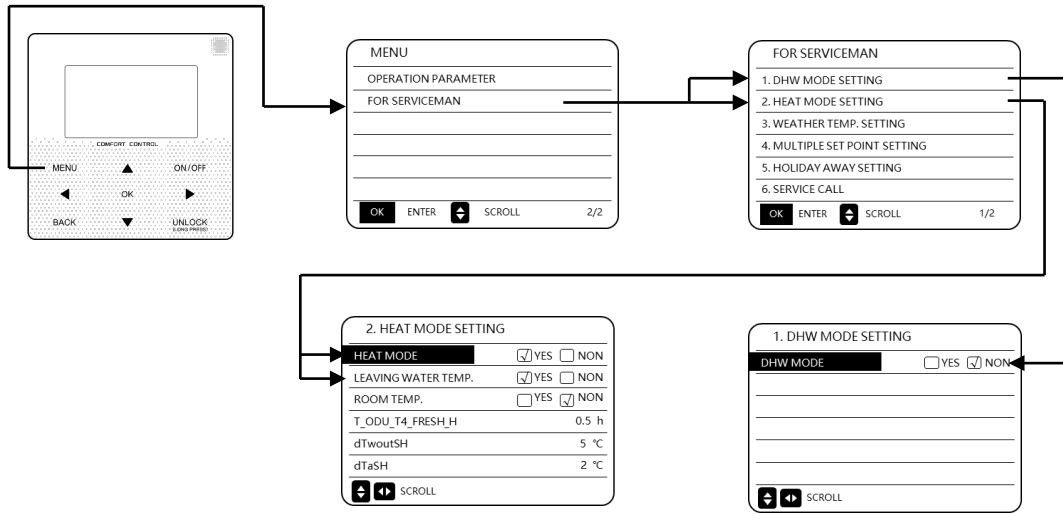

HEAT MODE=YES
Heat mode is valid.
LEAVING WATER TEMP.=YES
Water outlet temperature control is valid.

DHW MODE=NON
DHW mode is invalid.

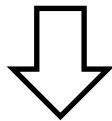

Temperature settings

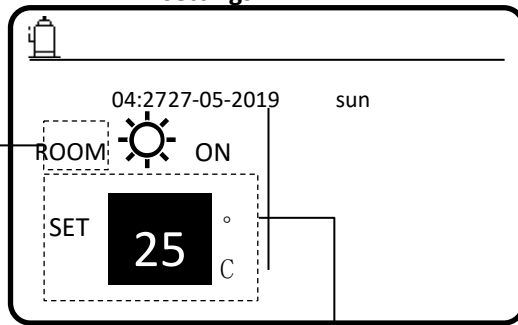

ROOM indicates room temperature control.

Sets the desired room temperature, ranging from 17 C to 30 C.

Only DHW mode is available.

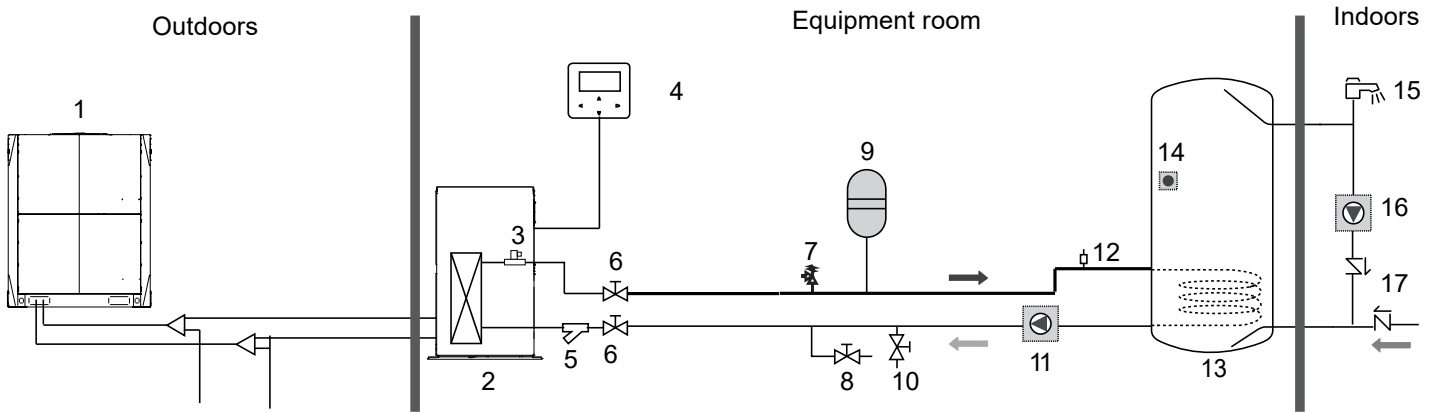

1	ODU
2	Hydraulic module
3	Water flow switch
4	Wired controller (Accessory)
5	Y-shaped filter (Accessory)
6	Check valve (Provided on site)
7	Safety valve (Accessory)
8	Drain valve (Provided on site)
9	Water expansion tank (Provided on site. For model selection, see page 32.)
10	Water replenishing valve (Provided on site)
11	Water pump (Provided on site. For model selection, see page 33.)
12	Discharge valve (Provided on site)
13	Water tank (Provided on site)
14	Temperature sensor of the water tank (Accessory)
15	Tap (Provided on site)
16	Water tank and water pump (Provided on site)
17	One-way valve (Provided on site)

On-site settings of the wired controller:

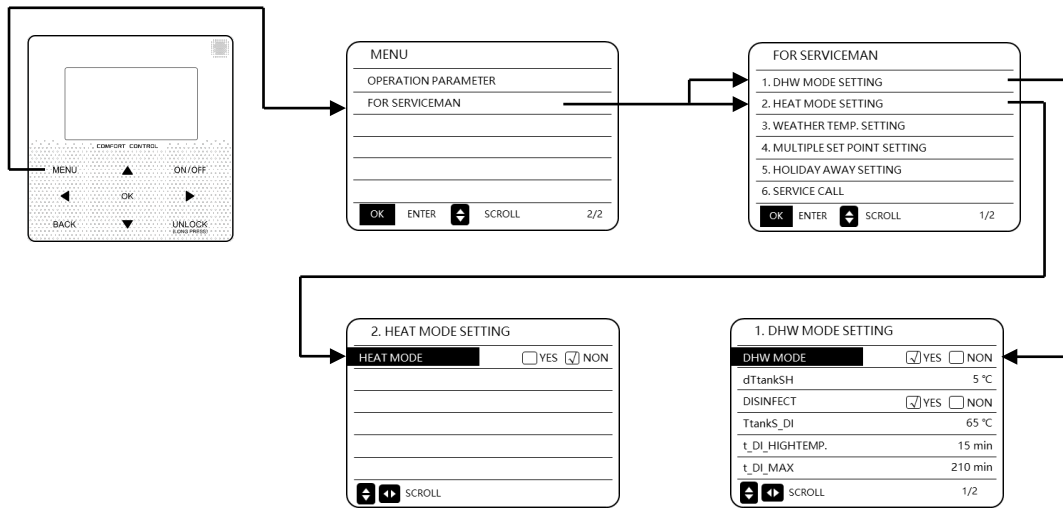

DHW MODE=NON
Heat mode is invalid.

DHW MODE=YES
DHW mode is invalid.

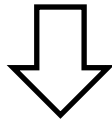

Temperature settings

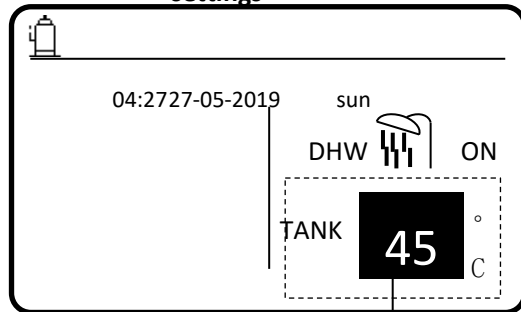

Sets the desired water tank temperature, ranging from 25 C to 80 C.

Heat Mode and DHW Mode

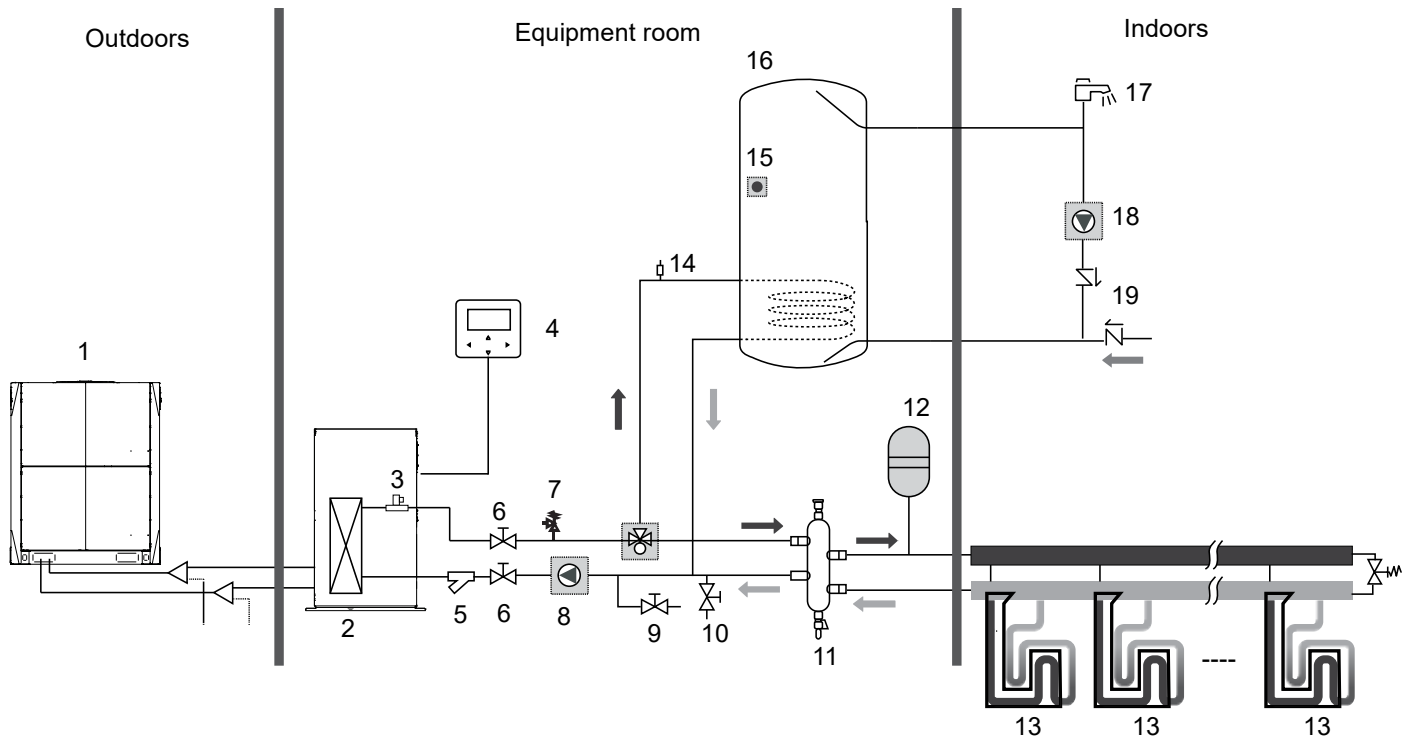

1	ODU
2	Hydraulic module
3	Water flow switch
4	Wired controller (Accessory)
5	Y-shaped filter (Accessory)
6	Check valve (Provided on site)
7	Safety valve (Accessory)
8	Water pump (Provided on site. For model selection, see page 32.)
9	Drain valve (Provided on site)
10	Water replenishing valve (Provided on site)
11	Water collector (Provided on site)
12	Water expansion tank (Provided on site. For model selection, see page 33.)
13	Terminals. The unit can connect to the floor heating device FHL (25 °C-45 °C), fan coil FCU (45 °C-60 °C), and radiator (60 °C-80 °C), which have different temperature requirements.
14	Discharge valve (Provided on site)
15	Water tank (Provided on site)
16	Temperature sensor of the water tank (Accessory)
17	Tap (Provided on site)
18	Water tank and water pump (Provided on site)
19	One-way valve (Provided on site)

Notes for installers and service engineers

Caution

Terminals on the water system side can connect the fan coil (floor heating device/radiator) for heating or a water tank for water heating. Water heating requires the temperature sensor of the water tank provided among accessories to

On-site settings of the wired controller:

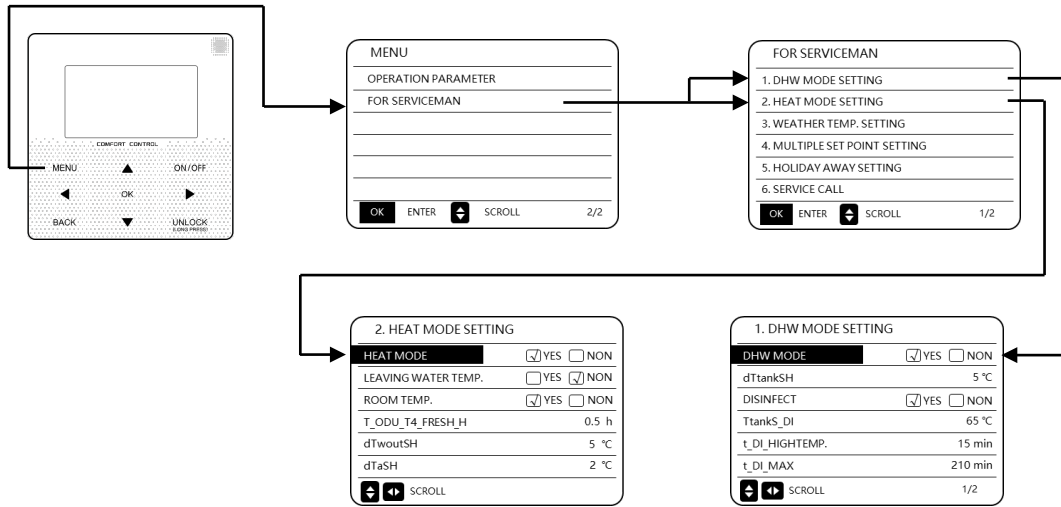

DHW MODE=YES
Heat mode is
invalid.

DHW MODE=YES
DHW mode is
invalid.

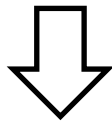

**Temperature
settings**

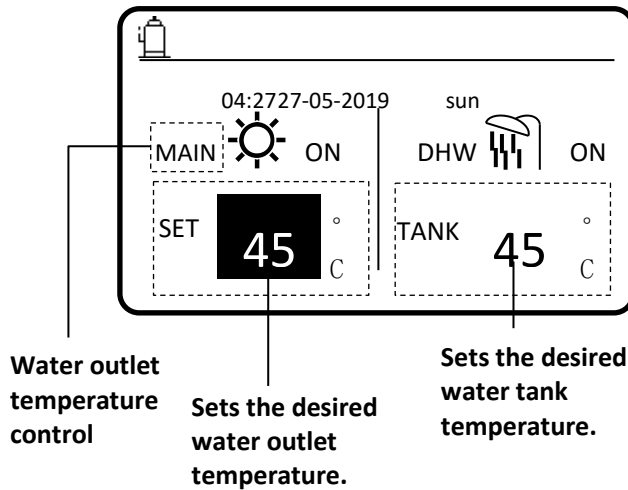

High Temperature Hydro Module



Only heating mode is available and there are multiple set points for heating mode.

Notes for installers and service engineers

Caution

When one hydraulic module is connected to multiple terminals that have different temperature requirements (such as the floor heating device, fan coil unit, and radiator), you need to use the multiple set point function.

High Temperature Hydraulic Module

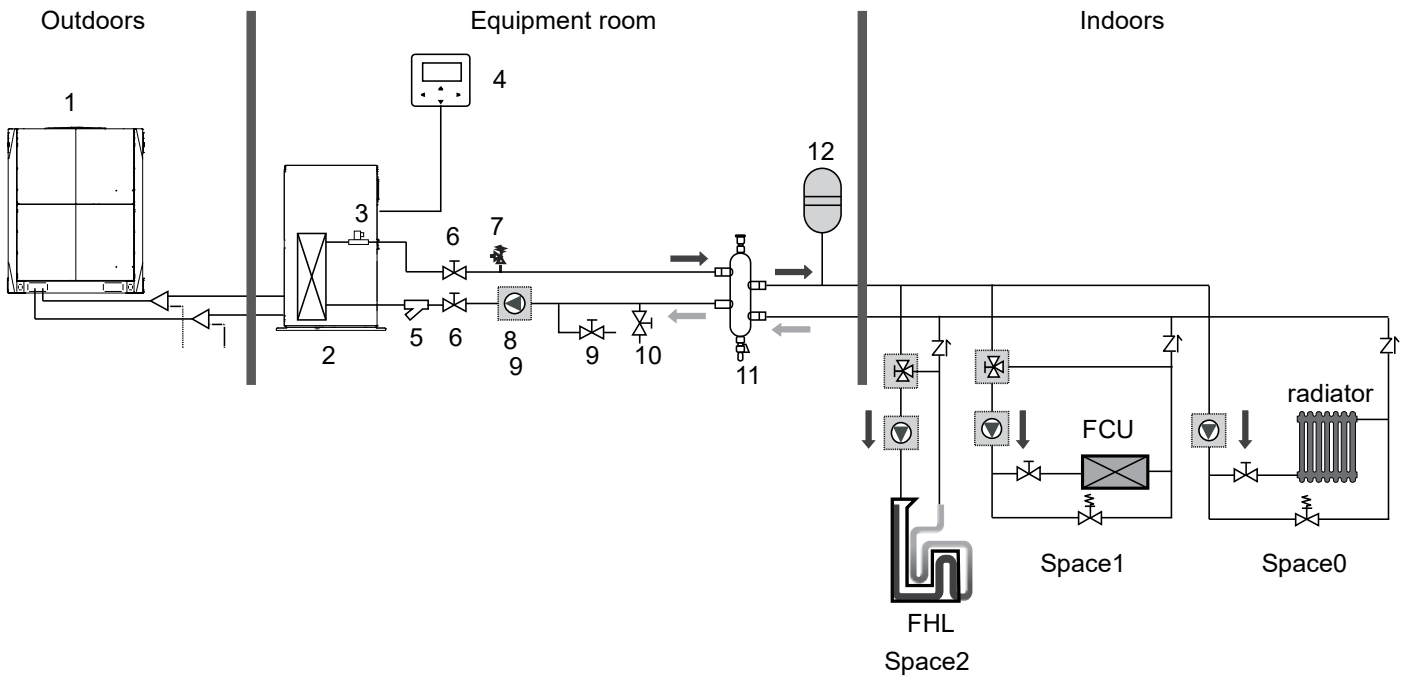

1	ODU
2	Hydraulic module
3	Water flow switch
4	Wired controller (Accessory)
5	Y-shaped filter (Accessory)
6	Check valve (Provided on site)
7	Safety valve (Accessory)
8	Water pump (Provided on site. For model selection, see page 32.)
9	Drain valve (Provided on site)
10	Water replenishing valve (Provided on site)
11	Water collector (Provided on site)
12	Water expansion tank (Provided on site. For model selection, see page 33.)

Enabling the multiple set point of the wired controller:

- When only heating mode is available, the settings are the same as those described above.
- Multiple set point settings are as follows:

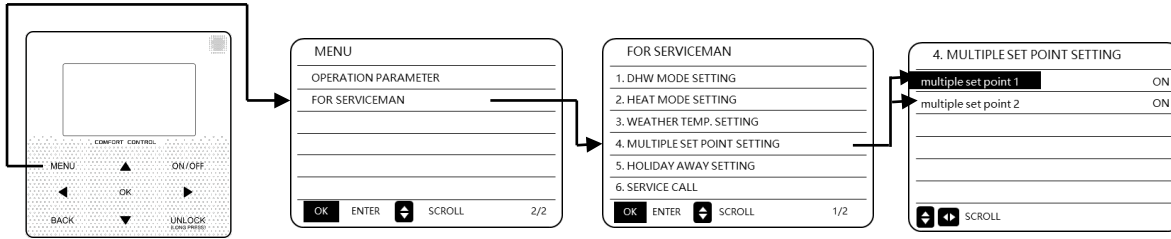

multiple setpoint1=ON: Enable multiple set point 1;
multiple setpoint2=ON: Enable multiple set point 2;

- Temperature settings of multiple set points

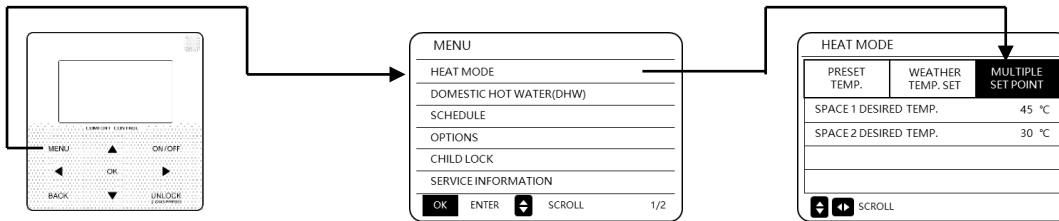

SPACE 1 DESIRED TEMP.: Desired temperature of multiple set point 1;
SPACE 2 DESIRED TEMP.: Desired temperature of multiple set point 2;

No.	Desired temp.	Thermo status			
space 0	a	OFF	ON	OFF	OFF
space 1	b	OFF	ON/OFF	ON	OFF
space 2	c	OFF	ON/OFF	ON/OFF	ON
Resulting desired temp.		OFF	a	b	c

Notes for installers and service engineers

Caution

- space0 can be set on the main interface of the wired controller, while space1 and space2 temperature are set on the HEAT MODE interface
- space0 should be the terminal that requires the highest temperature, while space2 requires the lowest temperature. The temperature required by space1 is between those of space0 and space2. Both space1 and space2 require a temperature reduction device.
- The hydraulic module controls the water outlet temperature according to the highest required temperature in the event of energy demand availability

Group control

Notes for installers and service engineers

Caution

When multiple hydraulic modules heat water for one water tank, the group control function of the hydraulic module should be used.

The group control function is only valid to the DHW mode.

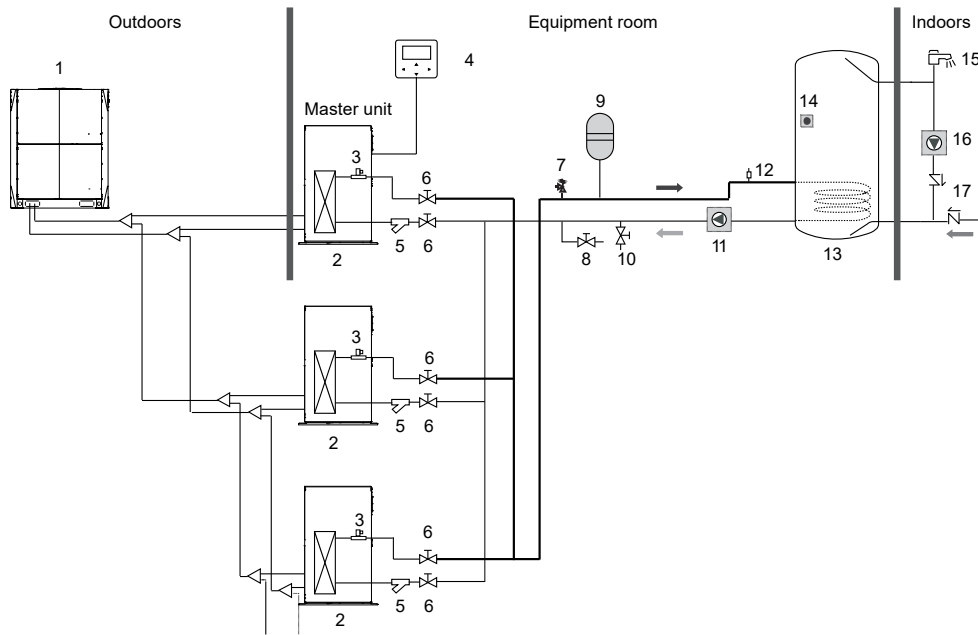

1	ODU
2	Hydraulic module
3	Water flow switch
4	Wired controller (Accessory)
5	Y-shaped filter (Accessory)
6	Check valve (Provided on site)
7	Safety valve (Accessory)
8	Drain valve (Provided on site)
9	Water expansion tank (Provided on site. For model selection, see page 32.)
10	Water replenishing valve (Provided on site)
11	Water pump (Provided on site. For model selection, see page 33.)
12	Discharge valve (Provided on site)
13	Water tank (Provided on site)
14	Temperature sensor of the water tank (Accessory)
15	Tap (Provided on site)
16	Water tank and water pump (Provided on site)
17	One-way valve (Provided on site)

To enable the group control function, you need to use the following steps to set the DIP switch on the main board: for the master hydraulic module, turn digit 11; for the slave hydraulic module, turn digit 10.



Group control function setting:

00 and 01: Group control function is unavailable.

11: Group control function is available. This hydraulic module is a master hydraulic module.

10: Group control function is available. This hydraulic module is a slave hydraulic module.

Notes for installers and service engineers

Caution

- By default, the value is 00, indicating that a controlled group contains only one master unit.
- The master unit must be connected to a wired controller. The wired controller is used to set the desired water tank temperature.
- The slave unit can be connected to or is not connected to a wired controller. The wired controller of the slave unit provides the query function only.
- The pump is controlled by the master unit. The temperature sensor of the water tank is connected to the master unit.
- The wired controller is connected to the master unit is used to set the desired water tank temperature.

Temperature settings for the wired controller of the master unit:

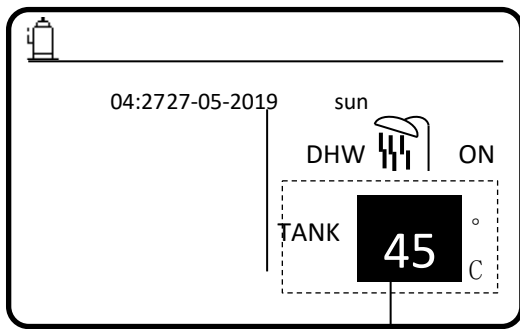

Sets the desired water tank temperature, ranging from 25 C to 80 C.

Notes for installers and service engineers

Caution

- When the water system side of multiple hydraulic modules are connected in parallel and heat water for a single water tank, you need to set master and slave hydraulic modules. The temperature sensor of the water tank is connected to the master hydraulic module and the master hydraulic module sends the water tank temperature to the slave hydraulic module.
- Only the wired controller connected to the master unit can be used to set the desired water tank temperature. The master unit is used to control the switch of the circulating water pump.
- In all the preceding installation scenarios, it is recommended that the automatic air discharge valve should be installed at the highest point of the water system.

9 Pump Model Selection

- The water pump should meet the flow requirements of the hydraulic module. The rated flow of the hydraulic module is 2.4 m³/h, while the allowed flow range is [1.2, 2.9] m³/h.
- The water pump model is based on the calculation of the water resistance and pipe resistance of the hydraulic module. The hydraulic module fluid pressure is as shown in the following figure.

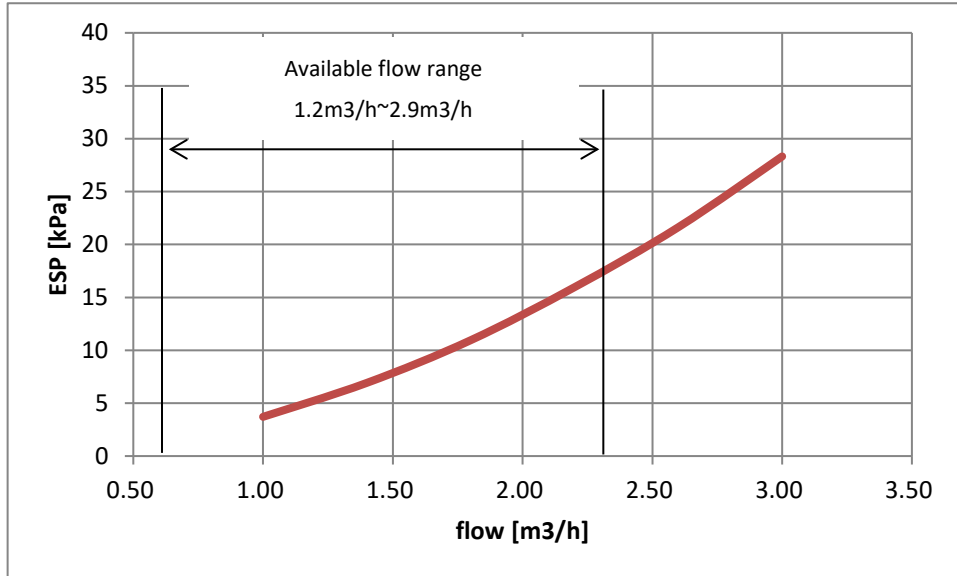

For example:

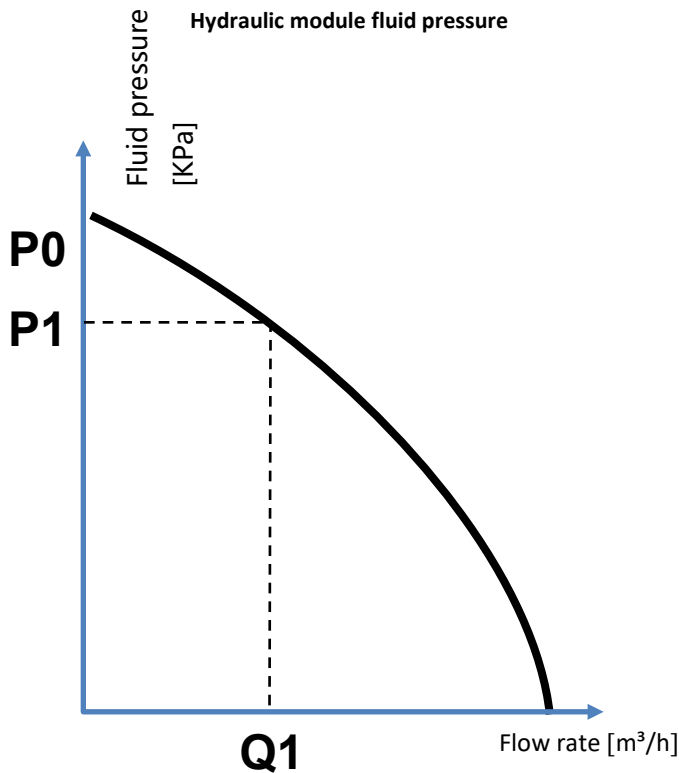

Assume that the performance curve of the selected water pump is as shown in the black figure. When total water resistance in the water system is P₁, the flow rate is Q₁. When Q₁ is within the allowed range of the hydraulic module, the water pump is suitable. When Q₁ is greater than 2.9 m³/h, water pump capacity can be decreased. When Q₁ is less than 1.2 m³/h, the water pump capacity should be increased.

10 Selection of Expansion Tank Volume and Preset Pressure

- Calculating the preset pressure of the expansion tank

$$Pg = \frac{H}{10} + 0.3 \text{ bar}$$

H—The highest point of the water system is higher than the hydraulic module.

If Pg is less than the initially preset pressure of the expansion tank, you do not need to adjust the preset pressure of the expansion tank. In general, the initially preset pressure of the expansion tank is 1.5 bar.

- Calculating the minimum volume of the expansion tank

$$V = 0.0693 * V_{\text{water}} / (2.5 - Pg)$$

V_{water}—Total water volume of the water system

Example 1: Total water volume of the water system of a project is 200 L. The highest point of the water system is 12 m higher than the hydraulic module. Calculate the preset pressure and volume of the expansion tank.

Answer: The preset pressure of the expansion tank is $12 / 10 + 0.3 = 1.5$ bar. The required minimum volume of the expansion tank is $V = 0.0693 * 200 / (2.5 - 1.5) = 13.86$ L.

Example 2: Total water volume of the water system of a project is 72 L. The highest point of the water system is 0 m higher than the hydraulic module. Calculate the preset pressure and volume of the expansion tank.

Answer: The preset pressure of the expansion tank $Pg = 0 / 10 + 0.3 = 0.3$ bar, which is 1.5 bar less than the initially preset pressure of the expansion tank. The required minimum volume of the expansion tank is $V = 0.0693 * 72 / (2.5 - 1.5) = 4.98$ L.

11 Final Check and Test Run

11.1 Final Check

Before closing the switch of the unit, please read the following information:

- When you complete installation of the unit and have performed all the necessary settings, ensure that all the metal plates are closed. This can protect you from electrical parts and high-temperature parts inside the unit.
- The electric control box cover plate can only be opened by an electrician who is certified for maintenance.
- Discharge air in the system.

11.2 Test Run

Test run is described on the installation manual of the ODU. This is an automatic test run, which will last for more than 1 hour.

12 Piping Design

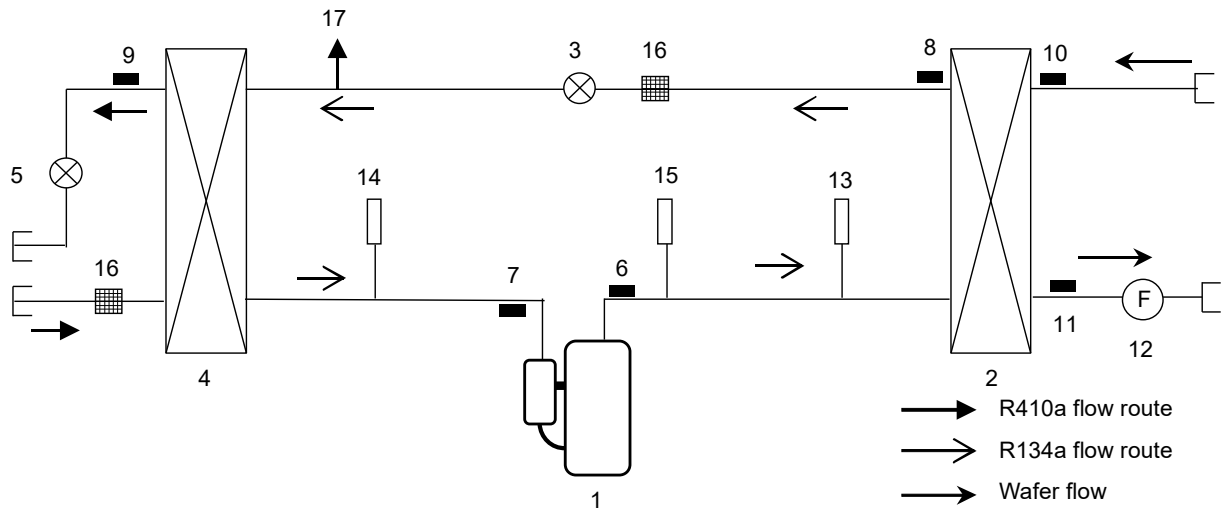

High Temperature Hydraulic Module

NO.	Description	
1	Compressor	/
2	R134a to water Plate heat exchanger	/
3	Electronic expansion valve 1	EEV1
4	R410a to R134a Plate heat exchanger	/
5	Electronic expansion valve 2	EEV2
6	Discharge pipe temperature sensor	T7C
7	Suction pipe temperature sensor	T7
8	R134a circle liquid pipe temperature sensor	T3
9	R410a circle liquid pipe temperature sensor	T2A
10	Water inlet temperature sensor	Twin
11	Water outlet temperature sensor	Twout
12	Flow switch	FS
13	High pressure sensor	H-YL
14	Low pressure sensor	L-YL
15	High pressure switch	H-Pro
16	strainer	/
17	Service pot	/

Key components:

1. Compressor: Drive R134a coolant flow
2. R134a to water Plate heat exchanger :
3. Electronic expansion valve 1: Control R134a refrigerant circulation flow
4. R410a to R134a Plate heat exchanger : Heat transfer between R410a and R134a refrigerants
5. Electronic expansion valve 2: Control the R410a coolant flow of the hydraulic module

13 Wiring Diagram

Figure 9.1: Power and communication wiring

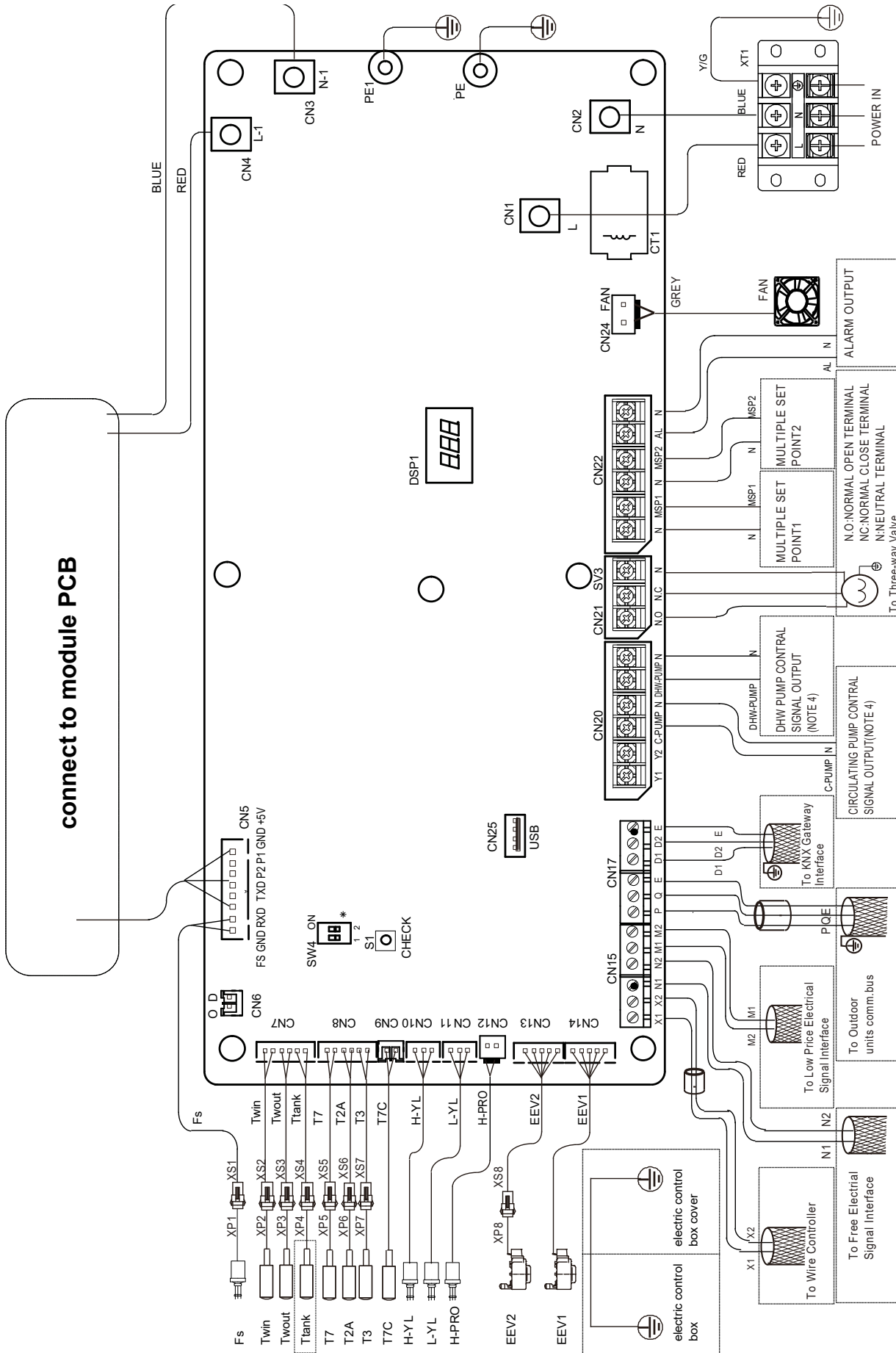

14 Sound Levels

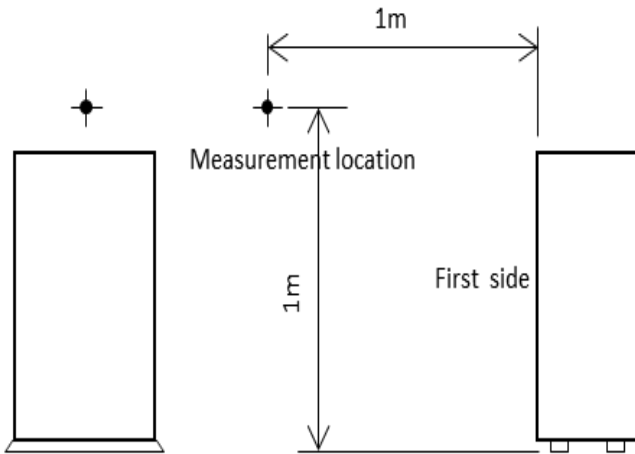

Notes:





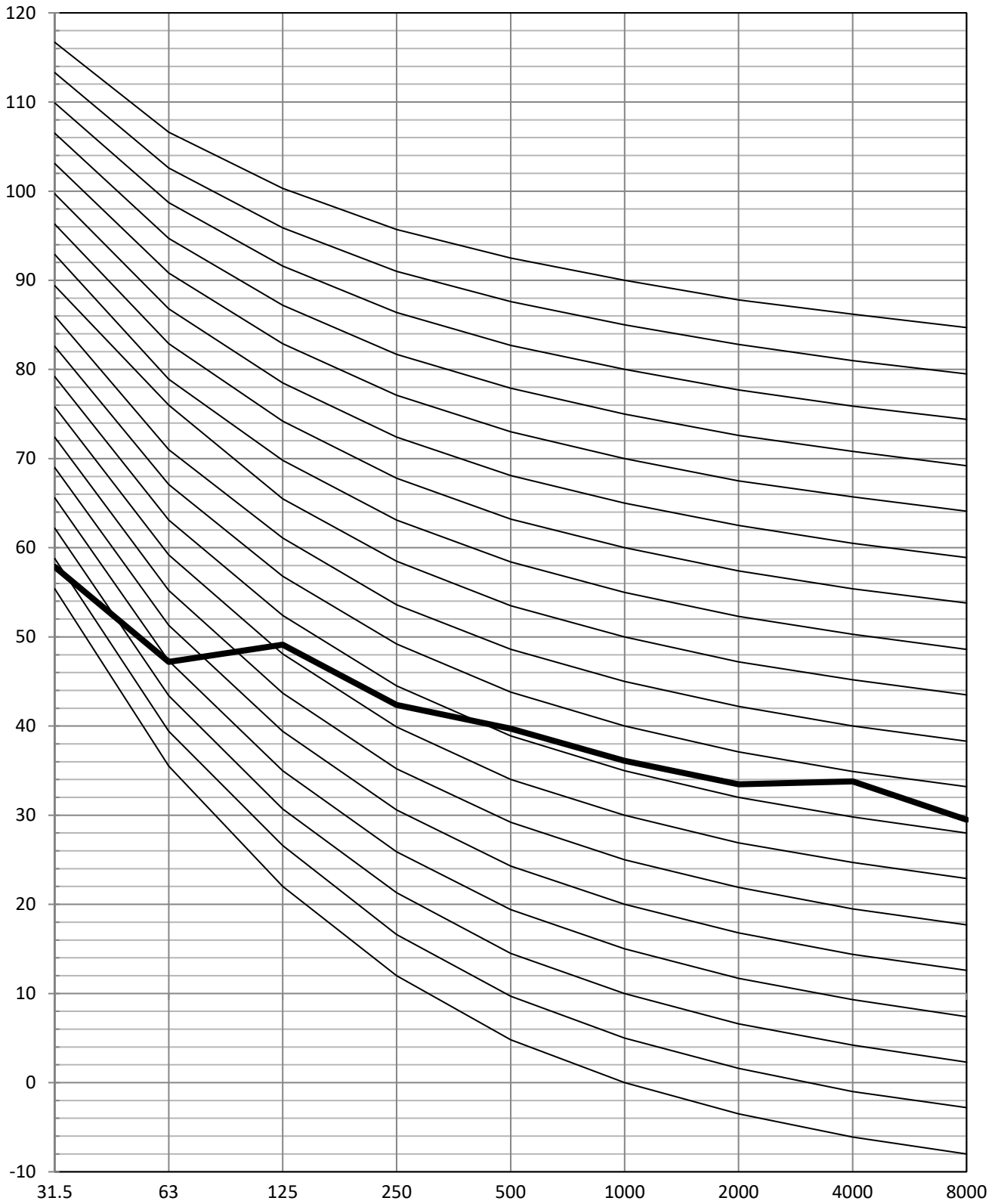

- Sound measured at 1.0m away from the center of the unit.
- Data is valid at free field condition
- Data is valid at nominal operating condition
- Sound level will vary depending on a range of factors such as the construction (acoustic absorption coefficient) of particular room in which the equipment is installed.
- Condition: rated heating condition
 Inlet water Temp. : 40°C
 Outlet water Temp. : 45°C
 Water flow rate : 2.4 m³/h
 Outdoor Temp. : 7 °C/6°C (DB/WB)

Sound pressure level	Nom.	dB (A)	43
Sound Power Level	Nom.	dB (A)	54

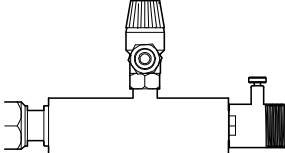

15 Accessories

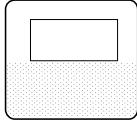
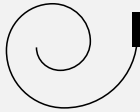
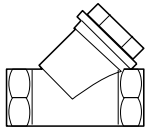
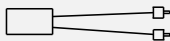
High Temperature Hydraulic Module

Installation Manual	1		—————
User Manual	1		—————
Connecting pipe assembly (Including safety valve)	1		Connected to the water-outlet pipe side
Water discharge hose	1		Connected to the outlet of the drainage pan
Wired controller	1		To control the unit
Water temperature sensor	1		For detecting water tank temperature
Y-shaped filter	1		Connected to the water-inlet pipe side
Magnetic ring	2		—————
Cable tie	6		Fixing the wire and magnetic ring