



Product Data

Symbio™ 210 Programmable VAV Controller

Data Sheet

SAFETY WARNING

Only qualified personnel should install and service the equipment. The installation, starting up, and servicing of heating, ventilating, and air-conditioning equipment can be hazardous and requires specific knowledge and training. Improperly installed, adjusted or altered equipment by an unqualified person could result in death or serious injury. When working on the equipment, observe all precautions in the literature and on the tags, stickers, and labels that are attached to the equipment.

October 2023

BAS-PRD043E-EN

TRANE
TECHNOLOGIES



Trademarks

All trademarks referenced in this document are the trademarks of their respective owners.

Overview

The Symbio™ 210 is optimized for VAV applications and can be factory or field-installed.

VAV applications include:

- Space temperature control
- Flow tracking
- Ventilation flow control

Ordering Numbers

Ordering Number	Description
BMSY210AAA0100011	Symbio™ 210 MS/TP Programmable VAV Controller with no actuator
BMSY210AAA0T00011	Symbio 210 MS/TP Programmable VAV Controller with Trane actuator
BMSY210AAA0B00011	Symbio 210 MS/TP Programmable VAV Controller with Belimo actuator
BMSY210ACA0T00011	Symbio 210 MS/TP Programmable Bypass Controller with Trane actuator
BMSY210ACA0T10011	Symbio 210 MS/TP Programmable Bypass Controller with Trane actuator and duct temperature sensor
BMSY210VTA0T01011	Symbio 210 MS/TP Programmable Zone Damper Controller with Trane actuator and no pressure sensor
BMSY210VTA0101011	Symbio 210 MS/TP Programmable Zone Damper Controller with no actuator and no pressure sensor
BMSY210AAA0T00111	Symbio 210e IP Programmable VAV Controller with Trane actuator
BMSY210AAA0B00111	Symbio 210e IP Programmable VAV Controller with Belimo actuator
BMSY210AAA0100111	Symbio 210e IP Programmable VAV Controller with no actuator
501897940100	VAV controls metal enclosure
WIR06493	Actuator Harness for Symbio 210

Features and Benefits

Features	Benefits
BACnet MS/TP	An open standard building automation communications protocol, which enables connections to other BAS systems and controllers. On identified controllers, BACnet MS/TP controllers provide BACnet communications over RS485 twisted pair, an open standard building automation communications protocol that enables connections to other BAS systems and controllers.
BACnet IP	On identified controllers, BACnet IP controllers provide BACnet communications over Internet Protocol via Local Area Networks (LAN), an open standard building automation communication protocol that enables connections to other BAS systems and controllers.
Configurable and fully programmable	<ul style="list-style-type: none"> • VAV programs available through quick configuration for lowest setup time. • Programmable for flexibility to meet unique sequence or hardware needs.
Total of 14 built-in I/O points	Meets the needs of most VAV applications with extra built-in I/Os available to network, or additional programming on controller.
Expandable to 22 points	Flexibility to meet additional equipment needs.

Controller Specifications and Enclosure Location

Storage	
Temperature:	-67°F to 203°F (-55°C to 95°C)
Humidity:	5% to 95% (non-condensing)

Operating	
Temperature:	-40°F to 122°F (-40°C to 50°C)
Humidity:	5% to 95% (non-condensing)
Power:	20-4-27.6 Vac, (24 Vac ±15% nominal, 50-60 Hz, 10.5 VA plus 1 VA per 20mA of 24 VDC load plus 12 VA maximum per binary load
Environmental Rating (Enclosure):	NEMA 1
Pollution:	U.L. 840: Degree 2
Agency Compliance	
<ul style="list-style-type: none"> • UL916 PAZX- Open Energy Management Equipment • UL94-5V Flammability • CE Marked • FCC Part 15, Subpart B, Class B Limit • AS/NZS CISPR 32:2015 • VCCI-CSPR 32:2016 • CAN ICES-003(B)/NMB-003(B) • Communications BACnet® MS/TP, BACnet IP, or BACnet Zigbee® (Air-Fi®). The Symbio™ 210 is BACnet Testing Laboratory (BTL) certified to revision 15 of the ASHRAE BACnet-135 standard as a Building Controller (BC) profile device. 	

Inputs and Outputs

Analog Inputs 1 through 3 Note: Configuration options when used as spare; 10kΩ thermistor, 0 to 1kΩ linear setpoint, 200kΩ to 20kΩ linear.	Universal Inputs UI1 and UI2 Note: Configuration options when used as spare; 4-20mA, 0-10V, resistive (see AI specifications), binary (solid state open collector).
<ul style="list-style-type: none"> • AI1: Space temperature; thermistor: 10kΩ @77°F (25°C) range: 32°F to 122°F (0°C to 50°C) • AI2: Space setpoint; potentiometer: 1kΩ from 50 to 90°F (10 to 32.2°C), ***(thumbwheel) functionality supported • AI3: Discharge air temperature: 10kΩ @77°F (25°C) from -40°F to 212°F (-40 to 100°C) 	<ul style="list-style-type: none"> • UI1: Relative Humidity • UI2: CO2
Pressure Input P1 <ul style="list-style-type: none"> • P1: Supply air flow; pressure transducer: From 0 to 5 in. water column (0 to 1240 Pa) 	Binary Input BI1, Dry Contact BI1: Occupancy
Analog Outputs/Binary Inputs AO1/BI2 and AO2/BI3 Note: Configuration options when used as spare; Voltage output is 0 to 10 VDC, 500 ohm min. impedance. Current output is 4 - 20 mA, 500Ω max. impedance. Binary input is dry contact closure.	Binary Outputs 1 through 5 Note: 0.5A Resistive Maximum Rating
<ul style="list-style-type: none"> • AO1/BI2: ECM • AO2/BI3: SCR Heat/Water Signal Valve 	<ul style="list-style-type: none"> • BO1: Heat stage 3 TRIAC • BO2: Heat stage 2/Water Valve Close TRIAC • BO3: Heat stage 1/Water Valve Open TRIAC • BO4: Air Damper Open TRIAC • BO5: Air Damper Close TRIAC

Figure 1. Symbio 210 dimensions without actuator

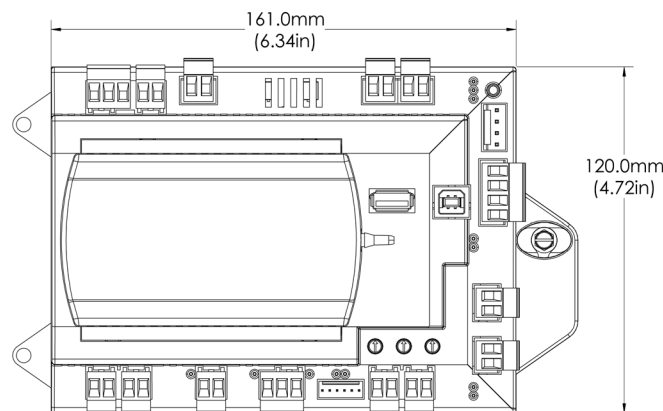

Note: Symbio™ 210e is the same dimensions as the Symbio 210.

Figure 2. Symbio 210 dimensions with actuator

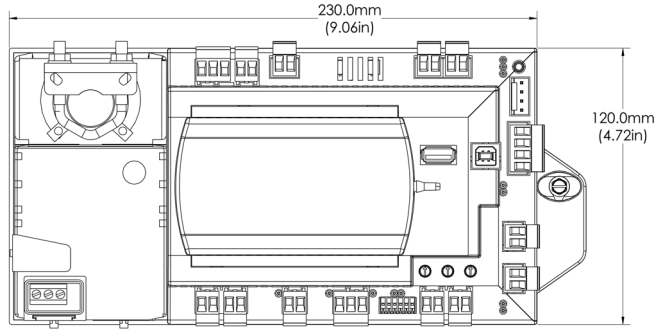

Note: Symbio 210e is the same dimensions as the Symbio 210.

Figure 3. Symbio 210 dimensions (Trane VAV factory version)

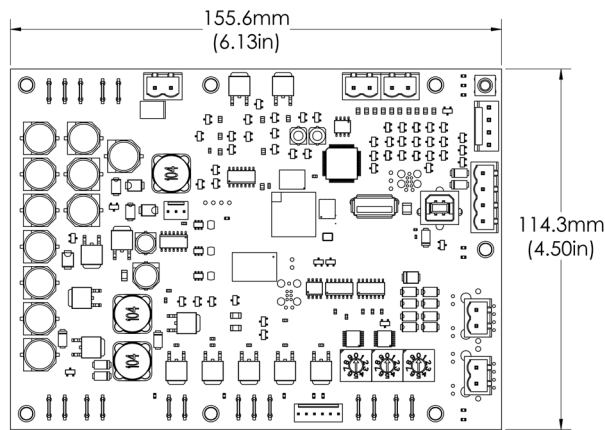

Note: Symbio 210e is the same dimensions as the Symbio 210.

Figure 4. Optional Symbio 210 control box 501897940100 dimensions

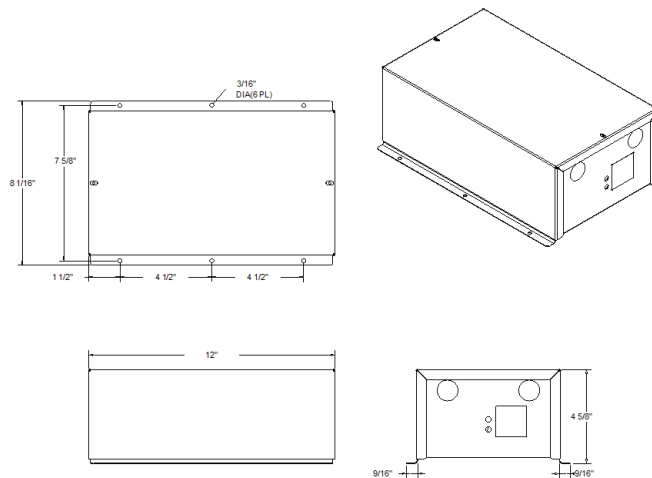

Trane - by Trane Technologies (NYSE: TT), a global climate innovator - creates comfortable, energy efficient indoor environments for commercial and residential applications. For more information, please visit trane.com or tranetechnologies.com.

Trane has a policy of continuous product and product data improvement and reserves the right to change design and specifications without notice. We are committed to using environmentally conscious print practices.