



Quick Reference Guide

**Water Source Heat Pump Axiom™**  
Standard Efficiency 0.5 to 5 Tons  
– GEHG/GEVG



March 2023

**WSHP-PRC029C-EN**  
©2023 Trane



**1 Copyright**

This document and the information in it are the property of Trane, and may not be used or reproduced in whole or in part without written permission. Trane reserves the right to revise this publication at any time, and to make changes to its content without obligation to notify any person of such revision or change.

**Trademarks**

All trademarks referenced in this document are the trademarks of their respective owners.

**Revision History**

- Updated GEHG006-0024 and 030-060 models general data tables.
- Updated ANSI/AHRI/ASHRAE/ISO13256-1 WLHP, GWHP and GLHP performance - 0.5 to 5 tons table.
- Updated Clearances GEHG 0.5 to 5 tons.

**Table 1. List of options**

Factory Installed Options	Field Installed Options
1-inch or 2-inch Ducted Filter Rack	2-inch or 4-inch Ducted Filter Rack
Air-Fi® Wireless Communications	Ducted Panel
Deluxe 24V, UC400B Controls	Hose Kits (or ship separate hoses and valves)
Factory-mounted Isolation Valve	Low, Medium and High Electric Heat
Hot Gas Reheat	Pump Module
Matte or Foil Face Insulation	Pump Module Hose Kit
MERV 8 or 13 Filters	Thermostats or Zone Sensors
Polymer or Stainless Steel IAQ Drain Pan	Waterside Economizer
Recessed Unit Mounted Disconnect Switch	
Standard or Deluxe Sound Package	

**2**

**Table 2. General data - models GEHG006-024**

Model GEHG	006	009	012	015	018	024
Unit size width x depth x height (in.)	23 x 41 x 15.75	23 x 41 x 15.75	23 x 41 x 15.75	25.5 x 46 x 17.75	25.5 x 46 x 17.75	25.5 x 49 x 18.75
Compressor type	Rotary	Rotary	Rotary	Rotary	Rotary	Scroll
Net weight (lbs.)	165	165	165	173	173	269
Ship weight (lbs.)	255	255	255	297	297	393
Filter size nominal (in.)	14 x 16	14 x 16	14 x 16	16 x 19	16 x 19	17 x 20
Water in/out size (FPT)	0.5	0.5	0.5	0.5	0.5	0.75
Condensate size (NPTI)	0.75	0.75	0.75	0.75	0.75	0.75
Blower wheel Size (in.)	9 x 6	9 x 6	9 x 6	9 x 8	9 x 8	10 x 8

**Table 3. General data - models GEHG030-060**

Model GEHG	030	036	042	048	060
Unit size width x depth x height (in.)	25.5 x 49 x 18.75	25.5 x 55 x 19.75	25.5 x 55 x 19.75	28 x 68 x 21.75	28 x 68 x 21.75
Compressor type	Scroll	Scroll	Scroll	Scroll	Scroll
Net weight (lbs.)	269	313	313	381	394
Ship weight (lbs.)	393	437	437	526	539
Filter size nominal (in.)	17 x 20	18 x 23	18 x 23	20 x 30	20 x 30
Water in/out size (FPT)	0.75	0.75	0.75	1.00	1.00
Condensate size (NPTI)	0.75	0.75	0.75	0.75	0.75
Blower wheel Size (in.)	10 x 8	10 x 9	10 x 9	11 x 11	11 x 11

**Table 4. General data - models GEVG006-024**

Model GEVG	006	009	012	015	018	024
Unit size width x depth x height (in.)	19 x 19 x 30	19 x 19 x 30	19 x 19 x 30	21.5 x 21.5 x 34	21.5 x 21.5 x 34	21.5 x 23 x 36
Compressor type	Rotary	Rotary	Rotary	Rotary	Rotary	Scroll
Net weight (lbs.)	149	149	149	155	157	210
Ship weight (lbs.)	201	201	201	210	212	268
Filter size nominal (in.)	14 x 16	14 x 16	14 x 16	16 x 19	16 x 19	16 x 19

**3**

**Table 4. General data - models GEVG006-024 (continued)**

Model GEVG	006	009	012	015	018	024
Water in/out size (FPT)	0.5	0.5	0.5	0.5	0.5	0.75
Condensate size (NPTI)	0.75	0.75	0.75	0.75	0.75	0.75
Blower wheel Size (in.)	9 x 6	9 x 6	9 x 6	9 x 8	9 x 8	10 x 8

**Table 5. General data - models GEVG030-060**

Model GEVG	030	036	042	048	060
Unit size width x depth x height (in.)	21.5 x 23 x 36	21.5 x 26 x 38	21.5 x 26 x 38	24 x 32.5 x 42	24 x 32.5 x 42
Compressor type	Scroll	Scroll	Scroll	Scroll	Scroll
Net weight (lbs.)	214	220	252	280	285
Ship weight (lbs.)	272	280	312	343	348
Filter size nominal (in.)	16 x 19	18 x 23	18 x 23	20 x 30	20 x 30
Water in/out size (FPT)	0.75	0.75	0.75	1.00	1.00
Condensate size (NPTI)	0.75	0.75	0.75	0.75	0.75
Blower wheel Size (in.)	10 x 8	10 x 9	10 x 9	11 x 11	11 x 11

**Table 6. ANSI/AHRI/ASHRAE/ISO13256-1 WLHP, GWHP and GLHP performance - 0.5 to 5 Tons**

Model	Rated GPM	Rated CFM	Water Loop Heat Pump				Ground Water Heat Pump				Ground Loop Heat Pump			
			Cooling 86°F		Heating 68°F		Cooling 59°F		Heating 50°F		Full Cool 77°F		Full Heat 32°F	
			Capacity Btuh	EER	Capacity Btuh	COP	Capacity Btuh	EER	Capacity Btuh	COP	Capacity Btuh	EER	Capacity Btuh	COP
GEH/VG006	1.50	190	7,000	13.70	9,300	4.70	8,100	21.30	7,500	4.10	7,400	16.00	5,600	3.30
GEH/VG009	2.25	285	8,700	15.50	11,200	5.50	9,600	23.80	9,100	4.70	8,900	17.80	6,700	3.70
GEH/VG012	3.00	380	11,400	14.90	15,300	5.30	13,300	24.20	12,400	4.60	12,100	17.60	9,400	3.70
GEH/VG015	3.75	475	14,900	15.3	18,700	5.10	16,600	23.00	15,400	4.30	15,500	17.40	12,300	3.60
GEH/VG018	4.50	570	17,400	15.6	22,200	5.00	19,300	23.50	18,400	4.40	18,100	17.70	14,300	3.60
GEH/VG024	6.00	760	23,900	16.10	31,100	5.30	26,600	24.40	25,300	4.60	24,800	18.50	19,600	3.80

**4**

**Table 6. ANSI/AHRI/ASHRAE/ISO13256-1 WLHP, GWHP and GLHP performance - 0.5 to 5 Tons (continued)**

Model	Rated GPM	Rated CFM	Water Loop Heat Pump				Ground Water Heat Pump				Ground Loop Heat Pump			
			Cooling 86°F		Heating 68°F		Cooling 59°F		Heating 50°F		Full Cool 77°F		Full Heat 32°F	
			Capacity Btuh	EER	Capacity Btuh	COP	Capacity Btuh	EER	Capacity Btuh	COP	Capacity Btuh	EER	Capacity Btuh	COP
GEH/VG030	7.50	950	29,000	15.40	37,900	5.10	32,300	23.00	30,800	4.50	30,200	17.70	23,300	3.70
GEH/VG036	9.00	1140	36,000	15.40	45,100	5.00	39,900	22.60	36,900	4.40	37,300	17.60	28,700	3.60
GEH/VG042	10.50	1330	40,900	14.90	55,600	4.70	45,500	22.00	45,600	4.20	42,600	17.10	35,300	3.50
GEH/VG048	12.00	1520	49,500	15.10	62,600	4.90	55,700	22.80	50,000	4.20	51,800	17.40	37,600	3.30
GEH/VG060	15.00	1900	55,200	14.50	75,400	4.60	61,700	21.30	61,200	4.10	57,300	16.50	47,000	3.50

**Notes:**

1. Rated in accordance with ANSI/AHRI/ASHRAE/ISO13256-1. Certified conditions are 80.6°F DB/66.2°F WB EAT in cooling and 68F DB/59°F WB EAT in heating.
2. Models with capacities greater than 135,000 Btuh are not included in the ANSI/AHRI/ASHRAE/ISO13256-1 water-to-air and brine-to-air heat pump certification program.

**Table 7. Electrical data - ECM motors - GE\* 0.5 to 5 tons**

Model No.	Unit Volts	Blower Motor HP	Minimum Circuit Ampacity	Maximum Overcurrent Protective Device
GEH/GEV006	208-230/60/1	1/3	5/5	15/15
GEH/GEV006	265/60/1	1/3	5	15
GEH/GEV009	208-230/60/1	1/3	6/6	15/15
GEH/GEV009	265/60/1	1/3	5	15
GEH/GEV012	208-230/60/1	1/3	9/9	15/15
GEH/GEV012	265/60/1	1/3	7	15
GEH/GEV015	208-230/60/1	1/3	10/10	15/15
GEH/GEV015	265/60/1	1/3	7	15
GEH/GEV018	208-230/60/1	1/3	12/12	20/20
GEH/GEV018	265/60/1	1/3	10	15
GEH/GEV024	208-230/60/1	1/2	19/19	30/30
GEH/GEV024	265/60/1	1/2	13	20

Table 7. Electrical data - ECM motors - GE\* 0.5 to 5 tons (continued)

Model No.	Unit Volts	Blower Motor HP	Minimum Circuit Ampacity	Maximum Overcurrent Protective Device
GEH/GEV024	208-230/60/3	1/2	11/11	15/15
GEH/GEV024	460/60/3	1/2	6	15
GEH/GEV030	208-230/60/1	3/4	20/20	30/30
GEH/GEV030	208-230/60/3	3/4	13/13	20/20
GEH/GEV030	265/60/1	3/4	16	25
GEH/GEV030	460/60/3	3/4	7	15
GEH/GEV036	208-230/60/1	3/4	24/24	40/40
GEH/GEV036	265/60/1	3/4	20	30
GEH/GEV036	208-230/60/3	3/4	16/16	25/25
GEH/GEV036	460/60/3	3/4	9	15
GEH/GEV042	208-230/60/1	3/4	26/26	40/40
GEH/GEV042	208-230/60/3	3/4	21/21	30/30
GEH/GEV042	460/60/3	1	10	15
GEH/GEV048	208-230/60/1	1	31/31	50/50
GEH/GEV048	208-230/60/3	1	23/23	35/35
GEH/GEV048	460/60/3	1	10	15
GEH/GEV060	208-230/60/1	1	38/38	60/60
GEH/GEV060	208-230/60/3	1	25/25	40/40
GEH/GEV060	460/60/3	1	13	20

Figure 1. Clearances - GEHG 0.5 to 5 tons

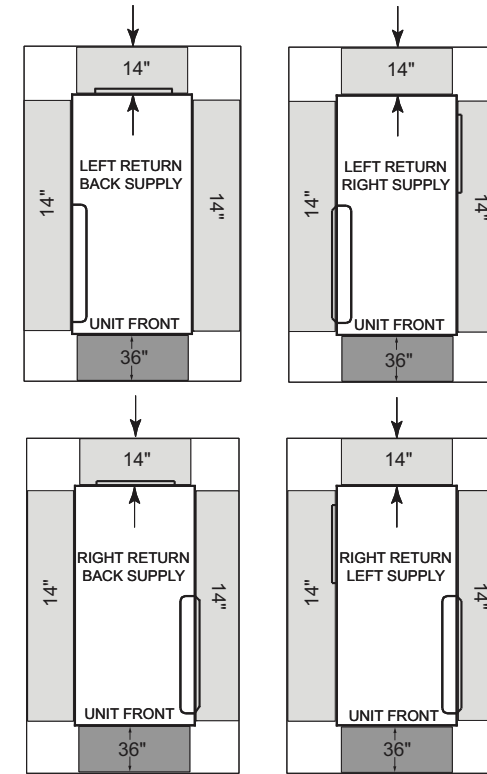

A minimum 14-inch clearance for servicing the unit is required for all 0.5 to 5 tons configurations from other mechanical and electrical equipment (where shown) to enable panel removal from the unit for service/maintenance ability. The optimum clearance required is 20 inches.

Figure 1. Clearances - GEVG 0.5 to 5 tons

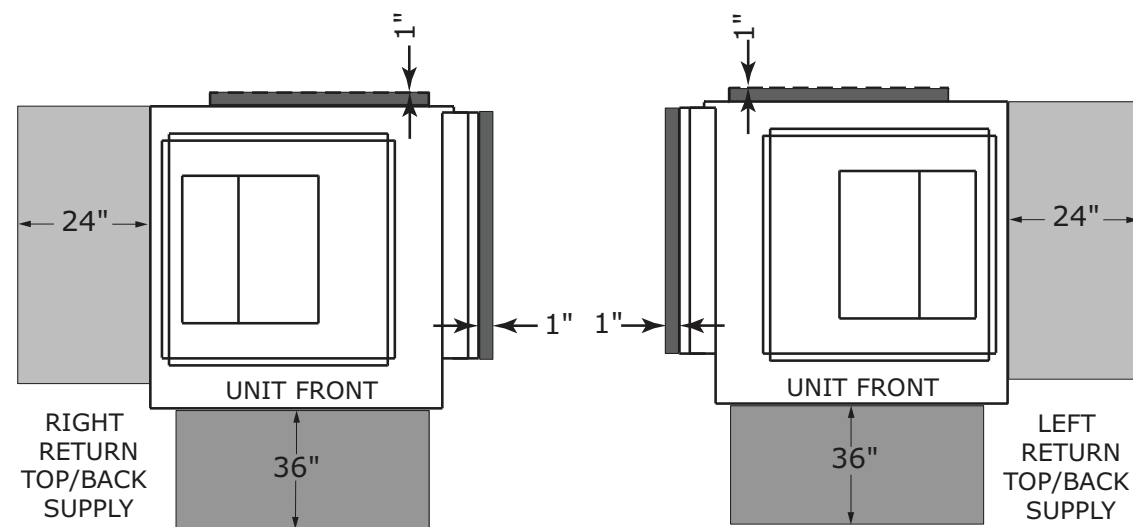

A 24-inch clearance from other mechanical and electrical equipment (where shown) is recommended for most unit configurations. This will enable panel removal from the unit for service/maintenance.

The 24-inch side clearance on GEVG 0.5-5T models is for optimal access only. Side clearance is not a requirement as most components can be accessed from the front of the unit.

A 1-inch minimum clearance between the filter rack and any obstacle is required for units in a free return application to provide proper air flow to the air-to-refrigerant coil. A 12-inch minimum clearance between the filter rack and any obstacle should be provided to properly attached ductwork.

The 1-inch dimension shown in the back of the unit represents the supply duct collar for the back supply option. This clearance is needed to clear these flanges.

Trane - by Trane Technologies (NYSE: TT), a global climate innovator - creates comfortable, energy efficient indoor environments for commercial and residential applications. For more information, please visit [trane.com](http://trane.com) or [tranetechnologies.com](http://tranetechnologies.com).

Trane has a policy of continuous product and product data improvement and reserves the right to change design and specifications without notice. We are committed to using environmentally conscious print practices.