



TRANE®

Downflow/Horizontal Condensing, Gas-Fired Furnace

XB 90

TDC1B040A9241A, TDC1B060A9361A
TDC1B080A9421A, TDC1C100A9481A
TDC1D120A9601A

**Single-Stage Fan Assisted
Combustion System**

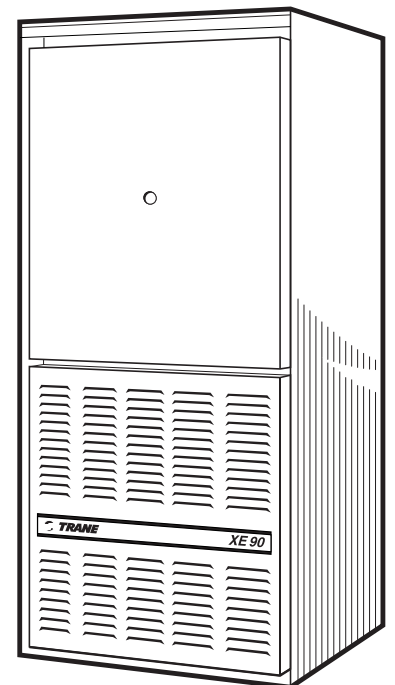
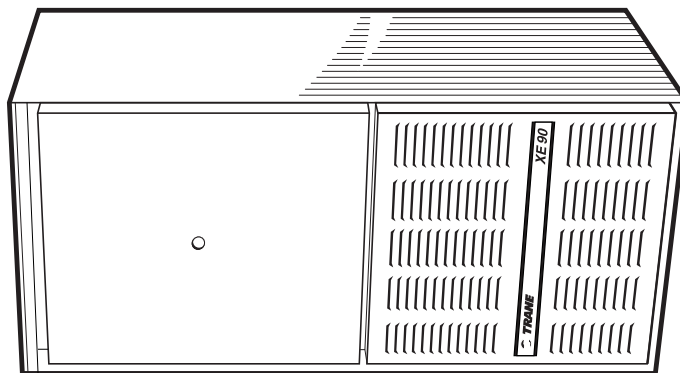

PUB. NO. 22-1670-10



General Features

NATURAL GAS MODELS

Central Heating furnace designs are certified by the American Gas Association for both natural and L.P. gas. Limit setting and rating data were established and approved under standard rating conditions using American National Standards Institute standards.

SAFE OPERATION

The Integrated System Control has solid state devices, which continuously monitor for presence of flame, when the system is in the heating mode of operation. Dual solenoid combination gas valve and regulator provide extra safety.

QUICK HEATING

Durable, cycle tested, heavy gauge **aluminized steel heat exchanger** quickly transfers heat to provide warm conditioned air to the structure. **Low energy power vent blower**, to increase efficiency and provide a positive discharge of gas fumes to the outside.

BURNERS

Multipoint Inshot burners will give years of quiet and efficient service. All models can be converted to **L.P. gas** without changing burners.

INTEGRATED SYSTEM CONTROL

Exclusively designed operational program provides total control of furnace limit sensors, blowers, gas valve, flame control and includes self diagnostics for ease of service. Also contains connection points for E.A.C./humidifier.

AIR DELIVERY

The variable speed, direct drive blower motor, has sufficient airflow for most heating and cooling requirements, will switch from heating to cooling speeds on demand from room thermostat. The blower door safety switch will prevent or terminate furnace operation when the blower door is removed.

STYLING

Heavy gauge steel and “wrap-around” cabinet construction is used in the cabinet with baked-on enamel finish for strength and beauty. The heat exchanger section of the cabinet is completely lined with foil faced fiberglass insulation. This results in quiet and efficient operation due to the excellent acoustical and insulating qualities of fiberglass. Built-in bottom pan and alternate bottom, left or right side return air connection provision.

FEATURES AND GENERAL OPERATION

The XV 80 High Efficiency Gas Furnaces employ a Hot Surface Ignition system, which eliminates the waste of a constant burning pilot. The integrated system control lights the main burners upon a demand for heat from the room thermostat. Complete front service access.

- a. Low energy power venter
- b. Vent proving pressure switch.

Contents

Feature Summary	2
Features and Benefits	4
Standard Equipment	
Optional Equipment	
General Data	6
TDC1B040A9241A	
TDC1B060A9361A	
TDC1B080A9421A	
TDC1C100A9481A	
TDC1D120A9601A	
Performance Data	8
Electrical Data	9
Field Wiring	11
Dimensions	13



Features and Benefits

XB 90 STANDARD EQUIPMENT

- Downflow power supply 115/1/60
- Downflow convertible to horizontal on left side
- **Type 29-4C™** stainless steel secondary heat exchanger
- Inner blower doors
- Direct drive, 4-speed motor
- Silicon Nitride hot surface igniter with adaptive heat up
- Accessory hook-up capability - Hum and EAC
- Quiet induced draft blower
- Blower door safety switch
- Dual solenoid combination gas valve & regulator
- PVC venting - 1 Pipe
- Left/right gas connection
- Selectable cooling fan off delay eliminates need for BAY24X045 time delay relay
- Integrated solid state control with self diagnostics
- 24 volt fuse
- Manual reset burner box limit
- **Optional extended warranties**



Features and Benefits

XB 90 OPTIONAL EQUIPMENT

Thermostat, Electronic, Non-programmable 1 Heating/1 Cool.....	TCONT200AN11AA []
Thermostat, Electronic Programmable 1-Stage Heating/1-Stage Cooling	TCONT800AS11AA []
Thermostat, Heating/Cooling Single Stage (Mounts Vertically).....	BAYSTAT305 []
Thermostat, Electronic Programmable 1-Stage Heating/1-Stage Cooling	BAYSTAT300 []
Propane Conversion Kit.....	BAYLPKT210A []
Electronic Air Filter, "Perfect Fit" High Efficiency (17-1/2" Wide Gas Furnace).....	TFM175A9FR0 []
Electronic Air Filter, "Perfect Fit" High Efficiency (21" Wide Gas Furnace).....	TFM210A9FR0 []
Electronic Air Filter, "Perfect Fit" High Efficiency (24-1/2" Wide Gas Furnace).....	TFM245A9FR0 []
Electronic Air Filter, "Perfect Fit" Standard Efficiency (17-1/2" Wide Gas Furnace).....	TFP175A9FR0 []
Electronic Air Filter, "Perfect Fit" Standard Efficiency (21" Wide Gas Furnace).....	TFP210A9FR0 []
Electronic Air Filter, "Perfect Fit" Standard Efficiency (24-1/2" Wide Gas Furnace).....	TFP245A9FR0 []
Coil Enclosure (17-1/2" Wide Cabinets)	BAYCLE17A1722A []
Coil Enclosure (21" Wide Cabinets)	BAYCLE21A2130A []
Coil Enclosure (24-1/2" Wide Cabinets)	BAYCLE24A2430A []
Side Filter Rack	BAYFLTR200 []
High Altitude Switch.....	BAYHALT239 []



General Data

PRODUCT SPECIFICATIONS ①

MODEL	TDC1B040A9241A	TDC1B060A9361A	TDC1B080A9421A
TYPE	Downflow / Horizontal	Downflow / Horizontal	Downflow / Horizontal
RATINGS ②			
Input BTUH	40,000	60,000	80,000
Capacity BTUH (ICS) ③	38,000	56,000	74,000
AFUE	92.1	92.1	92.1
Temp. rise (Min.-Max.) °F.	30 - 60	35 - 65	35 - 65
BLOWER DRIVE	DIRECT	DIRECT	DIRECT
Diameter - Width (In.)	10 x 7	10 x 8	11 x 8
No. Used	1	1	1
Speeds (No.)	4	4	4
CFM vs. in. w.g.	See Fan Performance Table	See Fan Performance Table	See Fan Performance Table
Motor HP	1/5	1/3	1/2
R.P.M.	1080	1075	1075
Volts/Ph/Hz	115/1/60	115/1/60	115/1/60
COMBUSTION FAN - Type	Centrifugal	Centrifugal	Centrifugal
Drive - No. Speeds	Direct - 1	Direct - 1	Direct - 1
Motor HP - RPM	1/55 - 3000	1/55 - 3000	1/25 - 3200
Volts/Ph/Hz	115/1/60	115/1/60	115/1/60
FLA	1.0	1.0	1.35
FILTER — Furnished?	No	No	No
Type Recommended	High Velocity	High Velocity	High Velocity
Hi Vel. (No.-Size-Thk.)	2 - 14x20 - 1in.	2 - 14x20 - 1in.	2 - 14x20 - 1in.
VENT — Size (in.)	2 Round	2 Round	2 Round
HEAT EXCHANGER			
Type-Fired	Aluminized Steel - Type I	Aluminized Steel - Type I	Aluminized Steel - Type I
-Unfired			
Gauge (Fired)	20	20	20
ORIFICES — Main			
Nat. Gas. Qty. — Drill Size	2 — 45	3 — 45	4 — 45
L.P. Gas Qty. — Drill Size	2 — 56	3 — 56	4 — 56
GAS VALVE	Redundant - Single Stage	Redundant - Single Stage	Redundant - Single Stage
PILOT SAFETY DEVICE			
Type	Hot Surface Ignition	Hot Surface Ignition	Hot Surface Ignition
BURNERS — Type	Multiport Inshot	Multiport Inshot	Multiport Inshot
Number	2	3	4
POWER CONN. — V/Ph/Hz ④	115/1/60	115/1/60	115/1/60
Ampacity (In Amps)	4.7	9.1	11.4
Max Overcurrent Protection (Amps)	15	15	15
PIPE CONN. SIZE (IN.)	1/2	1/2	1/2
DIMENSIONS	H x W x D	H x W x D	H x W x D
Crated (In.)	41-3/4 x 19-1/2 x 30-1/2	41-3/4 x 19-1/2 x 30-1/2	41-3/4 x 19-1/2 x 30-1/2
WEIGHT			
Shipping (Lbs.)/Net (Lbs)	145 / 135	155 / 145	168 / 158

① Central Furnace heating designs are certified by ETL.

② Ratings shown are for elevations up to 2000 feet. For elevations above 2000 feet; Ratings should be reduced at the rate of 4% for each 1000 feet above sea level.

③ Based on U.S. government standard tests.

④ The above wiring specifications are in accordance with National Electrical Code; however, installations must comply with local codes.



General Data

PRODUCT SPECIFICATIONS ①

MODEL	*DC1C100A9481A	*DC1D120A9601A
TYPE	Downflow / Horizontal	Downflow / Horizontal
RATINGS ②		
Input BTUH	100,000	120,000
Capacity BTUH (ICS) ③	93,000	112,000
AFUE	92.1	92.1
Temp. rise (Min.-Max.) °F.	35 - 65	40 - 70
BLOWER DRIVE	DIRECT	DIRECT
Diameter - Width (In.)	11 x 10	11 x 10
No. Used	1	1
Speeds (No.)	4	4
CFM vs. in. w.g.	See Fan Performance Table	See Fan Performance Table
Motor HP	1/2	1/2
R.P.M.	1075	1075
Volts/Ph/Hz	115/1/60	115/1/60
COMBUSTION FAN - Type	Centrifugal	Centrifugal
Drive - No. Speeds	Direct - 1	Direct - 1
Motor HP - RPM	1/20 - 3450	1/20 - 3450
Volts/Ph/Hz	115/1/60	115/1/60
FLA	0.71	0.71
FILTER — Furnished?	No	No
Type Recommended	High Velocity	High Velocity
Hi Vel. (No.-Size-Thk.)	2 - 16x20 - 1in.	2 - 16x20 - 1in.
VENT — Size (in.)	2 Round	3 Round
HEAT EXCHANGER		
Type-Fired	Aluminized Steel - Type I	Aluminized Steel - Type I
-Unfired		
Gauge (Fired)	20	20
ORIFICES — Main		
Nat. Gas. Qty. — Drill Size	5 — 45	6 — 45
L.P. Gas Qty. — Drill Size	5 — 56	6 — 56
GAS VALVE	Redundant - Single Stage	Redundant - Single Stage
PILOT SAFETY DEVICE		
Type	Hot Surface Ignition	Hot Surface Ignition
BURNERS — Type	Multiport Inshot	Multiport Inshot
Number	5	6
POWER CONN. — V/Ph/Hz ④	115/1/60	115/1/60
Ampacity (In Amps)	13.6	12.9
Max Overcurrent Protection (Amps)	20	20
PIPE CONN. SIZE (IN.)	1/2	1/2
DIMENSIONS	H x W x D	H x W x D
Crated (In.)	41-3/4 x 23 x 30-1/2	41-3/4 x 26-1/2 x 30-1/2
WEIGHT		
Shipping (Lbs.)/Net (Lbs)	185 / 175	206 / 196

① Central Furnace heating designs are certified by ETL.

② Ratings shown are for elevations up to 2000 feet. For elevations above 2000 feet; Ratings should be reduced at the rate of 4% for each 1000 feet above sea level.

③ Based on U.S. government standard tests.

④ The above wiring specifications are in accordance with National Electrical Code; however, installations must comply with local codes.



Performance Data

FURNACE AIRFLOW (CFM) VS. EXTERNAL STATIC PRESSURE (in. w.c.)										
MODEL	SPEED TAP	0.10	0.20	0.30	0.40	0.50	0.60	0.70	0.80	0.90
TDC1B040A9241A	4 - HIGH - Black	998	965	922	870	807	735	653	561	459
	3 - MED.-HIGH - Blue	856	832	797	751	695	628	550	462	363
	2 - MED.-LOW - Yellow	753	728	694	650	596	533	460	378	286
	1 - LOW - Red	647	617	581	538	490	435	375	308	235
TDC1B060A9361A	4 - HIGH - Black	1341	1285	1223	1156	1082	1004	919	829	734
	3 - MED.-HIGH - Blue	1198	1161	1115	1060	996	923	842	751	652
	2 - MED.-LOW - Yellow	1369	1232	1108	998	901	817	747	689	645
	1 - LOW - Red	784	781	767	741	703	654	593	521	437
TDC1B080A9421A	4 - HIGH - Black	1547	1498	1445	1386	1323	1254	1180	1101	1016
	3 - MED.-HIGH - Blue	1487	1436	1382	1325	1265	1202	1137	1069	998
	2 - MED.-LOW - Yellow	1388	1348	1302	1249	1191	1126	1056	979	896
	1 - LOW - Red	1263	1234	1196	1150	1095	1032	960	879	790
TDC1C100A9481A	4 - HIGH - Black	1892	1827	1762	1688	1614	1531	1448	1354	1260
	3 - MED.-HIGH - Blue	1779	1726	1672	1605	1538	1460	1381	1291	1200
	2 - MED.-LOW - Yellow	1630	1587	1544	1485	1426	1362	1297	1208	1119
	1 - LOW - Red	1444	1416	1388	1348	1308	1246	1184	1108	1032
TDC1D120A9601A	4 - HIGH - Black	2213	2138	2062	2001	1939	1863	1786	1706	1625
	3 - MED.-HIGH - Blue	2057	2000	1943	1883	1822	1752	1681	1595	1508
	2 - MED.-LOW - Yellow	1765	1733	1700	1652	1603	1552	1500	1424	1347
	1 - LOW - Red	1468	1452	1435	1409	1382	1336	1290	1225	1159

CFM VS. TEMPERATURE RISE																					
MODEL	Cubic Feet Per Minute (CFM)																				
	600	700	800	900	1000	1100	1200	1300	1400	1500	1600	1700	1800	1900	2000	2100	2200	2300	2400		
TDC1B040A9241A	56	48	42	37	34																
TDC1B060A9361A			63	56	51	46	42	39	36	34											
TDC1B080A9421A					68	61	56	52	48	45	42	40									
TDC1C100A9481A								65	60	56	53	50	47	44	42	40	38	37	35		
TDC1D120A9601A										67	63	59	56	53	51	48	46	44	42		

Electrical Data

SCHEMATIC DIAGRAMS FOR GAS FURNACES

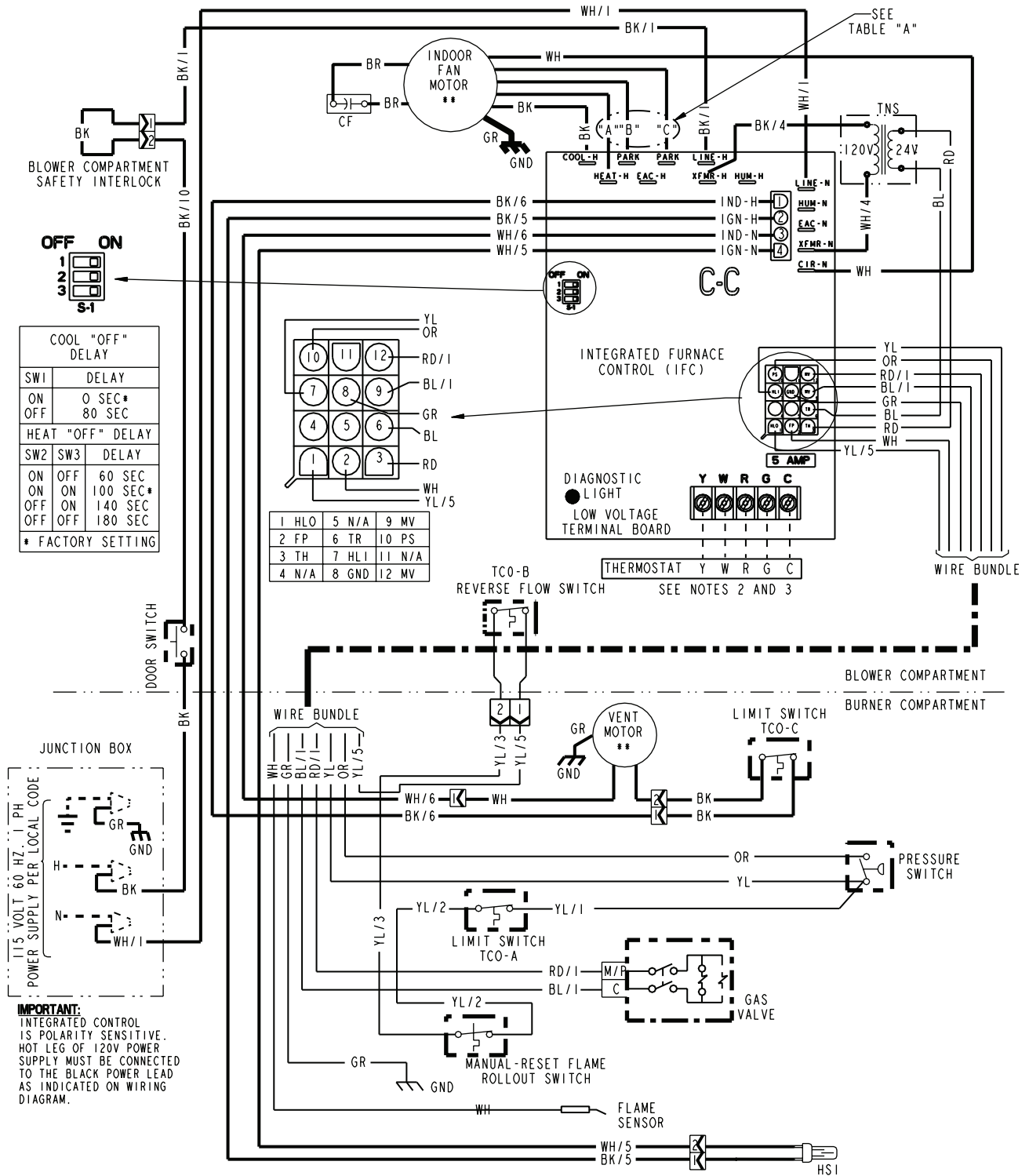

From Dwg. D342798



Electrical Data

SCHEMATIC DIAGRAMS FOR GAS FURNACES

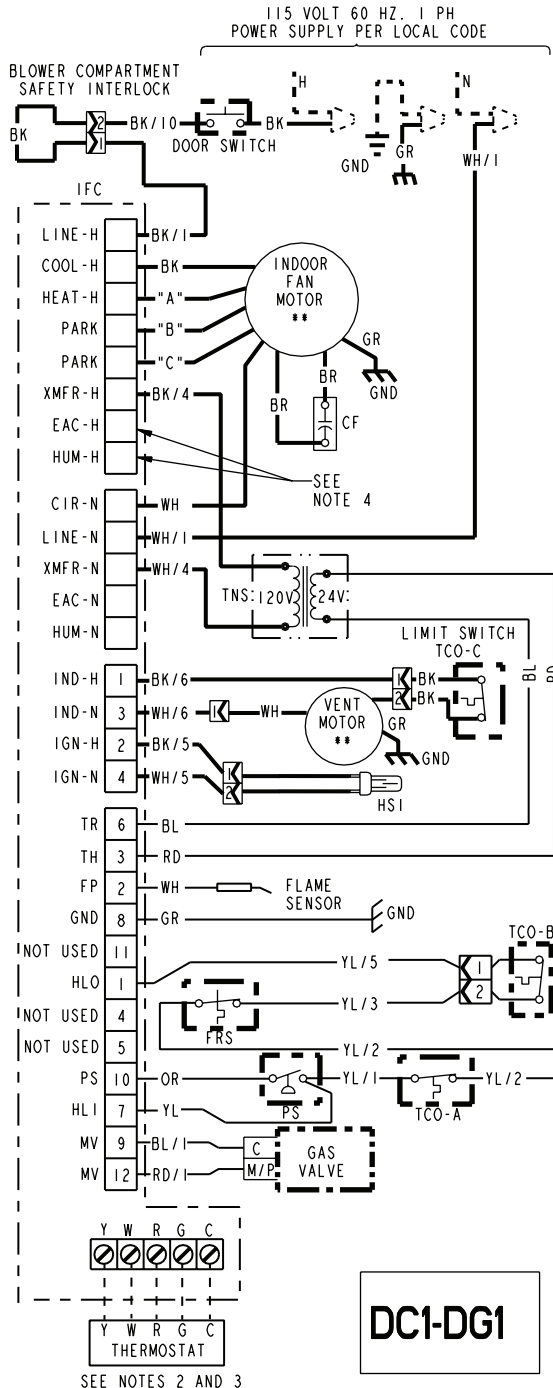

TABLE "A"
SPEED TAPS FOR I.D. FAN MOTOR

MODEL	HEAT "A"	PARK "B"	PARK "C"
#DC1B040A9241A*	YL	RD	BL
#DC1B060A9361A*	YL	RD	BL
#DC1B080A9421A* #DG1B080A9421A*	BL	RD	YL
#DC1C100A9481A*	BL	RD	YL
#DC1D120A9601A*	BL	RD	YL

RD = LOW BL = MED. HIGH
YL = MED. LOW BK = HIGH
- MAY BE "T" or "A"
* - MAY BE A THROUGH Z

WARNING
HAZARDOUS VOLTAGE:
DISCONNECT ALL ELECTRICAL POWER INCLUDING REMOTE DISCONNECTS BEFORE SERVICING.
FAILURE TO DISCONNECT POWER BEFORE SERVICING CAN CAUSE SEVERE PERSONAL INJURY OR DEATH.

CAUTION
USE COPPER CONDUCTORS ONLY!
UNIT TERMINALS ARE NOT DESIGNED TO ACCEPT OTHER TYPES OF CONDUCTORS. FAILURE TO DO SO MAY CAUSE DAMAGE TO THE EQUIPMENT.

INTEGRATED FURNACE CONTROL
REPLACE WITH PART CNT02891 OR CNT 02183 OR EQUIVALENT
INPUT: 25 VAC, 60 HZ.
XFMR SEC. CURRENT: 450 MA.
MV OUTPUT: 1.5 A @ 24 VAC
IND OUTPUT: 2.2 FLA, 3.5 LRA @ 120 VAC
CIRC. BLOWER OUTPUT: 14.5 FLA, 26 LRA @ 120 VAC
HUMIDIFIER & AIR CLEANER
MAX. LOAD: 1.0 A @ 120 VAC
IGNITER OUTPUT: .5 A @ 120 VAC

DIAGNOSTIC CODES

FLASHING SLOW: NORMAL - NO CALL FOR HEAT
FLASHING FAST: NORMAL - CALL FOR HEAT
CONTINUOUS ON: REPLACE IFC
CONTINUOUS OFF: CHECK POWER
2 FLASHES: EXTERNAL LOCKOUT (RETRIES OR RECYCLES EXCEEDED)
3 FLASHES: PRESSURE SWITCH ERROR
4 FLASHES: OPEN LIMIT DEVICE
5 FLASHES: FLAME SENSED WHEN NO FLAME SHOULD BE PRESENT
6 FLASHES: 115 VAC POWER REVERSED POLARITY OR POOR GROUNDING
7 FLASHES: GAS VALVE CIRCUIT ERROR
8 FLASHES: LOW FLAME SENSE SIGNAL

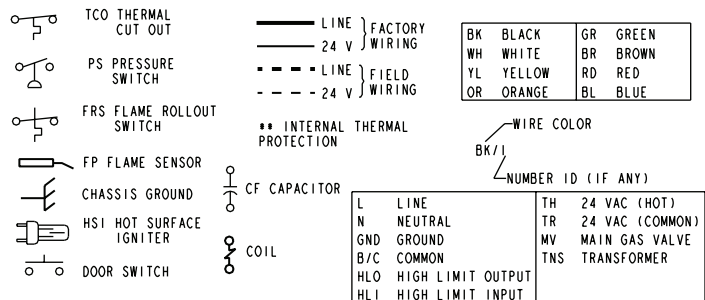

NOTES:

- IF ANY OF THE ORIGINAL WIRING AS SUPPLIED WITH THIS FURNACE MUST BE REPLACED, IT MUST BE WITH WIRE HAVING A TEMPERATURE RATING OF AT LEAST 105 C.
- THERMOSTAT HEAT ANTICIPATOR SETTING: .38 AMPS
- FOR PROPER OPERATION OF COOLING SPEED, "Y" TERMINAL MUST BE CONNECTED TO THE ROOM THERMOSTAT.
- THESE TERMINALS PROVIDE 120V POWER CONNECTIONS FOR ELECTRONIC AIR CLEANER (EAC) AND HUMIDIFIER (HUM). MAX. LOAD: 1.0 AMPS EACH.

Field Wiring

FIELD WIRING DIAGRAM FOR HEATING ONLY

FIELD WIRING DIAGRAM FOR SINGLE STAGE HEATING

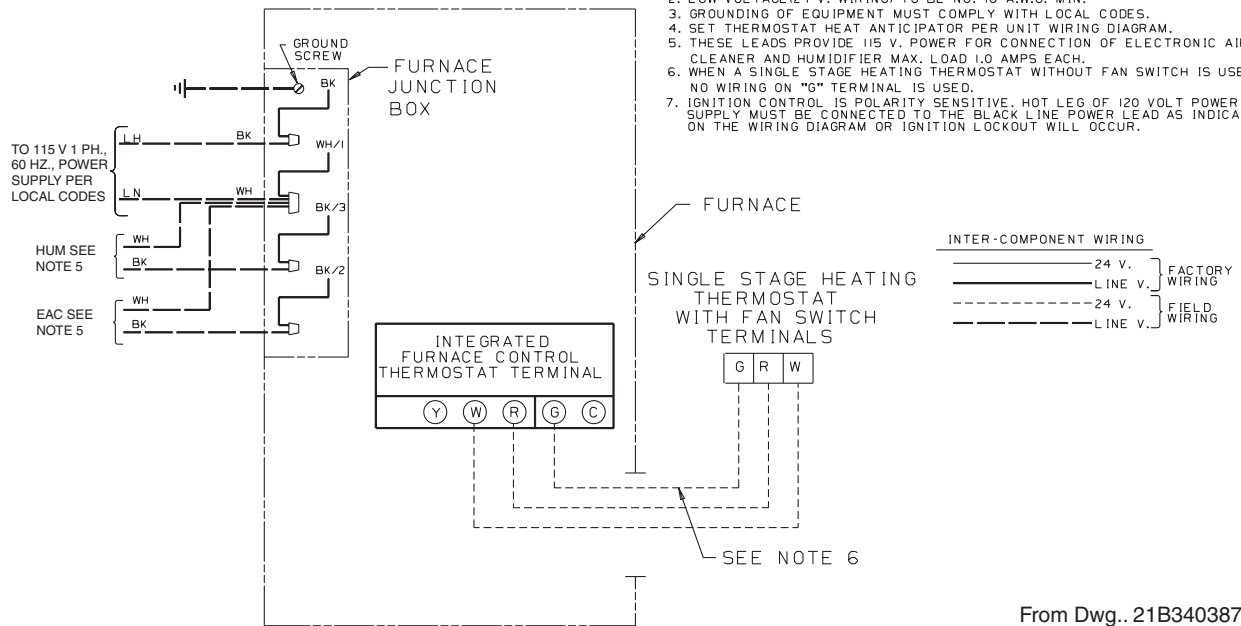

From Dwg.. 21B340387 Rev. 1

FIELD WIRING DIAGRAM FOR SINGLE STAGE HEATING/COOLING (OUTDOOR SECTION WITHOUT TRANSFORMER)

FIELD WIRING DIAGRAM FOR SINGLE STAGE HEATING/COOLING (OUTDOOR SECTION WITHOUT TRANSFORMER)

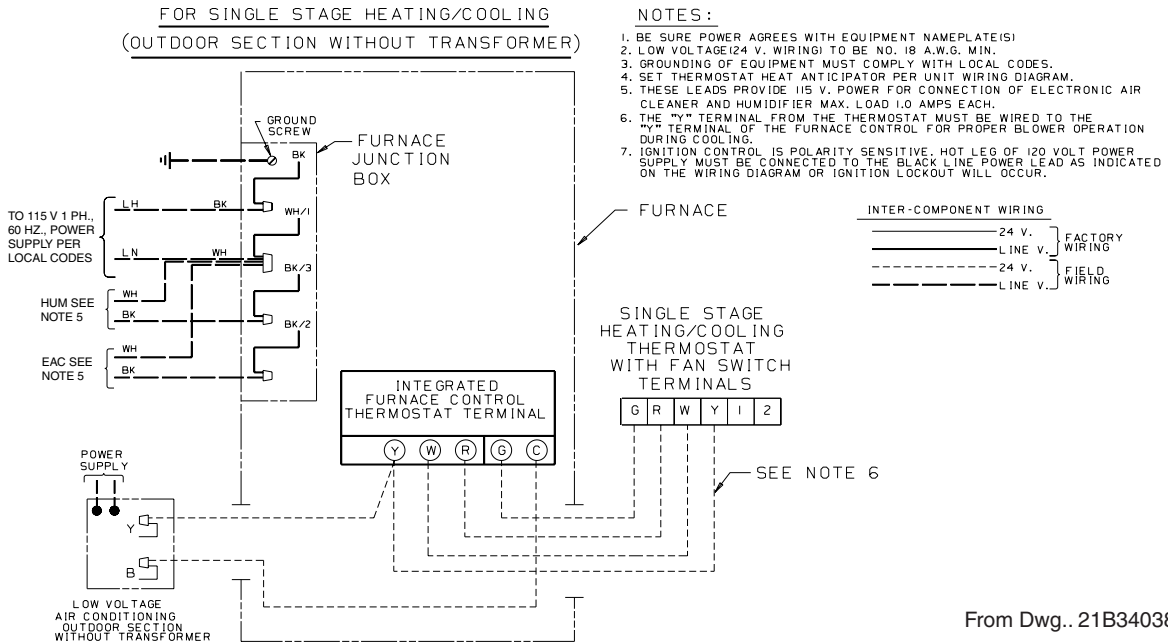

From Dwg.. 21B340388 Rev. 1

Field Wiring

TWINNING CONNECTION DIAGRAM
FOR TWINNING 1 STAGE FURNACES WITH SINGLE WIRE TWINNING FEATURE
1 STAGE HEATING ONLY THERMOSTAT

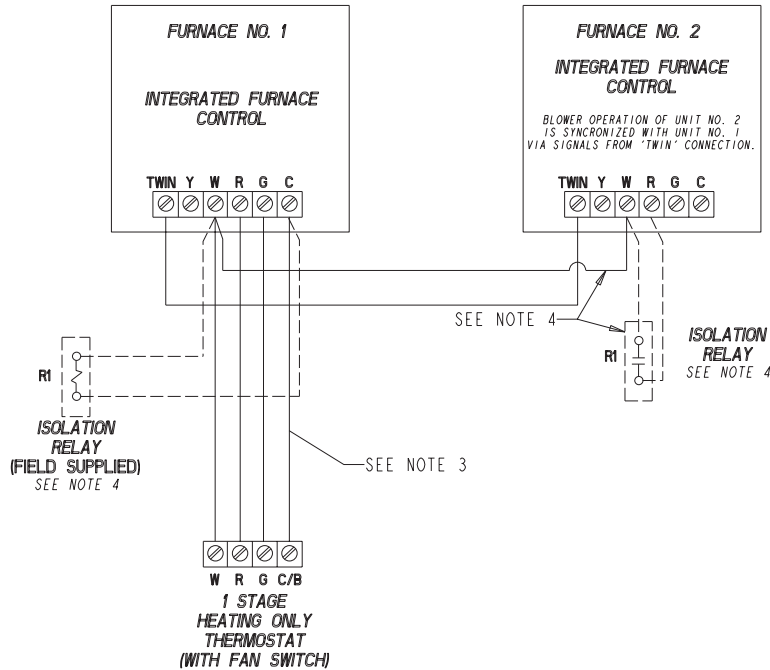

NOTES:

1. BOTH FURNACES MUST BE POWERED FROM THE SAME 115V. LEG OF CIRCUIT PANEL.
2. INSURE 24V. FURNACE TRANSFORMERS ARE IN PHASE. PRIOR TO COMPLETING CONNECTIONS, CHECK VOLTAGE BETWEEN "R" TERMINALS OF EACH FURNACE. IF VOLTAGE IS GREATER THAN 10V., REVERSE THE BL AND RD SECONDARY LEADS ON ONE OF THE FURNACE TRANSFORMERS.
3. CONNECTION MAY BE REQUIRED FOR ELECTRONIC THERMOSTAT.
4. IF CURRENT EXCEEDS THERMOSTAT CURRENT RATING, USE ISOLATION RELAYS ("R1") AS SHOWN. (DO NOT CONNECT W TO W). ISOLATION RELAY NOT NEEDED IF THE THERMOSTAT CONTACTS ARE RATED AT 1.0A. OR ABOVE.

From Dwg.. 21B341422 Rev.1

TWINNING CONNECTION DIAGRAM
FOR TWINNING 1 STAGE FURNACES WITH SINGLE WIRE TWINNING FEATURE
1 STAGE HEAT / 1 STAGE COOLING THERMOSTAT

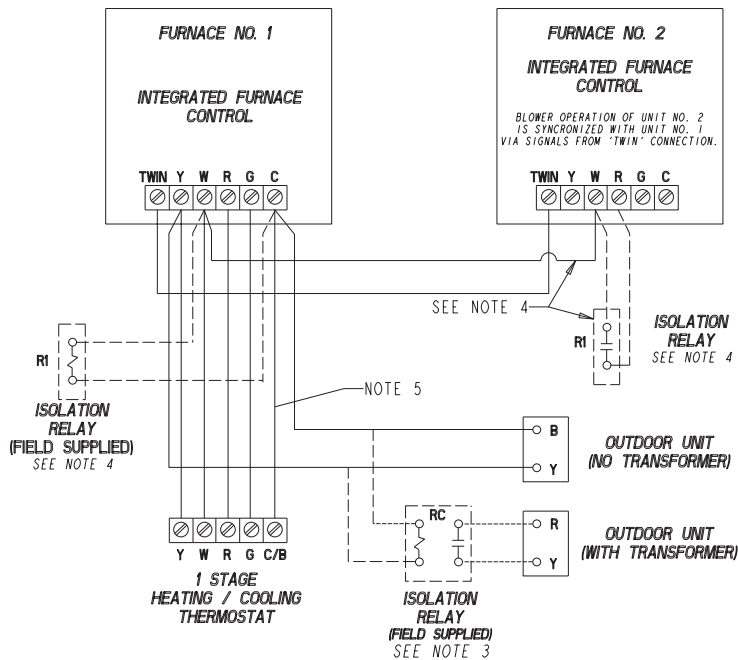

NOTES:

1. BOTH FURNACES MUST BE POWERED FROM THE SAME 115V. LEG OF CIRCUIT PANEL.
2. INSURE 24V. FURNACE TRANSFORMERS ARE IN PHASE. PRIOR TO COMPLETING CONNECTIONS, CHECK VOLTAGE BETWEEN "R" TERMINALS OF EACH FURNACE. IF VOLTAGE IS GREATER THAN 10V., REVERSE THE BL AND RD SECONDARY LEADS ON ONE OF THE FURNACE TRANSFORMERS.
3. IF OUTDOOR UNIT HAS A 24V. TRANSFORMER, AN ISOLATION RELAY MUST BE INSTALLED. (FIELD SUPPLIED - USE PILOT DUTY RELAY ("RC"), SUCH AS RLY0975.) SEE ALT. CONNECTION.
4. IF CURRENT EXCEEDS THERMOSTAT CURRENT RATING, USE ISOLATION RELAYS ("R1") AS SHOWN. (DO NOT CONNECT W TO W). ISOLATION RELAY NOT NEEDED IF THE THERMOSTAT CONTACTS ARE RATED AT 1.0A. OR ABOVE.
5. CONNECTION MAY BE REQUIRED FOR ELECTRONIC THERMOSTATS.

From Dwg.. 21B341423 Rev.1

Dimensions

TDC1 OUTLINE DRAWING
(ALL DIMENSIONS ARE IN INCHES)

MINIMUM CLEARANCE TO COMBUSTIBLE MATERIALS UPFLOW	
SIDES	0"
REAR	0"
FRONT	3"
TOP	1"
FLUE	0"
HORIZONTAL (FLUE DISCHARGE ON THE LEFT) ALCOVE	
RIGHT SIDE	0"
LEFT SIDE	0"
REAR	6"
FRONT	18"
TOP	1"
FLUE	0"
HORIZONTAL (FLUE DISCHARGE ON THE LEFT) CLOSET	
RIGHT SIDE	1"
LEFT SIDE	1"
REAR	3"
FRONT	3"
TOP	1"
FLUE	0"

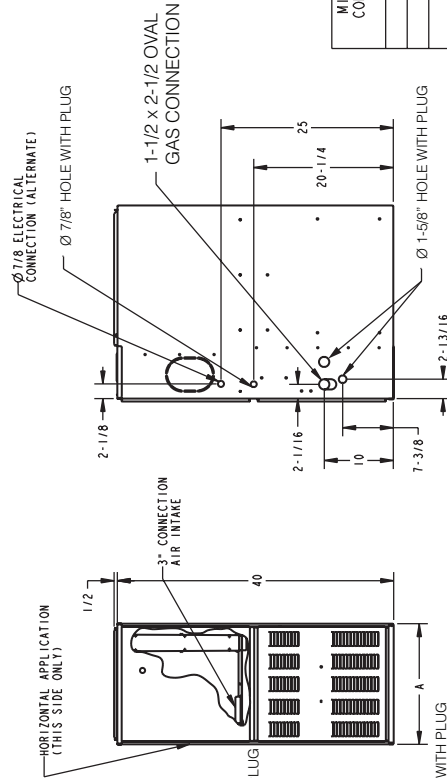

Model (See Note 1 & 2)	DIM "A"	DIM "B"	DIM "C"	DIM "D"
*DC1B040A9241	17-1/2"	2-1/4"	16-1/4"	16"
*DC1B060A9361	21"	2-1/2"	19-3/4"	19-1/2"
*DC1B080A9421	24-1/2"	2-15/16"	23-1/4"	23"

* Prefix may be "A" or "T"

Notes:

1. Diameter of Vent Pipe may be limited to 2-1/2" or 3" on some models at different altitudes. Refer to the Vent Length Table for proper application.

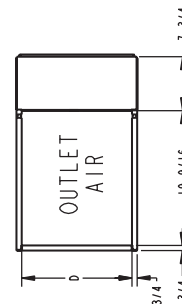
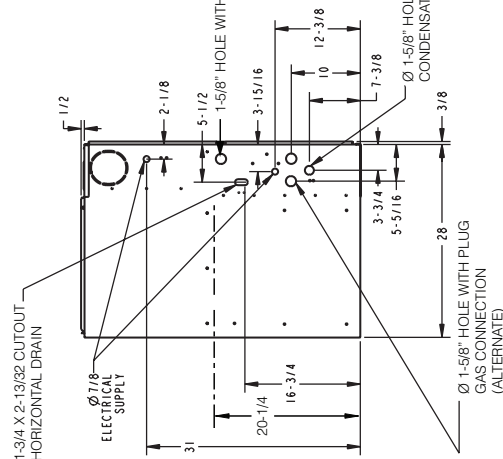
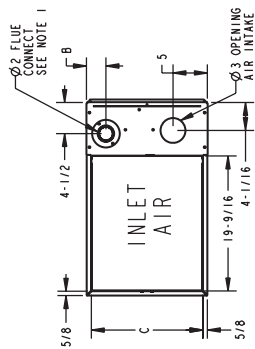



Trane
6200 Troup Highway
Tyler, TX 75707
www.trane.com



04/15

Since **Trane** has a policy of continuous product and product data improvement, it reserves the right to change design and specifications without notice.