



Product Catalog

# Modular Self-Contained Water Cooled — 40 to 80 Tons





# Introduction

## Modular Self-Contained Units

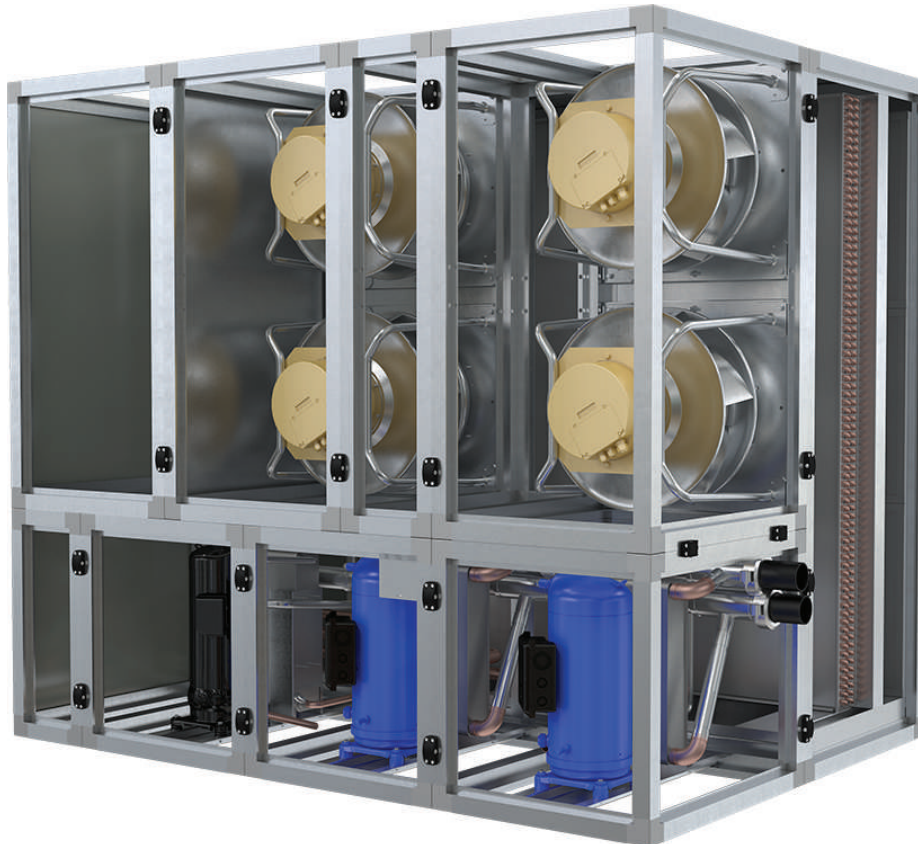

- **Unique cassette design ideal for replacement market** allowing all components to fit through a standard width commercial door and through standard IBC hallways.
- **Left hand/Right hand water connections.**
- **Left hand/Right hand electrical connections.**
- **Variable speed compressors** for highest efficiencies.
- **Plenum fan** with integrated motor, electronics, and VFD for efficient operation.
- **Unit-mounted microprocessor control** with human interface panel and touch screen.
- **Waterside valve package** option to enhance system efficiency.
- **Sight glasses** with ports for viewing unit while running.
- **Two-inch flat filter box** inside unit casing.
- **Waterside economizer** option.

## Copyright

This document and the information in it are the property of Trane, and may not be used or reproduced in whole or in part without written permission. Trane reserves the right to revise this publication at any time, and to make changes to its content without obligation to notify any person of such revision or change.

## Trademarks

All trademarks referenced in this document are the trademarks of their respective owners.

## Revision History

- Updated Controls chapter.
- Updated SCWM water-cooled self-contained, 40 to 80 tons table in General Data chapter.
- Updated Unit dimensions and Evaporator cassette dimensions tables in Dimensional Data chapter.
- Running edits.



# Table of Contents

Features and Benefits.....	5
Features .....	5
Optional Features .....	5
Benefits .....	6
Application Considerations .....	8
Modular Self-Contained Acoustical Recommendations .....	8
Isolation Recommendations .....	9
Free Cooling Opportunities and Alternatives .....	11
Unit Operating Limits .....	12
Model Number Description .....	13
Modular Self-Contained .....	13
General Data.....	14
Controls .....	17
Available Inputs and Outputs for the Unit Module (on all units with controls) .....	18
Generic BAS Option (GBAS) .....	18
BACnet/Building Automation System.....	19
Standard Unit Control Features .....	19
Control Sequences of Operation .....	19
Supply Air Temperature Control Unit Sequence of Operation.....	20
Zone Sensor Options.....	21
Electrical Data .....	22
Selection Procedures.....	22
Dimensional Data.....	26
Service Clearances.....	31
Weights.....	32
Mechanical Specifications .....	34
Modular Series Self-Contained Units .....	34
Modular Self-Contained Options .....	36



# Features and Benefits

## Features

### Standard Features

- 40 through 80 ton commercial water cooled, modular self-contained units.
- Unique Cassette Design Ideal for Replacement Market allowing all components to fit through a standard 36-inch width commercial door and through standard IBC 44-inch hallways.
- Variable Speed Technology on lead compressor for highest efficiencies.
- Available with lower MCA design ideal for retrofit applications.
- Fully integrated, factory-installed, and commissioned microelectronic controls.
- Variable Air Volume (VAV) operation.
- Direct Drive Plenum Fans with Integrated Motor, Electronics and VFD's.
- Emergency stop input.
- Units are shipped with Nitrogen.
- Factory piped, chemically cleanable, brazed plate condensers for efficient operation and modularity. Condensers do not need to be removed from unit for cleaning.
- Upstream inline 20 mesh strainer for added protection along with alerts for when strainer needs to be cleaned.
- Sloped drain pans to ensure complete condensate removal for IAQ.
- Expansion Valves and Filter Driers are easily accessible.
- Access panels and clearance provided to clean both evaporator and waterside economizer coil fins.
- Shipped as individual cassettes.
- One inch insulated panel modular frame construction.
- Panels meet UL1995, ASTM E84/UL 723 for flame spread and smoke develop rating.

### Standard Control Features

- Durable unit-mounted touch screen display. The 7-inch WVGA 800 x 480 resolution touchsensitive color screen is backlit, which enables viewing in poor light conditions including outdoor usage.
- Phase reversal protection provided in each compressor - fixed or variable.
- Compressor lead/lag on fixed speed compressors.
- Fan failure detection.
- Occupied/unoccupied switching.
- Programmable water purge during unoccupied mode.
- High leaving air temperature limit.
- BACNet® communication by MSTP.

### Optional Features

- Generic BAS interface.
- Waterside modulating with spring return temperature control valves include factory installed piping and control wiring.
- Fully integrated, factory-installed/commissioned variable frequency drive control.
- Protective coatings for the evaporator coils.
- Stainless steel sloped drain pan.
- Medium efficiency throwaway filters.
- Non-fused external disconnect switch.
- Left hand/right hand electrical connections.
- Left hand/right hand water connections.
- 2- and 4-inch filter racks for all sizes.
- Condensing pressure control on all variable water flow systems with valves.

**Note:** A water flow switch is required for the installation, either supplied from the factory or field-provided.



## Features and Benefits

---

### Factory-Installed or Ship-Separate Options

- Waterside economizer with factory-installed piping and controls.
- Optional clean in place fittings on brazed plate condensers.
- Field-Installed Accessories.

## Benefits

### Servicing Advantages

- Strategically placed service doors with easy access to critical components
- Cassette Concept allows for easier maintenance than other built-up systems
- Field connected power/control wiring is color-coded and individually keyed for easy installation and quality assurance

### Tenant Satisfaction

- Complete HVAC system on each floor minimizes tenant inconvenience during routine maintenance
- Tenants can control system after hours to increase productivity and minimize expense

### Lower Installed Cost

- Single point power connection. Left hand to right hand electrical connections for easier installation into existing applications
- Single point water connection. Left hand or right hand water connections for easier installation in existing applications
- Factory-commissioned and tested controls
- Factory-installed options
- Internally trapped drain connection
- Available with low MCA VSD to meet the needs of retrofit applications, while still gaining benefits of Variable Speed Technology

### Economical Operation

- Free cooling with optional waterside economizer
- Energy savings with floor-by-floor system since only units on floors requiring cooling need to operate
- Variable speed compressors for increased efficiency
- Variable speed plenum fans for increased efficiency
- Energy savings from the integrated water valve control using pump unloading

### Assured Acoustical Performance

- Double wall insulated panels assure quiet operation
- Multiple compressor design reduces acoustical levels. Scroll compressor design smooths gas flow for quieter operation

### Indoor Air Quality (IAQ) Features

- Stainless steel sloped drain pan option.
- Double wall insulated panel modular frame construction
- High-efficiency throwaway filter option
- Easily cleanable evaporator, condensers, and waterside economizers
- Filter access door allows easy removal to encourage frequent filter changing

**Enhanced Serviceability**

- Access Doors for ease of service
- Hinged and removable panels on all components
- Easy to adjust setpoints and operating parameters using the human interface panel on units
- Refrigerant line sight glasses in view during operation

**Competitive Advantage**

- Cassette construction for transporting unit components into the most demanding spaces
- Optional left hand/right hand electrical connections meets the needs of the mechanical room
- Optional left hand/right hand water connections meets the needs of the mechanical room
- Compact cabinet to minimize mechanical room requirements
- Up to 17% more efficient than competitive units
- Low leaving air temp capability to reduce fan motor energy, improve acoustical performance, and minimize duct sizes
- Factory-installed and tested microprocessor controller

**Variable Frequency Drives (VFD)**

- Variable frequency drives on the fans are integral to the fans and are tested in the factory. Easy field wiring ensures quick/easy startup.
- Variable frequency drive on the lead compressor are factory installed and tested. Easy field wiring ensures quick and easy startup.

# Application Considerations

## Modular Self-Contained Acoustical Recommendations

Successful acoustical results are dependent on many system design factors.

Following are general acoustical recommendations. For more information, or if there is concern about a particular installation, contact a professional acoustical consultant.

### Location and Orientation of the Mechanical Equipment Room

Locate the equipment room adjacent to stairwells, utility rooms, electrical closets, and rest rooms if possible, to minimize the acoustic effects and risk of workmanship or installation errors. (See figure below) Place the discharge and return air ductwork over these less acoustically sensitive areas, using vertical or horizontal fresh air shafts. Consult code requirements for fresh air and smoke purge constraints.

**Figure 1. Equipment room and location and orientation**

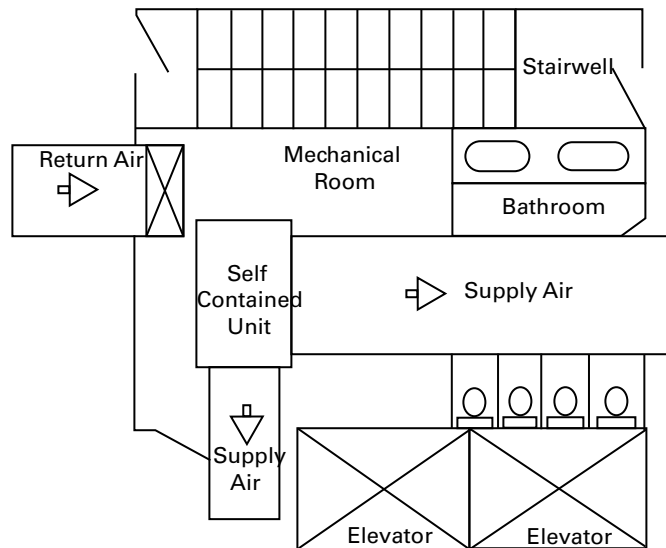

### Return Air Ductwork

Duct the return air into the mechanical equipment room. Connect ductwork to the unit if local code dictates. The return air ductwork must have an elbow inside the equipment room. This elbow will reduce sound transmissions through the return duct. Extend the ductwork from the elbow far enough to block the “line of sight” to the exterior of the equipment room. Use a minimum ductwork length of 15 feet to the equipment room exterior. Line the duct with two-inch, three-pound density insulation. Use multiple, small return ducts for better acoustical performance to the occupied space.

### Supply Air Ductwork

Insulate the supply air duct with two-inch, three-pound density insulation. Extend this lining at least 15 feet out from the equipment room wall, keeping the duct aspect ratio as small as possible. Minimize large flat panels since they transmit sound. In addition, small aspect ratios will minimize potential “oil canning” of the duct due to flow turbulence.

The flexible horizontal discharge plenum option helps avoid complicated ductwork transitions. Ductwork turning vanes typically improve pressure drop but degrade acoustical performance.

### Recommended Maximum Air Velocities

The maximum recommended velocity for the discharge air duct is 2,000 fpm. The maximum recommended velocity for the return air duct is 1,000 fpm. Limit air velocities below these operating points to minimize the risk of flow turbulence that causes regenerated noise. Using



round supply duct and static regain allows maximum discharge air velocities up to 3,000 fpm. Lining round supply duct also substantially lowers frequency noise attenuation. However, flow regenerated noise potential increases dramatically at air velocities over 3000 fpm.

### Equipment Room Construction Options

The preferred equipment room wall construction is concrete block. If this is not feasible then a double stud offset wall is suggested (See figure below). This removes physical contact that would transmit sound through the equipment room wall to the occupied space. Interweave fiberglass insulation between the wall studs. Use two layers of drywall on each side of the wall.

Workmanship details are critical to acoustical performance. Seal all wall and floor penetrations by the ductwork, water piping, and equipment room access doors with a flexible material such as caulk and/or gasketing to stop noise and air leaks.

Locate the equipment room door away from acoustically sensitive areas like conference rooms. The door should swing out of the equipment room, if possible, so that the low pressure in the equipment room pulls the door in to help maintain a tight seal.

**Figure 2. Double stud offset wall with interwoven insulation**

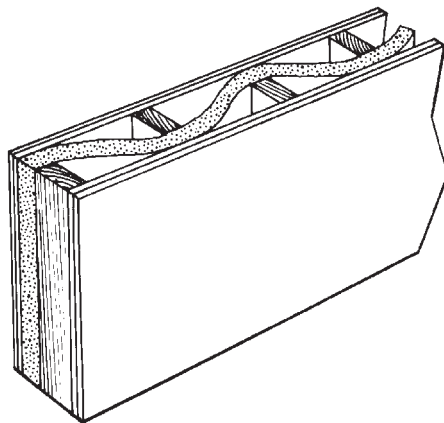

### Static Pressure Versus Acoustics

Design the system to minimize the total static pressure required from the self-contained unit fan. Typically a change in static pressure of only 0.5 inches can reduce NC level by approximately 2 or 3 in the occupied space.

### Isolation Recommendations

#### Unit

The compressors are internally isolated. All fans are factory balanced. The unit fan and compressors are internally isolated. Therefore, external isolation is not required. Consult a vibration specialist before considering external or double vibration isolation.

#### Ductwork

Design duct connections to the unit using a flexible material. Consult local codes for approved flexible duct material to prevent fire hazard potential.

#### Piping Connections

Rubber isolator connectors are recommended for condenser piping to prevent vibration transmission to or from the building plumbing. The self-contained unit is internally isolated and does not require additional isolation. However, ensure that proper system vibration isolation design prevents vibration transmission from the building plumbing to the unit. Also be sure to properly isolate the drain line.



### Condenser Water Piping

#### Piping Location and Arrangement

Provide at least 24 inches of clearance between the piping and the unit for service. Place the risers away from the side of the unit if possible. Be sure to allow sufficient space for valves and unions between the piping and the self-contained unit. Lay out condenser piping in reverse returns to help balance the system. This is accomplished by equalizing the supply and return pipe length. Multi-story buildings can use a direct return system with balancing valves at each floor. Install all heat exchangers and most cooling tower piping below the sump operating water level to prevent overflow during unit and/or system shut down.

#### Recommended Pump Location

Locate pump downstream of the cooling tower and upstream of the modular self-contained unit. This provides smoother and more stable unit operation.

When the tower and pump are both roof mounted, be sure to provide the necessary net positive suction head pressure to prevent cavitation. Raise the tower or submerge the pump in a sump to provide positive suction. To prevent an on-line pump failure, use a standby pump to avoid a complete system shutdown.

Several partial capacity pumps or variable speed pumps can be used. Review the economics of these alternate pumping options.

#### Strainers and Water Treatment

Water strainers are required at the unit inlet to eliminate potential unit damage from dirty water. Each unit will be supplied with a field installed 20 mesh strainer. The unit also comes standard with differential pressure monitoring that can be used to alert owner when 20 mesh screen requires cleaning. Untreated or poorly treated water may result in equipment damage. Consult a water treatment specialist for treatment recommendations.

#### Isolation Valves

Install isolation valves at each unit before the strainer and after the condenser. This allows periodic servicing of the unit or strainer while allowing other units in the system to remain in operation.

#### Pressure Gauges

Install pressure gauges on the inlet and outlet of the self-contained unit. Select the gauge's scale so that the unit design operating point is approximately mid-scale.

#### Thermometers

Install thermometers on the condenser water inlet and outlet lines to each unit for system analysis. Trane® recommends using a thermometer temperature range of 40°F to 140°F, using a 2°F temperature increment.

#### Drains

Install a trapped drain in the low point of the mechanical equipment room floor to collect water from cleaning operations.

**Note:** Units are not internally trapped. Externally trapped drain must be added in the field.

#### Condensing Pressure Control (Water-Cooled Condensers)

Often cold condensing water applications between 35°F and 54°F require a condensing pressure control valve. However, to utilize this feature, the building water system must be capable of operating at reduced water flow rates through the modular self-contained units. It is imperative to install variable volume pumps or an external bypass in the water distribution system.

#### Waterside Economizer Flow Control

Units equipped with waterside economizer and intermediate piping package can be set up for variable or constant water flow.

Use constant water flow setup on water systems that are not capable of unloading water supply to the unit. The economizer and condenser valves will operate in complement to one another to provide continuous water flow.

Use variable water flow setup with water flow systems that can take advantage of pump unloading for energy savings. Since non-cooling operation restricts water flow during part load economizing or condensing temperature control, it is imperative to install variable volume pumps or an external bypass in the water distribution system.

**Figure 3. Waterside economizer flow control**

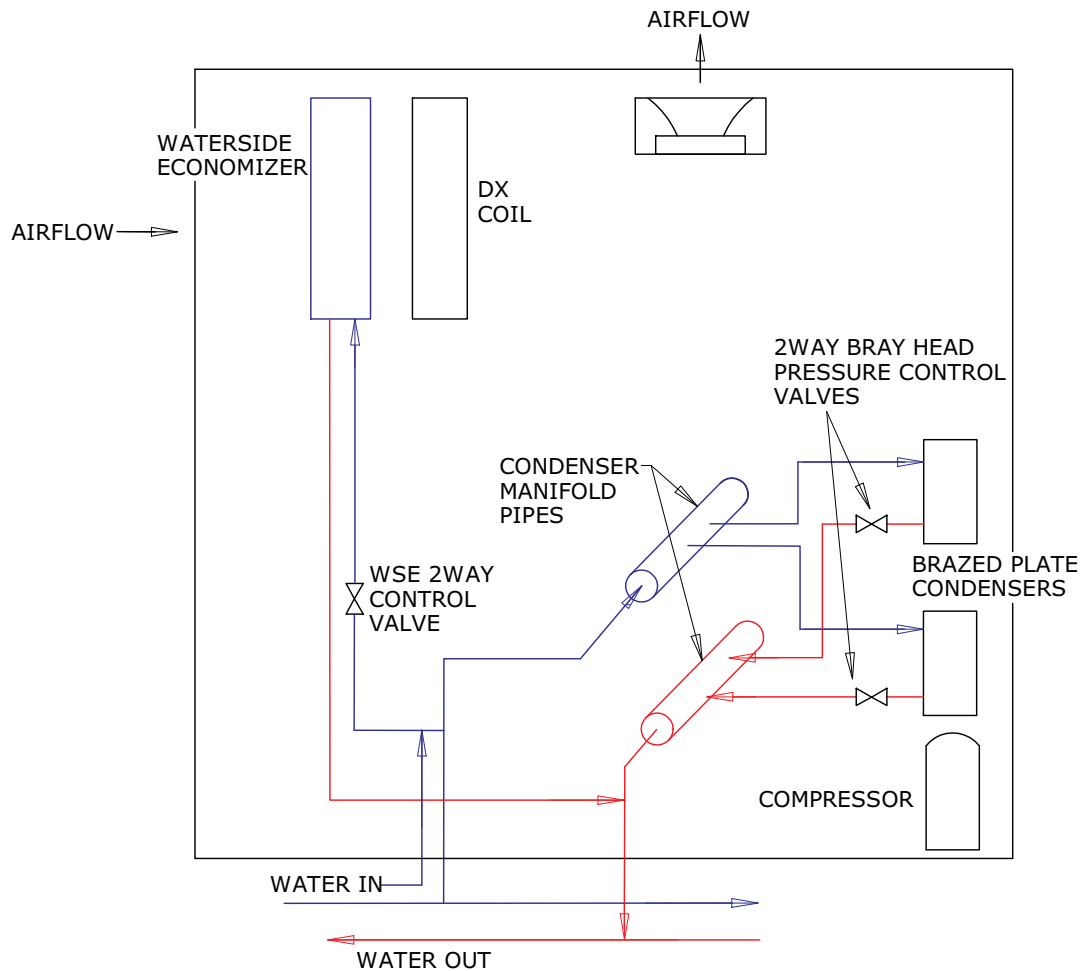

## Free Cooling Opportunities and Alternatives

Free cooling is available with waterside economizer options. The advantages are listed as follows:

### Waterside Economizer

The waterside economizer substantially reduces the compressor energy requirements because it uses the cooling water before it enters the condensers. Additional equipment room space is not required since the coils are contained within the overall unit dimensions.

Disadvantages include higher airside pressure drop and a higher head on condenser water pumps.



## Application Considerations

---

### Unit Operating Limits

#### Airflow

The minimum recommended airflow for proper VAV system staging and temperature control is 35 percent of nominal design airflow. Adjusting VAV boxes with the appropriate minimum settings prevents the self-contained unit from operating in a surge condition at airflows below this point. Continuous operation in a surge condition can cause fan failure.

**Note:** Contact your local Trane sales office for minimum airflow conditions.

#### Water Flow

Use 3 gpm/ton for optimum unit capacity and efficiency. Use 2.5 or 2 gpm/ton to reduce pump energy, cooling tower, and piping costs. However, these reduced water flows may impact unit capacity and efficiency by one or two percent. Consult factory for unit specific water flow ranges.



# Model Number Description

## Modular Self-Contained

### Digit 1 — Unit Model

**S** = Self-Contained

### Digit 2 — Unit Type

**C** = Commercial

### Digit 3 — Condenser

**W** = Water-cooled

### Digit 4 — Construction

**M** = Modular

### Digit 5 — Refrigerant

**N** = Nitrogen

**R** = R410A

### Digit 6, 7, 8 — Capacity

**04L** = 40 Tons Low MCA

**040** = 40 Tons

**05L** = 50 Tons Low MCA

**050** = 50 Tons

**06L** = 60 Tons Low MCA

**060** = 60 Tons

**07L** = 70 Tons Low MCA

**070** = 70 Tons

**08L** = 80 Tons Low MCA

**080** = 80 Tons

### Digit 9 — Unit Voltage

**F** = 208-230/60/3

**4** = 460/60/3

### Digit 10, 11 — Design Sequence

**00** = Initial Release

### Digit 12 — Number of Fans

**3** = 3 Fans

**4** = 4 Fans

**5** = 5 Fans

**6** = 6 Fans

### Digit 13 — Compressor Configuration

**A** = 2 Compressors (1 Variable, 1 Fixed)

**B** = 3 Compressors (1 Variable, 2 Fixed)

**C** = 4 Compressors (2 Variable, 2 Fixed)

### Digit 14 — Control Valves

**0** = None

**H** = Head Pressure Control Valves

### Digit 15 — Condenser Cleanable Options

**0** = None

**C** = Clean in Place Fittings (Chemically Cleanable)

### Digit 16 — Economizer

**0** = No Economizer

**W** = With Water Side Economizer

### Digit 17 — Water Connections

**L** = Left Hand Connections

**R** = Right Hand Connections

### Digit 18 — Unit Water Connections

**1** = Victaulic

**2** = Pipe Connections

### Digit 19 — Air Discharge

**H** = Horizontal Discharge

**V** = Vertical Discharge

### Digit 20 — Electrical Connections

**L** = Left Hand Connections

**R** = Right Hand Connections

### Digit 21 — Unit Electrical Connections

**1** = Disconnect Switch

**2** = Terminal Block

### Digit 22 — Drain Pan

**G** = Galvanized Drain Pan

**S** = Stainless Steel Drain Pan

### Digit 23 — Industrial Options

**0** = None

**A** = Protective Coating Evaporator Coil

### Digit 24 — Filter Type

**A** = 2 inch

**B** = 4 inch

**C** = 2 inch Pre, 4 inch Post

**D** = 6 inch

### Digit 25 — Heater

**0** = None

**1** = Hydronic

### Digit 26 — Shipping Method

**C** = Cassette

### Digit 27 — Unit Isolators

**0** = None

**A** = Isopads

### Digit 28 — Control Interface Options

**A** = UC600 VAV Control Scheme (Fixed DA Temp)

**B** = UC600 VAV Control Scheme (Return Air Reset)

**C** = UC600 VAV Control Scheme (Space Temp Reset)

### Digit 29 — Agency Listing

**0** = None

**E** = ETL listing

### Digit 30 — Options

**0** = None

**1** = Duct High Temperature Cutout

### Digit 31 — Space Sensor Options

**0** = None

**1** = Space Sensor Only

### Digit 32 — GBAS Options

**0** = None

**1** = GBAS Points Included

### Digit 33, 34, 35, 36, 37, 38 — Future Use

**0** = None

### Digit 39 — Major Design Version

**A** = 1.0

### Digit 40 — Design Special

**0** = None

**S** = Design Special



# General Data

**Table 1. SCWM water-cooled self-contained, 40 to 80 tons**

Tonnage	40L Ton	40 Ton	50L Ton	50 Ton	60L Ton	60 Ton	70L Ton <sup>(a)</sup>	70 Ton <sup>(a)</sup>	80L Ton <sup>(a)</sup>	80 Ton <sup>(a)</sup>	
<b>Compressor Data</b>											
Quantity	1VS- 1FS	1VS- 1FS	1VS- 2FS	1VS- 2FS	1VS- 2FS	1VS- 2FS	1VS- 3FS	1VS- 3FS	1VS- 3FS	1VS- 3FS	
Nominal Ton/Comp	10T- 15T	15T- 15T	10T- 13T	15T- 13T	10T- 15T	15T- 15T	10T- 13T	15T- 13T	10T- 15T	15T- 15T	
Circuits	2	2	3	3	3	3	4	4	4	4	
<b>Evaporator Coil Data</b>											
Rows	4	4	3	3	4	4	4	4	4	4	
Sq. Ft.	25.5	25.5	33	33	38	38	19.8	33.3	19.8	33.3	
Fins/in	13.5	13.5	13.5	13.5	13.5	13.5	13.5	13	13.5	13.5	
Number of Coils	1	1	1	1	1	1	1	1	1	1	
<b>Condenser Data</b>											
Minimum GPM w/o Econ <sup>(b)</sup>	N/A	N/A	N/A	N/A	N/A	N/A	N/A	N/A	N/A	N/A	
Minimum GPM w/ Econ	N/A	N/A	N/A	N/A	N/A	N/A	N/A	N/A	N/A	N/A	
Maximum GPM	140	140	210	210	210	210	280	280	280	280	
<b>Evaporator Fan Data</b>											
Quantity	3	3	3	3	4	4	5	5	5	5	
Diameter	500 mm	500 mm	500 mm	500 mm	500 mm	500 mm	500 mm	500 mm	500 mm	500 mm	
Power consumption kW	6.4	6.4	6.4	6.4	6.4	6.4	6.4	6.4	6.4	6.4	
Minimum Design cfm <sup>(c)</sup>	11000	11000	13750	13750	16500	16500	19250	19250	22000	22000	
Maximum Design cfm	16000	16000	20000	20000	24000	24000	28000	28000	32000	32000	
<b>Refrigerant Charge, lbs. R-410A<sup>(d)</sup></b>											
Circuit A	17	18	17	18	17	18	20	21	20	21	
Circuit B	19	19	18	18	19	19	18	18	19	19	
Circuit C	x	x	18	18	19	19	18	18	19	19	
Circuit D	x	x	x	x	x	x	17	17	18	18	
<b>Filter Data, Water-Cooled Units</b>											
Number - Size (in.)	9 - 24"x 20"		12 - 24"x 20"				15 - 24"x 24"				
<b>Number of Compressors</b>											
10 HP - Variable Speed	1	0	1	0	1	0	1	0	1	0	
15 HP - Variable Speed	0	1	0	1	0	1	0	1	0	1	
13 HP - Fixed Speed	0	0	2	2	0	0	3	3	0	0	
15 HP - Fixed Speed	1	1	0	0	2	2	0	0	3	3	
<b>Number of fans/unit</b>											
No. of fans	3				4			5			

**Note:** All performance data is provided in the Performance Selection Program. Contact Trane Sales at 770-988-8338 for more information.

<sup>(a)</sup> Split coils

<sup>(b)</sup> All performance data is provided in the Performance Selection Program. Contact MJC Sales at 770-988-8338 for more information.

<sup>(c)</sup> Minimum air flow at part load is 35% of full load design CFM.

<sup>(d)</sup> Refrigerant charge shown is a general guideline, charge to sub-cooling as described in IOM. Note that occasionally a TXV adjustment may need to be made but only after adequate sub-cooling has been reached.

**Table 2. SCWM EER/IEER ratings**

Tonnage	Model No.	EER	IEER (VAV)	AHRI Net Cooling Capacity (BTUH)
40	SCWMN04LF	15.8	20.6	408
	SCWMN040F	14.8	20.6	468
	SCWMN04L4	15.8	20.6	408
	SCWMN0404	14.8	20.6	468
50	SCWMN05LF	15.8	19.5	540
	SCWMN050F	14.9	19.5	600
	SCWMN05L4	15.8	19.5	540
	SCWMN0504	14.9	19.5	600
60	SCWMN06LF	15.7	18.5	636
	SCWMN060F	14.8	18.5	696
	SCWMN06L4	15.7	18.5	636
	SCWMN0604	14.8	18.5	696
70	SCWMN07LF	15.8	19.5	780
	SCWMN070F	14.9	19.5	840
	SCWMN07L4	15.8	19.5	780
	SCWMN0704	14.9	19.5	840
80	SCWMN08LF	15.7	20.8	876
	SCWMN080F	14.7	20.8	936
	SCWMN08L4	15.7	20.8	876
	SCWMN0804	14.7	20.8	936

**Notes:**

1. Cooling Only
2. Cooling performance is rated at 80F EDB/67F EWB with 85 EWT for water-cooled performance and 95F Ambient for air-cooled performance.
3. EER, IEER, and AHRI Net Cooling Capacity are tested in accordance with the AHRI 340/360 (I-P) and certified to 10 CFR Part 431 from the US Department of Energy.

**Table 3. SCWM water volumes**

Tonnage	Water Volume in U.S. Gallons/Liters			
	w/o Economizer		With Chem. Cleanable Econ, Add	
	Gallons	Liters	Gallons	Liters
40 Ton	8.2	31	12	45.4
50 Ton	9.7	36.7	14.4	54.5
60 Ton	9.7	36.7	19.1	72.3
70 Ton	12.9	48.9	24	90.8
80 Ton	12.9	48.9	24	90.8

**Table 4. SCWM refrigerant circuits, number of compressors by circuit**

Tonnage	Model No.	Circuit			
		1	2	3	4
40	SCWMN04L	1-10T VS	1-15T FS	N/A	N/A
	SCWMN040	1-15T VS	1-15T FS	N/A	N/A
50	SCWMN05L	1-10T VS	1-13T FS	1-13T FS	N/A
	SCWMN050	1-15T VS	1-13T FS	1-13T FS	N/A



## General Data

**Table 4. SCWM refrigerant circuits, number of compressors by circuit (continued)**

Tonnage	Model No.	Circuit			
		1	2	3	4
60	SCWMN06L	1-10T VS	1-15T FS	1-15T FS	N/A
	SCWMN060	1-15T VS	1-15T FS	1-15T FS	N/A
70	SCWMN07L	1-10T VS	1-13T FS	1-13T FS	1-13T FS
	SCWMN070	1-15T VS	1-13T FS	1-13T FS	1-13T FS
80	SCWMN08L	1-10T VS	1-15T FS	1-15T FS	1-15T FS
	SCWMN080	1-15T VS	1-15T FS	1-15T FS	1-15T FS

**Note:** VS - Variable Speed Compressor, S - Fixed Speed Compressor

**Table 5. Waterside economizer coil physical data**

Model	Unit Size	Rows	FPF	Height	Length
MSC	40 Ton	4	150	75	49
MSC	50 Ton	4	150	75	65
MSC	60 Ton	4	150	75	73
MSC <sup>(a)</sup>	70 Ton	4	150	75	38
		4	150	75	64
MSC <sup>(a)</sup>	80 Ton	4	150	75	38
		4	150	75	64

<sup>(a)</sup> Split coils

**Table 6. Hot water coil physical data**

Model	Unit Size	Rows	FPF	Height	Length
MSC	40 Ton	1	156	75	49
MSC	50 Ton	1	156	75	65
MSC	60 Ton	1	156	75	73
MSC <sup>(a)</sup>	70 Ton	1	156	75	45
		1	156	75	45
MSC <sup>(a)</sup>	80 Ton	1	156	75	45
		1	156	75	45

<sup>(a)</sup> Split coils

**Important:** All performance data is provided in the Performance Selection Program. Contact your local Trane Sales office for more information.





# Controls

The Trane Modular Self-Contained unit is controlled through Trane Tracer™ UC600 controller programmed with specific controls sequences to meet the needs of the unit configuration and application.

The Trane Modular Self-Contained unit includes Trane UC600 unit controls and the TD7 touch screen display.

Depending upon unit options, units can operate as follows:

- Stand-alone
- Interface with BACnet MS/TP building management system
- Interface with an optional Generic Building Automation System (GBAS)

**Figure 4. UC600**



**Figure 5. XM70**



**Figure 6. TD7 display**

## Available Inputs and Outputs for the Unit Module (on all units with controls)

### Binary Inputs

- Emergency stop
- External auto/stop
- Unoccupied/occupied
- Dirty filter

### Binary Outputs

- VAV box drive max (VAV units only)
- Alarm
- Fan run request
- Water pump request (water-cooled only)

## Generic BAS Option (GBAS)

### Binary Outputs

- Dirty filter relay
- Refrigeration fail relay
- Supply fan fail relay

### Analog Inputs

- Occupied zone cooling setpoint
- Occupied zone heating setpoint
- Unoccupied zone cooling setpoint
- Unoccupied zone heating setpoint
- Supply air cooling setpoint
- Supply air heating setpoint
- Supply air static pressure setpoint

## BACnet/Building Automation System

The UC600 utilizes the BACnet defined MS/TP protocol as defined in ASHRAE standard 135-2004. This controller works in standalone mode, with Tracer® SC+ or when connected to a third party building automation system that supports BACnet.

## Standard Unit Control Features

*Note: All set-up parameters are preset from the factory, requiring less start-up time during installation.*

### Unit Features

- Durable unit-mounted touch screen display. The 7-inch WVGA 800 x 480 resolution touch-sensitive color screen is backlit, which enables viewing in poor light conditions including outdoor usage.
- Compressor lead/lag for units with two or more fixed speed compressors
- Fan failure detection
- Occupied/unoccupied switching
- Programmable water purge during unoccupied mode

## Control Sequences of Operation

### Generic Building Automation System Module (GBAS) Option

The generic building automation system module (GBAS) provides broad control capabilities for building automation systems other than Trane Tracer® systems. A field-provided potentiometer or a 0-5 Vdc signal can be applied to any of the inputs of the GBAS to provide the following inputs and outputs:

#### GBAS Analog Inputs

Analog inputs that are pre-defined to be the following:

- Occupied zone cooling
- Unoccupied zone cooling
- Occupied zone heating
- Unoccupied zone heating
- SA cooling setpoint
- SA heating setpoint
- SA static pressure setpoint

### Occupied/Unoccupied Switching

There are three ways to switch occupied/unoccupied:

- Field-supplied contact closure (hardwired binary input to field wiring terminal block (2TB3))
  - This input accepts a field supplied switch or contacts closure such as a time clock.
- BACnet BAS system can control the occupied/unoccupied request of the self-contained unit.
- Through the TD7 Display via the on-board schedule.

### Compressor Lead/Lag

Compressor lead/lag is present in the controls for all units with two or more fixed speed compressors. Only Compressors 2 and 3 rotate. Balanced run hours is achieved by changing the Fixed Speed compressors sequence number when commanded to rotate.

Variable speed compressor A is always the first and last stage of mechanical cooling.



## Emergency Stop Input

A binary input is provided on the unit's field wiring terminal block (2TB3) for installation of a field-provided switch or contacts to immediately shutdown all unit functions.

## External Stop Input

A binary input is provided on the unit's field wiring terminal block (2TB3) for installation of a field-provided switch or contacts to safely shutdown all unit functions.

## Local Auto Stop

A binary value is located on the TD7 which allows the user to start and stop the unit in a safe manner for maintenance. On the TD7 home screen in the upper right hand corner the unit can be put into Auto to perform normally or Stop to perform a controlled shutdown and keep the unit off.

## Water Flow Control

The standard configuration of a unit is with constant water flow. With compatible piping configurations, the unit can be configured to provide orderable option variable water flow, which maximizes energy saving by unloading the water pumping system.

## Head Pressure Control

Water-cooled condensers — Units that are ordered with the optional flow control valves and configured for variable water flow will modulate a water valve to maintain both the user-defined refrigerant condenser pressure and refrigerant pressure differential setpoints. Refrigerant pressures will be referenced utilizing factory installed suction and discharge pressure sensors located at each compressor.

## Water Purge

This user-definable feature allows the user to select a purge schedule to automatically circulate water through the economizer and condensers periodically during non-operational times. This allows fresh chemicals to circulate in waterside heat exchangers.

## Supply Air Static Pressure High Limit

During normal operation, the Supply Air Static is monitored. If at any time the static pressure exceeds the software high static limit (defaulted at 2.0 inches from the factory) the unit will immediately shut down and generate a diagnostic.

In order for the unit to resume operation, the Alarm Reset must be toggled from the TD7. The software high static limit can be user adjusted at the TD7.

# Supply Air Temperature Control Unit Sequence of Operation

## 1 — Occupied Supply Air Temperature Control

### Cooling/Waterside Economizer

During occupied cooling mode, the waterside economizer option and mechanical cooling are used to control the supply air temperature. The supply air temperature setpoint is user defined at the human interface panel.

After the fans run for 5 minutes, and a call for cooling is calculated, the Cooling Tower/Pump Command is turned on. After the Condenser Water flow switch closes proving flow, the Compressors and/or Economizer will be allowed to start.

Waterside economizing enables when the unit's entering water temperature is less than the entering mixed air temperature. This is set at Waterside Economizer Enable Offset setpoint. The factory default is 7°F, but can be adjusted by the user in the TD7 or via BACnet.

The economizer acts as the first stage of cooling. If the economizer is unable to maintain the supply air setpoint, the unit controller will bring on the compressors as required to meet the

setpoint. If the unit does not include an economizer, only mechanical cooling will satisfy cooling requirements.

### **Discharge Air Cooling Setpoint**

The Discharge Air Cooling Setpoint BAS default value of 55 degrees and the unit will control to this value when in the cooling mode. This method is used directly from the factory when digit 28 of the model number is set to A. The setpoint can be adjusted 3 different ways.

### **Building Automation Control of setpoint**

Anytime a BAS system controls the Discharge Air Cooling Setpoint BAS at a priority level it will take precedence over locally calculated values in the Cooling Mode.

### **Reset Based on Return Air Temperature (Ordered Option of Digit 28 set to B)**

The Discharge Air Temperature can be reset based off the return air temperature which will work to keep this temperature between its heating and cooling setpoints.

### **Reset Based on Zone Temperature (Ordered Option of Digit 28 set to C)**

The Discharge Air Temperature can be reset based off the return air temperature which will work to keep this temperature between its heating and cooling setpoints.

### **Reset Based on Zone Temperature**

Zone reset is applied to the zone(s) in a building that tends to overcool or overheat. The supply air temperature setpoint is adjusted based on the temperature of the critical zone(s). This can have the effect of improving comfort and/or lowering energy usage. The user-defined parameters are the same as for outdoor air reset.

### **Heat/Cool Mode**

The unit is in Cooling mode by default. The front end Building Automation System will switch the Heat Cool Mode Request Multistate Value between the Heating and Cooling modes to get the desired control.

### **Heating Operation**

During occupied heating mode, the hot water valve modulates to maintain the discharge air setpoint.

### **Discharge Air Heating Setpoint**

The Discharge Air Heating Setpoint BAS default value of 95 degrees and the unit will control to this value when in the heating mode.

## **Zone Sensor Options**

### **Zone Temperature Sensor, BAYSENS077**



This zone sensor includes an internal thermistor and should be mounted in the zone, Model Number Digit 31=1. This sensor is available for use with all zone sensor options to provide remote sensing capabilities.

Additional sensors are also available for order using the Model Number Digit 31.



# Electrical Data

## Selection Procedures

- RLA = Rated Load Amps
- Compressor LRA = Locked Rotor Amps
- Compressor Input = VFD drive Input
- Compressor Output = VFD drive output
- Voltage utilization range is  $\pm 10\%$

### Determination of Minimum Circuit Ampacity (MCA)

MCA = 1.25 x Largest motor amps/VFD Input + the sum of the remaining motor amps.

### Determination of Max Fuse (MFS) and Max Circuit Breaker (MCB) Sizes

MFS and MCB = 2.25 x Largest motor amps (RLA)/VFD input) + the sum of the remaining motor amps.

If the rating value calculation does not equal a standard over current protective device rating, use the next lower standard rating as the maximum.

**Table 7. Number of compressors**

MSC	SCWMN 04L	SCWMN 40	SCWMN 05L	SCWMN 50	SCWMN 06L	SCWMN 60	SCWMN 07L	SCWMN 70	SCWMN 08L	SCWMN 80
66cc - ZPV0662	1	0	1	0	1	0	1	0	1	0
96cc - ZPV0962	0	1	0	1	0	1	0	1	0	1
ZP154KCE-TE	0	0	2	2	0	0	3	3	0	0
ZP181KCE-TE	1	1	0	0	2	2	0	0	3	3

**Table 8. Number of fans**

	40 Tons	50 Tons	60 Tons	70 Tons	80 Tons
Drive (K3G500) - Motor (M3G150-IF)	3	3	4	5	5

**Table 9. Compressor electrical data**

Tons	MSC Compressor	200		460		200	460
		RLA	LRA	RLA	LRA	MAX INPUT	MAX INPUT
10	66CC - ZPV0662 (VFD)	-	-	-	-	56	30
15	ZP181KCE-TE	55.77	340	23.72	110	-	-
	96CC-ZPV0962 (VFD)	-	-	-	-	84	60
13	ZPV154KCE-TE	51.28	300	23.7	150	-	-

**Table 10. Fan motor electrical data**

	200	460
	INPUT	INPUT
Drive (K3G500) - Motor (M3G150-IF)	18.6	9

**Table 11. Electrical service sizing data – motors – 40 to 80 tons**

Tonnage	Model Number	Unit Wiring					Motor Data								
							Compressor (EA)						Fan (EA)		
		Nameplate Voltage	Voltage Range	MCA	MOP	Disc	Fixed Speed			Variable Speed		VSD			
Qty	RLA						LRA	Qty	Max Input (A)	Qty	kW	FLA			
40	SCWMN04LF	208-230/60/3	187 - 253	186.6	250	200	1	55.77	340	1	56	3	6.15	18.6	
	SCWMN040F	208-230/60/3	187-253	221.6	300	225	1	55.77	340	1	84	3	6.15	18.6	
	SCWMN04L4	460/60/3	414 - 506	90.7	125	100	1	23.72	110	1	30	3	6.15	9	
	SCWMN0404	460/60/3	414-506	128.2	200	125	1	23.72	110	1	60	3	6.15	9	
50	SCWMN05LF	208-230/60/3	187 - 253	233.4	300	250	2	51.28	300	1	56	3	6.15	18.6	
	SCWMN050F	208-230/60/3	187-253	268.4	350	300	2	51.28	300	1	84	3	6.15	18.6	
	SCWMN05L4	460/60/3	414 - 506	113.2	150	125	2	23.1	150	1	30	3	6.15	9	
	SCWMN0504	460/60/3	414-506	150.7	200	150	2	23.1	150	1	60	3	6.15	9	
60	SCWMN06LF	208-230/60/3	187 - 253	260.9	300	300	2	55.77	340	1	56	4	6.15	18.6	
	SCWMN060F	208-230/60/3	187-253	295.9	375	300	2	55.77	340	1	84	4	6.15	18.6	
	SCWMN06L4	460/60/3	414 - 506	123.4	150	150	2	23.72	110	1	30	4	6.15	9	
	SCWMN0604	460/60/3	414-506	160.9	225	175	2	23.72	110	1	60	4	6.15	9	
70	SCWMN07LF	208-230/60/3	187-253	321.8	375	350	3	51.28	300	1	56	5	6.15	18.6	
	SCWMN070F	208-230/60/3	187-253	356.9	450	375	3	51.28	300	1	84	5	6.15	18.6	
	SCWMN07L4	460/60/3	414-506	154.2	175	175	3	23.1	150	1	30	5	6.15	9	
	SCWMN0704	460/60/3	414-506	191.7	250	200	3	23.1	150	1	60	5	6.15	9	
80	SCWMN08LF	208-230/60/3	187-253	335.3	400	375	3	55.77	340	1	56	5	6.15	18.6	
	SCWMN080F	208-230/60/3	187-253	370.3	450	400	3	55.77	340	1	84	5	6.15	18.6	
	SCWMN08L4	460/60/3	414-506	156.2	175	175	3	23.72	110	1	30	5	6.15	9	
	SCWMN0804	460/60/3	414-506	193.7	250	200	3	23.72	110	1	60	5	6.15	9	

**Notes:**

1. MCA: Minimum Circuit Ampacity is 125% of the largest compressor RLA or Drive input current, plus 100% of the other compressor (s) RLA, plus the sum of the condenser fan RLA, plus any other load rated at 1 AMP or more.
2. Maximum Breaker Overcurrent Protection (MOP): 225% of the largest compressor RLA or VSD drive Input, plus 100% of the other compressor (s) RLA, plus the sum of the condenser fan Motor/Drive FLA, plus any other load rated at 1 AMP or more.
3. Recommended disconnect switch: 110% to 115% of the sum of the RLA of the compressors, VSD drive input, fan motor/drive and controls FLA.
4. RLA: Rated in accordance with UL standard 1995
5. Local codes may take precedence.
6. Fix speed compressor are across the line starting, the VSD compressors are controlled by VSD drive. Compressors will never start simultaneously.
7. Voltage utilization range is ±10 percent.

**Table 12. Electrical data – 40 to 80 tons**

Tonnage	Model Number	Nameplate Voltage	Compressor (EA)					Fan (EA)		
			Fixed Speed			Variable Speed		VSD		
			Qty	RLA	LRA	Qty	Max Input (A)	Qty	kW	FLA
40	SCWMN04LF	208-230/60/3	1	55.77	340	1	56	3	0.5	18.6
	SCWMN040F	208-230/60/3	1	55.77	340	1	84	3	6.15	18.6
	SCWMN04L4	460/60/3	1	23.72	110	1	30	3	0.5	9
	SCWMN0404	460/60/3	1	23.72	110	1	60	3	6.15	9
50	SCWMN05LF	208-230/60/3	2	51.28	300	1	56	3	0.5	18.6
	SCWMN050F	208-230/60/3	2	51.28	300	1	84	3	6.15	18.6
	SCWMN05L4	460/60/3	2	23.1	150	1	30	3	0.5	9
	SCWMN0504	460/60/3	2	23.1	150	1	60	3	6.15	9



## Electrical Data

**Table 12. Electrical data – 40 to 80 tons (continued)**

Tonnage	Model Number	Nameplate Voltage	Compressor (EA)				Fan (EA)			
			Fixed Speed			Variable Speed		VSD		
			Qty	RLA	LRA	Qty	Max Input (A)	Qty	kW	FLA
60	SCWMN06LF	208-230/60/3	2	55.77	340	1	56	4	0.5	18.6
	SCWMN060F	208-230/60/3	2	55.77	340	1	84	4	6.15	18.6
	SCWMN06L4	460/60/3	2	23.72	110	1	30	4	0.5	9
	SCWMN0604	460/60/3	2	23.72	110	1	60	4	6.15	9
70	SCWMN07LF	208-230/60/3	3	51.28	300	1	56	5	6.15	18.6
	SCWMN070F	208-230/60/3	3	51.28	300	1	84	5	6.15	18.6
	SCWMN07L4	460/60/3	3	23.1	150	1	30	5	6.15	9
	SCWMN0704	460/60/3	3	23.1	150	1	60	5	6.15	9
80	SCWMN08LF	208-230/60/3	3	55.77	340	1	56	5	6.15	18.6
	SCWMN080F	208-230/60/3	3	55.77	340	1	84	5	6.15	18.6
	SCWMN08L4	460/60/3	3	23.72	110	1	30	5	6.15	9
	SCWMN0804	460/60/3	3	23.72	110	1	60	5	6.15	9

**Table 13. Compressor electrical data – 40 to 80 tons**

Tonnage	Model Number	Nameplate Voltage	Compressor (EA)				
			Fixed Speed			Variable Speed	
			Qty	RLA	LRA	Qty	Max Input (A)
40	SCWMN04LF	208-230/60/3	1	55.77	340	1	56
	SCWMN040F	208-230/60/3	1	55.77	340	1	84
	SCWMN04L4	460/60/3	1	23.72	110	1	30
	SCWMN0404	460/60/3	1	23.72	110	1	60
50	SCWMN05LF	208-230/60/3	2	51.28	300	1	56
	SCWMN050F	208-230/60/3	2	51.28	300	1	84
	SCWMN05L4	460/60/3	2	23.1	150	1	30
	SCWMN0504	460/60/3	2	23.1	150	1	60
60	SCWMN06LF	208-230/60/3	2	55.77	340	1	56
	SCWMN060F	208-230/60/3	2	55.77	340	1	84
	SCWMN06L4	460/60/3	2	23.72	110	1	30
	SCWMN0604	460/60/3	2	23.72	110	1	60
70	SCWMN07LF	208-230/60/3	3	51.28	300	1	56
	SCWMN070F	208-230/60/3	3	51.28	300	1	84
	SCWMN07L4	460/60/3	3	23.1	150	1	30
	SCWMN0704	460/60/3	3	23.1	150	1	60
80	SCWMN08LF	208-230/60/3	3	55.77	340	1	56
	SCWMN080F	208-230/60/3	3	55.77	340	1	84
	SCWMN08L4	460/60/3	3	23.72	110	1	30
	SCWMN0804	460/60/3	3	23.72	110	1	60



**Table 14. Fan motor electrical data – 40 to 80 tons**

Tonnage	Model Number	Nameplate Voltage	Fan (EA) - VSD		
			Qty	kW	FLA
40	SCWMN04LF	208-230/60/3	3	6.15	18.6
	SCWMN040F	208-230/60/3	3	6.15	18.6
	SCWMN04L4	460/60/3	3	6.15	9
	SCWMN0404	460/60/3	3	6.15	9
50	SCWMN05LF	208-230/60/3	3	6.15	18.6
	SCWMN050F	208-230/60/3	3	6.15	18.6
	SCWMN05L4	460/60/3	3	6.15	9
	SCWMN0504	460/60/3	3	6.15	9
60	SCWMN06LF	208-230/60/3	4	6.15	18.6
	SCWMN060F	208-230/60/3	4	6.15	18.6
	SCWMN06L4	460/60/3	4	6.15	9
	SCWMN0604	460/60/3	4	6.15	9
70	SCWMN07LF	208-230/60/3	5	6.15	18.6
	SCWMN070F	208-230/60/3	5	6.15	18.6
	SCWMN07L4	460/60/3	5	6.15	9
	SCWMN0704	460/60/3	5	6.15	9
80	SCWMN08LF	208-230/60/3	5	6.15	18.6
	SCWMN080F	208-230/60/3	5	6.15	18.6
	SCWMN08L4	460/60/3	5	6.15	9
	SCWMN0804	460/60/3	5	6.15	9



# Dimensional Data

Figure 7. Unit dimensions (in inches)

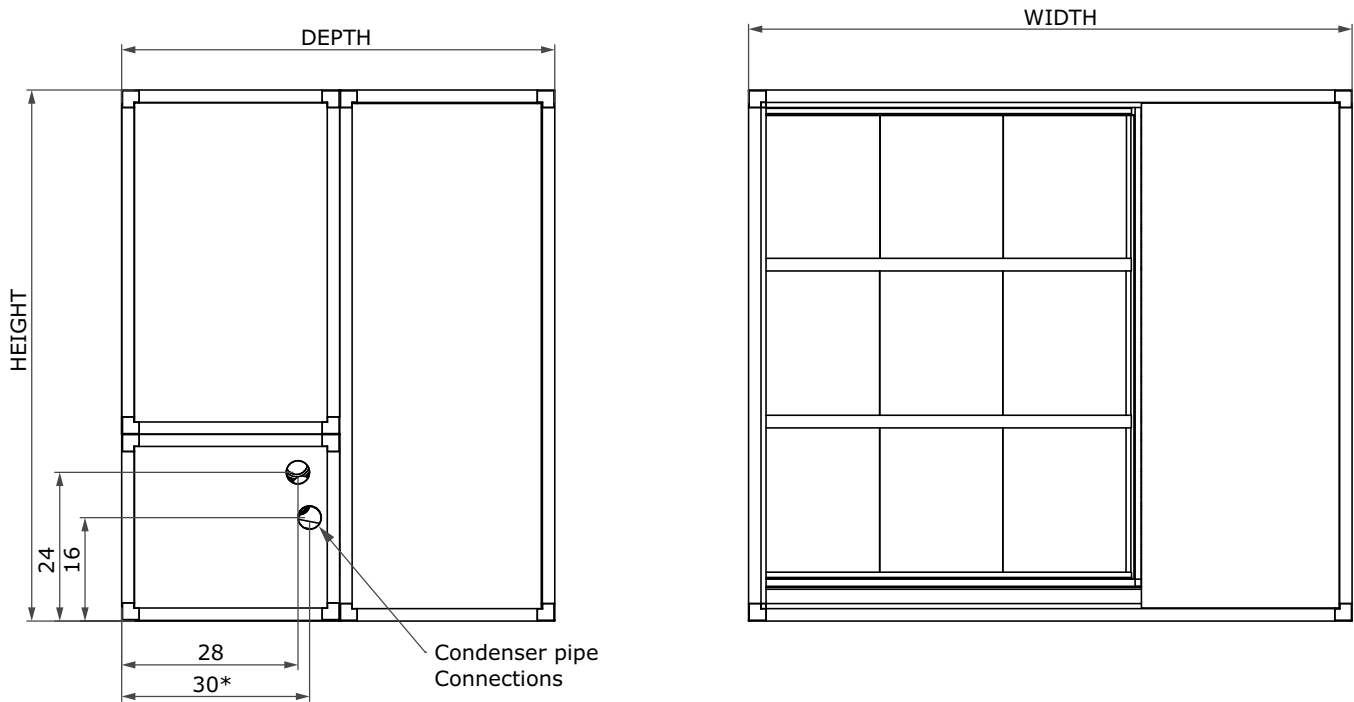
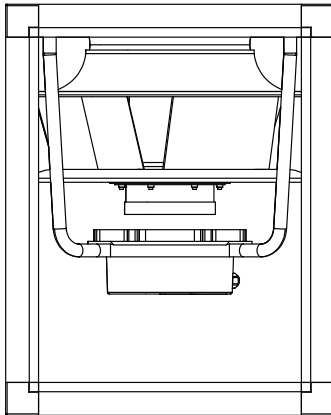

Table 15. Unit dimensions (in inches)

Model	Width	Height	Depth
40/40L	96 <sup>(a)</sup>	84	69
50/50L	96 <sup>(a)</sup>	84	69
60/60L	96 <sup>(a)</sup>	84	69
70/70L	127 <sup>(a)</sup>	84	69
80/80L	127 <sup>(a)</sup>	84	69

<sup>(a)</sup> Does not include condensate drain connection. Add an additional 1.5 inch to width to account for drain connection.

**Figure 8. Fan assembly footprint (in mm/inches)**

TOP VIEW

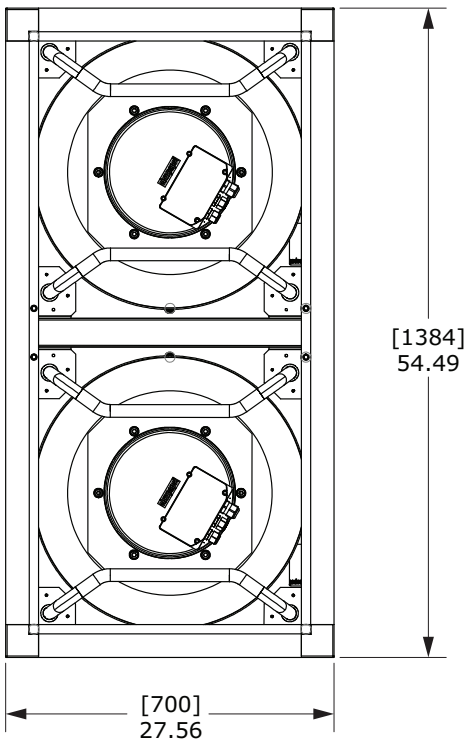

FRONT VIEW

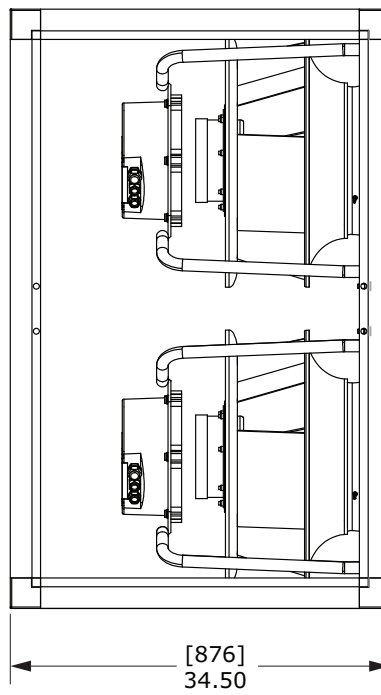

SIDE VIEW



## Dimensional Data

Figure 9. Variable speed compressor assembly footprint (in mm/inches)

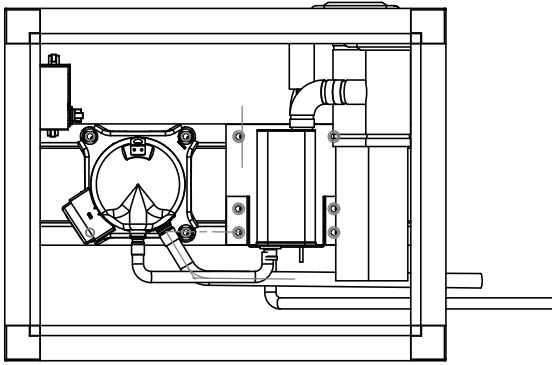

TOP VIEW

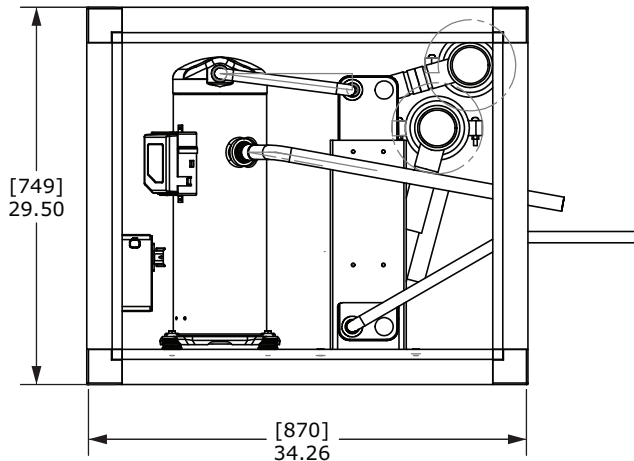

FRONT VIEW

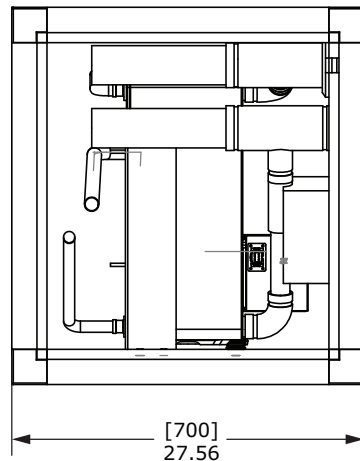

SIDE VIEW

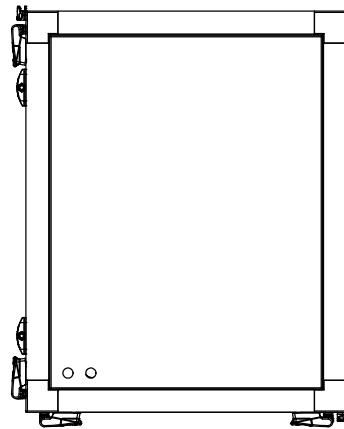
**Figure 10. Starter cassette assembly footprint (in inches)**

TOP VIEW

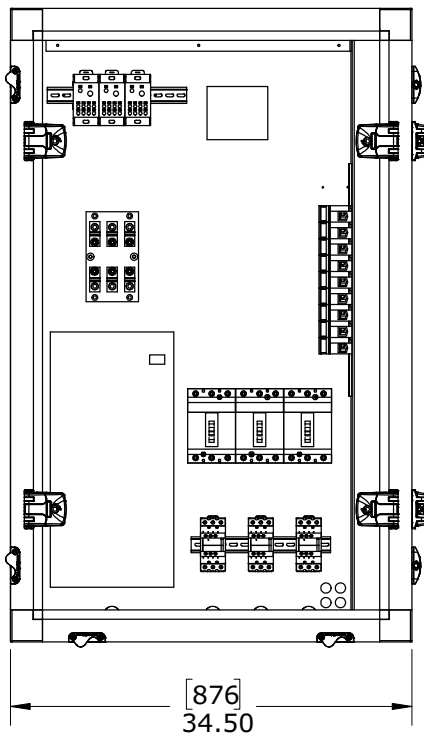

SIDE VIEW

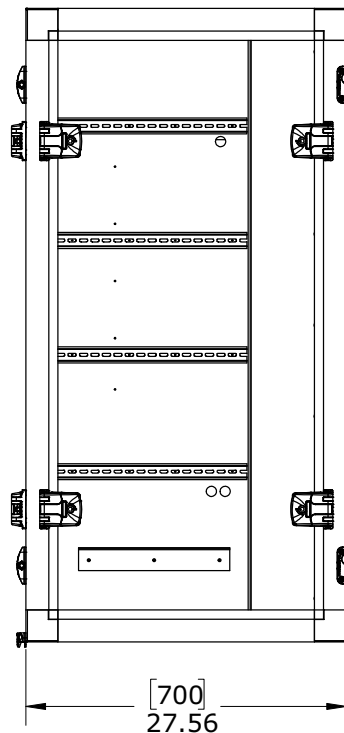

FRONT VIEW

## Dimensional Data

Figure 11. Evaporator cassette assembly footprint (in inches)

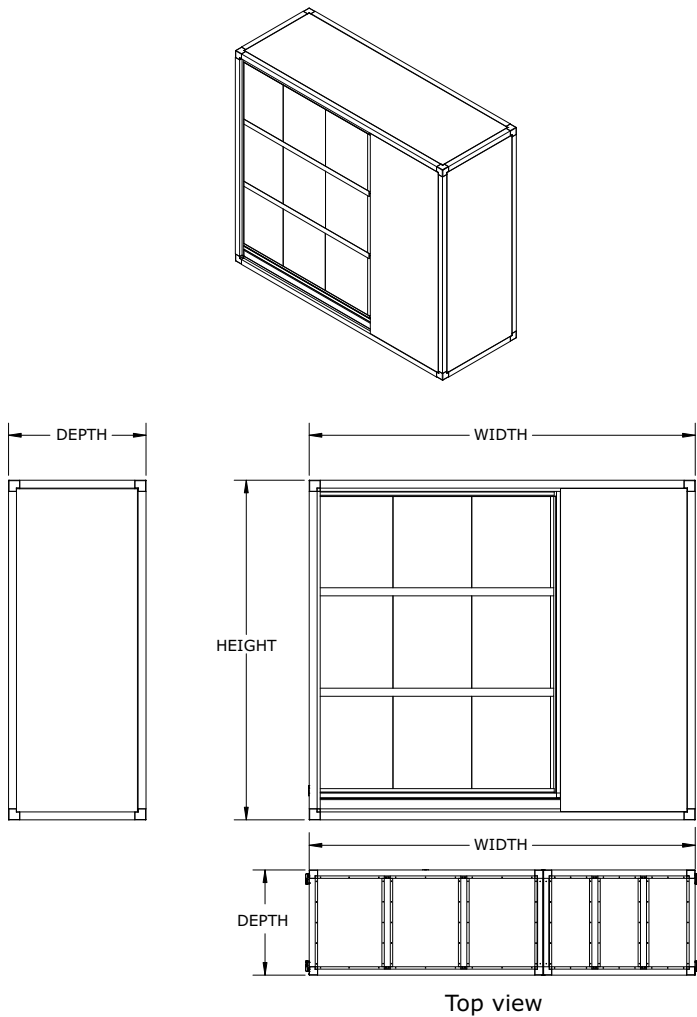

Table 16. Evaporator cassette dimensions (in inches)

Model	Width	Split Coil Width	Height	Depth
40/40L	96 <sup>(a)</sup>	N/A	84	34.5
50/50L	96 <sup>(a)</sup>	N/A	84	34.5
60/60L	96 <sup>(a)</sup>	N/A	84	34.5
70/70L <sup>(b)</sup>	127 <sup>(a)</sup>	77	84	34.5
		50	84	34.5
80/80L <sup>(b)</sup>	127 <sup>(a)</sup>	77	84	34.5
		50	84	34.5

<sup>(a)</sup> Does not include condensate drain connection. Add an additional 1.5 inch to width to account for drain connection.

<sup>(b)</sup> Split coils.

Figure 12. Discharge opening for 40-60 ton

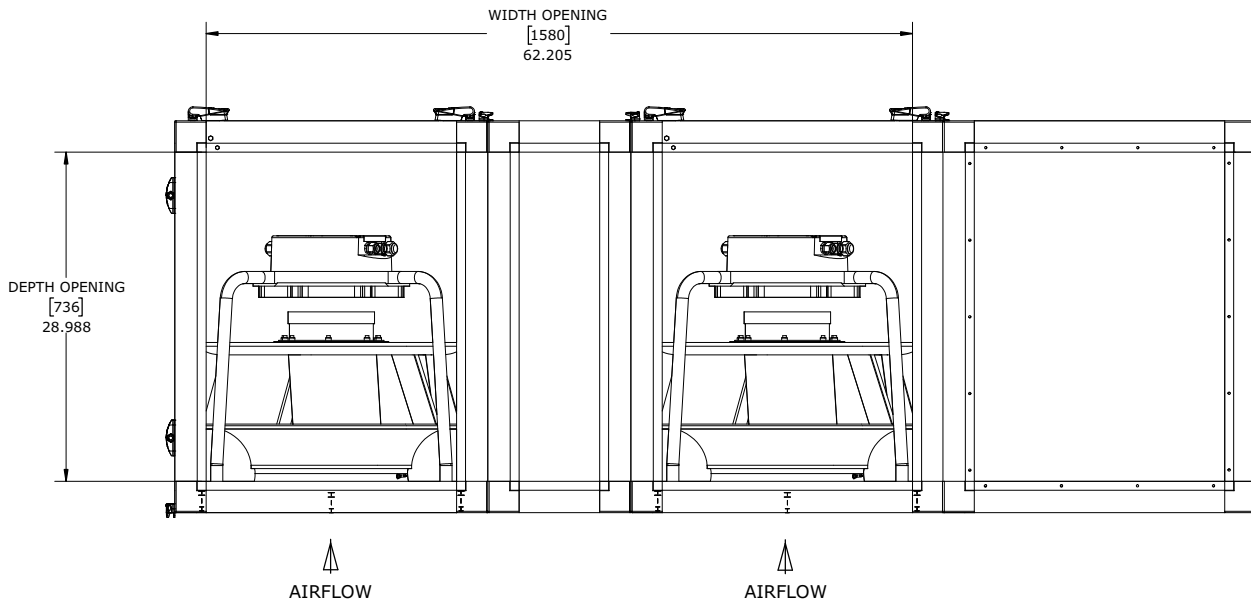
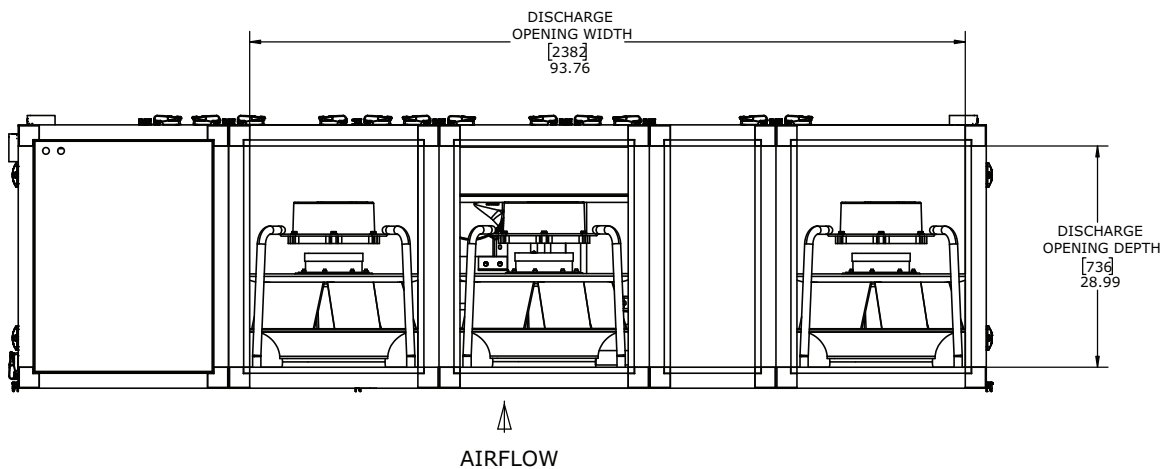

Figure 13. Discharge opening for 70-80 ton



## Service Clearances

Table 17. Service/code clearance requirements

Side		Distance - in. (mm)	Purpose
Front		42 (1066)	Fans, Compressors, Condensers, Refrigeration access
Left	Left Hand Starter	42 (1066)	NEC Code Requirement (Starter Panel)
	Right Hand Starter	9 (229)	
Right	Left Hand Starter	9 (229)	NEC Code Requirement (Starter Panel)
	Right Hand Starter	42 (1066)	
Inlet		18 (457)	Provides uniform air flow



# Weights

**Table 18. Unit weights**

Unit Size	Base Weight		Waterside Economizer	
	(lbs)	(kg)	(lbs)	(kg)
40 Ton	3041	1379	381	173
50 Ton	3506	1590	468	212
60 Ton	3641	1652	568	258
70 Ton	4733	2146	762	346
80 Ton	4733	2146	762	346

**Note:** All unit weights include refrigerant, water, and controllers.

**Table 19. Unit shipping weights (fan cassette)**

Unit Size	Overall Dimensions	Unit Weight (lbs)	Fan Cassette	Number of Dual	Fan Weight (Two Fans)	Number of Single	Fan Weight (Single Fan)	Total Fan Weight
40 Ton	70"x 84" x 95.5"	2933	34.5"x 54.5"x 27.6"	1	408	1	308	716
50 Ton	70"x 84" x 95.5"	3365	34.5"x 54.5"x 27.6"	1	408	1	308	716
60 Ton	70"x 84" x 95.5"	3500	34.5"x 54.5"x 27.6"	2	408	0	308	816
70 Ton	70"x 84" x 126"	4545	34.5"x 54.5"x 27.6"	2	408	1	308	1124
80 Ton	70"x 84" x 126"	4545	34.5"x 54.5"x 27.6"	2	408	1	308	1124

**Table 20. Unit shipping weights (compressor cassette)**

Unit Size	Overall Dimensions	Unit Weight (lbs)	Compressor Cassette	Number Fixed Spd	FS Condensing Unit Cassette	Number Var Spd	VS Condensing Unit Cassette	Total Condensing Unit Weight
40 Ton	70"x 84" x 95.5"	2933	34.5"x 29.5"x 27.6"	1	385	1	335	720
50 Ton	70"x 84" x 95.5"	3365	34.5"x 29.5"x 27.6"	2	385	1	335	1105
60 Ton	70"x 84" x 95.5"	3500	34.5"x 29.5"x 27.6"	2	385	1	335	1105
70 Ton	70"x 84" x 126"	4545	34.5"x 29.5"x 27.6"	3	385	1	335	1490
80 Ton	70"x 84" x 126"	4545	34.5"x 29.5"x 27.6"	3	385	1	335	1490

**Table 21. Unit shipping weights (starter cassette)**

Unit Size	Overall Dimensions	Unit Weight (lbs)	Starter Cassette	Starter Cassette Weight (230 Vac)
40 Ton	70"x 84" x 95.5"	2933	34.5"x 54.5"x 27.6"	323
50 Ton	70"x 84" x 95.5"	3365	34.5"x 54.5"x 27.6"	323
60 Ton	70"x 84" x 95.5"	3500	34.5"x 54.5"x 27.6"	323
70 Ton	70"x 84" x 126"	4545	34.5"x 54.5"x 27.6"	388
80 Ton	70"x 84" x 126"	4545	34.5"x 54.5"x 27.6"	388

**Table 22. Unit shipping weights (evaporator cassette)**

Tonnage	Overall dimensions	Unit Weight (lbs)	Evaporator Cassette	Total Weight of Cassette (excl. Economizer)
40 Ton	70"x 84" x 95.5"	2933	34.5" x 84" x 94"	1127
50 Ton	70"x 84" x 95.5"	3365	34.5" x 84" x 94"	1219
60 Ton	70"x 84" x 95.5"	3500	34.5" x 84" x 94"	1254



**Table 22. Unit shipping weights (evaporator cassette) (continued)**

<b>Tonnage</b>	<b>Overall dimensions</b>	<b>Unit Weight (lbs)</b>	<b>Evaporator Cassette</b>	<b>Total Weight of Cassette (excl. Economizer)</b>
70 Ton <sup>(a)</sup>	70"x 84" x 127"	4545	34.5" x 84" x 77"	1032
			34.5" x 84" x 50"	620
80 Ton <sup>(a)</sup>	70"x 84" x 127"	4545	34.5" x 84" x 77"	1032
			34.5" x 84" x 50"	620

<sup>(a)</sup> Split coils



# Mechanical Specifications

## Modular Series Self-Contained Units

*Notes: Certified DOE Performance:*

- Trane Commercial Self-Contained units are tested in accordance with AHRI 340/360 (I-P).
- The net cooling capacity and EER performance are certified to 10 CFR Part 431 from the US Department of Energy.

### Cabinet

- The unit framework are formed structural members of sturdy-gauge aluminium. Exterior panels are fabricated from 1-inch thick insulating foam core sandwiched between two layers of exterior grade cement and finished aluminum sheets.
- The unit is provided with removable panels to allow service access to compressors, condensers, fans, coils, and valves. Removable panels are secured with quick-acting hinges that allow panel to act as door, or completely remove panel when necessary. The refrigerant sight glasses are accessible during operation.

### Compressors

- Units have multiple compressors with independent circuits.
- Compressors are manufactured by an independent manufacturer.
- Scroll compressors are heavy duty suction cooled type with suction screen, centrifugal oil pump with dirt separator, oil charging valve, and oil sight glass.
- Protective devices for low pressure, high pressure, and motor temperature are provided.
- The compressors are mounted on isolators for vibration isolation.

### Phase and Voltage Monitor

- Protects 3-phase equipment from phase loss, phase reversal and low voltage.
- Any fault condition will produce a Failure Indicator LED and send the unit into an auto stop condition.
- cULus approved.

### Condenser

- One condenser is provided for each compressor.
- The condensers are brazed plate and are chemically cleanable. A 20 mesh removable screen is provided upstream of all condensers for additional protection. Pressure differential across the screen also alerts user if the screen needs to be cleaned.
- Condenser waterside working pressure is 400 psig.

### Evaporator

- Evaporator coils shall be UL recognized as Refrigerant Containing Component. Coils to be used with refrigerant R-410A shall have undergone cycle testing, and shall be safety listed with 750 psig rating.
- Tubes and return bends shall be constructed from seamless UNS C12200 copper conforming to ASTM B224 and ASTM E527. Properties shall be O50 light annealed, with a maximum grain size of 0.040 mm. Tubes are to be mechanically expanded into fins (secondary surface) for maximum heat transfer. Materials are to be 3/8-inch diameter x (0.014) wall thickness, copper rifled tubes.
- Secondary surface (fins) shall be of the plate-fin design using aluminum or copper, with die-formed collars. Fin design to be flat, waffle, or sine-wave in a staggered tube pattern to meet performance requirements. Collars will hold fin spacing at specified density, and cover the

entire tube surface. Aluminum properties are to be Alloy 1100 per ASTM B209, with O (soft) temper; copper is to be Alloy 11000 per ASTM B152-06 with soft (anneal) temper. Fins are to be free of oils and oxidation.

- Headers are to be constructed of seamless UNS C12200, Type L (drawn) copper material sized to match specified connection size.
- Evaporator coils shall be designed with brass liquid distributors (as required), and copper sweat suction connections. Distributors shall be capped using soft-solder for ease of cap removal; suction connections shall be capped.
- Coil casing material shall be of G90 galvanized steel, 12 gauge. Intermediate tube supports are to be provided on all coils 48" and longer fin length. Coil casings on top and bottom of coils are to have double-flange construction, allowing for vertical stacking of coils.
- All coils are to be brazed with minimum 5% silver content (BCup-3) filler material to insure joint integrity.
- Coils shall be certified to withstand 750 psig working pressures.

## Refrigerant Circuit

- Refrigerant circuits are independent and include sight glasses, distributors, thermal expansion valves with adjustable superheat and external equalizer, and high pressure relief valves with ½-inch (13 mm) flare connection.
- Unit is provided with adequate means of frost control.
- The circuits are shipped with a small nitrogen charge.
- Compressors are mounted on rubber-in-shear isolators for vibration isolation.

## Supply Fan

Direct drive plenum fans for increased efficiency. Plenum fans are equipped with integrated motor, electronics, and Variable Frequency drives (VFD) are tested in the factory and easy field wiring ensures quick, easy, and reliable startup.

## Filters

- Standard filters are 2-inch MERV 8 (24" x 20").
- Optional 4-inch and 6-inch available.

## Unit Controls—DDC

- Microprocessor controls are provided to control all unit functions. The control system provided is the Trane Tracer™ UC600 Controller. The controls are factory-installed and mounted in the main control panel. All factory-installed controls are fully commissioned (run tested) at the factory. The unit provides a unit-mounted Tracer TD7 user interface with a 7-inch WVGA 800 x 480 resolution touch-sensitive color screen. The screen is backlit, which enables viewing in poor light conditions. The TD7 display is standard to provide the operator with full adjustment and display of control data functions. The unit controls are used as a standalone controller or as part of a building management system involving multiple units.

The unit is equipped with a complete microprocessor control system. This system consists of temperature and pressure (thermistor and static pressure transducer) sensors, control modules and a unit mounted user interface panel. Modules are individually replaceable for service ease. All microprocessors, modules, and sensors are factory mounted, wired, and tested.

- Light emitting diodes (LEDs) indicate the operation and communication status of the controller.
- Zone sensors are available in several combinations with selectable features depending on sensor.
- The TD7 display supports 25 built-in languages.



## Mechanical Specifications

---

### Agency Listing

Units shall have the Intertek ETL agency listing.

## Modular Self-Contained Options

### Air Volume/Temperature Control

#### Supply Air Temperature Control With Variable Frequency Drive

This option controls the VAV self-contained unit from the discharge air temperature using factory-mounted, direct drive plenum fans with variable frequency drives (VFD). The VFD safely varies the fan motor speed to allow the motor to meet the dynamic requirements at the motor shaft and meet the system static. Other control components include a discharge air microprocessor controller and discharge air sensor. The microprocessor controller coordinates the optional waterside economizer control and the stages of cooling with optional discharge air temperature reset capabilities. The VFD receives 0-10 Vdc signal from the unit microprocessor based upon supply static pressure and causes the drive to accelerate or decelerate as required to maintain the supply static pressure setpoint.

### Waterside Economizer

The waterside economizer takes advantage of cooling tower water to either pre-cool the entering air to aid the mechanical cooling process or, provides total system cooling if the water temperature is low enough. Waterside economizing enables when the unit's entering water temperature is below the unit's entering mixed air temperature by a minimum of 4 °F plus the economizer's approach temperature. The approach temperature default is 4 °F and is adjustable from 0 to 9 °F. Waterside economizing disables when the unit's entering water temperature is not below the unit's entering mixed air temperature by at least the water economizer approach temperature. The economizer acts as the first stage of cooling. If the economizer is unable to maintain the supply air setpoint, the unit control module brings on compressors as required to meet the setpoint.

The waterside economizer includes a coil, modulating valves, controls, and piping with cleanouts. The coil construction is ½-inch (13 mm) OD seamless copper tubes expanded into aluminum fins. The evaporator and economizer coils share a common sloped (IAQ) drain pan. Drain pan options are either galvanized or stainless steel and insulated.

### Hot Water Coil (Hydronic)

The hot water heating assembly included the coil and filter section and is factory installed on the unit's inlet. Please note: if a Hot Water coil is requested in conjunction with a Water Side Economizer, the WSE will be installed in the same module as the evaporator, and the HWC will be in an additional cassette that will be bolted to the Evaporator Module. The HWC is constructed of 3/8-inch (10 mm) OD copper. The copper tubes are expanded into aluminum fins and not exceeding 13 fins per inch. The coil casing is galvanized steel. Supply and return water connections are copper MPT. All coils are equipped with a vent/drain on the supply and return side. Please note that all piping for HWC will be field piped.

### Unit Flow Control

Units equipped with water regulating valves can be configured at the TD7 for variable or constant water flow.

#### Constant Water Flow

Two-way modulating control shutoff valves are wired, controlled, and installed in the unit on each installed compressor. These valves are driven to their maximum value anytime the unit is powered up. The valves will spring return closed in the event of a power failure.

If the unit has the Waterside Economizer option, the Water Side Economizer Valves will modulate to maintain the Discharge Air Setpoint when active, and be fully closed when inactive. These valves always remain variable flow due to the Waterside economizer design.

### **Variable Water Flow**

Two-way modulating control shutoff valves are wired, controlled, and installed in the unit on each installed compressor. When the compressor is in operation the valves modulate to maintain the differential pressure across the compressor and also to maintain the head pressure below the design setpoint. The valve will be limited to stay between the factory set Minimum and maximum valve position.

When the compressor is not running the valve will be fully closed. The valves will spring return closed in the event of a power failure.

If the unit has the Waterside Economizer option, the Waterside Economizer Valves will modulate to maintain the Discharge Air Setpoint when active, and be fully closed when inactive.

### **Water Flow Switch**

A water flow switch is required to be installed in the condenser water pipe within the unit; it can be supplied from the factory as an option or it can be field-provided. Whenever the flow switch detects a water flow loss prior to or during mechanical cooling, compressor operation locks out and a diagnostic code displays. If water flow is restored, the compressor operation automatically restores.

### **Non-fused External Disconnect Switch Optional - Terminal Block is Standard**

The unit is supplied with an external disconnect switch that will be field mounted.

### **Protective Coating**

Coils— Three to five mL of protective coating is applied to the coil using a multiple dip-and-bake process displays a diagnostic. A manual reset is required at the unit. The high duct temperature can be adjusted at the thermostat.

### **Stainless Steel Drain Pan**

The drain pan is/are positively sloped, fabricated from 304L stainless steel, and insulated with 1/4-inch (6.35 mm) of 1-lb. (0.5 kg) density fiberglass.

### **Dirty Filter Sensor**

A factory installed pressure sensor senses the pressure differential across the filters. When the differential pressure exceeds 0.9-inches (23 mm) WG, contact closure occurs.

A field installed indicator device may be wired to relay terminals that indicate when filter service is required. Contacts are rated at 115 Vac and are powered by a field supplied transformer.

### **Generic Building Automation System Module (GBAS)**

The GBAS module is for use with a non-BACnet MSTP BMS systems. The module provides a binary input for demand limiting, four analog inputs for setpoint adjustment, and five relay outputs for diagnostic reporting. Inputs can use a potentiometer or 0-5 Vdc signal.

### **Air Fi® Wireless Communications Interface (WCI) — Field Installed**

Air Fi® Wireless Communications Interface—Provides wireless communication between the Tracer® SC, Tracer® Unit Controllers and BACnet Communication Interface (BCI) modules.



Notes

---



Trane - by Trane Technologies (NYSE: TT), a global innovator - creates comfortable, energy efficient indoor environments for commercial and residential applications. For more information, please visit [trane.com](http://trane.com) or [tranetechnologies.com](http://tranetechnologies.com).

Trane has a policy of continuous product and product data improvements and reserves the right to change design and specifications without notice. We are committed to using environmentally conscious print practices.

PKG-PRC024E-EN 31 Oct 2021  
Supersedes PKG-PRC024D-EN (July 2020)

©2021 Trane