



# Installation, Operation, and Maintenance

## **IntelliPak™ 2**

### Commercial Rooftop Air Conditioners



#### **⚠ SAFETY WARNING**

Only qualified personnel should install and service the equipment. The installation, starting up, and servicing of heating, ventilating, and air-conditioning equipment can be hazardous and requires specific knowledge and training. Improperly installed, adjusted or altered equipment by an unqualified person could result in death or serious injury. When working on the equipment, observe all precautions in the literature and on the tags, stickers, and labels that are attached to the equipment.

February 2023

**RT-SVX073A-EN**

**TRANE**  
TECHNOLOGIES™



# Introduction

Read this manual thoroughly before operating or servicing this unit.

## Warnings, Cautions, and Notices

Safety advisories appear throughout this manual as required. Your personal safety and the proper operation of this machine depend upon the strict observance of these precautions.

The three types of advisories are defined as follows:



Indicates a potentially hazardous situation which, if not avoided, could result in death or serious injury.



Indicates a potentially hazardous situation which, if not avoided, could result in minor or moderate injury. It could also be used to alert against unsafe practices.



Indicates a situation that could result in equipment or property-damage only accidents.

## Important Environmental Concerns

Scientific research has shown that certain man-made chemicals can affect the earth's naturally occurring stratospheric ozone layer when released to the atmosphere. In particular, several of the identified chemicals that may affect the ozone layer are refrigerants that contain Chlorine, Fluorine and Carbon (CFCs) and those containing Hydrogen, Chlorine, Fluorine and Carbon (HCFCs). Not all refrigerants containing these compounds have the same potential impact to the environment. Trane advocates the responsible handling of all refrigerants-including industry replacements for CFCs and HCFCs such as saturated or unsaturated HFCs and HCFCs.

## Important Responsible Refrigerant Practices

Trane believes that responsible refrigerant practices are important to the environment, our customers, and the air conditioning industry. All technicians who handle refrigerants must be certified according to local rules. For the USA, the Federal Clean Air Act (Section 608) sets forth the requirements for handling, reclaiming, recovering and recycling of certain refrigerants and the equipment that is used in these service procedures. In addition, some states or municipalities may have additional requirements that must also be adhered to for responsible management of refrigerants. Know the applicable laws and follow them.

### ⚠ WARNING

#### Proper Field Wiring and Grounding Required!

Failure to follow code could result in death or serious injury.

All field wiring **MUST** be performed by qualified personnel. Improperly installed and grounded field wiring poses **FIRE** and **ELECTROCUTION** hazards. To avoid these hazards, you **MUST** follow requirements for field wiring installation and grounding as described in **NEC** and your local/state/national electrical codes.

### ⚠ WARNING

#### Personal Protective Equipment (PPE) Required!

Failure to wear proper PPE for the job being undertaken could result in death or serious injury.

Technicians, in order to protect themselves from potential electrical, mechanical, and chemical hazards, **MUST** follow precautions in this manual and on the tags, stickers, and labels, as well as the instructions below:

- **Before installing/servicing this unit, technicians MUST put on all PPE required for the work being undertaken (Examples; cut resistant gloves/sleeves, butyl gloves, safety glasses, hard hat/bump cap, fall protection, electrical PPE and arc flash clothing). ALWAYS refer to appropriate Safety Data Sheets (SDS) and OSHA guidelines for proper PPE.**
- **When working with or around hazardous chemicals, ALWAYS refer to the appropriate SDS and OSHA/GHS (Global Harmonized System of Classification and Labelling of Chemicals) guidelines for information on allowable personal exposure levels, proper respiratory protection and handling instructions.**
- **If there is a risk of energized electrical contact, arc, or flash, technicians MUST put on all PPE in accordance with OSHA, NFPA 70E, or other country-specific requirements for arc flash protection, PRIOR to servicing the unit. NEVER PERFORM ANY SWITCHING, DISCONNECTING, OR VOLTAGE TESTING WITHOUT PROPER ELECTRICAL PPE AND ARC FLASH CLOTHING. ENSURE ELECTRICAL METERS AND EQUIPMENT ARE PROPERLY RATED FOR INTENDED VOLTAGE.**

**⚠ WARNING****Follow EHS Policies!**

Failure to follow instructions below could result in death or serious injury.

- **All Trane personnel must follow the company's Environmental, Health and Safety (EHS) policies when performing work such as hot work, electrical, fall protection, lockout/tagout, refrigerant handling, etc. Where local regulations are more stringent than these policies, those regulations supersede these policies.**
- **Non-Trane personnel should always follow local regulations.**

## Overview of Manual

**Note:** *This document is customer property and must be retained by the unit owner for use by maintenance personnel.*

This unit is equipped with Symbio 800 controls. Refer to the "Start-Up" and "Manual Override" procedures within this Installation, Operation, and Maintenance manual and the latest edition of the appropriate programming manual for Variable Air Volume (VAV), or Single Zone Variable Air Volume (SZVAV) applications before attempting to operate or service this equipment.

**Important:** *The procedures discussed in this manual should only be performed by qualified and experienced HVAC technicians.*

This booklet describes proper installation, start-up, operation, and maintenance procedures for 90 to 150 ton rooftop air conditioners designed for VAV or SZ VAV applications. By carefully reviewing the information within this manual and following the instructions, the risk of

improper operation and/or component damage will be minimized.

**Note:** *One copy of the appropriate service literature ships inside the control panel of each unit.*

It is important that periodic maintenance be performed to help assure trouble-free operation. Should equipment failure occur, contact a qualified service organization with qualified, experienced HVAC technicians to properly diagnose and repair this equipment.

**Important:** *DO NOT release refrigerant to the atmosphere!*

If adding or removing refrigerant is required, the service technician must comply with all federal, state, and local laws.

## Copyright

This document and the information in it are the property of Trane, and may not be used or reproduced in whole or in part without written permission. Trane reserves the right to revise this publication at any time, and to make changes to its content without obligation to notify any person of such revision or change.

## Trademarks

All trademarks referenced in this document are the trademarks of their respective owners.

## Factory Training

Factory training is available through Trane University™ to help you learn more about the operation and maintenance of your equipment. To learn about available training opportunities contact Trane University™.

Online: [www.trane.com/traneuniversity](http://www.trane.com/traneuniversity)

Phone: 855-803-3563

Email: [traneuniversity@trane.com](mailto:traneuniversity@trane.com)



# Table of Contents

Model Number Description .....	7	Roof Curb and Ductwork .....	25
General Information .....	10	Pitch Pocket Location .....	25
Unit Nameplate .....	10	Field Converting Horizontal Ductwork (Supply or Return) from Right to the Left Side .....	27
Compressor Nameplate .....	10	Unit Rigging and Placement .....	29
Gas Heat Nameplate .....	10	Air-Cooled Condensers—Two-Piece Unit Fit Up .....	33
Unit Description .....	10	Tubing and Wiring Connections .....	36
Ventilation Override Module .....	10	General Installation Requirements .....	38
High Pressure Limit Controls .....	10	Rigging the Unit .....	38
Morning Warm-Up—Zone Heat .....	10	Main Electrical Power .....	39
Compressor Motor Winding Thermostats .....	10	Field Installed Control Wiring .....	39
VZH Variable Speed Compressors .....	11	Electric Heat Units .....	39
Pre-Installation .....	12	Gas Heat .....	39
Unit Inspection .....	12	Hot Water Heat .....	39
Exterior Inspection .....	12	Steam Heat .....	39
Inspection for Concealed Damage .....	12	O/A Pressure Sensor and Tubing Installation .....	39
Repair .....	12	Condensate Drain Connections .....	39
Storage .....	12	Units with Gas Furnace .....	40
Unit Clearances .....	12	Removing Compressor Assembly Shipping Hardware .....	40
Unit Dimensions and Weight Information .....	12	Removing Supply and Exhaust Fan Shipping Channels .....	40
Installation Checklist .....	13	O/A Sensor and Tubing Installation .....	40
General Checklist (Applies to all units) .....	13	Gas Heat Units .....	42
Unit Rigging and Placement (Two-piece —addition to General Checklist) .....	13	General Coil Piping and Connection Recommendations .....	47
Electric Heat Units .....	13	Disconnect Switch with External Handle .....	50
Main Electrical Power Requirements .....	13	Electric Heat Units .....	51
Gas Heat Units .....	14	Main Unit Power Wiring .....	51
Hot Water Heat .....	14	Electrical Service Sizing .....	52
Steam Heat .....	14	Field Installed Control Wiring .....	57
O/A Pressure Sensor and Tubing Installation .....	14	Controls using 24 VAC .....	57
Energy Recovery Wheel .....	14	Controls using DC Analog Input/ Outputs .....	57
Dimensional Data .....	15	Constant Volume Zone Panel (BAYSENS108*) .....	58
Electrical Entry Details .....	20	Variable Air Volume System Controls .....	58
Minimum Required Clearance .....	21	Variable Air Volume System Controls .....	58
Weights .....	22	Stop/Off/Auto .....	58
Installation .....	25	Emergency Override .....	58

Ventilation Override Module (VOM).....	59	EXV Control (Electronic Expansion Valve) .....	81
Temperature vs. Resistance Coefficient .....	60	Economizing .....	82
Emergency Stop Input .....	60	Outdoor Air Damper Fault Detection and Diagnostics (FDD) .....	83
Occupied/Unoccupied Contacts .....	60	Dehumidification Control - Occupied .....	83
Unit Startup .....	62	Dehumidification Control - Unoccupied .....	84
Sequence of Operation .....	62	Heat Types .....	84
Stop/Off/Auto .....	62	Unoccupied Cooling .....	86
Power-Up Start Delay .....	62	Unoccupied Heating .....	86
Normal Unit Starting .....	62	External Fan Control .....	86
Rapid Restart Operation .....	62	Overrides .....	88
Occupancy .....	62	Heat/Cool Capacity Lockouts and Limits .....	91
Sensors .....	63	Filter Status .....	91
Heat Cool Mode Status .....	63	Startup the Unit .....	91
Operating Modes .....	64	Performance Data .....	97
Unit Sub-Modes .....	65	Supply Fan .....	97
Supply Fan Control .....	66	Airside Pressure Drop — Standard	
Supply Fan VFD Bypass Control .....	67	Evaporator Coil .....	99
Minimum Ventilation Control .....	68	Relief Fan .....	101
Relief Fan and Space Static Pressure Control .....	69	Return Fan .....	102
0-25% Motorized Outdoor Air Damper .....	70	Component Static Pressure Drops .....	104
Units Without a Return Air Damper .....	70	Pressure Curves .....	110
Units With Independent Return Air Damper Control .....	70	(60 Hz) Air-Cooled Condensers .....	110
Energy Recovery Wheel .....	70	(50 Hz) Air-Cooled Condensers .....	124
Energy Recovery Wheel Availability .....	72	Components .....	137
Energy Recovery Cooling .....	72	Economizer and Exhaust Air Damper Adjustment .....	137
Energy Recovery Heating .....	72	Standard Unit with Energy Recovery Wheel .....	140
Energy Wheel Frost Avoidance .....	72	Energy Recovery Wheel (ERW) .....	146
Energy Wheel Frost Avoidance w/ Preheat (Optional) .....	73	Compressor Startup .....	153
Energy Wheel Proving Status .....	73	Refrigerant Charging .....	154
Return Fan .....	73	Compressor Crankcase Heaters .....	155
Discharge Air Temperature Control .....	74	Compressor Operational Sounds .....	155
Multi Zone-VAV - Discharge Temperature Units .....	74	At Shutdown .....	155
Space Temperature Control .....	75	At Low Ambient Start-Up .....	155
Space Temperature Control Units .....	76	Variable Speed Compressors .....	155
Compressor Staging and Timers .....	77	Electronic Compressor Protection Module (CPM) .....	155
Compressor Protections .....	78	Expansion Valves .....	158
Hot Gas Bypass .....	81		



## Table of Contents

---

Measuring Superheat . . . . .	158	VZH Variable Speed Compressors . . . . .	178
Charging by Subcooling . . . . .	159	VFD Programming Parameters (Supply/Return/Exhaust Inverters) . . . . .	179
Measuring Subcooling . . . . .	159	eFlex™ Compressor VFD Programming Parameters . . . . .	183
Standard Ambient Units . . . . .	159	Monthly Maintenance . . . . .	184
Electric, Steam and Hot Water Start- Up . . . . .	159	Filters . . . . .	184
. . . . .	159	Cooling Season . . . . .	184
Gas Furnace Start-Up . . . . .	160	Heating Season . . . . .	185
. . . . .	160	Coil Cleaning . . . . .	186
2-stage and Modulating Gas Furnace . . . . .	160	Refrigerant Coils . . . . .	186
2-stage and Modulating Burner Setup . . . . .	161	Steam or Hot Water Coils . . . . .	186
Final Unit Checkout . . . . .	164	Microchannel Condenser Coil Repair and Replacement . . . . .	187
Multi-piece Unit – Trane Start-Up . . . . .	164	Final Process . . . . .	187
Trane Startup Checklist . . . . .	166	Unit Wiring Diagram Numbers . . . . .	189
Critical Control Parameters and Dry Bulb Changeover Map . . . . .	167	Warranty and Liability Clause . . . . .	190
Service and Maintenance . . . . .	169	COMMERCIAL EQUIPMENT - 20 TONS AND LARGER AND RELATED ACCESSORIES . . . . .	190
Fan Belt Adjustment . . . . .	175		
Scroll Compressor Replacement . . . . .	176		
Refrigeration System . . . . .	177		
CSHN/CSHL Compressors . . . . .	178		



# Model Number Description

## DIGIT 1: Unit Type

**S** = Self-Contained (Packaged Rooftop)

## Digit 2 — Unit Function

**E** = DX Cooling, Electric Heat  
**F** = DX Cooling, Natural Gas Heat  
**L** = DX Cooling, Hot Water Heat  
**S** = DX Cooling, Steam Heat  
**X** = DX Cooling, No Heat, Extended Casing

## Digit 3 — System Type

**E** = DX Cooling, Electric Heat

## Digit 4 — Development Sequence

**E** = DX Cooling, Electric Heat

## Digit 5, 6, 7 — Nominal Capacity

**090** = 90 Ton Air-Cooled  
**105** = 105 Ton Air-Cooled  
**120** = 120 Ton Air-Cooled  
**130** = 130 Ton Air-Cooled  
**150** = 150 Ton Air-Cooled

## Digit 8 — Voltage Selection

**4** = 460/60/3  
**5** = 575/60/3  
**C** = 380/50/3

## Digit 9 — Heating Capacity Selection

**0** = No Heat  
**1** = Electric heat 90/56 kW 60/50 Hz  
**2** = Electric heat 140/88 kW 60/50 Hz  
**3** = Electric heat 265/166 kW 60/50 Hz  
**4** = Electric Heat 300/188 kW 60/50 Hz  
**A** = Low Gas Heat — 2-stage  
**B** = Medium Gas Heat — 2-stage  
**C** = High Gas Heat — 2-stage  
**D** = Low Gas Heat — Modulating  
**E** = Medium Gas Heat — Modulating  
**F** = High Gas Heat — Modulating  
**G** = Low Heat - 1.0" (25mm) Valve  
**H** = Low Heat - 1.25" (32mm) Valve  
**J** = Low Heat - 1.5" (38mm) Valve  
**K** = Low Heat - 2.0" (50mm) Valve  
**L** = Low Heat - 2.50" (64mm) Valve  
**M** = Low Heat - 3.0" (76mm) Valve  
**N** = High Heat - 1.0" (25mm) Valve  
**P** = High Heat - 1.25" (32mm) Valve  
**Q** = High Heat - 1.5" (38mm) Valve  
**R** = High Heat - 2.0" (50mm) Valve  
**T** = High Heat - 2.50" (64mm) Valve  
**U** = High Heat - 3.0" (76mm) Valve

## DIGIT 10, 11 — Design Sequence

## DIGIT 12 — Unit Configuration Selection

**1** = One-Piece Unit w/o Blank Section  
**2** = One-Piece Unit w/4' Blank Section  
**3** = One-Piece Unit w/8' Blank Section  
**4** = Two-Piece Unit w/o Blank Section  
**5** = Two-Piece Unit w/4' Blank Section  
**6** = Two-Piece Unit w/8' Blank Section

## DIGIT 13 — Supply/Return Airflow Direction

**1** = Downflow Supply/Upflow Return  
**2** = Downflow Supply/Horiz End Return  
**3** = Downflow Supply/Horiz Right Return  
**4** = Right Side Horiz Supply/Upflow Return  
**5** = Right Side Horiz Supply/Horizontal End Return  
**6** = Right Side Horiz Supply/Horizontal Right Return

## DIGIT 14 — Supply Fan Options

**1** = Standard CFM Supply Fan Motor(s)  
**3** = Standard CFM Supply Fan - TEFC High EFF Motor(s)  
**4** = Low CFM Supply Fan Motor(s)  
**6** = Low CFM Supply Fan - TEFC High EFF Motor (s)  
**7** = Standard CFM Supply Fan - w/ Internal Shaft Grounding  
**9** = Standard CFM Supply Fan - TEFC Motor and internal SGR  
**A** = Low CFM Supply Fan - w/ Internal Shaft Grounding  
**C** = Low CFM Supply Fan - TEFC Motor and internal SGR  
**D** = High CFM Fan Motor(s) and Piezometer  
**E** = High CFM Fan - TEFC Motor(s) and Piezometer  
**F** = High CFM Fan - ODP with SGR Motor(s) and Piezometer  
**G** = High CFM Fan - TEFC with SGR Motor(s) and Piezometer  
**H** = Low CFM Fan Motor(s) and Piezometer  
**J** = Low CFM Fan - TEFC Motor(s) and Piezometer  
**L** = Low CFM Fan - ODP with SGR Motor(s) and Piezometer  
**M** = Low CFM Fan - TEFC with SGR Motor(s) and Piezometer

## DIGIT 15 — Supply Fan Motor Selection

**F** = 15 hp  
**G** = 20 Hp  
**H** = 25 Hp  
**J** = 30 Hp  
**K** = 40 Hp  
**L** = 50 Hp  
**M** = 60 Hp  
**N** = 75 Hp  
**P** = 100 Hp

## DIGIT 16 — Supply Fan RPM Selection

**7** = 700  
**8** = 800  
**9** = 900  
**A** = 1000  
**B** = 1100  
**C** = 1200  
**D** = 1300  
**E** = 1400  
**F** = 1500  
**G** = 1600  
**H** = 1700  
**J** = 1800  
**K** = 1900  
**L** = 2000

## DIGIT 17 — Relief/Return Fan Options

**0** = None  
**5** = Std CFM Exhaust w/ VFD w/Bypass  
**6** = Low CFM Exhaust w/ VFD w/Bypass  
**7** = Std CFM Exhaust w/ VFD w/o Bypass  
**8** = Low CFM Exhaust w/ VFD w/o Bypass  
**C** = Std CFM Return w/ VFD w/ Bypass  
**D** = Low CFM Return w/ VFD w/ Bypass  
**E** = Std CFM Return w/ VFD w/o Bypass  
**F** = Low CFM Return w/ VFD w/o Bypass  
**G** = Std CFM Exhaust w/ VFD w/Bypass & Piezometer  
**H** = Low CFM Exhaust w/ VFD w/Bypass & Piezometer  
**J** = Std CFM Exhaust w/ VFD w/o Bypass & Piezometer  
**K** = Low CFM Exhaust w/ VFD w/o Bypass & Piezometer  
**L** = Std CFM Return w/ VFD w/ Bypass & Piezometer  
**M** = Low CFM Return w/ VFD w/ Bypass & Piezometer  
**N** = Std CFM Return w/ VFD w/o Bypass & Piezometer  
**P** = Low CFM Return w/ VFD w/o Bypass & Piezometer



## Model Number Description

### DIGIT 18 — Relief/Return Fan Motor Selection

0 = None  
D = 7.5 Hp  
E = 10 Hp  
F = 15 Hp  
G = 20 Hp  
H = 25 Hp  
J = 30 Hp  
K = 40 Hp  
L = 50 Hp  
M = 60 Hp

### DIGIT 19 — Relief/Return RPM Selection

0 = None  
3 = 300  
4 = 400  
5 = 500  
6 = 600  
7 = 700  
8 = 800  
9 = 900  
A = 1000  
B = 1100  
C = 1200  
D = 1300  
E = 1400

### DIGIT 20 — System Control Selection

4 = VAV (Discharge Temp Control) w/ VFD Supply  
5 = VAV(Discharge Temp Control) w/ VFD Supply w/ Bypass  
6 = VAV ( Single Zone) w/VFD Supply  
7 = VAV( Single Zone) w/VFD w/ Bypass

### DIGIT 21 — Fresh Air Options/Controls

A = 0-25% Motorized Damper  
B = Economizer w/ Dry Bulb  
C = Economizer w/ Reference Enthalpy  
D = Economizer w/ Comparative Enthalpy  
E = Econ w/ Fresh Air Measure/Dry Bulb  
F = Econ w/ Fresh Air Measure/Ref Enthalpy  
G = Econ w/ Fresh Air Measure/Comp Enthalpy  
H = Econ w/ DCV/Dry Bulb<sup>(a)</sup>  
J = Econ w/ DCV/Ref Enthalpy<sup>(a)</sup>  
K = Econ w/ DCV/Comp Enthalpy<sup>(a)</sup>  
L = Econ w/ Differential Dry Bulb  
M = Econ w/ DVC/Differentail Dry Bulb<sup>(a)</sup>  
N = Econ w/ Fresh Air Measure/DVC/Differerentail Dry Bulb<sup>(a)</sup>

### DIGIT 22 — Damper Option

0 = Standard  
1 = Low Leak Damper(s)-AMCA Class 2, 10cfm/ft<sup>2</sup>  
2 = Ultra Low Leak Damper(s)-AMCA Class 1, 4cfm/ft<sup>2</sup>  
3 = Ultra Low Leak, AMCA 1A, Title 24

### DIGIT 23— Pre-Evaporator Coil Filter Selection

0 = Pre-Evap Filters-MERV 8, High Eff Filters  
1 = Pre-Evap Filters-2" Rack/Less Filters  
2 = Pre-Evap Filters-MERV 15 Bag Filters w/ Prefilters  
3 = Pre-Evap Filters - Bag Filter Rack/Less Filters  
4 = Pre-Evap Filters - MERV 14 Cartridge Filters w/ Prefilters  
5 = Pre-Evap Filters - Cartridge Rack/Less Filters  
6 = Pre-Evap Filters - MERV 14 Low PD Cartridge w/Prefilters  
7 = Pre-Evap Filters - Low PD Cartridge Rack/Less Filters

### DIGIT 24 — Blank Section Application

#### Options

0 = None  
A = Final MERV 15 Bag Filters w/ Prefilters  
B = Final MERV 14 Low PD Cartridge Filters w/ Prefilters  
C = Final MERV 14 , Cartridge Filters w/ Prefilters  
D = Final MERV 14 High Temp Cartridge Filters w/ Prefilters  
E = Final MERV 17 HEPA Filters w/ Prefilters  
F = Final MERV 17 High Temp HEPA Filters w/ Prefilters

### DIGIT 25 — Energy Recovery Wheel

0 = None  
1 = Low CFM ERW w/ Bypass Defrost  
2 = Standard CFM ERW w/ Bypass Defrost

### DIGIT 26 — Unit Mounted Power Connection Selection

A = Terminal Block  
B = Non-Fused Disconnect  
C = Non-Fused Disconnect w/ Powered Convenience Outlet  
D = Unit Disconnect Switch w/ high fault SCCR  
E = Unit Disconnect Switch w/ high fault SCCR/ Powered Convenience Outlet

### DIGIT 27 — Condenser Coil Selection

0 =All Aluminum Air-Cooled Condenser Coil  
J = Corrosion Protected Condenser Coil

### DIGIT 28 — Efficiency, Capacity, and Drain Pan Option

A = Standard Evap Coil w/ Stainless Steel Drain Pan  
C = High Cap Evap Coil w/ Stainless Steel Drain Pan  
W = eFlex™ w/ Std evap coil w/ SS drain pan  
Z = eFlex™ w/ Hi cap evap coil w/ SS drain pan

### DIGIT 29 — Refrigeration System A

0 = Standard  
A = Suction Service Valves  
B = Replaceable Core Liquid Filter Driers  
C = Suction Service Valves and Replaceable Core Liquid Filter Driers

### DIGIT 30 — Refrigeration System B

0 = Standard  
1 = Modulating Hot Gas Reheat  
2 = Hot Gas Bypass  
3 = Modulating Hot Gas Reheat /Hot Gas By-Pass

### DIGIT 31 — Ambient Control Option

0 = Standard Ambient  
1 = Low Ambient

### DIGIT 32 — Controls

0 = None  
1 = Expansion Module  
2 = Power Meter  
3 = Expansion Module w/ Power Meter

### DIGIT 33 — Controls (continued)

0 = None  
3 = Rapid Restart  
4 = Filter Monitoring  
5 = Rapid Restart w/ Filter Monitoring

(a) Requires CO<sub>2</sub> Sensor(s)



**DIGIT 34 — Module Options**

0 = None  
1 = Modbus®  
2 = Modbus® and Ventilation Override  
3 = Air-Fi  
4 = Air-Fi and Ventilation Override  
D = Ventilation Override  
F = LonTalk®  
L = LonTalk® and Ventilation Override  
M = BACnet®  
N = BACnet® and Ventilation Override  
W = BACnet® with Air-Fi  
Z = BACnet® Interface and Ventilation Override

**DIGIT 35 — Zone Sensor Option**

0 = No Accessory Panel  
A = BAYSENS108 - Dual Setpoint w/Man/Auto  
Changover  
C = BAYSENS073 - Room Sensor w/ Timed  
Override & Cancel  
D = BAYSENS074 - Room Snsr w/ TO & Cancel &  
Local Stpt Adj  
M = BAYSENS800 - Programable Zone Sensor

**DIGIT 36 — Agency Approval Option**

0 = None  
1 = cULus

**DIGIT 37 — Service Enhancements**

0 = Single Side Access Door  
A = Dual Side Access Door  
B = Single Side Access Doors/ Marine Lights  
C = Dual Side Access Doors/ Marine Lights

**DIGIT 38 — Miscellaneous Options**

0 = None  
1 = Belt Guards  
2 = Burglar Bars  
3 = Belt Guards/Burglar Bars  
4 = Isolation Damper Control  
5 = Belt Guards/Isolation Damper Control  
6 = Burglar Bars/Isolation Damper Control  
7 = Belt Guards/Burglar Bars/Isolation Damper  
Control



# General Information

## Unit Nameplate

One Mylar unit nameplate is located on the outside of enclosure. It includes the unit model number, serial number, electrical characteristics, refrigerant charge, unit wiring diagram numbers, as well as other pertinent unit data. A small metal nameplate with the Model Number, Serial Number, and Unit Weight is located just above the Mylar nameplate, and a third nameplate is located on the inside of the control panel door.

## Compressor Nameplate

The Nameplate for the Scroll Compressor is located on the compressor lower housing. Max amps is listed on the nameplate and is the absolute highest amp load on the compressor at any operating condition (does not include locked rotor amps or inrush). This value should never be exceeded.

## Gas Heat Nameplate

The nameplate for the Gas Heater is located on the inside of the gas heat enclosure. Allowable operating values of Min and Max input rate, manifold pressure, and air rise for the heater is listed on the nameplate.

## Unit Description

Table 1. Available tonnages

Air Cooled Tonnages
90
105
120
130
150

Each one-piece rooftop air conditioner ships fully assembled from the factory. An optional roof curb, specifically designed for the S\_HN units is available from Trane. The roof curb kit must be field assembled and installed according to the latest edition of the roof curb installation manual.

Trane Commercial Rooftop Units are controlled by a Symbio™ 800 control system that consists of a network of modules and are referred to as Low Level Intelligent Devices (LLID). The acronym (LLID) is used extensively throughout this document when referring to the control system network. These modules through Proportional/Integral control algorithms perform specific unit functions which provide the best possible comfort level for the customer.

They are mounted in the control panel and are factory wired to their respective internal components. They receive

and interpret information from other unit modules, sensors, remote panels, and customer binary contacts to satisfy the applicable request for economizing, mechanical cooling, heating, and ventilation. Refer to the following discussion for an explanation of each module function.

**Note:** *The Symbio™ 800 coin cell tray should never be taken out unless the Symbio 800 is powered on or the Symbio 800 needs to be powered on shortly after replacing the battery. Failure to do this may shorten the battery life.*

## Ventilation Override Module

IKF12

The Ventilation Override module initiates specified functions such as; space pressurization, exhaust, purge, purge with duct pressure control, and unit off when any one of the five (5) binary inputs to the module are activated. The compressors and condenser fans are disabled during the ventilation operation. If more than one ventilation sequence is activated, the one with the highest priority is initiated.

## High Pressure Limit Controls

High Pressure controls are located on the discharge lines near the scroll compressors. They are designed to open when the discharge pressure approaches 650 ± 10 psig. The controls reset automatically when the discharge pressure decreases to approximately 550 ± 10 psig. However, the compressors on that circuit are locked out and a manual reset diagnostic is initiated after the fourth occurrence of a high pressure condition.

## Morning Warm-Up—Zone Heat

When a system changes from an unoccupied to an occupied mode, or switches from STOPPED to AUTO, or power is applied to a unit with the MWU option, the heater in the unit or external heat will be brought on if the space temperature is below the MWU setpoint. The heat will remain on until the temperature reaches the MWU setpoint.

If the unit is VAV, then the VAV box/unocc relay will continue to stay in the unoccupied position and the VFD output will stay at 100% during the MWU mode. When the MWU setpoint is reached and the heat mode is terminated, then the VAV box/unocc relay will switch to the occupied mode and the VFD output will be controlled by the duct static pressure. During Full Capacity MWU the economizer damper is held closed for as long as it takes to reach setpoint. During Cycling Capacity MWU the economizer damper is allowed to go to minimum position after one hour of operation if setpoint has not been reached.

## Compressor Motor Winding Thermostats

A thermostat is embedded in the motor windings of each Scroll compressor. Each thermostat is designed to open if the motor windings exceed approximately 221°F. The thermostat will reset automatically when the winding

temperature decreases to approximately 181°F. Rapid cycling, loss of charge, abnormally high suction temperatures, or the compressor running backwards could cause the thermostat to open. During a request for compressor operation, if the Compressor Module detects a problem outside of normal parameters, it turns any operating compressor(s) on that circuit "Off", locks out all compressor operation for that circuit, and initiates a manual reset diagnostic (compressor trip). These compressors

come equipped with a protection module that monitors phase loss, phase sequencing and motor temperature.

### **VZH Variable Speed Compressors**

Over current and over torque protection for VZH compressors are provided by the TRV200 inverter. VZH over temperature protection is not required.



# Pre-Installation

## Unit Inspection

To protect against loss due to damage incurred in transit, perform inspection immediately upon receipt of the unit.

### Exterior Inspection

If the job site inspection reveals damage or material shortages, file a claim with the carrier immediately. Specify the type and extent of the damage on the bill of lading before signing. Notify the appropriate sales representative.

**Important:** Do not proceed with installation of a damaged unit without sales representative's approval.

- Visually inspect the complete exterior for signs of shipping damages to unit or packing material.
- Verify that the nameplate data matches the sales order and bill of lading.
- Verify that the unit is properly equipped and there are no material shortages.
- Verify that the power supply complies with the unit nameplate and electric heater specifications.

### Inspection for Concealed Damage

Visually inspect the components for concealed damage as soon as possible after delivery and before it is stored.

Do NOT walk on the sheet metal base pans. Bridging between the unit's main supports may consist of multiple 2 by 12 boards or sheet metal grating.

**⚠ WARNING**

**No Step Surface!**  
 Failure to follow instruction below could result in death or serious injury.  
 Do not walk on the sheet metal drain pan. Walking on the drain pan could cause the supporting metal to collapse and result in the operator/technician falling.

If concealed damage is discovered:

- Notify the carrier's terminal of the damage immediately by phone and by mail.
- Concealed damage must be reported within 15 days.
- Request an immediate, joint inspection of the damage with the carrier and consignee.
- Stop unpacking the unit.
- Do not remove damaged material from receiving location.
- Take photos of the damage, if possible.
- The owner must provide reasonable evidence that the damage did not occur after delivery.

## Repair

Notify the appropriate sales representative before arranging unit installation or repair.

**Important:** Do not repair unit until the damage has been inspected by the carrier's representative.

## Storage

Store unit in a level and dry location. Use adequate blocking under the base rail. If unit is not level and supported adequately, damage may occur when removing screws and opening doors.

Take precautions to prevent condensate formation inside the unit electrical components and motors when:

- The unit is stored before it is installed; or,
- The unit is set on the roof curb and temporary auxiliary heat is provided in the building.

Isolate all side panel service entrances and base pan openings (e.g., conduit holes, S/A and R/A openings, and flue openings) to minimize ambient air from entering the unit until it is ready for startup.

**Note:** Do not use the unit heater as temporary heat without completing the startup procedures detailed under Startup information.

The manufacturer will not assume responsibility for equipment damage resulting from accumulation of condensate on the unit electrical and/or mechanical components.

## Unit Clearances

Minimum Required Clearance (see Dimensional Data chapter) illustrates the minimum operating and service clearances for either a single or multiple unit installation.

These clearances are the minimum distances necessary for adequate service, cataloged unit capacity, and peak operating efficiency. Providing less than the recommended clearances may result in condenser coil starvation, "short-circulating" of relief and economizer airflows, or recirculation of hot condenser air.

## Unit Dimensions and Weight Information

Description	Reference
<b>Air-Cooled Condenser</b>	
One-piece unit dimensions	See "Dimensional Data," p. 15
Two-piece unit dimensions	See "Dimensional Data," p. 15
Roof curb weights	See "Weights," p. 22

## Installation Checklist

### General Checklist (Applies to all units)

The checklist listed below is a summary of the steps required to successfully install a Commercial rooftop unit. This checklist is intended to acquaint the installing personnel with what is required in the installation process. It does not replace the detailed instructions called out in the applicable sections of this manual.

**Important:** *This checklist does not replace the detailed instructions called out in the applicable sections of this manual.*

- Unit checked for shipping damage and material shortage.
- Verify that the installation location of the unit will provide the required clearance for proper operation.
- Roof curb assembled and installed.
- Roof curb level and square.
- Ductwork secured to curb, or unit.
- Corners of duct adapters sealed on units with horizontal supply or return.
- Horizontal supply or return ductwork is self supporting.
- Pitch pocket installed for units with power supply through building roof.
- Unit set on curb and checked level.
- Unit-to-curb seal checked to ensure it is tight and without buckles or cracks.
- For 120-150 T units remove foam shipping blocks from evaporator suction headers to allow proper condensate drainage.
- Condensate drain lines installed to each evaporator drain connection.
- Verify that all access doors open 100% and are not obstructed by drain lines etc.
- Shipping hardware removed from each compressor assembly.
- Shipping hold-down bolts and shipping channels removed from the supply and relief/return fans with spring isolators.
- Supply and relief/return fans spring isolators checked for proper adjustment.
- Plastic coverings (paint shields) removed from all compressors (if present).
- Verify all discharge and suction line service valves are back seated.
- Compressor crankcase heaters energized for a minimum of 12 hours prior to unit refrigeration system start-up.
- Verify that unit literature (IOM, PTG) are left inside control box for start-up.

### Unit Rigging and Placement (Two-piece—addition to General Checklist)

- First, rig and set the low side unit on the roof curb (aligned with return end).
- Remove the rail connector splice brackets and install the brackets on the low side unit base rails.
- Take off the side panels (these are labeled) and the top cover of the high side unit and set aside to be assembled later.
- Rig and set the high side unit on roof curb pedestal.
- Lift the unit and position it over the pedestal.
- Use the rail splice bracket as an alignment aid to connect the Low and high side units. The Low and high side unit rails should be butted together with a maximum 2" (preferably 1") separation.
- Remove the left upper and lower louvered panels of the high side unit as well as the corner panels on each side to aid in tubing and wiring connections.
- Close refrigeration shut off valves as indicated in this manual—Liquid, discharge, hot gas bypass (if present), and hot gas reheat (if present).
- For 2 piece Air-Cooled condensers add field charge per nameplate.
- Braze refrigerant piping connections and leak test.
- Low side and high side evacuated to 500 microns.
- Standing vacuum does not rise over 200 microns in 15 minutes.
- Open service valves to allow refrigerant flow.
- Refrigerant released from discharge to suction until suction pressure is approximately 60 PSIG.
- Power wires connected in connection box.
- Control wires connected in connection box.
- Seal air gaps around wiring and refrigerant tubing through bulkhead.
- Side panels and top cover assembled between high and low side.
- Verify line dampening weights are installed on each discharge line.

### Electric Heat Units

- Inspect the heater junction box and control panel; tighten any loose connections.
- Check electric heat circuits for continuity.
- Two piece units only: Route power wiring to high side junction box.

### Main Electrical Power Requirements

- Verify that the power supply to the unit complies with the unit nameplate specification. Refer to Main Unit Power Wiring in the Installation chapter.
- Properly ground the unit.



## Pre-Installation

---

- Inspect all control panel components and tighten any loose connections.
- Connect properly sized and protected power supply wiring to a field supplied/installed disconnect and the unit (copper wiring only to the unit).
- Verify that phasing to the unit is correct (ABC).
- Turn the 1S1 fused switch inside the control panel off to prevent accidental unit operation. Turn the 1S20 fused switch inside the control panel on to power the crankcase heaters.
- Turn on power to the unit.
- Verify that the controls remain powered off.
- Verify that all compressor crankcase heaters are energized for at least eight hours prior to unit start-up.

**Important:** All field-installed wiring must comply with NEC and applicable local codes.

### Gas Heat Units

- Gas supply line properly sized and connected to the unit gas train.
- All gas piping joints properly sealed.
- Drip leg installed in the gas piping near the unit.
- Gas piping leak checked with a soap solution. If piping connections to the unit are complete, do not pressurize piping in excess of 0.50 psig or 14" W.C. to prevent component failure.
- Main supply gas pressure between 7" and 14" W.C.
- Flue Tubes clear of any obstructions.
- Factory-supplied flue assembly installed on the unit.
- Connect the 3/4" CPVC furnace drain stub-out to a proper condensate drain.
- Install field provided heat tape to furnace drain line.

### Hot Water Heat

- Route properly sized water piping through the base of the unit into the heating section.

- Install the factory-supplied, 3-way modulating valve.
- Complete the valve actuator wiring.

### Steam Heat

- Route properly sized steam piping through the base of the unit into the heating section.
- Install the factory-supplied, 2-way modulating valve.
- Complete the valve actuator wiring.
- Install 1/2", 15-degree swing check vacuum breaker(s) at the top of each coil section. Vent breaker(s) to the atmosphere or merge with return main at discharge side of steam trap.
- Position the steam trap discharge at least 12" below the outlet connection on the coil.
- Use float and thermostatic traps in the system, as required by the application.

### O/A Pressure Sensor and Tubing Installation

- O/A pressure sensor mounted to the roof bracket.
- Factory supplied pneumatic tubing installed between the O/A pressure sensor and the connector on the base rail.
- (Units with Relief/Return fans)Field supplied pneumatic tubing connected to the proper fitting on the space pressure transducer located in the return control panel, and the other end routed to a suitable sensing location within the controlled space.

### Energy Recovery Wheel

- Verify that the wheel turns freely through a full rotation.
- Confirm that all wheel segments are fully engaged in the wheel frame and that the segment retainers are completely fastened.
- Confirm the seal adjustment and proper belt tracking on the wheel rim.



# Dimensional Data

Figure 1. Unit top/left view

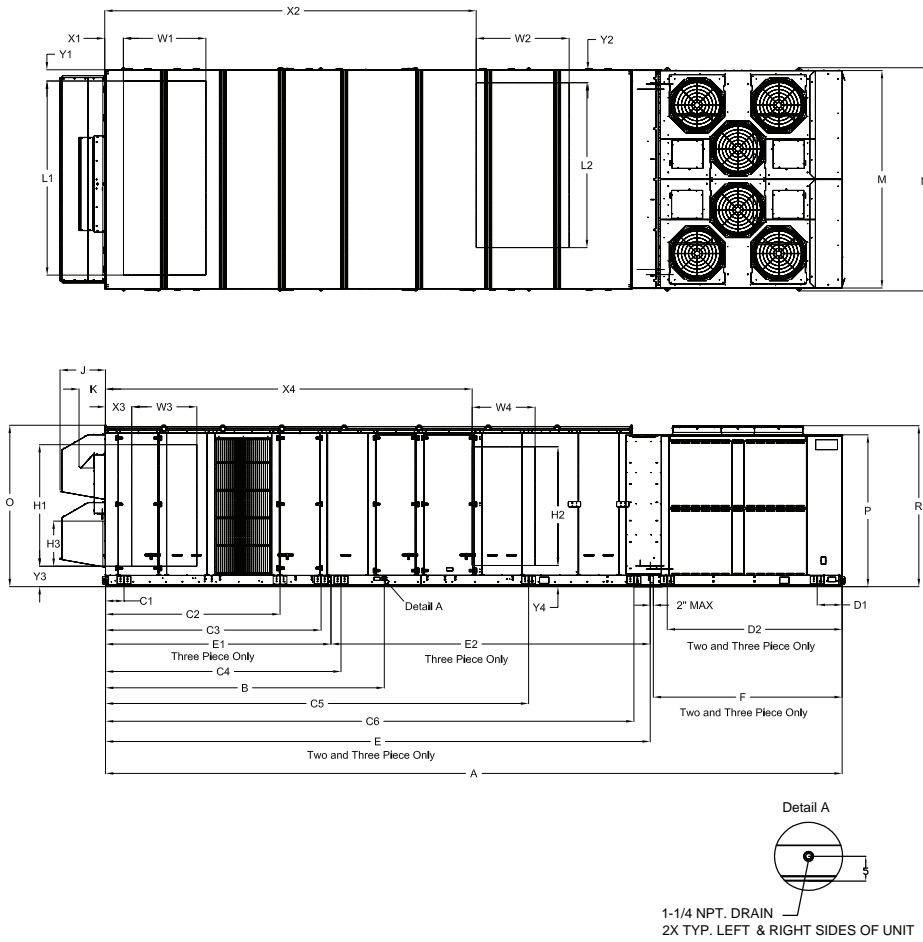


Table 2. Unit dimensions (in.)—ONE-PIECE unit —WITHOUT energy recovery wheel

Tons	Blank Section	Lifting Lug Locations						Unit Width		Unit Height			Return Fan	Exhaust Fan
		Unit Dimensions		Air Handler Side			Condenser Side	M	N	O	P	R	J	K
		A	B	C1	C2	C3	D1							
90	None	437 3/16	159 15/16	66	252 14/16	N/A	27 11/16	139 13/16	143 8/16	103 12/16	97 9/16	103 7/16	29 3/16	17
	4 ft	485 6/16	159 15/16	66	252 14/16	N/A	54 2/16	139 13/16	143 8/16					
	8 ft	533 9/16	159 15/16	66	252 14/16	N/A	54 2/16	139 13/16	143 8/16					
105	None	455 3/16	159 15/16	66	252 14/16	N/A	27 11/16	139 13/16	143 8/16	103 12/16	97 9/16	103 7/16	29 3/16	17
	4 ft	503 6/16	159 15/16	66	252 14/16	N/A	54 2/16	139 13/16	143 8/16					
	8 ft	551 9/16	159 15/16	66	252 14/16	N/A	54 2/16	139 13/16	143 8/16					
120-150 (a)	None	528 15/16	197 1/16	66	269 6/16	N/A	63 2/16	139 13/16	143 8/16	—	—	—	—	—



## Dimensional Data

**Table 2. Unit dimensions (in.)—ONE-PIECE unit —WITHOUT energy recovery wheel (continued)**

Tons	Blank Section	Unit Dimensions		Lifting Lug Locations				Unit Width		Unit Height			Return Fan	Exhaust Fan
				Air Handler Side			Condenser Side	M	N	O	P	R	J	K
		A	B	C1	C2	C3	D1							
120-150 (a)	4 ft	577 2/16	197 1/16	66	269 6/16	N/A	63 2/16	139 13/16	143 8/16	—	—	—	—	—
120-150 (b)	None	540 15/16	197 1/16	66	269 6/16	N/A	63 2/16	139 13/16	143 8/16	—	—	—	—	—

(a) All units except high heat gas models

(b) High heat gas models only

**Table 3. Unit dimensions (in.)—ONE-PIECE unit —WITH energy recovery wheel**

Tons	Blank Section	Unit Dimensions		Lifting Lug Locations				Unit Width		Unit Height		
		A	B	Air Handler Side			Condenser Side	M	N	O	P	R
				C1	C2	C3	D1					
90	None	533 9/16	256 5/16	66	201 1/16	349 4/16	27 11/16	139 13/16	143 8/16	103 12/16	97 9/16	103 7/16
90	4 ft	581 13/16	256 5/16	66	201 1/16	349 4/16	54 2/16	139 13/16	143 8/16	103 12/16	97 9/16	103 7/16
105	None	551 9/16	256 5/16	66	201 1/16	349 4/16	27 11/16	139 13/16	143 8/16	103 12/16	97 9/16	103 7/16
105	4 ft	599 13/16	256 5/16	66	201 1/16	349 4/16	54 2/16	139 13/16	143 8/16	103 12/16	97 9/16	103 7/16
Tons	Blank Section	Return Fan	Exhaust Fan									
		J	K									
90	None	N/A	17									
90	4 ft	N/A	17									
105	None	N/A	17									
105	4 ft	N/A	17									

**Table 4. Unit dimensions (in.)—TWO-PIECE unit —WITHOUT energy recovery wheel**

Tons	Blank Section	Unit Dimensions				Lifting Lug Locations				Lug Locations	
		A	B	E	F	Air Handler Side				Condenser Side	
						C1	C2	C3	C4	D1	D2
90	None	454 4/16	159 15/16	330 14/16	121 6/16	66	252 14/16	N/A	N/A	16	112 7/16
	4 ft	502 7/16	159 15/16	379 1/16	121 6/16	66	252 14/16	368 6/16	N/A	16	112 7/16
	8 ft	550 11/16	159 15/16	427 4/16	121 6/16	66	252 14/16	416 10/16	N/A	16	112 7/16
105	None	472 4/16	159 15/16	330 14/16	139 6/16	66	252 14/16	N/A	N/A	16	130 7/16
	4 ft	520 7/16	159 15/16	379 1/16	139 6/16	66	252 14/16	368 6/16	N/A	16	130 7/16
	8 ft	568 11/16	159 15/16	427 4/16	139 6/16	66	252 14/16	416 10/16	N/A	16	130 7/16
120-150 (a)	None	546	197 1/16	395 10/16	148 6/16	66	269 6/16	384 15/16	N/A	16	139 7/16
120-150 (a)	4 ft	594 4/16	197 1/16	443 13/16	148 6/16	66	269 6/16	433 2/16	N/A	16	139 7/16
120-150 (a)	8 ft	642 7/16	197 1/16	492 1/16	148 6/16	66	269 6/16	481 6/16	N/A	16	139 7/16
120-150 (a)	None	558	197 1/16	407 10/16	148 6/16	66	269 6/16	396 15/16	N/A	16	139 7/16



**Table 4. Unit dimensions (in.)—TWO-PIECE unit —WITHOUT energy recovery wheel (continued)**

Tons	Blank Section	Unit Width		Unit Height			Return Fan	Exhaust Fan
		M	N	O	P	R	J	K
90	None	139 13/16	143 8/16	103 12/16	97 9/16	103 7/16	29 3/16	17
	4 ft	139 13/16	143 8/16	103 12/16	97 9/16	103 7/16	29 3/16	17
	8 ft	139 13/16	143 8/16	103 12/16	97 9/16	103 7/16	29 3/16	17
105	None	139 13/16	143 8/16	103 12/16	97 9/16	103 7/16	29 3/16	17
	4 ft	139 13/16	143 8/16	103 12/16	97 9/16	103 7/16	29 3/16	17
	8 ft	139 13/16	143 8/16	103 12/16	97 9/16	103 7/16	29 3/16	17
120-150 (a)	None	139 13/16	143 8/16	103 12/16	97 9/16	103 7/16	29 3/16	17
120-150 (a)	4 ft	139 13/16	143 8/16	103 12/16	97 9/16	103 7/16	29 3/16	17
120-150 (a)	8 ft	139 13/16	143 8/16	103 12/16	97 9/16	103 7/16	29 3/16	17
120-150 (b)	None	139 13/16	143 8/16	103 12/16	97 9/16	103 7/16	29 3/16	17

(a) High Heat Gas Models Only

(b) High Heat Gas Models Only

**Table 5. Unit dimensions (in.)—TWO-PIECE unit —WITH energy recovery wheel**

Tons	Blank Section	Unit Dimensions				Lifting Lug Locations				Lug Locations	
		A	B	E	F	Air Handler Side				Condenser Side	
						C1	C2	C3	C4	D1	D2
90	None	550 11/16	256 5/16	427 5/16	121 6/16	66	201 1/16	349 4/16	N/A	16	112 7/16
	4 ft	598 14/16	256 5/16	475 8/16	121 6/16	66	201 1/16	349 4/16	464 13/16	16	112 7/16
	8 ft	647 2/16	256 5/16	523 12/16	121 6/16	66	201 1/16	349 4/16	513	16	112 7/16
105	None	568 11/16	256 5/16	427 5/16	139 6/16	66	201 1/16	349 4/16	N/A	16	130 7/16
	4 ft	616 14/16	256 5/16	475 8/16	139 6/16	66	201 1/16	349 4/16	464 13/16	16	130 7/16
	8 ft	665 2/16	256 5/16	523 12/16	139 6/16	66	201 1/16	349 4/16	513	16	130 7/16
120-150(a)	None	642 7/16	293 8/16	492 1/16	148 6/16	66	238 5/16	365 5/16	480 14/16	16	139 7/16
120-150(a)	4 ft	690 10/16	293 8/16	540 4/16	148 6/16	66	238 5/16	365 5/16	529 2/16	16	139 7/16
120-150(a)	8 ft	738 14/16	293 8/16	588 8/16	148 6/16	66	238 5/16	365 5/16	577 5/16	16	139 7/16
120-150(a)	None	654 7/16	293 8/16	504 1/16	148 6/16	66	238 5/16	365 5/16	492 14/16	16	139 7/16

Tons	Blank Section	Unit Width		Unit Height			Return Fan	Exhaust Fan
		M	N	O	P	R	J	K
90	None	139 13/16	143 8/16	103 12/16	97 9/16	103 7/16	N/A	17
	4 ft	139 13/16	143 8/16	103 12/16	97 9/16	103 7/16	N/A	17
	8 ft	139 13/16	143 8/16	103 12/16	97 9/16	103 7/16	N/A	17
105	None	139 13/16	143 8/16	103 12/16	97 9/16	103 7/16	N/A	17
	4 ft	139 13/16	143 8/16	103 12/16	97 9/16	103 7/16	N/A	17
	8 ft	139 13/16	143 8/16	103 12/16	97 9/16	103 7/16	N/A	17
120-150(a)	None	139 13/16	143 8/16	103 12/16	97 9/16	103 7/16	N/A	17
120-150(a)	4 ft	139 13/16	143 8/16	103 12/16	97 9/16	103 7/16	N/A	17
120-150(a)	8 ft	139 13/16	143 8/16	103 12/16	97 9/16	103 7/16	N/A	17
120-150(b)	None	139 13/16	143 8/16	103 12/16	97 9/16	103 7/16	N/A	17

(a) High Heat Gas Models Only

(b) High Heat Gas Models Only



**Dimensional Data**

**Table 6. Downflow/horizontal airflow configuration dimensions (in.) without energy recovery wheel (ERW)**

Tonnage	Blank Section	Gas Heat	DOWNFLOW Opening Dimensions							
			Return Opening-with or without Relief Fan				Return Opening-with Return Fan			
			X1	Y1	W1	L1	X1	Y1	W1	L1
90-105	None	None	14 13/16	8 14/16	48 3/16	121 15/16	14 13/16	42 14/16	48 3/16	53 14/16
	4 ft	None	14 13/16	8 14/16	48 3/16	121 15/16	14 13/16	42 14/16	48 3/16	53 14/16
	8 ft	None	14 13/16	8 14/16	48 3/16	121 15/16	14 13/16	42 14/16	48 3/16	53 14/16
120-150	None	None	14 13/16	8 14/16	48 3/16	121 15/16	14 13/16	42 14/16	48 3/16	53 14/16
	4 ft	None	14 13/16	8 14/16	48 3/16	121 15/16	14 13/16	42 14/16	48 3/16	53 14/16
	8 ft	None	14 13/16	8 14/16	48 3/16	121 15/16	14 13/16	42 14/16	48 3/16	53 14/16
90-105	None	Low/Med/High	14 13/16	8 14/16	48 3/16	121 15/16	14 13/16	42 14/16	48 3/16	53 14/16
	8 ft	Low/Med/High	14 13/16	8 14/16	48 3/16	121 15/16	14 13/16	42 14/16	48 3/16	53 14/16
120-150	None	Low/Med	14 13/16	8 14/16	48 3/16	121 15/16	14 13/16	42 14/16	48 3/16	53 14/16
	8 ft	Low/Med	14 13/16	8 14/16	48 3/16	121 15/16	14 13/16	42 14/16	48 3/16	53 14/16
	None	High	14 13/16	8 14/16	48 3/16	121 15/16	14 13/16	42 14/16	48 3/16	53 14/16
Tonnage	Blank Section	Gas Heat	DOWNFLOW Opening Dimensions				HORIZONTAL Opening Dimensions			
			Supply Opening				Return Side Opening			
			X2	Y2	W2	L2	X3	Y3	W3	H1
90-105	None	None	256 1/16	13	47 14/16	102 8/16	9 5/16	10 10/16	54 12/16	84 15/16
	4 ft	None	304 4/16	13	47 14/16	102 8/16	9 5/16	10 10/16	54 12/16	84 15/16
	8 ft	None	352 8/16	13	47 14/16	102 8/16	9 5/16	10 10/16	54 12/16	84 15/16
120-150	None	None	320 13/16	13	47 14/16	102 8/16	—	—	—	—
	4 ft	None	369	13	47 14/16	102 8/16	—	—	—	—
	8 ft	None	417 3/16	13	47 14/16	102 8/16	9 5/16	10 10/16	54 12/16	84 15/16
90-105	None	Low/Med/High	256 1/16	13	47 14/16	102 8/16	9 5/16	10 10/16	54 12/16	84 15/16
	8 ft	Low/Med/High	352 8/16	13	47 14/16	102 8/16	9 5/16	10 10/16	54 12/16	84 15/16
120-150	None	Low/Med	320 13/16	13	47 14/16	102 8/16	9 5/16	10 10/16	54 12/16	84 15/16
	8 ft	Low/Med	417 3/16	13	47 14/16	102 8/16	9 5/16	10 10/16	54 12/16	84 15/16
	None	High	320 13/16	13	59 14/16	102 8/16	9 5/16	10 10/16	54 12/16	84 15/16
Tonnage	Blank Section	Gas Heat	HORIZONTAL Opening Dimensions							
			Return End Opening				Supply Opening			
			Y1	Y3	H3	L1	X4	Y4	W4	H2
90-105	None	None	6 5/16	8 3/16	35 3/16	127 2/16	254 12/16	10 10/16	54 12/16	84 15/16
	4 ft	None	6 5/16	8 3/16	35 3/16	127 2/16	302 15/16	10 10/16	54 12/16	84 15/16
	8 ft	None	6 5/16	8 3/16	35 3/16	127 2/16	351 2/16	10 10/16	54 12/16	84 15/16
120-150	None	None	—	—	—	—	319 8/16	10 10/16	54 12/16	84 15/16
	4 ft	None	—	—	—	—	367 11/16	10 10/16	54 12/16	84 15/16
	8 ft	None	6 5/16	8 3/16	35 3/16	127 2/16	415 15/16	10 10/16	54 12/16	84 15/16
90-105	None	Low/Med/High	6 5/16	8 3/16	35 3/16	127 2/16	254 12/16	10 10/16	54 12/16	66 11/16
	8 ft	Low/Med/High	6 5/16	8 3/16	35 3/16	127 2/16	351 2/16	10 10/16	54 12/16	84 15/16
120-150	None	Low/Med	6 5/16	8 3/16	35 3/16	127 2/16	319 8/16	10 10/16	54 12/16	66 11/16
	8 ft	Low/Med	6 5/16	8 3/16	35 3/16	127 2/16	415 15/16	10 10/16	54 12/16	84 15/16
	None	High	6 5/16	8 3/16	35 3/16	127 2/16	319 8/16	10 10/16	66 12/16	66 11/16

**Table 7. Downflow/horizontal airflow configuration dimensions (in.) with energy recovery wheel**

Tonnage	Blank Section	Gas Heat	DOWNFLOW Opening Dimensions											
			Return Opening-with or without Relief Fan				Return Opening-with Return Fan				Supply Opening			
			X1	Y1	W1	L1	X1	Y1	W1	L1	X2	Y2	W2	L2
90-105	None	None	82 3/16	8 14/16	49 10/16	121 15/16	N/A	N/A	N/A	N/A	352 8/16	13	47 14/16	102 8/16
	4 ft	None	82 3/16	8 14/16	49 10/16	121 15/16	N/A	N/A	N/A	N/A	400 11/16	13	47 14/16	102 8/16
	8 ft	None	82 3/16	8 14/16	49 10/16	121 15/16	N/A	N/A	N/A	N/A	448 15/16	13	47 14/16	102 8/16
120-150	None	None	82 3/16	8 14/16	49 10/16	121 15/16	N/A	N/A	N/A	N/A	417 4/16	13	47 14/16	102 8/16
	4 ft	None	82 3/16	8 14/16	49 10/16	121 15/16	N/A	N/A	N/A	N/A	465 7/16	13	47 14/16	102 8/16
	8 ft	None	82 3/16	8 14/16	49 10/16	121 15/16	N/A	N/A	N/A	N/A	513 10/16	13	47 14/16	102 8/16
90-105	None	Low/Med/High	82 3/16	8 14/16	49 10/16	121 15/16	N/A	N/A	N/A	N/A	352 8/16	13	47 14/16	102 8/16
	8 ft	Low/Med/High	82 3/16	8 14/16	49 10/16	121 15/16	N/A	N/A	N/A	N/A	448 15/16	13	47 14/16	102 8/16
120-150	None	Low/Med	82 3/16	8 14/16	49 10/16	121 15/16	N/A	N/A	N/A	N/A	417 4/16	13	47 14/16	102 8/16
	8 ft	Low/Med	82 3/16	8 14/16	49 10/16	121 15/16	N/A	N/A	N/A	N/A	513 10/16	13	47 14/16	102 8/16
	None	High	82 3/16	8 14/16	49 10/16	121 15/16	N/A	N/A	N/A	N/A	417 4/16	13	59 14/16	102 8/16
Tonnage	Blank Section	Gas Heat	HORIZONTAL Opening Dimensions											
			Return Side Opening				Supply Opening							
			X3	Y3	W3	H1	X4	Y4	W4	H2				
90-105	None	None	71 8/16	10 10/16	54 12/16	43 6/16	351 3/16	10 10/16	54 12/16	84 15/16				
	4 ft	None	71 8/16	10 10/16	54 12/16	43 6/16	399 6/16	10 10/16	54 12/16	84 15/16				
	8 ft	None	71 8/16	10 10/16	54 12/16	43 6/16	447 10/16	10 10/16	54 12/16	84 15/16				
120-150	None	None	71 8/16	10 10/16	54 12/16	43 6/16	415 15/16	10 10/16	54 12/16	84 15/16				
	4 ft	None	71 8/16	10 10/16	54 12/16	43 6/16	464 2/16	10 10/16	54 12/16	84 15/16				
	8 ft	None	71 8/16	10 10/16	54 12/16	43 6/16	512 6/16	10 10/16	54 12/16	84 15/16				
90-105	None	Low/Med/High	71 8/16	10 10/16	54 12/16	43 6/16	351 3/16	10 10/16	54 12/16	66 11/16				
	8 ft	Low/Med/High	71 8/16	10 10/16	54 12/16	43 6/16	447 10/16	10 10/16	54 12/16	84 15/16				
120-150	None	Low/Med	71 8/16	10 10/16	54 12/16	43 6/16	415 15/16	10 10/16	54 12/16	66 11/16				
	8 ft	Low/Med	71 8/16	10 10/16	54 12/16	43 6/16	512 6/16	10 10/16	54 12/16	84 15/16				
	None	High	71 8/16	10 10/16	54 12/16	43 6/16	415 15/16	10 10/16	66 12/16	66 11/16				

**Notes:**

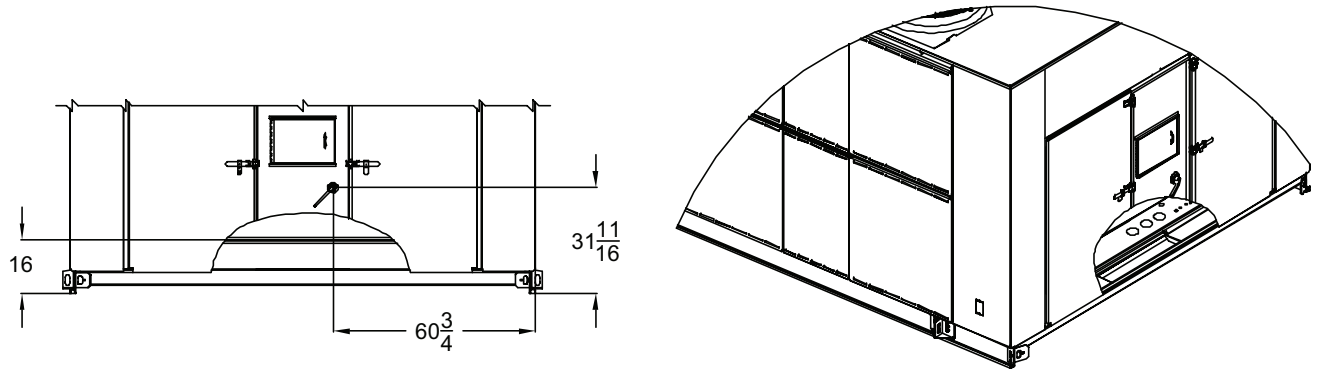
1. On horizontal return with ERW units, the return end opening can be on the front, rear, or both sides of the unit and must be specified.
2. ERW is not allowed w/ end return



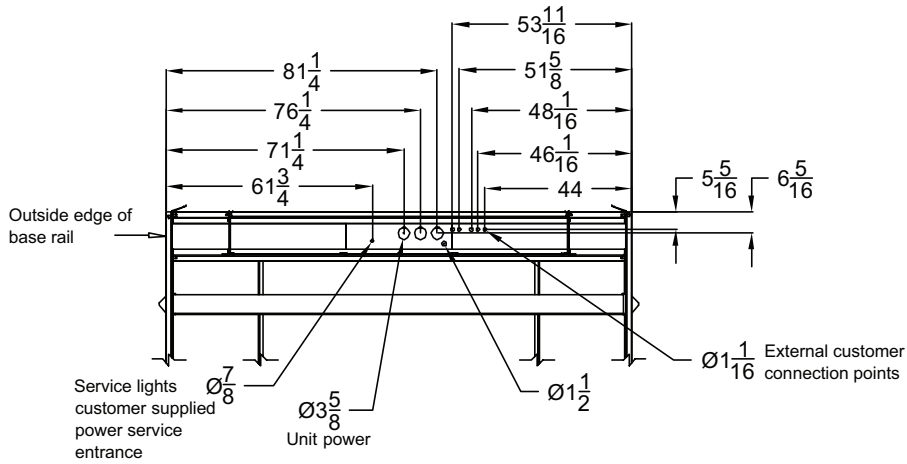
## Dimensional Data

# Electrical Entry Details

Figure 2. Electrical entry details/bottom view

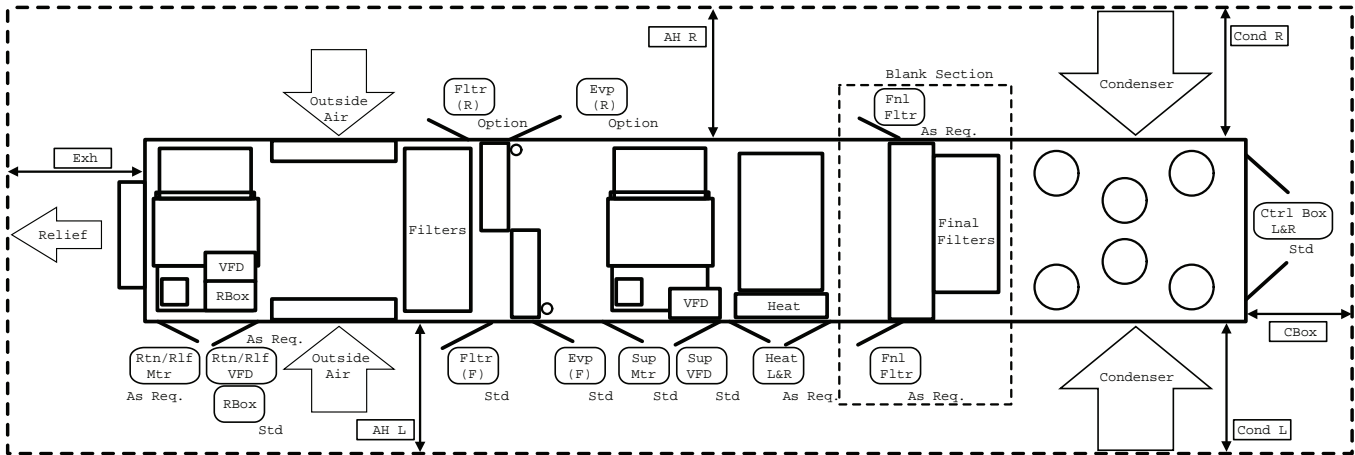


Bottom View



# Minimum Required Clearance

Figure 3. Minimum required clearance



Note: Unit drawing is representative only and may not accurately depict all models.

Table 8. Minimum required clearance

Door Location	Availability	Unit Option Selection (Door Swing Ft. and In.)									
		Standard		VFD		Heat	Two-side Access		Final Filter	Energy Recovery	
		90-105	120-150	Return/Relief	Supply	Electric/Hot Water/Steam	Reheat	90-105			120-150
Relief/Ret Motor	Std	2' 2"	2' 2"	*	*	*	*	*	*	*	
Relief/Ret VFD and Return Control Panel	As Req.	*	*	2' 2"	*	*	*	*	*	*	
ERW Fltr (L & R) (F)	Option	*	*	*	*	*	*	*	*	*	2' 2"
ERW Fltr(a) (L & R) (R)	Option	*	*	*	*	*	*	*	*	*	2' 2"
Filter (Front)	Std	2' 8"	2' 8"	*	*	*	*	*	*	*	
Filter (Rear)	Option	*	*	*	*	*	*	2' 2"	2' 8"	*	
Evap (Front)	Std	2' 2"	2' 2"	*	*	*	*	*	*	*	
Evap (Rear)	Std	2' 8"	*	*	*	*	*	*	*	*	
or Evap (Rear)	Option	*	*	*	*	*	2' 2"	*	2' 2"	*	
Supply Motor	Std	2' 8"	2' 8"	*	*	*	*	*	*	*	
Supply VFD	As Req.	*	*	*	2' 2"	*	*	*	*	*	
Heat (Left & Right)	As Req.	*	*	*	*	2' 2"	*	*	*	*	
Final Filter (Front)	As Req.	*	*	*	*	*	*	*	*	2' 2"	
Final Filter (Rear)	As Req.	*	*	*	*	*	*	*	*	2' 2"	
Control Box (L & R)	Std	3' 2"	3' 2"	*	*	*	*	*	*	*	

Minimum Required Clearance (Ft.)	AH_L	AH_R	Exh	Cond_L	Cond_R	Control Box
	8'	8'	8'	8'	8'	6'

Note: See Unit Dimensions for Energy Recovery Wheel location.



# Weights

**Table 9. Approximate operating weights (lbs.)**

Air-Cooled Units		
Nominal Tons	Unit (Minimum)	Roof Curb (Minimum)
90	14973	907
105	16411	907
120	18447	1040
130	18467	1040
150	19176	1040

**Notes:**

- Weights shown include the following features: No heat, standard evap capacity coils, fixed speed compressors, 0-25% outside air, 2" throwaway filters, low CFM supply fan, minimum supply motor sizes, no return or exhaust fan.
- Weights shown represent approximate minimum operating weights. To calculate weight for a specific unit configuration, utilize TOPSS or contact the local Trane sales representative. Weight outputs have a + 10% accuracy. ACTUAL WEIGHTS ARE STAMPED ON THE UNIT NAMEPLATE.

**Table 10. Component weights**

	90		105		120		130		150	
	Size	Weight	Size	Weight	Size	Weight	Size	Weight	Size	Weight
Refrigeration										
Compressor Assy. - Fixed capacity compressors	-	1126	-	1630	-	1642	-	1666	-	1666
Compressor Assy. - eFlex™ Variable speed	-	1479	-	1503	-	1626	-	1524	-	1786
Air-Cooled Condensing Coil (AI)	-	1173	-	1421	-	1485	-	1485	-	1485
Evap Coil - Std. Cap	-	1034	-	1300	-	1892	-	1892	-	2564
Evap Coil - Hi. Cap.	-	1382	-	1462	-	2564	-	2564	-	
Reheat Coil & Tubing	-	292	-	294	-	367	-	367	-	367
Replaceable Core Filter Driers	-	26	-	25	-	35	-	35	-	35
HGBP	-	46	-	49	-	53	-	53	-	53
Supply Fan Assembly										
Supply Fan & Fan Board Assy. - Low CFM	25"	1159	32"	1361	32"	1361	32"	1361	32"	1361
Supply Fan & Fan Board Assy. - Std. CFM	36"	1490	36"	1490	40"	1653	40"	1653	40"	1653
Belt Guard	-	116	-	116	-	116	-	116	-	116
Supply VFD (50 hp and below)	-	233	-	233	-	233	-	233	-	233
Supply VFD (60-100 hp)	-	284	-	284	-	284	-	284	-	284
Supply Fan Motor - 15 hp	-	181	-	181	-	181	-	181	-	181
Supply Fan Motor - 20 hp	-	206	-	206	-	206	-	206	-	206
Supply Fan Motor - 25 hp	-	358	-	358	-	358	-	358	-	358
Supply Fan Motor - 30 hp	-	413	-	413	-	413	-	413	-	413
Supply Fan Motor - 40 hp	-	495	-	495	-	495	-	495	-	495
Supply Fan Motor - 50 hp	-	604	-	604	-	604	-	604	-	604
Supply Fan Motor - 60 hp	-	776	-	776	-	776	-	776	-	776
Supply Fan Motor - 75 hp	-	879	-	879	-	879	-	879	-	879
Supply Fan Motor - 100 hp	-	1102	-	1102	-	1102	-	1102	-	1102
Return/Relief Fan Assembly										
Return Fan & Dampers - Low CFM	36"	2294	36"	2294	36"	2294	36"	2294	36"	2294
Return Fan & Dampers - Std. CFM	40"	2343	40"	2343	44"	2445	44"	2445	44"	2445
Exhaust Fan & Dampers - Low CFM	25"	889	28"	979	28"	979	28"	979	28"	979
Exhaust Fan & Dampers - Std. CFM	28"	979	32"	1429	32"	1429	32"	1429	32"	1429
Belt Guard	-	119	-	119	-	119	-	119	-	119

**Table 10. Component weights (continued)**

	90		105		120		130		150	
	Size	Weight	Size	Weight	Size	Weight	Size	Weight	Size	Weight
Exhaust / Return VFD (50 hp and below)	-	244	-	244	-	244	-	244	-	244
Exhaust / Return VFD (60-100 hp)	-	295	-	295	-	295	-	295	-	295
Exh / Rtn Fan Motor - 7.5 hp	-	160	-	160	-	160	-	160	-	160
Exh / Rtn Fan Motor - 10 hp	-	181	-	181	-	181	-	181	-	181
Exh / Rtn Fan Motor - 15 hp	-	206	-	206	-	206	-	206	-	206
Exh / Rtn Fan Motor - 20 hp	-	206	-	206	-	206	-	206	-	206
Exh / Rtn Fan Motor - 25 hp	-	358	-	358	-	358	-	358	-	358
Exh / Rtn Fan Motor - 30 hp	-	413	-	413	-	413	-	413	-	413
Exh / Rtn Fan Motor - 40 hp	-	495	-	495	-	495	-	495	-	495
Exh / Rtn Fan Motor - 50 hp	-	604	-	604	-	604	-	604	-	604
Exh Fan Motor - 60 hp	-	776	-	776	-	776	-	776	-	776
Heat										
Gas Heat Low	0.85M	690	0.85M	690	1.1M	840	1.1M	840	1.1M	840
Gas Heat Med	1.1M	840	1.1M	840	1.8M	1150	1.8M	1150	1.8M	1150
Gas Heat High	1.8M	1150	1.8M	1150	2.5M	1398 <sup>(a)</sup>	2.5M	1398	2.5M	1398
Electric Heat	-	485	-	485	-	485	-	485	-	485
Steam Heat Low	-	753	-	753	-	802	-	802	-	802
Steam Heat High	-	821	-	821	-	886	-	886	-	886
Hot Water Heat Low	-	773	-	773	-	841	-	841	-	841
Hot Water Heat High	-	818	-	818	-	897	-	897	-	897
Filters										
Filter Rack - Throwaway Filters	-	181	-	181	-	191	-	191	-	191
Filter Rack - Bag Filters	-	395	-	395	-	395	-	395	-	395
Filter Rack - Cartridge Filters	-	662	-	662	-	662	-	662	-	662
Final Filters - Bag Filters	-	392	-	392	-	392	-	392	-	392
Final Filters - Cartridge Filters w/ 2" pre-filter	-	607	-	607	-	607	-	607	-	607
Final Filters - Cartridge Filters w/ 4" pre-filter	-	638	-	638	-	638	-	638	-	638
Final Filters - High Temp. Cartridge	-	669	-	669	-	669	-	669	-	669
Final Filters - HEPA	-	1777	-	1777	-	1777	-	1777	-	1777
Final Filters - HEPA High Temp.	-	1839	-	1839	-	1839	-	1839	-	1839
Outside Air										
0-25% Damper	-	637	-	637	-	699	-	699	-	699
Econ	-	760	-	760	-	865	-	865	-	865
Econ w/ Air Measure	-	724	-	724	-	807	-	807	-	807
ERW, Low CFM w/ Econ <sup>(b)</sup>	-	3307	-	3307	-	3518	-	3681	-	3681
ERW, High CFM w/ Econ <sup>(b)</sup>	-	3545	-	3514	-	3756	-	3756	-	3756
ERW, Low CFM w/ Econ & Air Measure <sup>(b)</sup>	-	3487	-	3487	-	3727	-	3890	-	3890
ERW, High CFM w/ Econ & Air Measure <sup>(b)</sup>	-	3725	-	3694	-	3965	-	3965	-	3965
Cabinet										
Cabinet	-	8097	-	8315	-	9473	-	9473	-	9473
Cabinet - 4' Blank Section	-	935	-	935	-	901	-	901	-	901
Cabinet - 8' Blank Section	-	1709	-	1709	-	1682	-	1682	-	1682
Electrical Panels										
Control Box - Main	-	519	-	519	-	519	-	519	-	519
Convenience Outlet	-	36	-	36	-	36	-	36	-	36
Return Box	-	80	-	80	-	80	-	80	-	80
Junction Box	-	60	-	60	-	60	-	60	-	60
2-Piece Unit Adder										
2-Piece Adder	-	406	-	406	-	406	-	406	-	406

<sup>(a)</sup> 2.5M includes weight associated with 12" of cabinet length

<sup>(b)</sup> Energy Recovery includes weight associated w/ 96" of cabinet length.



## Weights

**Table 11. Roof curb weights**

Tonnage	Energy Recovery Wheel	Blank Section	One-Piece Unit	Two-Piece Unit
90-105	No	None	907	1055
90-105	No	4 ft	988	1136
90-105	No	8 ft	1069	1217
90-105	Yes	None	1093	1240
90-105	Yes	4 ft	1174	1321
90-105	Yes	8 ft	N/A	1401
120-150 (All Units Except High Heat Gas models)	No	None	1040	1194
120-150 (All Units Except High Heat Gas models)	No	4 ft	1122	1275
120-150 (All Units Except High Heat Gas models)	No	8 ft	N/A	1357
120-150 (High Heat Gas Models Only)	No	None	1055	1209
120-150 (All Units Except High Heat Gas models)	Yes	None	N/A	1378
120-150 (All Units Except High Heat Gas models)	Yes	4 ft	N/A	1459
120-150 (All Units Except High Heat Gas models)	Yes	8 ft	N/A	1540
120-150 (High Heat Gas Models Only)	Yes	None	N/A	1393





# Installation

## Roof Curb and Ductwork

The roof curbs consist of two main components: a pedestal to support the unit condenser section and a “full perimeter” enclosure to support the unit’s air handler section.

Before installing any roof curb, verify the following:

- It is the correct curb for the unit.
- It includes the necessary gaskets and hardware.
- The purposed installation location provides the required clearance for proper operation.
- The curb is level and square — the top surface of the curb must be true to assure an adequate curb-to-unit seal.

Step-by-step curb assembly and installation instructions ship with each Trane accessory roof curb kit. Follow the instructions carefully to assure proper fit-up when the unit is set into place.

**Note:** To assure proper condensate flow during operation, the unit (and curb) must be as level as possible. The maximum slope allowable for rooftop unit applications excluding Steam Heat Units, is 4" end-to-end and 2" side-to-side. Units with steam coils must be set level!

If the unit is elevated, a field constructed catwalk around the unit is strongly recommended to provide easy access for unit maintenance and service. Recommendations for installing the Supply Air and Return Air ductwork joining the roof curb are included in the curb instruction booklet. Curb ductwork must be fabricated and installed by the installing contractor before the unit is set into place.

**Note:** For sound consideration, cut only the holes in the roof deck for the ductwork penetrations. Do not cut out the entire roof deck within the curb perimeter.

### Pitch Pocket Location

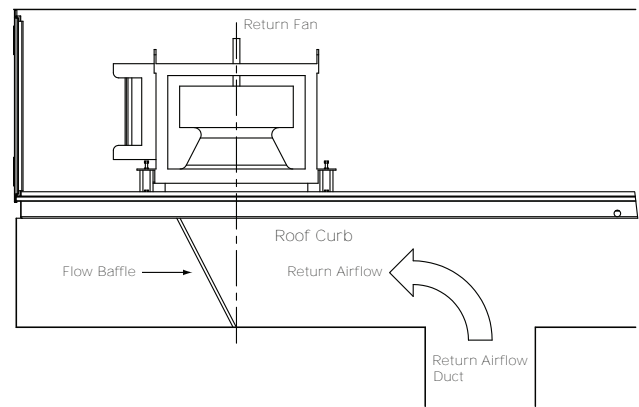
The location of the main supply power entry is located at the bottom right-hand corner of the control panel. Illustrates the location for the electrical entrance through the base in order to enter the control panel. If the power supply conduit penetrates the building roof beneath this opening, it is recommended that a pitch pocket be installed before the unit is placed onto the roof curb.

The center line dimensions shown in the illustration below indicates the center line of the electrical access hole in the

unit base when it is positioned on the curb,  $\pm 3/8$  inch. The actual diameter of the hole in the roof should be at least 1/2 inch larger than the diameter of the conduit penetrating the roof. This will allow for the clearance variable between the roof curb rail and the unit base rail illustrated in Figure 5, p. 26.

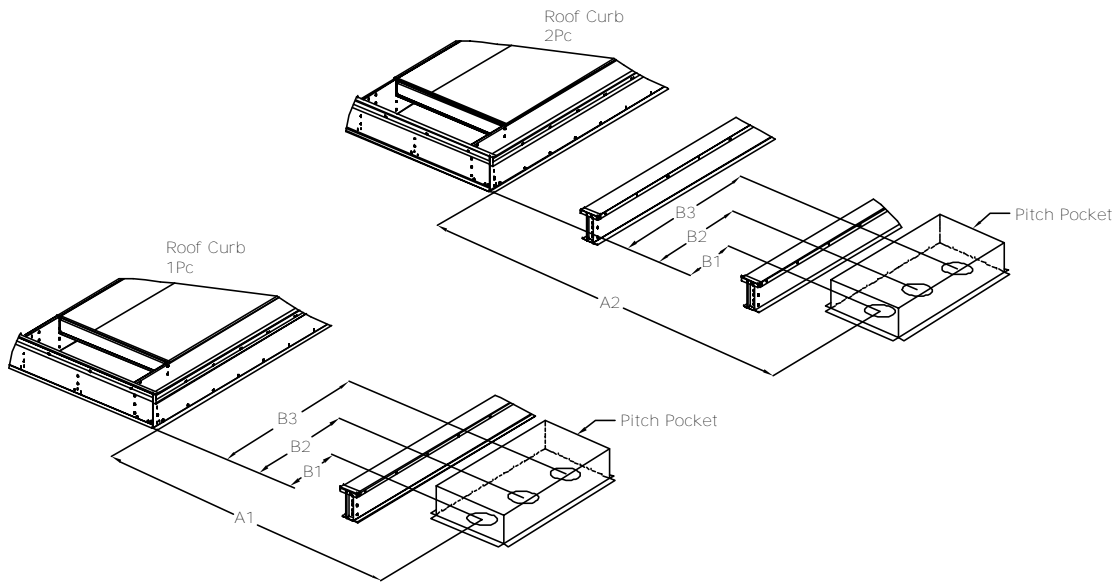
The pitch pocket dimensions listed are recommended to enhance the application of roofing pitch after the unit is set into place. The pitch pocket may need to be shifted as illustrated to prevent interference with the curb pedestal.

**Figure 4. Solid flow baffle wall installation for non-Trane roof curbs**



If a Trane Curb Accessory Kit is not used:

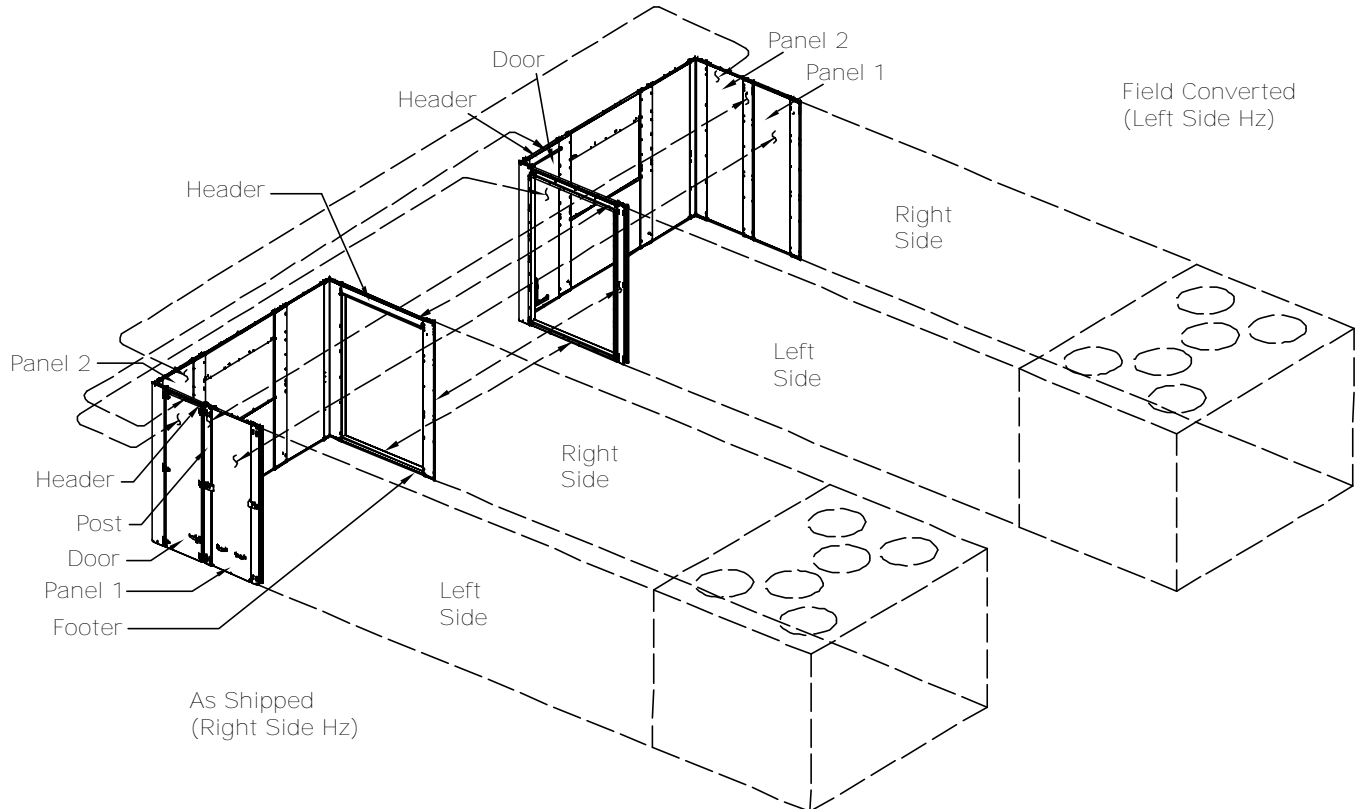
- The ductwork can be attached directly to the unit bottom, around the unit supply and return air openings. Be sure to use flexible duct connections at the unit.
- For “built-up” curbs supplied by others, gaskets must be installed around the curb and the supply and return air opening perimeters.
- If a “built-up” curb is provided by others, it should NOT be made of wood.
- If a “built-up” curb is provided by others, keep in mind that these commercial rooftop units do not have base pans in the condenser section.
- If this is a REPLACEMENT UNIT keep in mind that the CURRENT DESIGN commercial rooftop units do not have base pans in the condenser section.

**Figure 5. Pitch pocket location**

**Table 12. Pitch pocket dimensions (in.)**

Tonrages	One-Piece	Two-Piece	One or Two -Piece		
	A1	A2	B1	B2	B3
90	113.8	129.9±1	68.875	73.875	78.875
105	131.8	147.9±1	68.875	73.875	78.875
120,130,150	140.8	156.9±1	68.875	73.875	78.875

## Field Converting Horizontal Ductwork (Supply or Return) from Right to the Left Side

Figure 6. Ductwork conversion

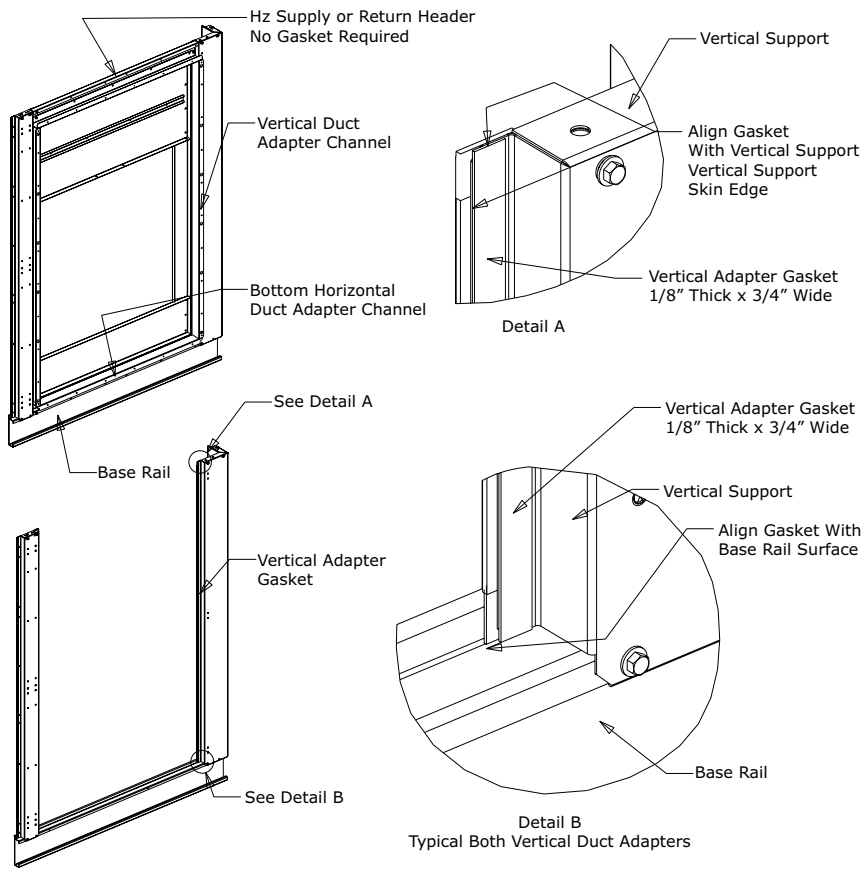


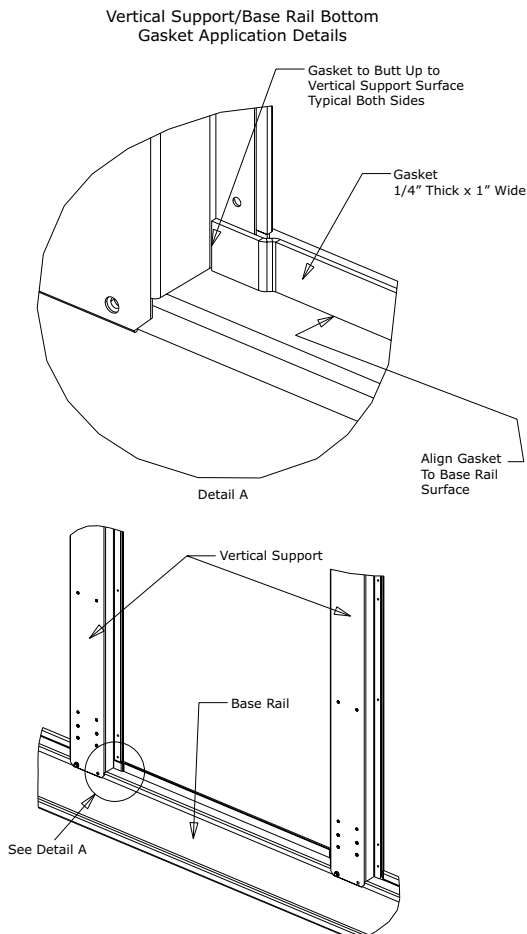
To field convert horizontal ductwork from right side to the left, follow this procedure:

1. Remove Panel 2 from end of unit
2. Remove the Door and Door header from the left side.
3. Assemble Door header and Door removed from the left side in the empty location on the end wall.
4. Remove Panel 1 and Post from the left side. Remove gaskets from the base rail flange at the bottom.
5. Remove the top duct adapter, side duct adapters, header, and footer in this order from the right side. Remove gaskets from post side flanges and the base rail flange at the bottom.
6. Assemble gaskets, header, footer, side duct adapters, and top duct adapter in this order to the left side. See [Figure 6, p. 27](#) for gasket application details.
7. Finally assemble Post, gaskets, Panel 1, and Panel 2 in this order to the right side to complete the field conversion. See [Figure 7, p. 28](#) and [Figure 8, p. 29](#) for gasket application details.

Figure 7. Ductwork conversion

Hz Return & Supply Gasketing Application Details



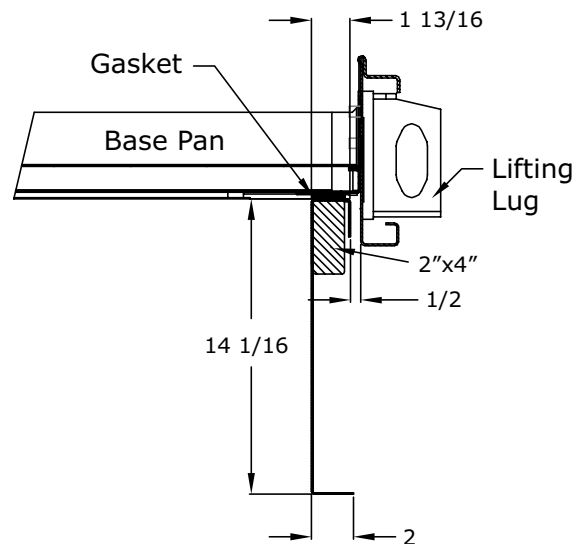
**Figure 8. Ductwork conversion**


1. To configure the unit Center-of-Gravity, utilize Trane Select Assist or contact the local Trane sales office.
2. Attach adequate strength lifting slings to all lifting lugs. The figures beginning with **Figure 10**, p. 30 show the minimum distance between the lifting hook and the top of the unit and illustrate the installation of spreader bars to protect the unit and to facilitate a uniform lift. lists typical approximate minimal unit operating weights. To determine additional component weight, see .
3. Test lift the unit to ensure it is properly rigged and balanced, make any necessary rigging adjustments.
4. Lift the unit and position it over the curb and pedestal. These units have a continuous base rail around the air handler section which matches the curb.

**Important:** For replacements, remove old gasket from the roof curb and place new gasket material on curb. See “;” to determine gasket material length using roof curb dimensions.

5. Align the base rail of the unit air handler section with the curb rail while lowering the unit onto the curb. Make sure that the gasket on the curb is not damaged while positioning the unit. (The pedestal simply supports the unit condenser section)

A cross section of the juncture between the unit and the roof curb is shown below.

**Figure 9. Curb cross section**


## Unit Rigging and Placement

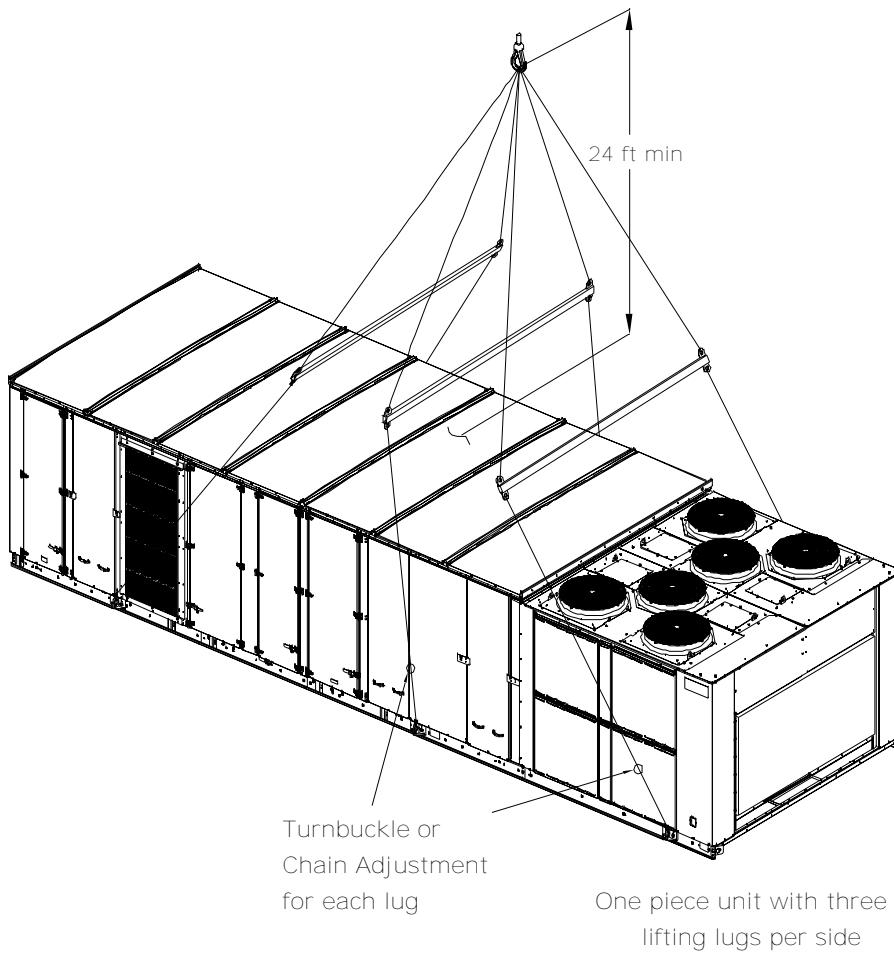
### **⚠ WARNING**

#### **Heavy Object!**

Failure to follow instructions below could result in unit dropping which could result in death or serious injury, and equipment or property-only damage.

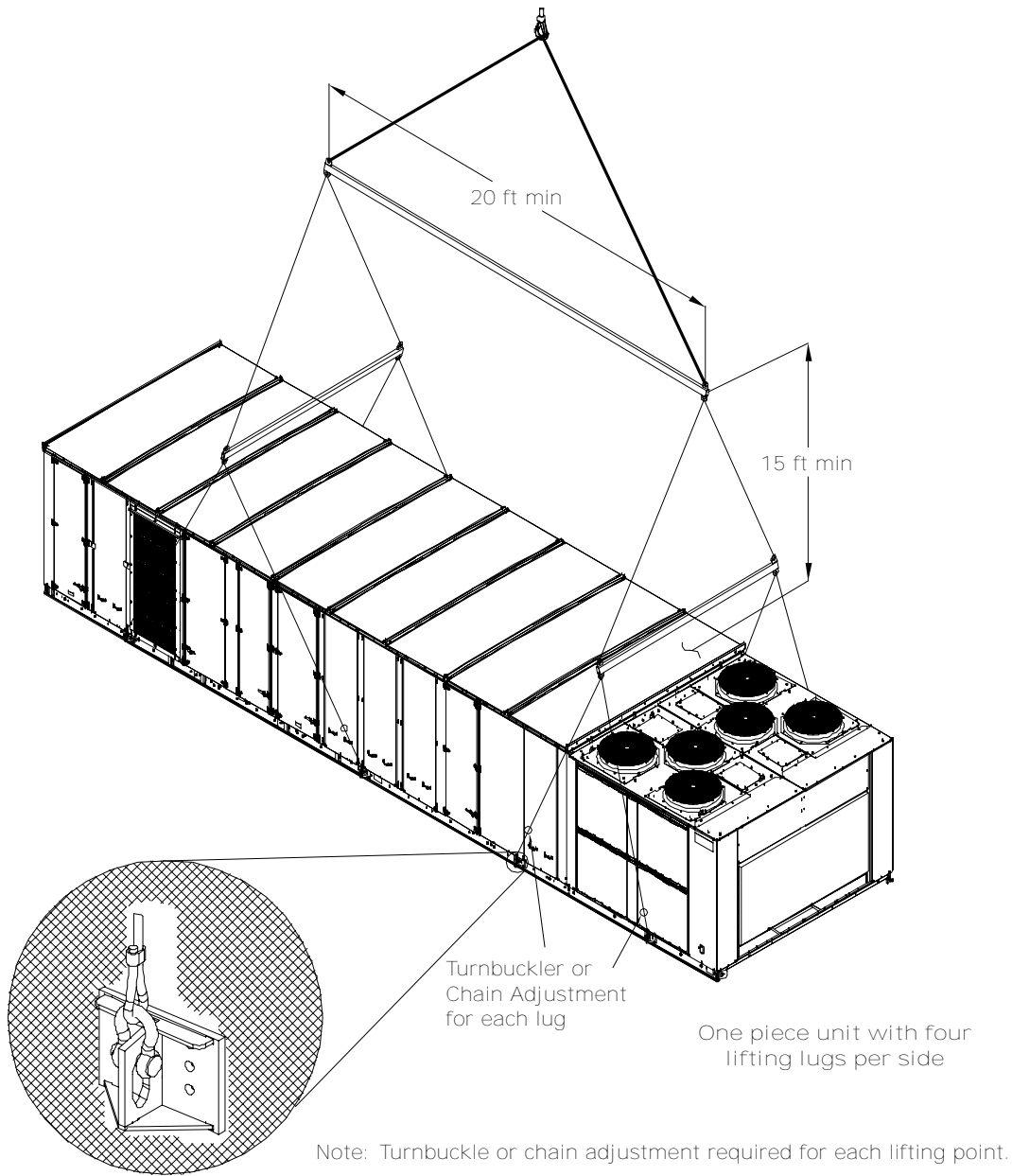
Ensure that all the lifting equipment used is properly rated for the weight of the unit being lifted. Each of the cables (chains or slings), hooks, and shackles used to lift the unit must be capable of supporting the entire weight of the unit. Lifting cables (chains or slings) may not be of the same length. Adjust as necessary for even unit lift.

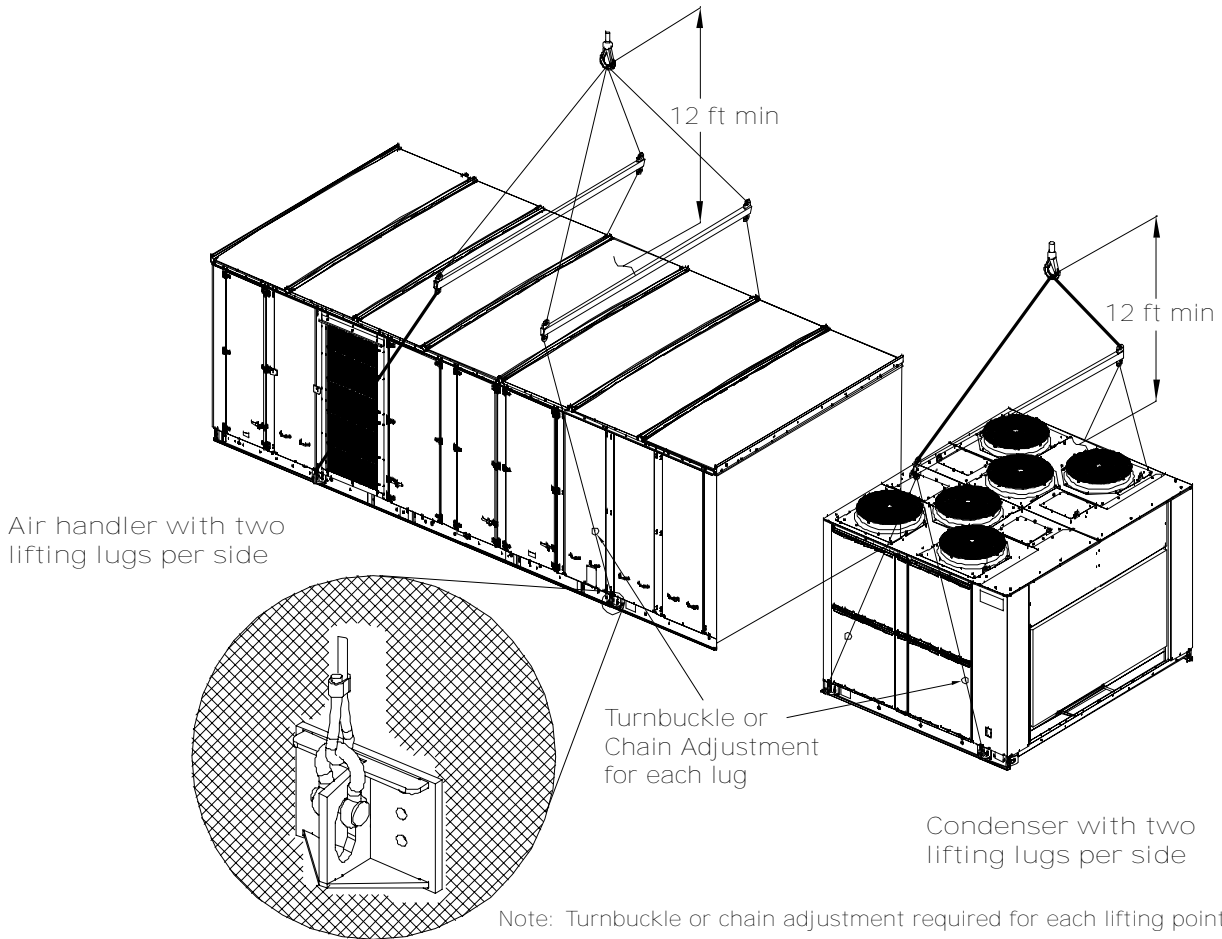
**Figure 10. Typical unit rigging—one-piece unit with three lifting lugs per side**



Note: Turnbuckle or chain adjustment required for each lifting point.

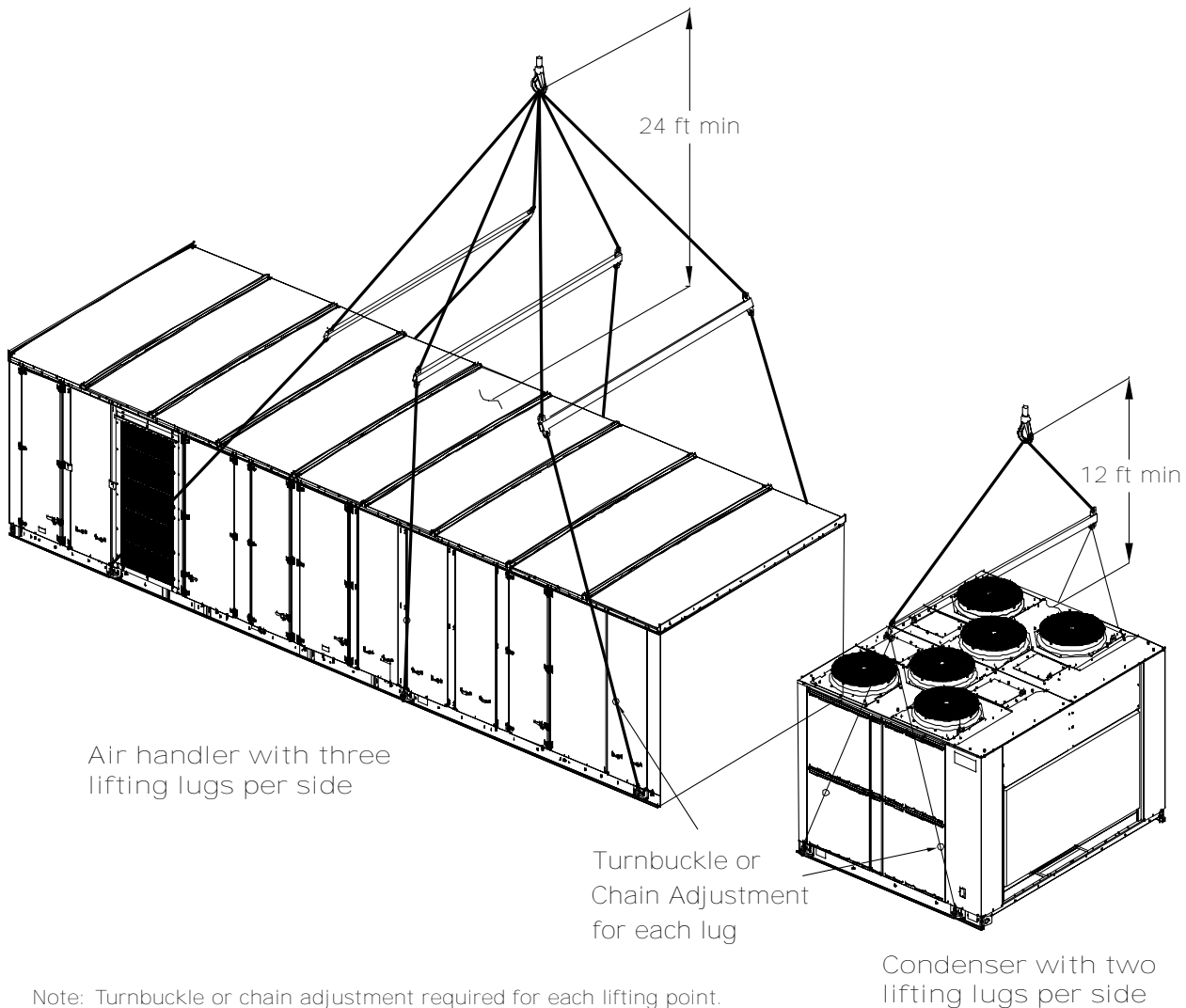
Figure 11. Typical unit rigging—one piece unit with four lifting lugs per side



**Figure 12. Typical unit rigging—two-piece unit with two lifting lugs per side**



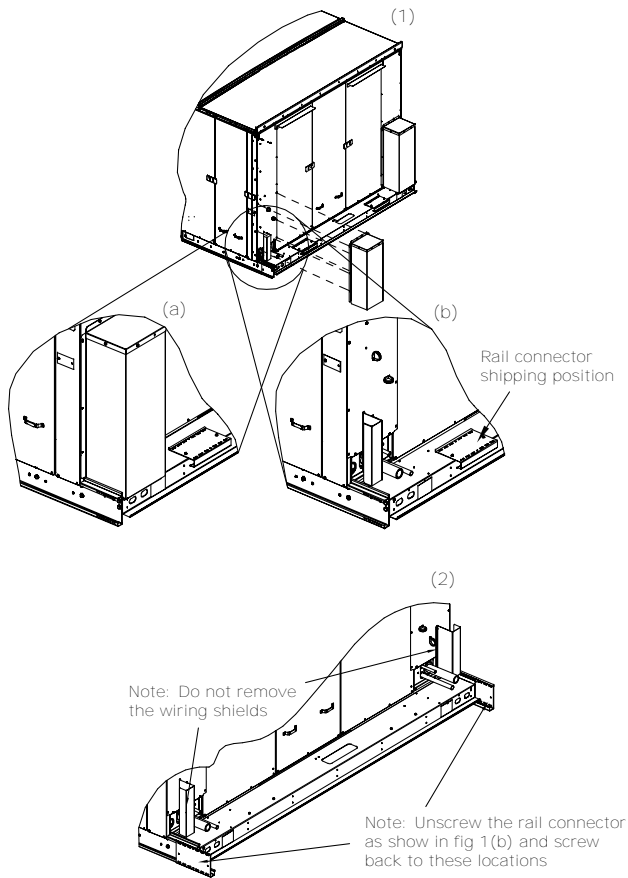
**Figure 13. Typical unit rigging—two-piece unit with three lifting lugs per air handler side**



### Air-Cooled Condensers—Two-Piece Unit Fit Up

1. Rig the low side unit (Air handler) and the high side unit (Condenser) separately.
2. First, rig and set the low side unit on the roof curb (aligned with return end).
3. Take off and discard the protection boxes. (Do not remove wire shields).
4. Remove the rail connector splice brackets and install the brackets on the low side unit base rails.
5. Take off the side panels (these are labeled) and the top cover of the high side unit and set aside to be assembled later.
6. Rig and set the high side unit on roof curb pedestal, using the rail splice bracket as an alignment aid to connect the Low and high side units. The Low and high side unit rails should be butted together with a maximum 2" separation.
7. Remove the left upper and lower louvered panels and the corner panels on each side to aid in tubing and wiring connections.

**Figure 14. (1) Protection box removal/(2) rail connector installation position**



**Figure 15. (3) Side and top filler panel removal/(4) high side installation preparation**

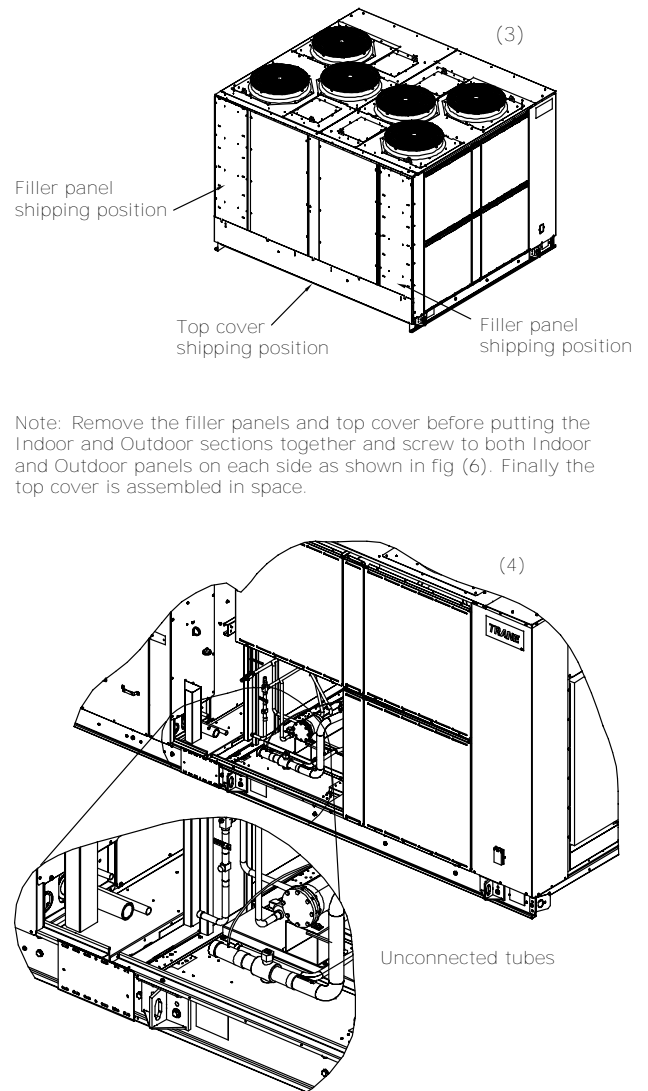


Figure 16. (5) Connected tubes/(6) install panels

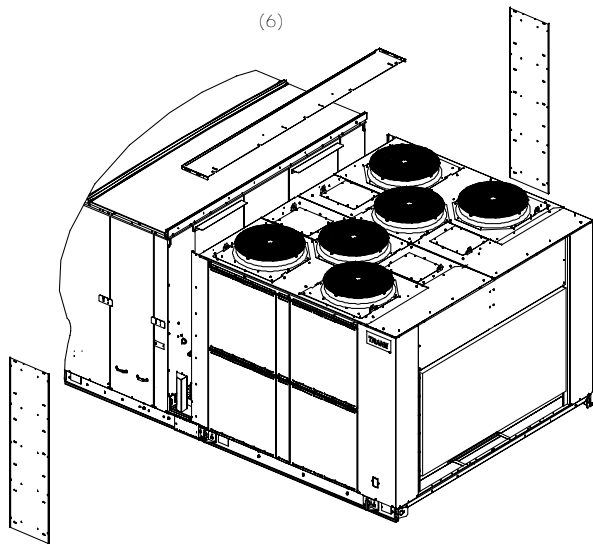
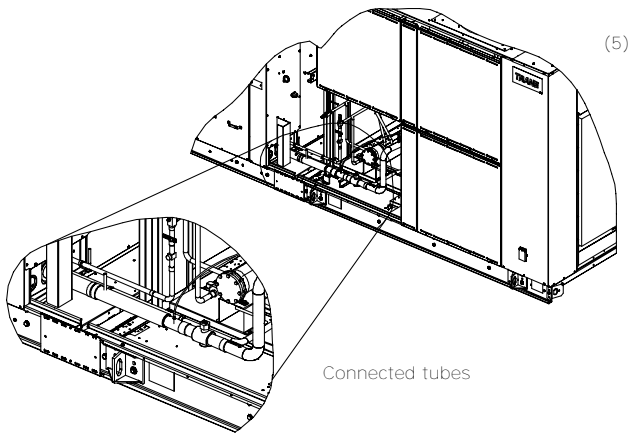
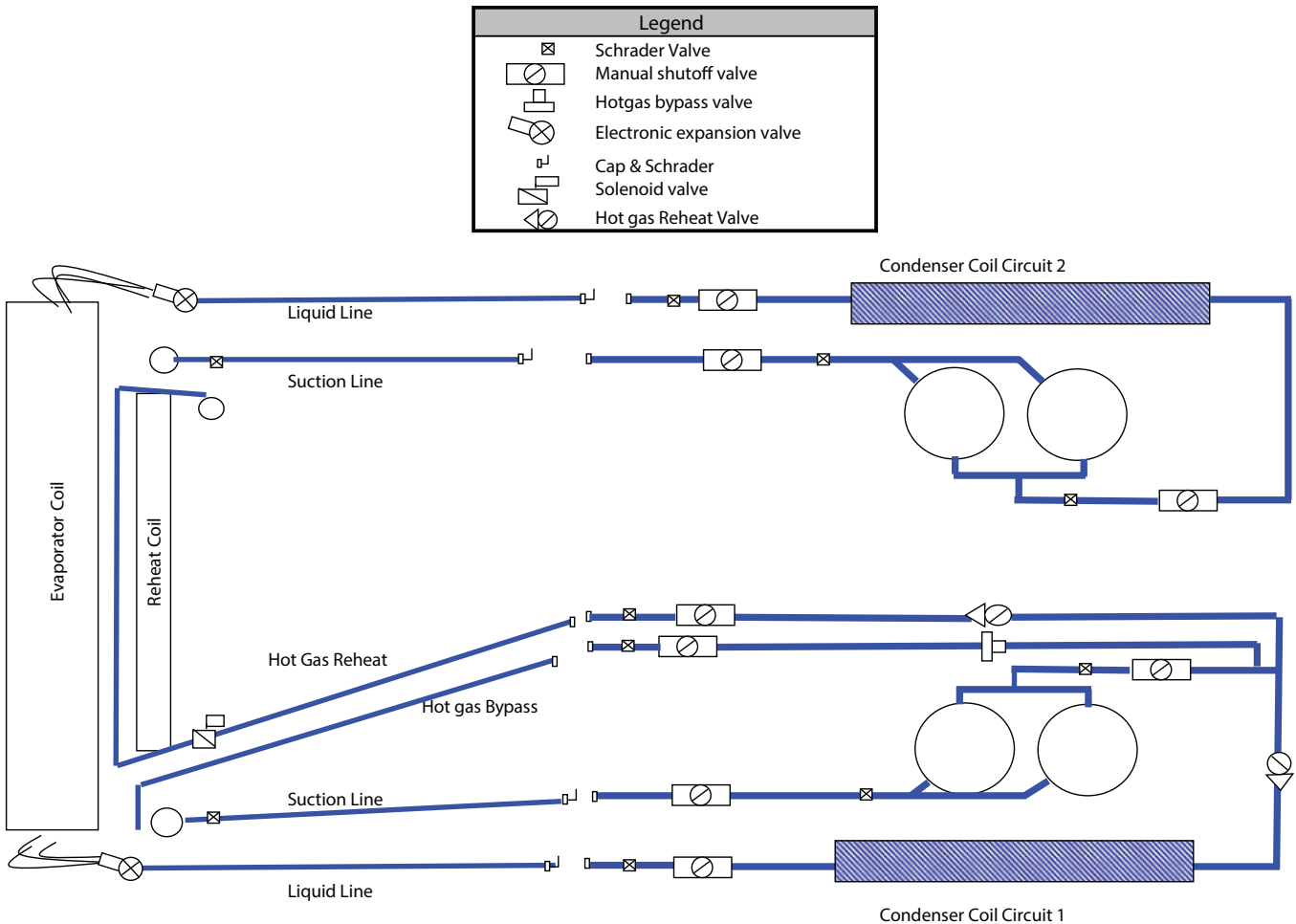


Figure 17. Refrigeration diagram



## Tubing and Wiring Connections

### Air-Cooled Tubing Connection

One piece Air Cooled units are shipped with refrigerant throughout the entire tubing assemblies.

Two piece Air-Cooled low side and condenser sections are shipped with a Nitrogen holding charge. All service valves are shipped in an open position. Additional interconnecting tubes (approx. 15-20" in length) will be supplied with the unit.

**Note:** Field charging of two piece air-cooled units is **REQUIRED**.

To prepare the two piece sections for joining install pressure gauges to the appropriate access valve(s) to verify nitrogen charge is present.

1. Relieve the pressure before attempting to unsweat the "seal" caps.
2. Remove the brackets which support the suction tubes (retain for possible use later for unit reassembly) after the tubing connections are complete.
3. Place wet rags on the flow/ ball valve on the high side when suction tubes are being brazed.

**Note:** Additional care should be taken when brazing near the wire bundle.

4. Sweat the copper caps off both the high and low side of the suction and liquid lines of both circuits. If present also sweat off the copper caps from hot gas bypass or hot gas reheat lines.
5. Clean the joints of weld puddles to avoid insertion problems.
6. Cut the appropriate interconnecting tube to a length approximately 0.75"- 1" more than the distance between the two tubes.
7. Insert the appropriate tube to the complete depth of the bell on one side of the joint and align the other side (prying the high side may be needed). Make sure the insertion depth is met.
8. Complete the connections by brazing the tubes in place.

**Note:** Refrigeration ball valves are intended for general service and are not a positive shutoff device.

9. Once all connections have been brazed, evacuate the entire system. The recommended method for evacuation and dehydration is to evacuate the system

to 500 microns or less. To establish that the unit is leak-free, use a standing vacuum test. The maximum allowable rise over a 15 minute period is 200 microns. If the rise exceeds this, there is either still moisture in the system or a leak is present.

10. Charge the system per the unit nameplate field charge. Do not add refrigerant in the suction line at this time to prevent excessive refrigerant in the low side prior to compressor start-up.
11. At the liquid line angle valve add as much R-410A LIQUID as possible. Depending on conditions, it could not be possible to add more than 60% of the field charge. This will be adequate for compressor start-up. More charge will be added after compressors are started. Use an accurate scale to measure and record the preliminary amount of R-410A added to each circuit.
12. With all the circuit compressors operating, SLOWLY meter R410-A into the suction line from the LIQUID charging connection.

### Electric Heat Wiring Connection

#### **⚠ WARNING**

#### **Proper Field Wiring and Grounding Required!**

**Failure to follow code could result in death or serious injury.**

**All field wiring MUST be performed by qualified personnel. Improperly installed and grounded field wiring poses FIRE and ELECTROCUTION hazards. To avoid these hazards, you MUST follow requirements for field wiring installation and grounding as described in NEC and your local/state/national electrical codes.**

**Important:** For units with electric heat, complete tubing connections **AFTER** completing wiring connections. See "Tubing Connections" section.

1. Cut and remove wire ties which hold the electric control wires together, remove the shield bracket. Leave the armaflex on the hole with the control wires.
2. Cut the lowest wire tie which holds the electric heat power wires to the vertical post on the high side.
3. Route the power wires one by one in to the hole on the low side end panel and connect them to the terminal

block inside the electric Junction Box or inside the extended casing section.

**Note:** For 8' extended casing units, remove the panel (this panel weighs approximately 60 pounds) next to the corner post in the low side to locate the terminal block.

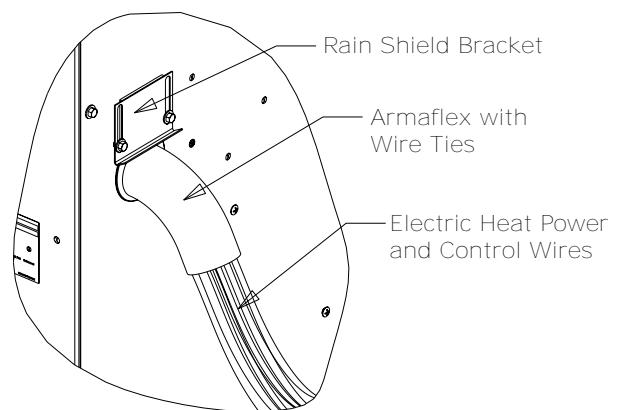
4. Bundle the electric heat power and control wires with armaflex wrap on the low side end of the unit. Screw the shield bracket to compress the wire bundle and create a good seal, see [Figure 19, p. 38](#).
5. Route the electric heat control wires to the Junction box located on the high side, see [Figure 19, p. 38](#).

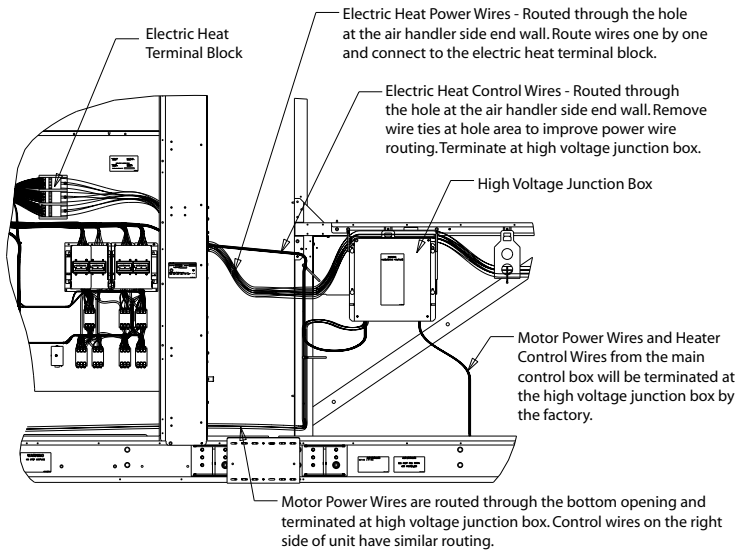
### Power and Control Wiring Connections

**Note:** Complete Power and Control Wiring Connections after the tubing connections are complete.

1. Discard the clamps and the wire shield which hold the power and control wires.
2. Make the power and the control wire connections and route the wires such that they route straight from the hole at the bottom of the air handler, turn at right angles and straight up through the bottom of the high voltage junction box on the condenser side, see [Figure 19, p. 38](#).
3. Assemble the louvered panels and the corner panels in the condenser side back in place.
4. Screw the side panels to both the air handler and condenser side panels to act as filler panels.
5. Finally, assemble the top cover back in place.

**Figure 18. Wire routing at low side end wall**

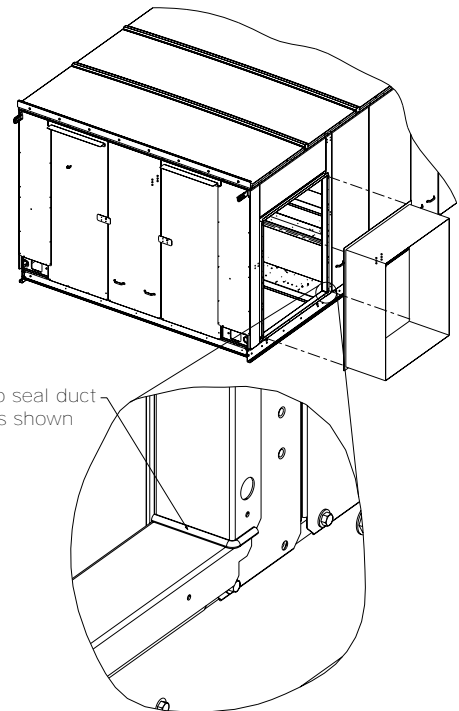


**Figure 19. Wire routing and connections**


## General Installation Requirements

The checklist below is a summary of the steps required to successfully install a Commercial rooftop unit. This checklist is intended to acquaint the installing personnel with what is required in the installation process. It does not replace the detailed instructions called out in the applicable sections of this manual.

- Complete “Unit Inspection,” p. 12 checklist.
- Verify that the installation location of the unit will provide the required clearance for proper operation.
- Assemble and install the roof curb. Refer to the current edition of the roof curb installer’s guide.
- Fabricate and install ductwork; secure ductwork to curb. Seal the corners of duct adapters as shown below. Ducting attached to the unit should be self supporting. Do not use the unit to support the weight of the ducting.
- Install pitch pocket for power supply through building roof. (If applicable).

**Figure 20. Sealed ductwork**


## Rigging the Unit

- Set the unit onto the curb; check for levelness.
- Ensure unit-to-curb seal is tight and without buckles or cracks.
- Install and connect condensate drain lines to each evaporator drain connection.
- Remove the shipping hardware from each compressor assembly.

- Remove the shipping hold-down bolts and shipping channels from the supply and relief fans with spring isolators.
- Check all supply and relief fan spring isolators for proper adjustment.
- Verify all discharge line service valves (one per circuit) are back seated.

### Main Electrical Power

- Verify that the power supply complies with the unit nameplate specifications. Refer to Main Unit Power Wiring in the Installation chapter.
- Inspect all control panel components; tighten any loose connections.
- Connect properly sized and protected power supply wiring to a field-supplied/installed disconnect and unit
- Properly ground the unit.
- All field-installed wiring must comply with NEC and applicable local codes.

### Field Installed Control Wiring

- Complete the field wiring connections as shown on the unit schematics.

**Note:** All field-installed wiring must comply with NEC and applicable local codes.

### Electric Heat Units

- Verify that the power supply complies with the electric heater specifications on the unit and heater nameplate.
- Inspect the heater junction box and control panel; tighten any loose connections.
- Check electric heat circuits for continuity.

### Gas Heat

- Gas supply line properly sized and connected to the unit gas train.
- All gas piping joints properly sealed.
- Drip leg installed in the gas piping near the unit.
- Gas piping leak checked with a soap solution. If piping connections to the unit are complete, do not pressurize piping in excess of 0.50 psig or 14 inches w.c. to prevent component failure.
- Main supply gas pressure adequate.
- Flue Tubes clear of any obstructions.
- Factory-supplied flue assembly installed on the unit.
- Connect the 3/4" CPVC furnace drain stubout to a proper condensate drain. Provide heat tape or insulation for condensate drain as needed.

### Hot Water Heat

- Route properly sized water piping through the base of the unit into the heating section.

- Install the factory-supplied, 3-way modulating valve.
- Refer to the schematic to complete the valve actuator wiring.

### Steam Heat

- Route properly sized steam piping through the base of the unit into the heating section.
- Install the factory-supplied, 2-way modulating valve
- Complete the valve actuator wiring.
- Install 1/2", 15-degree swing-check vacuum breaker(s) at the top of each coil section. Vent breaker(s) to the atmosphere or merge with return main at discharge side of steam trap.
- Position the steam trap discharge at least 12" below the outlet connection on the coil.
- Use float and thermostatic traps in the system, as required by the application.

### O/A Pressure Sensor and Tubing Installation

(All VAV units and all units with Statitrac, see [Figure 22, p. 41](#))

- O/A pressure sensor mounted to the roof bracket.
- Factory supplied pneumatic tubing installed between the O/A pressure sensor and the connector on the base rail.
- Field supplied pneumatic tubing connected to the proper fitting on the space pressure transducer located in the return control panel, and the other end routed to a suitable sensing location within the controlled space.

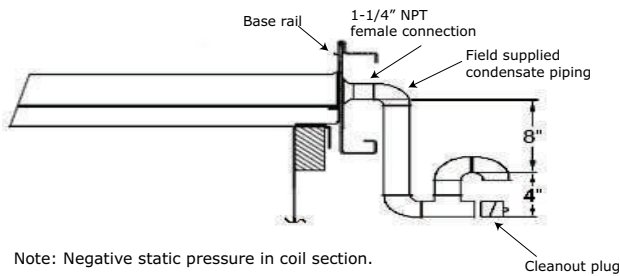
### Condensate Drain Connections

Each unit provides one 1-1/4" evaporator drain connections on each side of the unit.

Due to the size of these units, all condensate drain connections must be connected to the evaporator drain connections.

Refer to Detail A in [Figure 1, p. 15](#) for the location of these drain connections.

A condensate trap must be installed due to the drain connection being on the "negative pressure" side of the fan. Install the P-Traps at the unit using the guidelines in [Figure 1, p. 15](#).

**Figure 21. Condensate trap installation**


Note: Negative static pressure in coil section.

Pitch the drain lines at least 1/2 inch for every 10 feet of horizontal run to assure proper condensate flow. Do not allow the horizontal run to sag causing a possible double-trap condition which could result in condensate backup due to “air lock”.

### Units with Gas Furnace

Units equipped with a gas furnace have a 3/4" CPVC drain connection stubbed out through the vertical support in the gas heat section. It is extremely important that the condensate be piped to a proper drain. Refer to the appropriate illustration in for the location of the drain connection.

**Note:** Units equipped with an optional modulating gas furnace will likely operate in a condensing mode part of the time.

Ensure that all condensate drain line installations comply with applicable building and waste disposal codes.

**Note:** Installation on gas heat units will require addition of heat tape to the condensate drain.

### Removing Compressor Assembly Shipping Hardware

Each manifolded compressor assembly is rigidly bolted to a mounting rail assembly. The rail assembly is set on six (6) rubber isolators. The assembly is held in place by six (6) shipping “Tiedown” bolts. To remove the shipping hardware, follow the procedures below:

1. Remove the bolt in each rubber isolator and the slotted shipping spacer located between the compressor rails and the unit base rail illustrated in . Reinstall the bolts at the same location by screwing them into the base rail two to three turns only.
2. Ensure that the compressor rail assembly is free to move on the rubber isolator.

### Removing Supply and Exhaust Fan Shipping Channels

Each supply fan assembly and exhaust fan assembly is equipped with spring isolators. Shipping channels are installed beneath each fan assembly and must be removed. To locate and remove these channels, refer to and use the following procedures.

### Spring Isolators

Spring isolators for the supply and/or exhaust fan are shipped with the isolator adjusting bolt backed out. Field adjustment is required for proper operation. Shows isolator locations. To adjust the spring isolators use the following procedure.

1. Remove and discard the shipping tie down bolts but leave the shipping channels in place during the adjustment procedure. See .
2. Tighten the leveling bolt on each isolator until the fan assembly is approximately 1/4" above each shipping channel.
3. Secure the lock nut on each isolator.
4. Remove the shipping channels and discard.

### O/A Sensor and Tubing Installation

An Outside Air Pressure Sensor is shipped with all units.

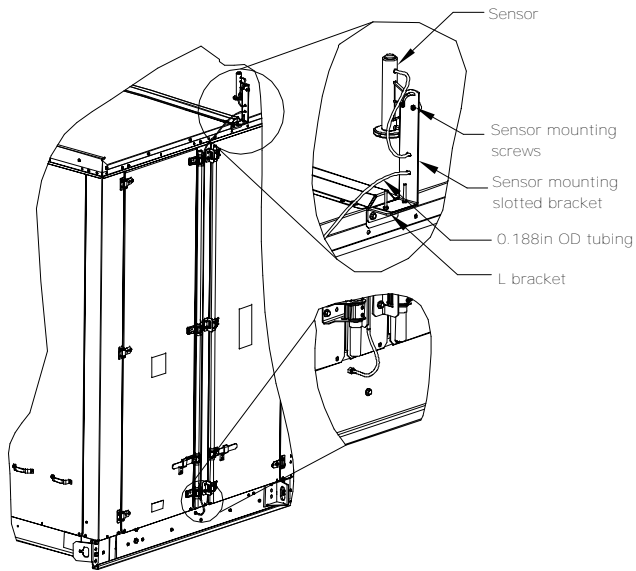
On VAV systems, a duct pressure transducer and the outside air sensor is used to control the discharge duct static pressure to within a customer-specified parameter. On units equipped with 100% modulating relief with Statitrac, a space pressure transducer and the outside air sensor is used to control the relief fan and dampers to relieve static pressure to within a customer-specified parameter, within the controlled space.

Use the following steps and image to install the sensor and the pneumatic tubing.

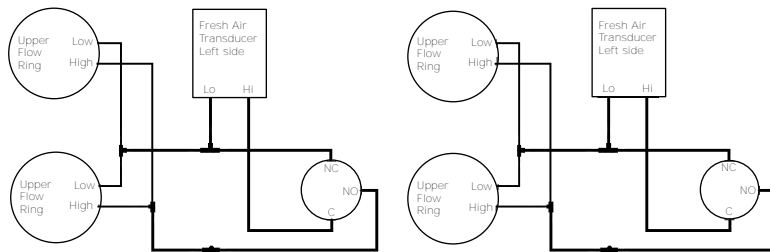
1. Remove the O/A pressure sensor kit located inside the “ship with” item container. The kit contains the following items:
  - a. O/A static pressure sensor with slotted mounting bracket
  - b. 50 ft. 0.188 in tubing
  - c. Mounting hardware
2. Remove the two roof cap screws and install the provided L mounting bracket as shown in the figure.
3. Place the sensor mounting slotted bracket to the L mounting bracket with the slot located to the top.
4. Install the sensor vertically to the slotted bracket and secure it with provided bolt and nut.
5. Connect one end of factory provided tubing to the top port of sensor and pass it through the two slots in the mount and the other end to the port in the base.
6. Secure the tubing with the mounting hardware located in the ship with item container.



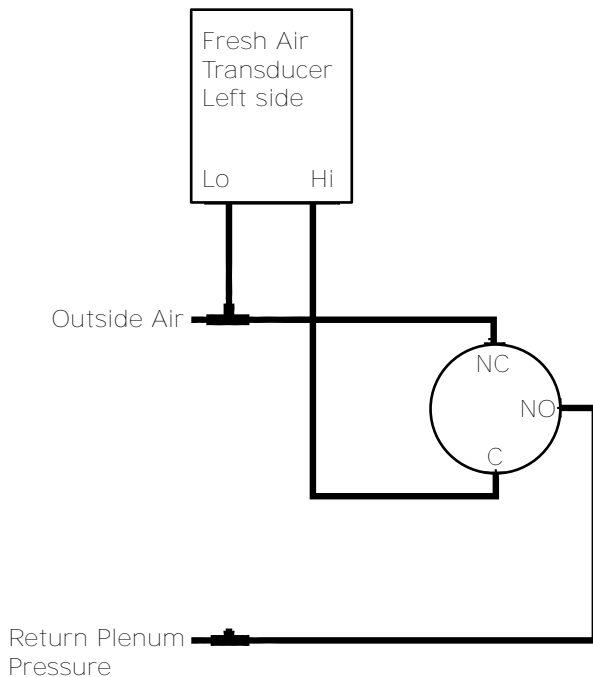
**Figure 22. Outside air sensing kit**



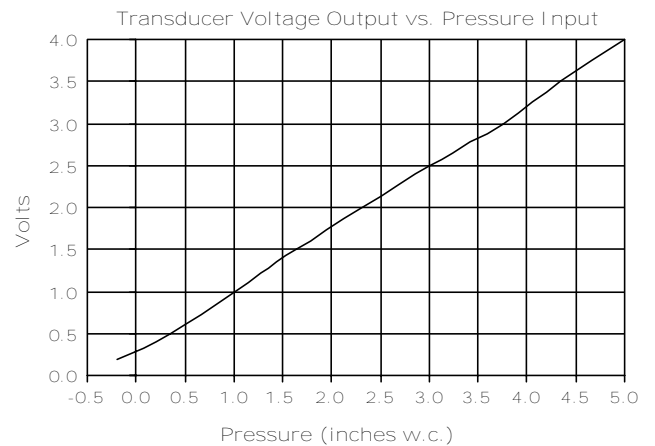
**Figure 23. Outside air tubing schematic**



**Figure 24. Return air pressure tubing schematic**



**Figure 25. Transducer voltage output vs. pressure input with VCM and Traq™ sensing**



**Units with Statitrac**

1. Open the filter access door and locate the Space Pressure and Duct Supply Pressure control devices, see the following image for specific location. There are three tube connectors mounted on the left of the solenoid and transducers.
2. Connect one end of the field provided 1/4" (length 50-



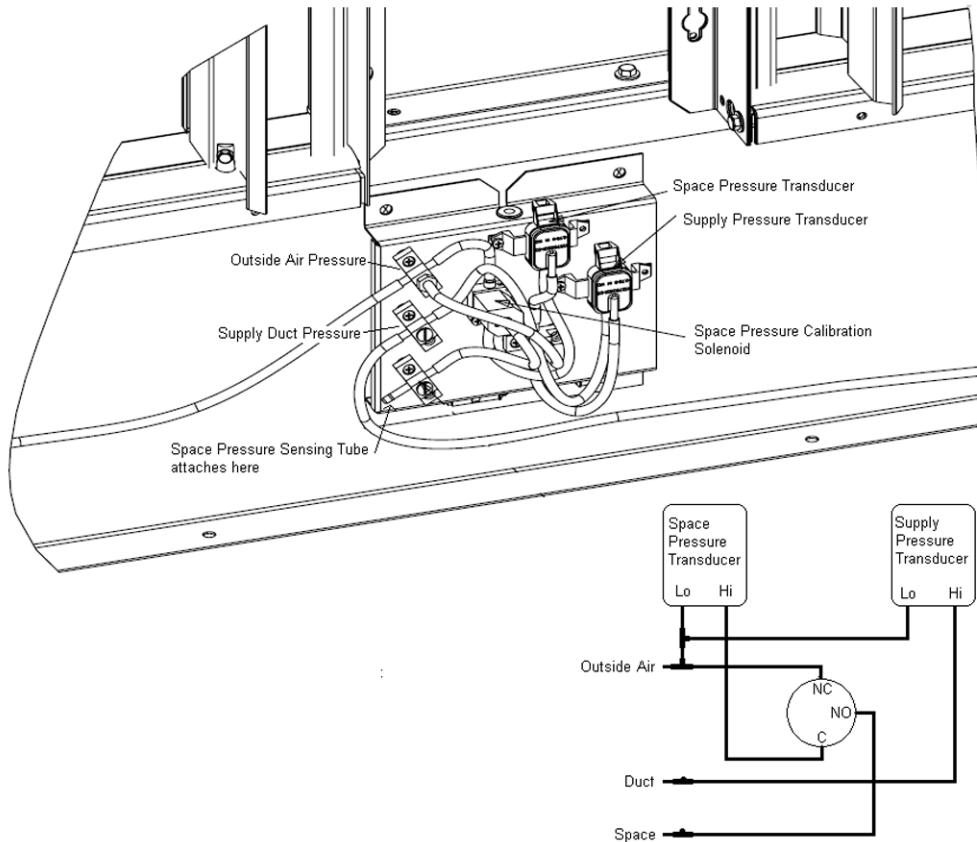
## Installation

100 ft.) or 3/8" (length greater than 100 ft.) O.D. pneumatic tubing for the space pressurization control to the bottom fitting.

3. Route the opposite end of the tubing to a suitable

location inside the building. This location should be the largest open area that will not be affected by sudden static pressure changes.

**Figure 26. Space pressure and duct supply pressure tubing schematic**



## Gas Heat Units

All internal gas piping is factory-installed and pressure leak-tested before shipment. Once the unit is set into place, the gas supply line must be field-connected to the elbow located inside the gas heat control compartments.

### **⚠ WARNING**

#### **Hazardous Gases and Flammable Vapors!**

Failure to observe the following instructions could result in exposure to hazardous gases, fuel substances, or substances from incomplete combustion, which could result in death or serious injury. The state of California has determined that these substances may cause cancer, birth defects, or other reproductive harm.

Improper installation, adjustment, alteration, service or use of this product could cause flammable mixtures or lead to excessive carbon monoxide. To avoid hazardous gases and flammable vapors follow proper installation and setup of this product and all warnings as provided in this manual.

## ⚠ WARNING

### Explosion Hazard!

Failure to properly regulate pressure could result in a violent explosion, which could result in death, serious injury, or equipment or property-only-damage.

When using dry nitrogen cylinders for pressurizing units for leak testing, always provide a pressure regulator on the cylinder to prevent excessively high unit pressures. Never pressurize unit above the maximum recommended unit test pressure as specified in applicable unit literature.

Access holes are provided on the unit as illustrated in to accommodate a side or bottom pipe entry.

Following the guidelines listed below will enhance both the installation and operation of the furnace.

**Note:** In the absence of local codes, the installation must conform with the American National Standard Z223-1a of the National Fuel Gas Code, (latest edition).

1. To assure sufficient gas pressure at the unit, use [Table 13, p. 44](#) as a guide to determine the appropriate gas pipe size for the unit heating capacity listed on the unit nameplate.
2. If a gas line already exists, verify that it is sized large enough to handle the additional furnace capacity before connecting to it.
3. Take all branch piping from any main gas line from the top at 90 degrees or at 45 degrees to prevent moisture from being drawn in with the gas.
4. Ensure that all piping connections are adequately coated with joint sealant and properly tightened. Use a piping compound that is resistant to liquid petroleum gases.
5. Provide a drip leg near the unit.
6. Install a pressure regulator at the unit that is adequate to maintain 7" w.c. for natural gas while the furnace is operating at full capacity.

**Important:** Gas pressure in excess of 14" w.c. or 0.5 psig will damage the gas train.

## NOTICE

### Gas Valve Damage!

Failure to follow instructions below could result in gas valve damage from incorrect gas pressures, irregular pulsating flame patterns, burner rumble, and potential flame outages.

Use a pressure regulator to properly regulate gas pressure. DO NOT oversize the regulator.

Failure to use a pressure regulating device will result in

incorrect gas pressure, which can cause erratic operation due to gas pressure fluctuations as well as damage the gas valve. Oversizing the regulator will cause irregular pulsating flame patterns, burner rumble, potential flame outages, and possible gas valve damage.

If a single pressure regulator serves more than one rooftop unit, it must be sized to ensure that the inlet gas pressure does not fall below 7" w.c. with all the furnaces operating at full capacity. The gas pressure must not exceed 14" w.c. when the furnaces are off.

7. Provide adequate support for all field installed gas piping to avoid stressing the gas train and controls.

## ⚠ WARNING

### Explosion Hazard!

Failure to follow safe leak test procedures below could result in death or serious injury or equipment or property-only-damage.

Never use an open flame to detect gas leaks. Use a leak test solution for leak testing.

8. Leak test the gas supply line using a soap-and-water solution or equivalent before connecting it to the gas train.
9. Check the supply pressure before connecting it to the unit to prevent possible gas valve damage and the unsafe operating conditions that will result.

**Note:** Do not rely on the gas train shutoff valves to isolate the unit while conducting gas pressure/leak test. These valves are not designed to withstand pressures in excess of 14" w.c. or 0.5 psig.

### Connecting the Gas Supply Line to the Furnace Gas Train

Follow the steps below to complete the installation between the supply gas line and the furnace. Refer to [Figure 27, p. 45](#) and [Figure 28, p. 45](#), for the appropriate gas train configuration.

1. Connect the supply gas piping using a "ground-joint" type union to the furnace gas train and check for leaks.
2. Adjust the inlet supply pressure to the recommended 7" to 14" w.c. parameter for natural gas.
3. Ensure that the piping is adequately supported to avoid gas train stress.
4. If the through the base gas opening is used, seal off around the pipe and the 3" water dam. If the through the base gas opening is not used, the 3" opening should be sealed shut to prevent indoor air leakage.



## Installation

**Table 13. Sizing natural gas pipe mains and branches**

Gas Supply Pipe Run (ft)	Gas Input (Cubic Feet/Hour)					
	1¼" Pipe	1½" Pipe	2" Pipe	2½" Pipe	3" Pipe	4" Pipe
10	1,060	1,580	3,050	4,860	8,580	17,500
20	726	1,090	2,090	3,340	5,900	12,000
30	583	873	1,680	2,680	4,740	9,660
40	499	747	1,440	2,290	4,050	8,270
50	442	662	1,280	2,030	3,590	7,330
60	400	600	1,160	1,840	3,260	6,640
70	368	552	1,060	1,690	3,000	6,110
80	343	514	989	1,580	2,790	5,680
90	322	482	928	1,480	2,610	5,330
100	304	455	877	1,400	2,470	5,040
125	269	403	777	1,240	2,190	4,460
150	244	366	704	1,120	1,980	4,050
175	224	336	648	1,030	1,820	3,720
200	209	313	602	960	1,700	3,460

**Notes:**

1. Table is based upon specific gravity of 0.60. Refer to the latest edition of the National Fuel Gas Code, Z223.1, unless superseded by local gas codes.
2. If more than one unit is served by the same main gas supply, consider the total gas input (cubic feet/hr.) and the total length when determining the appropriate gas pipe size.
3. Obtain the Specific Gravity and BTU/Cu.Ft. from the gas company.
4. The following example demonstrates the considerations necessary when determining the actual pipe size:  
 Example: A 40' pipe run is needed to connect a unit with a 850 MBH furnace to a natural gas supply having a rating of 1,000 BTU/Cu.Ft. and a specific gravity of 0.60  
 $\text{Cu.Ft/Hour} = \text{Furnace MBH Input}$   
 $\text{Gas BTU/Cu.Ft.} \times \text{Multiplier Table 14, p. 44}$   
 $\text{Cu.Ft/Hour} = 850$   
 The above table indicates that a 2" pipe is required.

**Table 14. Specific gravity multipliers**

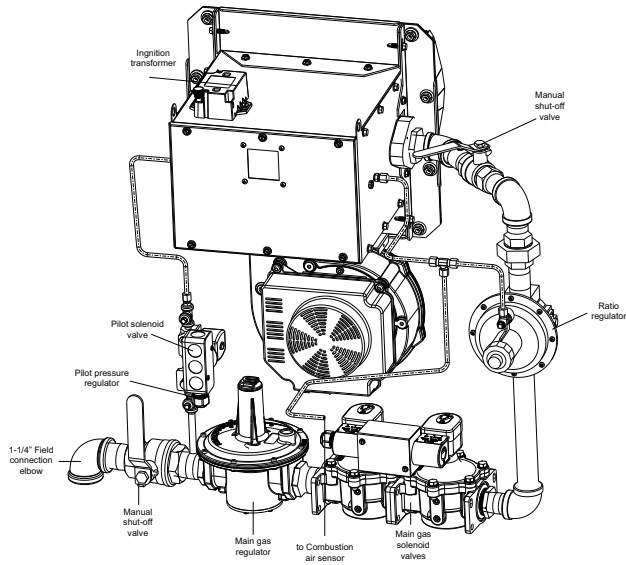
Specific Gravity	Multiplier
0.50	1.10
0.55	1.04
0.60	1.00
0.65	0.96

**Table 15. Gas heating capacity altitude correction factors**

	Altitude (Ft.)						
	Sea Level To 2000	2001 to 2500	2501 to 3500	3501 to 4500	4501 to 5500	5501 to 6500	6501 to 7500
Capacity Multiplier	1.00	.92	.88	.84	.80	.76	.72

**Note:** Correction factors are per ANSI Z223.1/NFPA 54. Local codes may supersede.

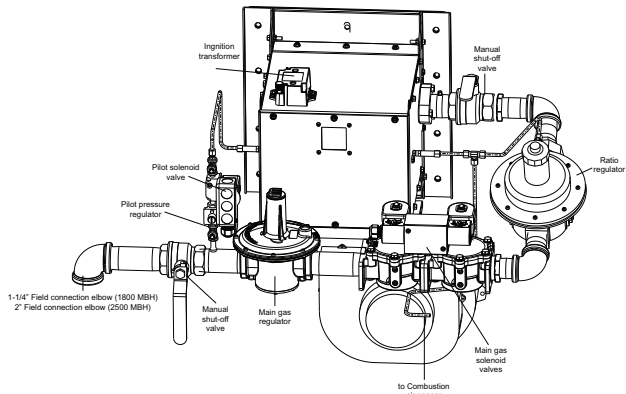
**Figure 27. Two-stage and modulating natural gas train for 850, 1100 MBH heaters**



**Table 16. Gas heat inlet sizes**

Standard Gas Heat Input (MBh)	Gas Heat Inlet Sizes (in.)
850	1 1/4
1100	1 1/4
1800	1 1/2
2500	2

**Figure 28. Two-stage and modulating for 1800, 2500 MBH heaters (1800 MBH shown)**



### Flue Assembly Installation

1. Locate the collapsed flue assembly in the compartment above the gas heat controls by removing the panel screws. The assembly is secured by screws up through the roof of the gas controls compartment roof.
2. Separate the pieces of the collapsed assembly and then assemble the stack as shown in .
3. Insert the tube on the flue assembly into the hole located in the vertical support for the heat section.
4. Butt both tube sections together and center the pipe clamp over joint.
5. Using the pre-punch hole in the flue assembly, extension, and the vertical support, install the appropriate number of mounting brackets (Refer to the installation instructions that ship with the flue assembly.)

Figure 29. Flue assembly

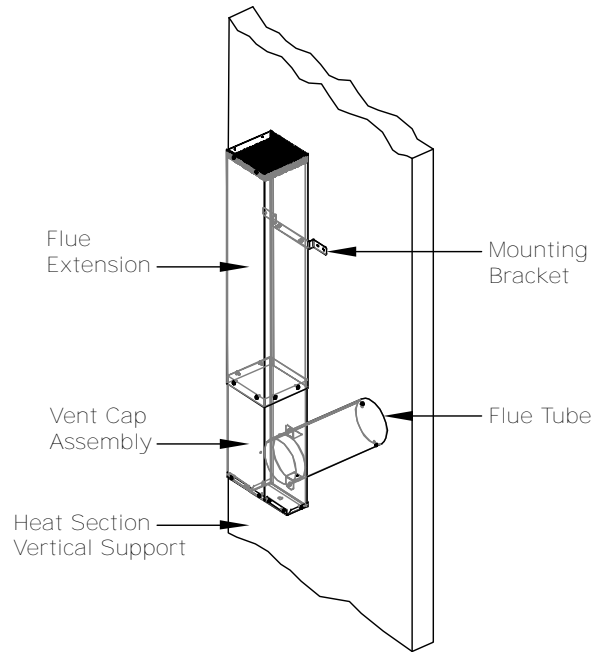
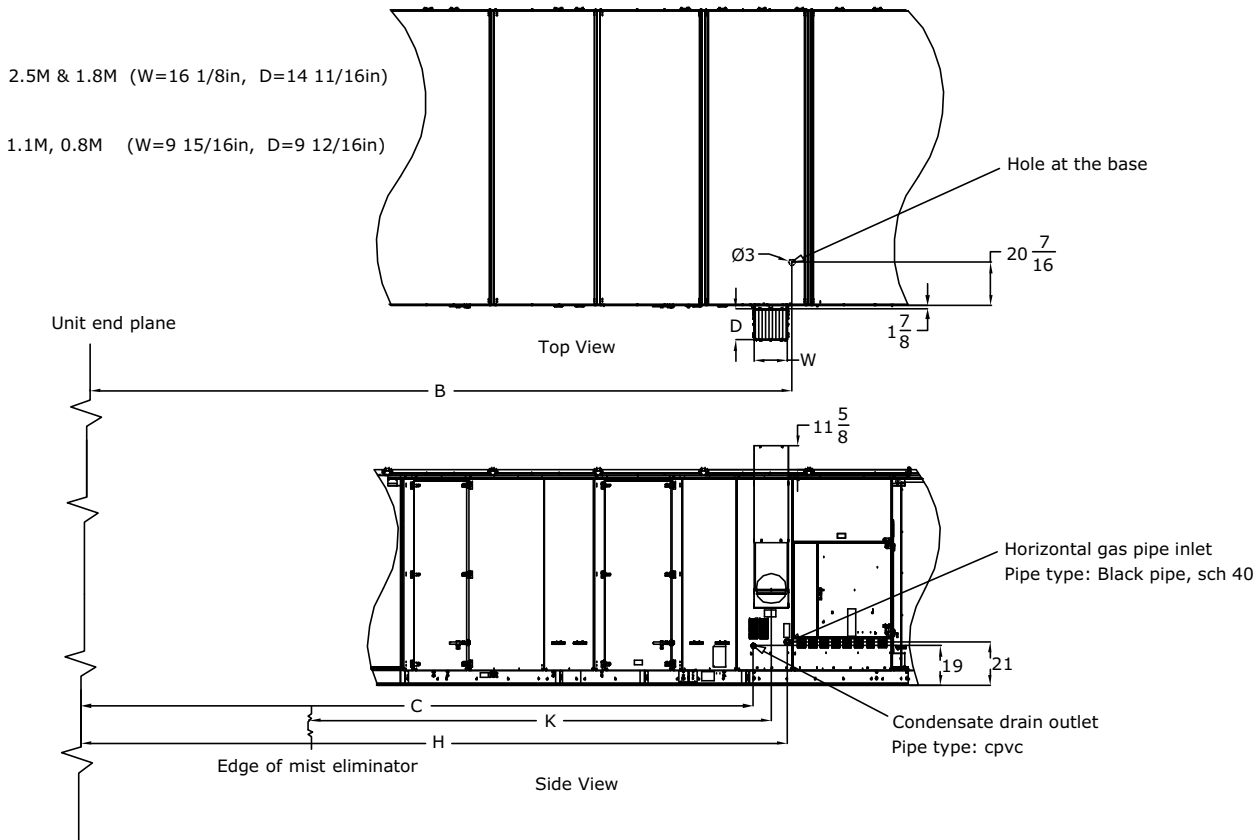


Figure 30. Gas heat piping penetration locations



**Table 17. Gas heat piping penetration measurements**

Tons	Energy Recovery Wheel (ERW)	Pieces	Heat (MBH)	Gas Flue	Condensate Drain Outlet	Gas Connection, Horizontal	Gas Connection, Base
				Horizontal Distance			
				Mist Elim to Flue C/L	Unit End to Hole C/L	Unit End to Hole C/L	
				K	C	H	B
90-105	No ERW	1 & 2 Pc	1800	160 1/16	254 14/16	266 4/16	274 11/16
90-105	No ERW	1 & 2 Pc	1100	159 15/16	263 15/16	265 5/16	274 11/16
90-105	No ERW	1 & 2 Pc	850	159 15/16	263 15/16	265 5/16	274 11/16
120-150	No ERW	1 & 2 Pc	2500	214 11/16	321	337 7/16	339 7/16
120-150	No ERW	1 & 2 Pc	1800	214 13/16	319 11/16	331	339 7/16
120-150	No ERW	1 & 2 Pc	1100	214 11/16	327 14/16	330 1/16	339 7/16
90-105	ERW	1 & 2 Pc	1800	164 11/16	351 5/16	362 10/16	371 1/16
90-105	ERW	1 & 2 Pc	1100	164 8/16	360 6/16	361 12/16	371 1/16
90-105	ERW	1 & 2 Pc	850	164 8/16	360 6/16	361 12/16	371 1/16
120-150	ERW	1 & 2 Pc	2500	219 13/16	417 7/16	433 14/16	435 14/16
120-150	ERW	1 & 2 Pc	1800	220	416 2/16	427 7/16	435 14/16
120-150	ERW	1 & 2 Pc	1100	219 13/16	424 5/16	426 8/16	435 14/16

### General Coil Piping and Connection Recommendations

Proper installation, piping, and trapping is necessary to ensure satisfactory coil operation and to prevent operational damage:

**Note:** The contractor is responsible for supplying the installation hardware.

- Support all piping independently of the coils.
- Provide swing joints or flexible fittings on all connections that are adjacent to heating coils to absorb thermal expansion and contraction strains.
- Install factory supplied control valves (valves ship separately).

**NOTICE**

**Connection Leaks!**  
 Failure to follow instructions below could result in damage to the coil header and cause connection leaks.  
 Use a backup wrench when attaching piping to coils with copper headers. Do not use brass connectors because they distort easily.

- When attaching the piping to the coil header, make the connection only tight enough to prevent leaks. Maximum recommended torque is 200 foot-pounds.

**NOTICE**

**Over Tightening!**  
 Failure to follow instructions below could result in damage to the coil header.  
 Do not use teflon-based products for any field connections because their high lubricity could allow connections to be over tightened.

- Use pipe sealer on all thread connections.

**NOTICE**

**Leakage!**  
 Failure to follow instructions below could result in equipment damage.  
 Properly seal all penetrations in unit casing from inner to outer panel in order to prevent unconditioned air from entering the module, as well as prevent water from infiltrating the insulation.

- After completing the piping connections, seal around pipe from inner panel to outer panel.

### Hot Water Heat Units (SLH\_)

Hot water heating coils are factory installed inside the heater section of the unit. Once the unit is set into place, the hot water piping and the factory provided 3-way modulating valve must be installed. The valve can be installed inside the heat section or near the unit. If the valve is installed in a remote location, use field supplied wiring to extend the control wires from the heater section to the valve. Two access holes are provided in the unit base as



## Installation

illustrated in [Figure 31, p. 49](#).

Use the following guidelines to enhance both the installation and operation of the “wet heat” system.

[Figure 32, p. 49](#) illustrates the recommended piping configuration for the hot water coil. [Table 18, p. 49](#) lists the coil connection sizes.

**Note:** *The valve actuators are not waterproof. Failure to protect the valve from moisture may result in the loss of heating control.*

1. Support all field-installed piping independently from the heating coil.
2. Use swing joints or flexible connectors adjacent to the heating coil. (These devices will absorb the strains of expansion and contraction).
3. All return lines and fittings must be equal to the diameter of the “outlet” connection on the hot water coil.
4. Install a “Gate” type valve in the supply branch line as close as possible to the hot water main and upstream of any other device or takeoff.
5. Install a “Gate” type valve in the return branch line as close as possible to the return main and down stream of any other device.
6. Install a strainer in the hot water supply branch as shown in [Figure 32, p. 49](#).
7. Install the 3-way valve in an upright position, piped for valve seating against the flow. Ensure that the valve location lends itself to serviceability.
8. The Type “W” hot water coil is self-venting only when the tube water velocity exceeds 1.5 feet per second (fps). If the tube velocity is less than 1.5 feet per second, either:
  - a. install an automatic air vent at the top of the return header, using the tapped pipe connection
  - or,
  - b. vent the coil from the top of the return header down to the return piping. At the vent connection, size the return piping to provide sufficient water velocity.
9. Install a “Globe” type valve in the Bypass line as shown in [Figure 32, p. 49](#).

### Steam Heat Units

Steam heating coils are factory installed inside the heater section of the unit. The coils are pitched within the units to provide the proper condensate flow from the coil. To maintain the designed degree of pitch for the coil, the unit must be level.

Once the unit is set into place, the steam piping and the factory provided 2-way modulating valve must be installed. The valve can be installed inside the heater section or near the unit. If the valve is installed in a remote location, use field supplied wiring to extend the control wires from the heater section to the valve. Two access holes are provided in the unit base as illustrated in [Figure 31, p. 49](#).

Use the following guidelines to enhance both the

installation and operation of the “wet heat” system. [Figure 33, p. 50](#) illustrates the recommended piping configurations for the steam coil. [Table 18, p. 49](#) lists the coil connection sizes.

**Note:** *The valve actuators are not waterproof. Failure to protect the valve from moisture may result in the loss of heating control.*

1. Support all field-installed piping independently from the heating coil.
2. Use swing joints or flexible connectors adjacent to the heating coil. (These devices will absorb the strains of expansion and contraction.)
3. Install the 2-way valve in an upright position. Ensure that the valve’s location lends itself to serviceability.
4. Pitch the supply and return steam piping downward 1" per 10' of run in the direction of flow.
5. All return lines and fittings must be equal to the diameter of the “outlet” connection on the steam coil(s). If the steam trap connection is smaller than the coil “outlet” diameter, reduce the pipe size between the strainer and the steam trap connections only.
6. Install a 1/2" 15 degree swing-check vacuum breaker at the top of the return coil header using the tapped pipe connection. Position the vacuum breaker as close to the coil as possible.

**Note:** *Vacuum breakers should have extended lines from the vent ports to the atmosphere or connect each vent line to the return pipe on the discharge side of the steam traps.*

7. Install a “Gate” type valve in the supply branch line as close as possible to the steam main and upstream of any other device.
8. Install a “Gate” type valve in the return branch line as close as possible to the condensate return main and downstream of any other device.
9. Install a strainer as close as possible to the inlet of the control valve and steam trap(s). Steam trap selection should be based on the maximum possible condensate flow and the recommended load factors.
10. Install a Float-and-Thermostatic (FT) type trap to maintain proper flow. It provides gravity drains and continuous discharge operation. FT type traps are required if the system includes either of the following:
  - a. an atmospheric pressure/gravity condensate return
  - or
  - b. a potentially low pressure steam supply.
11. Position the outlet or discharge port of the steam trap at least 12" below the outlet connection on the coil(s). This will provide adequate hydrostatic head pressure to overcome the trap losses and assure complete condensate removal.

If two steam coils are stacked together, they must be piped in a parallel arrangement. The steps listed below should be used in addition to the previous steps. [Figure](#)



33, p. 50 illustrates the recommended piping configuration for the steam coils.

- Install a strainer in each return line before the steam trap.
- Trap each steam coil separately as described in [Step 10 Installation\\_Steam Heat Units](#) and [Step 11 Installation\\_Steam Heat Units](#) to prevent condensate backup in one or both coils.
- In order to prevent condensate backup in the piping header supplying both coil sections, a drain must be installed utilizing a strainer and a steam trap as illustrated in [Figure 33, p. 50](#).

**Table 18. Hot water and steam coil connection sizes**

Unit Size	Hot Water Coil			Steam Coil		
	Supply	Return	Drain/Vent	Supply	Return	Vent
90-150 Ton	2 ½	2 ½	½	3.0	1 ¼	1 ¼

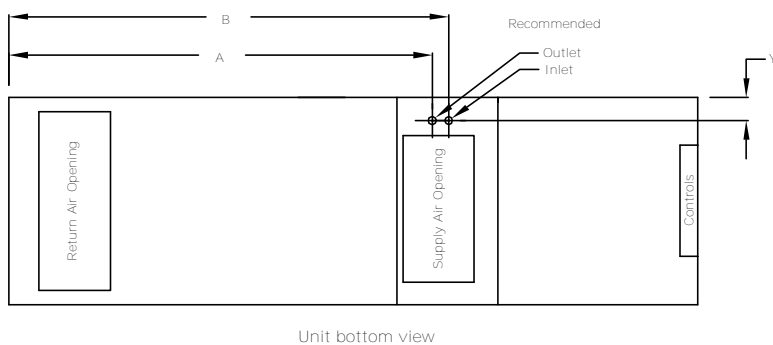
**Notes:**

- Type W coils, with center offset headers, are used in Hot Water units; Type NS coils are used in Steam units.
- Hot water and Steam units have multiple headers.
- All sizes are in inches.
- All connection threads are internal.

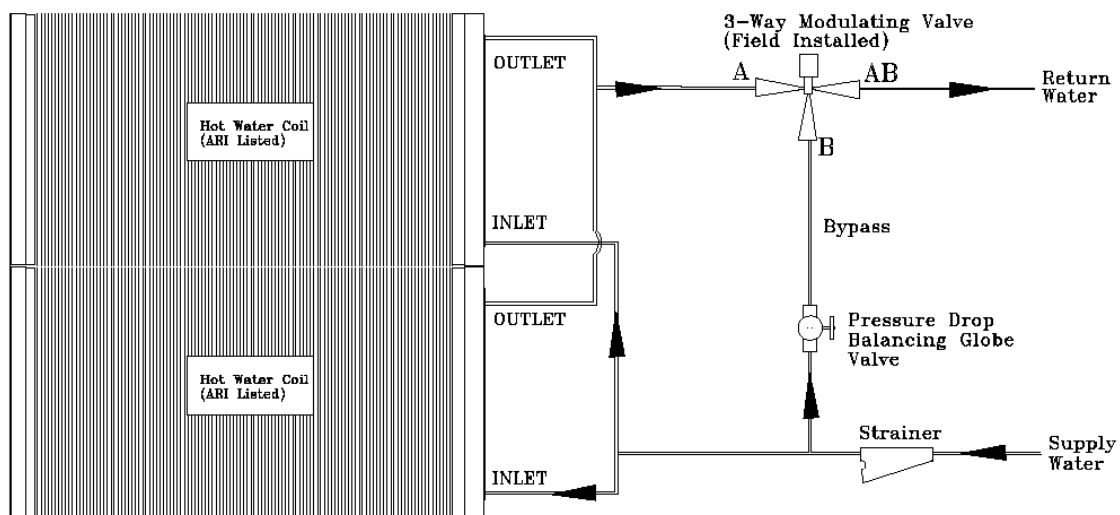
**Table 19. Hot water and steam heat connection dimensions**

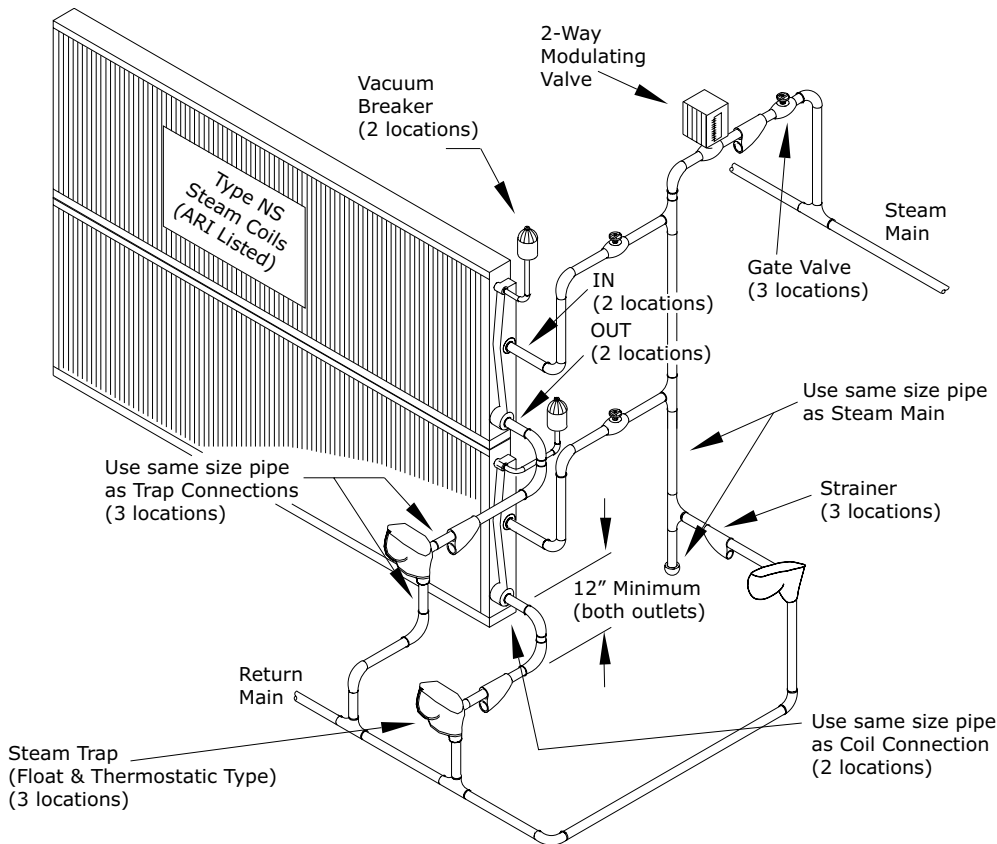
Tons	A	B	Y	Diameter
90-105	276 9/16	290 5/16	18	5
120-150	341 5/16	355 1/16	18	5

**Figure 31. Hot water and steam heat connection location**



**Figure 32. Hot water coil piping**



**Figure 33. Steam coil piping**


### Disconnect Switch with External Handle

Units come equipped with a factory mounted disconnect switch with an externally mounted handle. This allows the operator to disconnect power from the unit without having to open the control panel door. The handle has three positions:

- “ON” - Indicates that the disconnect switch is closed, allowing the main power supply to be applied at the unit.
- “OFF” - Indicates that the disconnect switch is open, interrupting the main power supply to the unit controls.
- “RESET/LOCK” - Turning the handle to this position resets or disconnects the device. To disconnect, the handle must be turned to the Reset/Lock position. Pulling the spring-loaded thumb key out, so the lock shackle can be placed between the handle and the thumb key, locks the handle so the unit cannot be energized.

### **⚠ WARNING**

#### **Hazardous Voltage w/Capacitors!**

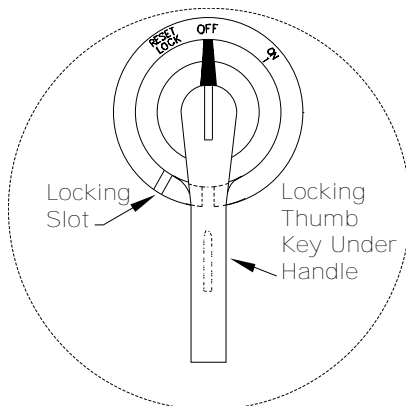
**Failure to disconnect power and discharge capacitors before servicing could result in death or serious injury.**

**Disconnect all electric power, including remote disconnects and discharge all motor start/run capacitors before servicing. Follow proper lockout/tagout procedures to ensure the power cannot be inadvertently energized. For variable frequency drives or other energy storing components provided by Trane or others, refer to the appropriate manufacturer’s literature for allowable waiting periods for discharge of capacitors. Verify with a CAT III or IV voltmeter rated per NFPA 70E that all capacitors have discharged.**

The handle can be locked in the “OFF” position by completing the following steps (see [Figure 34, p. 51](#)):

1. While holding the handle in the “OFF” position, push the spring loaded thumb key, attached to the handle, into the base slot.
2. Place the lock shackle between the handle and the thumb key. This will prevent it from springing out of position.

**Figure 34. Disconnect switch external handle**



**Note:** All field installed wiring must conform to NEC guidelines as well as State and Local codes.

An overall layout of the field required power wiring is illustrated in . To ensure that the unit supply power wiring is properly sized and installed, follow these guidelines:

### ⚠ WARNING

#### Live Electrical Components!

Failure to follow all electrical safety precautions when exposed to live electrical components could result in death or serious injury.

When it is necessary to work with live electrical components, have a qualified licensed electrician or other individual who has been properly trained in handling live electrical components perform these tasks.

### NOTICE

#### Use Copper Conductors Only!

Failure to use copper conductors could result in equipment damage as the equipment was not designed or qualified to accept other types of conductors.

- Verify that the power supply available is compatible with the unit nameplate rating for all components. The available power supply must be within 10% of the rated voltage stamped on the nameplate.
- Use only copper conductors to connect the 3-phase power supply to the unit.

## Electric Heat Units

Electric Heat Units require one power entry as illustrated in .

Use the information provided in Service Sizing data and the “Power Wire Sizing & Protection Device Equations,” to determine the appropriate wire size and Maximum Over current Protection for the heaters/unit.

**Note:** Each power supply must be protected from short circuit and ground fault conditions. To comply with NEC, protection devices must be sized according to the “Maximum Over current Protection” (MOP) or “Recommended Dual Element” (RDE) fuse size data on the unit nameplate.

Provide grounding for the supply power circuit in the electric heat control box.

## Main Unit Power Wiring

and lists the field connection wire ranges for both the main power terminal block and the optional main power disconnect switch. The electrical tables beginning with list the component electrical data.

The electrical service must be protected from over current and short circuit conditions in accordance with NEC requirements. Protection devices must be sized according to the electrical data on the nameplate. Refer to the equations listed in the product catalog to determine the following:

- the appropriate electrical service wire size based on “Minimum Circuit Ampacity” (MCA)
- the “Maximum Over Current Protection” (MOP) device

### ⚠ WARNING

#### Proper Field Wiring and Grounding Required!

Failure to follow code could result in death or serious injury.

All field wiring **MUST** be performed by qualified personnel. Improperly installed and grounded field wiring poses **FIRE** and **ELECTROCUTION** hazards. To avoid these hazards, you **MUST** follow requirements for field wiring installation and grounding as described in NEC and your local/state/national electrical codes.

The location of the electrical service entrance is illustrated in . It is important to complete the unit power wiring connections onto either the main terminal block or the factory mounted, non-fused disconnect switch. The disconnect switch is inside the unit control panel .Refer to the diagrams that shipped with the unit for specific termination points.

Provide proper grounding for the unit in accordance with local and national codes.

Figure 35. Typical field power wiring (front view)

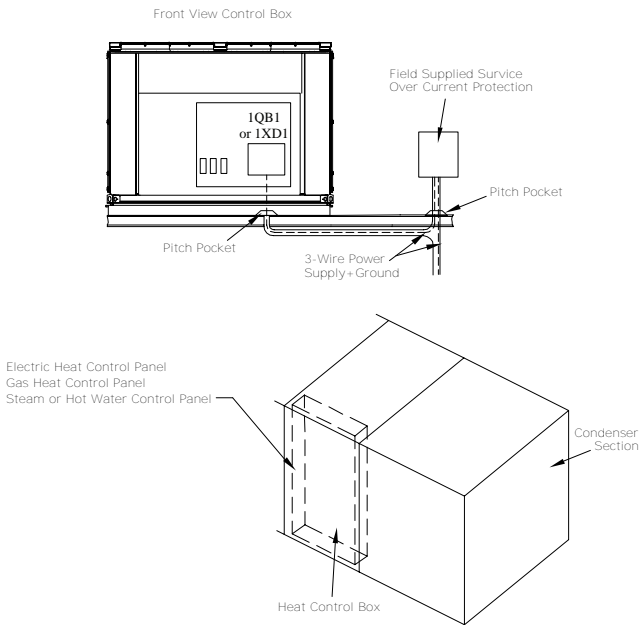


Table 20. Customer connection wire range

Units with Main Power Terminal Block		
Block Size	Wire Qty Per Phase	Connector Wire Range
760 Amp	2	4 AWG - 500 kcmil
Units with Main Power Disconnect Switch (Standard and High SCCR)		
Switch Size	Wire Qty Per Phase	Connector Wire Range
250 Amp	1	3/0 AWG - 350 kcmil <sup>(a)</sup>
400 Amp	2	2/0 AWG - 500 kcmil
600 Amp	2	2/0 AWG - 500 kcmil
800 Amp	3	3/0 AWG - 500 kcmil

**Note:** Non-fused disconnect switch size is calculated by selecting the size greater than or equal to 1.15 X (sum of unit loads). See unit literature for unit load values. See following page for circuit breaker sizing.

<sup>(a)</sup> 250A Disconnect Switches can accommodate 4 AWG - 4/0 AWG if Lug Screws are changed to S1A5955 kit (Provided with Unit)

250A Disconnect switch wire binding screws

The 250A disconnect switch (standard and high SCCR) installed for main power connection accommodates 4 AWG– 350 kcmil wires on the "OFF" side. As shipped from the factory, the wire binding screws only accommodate 3/0 AWG – 350 kcmil wires. If 4 AWG – 2/0 AWG field power wiring is used, then the factory installed wire binding screws must be replaced with those that are provided with the kit installed near the disconnect switch (these screws should have a blue top surface). See the kit for instructions on changing the wire binding screws.

Electrical Service Sizing

To correctly size electrical service wiring for a unit, find the appropriate calculations listed below. Each type of unit has its own set of calculations for MCA (Minimum Circuit Ampacity) and MOP (Maximum Overcurrent Protection). Read the load definitions that follow and then find the appropriate set of calculations based on unit type.

**Note:** Set 1 is for cooling only and cooling with gas heat units, and set 2 is for cooling with electric heat units.

Load Definitions: (To determine load values, see the Electrical Service Sizing Data Tables on the following page.)

LOAD1 = Current of the largest motor (compressor or fan motor)

LOAD2 = Sum of the currents of all remaining motors

LOAD3 = Current of electric heaters

LOAD4 = Any other load rated at 1 AMP or more

Set 1: Cooling Only Rooftop Units and Cooling with Gas Heat Rooftop Units

$$MCA = (1.25 \times LOAD1) + LOAD2 + LOAD4$$

$$MOP = (2.25 \times LOAD1) + LOAD2 + LOAD4$$

Select a fuse rating equal to the MOP value. If the MOP value does not equal a standard fuse size as listed in NEC 240-6, select the next lower standard fuse rating.

**Note:** If selected MOP is less than the MCA, then select the lowest standard maximum fuse size which is equal to or larger than the MCA, provided the selected fuse size does not exceed 800 amps.

## Set 2: Rooftop units with Electric Heat

To arrive at the correct MCA and MOP values for these units, two sets of calculations must be performed. First calculate the MCA and MOP values as if the unit was in cooling mode (use the equations given in Set 1). Then calculate the MCA and MOP values as if the unit were in heating mode as follows. (Keep in mind when determining LOADS that the compressors don't run while the unit is in heating mode).

$$\text{MCA} = 1.25 \times (\text{LOAD1} + \text{LOAD2} + \text{LOAD4}) + \text{LOAD3}$$

The nameplate MCA value will be the larger of the cooling mode MCA value or the heating mode MCA value calculated above.

$$\text{MOP} = (2.25 \times \text{LOAD1}) + \text{LOAD2} + \text{LOAD3} + \text{LOAD4}$$

The selection MOP value will be the larger of the cooling mode MOP value or the heating mode MOP value calculated above.

Select a fuse rating equal to the MOP value. If the MOP value does not equal a standard fuse size as listed in NEC 240-6, select the next lower standard fuse rating.

### Notes:

- If selected MOP is less than the MCA, then select the lowest standard maximum fuse size which is equal to or larger than the MCA, provided the selected fuse size does not exceed 800 amps.
- On 90 to 150 ton rooftops, the selected MOP value is stamped in the MOP field on the unit nameplate.

### Service Sizing Data

**Table 21. Electrical service sizing data**

Fixed Capacity Compressors								
Nom Tons	Compressor		Nominal Voltage					
	Size	No per Unit	460 V		575 V		380 V	
			RLA (ea.)	LRA (ea.)	RLA (ea.)	LRA (ea.)	RLA (ea.)	LRA (ea.)
90	250	4	38.1	215	30.4	175	38.4	215
105	184	6	28.9	160	23.1	135	29.1	160
120	184	4	28.9	160	23.1	135	29.1	160
	250	2	38.1	215	30.4	175	38.4	215
130	240	6	36	215	28.8	175	36.3	215
150	250	6	38.1	215	30.4	175	38.4	215

**Table 22. Electrical service sizing data**

Fixed Capacity Compressors								
Nom Tons	Compressor		Nominal Voltage					
	Size	No per Unit	460 V		575 V		380 V	
			RLA (ea.)	LRA (ea.)	RLA (ea.)	LRA (ea.)	RLA (ea.)	LRA (ea.)
90	170	1	44.6	N/A	35.7	N/A	54	N/A
	169	4	26.2	160	20.9	135	26.4	160
105	170	1	44.6	N/A	35.7	N/A	54	N/A
	169	3	26.2	160	20.9	135	26.4	160
	227	1	36.1	215	28.9	175	36.4	215
120	170	1	44.6	N/A	35.7	N/A	54	N/A
	169	2	26.2	160	20.9	135	26.4	160
	227	1	36.1	160	28.9	175	36.4	215
	285	1	47.5	260	38	210	48	260
130	170	1	44.6	N/A	35.7	N/A	54	N/A
	227	3	36.1	215	28.9	175	36.4	215
	346	1	57.1	235	45.6	187	57.6	235



**Installation**

**Table 22. Electrical service sizing data (continued)**

Nom Tons	Compressor		Nominal Voltage					
	Size	No per Unit	460 V		575 V		380 V	
			RLA (ea.)	LRA (ea.)	RLA (ea.)	LRA (ea.)	RLA (ea.)	LRA (ea.)
150	170	1	44.6	N/A	35.7	N/A	54	N/A
	169	1	26.2	160	20.9	135	26.4	160
	227	1	36.1	215	28.9	175	36.4	215
	346	2	57.1	235	45.6	187	57.6	235

**Table 23. Electrical service sizing data—motors — air-cooled and evaporative condensing**

Nominal Tonnage	No of Fans	Fixed Speed						Variable Speed		
		Standard Ambient			Low Ambient			Standard or Low Ambient		
		Voltage								
		460	575	380	460	575	380	460	575	380
90, 105	6	16.2	13.2	15	15	12.4	14.8	12.5	10.8	14.3
120, 130, 150	8	21.6	17.6	20	20.4	16.8	19.8	16.6	14.4	19.1

**Table 24. Electrical service sizing data—supply, relief/return fan motors — air-cooled and evaporative condensing**

Motor HP	460 V	575 V	380 V
	FLA	FLA	FLA
<b>Supply Fan Motors</b>			
15	18.5	15.0	22.0
20	24.7	19.6	28.0
25	31.0	25.0	36.0
30	36.6	29.0	43.5
40	49.0	39.0	54.0
50	59.0	47.2	68.0
60	71.5	57.2	81.0
75	90.0	72.0	103.0
100	115.0	91.3	N/A
<b>Relief/Return Fan Motors</b>			
7.5	9.8	7.8	12.1
10	12.6	10.1	15.2
15	18.5	15.0	22.0
20	24.7	19.6	28.0
25	31.0	25.0	36.0
30	36.6	29.0	43.5
40	49.0	39.0	54.0
50	59.0	47.2	68.0
60	71.5	57.2	81.0

**Table 25. Electrical service sizing data—electric heat module (electric heat units only)**

Module kW	Voltage		
	460	575	380
	FLA	FLA	FLA
90 / 56	108.3	86.6	85.1
140 / 88	168.4	134.7	133.3
265 / 166	318.8	255.0	252.3
300 / 188	360.8	288.7	285.7

**Note:** Electric heat FLA are determined at 480, 600, 380 volts.



## Installation

---

**Table 26. Transformer 1 and 2 primary amps**

Nom Tons	Voltage		
	460	575	380
90–150	9	7	11

**Table 27. Voltage utilization range**

Unit Voltage	Range
460/60/3	414-506
575/60/3	517-633
380/50/3	342-418

**Table 28. Electrical service sizing data—energy recovery wheel motor**

Nom Tons	Unit Function	Voltage	
		460	575
		FLA	FLA
90-120	1 (Low CFM ERW)	1.1	0.90
130-150	1 (Low CFM ERW)	1.8	1.4
All	2 (High. CFM ERW)	2.6	2.5



## Field Installed Control Wiring

The Symbio™ 800 must have a mode input in order to operate the rooftop unit. The flexibility of having several system modes depends upon the type of sensor and/or remote panel selected to interface with the The Symbio™ 800. An overall layout of the various control options available, with the required number of conductors for each device, is illustrated beginning with .

**Note:** All field wiring must conform to NEC guidelines as well as state and local codes.

### ⚠ WARNING

#### Hazardous Voltage!

Failure to disconnect power before servicing could result in death or serious injury.

Disconnect all electric power, including remote disconnects before servicing. Follow proper lockout/tagout procedures to ensure the power can not be inadvertently energized. Verify that no power is present with a voltmeter.

### ⚠ WARNING

#### Proper Field Wiring and Grounding Required!

Failure to follow code could result in death or serious injury.

All field wiring MUST be performed by qualified personnel. Improperly installed and grounded field wiring poses FIRE and ELECTROCUTION hazards. To avoid these hazards, you MUST follow requirements for field wiring installation and grounding as described in NEC and your local/state/national electrical codes.

The various field installed control panels, sensors, switches, and contacts discussed in this section require both AC and DC consideration. These diagrams are representative of standard applications and are provided for general reference only. Always refer to the wiring diagram that shipped with the unit for specific electrical schematic and connection information.

## Controls using 24 VAC

Before installing any connecting wiring, refer to [Figure 3, p. 21](#) for the electrical access locations provided on the unit, and [Table 29, p. 57](#) for AC conductor sizing guidelines. Then check the following:

### NOTICE

#### Use Copper Conductors Only!

Failure to use copper conductors could result in equipment damage as the equipment was not designed or qualified to accept other types of conductors.

1. Use copper conductors unless otherwise specified.

2. Ensure that the AC control wiring between the controls and the unit's termination point does not exceed three (3) ohms/conductor for the length of the run.

**Note:** Resistance in excess of 3 ohms per conductor may cause component failure due to insufficient AC voltage supply.

3. Make sure to check all loads and conductors for grounds, shorts, and mis-wiring.

**Table 29. AC conductors**

Distance from Unit to Control	Recommended Wire Size
000-460 feet	18 gauge
461-732 feet	16 gauge
733-1000 feet	14 gauge

4. Do not run the AC low voltage wiring in the same conduit with the high voltage power wiring.

## Controls using DC Analog Input/Outputs

Before installing any connecting wiring between the unit and components utilizing a DC analog input/output signal, refer to the appropriate illustration in [Figure 3, p. 21](#) for the electrical access locations provided on the unit and [Table 30, p. 57](#) for conductor sizing guidelines. Then check the following:

### NOTICE

#### Use Copper Conductors Only!

Failure to use copper conductors could result in equipment damage as the equipment was not designed or qualified to accept other types of conductors.

1. Use standard copper conductor thermostat wire unless otherwise specified.
2. Ensure that the wiring between the controls and the unit termination point does not exceed two and a half (2.5) ohms/conductor for the length of the run.

**Note:** Resistance in excess of 2.5 ohms per conductor can cause deviations in the accuracy of the controls.

**Table 30. DC conductors**

Distance from Unit to Control	Recommended Wire Size
000-150 feet	22 gauge
151- 240 feet	20 gauge
241- 385 feet	18 gauge
386- 610 feet	16 gauge
611- 970 feet	14 gauge

3. Do not run the electrical wires transporting DC signals in or around conduit housing high voltage wires. Units wired for a BACnet® Communication, LonTalk®



## Installation

communication Interface, or Modbus option which utilizes a serial communication link must:

- be 18 AWG shielded twisted pair cable (Belden 8760 or equivalent).
- not exceed 5,000 feet maximum for each link.
- not pass between buildings.

### Constant Volume Zone Panel (BAYSENS108\*)

This electronic sensor features four system switch settings (Heat, Cool, Auto, and Off) and two fan settings (On and Auto). It is a manual or automatic changeover control with dual setpoint capability.

### Variable Air Volume System Controls

#### VAV Changeover Contacts

The changeover input is used with modulating gas heat, electric heat, or hydronic heat. When the contacts are closed, the unit will control to the discharge heating setpoint. Refer to the unit wiring diagram for the field connection terminals in the unit control panel. The switch must be rated at 12 ma @ 24 VDC minimum.

### Variable Air Volume System Controls

#### Remote Zone Sensor (BAYSENS073\*)

This electronic analog sensor features remote zone sensing and timed override with override cancellation. It is used as the source for zone temperature control. Refer to [Table 31, p. 60](#) for the Temperature vs. Resistance coefficient.

#### Remote Zone Sensor (BAYSENS074\*)

This electronic analog sensor features single setpoint capability and timed override with override cancellation. It is used with a Trane Integrated Comfort™ system. Refer to [Table 31, p. 60](#) for the Temperature vs. Resistance coefficient.

### CO<sub>2</sub> Sensing—Space or Duct

The CO<sub>2</sub> sensor shall have the ability to monitor space occupancy levels within the building by measuring the parts per million of CO<sub>2</sub> in the air. As the CO<sub>2</sub> levels increase, the outside air damper modulates to meet the CO<sub>2</sub> space ventilation requirements.

### Stop/Off/Auto

The Symbio™ 800 controller will stop or turn off the IntelliPak unit for a number of reasons. The user interface home screen displays unit mode of Stopped or Auto. Stopped is indicated when an override is preventing operation such as: Local Stop, Emergency Stop or Equipment Stop input is active. Auto is indicated when in automatic control but is currently off in modes such as: Unoccupied, Ventilation Override, or Emergency Override.

When Heat Cool Mode Status is Off, unit operation will be prevented; whereas, all other modes allow operation.

### Emergency Override

When a Lontalk®/BACnet® communication module is installed, the user can initiate from the Trane Tracer® Summit or 3rd party BAS one of five (5) predefined, not available to configure, Emergency Override sequences. All compressors, condenser fans and the Humidification output are deenergized for any Emergency Override sequence. Each Emergency Override sequence commands the unit operation as follows:

- **PRESSURIZE\_EMERG**
  - Supply Fan - On
  - Supply Fan VFD Open/Max (if so equipped)
  - Exhaust Fan - Off; Exhaust Dampers Closed (if so equipped)
  - OA Dampers - Open; Return Damper - Closed
  - Heat - All heat stages off; Mod Heat output at 0 VDC
  - Occupied/Unoccupied/VAV box output - Energized
  - VOM Relay - Energized (if so equipped)
  - Preheat Output - Off
  - Return Fan - Off; Exhaust Dampers - Closed (if so equipped)
  - Return VFD - Min (if so equipped)
- **EMERG\_DEPRESSURIZE**
  - Supply Fan - Off
  - Supply Fan VFD - Closed/Min (if so equipped)
  - Exhaust Fan - On; Exhaust Dampers Open/Max (if so equipped)
  - OA Dampers - Closed; Return Damper - Open
  - Heat - All heat stages off; Mod Heat output at 0 VDC
  - Occupied/Unoccupied/VAV box output - Energized
  - VOM Relay - Energized (if so equipped)
  - Preheat Output - Off
  - Return Fan - On; Exhaust Dampers - Open (if so equipped)
  - Return VFD - Max (if so equipped)
- **EMERG\_PURGE**
  - Supply Fan - On
  - Supply Fan VFD - Open/Max (if so equipped)
  - Exhaust Fan - On; Exhaust Dampers Open (if so equipped)
  - OA Dampers - Open; Return Damper - Closed
  - Heat - All heat stages off; Mod Heat output at 0 VDC
  - Occupied/Unoccupied/VAV box output - Energized
  - VOM Relay - Energized (if so equipped)
  - Preheat Output - Off
  - Return Fan - On; Exhaust Dampers - Open (if so equipped)
  - Return VFD - Max (if so equipped)
- **EMERG\_SHUTDOWN**

- Supply Fan - Off
  - Supply Fan VFD - Closed/Min (if so equipped)
  - Exhaust Fan - Off; Exhaust Dampers Closed (if so equipped)
  - OA Dampers - Closed; Return Damper - Open
  - Heat - All heat stages off; Mod Heat output at 0 VDC
  - Occupied/Unoccupied/VAV box output - Energized
  - VOM Relay - Energized (if so equipped)
  - Preheat Output - Off
  - Return Fan - Off; Exhaust Dampers - Closed (if so equipped)
  - Return VFD - Min (if so equipped)
- **EMERG\_FIRE - Input from fire pull box/system**
    - Supply Fan - Off
    - Supply Fan VFD - Closed/Min (if so equipped)
    - Exhaust Fan - Off; Exhaust Dampers Closed (if so equipped)
    - OA Dampers - Closed; Return Damper - Open
    - Heat - All heat stages off; Mod Heat output at 0 VDC
    - Occupied/Unoccupied/VAV box output - Energized
    - VOM Relay - Energized (if so equipped)
    - Preheat Output - Off
    - Return Fan - Off; Exhaust Dampers - Closed (if so equipped)
    - Return VFD - Min (if so equipped)

## Ventilation Override Module (VOM)

**Important:** *The ventilation override system should not be used to signal the presence of smoke caused by a fire, as it is not intended nor designed to do so.*

The user can customize up to five (5) different override sequences for purposes of ventilation override control. If more than one VOM sequence is being requested, the sequence with the highest priority is initiated first. Sequence hierarchy is the sequence "A" (UNIT OFF) is first, with sequence "E" (PURGE with Duct Pressure Control) last. A ventilation override mode can be initiated by closing any of the five (5) corresponding binary inputs on the VOM module. A binary output is provided on the VOM module to provide remote indication of an active VOM mode. All compressors, condenser fans and the Humidification output are deenergized for any VOM sequence. The factory default definitions for each mode are as follows:

- **UNIT OFF sequence "A"**

When complete system shutdown is required the following sequence can be used.

- Supply Fan - Off
- Supply Fan VFD - Closed/Min (if so equipped)
- Exhaust Fan - Off; Exhaust Dampers Closed (if so equipped)
- OA Dampers - Closed; Return Damper - Open

- Heat - All heat stages off; Mod Heat output at 0 VDC
- Occupied/Unoccupied/VAV box output - Deenergized
- VOM Relay - Energized
- Preheat Output - Off
- Return Fan - Off; Exhaust Dampers - Closed (if so equipped)
- Return VFD - Min (if so equipped)
- OA Bypass Dampers - Open (if so equipped)
- Exhaust Bypass Dampers - Open (if so equipped)

- **PRESSURIZE sequence "B"**

Perhaps a positively pressurized space is desired instead of a negatively pressurized space. In this case, the supply fan should be turned on with VFD at 100% speed and exhaust fan should be turned off.

- Supply Fan - On
- Supply Fan VFD - Max (if so equipped)
- Exhaust Fan - Off; Exhaust Dampers Closed (if so equipped)
- OA Dampers - Open; Return Damper - Closed
- Heat - All heat stages off; Mod Heat output at 0 VDC
- Occupied/Unoccupied/VAV box output - Energized
- VOM Relay - Energized
- Preheat Output - Off
- Return Fan - Off; Exhaust Dampers - Closed (if so equipped)
- Return VFD - Min (if so equipped)
- OA Bypass Dampers - Open (if so equipped)
- Exhaust Bypass Dampers - Open (if so equipped)

- **EXHAUST sequence "C"**

With only the exhaust fans running (supply fan off), the space that is conditioned by the rooftop would become negatively pressurized. This is desirable for clearing the area of smoke from the now-extinguished fire, possibly keeping smoke out of areas that were not damaged.

- Supply Fan - Off
- Supply Fan VFD - Closed/Min (if so equipped)
- Exhaust Fan - On; Exhaust Dampers - Open (if so equipped)
- OA Dampers - Closed; Return Damper - Open
- Heat - All heat stages off; Mod Heat output at 0 VDC
- Occupied/Unoccupied/VAV box output - Deenergized
- VOM Relay - Energized
- Preheat Output - Off
- Return Fan - On; Exhaust Dampers - Open (if so equipped)
- Return VFD - Max (if so equipped)
- OA Bypass Dampers - Open (if so equipped)



## Installation

- Exhaust Bypass Dampers - Open (if so equipped)
- **PURGE sequence “D”**

Possibly this sequence could be used for purging the air out of a building before coming out of Unoccupied mode of operation on VAV units or for the purging of smoke or stale air if required after a fire.

  - Supply Fan - On
  - Supply Fan VFD - Max (if so equipped)
  - Exhaust Fan - On; Exhaust Dampers - Open (if so equipped)
  - OA Dampers - Open; Return Damper - Closed
  - Heat - All heat stages off; Mod Heat output at 0 VDC
  - Occupied/Unoccupied/VAV box output - Energized
  - VOM Relay - Energized
  - Preheat Output - Off
  - Return Fan - On; Exhaust Dampers - Open (if so equipped)
  - Return VFD - Max (if so equipped)
  - OA Bypass Dampers - Open (if so equipped)
  - Exhaust Bypass Dampers - Open (if so equipped)
- **PURGE with duct pressure control sequence “E”**

This sequence can be used when supply air control is required for smoke control.

  - Supply Fan - On
  - Supply Fan VFD - (If so equipped) Controlled by Supply Air Pressure Control function; Supply Air Pressure High Limit disabled
  - Exhaust Fan - On; Exhaust Dampers Open (if so equipped)
  - OA Dampers - Open; Return Damper - Closed
  - Heat - All heat stages off; Mod Heat output at 0 VDC
  - Occupied/Unoccupied/VAV box output - Energized
  - VOM Relay - Energized
  - Preheat Output - Off
  - Return Fan - On; Exhaust Dampers - Open (if so equipped)
  - Return VFD - Max (if so equipped)
  - OA Bypass Dampers - Open (if so equipped)
  - Exhaust Bypass Dampers - Open (if so equipped)

### Temperature vs. Resistance Coefficient

The UCM network relies on various sensors located throughout the system to provide temperature information in the form of an analog input. All of the sensors used have the same temperature vs. resistance co-efficient and are

made from Keystone Carbon D97 material with a 1 degree Centigrade tolerance.

**Table 31. Temp vs. resistance**

Temp (°F)	Resistance (in. 1000 Ohms)	Temp (°F)	Resistance (in. 1000 Ohms)
-40	346.10	71	11.60
-30	241.70	72	11.31
-20	170.10	73	11.03
-10	121.40	74	10.76
-5	103.00	75	10.50
0	87.56	76	10.25
5	74.65	77	10.00
10	63.80	78	9.76
15	54.66	79	9.53
20	46.94	80	9.30
25	40.40	85	8.25
30	34.85	90	7.33
35	30.18	100	5.82
40	26.22	105	5.21
45	22.85	110	4.66
50	19.96	120	3.76
55	17.47	130	3.05
60	15.33	140	2.50
65	13.49	150	2.05
66	13.15	160	1.69
67	12.82	170	1.40
68	12.5	180	1.17
69	12.19	190	0.98
70	11.89	200	0.83

### Emergency Stop Input

A normally closed (N.C.) switch wired to the customer connection (1KF11) and 1XD24 may be used during emergency situations to shut down all unit operations. When opened, an immediate shutdown occurs. An emergency stop diagnostic is entered into the user interface. The unit must be manually reset. Refer to the appropriate illustrations in and for the proper connection terminals in the unit control panel. The switch must be rated for 12 ma @ 24 VDC minimum.

### Occupied/Unoccupied Contacts

To provide Night Setback control if a remote panel **with NSB** was not ordered, a field supplied contact must be installed. This binary input provides the Occupied/Unoccupied status information of the building to the Symbio 800. It can be initiated by a time clock, or a Building

---

Automation System control output. The relay's contacts must be rated for 12 ma @ 24 VDC minimum. Refer to

schematics supplied with the unit for proper connection terminals in the unit control panel.



# Unit Startup

## Sequence of Operation

### NOTICE

#### Compressor Failure!

Failure to follow instruction below could result in compressor failure.

Unit must be powered and crankcase heaters energized at least 8 hours BEFORE compressors are started.

### Stop/Off/Auto

There are a number of reasons the Symbio 800 controller will have the IntelliPak unit stopped or off. The user interface home screen displays unit mode of Stopped or Auto. Stopped is indicated when an override is preventing operation such as: Local Stop, Emergency Stop or Equipment Stop input is active. Auto is indicated when in automatic control but is currently off in modes such as: Unoccupied, Ventilation Override, Emergency Override or the like.

When Heat Cool Mode Status is Off, unit operation will be prevented; whereas, all other modes allow operation.

### Power-Up Start Delay

Anytime power is apply to the unit or the controller is reset, and the unit is able to run, a user adjustable Power-Up Start Delay setting is enforced to allow staggered starts of multiple units. The user interface home screen displays Run Inhibit when active. Power Up Delay Inhibit, with remaining minutes and seconds, will be displayed on user interface operating modes screen. Power-Up Start Delay is also applies to Rapid Restart, or when the controller exits Ventilation Override or Emergency Override modes.

### Normal Unit Starting

When Local Stop, Stop modes, overrides, and diagnostic shutdowns are removed, the controller will start unit operation. The supply fan starts and increases to the minimum Hz setting and must prove On. Unit mode Running is displayed on the user interface. The supply fan will run for one minute, with the outdoor air damper closed, before transitioning into an active heat or cool mode.

### Rapid Restart Operation

The purpose of rapid restart is to insure the space temperature recovers from high heating loads once the unit has recovered from a power outage. This is accomplished by utilizing aggressive economizing and/or compressor staging in a user adjustable amount of time. After a Rapid Restart event, the unit can subsequently manage the load using normal capacity control. A typical application is a data center.

The unit configuration must have Rapid Restart configured as "Installed" and the Rapid Restart Enable feature setting

must be set to "True" to allow this function to operate. Mechanical cooling (DX) is available for Rapid Restart if the Outdoor Air Temperature is above the Low Ambient Lockout setpoint.

After power-up start delay is satisfied, the unit will override all other forms of time delays (i.e. ICS, VAV Box Stroke Time, Outdoor Air Damper Stroke Time) and allow the Supply Fan to start. Once the Supply Fan has proven, the unit will determine the proper staging sequence by processing outdoor air temperature and return air temperature. The unit will generate a Rapid Restart mode annunciation on the user interface, operating modes screen.

VOM and Emergency Override have higher priority than Rapid Restart. If either occur, Rapid Restart will be terminated and the VOM or Emergency Override will be performed. Demand limit also has priority over Rapid Restart.

The unit will terminate Rapid Restart and will de-energize the VAV Box Relay (if installed), and release to normal unit control when the Cooling Capacity Status meets or exceeds the Rapid Restart Capacity Target or when the Rapid Restart Termination Time expires.

### Occupancy

There are many sources and types of occupancy. These have an effect on the operation of the IntelliPak unit. All sources are arbitrated (prioritized) into a final occupancy status.

#### Sources of Occupancy

- Occupancy Request is a communicated value from a Building Automation System (BAS) schedule.
- Occupancy Input is a local input from the space served by the equipment. These are typically optional local time clocks or occupancy sensors. This is a physical input to the Symbio controller and is field installed.
- Bypass Timer starts because of a user requested occupancy override (also known as Occupied Bypass). The occupant requests temporary occupied comfort heating or cooling during unoccupied scheduled time periods. An example of this would be the Timed Override (TOV) button on the zone sensor. See "Timed Override," p. 63 for more information.

### Occupancy Status Definitions

**Occupied Operation:** The IntelliPak unit is running in a Normal mode providing temperature and ventilation control to the normal occupied setpoints and comfort demands of the occupants.

**Unoccupied Operation:** The IntelliPak unit is typically shut down and is not providing temperature control to the normal occupied setpoints. No ventilation is required or provided. Temperature control is determined by energy conservation and building protection thresholds.

**Occupied Bypass Operation:** The IntelliPak unit is temporarily in an Occupied state for some period of time and will automatically return to unoccupied operation when the bypass timer expires. The Occupied Bypass Timer is a user-adjustable field. However setting the timer to 0 minutes effectively disables Timed Override at the equipment controller.

**Occupied Standby Operation:** Standby does not apply to a discharge air controller (VVDA, CVDA unit type). These units treat Standby as Occupied. Space temperature control units in an Occupied-Standby state are controlling to occupied standby temperature setpoints. Normal operation will resume when Occupancy Status goes to an Occupied state.

**Table 32. Occupancy Status**

Occupancy Request	Occupancy Input	Bypass Timer	Occupancy Status
Occupied	Occupied	Any Number	Occupied
Occupied	Unoccupied	Zero	Standby
Occupied	Unoccupied	Not Zero	Bypass
Unoccupied	Any State	Zero	Unoccupied
Unoccupied	Any State	Not Zero	Bypass
Bypass	Occupied	Any Number	Occupied
Bypass	Unoccupied	Zero	Standby
Bypass	Unoccupied	Not Zero	Bypass
Standby	Any State	Zero	Standby
Standby	Any State	Not Zero	Bypass
Auto	Occupied	Any Number	Occupied
Auto	Unoccupied	Zero	Unoccupied
Auto	Unoccupied	Not Zero	Bypass

### Timed Override

Timed Override (TOV) is a function that allows a user, located in the conditioned space, to temporarily override the IntelliPak operation from unoccupied mode to occupied mode (referred to as Occupied-Bypass). To accomplish this, Trane wired or wireless zone sensor devices are equipped with “On” and “Cancel” push buttons. Some sensors refer to the buttons as “Occupied” and “Unoccupied”. Timed override operation applies, in some way, to all unit types.

On Wired sensors, the timed override request (ON) and timed override cancel (CANCEL) buttons momentary modify the zone temperature thermistor resistance to a

value outside the normal zone temperature operating range. The Symbio 800 controller detects this change; however, this momentary button press does not disrupt the space temperature value being used for heating and cooling control. The press duration is 0.5 to 8 seconds.

Wireless sensors process the timed override request/cancel signal at the sensor and communicate the appropriate timed override status (mode).

### Service Pin Message Request

A secondary feature of wired zone sensors is Service Pin Message Request, not associated with TOV. An On/ Occupied push button press for 8 to 30 seconds can initiate Neuron ID and Program ID message broadcast on a LON network. This function is used to install and troubleshoot LON networks. This feature benefits installation of a LON device by initiating the service pin message from a zone sensor rather than at the equipment.

### Sensors

The IntelliPak unit uses many types of sensors. Most sensors are factory installed. Some sensors are field installed and may be wired or wireless. Field installed wired sensors are available from Trane and many other sources. In every case, the correct type of sensor must be used.

All sensors are factory calibrated and require no field recalibration. See the Product Catalog for more information on sensors.

### Heat Cool Mode Status

Heat Cool Mode Status reports the unit mode of operation. The Symbio 800 can receive mode inputs from different external and local input sources that are arbitrated; however, the control active operating mode represents the capacity being delivered to the building and reported via Heat Cool Mode Status.

### Heat

In this mode, the controls provide heating capacity per heat type installed, active heat setpoint, and occupancy. Application requirements such as full or modulating air flow are also considered in heating mode. All forms of cooling capacity are effectively disabled.

If Heat is the requested mode when the unit does not have heat capacity configured or heat is disabled, Heat is reported as Heat Cool Mode Status. If the unit cannot provide heat, the supply fan is enabled to operate (as configured) to provide ventilation during occupied modes of operation.

### Cool

Cool mode is reported when the control objective is to provide cooling to maintain building comfort. Direct expansion cooling is the primary cooling source. Cool mode is also reported when Economizer cooling, Dehumidification, Pre-Cool, and Night Purge sub-modes of operation are active.

For Discharge Air Control units, heat is allowed (when enabled) to temper cold mixed air conditions to the desired cooling setpoint. See Cool - Tempering sub-mode section for more information.

### Fan Only

This mode disables all forms of heating and cooling capacity but operates the fan continuously at minimum speed or modulates to maintain duct static pressure. The outdoor air damper modulates to damper minimum position setpoint or flow setpoint to provide ventilation.

Fan Only is also reported in Emergency Override and Ventilation Override Modes. Heat Cool Mode Request can also command the Fan Only mode.

### Maximum Heat

Maximum Heat is a heating mode of operation with the supply fan operating at maximum speed. The controller does not provide maximum heat (as the name infers); instead, the controller provides heat capacity per the Operating Mode and unit type.

- **Multi Zone VAV**

Multi Zone VAV control units will transition to Maximum Heat operation in heating modes (for example Occupied Heat, Morning Warm Up, Daytime Warm Up) when the installed heating capacity requires full air flow. Maximum Heat can also be a Heat Cool Mode Request command, which Symbio 800 will remain in the mode until the mode is released. On the transition to Maximum Heat the Symbio 800 will reduce the supply fan to minimum speed, energize the VAV Box Relay and wait the duration of the VAV Box Stroke Time (adjustable). The VAV Box Stroke Time allows the VAV boxes in the system to open. The supply fan speed will then increase to 100% or the maximum speed subject to high duct static pressure limit. Once the supply fan reaches its allowed maximum speed, Symbio 800 will enable heating capacity control to Discharge Air Heating Setpoint Active. Ventilation is managed per the operating mode.

The transition from Maximum Heat back to modulating air flow control modes is as follows:

1. Heat capacity terminates (if active), a 5 minute post heat timer begins.
2. Supply fan speed slows to minimum speed, a 3 minute minimum speed timer begins
3. VAV Box Relay de-energizes
4. When the 5 minute post heat and 3 minute minimum speed timer expire, modulating air

flow control is enabled, operating mode transitions, and capacity control enables.

- **Single Zone VAV (Space Temperature)**

Single Zone VAV control units will also accept a Maximum Heat command via Heat Cool Mode Request. On this command the Symbio 800 will transition to a heat mode while operating the supply fan at 100% capacity. Heat Cool Mode Status will report Maximum Heat to indicate the mode is active.

### Off

Off is the reported mode when unit operation is shutdown due to diagnostics, equipment protections or normal unit operation.

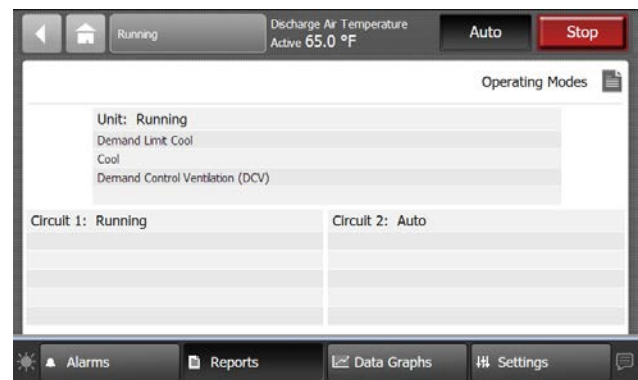
### Test

When a Manual Override is Active such that it overrides normal capacity control or limits the ability to provide comfort heating/cooling, Heat Cool Mode Status reports Test. For example, a Manual Override of a relief fan will not be reported as Test. See Programming Guide (RT-SVP011\*-EN) for more information.

## Operating Modes

The user interface Operating Modes screen provides Unit and Circuit level mode information valuable to understanding the equipment operating state. Each Unit and Circuit mode provide sub-mode information with valuable details to understand active controls and limits that are affecting operation. For more information, see Programming Guide (RT-SVP011\*-EN).

**Figure 36. Operating Modes**



### Unit

Unit modes provide a status of the equipment operating state. Each of the Unit modes will have one or more sub-modes that provide more details about the functions active in the mode.

### Stopped

Stopped is a Unit mode when control is prevented from running. For example, if External Auto/Stop binary input is active, *External Auto Stop* will be listed as a sub-mode.



### Run Inhibit

The unit is currently being inhibited from starting and running. For example, if a Power Up Delay timer is preventing the unit startup, *Power Up Delay Inhibit (Min: Sec)* will be listed with the remaining minutes and seconds to expire.

### Auto

The unit supply fan is typically running to provide ventilation. *Idle* is listed as a sub-mode on startup when the control is determining an initial heating or cooling demand. Additional sub-modes are listed when gas heat diagnostics are preventing heat operation.

### Running

Running is a Unit mode then normal heating, cooling and ventilation control functions are active. The supply fan is running. Up to four Running sub-modes will be listed on the user interface, Operating Modes screen.

### Circuit

Circuit modes provide refrigerant circuit level operating state and sub-mode information. When the unit has two circuits, the user interface will provide both Circuit 1 and Circuit 2 mode and sub-mode information.

### Stopped

The circuit is not running, and cannot run without removing a condition. For example, *Diagnostic Shutdown – Manual Reset* sub-mode is displayed when a diagnostic has caused a circuit level shutdown and a manual reset is required.

### Run Inhibit

The circuit is currently being inhibited from starting (and running), but may be allowed to start if the inhibiting or diagnostic condition is cleared. For example: *Low Ambient Temp* is displayed when outdoor air temperature is below the *Low Ambient Lockout Setpoint*; the circuit is being inhibited from starting.

### Auto

The circuit is not running but expected to start given the proper conditions are satisfied.

### Waiting to Start

The circuit is going through the necessary steps to allow the circuit to start; for example, *EXV* is being commanded to a pre-position prior to starting a compressor.

### Running

A compressor on a given circuit is currently running.

### Running — Limit

The circuit is currently running; however, the operation of the unit/compressors is actively limited by the controls. Active compressor protection sub-modes will be listed. See *Compressor Protections* section for more information.

### Shutting Down

The circuit is preparing to de-energize the compressor. For example, *Diagnostic Shutdown – Manual Reset* is

displayed when the circuit is shutting down on a latching diagnostic.

## Unit Sub-Modes

### Morning Warm Up

Morning Warm Up is an optional feature when heat is configured and can be Enabled or Disabled. Morning Warm Up is a mode often used during building unoccupied periods and optimal start applications to rapidly increase the space temperature, as efficiently as possible, before building occupancy. The outdoor air damper minimum position setpoint will be overridden to 0%, ventilation air is not provided during Morning Warm Up.

For Morning Warmup to initiate on a transition from Unoccupied to Occupied, Space temperature control units must be in Heat, Max Heat, or Auto. Discharge air control units can also initiate Morning Warm Up on an Off to Occupied transition.

For all equipment types (Constant Volume, Multi Zone-VAV, and Single Zone VAV): On a transition from Unoccupied to Occupied or Occupied-Standby, and with a valid space temperature 1.5° F below the Morning Warmup Setpoint, morning warm up operation initiates. Heat Cool Mode Status reports maximum heat if the heat type requires full airflow and VAV Box Relay binary output will energize (see *Maximum Heat* for details). Otherwise, heat types that allow modulating airflow will report heat.

The Symbio 800 operates in a discharge air control mode delivering heating capacity per Discharge Air Heating Setpoint Active; this provides flexibility when 100% heat capacity is not desired. The supply fan operates at max speed on Constant Volume Units. Variable air volume discharge air control units will operate the supply fan per Duct Static Pressure Setpoint, if the installed heat type allows. (See *Heat Types* section for more information).

When 60 minutes expires or when space temperature equals or exceeds the Morning Warmup Setpoint, Morning Warm Up mode will terminate.

Morning Warm Up mode can also be commanded via Heat Cool Mode Request from a building automation system or external control. In this case, the unit remains in Morning Warm Up mode indefinitely until the commanded mode is removed or changed. When the space temperature exceeds the Morning Warmup Setpoint, heating capacity is disabled but the supply fan operation continues to circulate air until the Morning Warm Up command is removed. Heat capacity will re-enable if space temperature falls 1.5°F below Morning Warmup Setpoint.

### Pre Cool

Pre Cool is a feature of the unit and can be Enabled, or Disabled. Pre Cool is a mode often used during building unoccupied periods and optimal start applications to rapidly decrease the space temperature, as efficiently as possible, before building occupancy. Ventilation air is not provided during Pre Cool.



## Unit Startup

Space temperature control units must be in Cool or Auto mode to allow Pre Cool operation. Discharge air control units also evaluate Pre Cool operation on transition from Off/Shutdown to Occupied.

All equipment types, a transition from Unoccupied to Occupied mode, if a valid space temperature input is above the Pre Cool Setpoint + 1.5°F, Pre Cool Mode will initiate. Symbio 800 operates in a discharge air control mode providing discharge air per Discharge Air Cooling Setpoint Active until space temperature drops equal or below the Pre Cool Setpoint. In this cooling mode the outdoor air damper minimum position is 0%, but the controller will use compressor and/or economizer cooling when suitable.

Multi Zone-VAV units will modulate fan speed and manage to the duct static pressure setpoint. All other unit types, the supply fan will operate at max speed.

Pre Cool mode can also be commanded via Heat Cool Mode Request. In this case, the Symbio 800 remains in Pre Cool indefinitely until the commanded mode is removed. When space temperature is equal or less than Pre Cool Setpoint, cooling capacity is disabled but the supply fan continues to circulate air until the Pre Cool command is removed. Cooling capacity control will enable if space temperature rises above Pre Cool Setpoint + 1.5°F.

### Night Purge

Night Purge mode is typically applied in building unoccupied periods when conditions are suitable for economizer cooling; all other forms of cooling capacity are disabled. This mode is only supported via a commanded Heat Cool Mode Request. The controller will not use local inputs and assume outdoor air is suitable for economizing. The outdoor air damper minimum position setpoint will be overridden to 0%.

When active, the Symbio 800 operates in a discharge air control mode, modulating the outdoor air damper to provide cooling capacity per Discharge Air Cooling Setpoint Active. Night Purge operation is terminated when the Night Purge, Heat Cool Mode Request is removed.

### Daytime Warm Up

Daytime Warm Up is a feature of Constant Volume and Multi Zone-VAV Discharge Air Temperature units that can be Enabled, or Disabled. Daytime Warm Up is available with any heat type installed. Daytime Warm Up is a mode used during building occupied periods to recover a critical zone that is too cold. Ventilation air is provided while in Daytime Warm Up mode.

When the Heat Cool Mode Status is Cool (the unit is providing cooling), if a valid space temperature is 3°F below the adjustable Daytime Warmup Setpoint, daytime warm up operation initiates. The unit will operate in a discharge air control mode delivering heating capacity per Discharge Air Heating Setpoint Active. The supply fan operates at max speed on Constant Volume Units. Variable air volume discharge air control units will operate the supply fan to the duct static pressure setpoint and report Heat Cool Mode Status as Heat, if the installed heat

type allows modulating air flow. Else if the heat type requires full air flow, Maximum Heat is reported.

When the space temperature rises above the Daytime Warmup Setpoint, daytime warm up operation terminates and the Symbio 800 will transition back to Cool mode. See Maximum Heat for details. If the requested operating mode is no longer Cool, Daytime Warm Up terminates.

### Idle

Idle is a sub-mode of Space Temperature Control units configured for supply fan cycling. When there is no demand for heating or cooling the supply fan will cycle off and Idle will be displayed.

**Table 33. Summary of heat cool modes and sub modes**

Heat Cool Modes	Sub Modes
Heat	Morning Warm Up
Maximum Heat	Morning Warm <sup>(a)</sup> Daytime Warm Up
Cool	Cool – Dehumidification Cool – Economizing Cool – Economizing + DX Cool – Tempering Daytime Warm Up <sup>(a)</sup> Pre Cool Night Purge
All modes	Idle Demand Limit Ventilation Override Mode X Emergency Override Mode X External Supply Fan Control External Relief Fan Control Demand Control Ventilation

<sup>(a)</sup> MZ-VAV Discharge air temperature units only

### Supply Fan Control

All IntelliPak units with the Symbio 800 controller have one or more supply fans installed with VFD drives. All fans are controlled identically. The fans are sent the On/Off command at the same time and commanded to the same speed at all times. It is assumed that the VFDs for each fan are setup identically. Supply fan operation will be confirmed via a method of proving airflow which is explained below.

### Supply Fan Speed Control

The controller sends a speed command to each VFD as a value from 0-100%. The VFD interprets the commands as 0% = Minimum frequency and 100% = Maximum frequency. See Programming Guide, Manual Overrides for more details.

The supply fan speed requested and commanded value will remain at 0% any time the Active Supply Fan Run Command = OFF. Once the Active Supply Fan Run Command = ON and the unit has transitioned into an active Heat/Cool state, the supply fan speed will be controlled as required by unit type.

- Constant Volume units always run the fans at 100% after being proved On. The command is 0% while waiting on proving.
- Multi Zone VAV units modulate the supply fan speed to perform Duct Static Pressure Control after being proved On. During full airflow modes, Adaptive High Duct Static Limit will control supply fan speed to 100% or as high as possible subject to duct static pressure high limit constraints.
- Zone Temperature units can be configured via Supply Fan Configuration Command to cycle the supply fan off when heating or cooling capacity is inactive. A demand for heat or cooling will automatically initiate supply fan operation.
- Single Zone VAV units modulate the supply fan based on capacity control after being proved On.

### Supply Fan Proving Operation and Method

Supply Fan Proving is active only after the Supply Fan Run Command is set to ON. Once set to ON, the supply fan is required to prove greater than 90% of minimum fan RPM (VFD minimum Hz setting), within 40 seconds. Fan proving fails anytime the fan is less than 90% of minimum RPM. A diagnostic is generated and operation stops.

**Note:** *Bypass Mode uses an alternate method of fan proving. See below for more details.*

### Supply Fan VFD Bypass Control

All units will have a configurable option to provide Supply Fan VFD Bypass control. Whenever the bypass option is installed, the unit will include all of the necessary components to bypass the VFD assembly and allow the supply fan to operate at line frequency.

### Entering VFD Bypass Control

- The supply fan must be off and no-discharge air flow (duct static pressure) detected for 40 continuous seconds to enter or leave Supply Fan VFD Bypass Mode.
- Enabling and disabling Supply Fan VFD Bypass Mode can only take place from the unit user interface.
- Both supply fan VFDs will be bypassed and the fans then operate at line frequency.
- During active Supply Fan VFD Bypass Mode
  - The Modbus communicated command for supply fan will be set to OFF, and the communicated speed command will be set to 0%.
  - All supply fan VFD diagnostics will be masked.
  - A warning only, latching “Supply Fan Bypass Enabled” diagnostic will be generated.
  - A duct static pressure sensor, if installed, will be used to perform Duct Static Pressure High Limit protection if enabled for bypass operation.

See Programming Guide (RT-SVP011\*-EN) for more information.

### Exiting Supply Fan VFD Bypass Mode

- The user will not be allowed to remove the unit from an active *Supply Fan VFD Bypass Mode* at the user interface until all of the following has occurred:
  - The user has requested *Unit Stop Mode* from the user interface.
  - All components have been commanded OFF or CLOSED.
  - The fan proving mechanism indicates a supply fan no-flow condition has existed for 40 continuous seconds.
- When the user removes the unit from active Supply Fan VFD Bypass Mode at the user interface, all of the following will be enforced:
  - The *Supply Fan Bypass Relay* will remain OFF.
  - The *VAV Box Relay* will be commanded OFF (de-energized) to indicate normal airflow mode to the system, and the *VAV Box Stroke Time* will count down.
  - Once the above conditions have been satisfied, the user will be allowed to request *Unit Auto Mode* at the user interface.
- At all times when the unit is not in an active *Supply Fan VFD Bypass Mode*, the *Supply Fan Bypass Relay* will be commanded OFF (de-energized).

### Supply Fan Proving with VFD Bypass

Units configured with Supply Fan VFD Bypass option require two modes of supply fan proving. During non-Bypass unit operation supply fan proving will use the fan’s VFD RPM as is used normally. The enabling and disabling of Supply Fan Bypass Mode, as well as unit operation during an active bypass event, requires Duct Static Pressure to be used for supply fan proving.

**Note:** *The enabling and disabling of VFD Bypass will be dis-allowed until the Duct Static Pressure indicates no flow per the below option.*

Proving criteria for proof of flow: When Duct Static Pressure rises above the Bypass Duct Static Diff Pressure setting, the supply fan will indicate a Flow condition.

Proving criteria for proof of no flow: If this pressure remains below 30% of the Bypass Duct Static Diff Pressure setting for 40 continuous seconds, the supply fan will indicate a No-Flow condition.

### Operation during Manual Override and VOM (Emergency Override) Modes

Manual Override, VOM, and Emergency Override modes will operate as defined except for the following modifications:

1. If the fan is ON it will run at line frequency.
2. The VAV Box Relay will follow the defined operation specified in each VOM Mode user interface setting.



## Unit Startup

- External fan control in bypass mode is supported. An external Supply Fan Speed Setpoint value = 0% will turn the fan Off, and any value > 0 will turn the fan On. The Supply Fan Speed Status always reports 100% speed during active supply fan bypass operation.

### Minimum Ventilation Control

Symbio 800 provides outdoor air minimum ventilation control via options described below. Traq™ outdoor air flow control is the highest priority when installed and enabled. If Traq becomes disabled or inactive, Outdoor Air Flow Compensation will calculate a damper minimum position setpoint (this option should be disabled on constant volume units). If Outdoor Air Flow Compensation is disabled, Outdoor Air Minimum Position Setpoint will calculate damper minimum position setpoint.

### Outdoor Air Flow Control (Traq)

The outdoor air damper is modulated to provide outdoor air flow (cfm) required by Outdoor Air Minimum Flow Setpoint. The outdoor air damper will modulate closed and open to maintain the required outdoor air minimum flow rate. See [Table 34, p. 68](#) for additional information and settings.

The provided air flow measurement capabilities include periodic, automatic calibration; however, air flow gain and offset settings are provided for field adjustment.

### Outdoor Air Flow Compensation

The outdoor air damper minimum position is modulated to provide outdoor air based on a variable supply fan speed. When supply fan increases speed the outdoor air damper minimum position is reduced, to prevent over ventilation. When supply fan decreases speed the outdoor air damper minimum position is increased to maintain design outdoor air flow requirements. There are three user editable

settings to linearize damper position with the fan curve. See [Table 34, p. 68](#) for additional information.

### Outdoor Air Minimum Position Control

This function provides a fixed damper position for minimum outdoor airflow requirements. The damper is controlled to a position determined by Economizer Minimum Position Setpoint Active. This feature is available on all unit types with an outdoor air damper, but commonly used on constant volume units.

### Demand Control Ventilation (DCV)

Demand control ventilation reduces energy consumption by reducing the outdoor air damper below minimum ventilation based on space CO<sub>2</sub>. Decreasing CO<sub>2</sub> levels will decrease damper position to DCV minimum damper position setpoint. Increasing CO<sub>2</sub> level will increase damper position to design minimum setpoint. DCV requires a valid space CO<sub>2</sub> value.

Demand control ventilation setpoints used in all methods.

- Space CO<sub>2</sub> high limit
- Space CO<sub>2</sub> low limit

DCV when enabled with outdoor airflow control (Traq), DCV resets the outdoor air minimum flow setpoint based on space CO<sub>2</sub>. DCV enabled with Outdoor Air Flow Compensation, DCV resets the outdoor air damper minimum position based space CO<sub>2</sub> and supply fan speed. DCV enabled with Outdoor Air Minimum Position Control resets the outdoor air damper minimum position based on space CO<sub>2</sub>.

Table below summarizes the settings used for each Minimum Damper Position Control and Demand Control Ventilation.

**Table 34. Outdoor air damper minimum ventilation control methods**

Traq	Outdoor Air Flow Compensation	Demand Control Ventilation	Description	Outdoor Air Damper Controlling Setpoints
Enabled/Active	Disabled	Disabled	Damper controls to outdoor air minimum flow setpoint	Setpoint: Outdoor Air Minimum Flow Setpoint Active Outdoor Air Minimum Flow Setpoint Status
Enabled/Active	Disabled	Enabled/Active	Outdoor Air Flow setpoint is reset based on space CO <sub>2</sub> .	Setpoint: Outdoor Air Minimum Flow Setpoint Status  Settings: Design Min Outdoor Air Flow Setpoint DCV Min Outdoor Air Flow Setpoint

**Table 34. Outdoor air damper minimum ventilation control methods (continued)**

Traq	Outdoor Air Flow Compensation	Demand Control Ventilation	Description	Outdoor Air Damper Controlling Setpoints
Disabled	Enabled/Active	Disabled	Outdoor Air Damper Minimum Position is reset based on supply fan speed.	Setpoint: Economizer Minimum Position Setpoint Active  Settings: Design Min OA Damper Pos Setpoint Max Fan Design Min OA Damper Pos Setpoint Mid Fan Design Min OA Damper Pos Setpoint Min Fan
Disabled	Enabled/Active	Enabled/Active	Outdoor Air Damper Minimum Position is reset based on supply fan speed and space CO <sub>2</sub> .	Setpoint: Economizer Minimum Position Setpoint Active  Settings: Design Min OA Damper Pos Setpoint Max Fan Design Min OA Damper Pos Setpoint Mid Fan Design Min OA Damper Pos Setpoint Min Fan DCV Min Outdoor Air Dampr Pos at Max Fan DCV Min Outdoor Air Dampr Pos at Min Fan
Disabled	Disabled	Enabled/Active	Outdoor Air Damper Minimum Position is reset based on space CO <sub>2</sub> .	Setpoint: Economizer Minimum Position Setpoint Active  Settings: Design Min OA Damper Position DCV Min Outdoor Air Damper Pos Setpoint
Disabled	Disabled	Disabled	Outdoor air damper position is controlled by cooling	Setpoint: Economizer Minimum Position Setpoint Active

During normal occupied periods of heating and cooling modes of operation, the outdoor air damper maintains ventilation requirements via the minimum position control methods. However, the following modes of operation will override the damper minimum position setpoint to 0%.

- Morning Warm Up
- Pre cool
- Night Purge
- Unoccupied Heat
- Unoccupied Cool
- Off

### Relief Fan and Space Static Pressure Control

The primary role of relief fan is to relieve air from the building to control space static pressure. This is common when the unit is economizing and bringing in large quantities of outside air.

### Space Static Pressure Control with Statitrac™

Statitrac™ is an option. Space static pressure control operation will become active when the supply fan is On and proven, the outdoor air damper position is greater than the relief enable position setpoint and a valid space static pressure value is greater than the active space static pressure setpoint plus half the deadband.

When the activation conditions have been met, the unit will start the relief fan and control relief damper and fan speed to maintain the space static pressure setpoint. Once the relief fan operation is proven, the fan will modulate to track the relief damper position.

Space pressure control operation terminates when the relief damper is closed and the space static pressure is below setpoint minus half the deadband, or space static pressure is within deadband for 30 minutes.



### Space Static Pressure Control without Statitrac™

If Statitrac™ is not installed, or the space static pressure sensor has failed, space static pressure control without Statitrac™ becomes active. The relief damper will track to the outdoor air damper position and the relief fan speed will track to the relief damper position when the supply fan is proven On and the outdoor air damper position is greater than the relief enable position setpoint.

Space static pressure control operation will be terminated whenever any of the activation conditions are not true, when the outdoor air damper is fully closed or when the outdoor air damper is less than the relief enable point minus 10%.

If the relief fan or damper is in failure, the relief fan will be commanded Off and the relief damper will be commanded Closed.

### 0-25% Motorized Outdoor Air Damper

The outdoor air damper will drive open to a position between 0 and 25% position set from the user interface when the supply fan turns on during occupied periods. It is driven closed when the fan is turned off or during unoccupied periods. The following options and functions are disallowed with 0-25% Motorized Outside Air Damper:

- Economizing
- Fresh Air Measurement
- OA CFM Compensation (VAV units)
- Relief fan
- Space Pressure Control
- Supply Air Low Limit
- Return Fan
- Energy Recovery
- Demand Controlled Ventilation
- Ultra-Low Leak Damper Option

### Units Without a Return Air Damper

For units without a Return Air Damper, special consideration of the outdoor air damper is required. The only airpath for supply fan operation will be provided via the outdoor air damper. If this damper fails, the supply fan operation must be terminated immediately. Additionally, to support proper airflow, the outside air damper must be opened prior to the supply fan being allowed to start. The following options and functions are disallowed when units are configured without a Return Air Damper:

- DCV
- TRAQs
- Economization
- OA Compensation

- Ventilation Override Mode
- Emergency Override
- External Capacity Control
- Return/Relief fans with and without bypass
- Statitrac
- Ultra-low Leak dampers
- Energy Recovery Wheel
- Rapid Restart

### Units With Independent Return Air Damper Control

All units complying with agency (Title 24) requirements and/or units configured with energy recovery option, need independent control of the return air damper relative to the normal outdoor air damper mechanical linkage arrangement of other units. This requires a dedicated actuator and control scheme. The behavior of this configuration utilize the same 0-100% command to the outdoor air damper mapping it also to the return air damper actuator. For the outdoor air damper 0% equates to fully closed and 100% is fully opened. To satisfy this one command control for both dampers, the 0% command for the return damper equates to fully open and 100% command equates to fully closed.

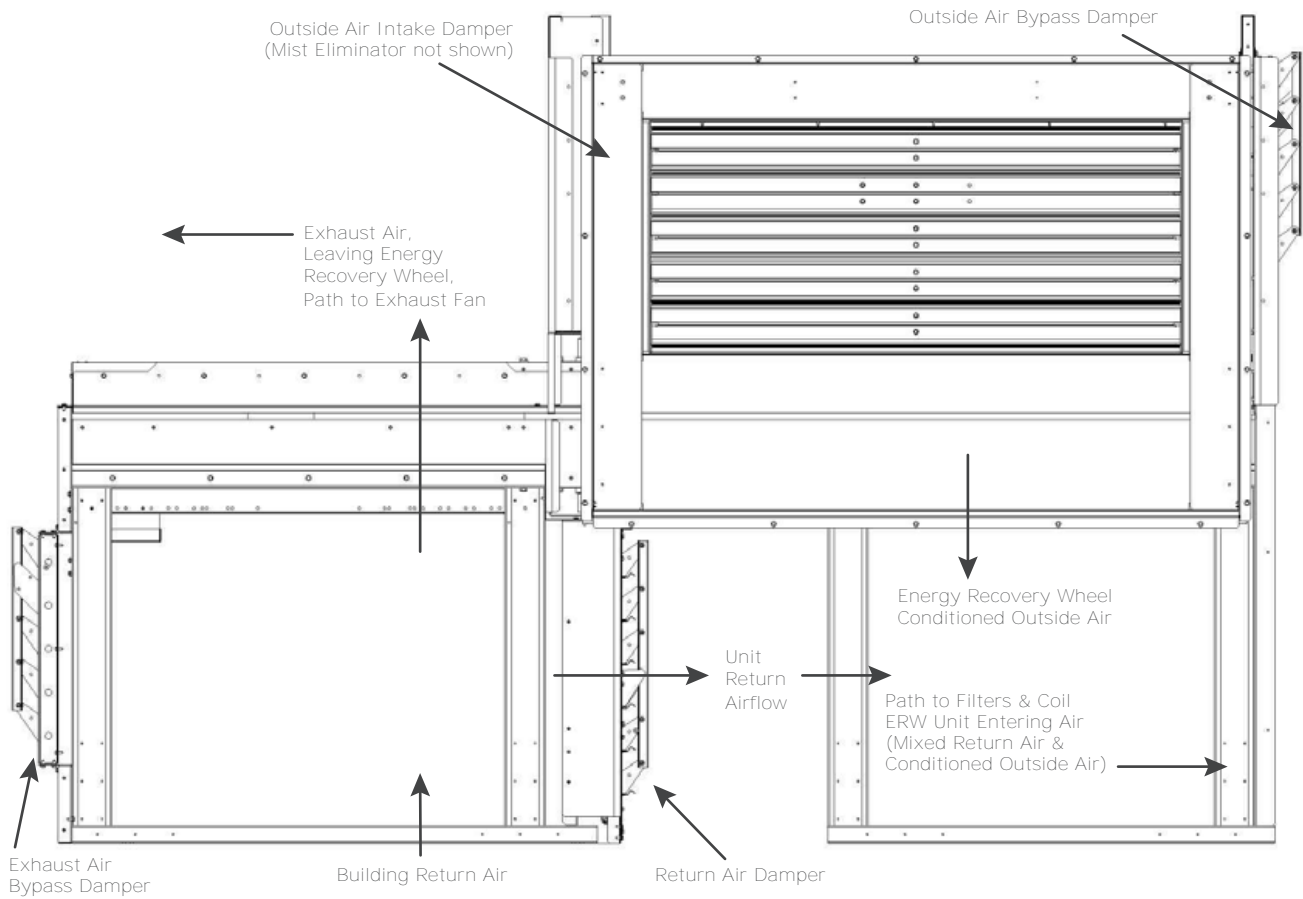
### Energy Recovery Wheel

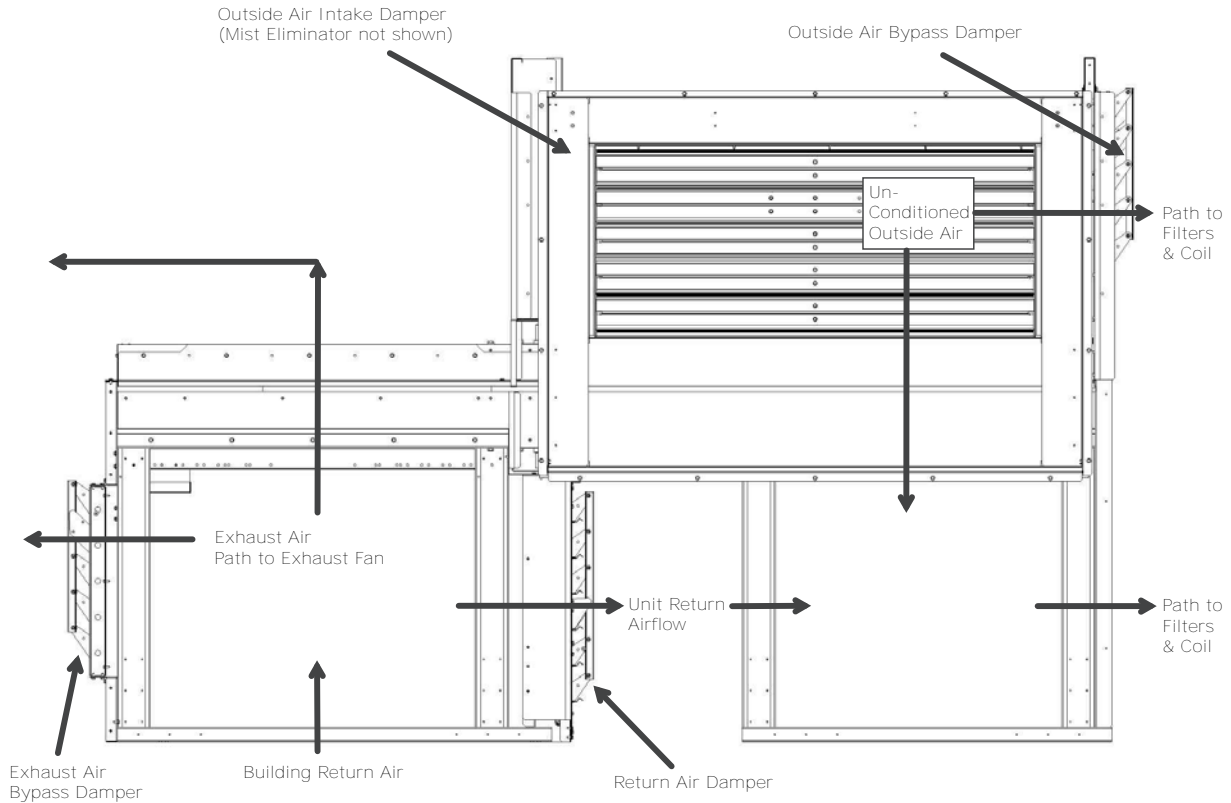
The primary components of the energy recovery system are the energy recovery wheel, relief air bypass damper, outdoor air bypass damper, and the energy recovery preheat output. See [“Energy Recovery Wheel,” p. 70 and Figure 38, p. 72](#)

Filter and differential pressure sensors are also placed between the wheel and the outdoor air damper. An adjustable setpoint is provided at the user interface. When the measured pressure exceeds this setpoint a diagnostic will be generated to notify the user when that filter needs to be changed. The differential pressure is only valid when the outdoor air bypass damper is fully closed.

When the energy recovery wheel is not operational, including when the unit is powered off, both bypass dampers are driven open. Both dampers actuate from a command of 0% to 100% where 0% equates to fully open (minimum capacity) and 100% equating to fully closed (maximum capacity). The energy recovery wheel is only energized when both the Supply Fan and Relief Fan are requested on by the various functions that control them. Energy recovery is a passive function and does not request fan operation. Once the required airflow is present, the wheel is commanded on if the indoor vs. outdoor conditions are such that energy can be recovered. This is assessed differently in cooling and heating modes.

**Figure 37. Energy recovery wheel operation**



**Figure 38. Energy recovery wheel economizer operation**


### Energy Recovery Wheel Availability

In cooling mode, wheel activation conditions are assessed based on indoor (return air) vs. outdoor enthalpy. Indoor and outdoor enthalpy values are calculated using the same sensors as used for comparative enthalpy. If the outdoor enthalpy is 3 BTU/pound greater than indoor enthalpy, the wheel is activated to remove energy from the incoming outdoor air. Any time economizing operation is active energy wheel operation is inhibited.

In heating mode, the wheel is activated based on indoor (return air) vs. outdoor dry bulb temperature. If the outdoor air temperature is 5° F less than the indoor (return) air temperature the wheel is activated to recover heat energy from the relief air.

### Energy Recovery Cooling

During active energy recovery cooling modes, both bypass dampers are driven closed to provide 100% energy recovery cooling. VAV units only consider the enthalpy evaluation to enable active cooling. Single Zone units not only consider the enthalpy evaluation, but also check if the Space Temperature has exceeded the Space Temp

Cooling Setpoint. If the temperature fall below this setpoint, active energy recovery wheel operation for cooling is terminated.

### Energy Recovery Heating

Energy recovery heating is available for occupied heating modes VAV, Single Zone, Daytime Warmup, and SA Tempering. Both VAV and Daytime Warmup modulate the bypass dampers closed in sequence, Outdoor Air Bypass first then Return Air Bypass, to provide capacity control of discharge air temperature to the Active Heating Setpoint. SA Tempering controls the dampers the same way to maintain discharge air temperature to the SA Cooling Setpoint. Single Zone units also consider the Space Temperature relative to the Space Heating Setpoint for active recovery wheel heating, enabling the wheel when the temperature is less than the setpoint and disabling the wheel when the temperature exceeds the setpoint.

### Energy Wheel Frost Avoidance

During active heating modes, the control will attempt to prevent frost forming on the wheel as the Leaving



Recovery Temperature Sensor value falls below the Recovery Frost Avoidance Setpoint. The Leaving Recovery Temperature Sensor is installed in the leaving air stream on the relief-fan side of the energy wheel. This is accomplished by opening the Outdoor Air Bypass Damper removing cold airflow through the wheel while heating continues with the Relief Air Bypass Damper which remains in control.

### Energy Wheel Frost Avoidance w/ Preheat (Optional)

During active frost avoidance, the preheater function, if installed, is used to provide additional heat to reduce wheel frost conditions by energizing the energy recovery preheat output. Because preheat control is third-party provided, it can be a significant source of heat and the control will coordinate the operation of preheat and primary heat. If primary heat is not active whenever preheat is turned on, the primary heat capacity control is delayed allowing preheat to maximize its capacity. Once the Outdoor Air Bypass Damper has fully opened and additional heat is required, primary heat sources are allowed.

### Energy Wheel Proving Status

Wheel proving uses temperature sensors to validate the expected operating condition provided by an active wheel. A wheel that is not active (failed motor, broken belt, etc..) will not reflect temperature values that normally would be expected.

When the wheel is off, Wheel Proving Status is set to "false". When the wheel is turned on, Wheel Proving Status is initialized to "true" and Wheel Proving update is pending. There are three temperature sensors monitored to update Wheel Proving Status: Energy Wheel Leaving Air Temperature (Tlw), Return Air Temperature (Tra) and Outdoor Air Temperature (Toa).

When the energy wheel is started, a five-minute ignore time is applied to Wheel Proving Status update, no proving calculations are made, and Wheel Proving Status remains "true". After this initial ignore time expires, wheel proving validity and Wheel Proving Status are evaluated continuously and a five-minute validity timer is started:

If the temperature difference between Toa and Tra is greater than or equal to 13F wheel proving validity is valid.

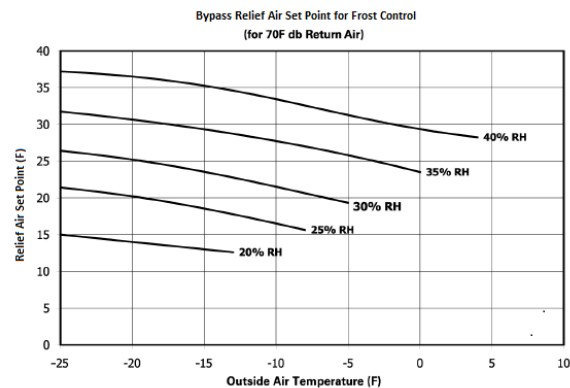
When the temperature difference is less than 13F wheel proving validity is invalid.

If the temperature difference between Tlw and Tra is greater than or equal to 3F, or the wheel proving validity is invalid, the validity timer is reset to five minutes and Wheel Proving Status is set to "true". If the temperature difference is less than 3F and wheel proving validity is valid, the validity timer begins to count down. If the validity timer times-out (after five continuous minutes), the Energy Wheel Proving Status is set to "false" and the Energy Wheel Proving Failure diagnostic is generated.

The Leaving Recovery Temp Sensor is installed in the leaving air stream on the relief-fan side of the energy wheel.

The figure below provides the relief air temperature setpoint for 70°F return air at various precents of relative humidity.

**Figure 39. Energy recovery wheel relief air setpoint temperatures**



### Return Fan

The return fan operates to assist the supply fan to overcome duct system static pressure. The variable speed return fan operates in coordination with the supply fan operation, outdoor air damper, and relief damper to maintain a proper return plenum static pressure. Return plenum static pressure minimum and maximum setpoints are adjustable by the user. The controller calculates a suitable Return Plenum Static Pressure Target within the minimum and maximum setpoints based on status of the relief damper, outdoor air damper, and supply fan. The Return Plenum Static Pressure Target setpoint increases with increasing outdoor air and relief damper positions. However, the return fan speed will be limited or reduced if return plenum pressure approaches the Return Plenum Static Pressure High Limit.

### Return Fan Control with Statitrac (Space Static Pressure Control)

Return Fan Control with Statitrac (Space Static Pressure Control) When Space Static Pressure Control (Statitrac) is configured, return fan operation assists to prevent too low or high space static pressure conditions. The return fan control reduces return fan speed under adaptive control in response to critically low space static pressure.

The return fan control increases fan speed above the plenum static pressure setpoint target in response to high space static pressure. This feature, Return Fan Minimum Capacity Limit Enable, can be disabled from Tracer TU or the touchscreen display.

### Return Fan Startup

Return fan startup is coordinated with supply fan and return plenum pressure sensor proving. Return fan releases to



## Unit Startup

---

“in-control” when supply fan and return fan are proven. Supply fan operation always starts before return fan.

### Return Plenum Pressure Sensor Proving

The return plenum static pressure sensor is proven in the return fan startup sequence. An initial return plenum static pressure sensor value is recorded, and then supply fan starts and holds at the configured minimum fan speed. The return plenum static pressure sensor is proven by a +/-0.03 IWC delta within 1 minute. Once supply fan and return plenum static pressure sensor are proven, the return fan starts and operation proven before releasing to return fan speed control. If the return plenum pressure sensor is not proven within one minute of supply fan starting, the return fan operation starts, and an additional two-minute timer is initiated. The return plenum static pressure sensor must demonstrate a +/-0.03 IWC delta within the two minutes. Otherwise, a Return Plenum Static Pressure Sensor diagnostic is generated.

### Return Fan Control

When return fan is released to algorithm control, an initial return plenum static pressure setpoint is calculated based on the relief damper status. If the relief damper is closed (0%), the setpoint is -0.05 IWC, otherwise a calculated target is determined. From this initialization the control calculates a soft-load target setpoint.

As increasingly greater supply fan and outdoor air is delivered to the space, the relief damper will open to relief air the space under normal conditions. The greater air volume being supplied and relieved will increase the target return plenum static pressure target. The return plenum static pressure target setpoint is managed between Return Plenum Static Pressure Minimum Setpoint and Return Plenum Static Pressure Maximum Setpoint.

### Return Fan Control Limits

The following limits apply to return fan control and are only active when the return fan is “in-control”. The limits are described lowest to highest priority order:

1. Return Fan Minimum Capacity Limit (Statitrac control active)
2. Return Plenum Static Pressure High Limit
3. Return Fan Critical Low Space Pressure Limit (Statitrac control active)

### Return Fan Minimum Capacity Limit

Return Fan Minimum Capacity Limit permits the return plenum static pressure to increase above the Return Plenum Static Pressure Control Target setpoint and Return Plenum Static Pressure Maximum Setpoint to ensure there is sufficient return plenum pressure for proper space static pressure control.

### Return Plenum Static Pressure High Limit

If return plenum static pressure approaches the Return Plenum Static Pressure High Limit, the return fan speed is

limited by Return Plenum Static Pressure High Limit control to prevent potential equipment cabinet damage.

### Return Fan Space Pressure Critical Low Limit

Return fan space pressure critical low limit applies when Statitrac (space static pressure control) is active. Normally return fan speed is controlled to maintain the Return Plenum Static Pressure Target. If a critically low space static pressure occurs, the relief damper control and return fan speed control is utilized in sequence to allow space static pressure recovery. When space static pressure approaches Space Static Pressure Low Limit Setpoint, Relief Damper Space Static Pressure Low Limit incrementally closes the relief damper. When the relief damper command is 0%, Return Fan Space Static Pressure Critical Low Limit incrementally reduces the return fan to minimum speed.

### Discharge Air Temperature Control

Discharge Air Temperature Control uses available heating and cooling capacity to deliver the required temperature at the discharge of the unit. A discharge air temperature sensor is required for operation.

In cooling modes, the control uses cooling sources to deliver air temperature as required by the Discharge Air Cooling Setpoint. In heating modes, the control uses heat sources to deliver air temperature as required by the Discharge Air Heating Setpoint. Primary heat is never used in conjunction with mechanical cooling.

### Multi Zone-VAV - Discharge Temperature Units

These unit types provide Discharge Air Temperature Control in all heat, cool, and occupancy modes of operation. The typical operating mode is Cooling delivering conditioned air to multiple zones of a building. Multi Zone-VAV units have duct work to supply VAV terminal units. The VAV units modulate to control space comfort.

These units also change over to provide heat (when installed). A building automation system or VAV Box Relay Output can be used when the heat source requires full airflow. See Heat Types for more information. A valid space temperature input must be provided to perform heating modes such as Daytime Warm Up and Morning Warm Up (when enabled).

### Supply Air Tempering

Supply Air Tempering is a function of discharge air control Cool mode when DX cooling is off and the outdoor air damper is at minimum position. This function is typically required when outdoor air intake percentage is high and the outdoor air temperature is low. If discharge air temperature falls below the Discharge Air Cooling Setpoint, the control will temper (warm up) the discharge air by initiating heating capacity. Cool – Tempering is displayed on the user interface Operating Mode screen when this function is active. The control will transition back to normal

cooling when heat capacity is no longer required. Supply Air Tempering is disabled by default.

Multi Zone-VAV equipment allows supply air tempering when equipped with Modulating Gas, Ultra Modulating Gas, and SCR Electric Heat. Constant Volume – Discharge Air Temperature equipment allow all forms of heating to provide supply air tempering.

### Changeover Input

Multi Zone-VAV and Constant Volume Discharge Temperature units configured with heat include a binary Changeover Input. An open input requests discharge air cooling operation. A closed input will change over to discharge air heating. This local input is arbitrated with building management Heat Cool Mode Request commands to determine the active mode of operation.

### VAV Box Relay Output

This binary output is provided by the controller to be optionally wired to VAV units in a Multi Zone-VAV system to coordinate system changeover to full airflow heating. The binary output is de-energized when the controller is operating in cooling modes. The binary output energizes when the heat type installed requires full airflow. See Maximum Heat for more details.

### Discharge Air Reset

Discharge Air Reset is a method to save energy by resetting the discharge air temperature as heating and cooling building loads increase and decrease.

When enabled, the controller can independently reset the Discharge Air Heating Setpoint Active and/or Discharge Air Cooling Setpoint Active based on Zone (space temperature) or Outdoor Air temperature. The new target setpoints are reported as Discharge Air Setpoint Heating Status and Discharge Air Cooling Setpoint Status.

The user interface display provides settings for the reset temperature range (Zone or Outdoor Air) and discharge air temperature setpoint reset amount over the specified range. For example: the discharge air temperature cooling setpoint shall increase 5°F over an outdoor air temperature range of 90°F to 70°F. If Discharge Air Cooling Setpoint Active is 50°F and Outdoor Air Temperature is 80°F, the reset function calculates and reports Discharge Air Cooling Setpoint Status = 52.5°F. The controller will provide discharge air at 52.5°F.

### Duct Static Pressure Control

Multi Zone-VAV equipment have variable speed supply fans and are often used in Variable Air Volume (VAV) systems consisting of ductwork serving multiple building zones and VAV boxes that control space comfort independent of the rooftop air handler. VAV boxes modulate air volume by a damper that opens and closes to maintain space comfort. In response, duct static pressure increases and decreases. The controller will modulate supply fan speed to maintain Duct Static Pressure relative to the Duct Static Pressure Setpoint

### Duct Static Pressure High Limit

The controller operates the supply fan to maintain duct static pressure below the Duct Static Pressure High Limit setpoint. In the event that duct static pressure approaches the high limit setpoint, the controller will reduce and limit the supply fan speed.

### Space Temperature Control

Space Temperature Control uses available heating and cooling to deliver comfort to a building space. The control requires a valid space temperature and discharge air sensor value; if either input to the control is invalid, the equipment cannot operate.

Space Temperature Control determines the type of load (heating or cooling) in the space based on active cooling and heating setpoints and space temperature. If space temperature is above the cooling setpoint, this represents a space-cooling load. The control will calculate a Discharge Air Temperature Setpoint to satisfy the cooling demand of the space.

The relationship of the calculated discharge air setpoint and discharge air temperature will drive heating and cooling capacity available to satisfy the discharge air temperature setpoint. For Example: As space temperature cooling load increases, space temperature control will calculate a lower Discharge Air Temperature setpoint and therefore will increase cooling capacity. The calculated discharge air cooling setpoint is bound by Discharge Air Temperature Maximum Cool Limit and Discharge Air Temperature Minimum Cool Limit.

If heat-cool mode input is either not provided or unsupported the mode input is Auto. The controller will automatically determine the appropriate heat or cool mode of operation based on space temperature, setpoints, and heating/cooling configured for the unit. Heat or Cool is reported by Heat Cool Mode Status.

### Auto Changeover

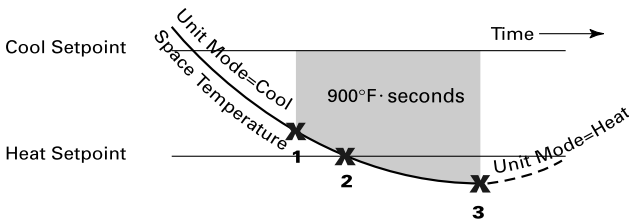
When the controller input mode of operation is Auto, the controller will automatically determine space heating and cooling mode, the unit changes from cool to heat or from heat to cool, when the integrated error between the space setpoint and space temperature is 900°F-seconds or greater. The integrated error is calculated once every 10 seconds. See figure below for an example of changing from space cooling to space heating. If Cool is the active mode and space temperature is less than 1°F below the active heating setpoint the system will immediately change to Heat mode. If space temperature is greater than 1°F above the active cooling setpoint, the mode to change to Cool.

Space Dehumidification is a Cool mode sequence of operation if the unit is equipped with hot gas reheat. A unit that has a dehumidification demand will switch from Heat mode to Cool mode if heating capacity is off and space temperature is above the heating setpoint. A unit operating in dehumidification control will inhibit the normal mode transition from Cool mode to Heat mode.



## Unit Startup

**Figure 40. Auto changeover logic**



1. This is the point at which the cooling capacity equals 0% and the error integrator starts to add up. Error integration does not begin until the capacity is 0%. The error integrator cannot be less than zero.
2. The Space Temperature must be less than Space Setpoint before the controller can change to Heat. The

Space Temperature must rise above the active space Cool Setpoint before the controller can change to Cool.

3. The controller switches to Heat (from cool) after the error integrator exceeds 900°F seconds or Space Temperature  $\leq$  (Heat Setpoint - 1°F).

## Space Temperature Control Units

Single Zone VAV and Constant Volume Space Temperature units use the Space Temperature Control sequence of operation in Occupied Heat and Occupied Cool modes of operation; however, the Discharge Air Control method is used for all other modes. The table below summarizes each mode of operation and the control method applied. See Operating Modes section for more details

**Table 35. Mode of operation and applied control method**

Heat Cool Mode	Control Method	Discharge Air Temperature Setpoint	Space/Discharge Setpoints
Cool	Space Temperature Control	Calculated (cascade)	Space Temperature Setpoint Active Discharge Air Temperature Setpoint Active
Heat	Space Temperature Control	Calculated (cascade)	Space Temperature Setpoint Active Discharge Air Temperature Setpoint Active
Morning Warm Up	Discharge Air Control	Fixed	Morning Warmup Setpoint Discharge Air Heating Setpoint Active
Pre Cool	Discharge Air Control	Fixed	Pre Cool Setpoint Discharge Air Cooling Setpoint Active
Night Purge	Discharge Air Control	Fixed	
Unoccupied Cool	Discharge Air Control	Fixed	Unoccupied Cooling Setpoint Discharge Air Cooling Setpoint Active
Unoccupied Heat	Discharge Air Control	Fixed	Unoccupied Heating Setpoint Discharge Air Heating Setpoint Active

## Single Zone VAV

Single Zone VAV equipment is configured with a variable speed supply fan that modulates with Space Temperature Control to minimize fan energy while maintaining space comfort. When there is no demand for heating or cooling the supply fan operates at the minimum speed setting while providing ventilation according to occupancy setpoints. Alternately, the supply fan can be setup to cycle off when there is no demand for heating or cooling.

### Single Zone VAV – Cooling

**Cool** — When there is a space cooling demand, DX cooling will initialize and increase to satisfy space temperature. The supply fan will continue to operate at a low, fixed speed at low cooling capacities until the cooling capacity requires additional airflow to keep compressor operation optimal. The supply fan speed will increase as the demand for cooling capacity increases. The minimum supply fan speed is calculated by DX cooling capacity. As the space requires additional cooling capacity, Space Temperature Control will calculate a lower discharge air temperature setpoint increasing DX cooling which in turn

increases the supply fan speed (to prevent coil frost). Cooling capacity and supply fan speed both can increase to 100%.

If the unit discharge air temperature reduces to the Discharge Air Temperature Minimum Cool Limit setting or DX cooling reaches 100% capacity, cooling capacity increases will hold while the supply fan speed will continue to increase to 100% or modulate to manage space comfort cooling.

**Cool Economizer** — If the unit is configured for a modulating outdoor air damper and conditions are suitable for economizer cooling, the supply fan will operate at minimum speed while the economizer damper modulates between the Outdoor Air Damper Minimum Position (or Flow) Setpoint and 100% to satisfy the discharge air temperature setpoint. If the economizer damper reaches 100% open and additional cooling capacity is required, the supply fan will then modulate between minimum speed and 100% to provide additional cooling to the space.

**Cool Economizer + DX** — Cool – Economizer + DX is reported as the Unit sub-mode of operation when both

economizer and DX cooling are active. If actively economizing, outdoor air damper is 100% and supply fan speed reaches 100% then DX cooling will be added if the unit is not satisfying space cooling requirements.

If DX cooling is active and economizer cooling enables, the control will transition to increase economizer damper above minimum position (or flow setpoint) to 100% to satisfy space cooling while decreasing DX cooling. DX cooling will steadily be removed as long as economizer cooling is able to satisfy the cooling load. The supply fan operates to the lowest speed possible during the transition.

### Single Zone VAV – Heating

The supply fan operates at minimum speed (or will cycle off) when the space has no heating demand. When space temperature control calculates an increasing demand for heat in the space, the calculated discharge air temperature setpoint will increase. When heating capacity initiates, the supply fan will operate at the required minimum speed for the heat type installed. The minimum fan speed can be 100%. See Heat Types for more information.

As the Discharge Air Temperature Setpoint increases, the heat capacity increases stages and/or modulates. The control manages heating capacity to deliver a discharge air temperature to the Discharge Air Temperature Setpoint within the control deadband. If the unit discharge air temperature reaches the Discharge Air Temperature Maximum Heat Limit, heating capacity will hold and the supply fan will further increase (if possible) to satisfy the space heating demand.

### Compressor Staging and Timers

There are timers associated with compressor staging control to optimize refrigeration system performance:

- Minimum OFF Time
- Minimum ON Time
- Inter-Stage Time

**Minimum OFF Time** — For each compressor (fixed or variable speed), when the compressor has been turned OFF for any reason, a timer will be started for that compressor(s). The compressor(s) will not be allowed to be turned back ON until their timer has expired.

**Minimum ON Time** — Once a compressor has been turned ON a timer will be started for that compressor. The compressor will not be allowed to be turned back OFF until its timer has expired. A normal stop request (user interface Stop, normal shutdown diagnostic, Off mode) will honor the Minimum ON Time and keep the compressor on until the timer expires

**Important:** *Any Immediate stop request or Immediate Shutdown diagnostic will override any minimum on time and shut the compressor off immediately.*

**Inter-Stage Time** — For normal unit operation the timing between stages will be maintained at a minimum of a fixed Inter-stage Time. The compressor control algorithm may

request staging to occur beyond 3 minutes but the time span from one stage turning ON(OFF) until the next compressor stage turning ON(OFF) will be no less than the 3 minute inter-stage time. Rapid Restart and manual compressor control can override this time.

### Supply Fan Delay

A 60 second supply fan off delay is enforced after the last compressor de-energizes.

### General Compressor Staging

Compressor staging will occur based on the unit's algorithms cooling capacity request and the specific Compressor Staging Table defined per the unit's configuration. When the request is ADD, the next highest stage sequence will identify which compressors will be turned ON, or OFF if a 'Double Swap' is required. When the request is SUBTRACT, the next lowest stage sequence will identify which compressors will be turned OFF, or ON if a 'Double Swap' is required. Capacity Control limits may also affect staging sequence.

### Double Swap

To meet efficiency or optimized capacity requirements, it will be necessary on some units, when staging up or down, to turn ON one compressor and, for the same stage, to turn OFF another compressor.

### Compressor Proving

- Fixed Speed Compressors: The compressor contactors have an auxiliary contact that is wired to a compressor proving input.
- Variable Speed Compressors: The variable speed compressor VFD has an integrated Run Inhibit binary input wired to a second HPC (High Pressure Cutout) switch. When this HPC switch opens the VFD will be stopped and the run proving status will be communicated back to the controller.

### Variable Speed Compressor Optimal Start

This circuit-level feature applies to the variable speed compressor and enforces a maximum speed limit for a fixed time period following startup. During normal operation the speed range limits are determined based on unit type, efficiency, capacity stage and other limit controls. The maximum speed limit applies to every startup to maintain oil quality. When this function is active, an indication will be made to the user interface

### Evaporator Coil Surface Utilization (Two Circuit Units Only)

All staging sequences performed by the algorithm energize compressors on each circuit as soon as possible to optimize cooling efficiency. If a circuit 1 compressor starts first, a circuit 2 compressor starts second if it is available. If a circuit 2 compressor starts first, a circuit 1 compressor starts second if it is available.



### Compressor Lockout and Inhibit

In all cases of Lockouts, Inhibits, and Limits (Compressor Minimum OFF Time is not considered a lockout or inhibit) Alternate Staging Sequences will be substituted.

#### Compressor Lockouts

Compressor lockouts are typically non-recoverable and require user interaction at the User Interface to clear associated diagnostics that return the compressor(s) to operation. Other compressor lockouts will recover automatically when the lockout command is removed.

#### Compressor Inhibits

Inhibits of compressors are typically recoverable without requiring user interaction. The inhibit of a compressor will be immediate once the request is issued. Inhibits originate from undesirable refrigeration operating conditions and may or may not be associated with a diagnostic event. Once the condition has recovered, the compressor will be un-inhibited and will be available for staging sequences.

### Alternate Staging Sequence

When one or more compressors are unavailable due to Lockouts and Inhibits, an alternate staging sequence will be determined from a rule-based algorithm which selects the best next stage from the available compressors. Double Swaps will not be performed during Alternate Staging Sequence.

#### Staging Up

On single circuit units, two circuit units with neither circuit active, or two circuit units with both circuits active, the smallest available compressor will be selected to start.

On two circuit units with one circuit active, the smallest available compressor on the non-active circuit will be chosen to start. If none are available on the non-active circuit the next smallest available compressor on the active circuit will be chosen to start.

#### Staging Down

On single circuit units, or two circuit units with one circuit running, the largest running compressor will be chosen to stop.

On two circuit units with both circuits active, the largest running compressor that will not cause a circuit to stop will be chosen. If there is only one compressor running per circuit the larger of the two compressors will be chosen to stop.

#### Transition Out of Alternate Staging

Transition to Normal Staging — When all compressors are available on the next request to add or subtract the current state will be evaluated against the Normal staging table. If a match is found, the next staging decision will be made following the Normal staging rules. If the normal table does not contain a match for the current state, then the Alternate Staging sequences will be used to process the command, and the cycle will continue until a match has been found.

Transition to Balanced Compressor Staging — Balanced Compressor Staging is a feature setting, when enabled

balanced staging rules will be used to process the next staging request.

### Compressor Staging with Variable Speed Compressors

Units with Variable Speed Compressors will always attempt to start the variable speed compressor first. Subsequent stage increases start the preferred compressor next according to the default factory staging sequence. Special consideration during Alternate Staging Sequences are defined as follows:

#### VSC Available During Alternate Staging Sequences

During inhibited fixed speed compressor operation, the VSC will be utilized over its full range of designed speed operation prior to a stage change. Stage change logic will be determined based on the available compressors following alternate staging rules.

#### VSC Inhibited During Alternate Staging Sequences

During inhibited VSC operation, stage change logic will be determined based on the available fixed stage compressors. If the circuit with the inhibited VSC also has fixed stage compressors, (FSC) these compressors will be available for the alternate staging sequence. All FSC must be staged OFF before the non-inhibited VSC will become available. When the VSC becomes available, it will be the first compressor turned ON at the next ADD request.

### Balanced Compressor Staging

The Balanced Staging function is a user-defined option for fixed-speed compressor units. To perform Wear Balancing, the Symbio 800 controller will keep track of each installed compressor' number of starts, and run-time. The controller will use this information to equalize wear across all compressors installed in the unit. Double Swaps will not be performed during Balanced Compressor Staging The Balanced Compressor Staging function can be Enabled or Disabled at the user interface. When disabled, compressor staging follows the Normal Staging Sequence.

#### Wear Balancing Calculation

The wear balancing formula for compressor operation is the number of compressor starts multiplied by a factory determined wear factor, plus all of the normal run time. Starting accounts for a significant amount of normal run time wear and adds quickly to the wear calculation sum.

#### Ties

If multiple compressors with equal wear are available for the next stage, the smallest compressor will start. The largest compressor will stop.

If Balanced Starts is Disabled from the user interface, compressor staging follows the factory staging sequence. The nominal unit size configuration setting maps to the factory staging sequence selection.

### Compressor Protections

There are a number of functions which provide protection of the refrigerant systems during compressor operation.

These protections typically involve reducing, if not completely removing, one or more compressors from operation on a given refrigeration circuit. There are basically two types. The first are Lockouts which are those associated with diagnostics and are persisted until human intervention or significant unit mode change occurs. The second are Inhibits which are typically temporary, self-correcting, and may not involve a diagnostic.

Working in concert with compressor protection are the general algorithms of compressor staging (timing) as well as refrigeration and electrical capacity control.

### Low Ambient Lockout

Low Ambient Lockout prevents compressor operation when Outdoor Air Temperature Active falls below an adjustable setpoint. The low ambient lockout setpoint range and default value is dependent on unit configuration. When the outdoor air temperature rises above the Low Ambient Lockout Setpoint + 5°F, inhibit will be removed and the compressors will be available.

### Low Compressor Suction Pressure Protection

The Low Compressor Suction Pressure diagnostic, Low Compressor Suction Pressure Start Inhibit, and Low Compressor Suction Pressure Limit work together to prevent damage to compressors and suction cooled compressor motors operating with little or no refrigerant charge.

The Low Compressor Suction Pressure diagnostic protects against an inadvertent compressor start when the system is in a vacuum (such as can be produced during service procedures). It also avoids compressor failures and extremely inefficient operation due to total charge loss. The Low Compressor Suction Pressure diagnostic will shut down the affected circuit, if already running, when the circuit's Compressor Suction Refrigerant Pressure measurement drops below a factory determined pressure threshold value for normal operation (normal threshold value). When the circuit is not running, and for a period of time (in seconds) immediately after the circuit starts running, the effective start-up pressure threshold is lower than the normal threshold value. These values are dependent on unit model.

The Low Compressor Suction Pressure Start Inhibit and Low Compressor Suction Pressure Limit work together to reduce the likelihood of Low Compressor Suction Pressure diagnostic, which will lock out the circuit and force a manual diagnostic reset. When either functions are active, an indication will be made to the user interface.

The Low Compressor Suction Pressure Start Inhibit is designed to prevent a circuit from starting when low compressor suction pressure exists, but will not shut down a circuit that is already running. When the function is in the Active state, the circuit will be prevented from operating (locked out). The threshold value for this function is 1.2 times the normal threshold value.

Low Compressor Suction Pressure Limit only applies to circuits which have more than 1 compressor installed. This function prevents the addition of circuit capacity any time the circuit is running and Compressor Suction Refrigerant Pressure is less than 1.4 times the normal threshold value.

### Temperature and Pressure Sensor Failures

Each refrigeration circuit has a number of sensors that are required for proper control of compressors and associated head pressure control components. Should these sensors fail, or exceed operational limits, compressors on the given circuit will be inhibited until the sensor values return to normal operational ranges. An indication will be made to the user interface.

### Compressor Discharge Pressure Limit

Compressor Discharge Pressure Limit is a control feature of Adaptive Control. This feature prevents a circuit shutdown when the discharge pressure approaches the high pressure cutout switch setting by decreasing compressor capacity. This is done by staging off fixed speed compressors on circuits with high discharge pressure. This feature will provide maximum capacity while preventing a high pressure cutout.

The discharge pressure limit is based on the discharge pressure percentage relative to the high-pressure cutout setting. This limit is active when the circuit is running.

If the discharge pressure limit is preventing loading, holding or forcing unloading, an indication will be made to the user interface.

**Note:** *Note: The discharge pressure limit function assumes that all available condenser fans are running and limiting compressor capacity is the only option left.*

### Compressor Discharge Saturated Temperature Limit

Compressor Discharge Saturated Temperature Limit is a control feature of Adaptive Control for variable speed compressors only. This circuit-level feature applies when the discharge saturated temperature approaches the compressor operating threshold limit for high discharge saturated temperature. Limit control action modifies the normal capacity modulation to decrease capacity by reducing compressor speed.

### Compressor Discharge Saturated Temperature Speed Limit

Compressor Discharge Saturated Temperature Speed Limit is a control feature of Adaptive Control for Danfoss VZH variable speed compressors only. This circuit-level feature applies when the discharge saturated temperature approaches the compressor operating threshold limit for high discharge saturated temperature. Limit control action modifies the allowable compressor speed range.

### High Suction Saturated Temperature Inhibit

High Suction Saturated Temperature Inhibit is a control feature of Adaptive Control for variable speed



## Unit Startup

---

compressors. This circuit-level feature applies when the suction saturated temperature exceeds the compressor operating threshold limit for suction saturated temperature. Inhibit control action de-energizes the variable speed compressor when the suction saturated temperature exceeds the operating threshold design limit.

When this function is Active, an indication will be made to the operator.

### Compressor Involute Pressure Differential Protection

Compressor Involute Pressure Differential Protection is a control feature of Adaptive Control for variable speed compressors. Scroll compressors have a limitation on the pressure difference between the opposite sides of the involute tip near the center of the scroll (compression ratio). High values of compressor involute pressure differential may cause compressor fatigue. Its associated limit will attempt to allow the unit to run safely at partial capacity without tripping the circuit on a diagnostic. The compressor must be restricted from running in this condition.

When this function is active, an indication will be made to the user interface. Depending on severity, both instant and delayed shutdowns are possible. Shutdowns may be temporary or require a manual reset.

### Loss of Charge Detection

This function detects excessive refrigerant leakage. Units can operate in a low charge condition for an extended period where the loss of charge is not enough to trigger the normal loss of charge protection. If the charge continues to fall slowly, a subsequent start could result in variable speed compressor damage. Loss of Charge Detection works in concert with Superheat High Limit Detection.

### Superheat High Limit Detection

A unit may experience refrigerant leakage at any point in its service life. Moderate refrigerant loss reduces capacity and causes low suction saturated temperature but excessive refrigerant loss may lead to compressor damage. Excessive refrigerant loss is detected by a suction superheat condition which exceeds a high limit threshold.

This function detects excessive refrigerant loss by comparing suction superheat to a high limit threshold. The detection method reduces the potential for nuisance trips by providing a startup delay time that is a function of the outdoor air temperature.

This approach helps to mitigate false detection trips because low suction saturated temperature and high superheat is normal following startup at low outdoor air temperature conditions.

When this function is active, an indication will be made to the user interface and the circuit will shutdown.

### Variable Speed Compressor Modulating Current Limit

This Adaptive Control action will first reduce variable speed compressor RPM which, in turn, reduces discharge

pressure. This will reduce the variable speed compressor motor current thus preventing an A49 Speed Limit VFD trip. This function works in concert with Current Limit Staging Command which can subtract, hold or allow adding compressor capacity. When this function is active, an indication will be made to the user interface.

### Compressor Low Suction Saturated Temperature Speed Limit

This is an Adaptive Control feature for variable speed compressors. Low suction saturated temperature can occur following startup at low outdoor air temperature conditions. This circuit-level feature applies to variable speed compressors and enforces a minimum and maximum speed limit.

### Coil Frost Protection

This is a circuit level protection and is active whenever one or more compressors on a circuit are running. This feature is always available with all compressor types.

As frost builds on a coil, thermal resistance increases and airflow decreases. Frost buildup on the coil can also cause instabilities in superheat control. If suction saturated temperature drops below a threshold, Frost Protection will inhibit capacity in an attempt to melt the frost and allow the unit to run more efficiently. Once the frost is removed the unit will be returned to normal operation. To avoid nuisance trips at startup, a "ignore" time delay is applied. The delay time is variable and is based on outdoor air temperature

Modulating Coil Frost Limit Control applies to circuits with a variable speed compressor. This function will limit variable speed compressor capacity according to evaporator coil frosting conditions. If the suction saturated temperature (SST) is sufficiently above the Coil Frost Threshold, the Symbio 800 reverts to normal control.

Modulating Coil Frost Limit Control is active following compressor startup and is not subject to the ignore time.

There are no diagnostics for this feature. When this function is active, an indication will be made to the user interface.

### Head Pressure Control

The refrigeration system will utilize condenser fan control to maintain the discharge pressure of operating compressors on a given circuit to desirable levels. Pressure sensors will be utilized to provide the control signal. As the pressure of the condenser section increases more stages of fan capacity will be used to prevent excessive operating conditions that could open the High Pressure Cutout switch causing nuisance trips of the refrigeration circuit. Condenser fan capacity will be reduced to prevent excessive low pressures that could cause un-stabilized refrigeration conditions. A unit can have up to two refrigeration systems (circuits) that are completely isolated from each other and are controlled independent from each other.



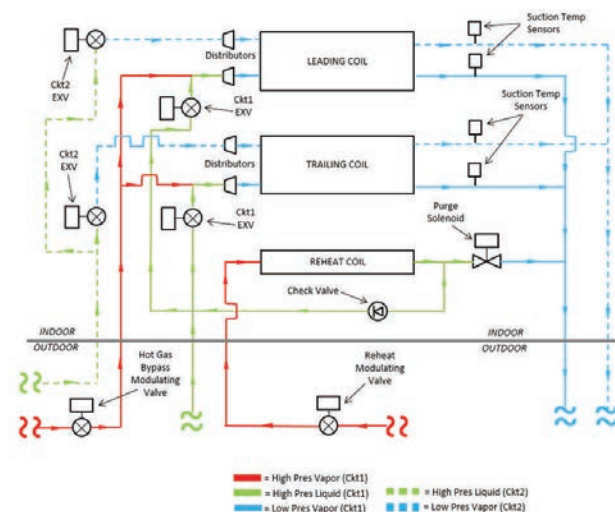
## Low Ambient Operation

Units configured with Low Ambient Operation use a modulating condenser fan for the first stage.

## Hot Gas Bypass

Hot gas bypass is a unit configuration option that, at some predetermined suction pressure, initiates a modulated flow of hot refrigerant gas from high side to the low pressure portion of the refrigeration system. This adds “false load” to avoid low suction pressures that would otherwise result in coil frosting. This feature can be disabled, but when enabled is transparent to the normal staging control provided by the Symbio 800 controller. Regardless, Hot Gas Bypass operation indirectly places operating constraints on the system that have to be addressed by the unit controls in the areas of EXV superheat control and dehumidification/reheat operation.

**Figure 41. Piping diagram with hot gas bypass**



## Hot Gas Bypass Control

### Activation

If a unit is configured with hot gas bypass, the hot gas bypass system is functional whenever circuit 1 is operating. The hot gas bypass valve is closed during normal operation. The valve will open, passing the amount of hot gas required to produce a suction pressure that is high enough to prevent coil frosting, when necessary. If Hot Gas Bypass Enable is Disable, the Hot Gas Bypass valve is always closed.

### Interaction

Hot Gas Reheat and Hot Gas Bypass options are installed on circuit 1, however, hot gas bypass is not allowed to operate if the “Hot Gas Reheat Valve Reheat” is open (>0%). The hot gas bypass valve will open when suction pressure is lower than the calculated target. In addition, the valve control has interactions with coil defrost protection, EXV control and condenser fan control.

### HGBP Valve Calibration

HGBP valve calibration (also known as overdrive closed) procedure is initiated in the following circumstances:

- Whenever the unit controller is power cycled. This is under the control of the unit controller software, as part of the software startup procedure. Note: under the most common scenario when both the HGBP valve electronic controller and unit controller are power cycled, HGBP valve recalibration may occur twice.
- When the circuit cycles off and the circuit has run for at least EXV Recalibration Time since the previous calibration.

**Note:** EXV calibration time is used for both HGBP and EXV valve calibration.

- Whenever the HGBP valve electronic controller is power cycled. The HGBP valve electronic controller does this automatically.

## EXV Control (Electronic Expansion Valve)

Electronic expansion valves (EXVs) control suction superheat to ensure the complete and efficient evaporation of refrigerant in the evaporator. Excess liquid refrigerant in the compressor suction (low suction superheat) can be harmful to the compressor, and a deficit of liquid in the evaporator (high suction superheat) is inefficient. The benefit of EXV control, through controlling suction superheat, suction pressure, suction saturated temperature, or pressure ratio, promotes energy-efficient operation and long-term reliability of the compressor(s).

Suction superheat is the difference between suction temperature and saturated suction temperature. A temperature sensor measures suction temperature. The saturated suction temperature is determined from the measured suction pressure by a refrigerant property calculation. Typically, the EXV control maintains a small, desired amount of suction superheat by opening or closing the EXV(s), which adjusts the refrigerant flow rate into the evaporator.

In certain situations, such as cold ambient starts, warm supply air starts, the EXV control can automatically move into a suction pressure control mode, allowing the suction superheat to deviate from the superheat setpoint. The goal of the suction pressure control mode is to maintain suction pressure or differential pressure within the compressor operating map.

In situations where the superheat rapidly falls to very low values, special control modes are necessary to dry out excess refrigerant liquid in the evaporator, suction line, and compressor sumps, and transition back to normal control.

## Configuration

Electronic Expansion Valves are always installed on DX refrigeration circuits. Configuration is used to specify the EXV selection on each refrigeration circuit. EXV selection allows picking of a correlation between EXV steps or EXV percent open, and the flow coefficient ( $C_v$ ) at each EXV opening.



## Unit Startup

### Functional Description

#### EXV Calibration

An EXV Calibration (also known as overdrive closed) procedure will be initiated in the following circumstances:

- Whenever the unit controller is power cycled. This is under the control of the unit controller software, as part of the software startup procedure.

**Note:** Under the most common scenario when both the EXV electronic controller and unit controller are power cycled, EXV Calibration may occur twice.

- When the circuit cycles off and the circuit has run for at least EXV Recalibration Time since the previous calibration.

**Note:** EXV calibration time is used for both HGBP and EXV valve calibration.

- Whenever the EXV electronic controller is power cycled. The EXV electronic controller does this automatically.

#### EXV Manual Override Control

See Programming Guide

#### EXV Control Sequence of Operation

The EXV control algorithm can be in one of the following states:

**Table 36. EXV Control States**

Control State	Description
Stopped	EXV closed. Overdrive closed (calibration) performed if criteria are met.
Starting	EXV pre-position is calculated, and the valve arrives at the requested opening before any compressors on the circuit start.
Stopping	EXV commanded to close. Remain in state until EXVs report that they are closed.
Running	EXV operates in pre-start control, or in automatic control after the pre-position hold time expires.
Running Mode Sub-States	Description
Running – Wait for Circuit Start	Time after valve arrives at pre-position value, but before a compressor on the circuit starts.
Running – Pre-Position Hold Time	After a compressor on the circuit starts, but before automatic control begins.
Running – Suction Superheat Control	Normal automatic superheat control
Running – Suction Pressure Control	Controlling suction pressure instead of suction superheat, to maintain adequate compressor pressure ratio or to limit high suction saturated temperature.
Running – Evaporator Dryout Control	Special version of suction pressure control, to dry out a flooded evaporator and prepare to control suction superheat or suction pressure again.

### Operating Modes

#### Calibrating\_EXV

Circuit submode displayed when EXV is going through the calibration process. Most often active when circuit top-level mode is Stopped, Run Inhibit, or Auto.

#### Prepositioning\_EXV

Circuit submode displayed when EXV(s) are moving toward their commanded pre-position opening prior to starting the first compressor on circuit startup.

#### Manual\_Override\_Evaporator

Displayed when performing manual control override on the EXV in the Evaporator position.

#### Economizing

Symbio 800 supports a a single outdoor air / economizer damper. Economizer high-limit decision methods are defined as follows.

**Table 37. Economizer high-limit decision methods**

Fixed Dry Bulb	Enable	Outdoor Air Temperature < Economizer Outdoor Air Enable Setpoint – 5°F
	Disable	Outdoor Air Temperature > Economizer Outdoor Air Enable Setpoint
Reference Enthalpy + Fixed Dry Bulb	Enable	Outdoor Air Enthalpy < Reference Enthalpy Setpoint – 3 BTU/lb AND Outdoor Air Temperature < Economizer Outdoor Air Enable Setpoint – 5°F
	Disable	Outdoor Air Enthalpy > Reference Enthalpy Setpoint OR Outdoor Air Temperature > Economizer Outdoor Air Enable Setpoint
Comparative Enthalpy + Fixed Dry Bulb	Enable	Outdoor Air Enthalpy < Return Air Enthalpy – 3 BTU/lb AND Outdoor Air Temperature < Economizer Outdoor Air Enable Setpoint – 5°F
	Disable	Outdoor Air Enthalpy > Return Air Enthalpy OR Outdoor Air Temperature > Economizer Outdoor Air Enable Setpoint
Differential Dry Bulb	Enable	Outdoor Air Temperature < Return Air Temperature
	Disable	Outdoor Air Temperature > Return Air Temperature

When conditions are suitable for economizer operation, the outdoor air damper modulates between Economizer Minimum Position (or Flow) Setpoint and 100% open. Economizing will not allow additional mechanical cooling until the damper position is 100% and supply fan has reached 100% capacity. If economizer cooling becomes disabled, damper will revert to minimum position (or Flow) control, and transition to mechanical cooling.

Given the economizer decision methods above, if Comparative Enthalpy + Fixed Dry Bulb is configured and the return air or humidity sensor goes out of range or fails, a fallback method of Fixed Dry Bulb or Reference Enthalpy + Fixed Dry Bulb is selectable in the user interface Feature Settings screen.

A building automation system can directly command economizer operation via Economizer Airside Enable (auto, enable, disable). If commanded Enable, the controller will start economizer cooling, regardless of outdoor air conditions. If commanded Disable, economizer cooling will be disabled (except if a mode of Night Purge is commanded to the controller). If commanded Auto, the controller will use the configured Economizer high limit method and input values to determine if economizer cooling is available.

## Outdoor Air Damper Fault Detection and Diagnostics (FDD)

The outdoor air damper fault will have two fault detection components, faults that are generated when operating in minimum ventilation mode and another set when the damper is being controlled by the economizer:

### FDD: Excessive Outdoor Air

In minimum ventilation mode and the damper feedback position is >10% of the damper commanded value for 5 continuous minutes.

### FDD: Outdoor Air Damper Not Modulating

In minimum ventilation mode and the damper feedback is <10% of the damper commanded value for 5 continuous minutes.

### FDD: Unit Economizing When It Should Not

In economizer cooling mode and the damper feedback is >10% of the damper commanded value for 5 continuous minutes.

### FDD: Unit Not Economizing When It Should

In economizer cooling mode and the damper feedback is <10% of the damper commanded value for 5 continuous minutes.

## Dehumidification Control - Occupied

Dehumidification control is a sub-mode of Cool when hot gas reheat is configured and the dehumidification feature is enabled. There are two methods for controlling dehumidification: Space Relative Humidity or Space Dew Point. A valid Evaporator Leaving Air Temperature sensor (s) is required for either method.

For both methods upon demand for dehumidification, the unit will drive the outdoor damper to minimum position (or closed during unoccupied periods) and will drive mechanical cooling capacity to an evaporator leaving air setpoint and modulate the reheat valve based on discharge air reheat setpoint which is reset based on space temperature or directly by a commanded reheat setpoint.

## Relative Humidity

When a valid space relative humidity value is above the Space Dehumidification Setpoint, dehumidification control is invoked. Economizer cooling disables. The sub-mode Cool – Dehumidification is reported on the user interface Operating Modes screen.

Dehumidification control disables when space relative humidity is less than Space Dehumidification Setpoint minus the Occupied Dehumidification Offset, Heat Cool



## Unit Startup

Mode Status is not Cool, or a sensor required for dehumidification control is invalid.

### Dew Point

If space dew point is greater than the space dew point setpoint (default = 60F) and outdoor air dew point is greater than the outdoor air dew point threshold (default = 60F), the unit enters dehumidification.

In addition to a space humidity sensor, an outdoor air humidity sensor is also required.

### Discharge Air Control Units

When Dehumidification is active, cooling capacity is controlled by Evaporator Leaving Air Temperature relative to Evaporator Leaving Air Temperature Setpoint. This setpoint is suitable to satisfy the space humidity load. Cooling capacity will first load on circuit 1 to provide hot gas reheat capacity. The Hot Gas Reheat valve modulates to manage reheat capacity to satisfy the Discharge Air Temperature Setpoint.

Optionally, a building automation system can set the Discharge Air Reheat Setpoint. This then becomes the target setpoint for hot gas reheat control, when dehumidification is active. Likewise, Evaporator Leaving Air Temperature Setpoint can be written for dehumidification control.

### Space Temperature Control Units

Space temperature units internally use dew point to manage space humidity control. When hot gas reheat is inactive, the cooling control calculates a suitable setpoint to manage both space temperature and space humidity. If space temperature falls below the space cooling setpoint minus a fixed differential, the hot gas reheat valve modulates to maintain space temperature control. The evaporator leaving air temperature setpoint is calculated to control humidity independent of space temperature. Optionally, a building automation system can set the Evaporator Leaving Air Temperature Setpoint to control DX cooling capacity.

## Dehumidification Control - Unoccupied

Unoccupied Dehumidification control sequence of operation is the same for all unit types when the controller is in unoccupied mode, hot gas reheat is configured, and the unoccupied dehumidification feature is enabled. Typically, the unit is off when in unoccupied mode. However, dehumidification control will start unit operation under the following conditions:

- When a valid space relative humidity value rises above the Space Dehumidification Unoccupied Setpoint, and Space Temperature is above a fixed 64°F threshold.
- Or when Space Dew Point is greater than Space Dew Point Unoccupied Setpoint AND Outdoor Air Dew Point is greater than Outdoor Air Dew Point Threshold.

Economizer cooling disables and the sub-mode Cool – Dehumidification is reported on the user interface Operating Modes screen.

When Dehumidification is active, cooling capacity is controlled by Evaporator Leaving Air Temperature relative to Evaporator Leaving Air Temperature Setpoint. This setpoint is suitable to satisfy the space humidity load. Cooling capacity will stage to satisfy the evaporator cooling demand. The hot gas reheat valve modulates to maintain a space temperature setpoint.

Unoccupied Dehumidification control disables when:

- Space relative humidity is less than Space Dehumidification Unoccupied Setpoint minus Unoccupied Dehumidification Offset or Space Temperature falls below a fixed 60°F threshold
- Or Space Dew Point is less than Space Dew Point Unoccupied Setpoint minus Space Dew Point offset.

## Heat Types

Variable speed supply fan operation is different depending on the heat type installed. Some heat types require the supply fan to be at full speed. Other heat types allow modulating supply fan speeds in specific operating modes. The table below summarizes Multi Zone-VAV supply fan operation where Modulating means Duct Static Pressure Control.

**Table 38. Multi zone-VAV unit – Supply fan operation**

	Staged Gas	Modulating Gas	Staged Electric Heat	External Heat
Occupied Heat	Full	Modulate	Modulate	Modulate
Maximum Heat	Full	Full	Full	Full
Morning Warm Up	Full	Full	Full	Modulate
Daytime Warm Up	Full	Full	Full	Modulate
Unoccupied Heat	Full	Full	Full	Modulate
Occupied Cool Supply Air Tempering	NA – not allowed	Modulate	Modulate	NA

Single Zone-VAV units have limited supply fan speed modulation in Occupied Heat modes of operation when

modulating gas heat or modulating electric heat are

configured; otherwise, the supply fan operates at full capacity in all other heat operating mode

All heat types, when the control terminates heating capacity or exists a heating mode; a 5-minute post heat timer is enforced. This keeps supply fan On to remove heat from the unit before transitioning to a cooling mode or cycling the supply fan off.

## Gas Heat

There are two types of gas heat available: Staged and Modulating. Burners will not turn on if the heater minimum off timer is active, the heater inter-stage timer (three minutes) is active, or modulating heater is not at maximum rate.

## Gas Heat Sequence

Call for heat initiated

1. A call for heat is initiated by a relay.
2. Inducer pressure switch is open prior to starting the inducer fan.
3. The inducer fan is started, and pressure switch is tested for closure. The supply fan proving switch and inducer fan proving switch must be closed within 10 seconds of energizing the inducer fan to initiate pre-purge for 60 seconds.
4. Ignition speed is reduced to ignition level and trial for 1.5 seconds.
5. Flame is detected and stabilized.
6. Heater is Stage 1 for staged or minimum fire for modulating.
7. Stage 2 Enable, requests the second stage of heat from the gas heat controller.

While heat operation is in progress, the gas heat controller is monitoring the flame, inducer fan, and thermal limit switch. If any of these items open, a lockout code is set.

## Unexpected Shutdown

If an unexpected shutdown occurs when the gas heat controller reflects standby without an error code, an unexpected shutdown diagnostic is set. This can happen when there is a component failure upstream of the gas heat controller.

## Lost Gas Heat Flame

If flame is lost, the gas heat controller shuts down and requires a reset to clear the lockout. After clearing the lockout, the unit controls request a retry for ignition. If after three unsuccessful attempts to re-ignite the heater, a manual lockout is set, and diagnostic communicated. This diagnostic will auto reset after 90s, and heat will be allowed to attempt to start again if requested due to temp control.

If gas/flame is not detected, such as air in lines, a failure to start diagnostics is set.

## Failure to Start

If pre-purge is not detected within 60 seconds, after request for Stage 1 or minimum fire, it indicates a problem where the gas heat controller is not receiving the heat enable signal. A diagnostic message of "heater failed to start" is set. No retries are attempted.

"Heater failed to start" diagnostic also sets if starting is not proven within six minutes of closing the enable relay if no other diagnostics occur. This allows for the retries due to failure to prove flame at ignition and covers any unforeseen sequence issues at startup.

If the gas heat controller does not sense a flame after an ignition attempt, it will lockout (NO FLAME AT END OF TRIAL FOR IGNITION) and a corresponding non-latching diagnostic is called out. The diagnostic is reset after 90 seconds and then another request for ignition is initiated. If after three attempts, a successful ignition is not achieved, heat is locked out and a latching diagnostic set.

- The 90 second delay to auto reset the diagnostic begins when the Symbio controller receives communication for the failed ignition lockout and sets the diagnostic. 90 seconds allows for post purge and other delays.
- The enable relay stays closed throughout the retries and delays.
- At the end of the 90 second delay, a reset command is sent to the gas heat controller through the reset relay output which causes the lockout and diagnostic to clear.
- Check for Failure to Start detection is performed only on first attempt.
- If while in the 90 second delay the diagnostic is reset through user interface or externally, the delay is canceled and retry is attempted.
- The retry count is reset by either: a successful start, removal of call for heat, occurrence of lockout diagnostic, or power cycle of Symbio.

## Call for Heat Terminated

When the unit has determined the request for heat is no longer required, the enable signal is removed and the gas heat controller will de-energize the valve and the inducer fan starts its 60-second post purge.

## Electric Heat - Staged

When staged electric heat is configured in the unit, the controller manages four binary outputs to provide up to eight-stages of heat control; depending on size of the electric heat installed. If four or less electric heat stages are installed, the binary outputs are energized in sequence to add additional heat capacity. If more than four electric heat stages are configured, the binary outputs are energized in combination to provide increasing heating capacity with each stage.



### Electric Heat Protection

There are three automatic high temperature limit switches that will trip when exposed to a high temperature. They will reset automatically once the temperature drops into an acceptable range. If any one limit switch trips, all stages of heat are turned off. The limits are mounted vertically on the heater terminal plate and all three have the same temperature trip point.

A manual reset temperature limit is also mounted near the top of the terminal plate and serves as backup protection. When exposed to high temperature, it will turn all stages of heat off until the reset button is manually reset. The electric heat protections operate independently of the controller.

### External Heat

The Symbio 800 controller supports external field supplied heat sources. There is no factory wiring or coordination between the controller and external heat. When External Heat is configured, the supply fan operates as required in heat modes and provides ventilation defined by the mode.

Single Zone-VAV units have an External Heat Supply Fan Speed Setpoint (adjustable) that defines the supply fan speed in Occupied Heat modes of operation. The supply fan operates at maximum speed for all other heating modes. Continuous and cycling fan modes are both supported.

Multi Zone-VAV units operate the supply fan under duct static pressure control, unless commanded to go to Maximum Heat.

### Hydronic and Steam Heat

Hydronic and Steam Heat use an analog voltage signal (0-10V) to modulate a valve open or closed as needed to meet the heating demand.

A binary input is used to detect situations that can cause freezing in the heat exchanger and allows the controls to take preventative actions to avoid freezing and potential failure of the heat exchanger. Outdoor air temp is also monitored to help avoid freeze stat trips.

### Unoccupied Cooling

Unoccupied Cooling mode is used when the building is unoccupied and the space conditions are exceeding temperature limits. The unit is normally off in unoccupied mode. If a valid space temperature input rises above the Unoccupied Cooling Setpoint, unit operation starts unoccupied cooling to manage space temperature. The controller operates in Discharge Air Control with ventilation disabled while DX or economizer cooling capacity increases to satisfy the Discharge Air Cooling Setpoint. Multi Zone VAV units operate the supply fan with duct static pressure control, other units operate the supply fan at maximum speed. Cooling continues until space temperature is 4°F less than the Unoccupied Cooling Setpoint, the unit will then cycle off.

Unoccupied Cooling Mechanical Enable and Unoccupied Cooling Economizing Enable are settings to enable or disable cooling in unoccupied mode.

### Unoccupied Heating

When the unit is in unoccupied mode and the valid space temperature input falls below the Unoccupied Heating Setpoint, unit operation starts unoccupied heating to manage space temperature. The controller operates in Discharge Air Control with ventilation disabled while heating capacity increases to satisfy the Discharge Air Heating Setpoint. The supply fan operates according to heat type installed, see Heat Types for more information. Heating continues until space temperature is 4°F greater than the Unoccupied Heating Setpoint, the unit will then cycle off.

Unoccupied Heating Enable is a setting to enable or disable heating in unoccupied mode at the user interface.

### External Fan Control

Symbio 800 provides the ability for an external controller or program to control supply fan, exhaust fan, and outdoor air damper. This capability allows for custom programming suited for specific application needs.

### External Supply Fan Control

External supply fan control applies to variable volume supply fan equipment. Supply fan operation must prove running and any unit startup timing must expire before external control is allowed. Supply Fan Speed Control Enabled provides an enabled status when Supply Fan Speed Setpoint is in control. The controller will annunciate External Supply Fan Control on the user interface, operating modes screen when active.

Supply Fan Speed Setpoint will only override the controller's fan control in occupied Cool, Heat, and Fan Only modes of operation. All other modes (such as Morning Warm Up, Pre Cool, Daytime Warm Up) the supply fan is operated under Symbio 800 control. Supply fan speed will increase under Symbio 800 control according to heating and cooling capacity requirements; space temperature control unit configurations. Supply fan speed will decrease under Symbio 800 control when high duct static pressure limits are approached; discharge air control unit configurations.

Table 39. External supply fan control points

Object Name	Description
Supply Fan Speed Setpoint Enable	Enables supply fan speed setpoint control
Supply Fan Speed Control Enabled	Supply fan speed is control via Supply Fan Speed Setpoint. If disabled/inactive, speed control is under Symbio 800 control

**Table 39. External supply fan control points (continued)**

Object Name	Description
Supply Fan Speed Limited	Supply fan speed is being increased or decreased due to a limit control action.
Supply Fan Speed Setpoint	External supplied supply fan speed setpoint value
Supply Fan Speed Setpoint Active	Active setpoint input to supply fan speed control
Supply Fan Speed Status	Indicates the requested speed to the supply fan, 0% when fan is off.

**Table 40. Supply fan speed setpoint summary**

Supply Fan Speed Setpoint Enable	Supply Fan Speed Setpoint	Supply fan operation
Disable	NA	Fan under Symbio 800 control
Enable	0%	Commands the fan off
Enable	1% to 37% <sup>(a)</sup>	Fan operates at drive minimum Hz setting
Enable	38% to 100%	Fan ramps between drive min-Hz and max-Hz setting.

<sup>(a)</sup> For example, if drive setting is 22 min-Hz and 60 max-Hz, it will correlate to 37% reported fan speed.

### External Relief Fan Control

External Relief fan control is allowed anytime a relief fan is configured. Supply fan and relief fan operation is proven before external fan control is allowed. Relief fan operation is effectively interlocked with supply fan operation. No other control limits are applied; building static pressure high limit is not enforced.

**Important:** *A valid space static pressure sensor is not required for external relief fan control; therefore, proper building static pressure control must be considered.*

The controller will annunciate External Relief Fan Control on the user interface, operating modes screen, when active. All modes of operation are supported, except when supply fan is off. If the supply fan cycles off with capacity, the relief fan will also turn off. External relief fan speed is also interlocked with relief damper position and relief damper diagnostics. The relief damper movement will limit relief fan speed changes accordingly. The controller will impose speed limitations as required.

**Table 41. External relief fan control points**

Object Name <sup>(a)</sup>	Description	Object States or values
Exhaust Fan Speed Setpoint Enable	Enables Relief fan speed setpoint control	0 = Disable 1 = Enable
Exhaust Fan Speed Control Enabled	Relief fan speed is control via Exhaust Fan Speed Setpoint. If disabled/inactive, speed control is under local control.	0 = Disabled 1 = Enabled
Exhaust Fan Speed Setpoint	External supplied exhaust fan speed setpoint value	0 to 100%
Exhaust Fan Speed Setpoint Active	Active setpoint input to relief fan speed control	0 to 100%
Exhaust Fan Speed Status	Indicates the requested speed to the relief fan, 0% when fan is off.	0 to 100%

<sup>(a)</sup> Reference Integration Guide ACC-SVP02B (or later)

**Table 42. Relief fan speed setpoint summary**

Relief Fan Speed Setpoint Enable	Relief Fan Speed Setpoint	Relief fan operation
Disable	NA	Fan under local control
Enable	0%	Commands the fan off
Enable	1% to min speed%	Fan operates at drive minimum setting <sup>(a)</sup>
Enable	>min speed% to 100%	Fan ramps between motors min-rpm and the Relief Fan Maximum Speed Setpoint (rpm), adjustable at the unit's user interface display, service settings screen.

<sup>(a)</sup> The drive minimum RPM setting is 10 percent of nameplate rated speed. The min speed% is equal to:  $100 \times (\text{drive minimum RPM} / \text{Relief Fan Maximum Speed Setpoint})$ .

### External Outdoor Air Damper Control

To control the outdoor damper directly, via TGP2 or an external control, a setpoint can be written to Economizer Minimum Position Setpoint BAS. The controller will limit the damper movement. The commanded position reports at Outdoor Air Damper Position.

To have complete damper control, the following functions should be disabled or removed from configuration via Tracer TU or user interface display. However, the controller must be configured with an Economizer damper.

- Economizer Airside Enable Default = Disabled
- Demand Control Ventilation Enable = Disabled
- Traq Enable = Disabled



## Unit Startup

---

- Outdoor Air Flow Compensation Enable = Disable

Morning Warm Up, Pre-Cool, Night Purge, Unoccupied, and Off modes of operation will override damper minimum position to 0%.

### Overrides

The controller normally provides heating, cooling and ventilation for building comfort. The below control functions can intervene or override normal operation. These functions allow control over the IntelliPak unit as well as a means for the Service Technician to accomplish their tasks.

The order of priorities are listed. For example, an External Stop will prevent the unit from performing Ventilation Override.

1. Local Stop
2. Emergency Stop
3. Equipment Stop
4. Manual Control
5. Ventilation Override
6. Emergency Override
7. Operating Mode Off
8. Normal operating modes

If local stop, emergency stop, or equipment stop request a Stop, the unit will shut down and not resume operation until all inputs allow automatic operation.

### Local Stop

Local Stop is performed by the user interface Stop button on the user interface display. The controller will perform a Normal Shutdown process unless, the user additionally selects Immediate Shutdown at the user interface when prompted.

### Normal Shutdown Process

In a normal shutdown situation, compressors, fans, and other systems of the unit are allowed to go through an orderly shutdown sequence. For example, compressors continue to run for any remaining Minimum Run time.

If a Service Tool requires the unit to be in user interface Stop for an operation, e.g. binding, configuration, or software download, the Service Tool will send the Symbio 800 a user interface Stop command. A Service Tool screen is displayed giving the user an opportunity to allow or cancel the operation. This executes a user interface Stop command as if it had been done from the user interface including storing through a power cycle. After this occurs the only way the unit can be set back to user interface Auto is through the user interface directly.

### Immediate Shutdown Process

If an immediate shutdown is selected, compressors, fans, and all other devices are immediately stopped. A normal shutdown already in progress will be expedited. The use of this feature is discouraged since the normal shutdown cycle is provided for the normal shutdown sequence.

### Emergency Stop

Symbio 800 accepts a dry contact closure input suitable for customer connection to request Stop or Auto modes from an external device. The Emergency Stop input is normally closed which represents an Auto request.

Contact opening will perform an Immediate Stop and generate a latching diagnostic. To return to Auto operation, the input must be closed and a manual reset must be performed.

### Equipment Stop

Symbio 800 accepts a dry contact closure input suitable for customer connection to request Stop or Auto modes from an external device. The Equipment Stop binary input is normally closed which represents an Auto request.

Contact opening will perform an Immediate Stop. The unit will automatically return to Auto operation when the input is closed.

### Manual Control

Manual control is intended for servicing the machine. It provides manual control of all of all valves, dampers, actuators, fans, compressors and heating functions. This can be done while fans, compressors and heating systems are operating. Single or multiple, controls may be overridden. Remaining controls set to Auto will enforce the limits to protect the machine from damage. Diagnostics remain active to protect the machine from damage. See Programming Guide (RT-SVP011\*-EN) for further information.

**Important:** *Manual Control is for experienced service personnel.*

Manual Control can be set from the Manual Control Settings page on the user interface. Manual control varies in design but all have an automatic mode which is the default mode for most unit operation.

Once a manual override is set to manual, it will remain in manual until one of the following occur:

- Manual override is set back to automatic control by setting the individual overrides to Auto.
- Power is cycled.
- A Manual Overrides Timer expires and ALL manual overrides are cleared.
- The operator presses a Clear All Manual Overrides from the operator display or Tracer TU.

### Ventilation Override

Ventilation Override Modes (VOM) give the building controller the ability to override normal unit operation and provide special ventilation operation. VOM is initiated only at the provided five binary inputs (Mode A, Mode B, Mode C, Mode D, Mode E). When any of the normally open contacts are closed, VOM initiates specified functions such as space pressurization, exhaust, purge, purge with supply air pressure control, and unit off when any one of the corresponding binary inputs are activated. The



compressors and condenser fans, and all other components not directly controlled via VOM events, are disabled during the ventilation operation. If more than one ventilation sequence is activated, Mode A has highest priority, Mode E has lowest.

This function gives the customer the ability to override normal unit operation via a supervisory controller. Typically, these requests originate from a fire control panel. Flexibility is provided by allowing the customer to re-define each of the five responses at the user interface, along with allowing each individual response to be 'Locked' to insure expected operation is not changed. See Programming Guide for more information.

This feature is optional. When configured VOM has priority over Emergency Override, System Mode Off, and normal unit operation. The following overrides will prevent or terminate VOM operation.

- Local Stop
- Equipment Stop
- Emergency Stop
- Manual Control

When any VOM Mode (A, B, C, D, E) input is activated or closed, the VOM mode of operation will begin in less than 10 seconds, and a VOM Relay binary output will energize/close. Heating capacity, cooling capacity, and Rapid Restart will be disabled/terminated.

Refer to the table below summarizing the unit operation in response to VOM binary inputs Modes. VOM inputs are fully configurable; therefore, provides the factory default settings.

If one or more of the 5 VOM inputs are closed, the unit will enter the VOM mode with the highest priority (A highest, E lowest). Should the unit be in an active VOM mode and a VOM input of higher priority is closed, the unit will immediately transition to the higher priority mode. Should the unit be in an active VOM mode and a VOM input of lower priority is closed, the unit will not change to this lower priority mode until the current (higher priority)VOM mode binary input is opened.

When all VOM inputs are open, within 15 seconds, VOM terminates. All unit components will be reset OFF or CLOSED, and after Unit Power Up Delay is honored the unit will start normal operation.

**Table 43. Ventilation override mode**

VOM Input	OUTPUT	OPERATION	Heat Cool Mode Status
Mode A (Unit Off)	Supply fan	Off/0%	Off
	Outdoor air damper	Closed	
	Relief fan / Relief damper	Off/Closed	
	Return Fan/Relief Damper	Off/Closed	
	VAV Box Relay	Energized	
Mode B (Pressurize)	Supply fan	On/100%(a)	Fan Only
	Outdoor air damper	100%	
	Relief fan / Relief damper	Off/Closed	
	Return Fan/Relief Damper	Off/Closed	
	VAV Box Relay	Energized	
Mode C (Depressurize)	Supply fan	Off/0%	Fan Only
	Outdoor air damper	0%	
	Relief fan / Relief damper	On/Open	
	Return Fan/Relief Damper	On/Open	
	VAV Box Relay	De-energized	
Mode D (Purge)	Supply fan	On/100%	Fan Only
	Outdoor air damper	Open	
	Relief fan / Relief damper	On/Open	
	Return Fan/Relief Damper	On/Open	
	VAV Box Relay	Energized	



## Unit Startup

**Table 43. Ventilation override mode (continued)**

VOM Input	OUTPUT	OPERATION	Heat Cool Mode Status
Mode E (Purge with Duct Static Pressure Control)	Supply fan	On/Duct Static Pressure Control	Fan Only
	Outdoor air damper	Open	
	Relief fan / Relief damper	On/Open	
	Return Fan/Relief Damper	On/Open	
	VAV Box Relay	Energized	

<sup>(a)</sup> Supply fan will operate at full speed or a limited speed not to exceed duct static pressure high limit.

### Emergency Override

Emergency override provides the ability for a Building Automation System to override control of the HVAC equipment to pressurize, depressurize, purge, shutdown ventilation to the space for life safety or smoke control systems. Refer to summarizing the unit operation in response to Emergency Override commands.

### Ventilation Override Mode v/s. Emergency Override

Ventilation Override inputs/output directly connect to fire smoke control station (FSCS) panel. UUKL 864 requires that firefighters have the ability to manually override automated smoke control equipment. Manual changes from a FSCS panel will take precedence over Emergency Override from the Building Automation System.

**Table 44. Emergency override**

Emergency Override	Output	Operation	Heat Cool Mode Status
Shutdown	Supply fan	Off/0%	Off
	Outdoor air damper	Closed	
	Relief fan / Relief damper	Off/Closed	
	VAV Box Relay	De-energized	
Pressurize	Supply fan	On/100% <sup>(a)</sup>	Fan Only
	Outdoor air damper	100%	
	Relief fan / Relief damper <sup>(b)</sup>	Off/Closed	
	Return fan/Relief damper <sup>(b)</sup>	Off/Closed	
	VAV Box Relay	Energized	
Depressurize	Supply fan	Off/0%	Fan Only
	Outdoor air damper	0%	
	Relief fan / Relief damper <sup>(b)</sup>	On/Open	
	Return fan/Relief damper <sup>(b)</sup>	On/Open	
	VAV Box Relay	De-energized	
Purge	Supply fan	On/100%	Fan Only
	Outdoor air damper	Open	
	Relief fan / Relief damper <sup>(b)</sup>	On/Open	
	Return fan/Relief damper <sup>(b)</sup>	On/Open	
	VAV Box Relay	Energized	

**Table 44. Emergency override (continued)**

Emergency Override	Output	Operation	Heat Cool Mode Status
Fire	Supply fan	Off/0%	Off
	Outdoor air damper	Closed	
	Relief fan / Relief damper <sup>(b)</sup>	Off/Closed	
	Return fan/Relief damper <sup>(b)</sup>	Off/Closed	
	VAV Box Relay	De-energized	

<sup>(a)</sup> Multi Zone-VAV units will perform duct static pressure control.

<sup>(b)</sup> Return fan and Relief fan are mutually exclusive.

## Operating Mode OFF and Normal Operating Modes

See operating mode off and other normal operating modes in Operating Modes section.

## Heat/Cool Capacity Lockouts and Limits

The controller provides the following capabilities to lockout or limit all heat and cool capacity installed in the equipment. These capabilities interact. Capacity Lockouts have highest priority. When Heat Lockout Command and Cool Lockout Command are not locked-out; the control will limit capacity based on active Cooling Capacity Enable, Primary Heat Enable or Demand Limit Setpoint. The lowest commanded value will be honored.

In an example, Heat/Cool Lockouts are not active. Cooling Capacity Enable is 60%, Primary Heat Enable is 50% and Demand Limit Setpoint is 40%; DX cooling and electric heating capacity will be limited to 40%. If the unit had gas heat, heat capacity would be limited to 50%. Review each capability below for details.

### Capacity Lockouts

Capacity Lockouts are points available to the building automation network to provide a method to completely disable DX Cooling, Gas Heating and Electric Heating. Cool Lockout Command will disable all DX cooling capacity. Economizer operation is still possible. Heat Lockout Command will disable all gas and electric heating capacity. External heating is not controlled directly by the Symbio800 and will not be locked out with the Heat Lockout Command.

If both points are True (locked out) at the same time, both will be honored. Trane Graphical Programming (TGP2) can be used to control these points.

### Cooling Capacity Enable

Cooling Capacity Enable is a building automation interface point used to limit DX cooling capacity of the equipment, it does not limit economizer cooling. The 0-100% value limits the amount of cooling capacity.

### Heat Primary Enable

Primary Heat Enable is a building automation interface point used to limit all forms of primary heat installed in the equipment. The 0-100% value limits the amount of heating capacity.

### Demand Limit

Demand Limit is a function with building automation interface points used to limit power consumption of both heating and cooling capacities installed in the equipment. Demand Limit does not apply to economizer cooling, gas heat, external heat nor hot gas reheat.

Demand Limit Request BAS enables and disables the demand limit function. When set to Limit, the Demand Limit Setpoint value (0-100%) is applied to the control capacity calculation. The power consumption result will depend on number of heating and cooling stages installed and how each stage maps to the capacity calculation (0-100%).

### Filter Status

Filter status is provided by differential pressure monitoring across individual filters in the equipment airflow and trigger a binary output when the filter setpoint is achieved. The following setpoints are available if corresponding filter is installed:

- Final Filter Diff Press Setpoint, 0.5 – 6.0 IWC (4.0 IWC default)
- Pre Evap Filter Diff Press Setpoint, 0.5 – 6.0 IWC (4.0 IWC default)
- Energy Wheel Filter Diff Press Setpoint, 0.5 – 6.0 IWC (4.0 IWC default)

This is in the form of an analog signal to the Symbio controller which represents pressure drop. Monitoring is available for individual filters installed in the unit. The customer can monitor filter differential pressure for the purpose of filter maintenance. If an alarm is not desirable, the setpoint can be set to 6.0 IWC which is above the pressure transducers range. No manual calibration is necessary as the transducers are factory calibrated.

## Startup the Unit

Use the following in conjunction with the “[Trane Startup Checklist](#),” p. 166, to ensure that the unit is properly installed and ready for operation. Be sure to complete all of the procedures described in this section before starting the unit for the first time.



## Unit Startup

### **⚠ WARNING**

#### **Hazardous Voltage!**

**Failure to disconnect power before servicing could result in death or serious injury.**

**Disconnect all electric power, including remote disconnects before servicing. Follow proper lockout/tagout procedures to ensure the power can not be inadvertently energized. Verify that no power is present with a voltmeter.**

- Turn the field supplied disconnect switch, located upstream of the rooftop unit, to the “Off” position.
- Turn the 115 volt control circuit switch 1S2 to the “Off” position. .
- Turn the 24 volt control circuit switch 1S3 to the “Off” position. It is located in the secondary of the 1T2 - 1T5 transformers.
- Turn the “System” selection switch (at the Remote Panel) to the “Off” position and the “Fan” selection switch (if Applicable) to the “Auto” or “Off” position.
- Check all electrical connections for tightness and “point of termination” accuracy.
- Verify that the condenser airflow will be unobstructed.
- Check the compressor crankcase oil level. Oil should be visible in the compressor oil sight glass. The oil level should be 1/2 to 3/4 high in the sight glass with the compressor “Off”.
- Verify that all refrigerant service valves are back seated on each circuit.

### **NOTICE**

#### **Compressor Damage!**

**Excessive liquid accumulation in the suction lines could result in compressor damage.**

**Do not allow liquid refrigerant to enter the suction line.**

Do not start the unit in the cooling mode if the ambient temperature is below the following minimum recommended operating temperature:

Standard unit with or without HGBP — +45°F

**Note:** See for minimum outside air temperature.

- Check the supply fan belts for proper tension and the fan bearings for sufficient lubrication. If the belts require adjustment, or if the bearings need lubricating, refer to the Service/Maintenance section of this manual for instructions.
- Inspect the interior of the unit for tools and debris. Install all panels in preparation for starting the unit.

### **Electrical Phasing**

Scroll compressors are phase sensitive. Proper phasing of the electrical supply to the unit is critical for proper operation and reliability. The compressor motor is internally

connected for clockwise rotation with the incoming power supply phased as A, B, C.

Proper electrical supply phasing can be quickly determined and corrected before starting the unit by using an instrument such as an Associated Research Model 45 Phase Sequence Indicator and following the steps below:

### **⚠ WARNING**

#### **Hazardous Voltage!**

**Failure to disconnect power before servicing could result in death or serious injury.**

**Disconnect all electric power, including remote disconnects before servicing. Follow proper lockout/tagout procedures to ensure the power can not be inadvertently energized. Verify that no power is present with a voltmeter.**

**Important: HIGH VOLTAGE IS PRESENT AT TERMINAL BLOCK OR UNIT DISCONNECT SWITCH.**

- Turn the field supplied disconnect switch that provides power to terminal block or to the unit-mounted disconnect switch to the “Off” position.
- Connect the phase sequence indicator leads to the terminal block or unit-mounted disconnect switch as follows:

Phase Sequence Leads	Unit Power Terminal
Black (phase A)	L1
Red (phase B)	L2
Yellow (phase C)	L3

- Close the disconnect switch or circuit protector switch that provides the supply power to the unit terminal block or the unit mounted disconnect switch.
- Observe the ABC and CBA phase indicator lights on the face of the sequencer. The ABC indicator light will glow if the phase is ABC. If the CBA indicator light glows, open the disconnect switch or circuit protection switch and reverse any two power wires.
- Restore the main electrical power and recheck the phasing. If the phasing is correct, open the disconnect switch or circuit protection switch and remove the phase sequence indicator.

### **Voltage Supply**

Electrical power to the unit must meet stringent requirements for the unit to operate properly. Measure each leg (phase-to-phase) of the power supply. Each reading must fall within the utilization range stamped on the unit nameplate. If any of the readings do not fall within the proper tolerances, notify the power company to correct this situation before operating the unit.

## ⚠ WARNING

### Live Electrical Components!

Failure to follow all electrical safety precautions when exposed to live electrical components could result in death or serious injury.

When it is necessary to work with live electrical components, have a qualified licensed electrician or other individual who has been properly trained in handling live electrical components perform these tasks.

### Voltage Imbalance

Excessive three phase voltage imbalance between phases will cause motors to overheat and eventually fail. The maximum allowable voltage imbalance is 2 percent. Measure and record the voltage between phases 1, 2, and 3 and calculate the amount of imbalance as follows:

percent Voltage Imbalance =

$$100 \times \frac{AV - VD}{AV}$$

where;

AV (Average Voltage) =

$$\frac{Volt1 + Volt2 + Volt3}{3}$$

V1, V2, V3 = Line Voltage Readings

VD = Line Voltage reading that deviates the farthest from the average voltage.

**Example:** If the voltage readings of the supply power measured 221, 230, and 227, the average volts would be:

$$\frac{221 + 230 + 227}{3} = 226 \text{ Avg}$$

VD (reading farthest from average) = 221

The percentage of Imbalance equals:

$$100 \times \frac{226 - 221}{226} = 2.2\%$$

The 2.2% imbalance in this example exceeds the maximum allowable imbalance of 2.0%. This much imbalance between phases can equal as much as a 20% current imbalance with a resulting increase in motor winding temperatures that will decrease motor life. If the voltage imbalance is over 2%, notify the proper agencies to correct the voltage problem before operating this equipment.

## Verifying Proper Fan Operation

## ⚠ WARNING

### Hazardous Service Procedures!

Failure to follow all precautions in this manual and on the tags, stickers, and labels could result in death or serious injury.

Technicians, in order to protect themselves from potential electrical, mechanical, and chemical hazards, **MUST** follow precautions in this manual and on the tags, stickers, and labels, as well as the following instructions: **Unless specified otherwise, disconnect all electrical power including remote disconnect and discharge all energy storing devices such as capacitors before servicing. Follow proper lockout/tagout procedures to ensure the power can not be inadvertently energized. When necessary to work with live electrical components, have a qualified licensed electrician or other individual who has been trained in handling live electrical components perform these tasks.**

1. Close the disconnect switch or circuit protector switch that provides the supply power to the unit terminal block 2XD1 or the unit mounted disconnect switch 2QB1.
2. Turn the 115 volt control fused disconnect circuit switch to the On position.

## ⚠ WARNING

### Rotating Components!

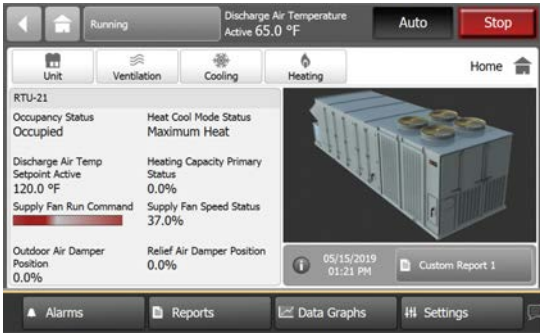
Failure to disconnect power before servicing could result in rotating components cutting and slashing technician which could result in death or serious injury.

During installation, testing, servicing and troubleshooting of this product it may be necessary to work with live and exposed rotating components. **Have a qualified or licensed service individual who has been properly trained in handling exposed rotating components, perform these tasks.**

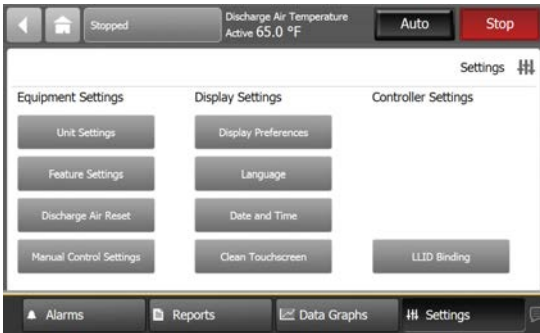
3. Press the Stop button on the user interface. To setup and troubleshoot supply fan operation, navigate to Supply Fan Manual Override by following the steps provided below.

**Note:** *The unit's design supply airflow is established when the supply fan is operating at 100% speed command. If the design supply airflow rating of the unit needs to be modified, the new maximum design speed must be set at the supply fan's variable frequency drive (VFD) key pad. The user should identify the maximum speed for the supply fan wheels and ensure those speeds are not exceeded when making entries at the VFD key pads.*

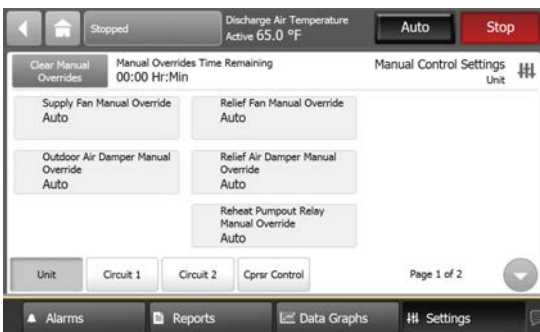
- a. Press Stop and then touch Settings.



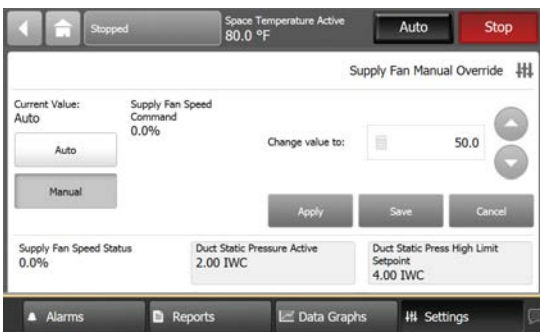
b. Touch Manual Control Settings in the Settings screen.



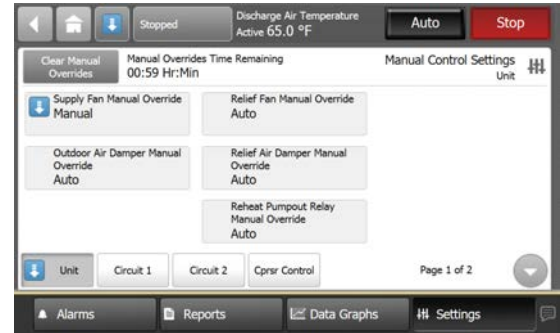
c. Touch Supply Fan Manual Override in the Manual Control Settings screen.



d. Touch Manual, then touch Change value to: to adjust the speed setting, press Enter, then press Apply.



e. When done testing, touch Clear All Manual Overrides or select the individual override and press Auto.

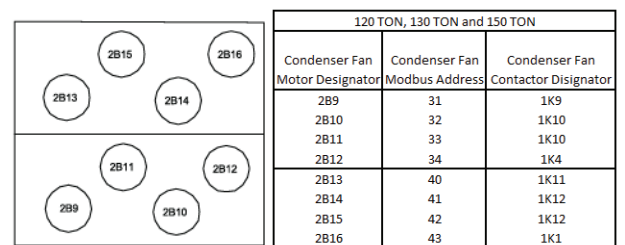
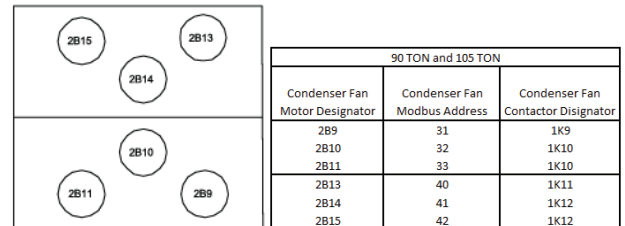


4. The above procedure can be followed for testing and setup of relief fans and condenser fans.

**Note:** Changes to the unit's design relief airflow rating is modified at the user interface by adjusting the Relief Fan Maximum Speed Setpoint located under the Service Settings menu.

Check all fans for proper rotation. Supply Fan rotation is indicated by an arrow located on the fan housing (clockwise from motor side of fan). Relief Fan rotation is counter-clockwise when viewed from the motor side of the fan assembly. Condenser Fan rotation is clockwise when viewed from the top.

**Figure 42. 90-150 tons condenser fan locations**



**If all of the fans are rotating backwards:**

1. Press the STOP key on the user interface in the unit control panel to stop the fan operation.
2. Open the field-supplied disconnect switch upstream of the rooftop unit. Lock the disconnect switch in the open position while working at the unit.

**⚠ WARNING**

**Hazardous Voltage!**

Failure to disconnect power before servicing could result in death or serious injury.

Disconnect all electric power, including remote disconnects before servicing. Follow proper lockout/tagout procedures to ensure the power can not be inadvertently energized. Verify that no power is present with a voltmeter.

- Interchange any two of the field connected main power wires at the unit terminal block or the factory mounted disconnect switch.

**Note:** Interchanging “Load” side power wires at the fan contactors will only affect the individual fan rotation. Ensure that the voltage phase sequence at the main terminal block or the factory mounted disconnect switch is ABC as outlined in the “Unit Startup\_Electrical Phasing,” p. 92 section.

**System Airflow Measurements**

**Variable Air Volume Systems**

- Ensure that the “System” selection switch at the remote panel is in the Off position.
- Close the disconnect switch or circuit protector switch that provides the supply power to the unit terminal block or the unit mounted disconnect switch.

**⚠ WARNING**

**Hazardous Voltage!**

Failure to disconnect power before servicing could result in death or serious injury.

Disconnect all electric power, including remote disconnects before servicing. Follow proper lockout/tagout procedures to ensure the power can not be inadvertently energized. Verify that no power is present with a voltmeter.

**Important:** HIGH VOLTAGE IS PRESENT AT TERMINAL BLOCK OR UNIT DISCONNECT SWITCH.

- Turn the 115 volt control circuit switch and the 24 volt control circuit switch to the On position.
- Navigate to Supply Fan Manual Overrides. The supply fan speed will be adjusted through the user interface. With the unit in Stop, tap the Manual Override button for the Supply Fan. Set the Fan Speed to 100%.

**⚠ WARNING**

**Live Electrical Components!**

Failure to follow all electrical safety precautions when exposed to live electrical components could result in death or serious injury.

When it is necessary to work with live electrical components, have a qualified licensed electrician or other individual who has been properly trained in handling live electrical components perform these tasks.

- With the VFD at 100% and the supply fan operating at full airflow capability, measure the amperage at the supply fan contactors. If the amperage exceeds the motor nameplate value, the static pressure is less than design and the airflow is too high. If the amperage is below the motor nameplate value, static pressure may be too high and CFM may be too low. To determine the **actual CFM** (± 5%):

- Measure the actual fan RPM

- $$\frac{\text{Actual Motor Amps}}{\text{Motor Nameplate Amps}} \times \text{Motor HP}$$

- Plot this data onto the appropriate Fan Performance Curve (see Performance Data). Where the two points intersect, read straight down to the CFM line. Use this data to assist in calculating a new fan drive if the CFM is not at design specifications.

- An alternate method with less accuracy is to measure the static pressure drop across the evaporator coil. This can be accomplished by completing the following steps:

- Drill a small hole through the unit casing on each side of the coil.

**Important:** Coil damage can occur if care is not taken when drilling holes in this area.

- Measure the difference between the pressures at both locations.
- Plot this value onto the appropriate pressure drop curve (see Fan Performance Data). Use the data in Component Static Pressure Drops to assist in calculating a new fan drive if the CFM is not at design specifications.
- Plug the holes after the proper CFM has been established.

- Press the STOP key at the user interface in the unit control panel to stop the fan operation.



### Exhaust Airflow Measurement (Optional)

**⚠ WARNING**

**Hazardous Voltage!**  
 Failure to disconnect power before servicing could result in death or serious injury.  
 Disconnect all electric power, including remote disconnects before servicing. Follow proper lockout/tagout procedures to ensure the power can not be inadvertently energized. Verify that no power is present with a voltmeter.

**Important:** HIGH VOLTAGE IS PRESENT AT TERMINAL BLOCK OR UNIT DISCONNECT SWITCH.

1. Close the disconnect switch or circuit protector switch that provides the supply power to the unit's terminal block or the unit mounted disconnect switch.
2. Turn the 115 volt control circuit switch and the 24 volt control circuit switch to the "On" position.
3. Navigate to Relief Fan Manual Overrides. The Relief fan speed will be adjusted through the user interface. With the unit in Stop, tap Manual Override for the Relief Fan. Set the Fan Speed to 100%..

**⚠ WARNING**

**Live Electrical Components!**  
 Failure to follow all electrical safety precautions when exposed to live electrical components could result in death or serious injury.  
 When it is necessary to work with live electrical components, have a qualified licensed electrician or other individual who has been properly trained in handling live electrical components perform these tasks.

4. With the exhaust dampers open and the exhaust fan operating at full airflow capability, measure the amperage at the exhaust fan contactor. If the amperage exceeds the motor nameplate value, the static pressure

is less than design and airflow is too high. If the amperage is below the motor nameplate value, static pressure may be too high and CFM may be too low.

To determine the **actual CFM** (± 5%):

- a. Measure the actual fan RPM
  - b. Calculate the Theoretical BHP:  

$$\frac{\text{Actual Motor Amps}}{\text{Motor Nameplate Amps}} \times \text{Motor HP}$$
  - c. Use "Relief Fan," p. 101 to calculate a new fan drive if the CFM is not at design specifications.
5. Press the STOP key on the user interface in the unit control panel to stop the fan operation.

### Traq™ Sensor Airflow Measurement (Optional with all units equipped with an economizer)

1. Use to program the following system components for Economizer operation by scrolling through the displays;
  - Supply Fan (On)
  - Outside air dampers (Selected % Open)
  - Variable Frequency Drive (100% Output, if applicable)
  - Outside Air CFM Setpoint
  - Outside Air Pre-Heater Operation (if applicable)
2. Navigate to Supply Fan Manual Overrides. The supply fan speed will be adjusted through the user interface. With the unit in Stop, touch the Manual Override button for the Supply Fan. Set the Fan Speed to 100%.
3. With the unit operating in the "Manual Override", the amount of outside air flowing through the Traq™ sensor can be viewed.
4. Navigate to the "ECONOMIZER POSITION" and read the corresponding damper opening percentage (%).



# Performance Data

## Supply Fan

Figure 43. Supply fan performance LOW CFM (25")

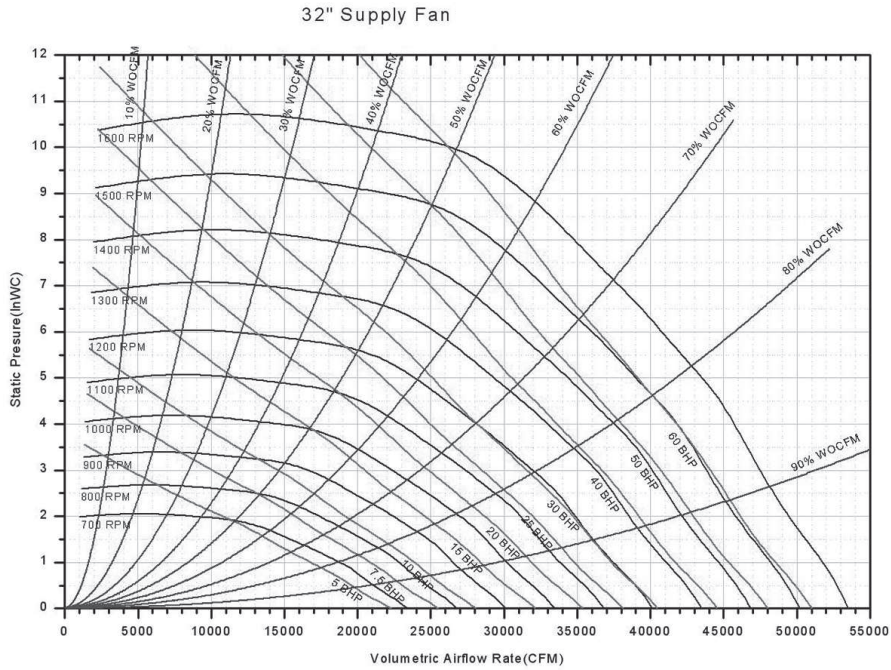
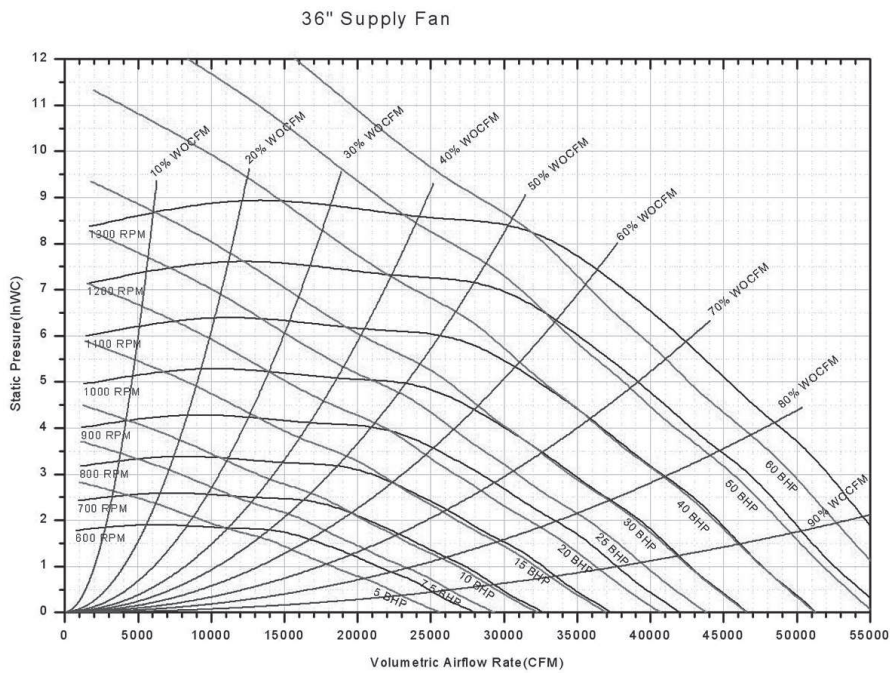


Figure 44. Supply fan performance STANDARD CFM (36")- 90-105 tons





# Unit Startup

Figure 45. Supply fan performance LOW CFM (32")

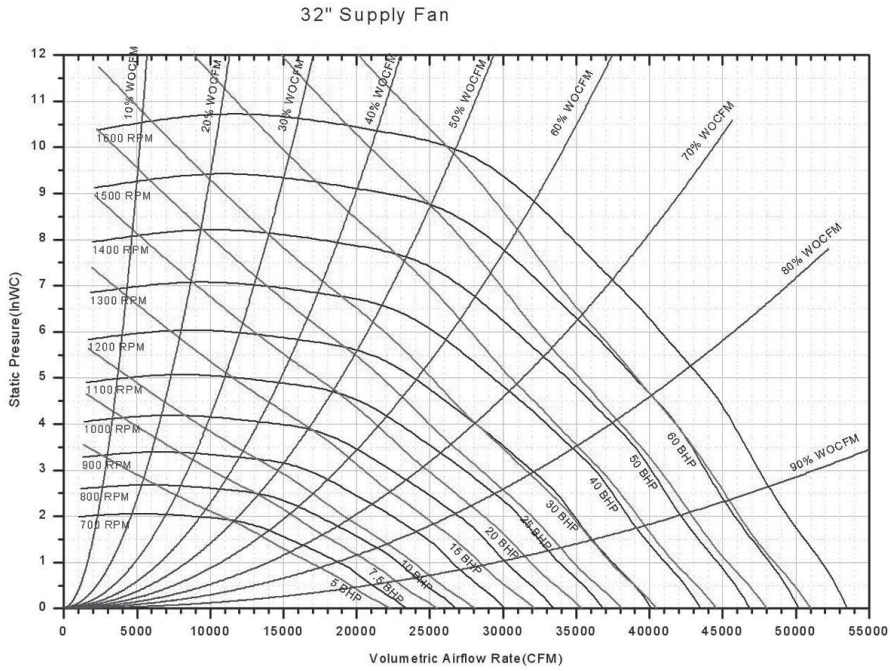
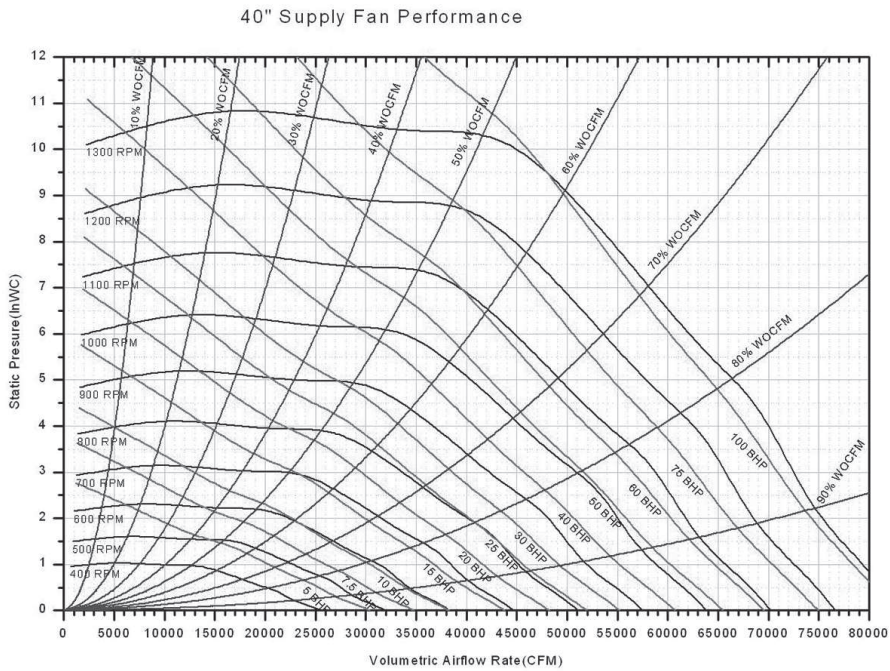
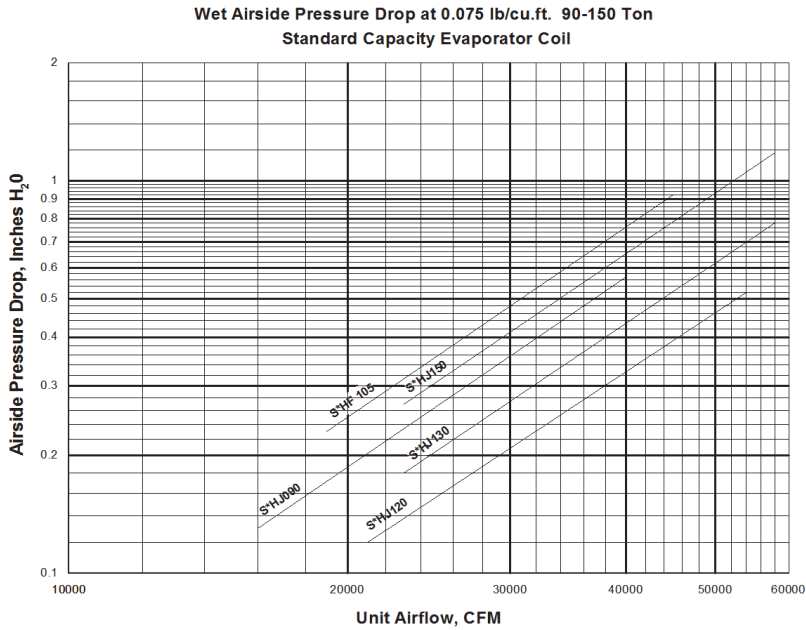


Figure 46. Supply fan performance STANDARD CFM - 120-150 tons (40")

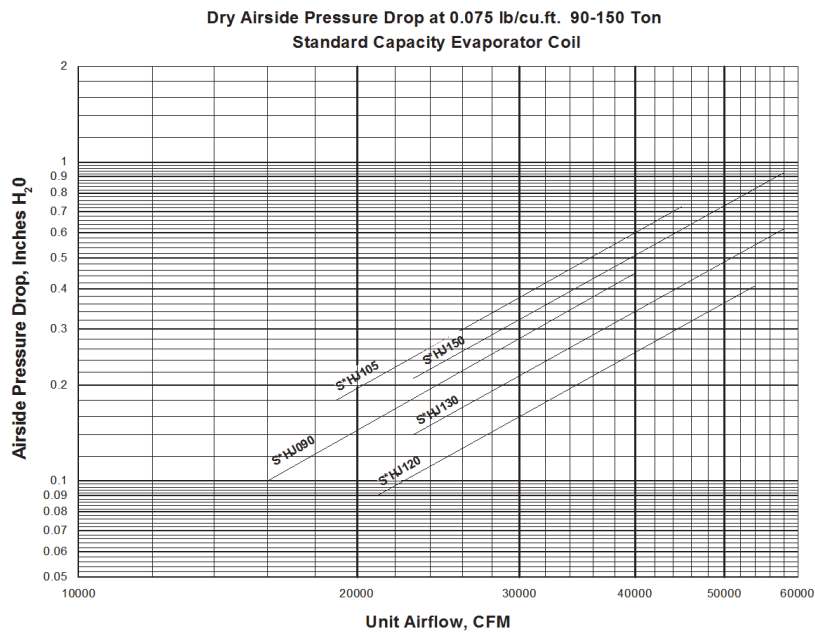


## Airside Pressure Drop — Standard Evaporator Coil

**Figure 47. Wet airside pressure drop at 0.075 lb./cu. ft.— 90-150 tons standard evaporator coil**



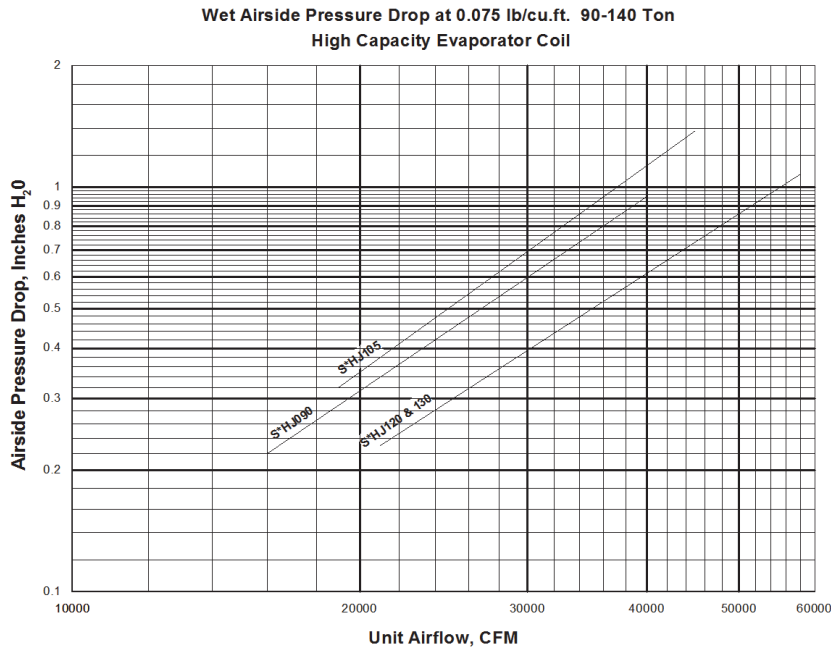
**Figure 48. Dry airside pressure drop at 0.075 lb./cu. ft.— 90-150 tons standard capacity evaporator coil**



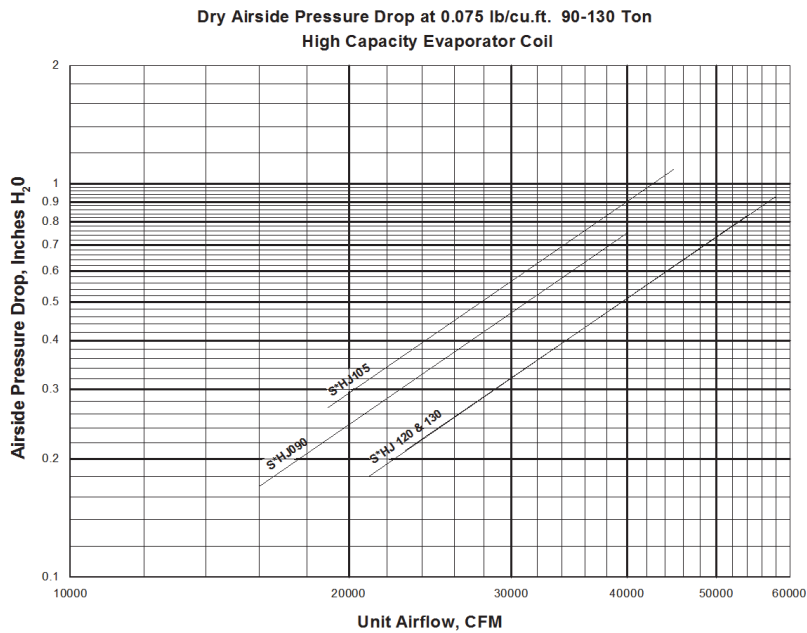


# Unit Startup

**Figure 49. Wet airside pressure drop at 0.075 lb./cu. ft.— 90-130 tons high capacity evaporator coil**



**Figure 50. Dry airside pressure drop at 0.075 lb./cu. ft.—90-130 tons high capacity evaporator coil**



## Relief Fan

Figure 51. Relief fan performance LOW CFM - 90 tons (25" Fan)

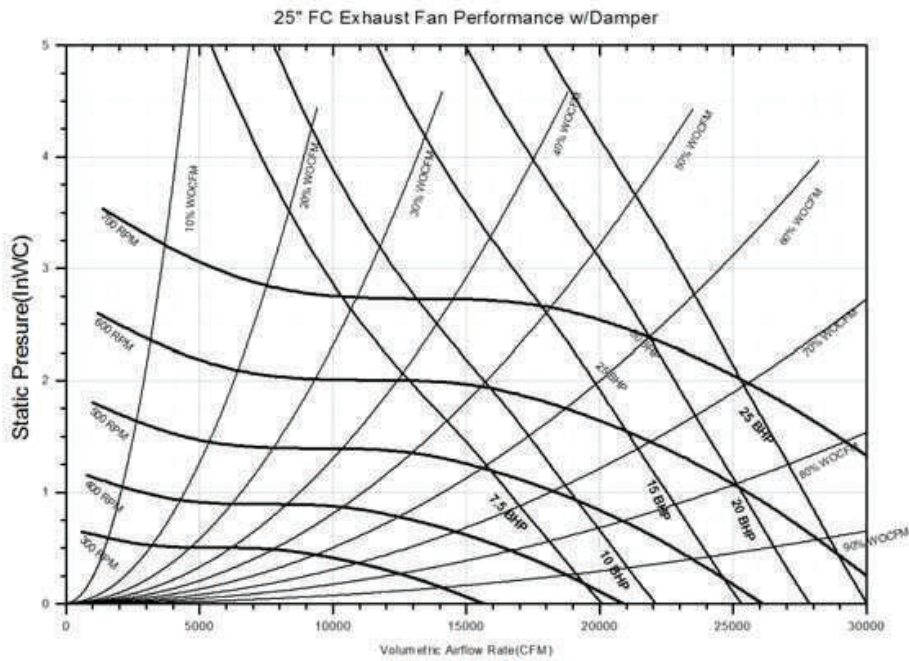
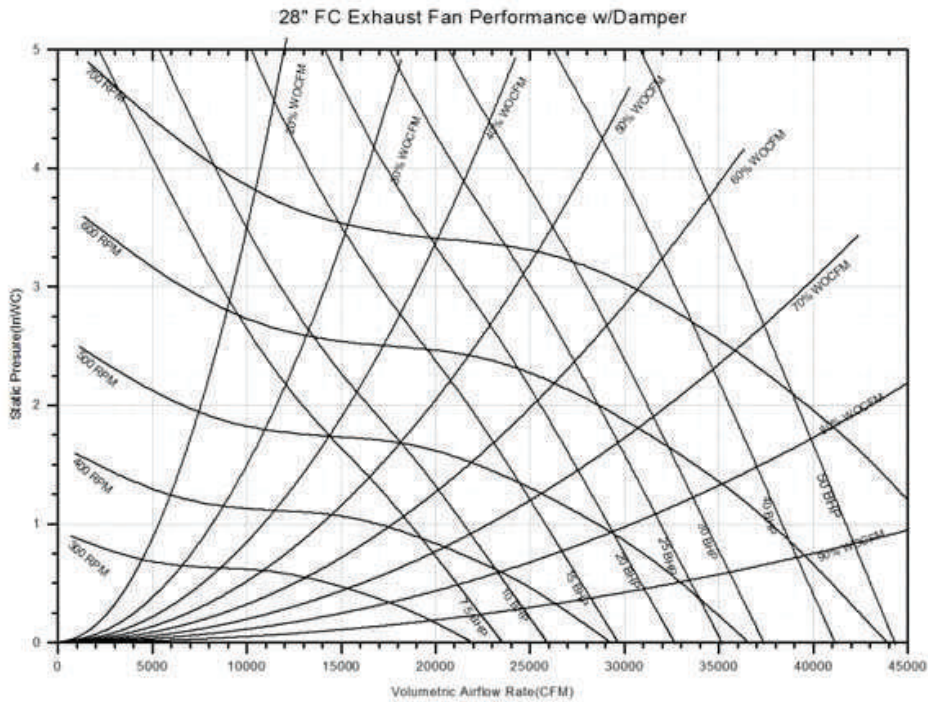


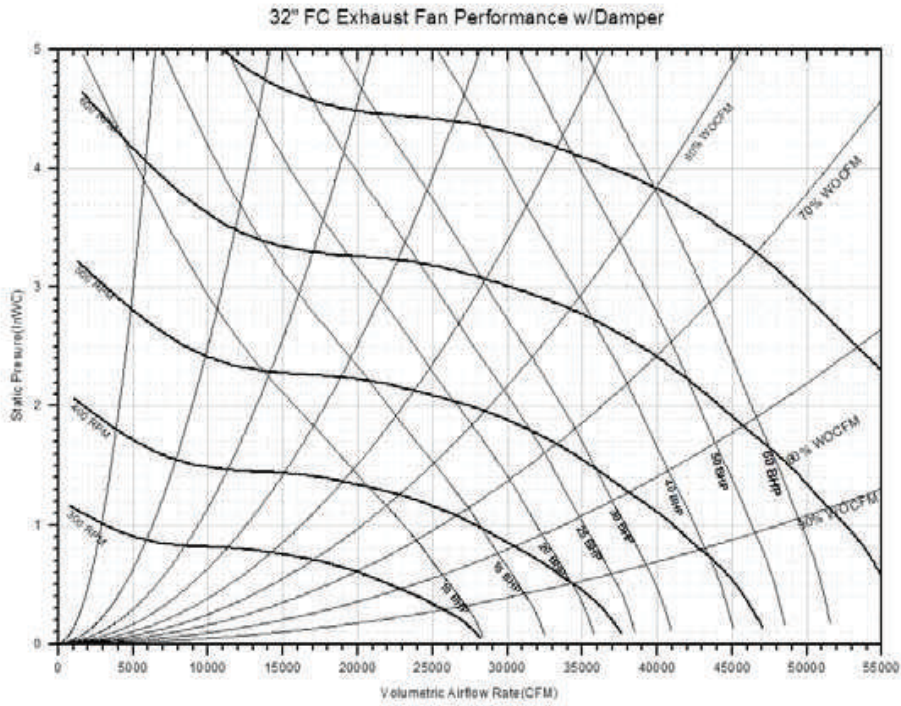
Figure 52. Relief fan performance STANDARD CFM—90 tons; LOW CFM—105-150 tons (28")





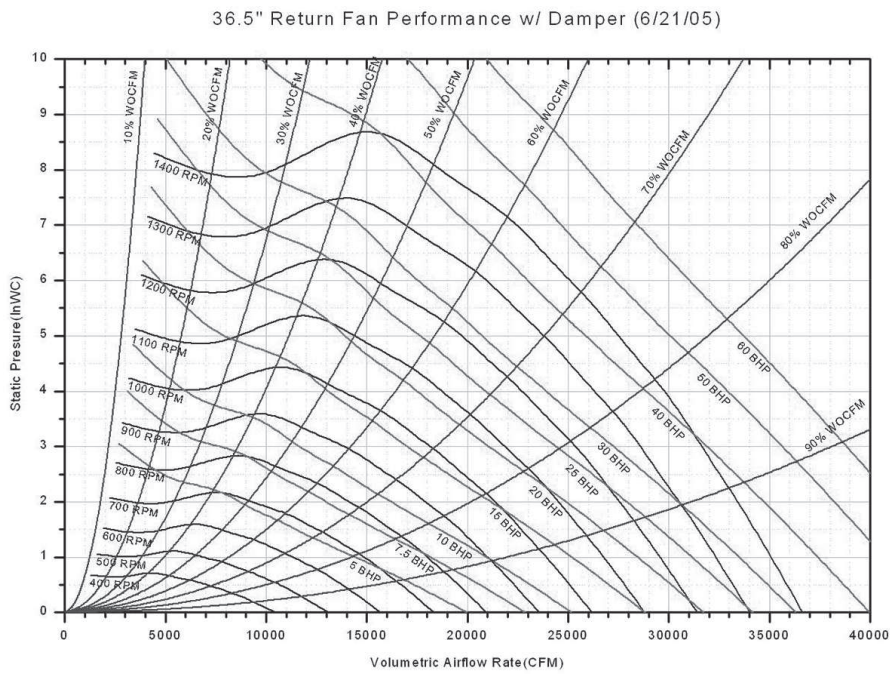
## Unit Startup

Figure 53. Relief fan performance standard CFM —105-150 tons (32")

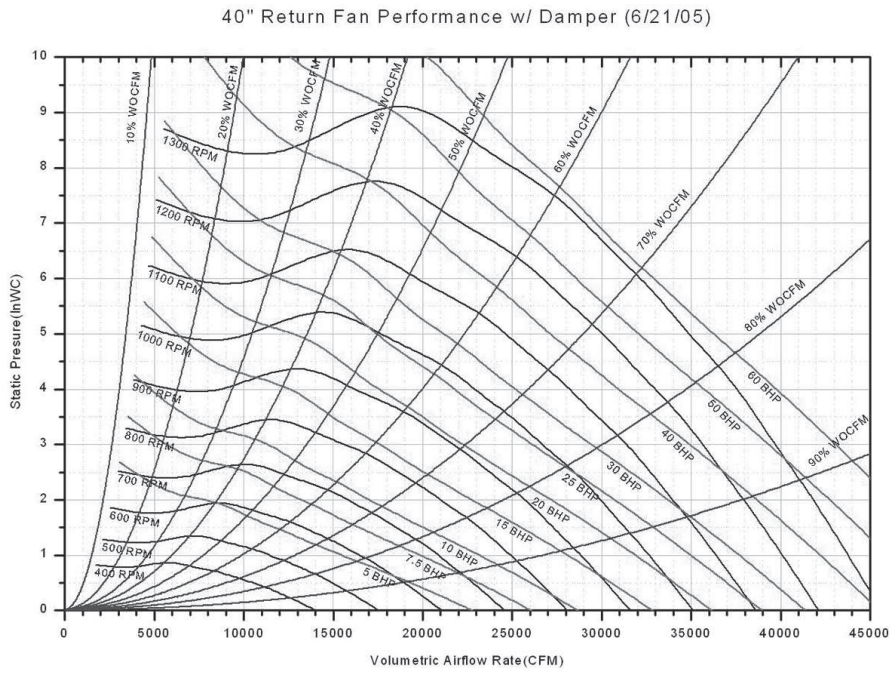


## Return Fan

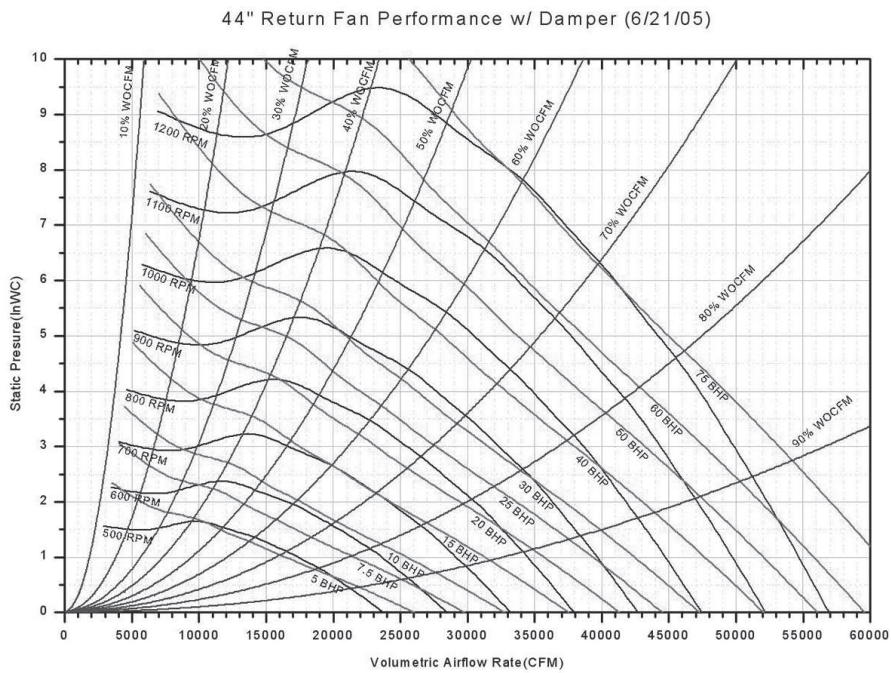
Figure 54. Return fan performance LOW CFM 90-150 tons (36.5")



**Figure 55. Return fan performance STANDARD CFM - 90-105 tons (40")**



**Figure 56. Return fan performance STANDARD CFM—120-150 tons (44")**





## Unit Startup

### Component Static Pressure Drops

Table 45. Component static pressure drops (in. H<sub>2</sub>O)

Nom Tons	CFM	Evaporator Coil					(Dampers wide open)			
		Standard		High Capacity		Reheat Coil	Return Damper	Outside Air <sup>(a)</sup>		
		Dry	Wet	Dry	Wet	Dry		Econo Damper	Traq Damper	
90	16000	0.1	0.13	0.17	0.22	0.04	0.06	0.11	0.19	
	20000	0.15	0.19	0.24	0.31	0.06	0.1	0.17	0.29	
	25000	0.21	0.27	0.35	0.45	0.08	0.16	0.27	0.45	
	30000	0.28	0.36	0.47	0.6	0.11	0.23	0.39	0.65	
	33000	0.33	0.42	0.55	0.7	0.13	0.28	0.47	0.79	
	36000	0.38	0.48	0.63	0.8	0.15	0.34	0.57	0.94	
	40000	0.45	0.57	0.75	0.95	0.18	0.42	0.7	1.16	
105	19000	0.18	0.23	0.27	0.32	0.05	0.09	0.15	0.26	
	23000	0.2	0.31	0.37	0.47	0.07	0.13	0.23	0.38	
	28000	0.34	0.43	0.51	0.64	0.1	0.2	0.34	0.57	
	33000	0.44	0.56	0.66	0.84	0.13	0.28	0.47	0.79	
	38000	0.55	0.7	0.83	1.05	0.16	0.38	0.63	1.05	
	43000	0.67	0.85	1.01	1.28	0.2	0.49	0.81	1.34	
	45000	0.73	0.92	1.09	1.38	0.21	0.53	0.89	1.47	
120	21000	0.11	0.14	0.18	0.23	0.04	0.05	0.1	0.17	
	26000	0.17	0.22	0.25	0.32	0.06	0.09	0.15	0.26	
	31000	0.23	0.29	0.34	0.43	0.08	0.12	0.22	0.36	
	36000	0.29	0.38	0.43	0.55	0.1	0.17	0.3	0.49	
	41000	0.36	0.45	0.53	0.67	0.12	0.22	0.39	0.64	
	46000	0.44	0.55	0.64	0.81	0.15	0.28	0.49	0.8	
	54000	0.51	0.64	0.75	0.95	0.18	0.35	0.61	0.99	
130	23000	0.14	0.18	0.21	0.27	0.05	0.07	0.12	0.2	
	26000	0.17	0.22	0.25	0.32	0.06	0.09	0.15	0.26	
	30000	0.21	0.27	0.32	0.41	0.07	0.12	0.21	0.34	
	35000	0.27	0.35	0.41	0.52	0.1	0.16	0.28	0.46	
	40000	0.34	0.43	0.51	0.65	0.12	0.21	0.37	0.61	
	45000	0.41	0.52	0.61	0.78	0.15	0.27	0.47	0.77	
	50000	0.49	0.62	0.73	0.93	0.17	0.33	0.59	0.95	
	58000	0.57	0.72	0.85	1.08	0.2	0.4	0.71	1.15	
150	23000	0.21	0.27	-	-	0.05	0.07	0.12	0.2	
	26000	0.25	0.32	-	-	0.06	0.09	0.15	0.26	
	30000	0.32	0.41	-	-	0.07	0.12	0.21	0.34	
	35000	0.41	0.52	-	-	0.1	0.16	0.28	0.46	
	40000	0.51	0.65	-	-	0.12	0.21	0.37	0.61	
	45000	0.61	0.78	-	-	0.15	0.27	0.47	0.77	
	50000	0.73	0.93	-	-	0.17	0.33	0.59	0.95	
	58000	0.85	1.08	-	-	0.2	0.4	0.71	1.15	

**Note:** Actual Supply Fan CFM Range: 90 Ton 16000-40000; 105 Ton 19000-45000; 120 Ton 21000-54000; 130-150 Ton 23000-58000

<sup>(a)</sup> Use only 1 value. Select Traq value if option is selected.



**Table 46. Component static pressure drops (in. H<sub>2</sub>O)**

Nom Tons	CFM	Electric Heating (Hz) All kW's	Gas Heating						Hydronic Heating Coil Data			
			Low Heat		Medium Heat		High Heat		Hot Water Coil		Steam Coil	
			DF	Hz	DF	Hz	DF	Hz	High	Low	High	Low
90	16000	0.01	0.01	0.02	0.01	0.04	0.03	0.07	0.13	0.08	0.12	0.08
	20000	0.02	0.01	0.04	0.01	0.07	0.04	0.12	0.19	0.12	0.17	0.12
	25000	0.03	0.02	0.05	0.02	0.11	0.07	0.18	0.27	0.17	0.26	0.18
	30000	0.05	0.03	0.06	0.03	0.15	0.10	0.26	0.36	0.24	0.35	0.25
	33000	0.06	0.04	0.07	0.04	0.18	0.12	0.32	0.42	0.28	0.41	0.3
	36000	0.07	0.04	0.10	0.04	0.22	0.14	0.38	0.49	0.33	0.48	0.35
	40000	0.08	0.06	0.12	0.06	0.27	0.18	0.47	0.58	0.39	0.57	0.43
105	19000	0.02	0.01	0.03	0.01	0.06	0.04	0.11	0.17	0.11	0.16	0.11
	23000	0.03	0.02	0.04	0.02	0.09	0.06	0.15	0.23	0.15	0.22	0.16
	28000	0.04	0.03	0.06	0.03	0.13	0.09	0.23	0.32	0.21	0.31	0.22
	33000	0.06	0.04	0.07	0.04	0.18	0.12	0.32	0.42	0.28	0.41	0.3
	38000	0.07	0.05	0.10	0.05	0.24	0.16	0.42	0.53	0.36	0.52	0.39
	43000	0.1	0.06	0.14	0.06	0.31	0.20	0.54	0.65	0.45	0.65	0.49
	45000	0.1	0.07	0.15	0.07	0.34	0.22	0.59	0.71	0.49	0.7	0.53
120	21000	0.02	0.02	0.07	0.05	0.13	0.08	0.18	0.14	0.09	0.13	0.09
	26000	0.03	0.02	0.11	0.07	0.20	0.13	0.28	0.2	0.13	0.19	0.13
	31000	0.05	0.03	0.16	0.11	0.28	0.18	0.40	0.26	0.17	0.25	0.18
	36000	0.07	0.04	0.22	0.14	0.38	0.24	0.54	0.33	0.22	0.33	0.24
	41000	0.09	0.06	0.28	0.19	0.49	0.31	0.70	0.42	0.28	0.41	0.3
	46000	0.11	0.07	0.36	0.23	0.62	0.39	0.88	0.5	0.34	0.5	0.37
	51000	0.13	0.09	0.44	0.29	0.76	0.48	1.08	0.6	0.41	0.59	0.44
	54000	0.15	0.10	0.49	0.32	0.85	0.54	1.21	0.66	0.45	0.65	0.49
130	23000	0.03	0.02	0.09	0.06	0.15	0.10	0.22	0.16	0.1	0.15	0.1
	26000	0.03	0.02	0.11	0.07	0.20	0.13	0.28	0.2	0.13	0.19	0.13
	30000	0.05	0.03	0.15	0.10	0.26	0.17	0.37	0.25	0.16	0.24	0.17
	35000	0.06	0.04	0.21	0.14	0.36	0.23	0.51	0.32	0.21	0.31	0.22
	40000	0.08	0.06	0.27	0.18	0.47	0.30	0.66	0.4	0.27	0.39	0.28
	45000	0.1	0.07	0.34	0.22	0.59	0.38	0.84	0.49	0.33	0.48	0.35
	50000	0.13	0.09	0.42	0.28	0.73	0.46	1.03	0.58	0.39	0.57	0.43
	55000	0.16	0.10	0.51	0.33	0.88	0.56	1.25	0.68	0.47	0.67	0.51
	58000	0.17	0.12	0.57	0.37	0.98	0.63	1.39	0.75	0.51	0.74	0.56
150	23000	0.03	0.02	0.09	0.06	0.15	0.10	0.22	0.16	0.1	0.15	0.1
	26000	0.03	0.02	0.11	0.07	0.20	0.13	0.28	0.2	0.13	0.19	0.13
	30000	0.05	0.03	0.15	0.10	0.26	0.17	0.37	0.25	0.16	0.24	0.17
	35000	0.06	0.04	0.21	0.14	0.36	0.23	0.51	0.32	0.21	0.31	0.22
	40000	0.08	0.06	0.27	0.18	0.47	0.30	0.66	0.4	0.27	0.39	0.28
	45000	0.1	0.07	0.34	0.22	0.59	0.38	0.84	0.49	0.33	0.48	0.35
	50000	0.13	0.09	0.42	0.28	0.73	0.46	1.03	0.58	0.39	0.57	0.43
	55000	0.16	0.10	0.51	0.33	0.88	0.56	1.25	0.68	0.47	0.67	0.51
	58000	0.17	0.12	0.57	0.37	0.98	0.63	1.39	0.75	0.51	0.74	0.56

**Note:** There is no pressure drop with electric heat DF configuration



## Unit Startup

**Table 47. Energy recovery wheel component static pressure drops — low CFM**

Nom Tons	CFM	Outside Air Bypass Damper Open	Outside Air Bypass Damper Closed	Relief Air Bypass Damper Open	Relief Air Bypass Damper Closed
<b>Low CFM Energy Recovery Wheel</b>					
90	8000	0.07	0.78	0.09	0.66
	9000	0.09	0.88	0.11	0.79
	10000	0.12	0.99	0.14	0.92
	12000	0.16	1.20	0.19	1.16
	14000	0.21	1.42	0.24	1.41
	16000	0.27	—	0.29	—
	20000	0.40	—	0.42	—
	25000	0.59	—	0.60	—
	30000	0.80	—	0.80	—
	33000	0.94	—	0.94	—
	36000	1.08	—	1.07	—
	40000	1.30	—	1.27	—
105	9000	0.09	0.88	0.11	0.79
	12000	0.16	1.20	0.19	1.16
	14000	0.21	1.42	0.24	1.41
	16000	0.27	—	0.29	—
	19000	0.36	—	0.39	—
	23000	0.51	—	0.52	—
	28000	0.71	—	0.72	—
	33000	0.94	—	0.94	—
	38000	1.19	—	1.18	—
	43000	1.46	—	1.41	—
		45000	1.58	—	1.52
120	9000	0.09	0.78	0.11	0.69
	12000	0.16	1.06	0.18	1.02
	15000	0.23	1.36	0.26	1.36
	18000	0.31	—	0.34	—
	21000	0.41	—	0.44	—
	26000	0.59	—	0.62	—
	31000	0.79	—	0.82	—
	36000	1.01	—	1.04	—
	41000	1.25	—	1.28	—
	46000	1.51	—	1.52	—
		51000	1.79	—	1.79
	54000	1.96	—	1.95	—
130	9000	0.09	0.71	0.10	0.62
	12000	0.15	0.97	0.18	0.92
	16000	0.25	1.34	0.28	1.33
	20000	0.36	—	0.40	—
	23000	0.46	—	0.49	—
	26000	0.57	—	0.60	—
	30000	0.72	—	0.75	—
	35000	0.93	—	0.97	—
	40000	1.16	—	1.20	—
	45000	1.40	—	1.43	—
	50000	1.67	—	1.69	—
	55000	1.95	—	1.96	—
		58000	2.12	—	2.12

**Table 47. Energy recovery wheel component static pressure drops — low CFM (continued)**

Nom Tons	CFM	Outside Air Bypass Damper Open	Outside Air Bypass Damper Closed	Relief Air Bypass Damper Open	Relief Air Bypass Damper Closed
<b>Low CFM Energy Recovery Wheel</b>					
150	9000	0.09	0.71	0.10	0.62
	12000	0.15	0.97	0.18	0.92
	16000	0.25	1.34	0.28	1.33
	20000	0.36	—	0.40	—
	23000	0.46	—	0.49	—
	26000	0.57	—	0.60	—
	30000	0.72	—	0.75	—
	35000	0.93	—	0.97	—
	40000	1.16	—	1.20	—
	45000	1.40	—	1.43	—
	50000	1.67	—	1.69	—
	55000	1.95	—	1.96	—
	58000	2.12	—	2.12	—

**Table 48. Energy recovery wheel component static pressure drops — standard CFM**

Nom Tons	CFM	Outside Air Bypass Damper Open	Outside Air Bypass Damper Closed	Relief Air Bypass Damper Open	Relief Air Bypass Damper Closed
<b>Standard CFM Energy Recovery Wheel</b>					
90	8000	0.06	0.54	0.07	0.44
	9000	0.08	0.61	0.10	0.53
	10000	0.10	0.68	0.12	0.62
	12000	0.15	0.83	0.17	0.77
	14000	0.19	0.99	0.22	0.94
	16000	0.24	1.16	0.26	1.12
	18000	0.30	1.32	0.31	1.29
	20000	0.35	-	0.37	-
	25000	0.52	-	0.54	-
	30000	0.70	-	0.73	-
	33000	0.82	-	0.84	-
	36000	0.95	-	0.97	-
	40000	1.12	-	1.14	-
105	9000	0.08	0.57	0.09	0.47
	12000	0.14	0.77	0.16	0.65
	14000	0.19	0.93	0.21	0.78
	16000	0.24	1.08	0.26	0.91
	19000	0.32	1.33	0.34	1.11
	21000	0.37	1.49	0.40	1.25
	23000	0.44	-	0.46	-
	28000	0.61	-	0.64	-
	33000	0.80	-	0.82	-
	38000	1.00	-	1.03	-
	43000	1.23	-	1.25	-
45000	1.33	-	1.34	-	



**Unit Startup**

**Table 48. Energy recovery wheel component static pressure drops — standard CFM (continued)**

Nom Tons	CFM	Outside Air Bypass Damper Open	Outside Air Bypass Damper Closed	Relief Air Bypass Damper Open	Relief Air Bypass Damper Closed
<b>Standard CFM Energy Recovery Wheel</b>					
120	10000	0.10	0.56	0.11	0.50
	12000	0.14	0.69	0.16	0.63
	15000	0.20	0.89	0.23	0.85
	18000	0.27	1.10	0.29	1.05
	21000	0.35	1.33	0.38	1.28
	24000	0.43	1.57	0.47	1.51
	26000	0.50	-	0.54	-
	31000	0.66	-	0.72	-
	36000	0.84	-	0.91	-
	41000	1.04	-	1.11	-
	46000	1.26	-	1.34	-
	51000	1.49	-	1.56	-
54000	1.63	-	1.71	-	
130-150	13000	0.16	0.59	0.17	0.53
	15000	0.20	0.69	0.22	0.63
	18000	0.26	0.86	0.28	0.79
	21000	0.33	1.04	0.36	0.96
	23000	0.38	1.16	0.42	1.06
	26000	0.45	1.36	0.50	1.24
	29000	0.54	1.57	0.60	1.42
	30000	0.57	-	0.63	-
	35000	0.72	-	0.80	-
	40000	0.89	-	0.98	-
	45000	1.08	-	1.17	-
	50000	1.28	-	1.38	-
	55000	1.50	-	1.60	-
	58000	1.63	-	1.74	-

**Table 49. Energy recovery wheel component static pressure drops — dampers**

Tons	CFM	Return Damper, ERW only	Econo Damper, ERW only
90	16000	0.14	0.15
	20000	0.2	0.24
	25000	0.29	0.39
	30000	0.42	0.56
	33000	0.51	0.69
	36000	0.61	0.82
	40000	0.75	1.01
105	19000	0.19	0.22
	23000	0.25	0.33
	28000	0.37	0.49
	33000	0.51	0.69
	38000	0.68	0.91
	43000	0.87	1.17
120	45000	0.96	1.29
	21000	0.22	0.18
	26000	0.32	0.27
	31000	0.45	0.39
	36000	0.61	0.53
	41000	0.79	0.69
	46000	1	0.87
51000	1.24	1.07	
54000	1.4	1.2	

**Table 49. Energy recovery wheel component static pressure drops — dampers (continued)**

Tons	CFM	Return Damper, ERW only	Econo Damper, ERW only
130-150	23000	0.25	0.21
	26000	0.32	0.27
	30000	0.42	0.36
	35000	0.57	0.5
	40000	0.75	0.65
	45000	0.96	0.83
	50000	1.19	1.02
	55000	1.45	1.24
	58000	1.63	1.38

**Table 50. Energy recovery wheel pressure loss  $\Delta P$  (in. wg) and total effectiveness**

Actual Airflow CFM	90-105 Tons Low		120 Tons Low		130-150 Tons Low		90 Tons Standard		105 Tons Standard		120 Tons Standard		130-150 Tons Standard	
	$\Delta P$	Eff	$\Delta P$	Eff	$\Delta P$	Eff	$\Delta P$	Eff	$\Delta P$	Eff	$\Delta P$	Eff	$\Delta P$	Eff
8000	0.73	77.50	0.64	79.00	0.58	80.00	0.49	81.60	—	—	—	—	—	—
9000	0.82	75.90	0.72	77.60	0.65	78.70	0.55	80.60	0.51	81.30	—	—	—	—
10000	0.91	74.30	0.80	76.20	0.73	77.50	0.61	79.50	0.56	80.30	0.49	81.60	—	—
11000	1.00	72.70	0.88	74.80	0.80	76.20	0.67	78.50	0.62	79.40	0.54	80.70	—	—
12000	1.09	71.10	0.96	73.40	0.87	75.00	0.73	77.40	0.67	78.40	0.59	79.80	—	—
13000	1.18	69.50	1.04	72.00	0.94	73.70	0.79	76.40	0.73	77.40	0.64	79.00	0.48	74.70
14000	—	—	1.12	70.60	1.02	72.40	0.85	75.30	0.79	76.50	0.69	78.10	0.51	72.90
15000	—	—	1.20	69.20	1.09	71.10	0.91	74.30	0.84	75.50	0.74	77.30	0.55	71.90
16000	—	—	—	—	1.16	69.80	0.97	73.20	0.90	74.50	0.79	76.40	0.58	71.00
17000	—	—	—	—	1.24	68.50	1.03	72.10	0.95	73.50	0.83	75.60	0.61	70.00
18000	—	—	—	—	—	—	1.09	71.10	1.01	72.50	0.88	74.70	0.64	69.00
19000	—	—	—	—	—	—	1.15	70.00	1.07	71.50	0.93	73.90	0.67	68.10
20000	—	—	—	—	—	—	1.22	68.90	1.12	70.50	0.98	73.00	0.71	67.10
21000	—	—	—	—	—	—	—	—	1.18	69.50	1.03	72.10	0.74	66.10
22000	—	—	—	—	—	—	—	—	1.23	68.50	1.08	71.30	0.77	65.10
23000	—	—	—	—	—	—	—	—	—	—	1.13	70.40	0.80	64.20
24000	—	—	—	—	—	—	—	—	—	—	1.18	69.50	0.84	63.20
25000	—	—	—	—	—	—	—	—	—	—	1.23	68.70	0.87	62.20
26000	—	—	—	—	—	—	—	—	—	—	—	—	0.90	61.20
27000	—	—	—	—	—	—	—	—	—	—	—	—	0.93	60.30
28000	—	—	—	—	—	—	—	—	—	—	—	—	0.97	59.30
29000	—	—	—	—	—	—	—	—	—	—	—	—	1.00	58.30



# Pressure Curves

## (60 Hz) Air-Cooled Condensers

Figure 57. Operating pressure curve (all comp. and cond. fans per ckt. on)—90 tons std. capacity

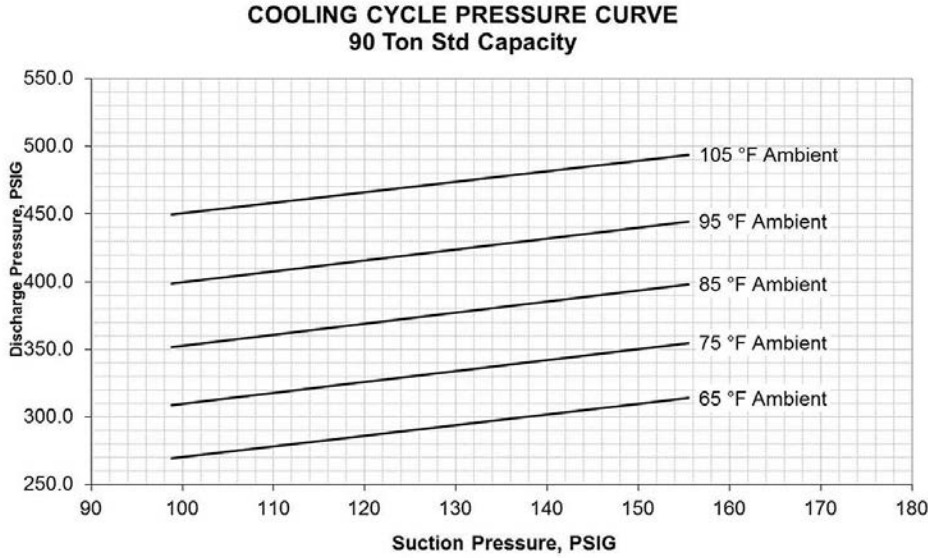
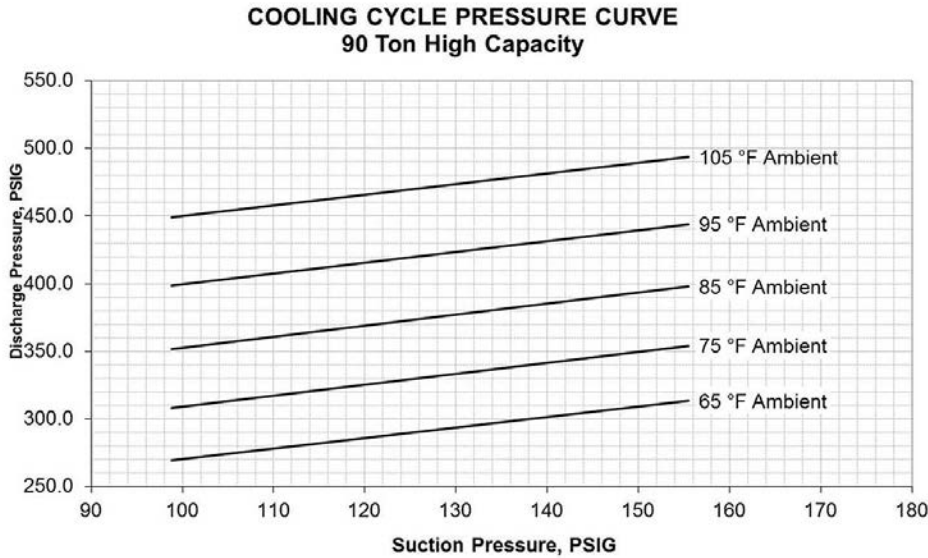
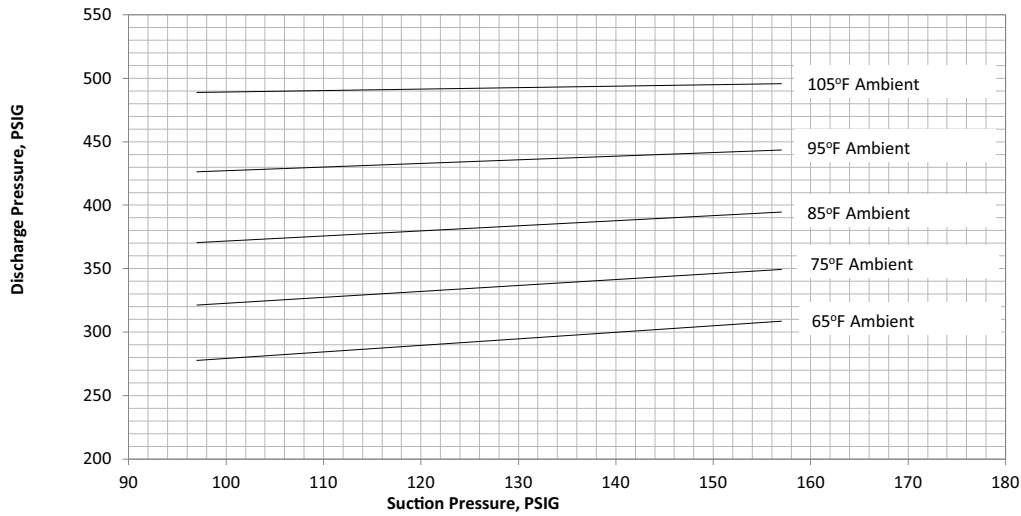


Figure 58. Operating pressure curve (all comp. and cond. fans per ckt. on)—90 tons high capacity

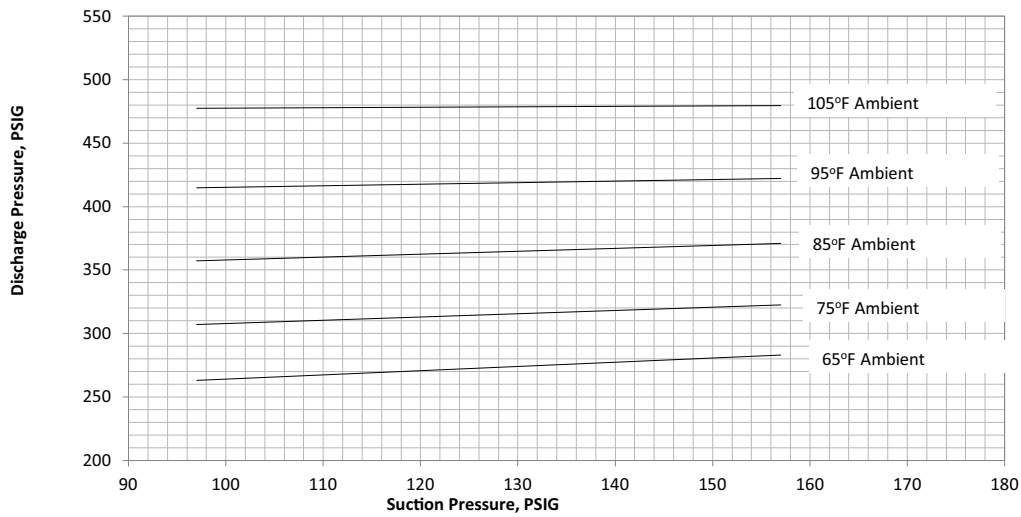


**Figure 59. 90 ton eFlex variable speed—circuit 1 and circuit 2 operating pressure curve (compressor at 100% and all condenser fans ON) (standard capacity)**

**90 Ton eFlex Circuit 1, 60Hz, Std Capacity**



**90 Ton eFlex Circuit 2, 60Hz, Std Capacity**

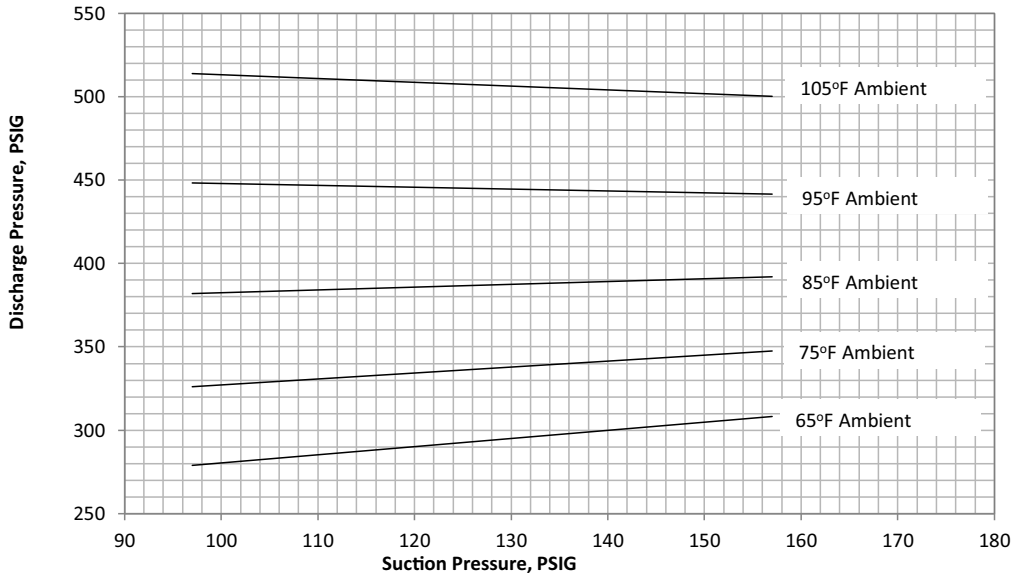




## Unit Startup

Figure 60. 90 ton eFlex variable speed—circuit 1 and circuit 2 operating pressure curve (compressor at 100% and all condenser fans ON) (high capacity)

### 90 Ton eFlex Circuit 1, 60Hz High Capacity



### 90 Ton eFlex Circuit 2, 60Hz High Capacity

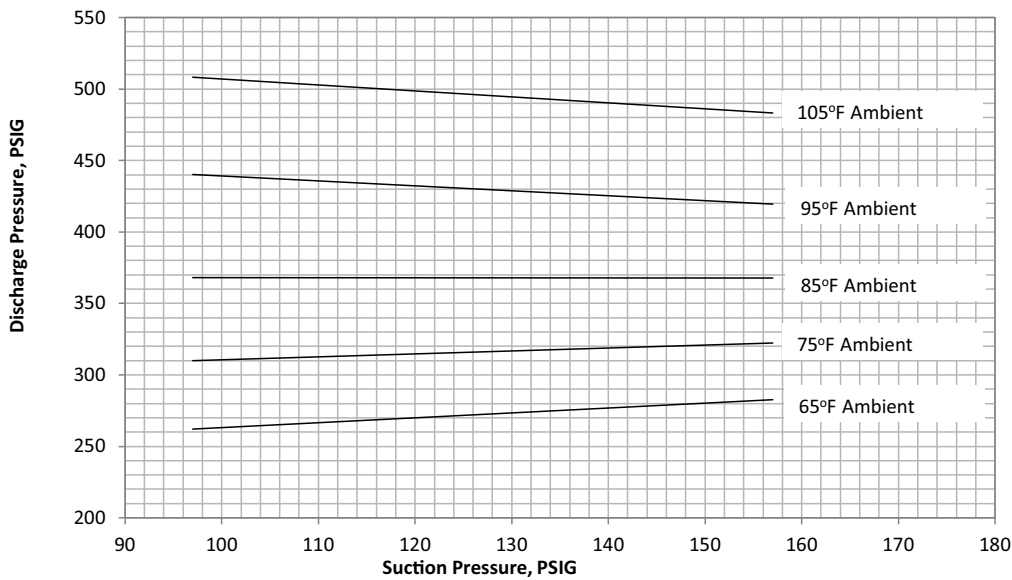




Figure 61. Operating pressure curve (all comp. and cond. fans per ckt. on)—105 tons std. capacity

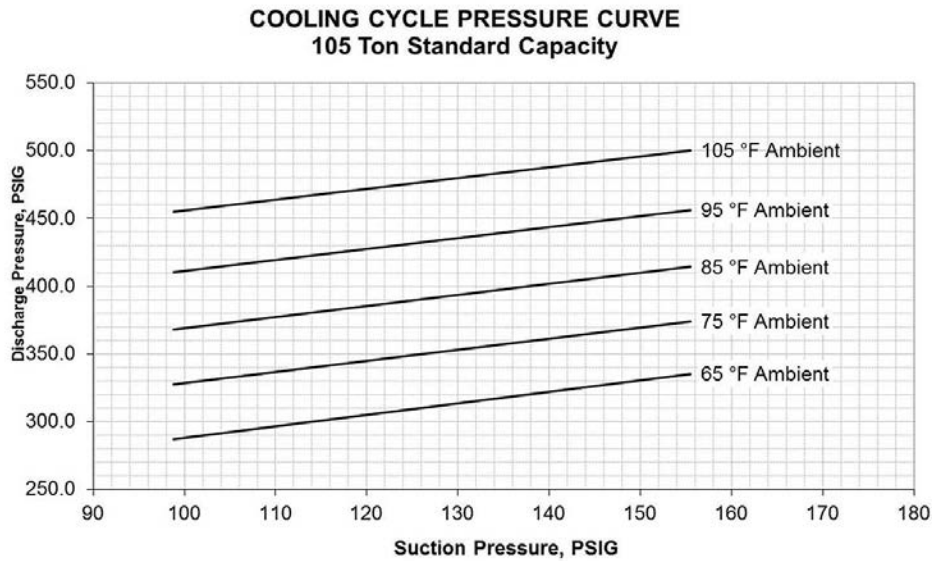
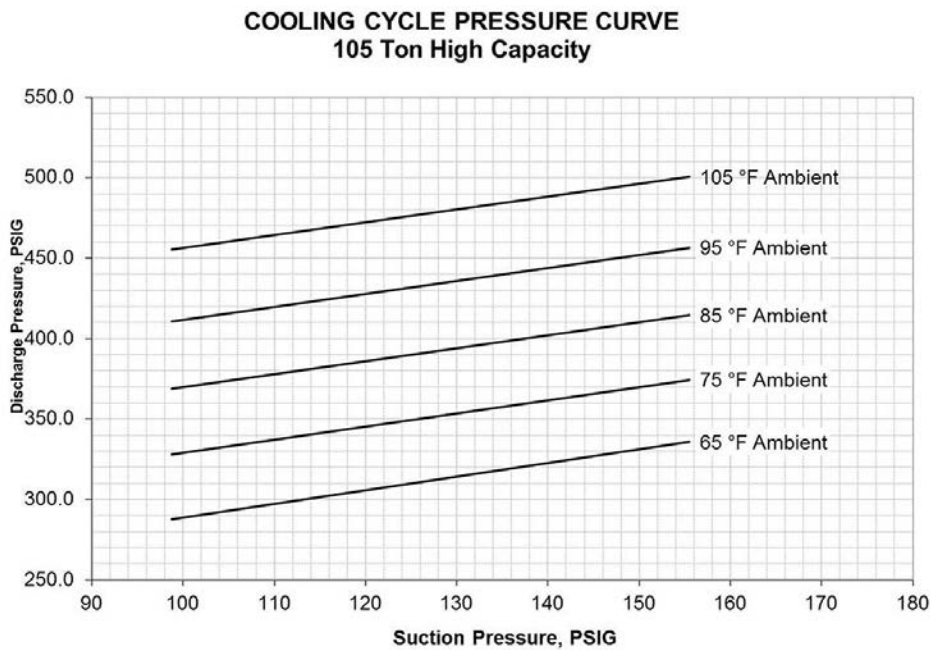


Figure 62. Operating pressure curve (all comp. and cond. fans per ckt. on)—105 tons high capacity

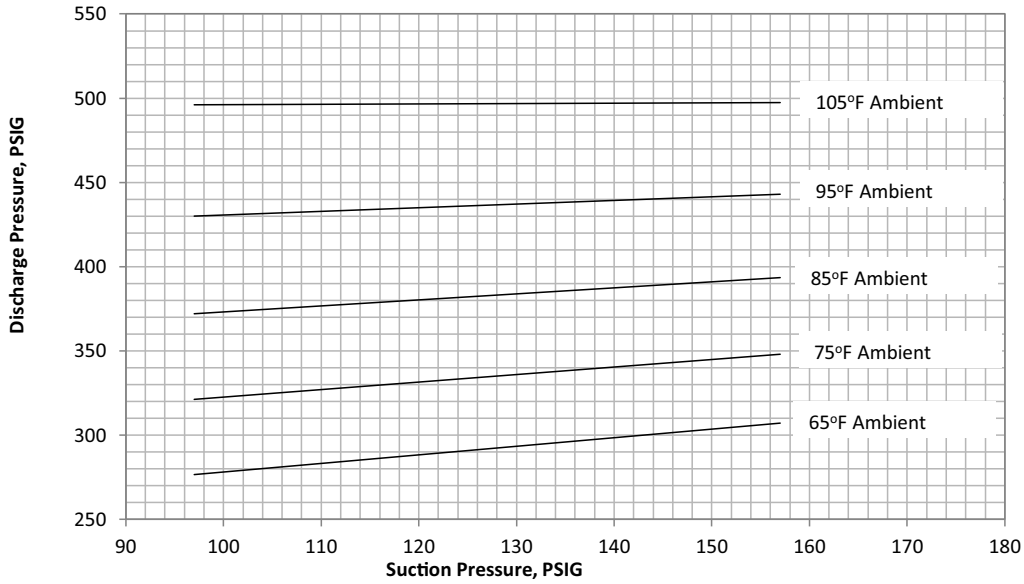




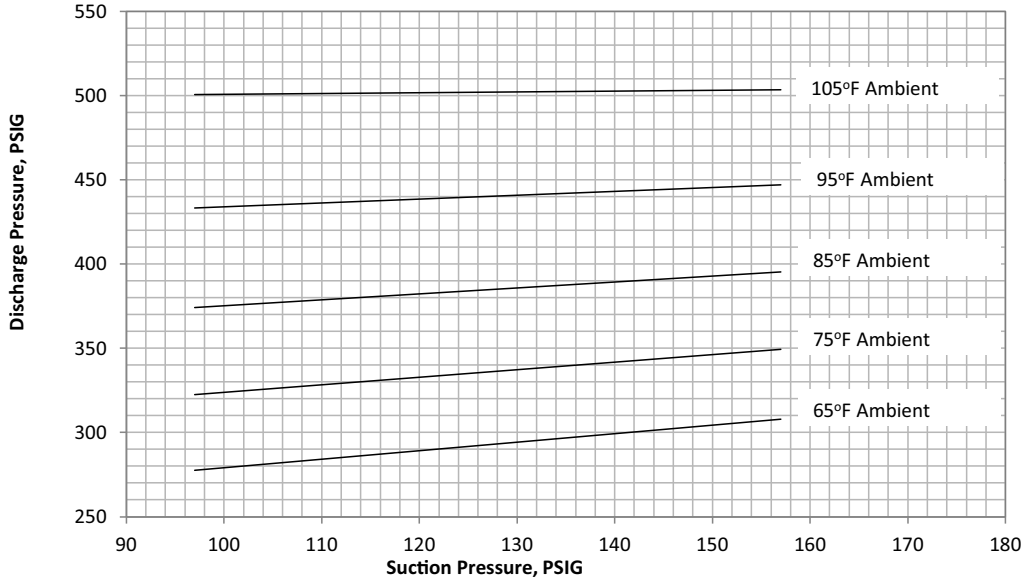
## Unit Startup

Figure 63. 105 ton eFlex variable speed—circuit 1 and circuit 2 operating pressure curve (compressor at 100% and all condenser fans ON) (standard capacity)

### 105 Ton eFlex Circuit 1, 60Hz, Std Capacity

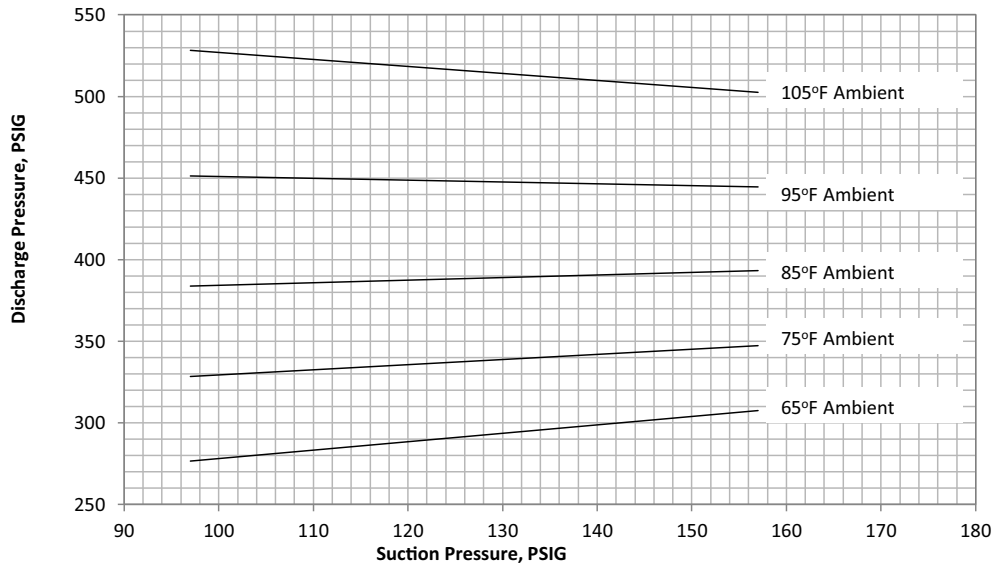


### 105 Ton eFlex Circuit 2, 60Hz, Std Capacity

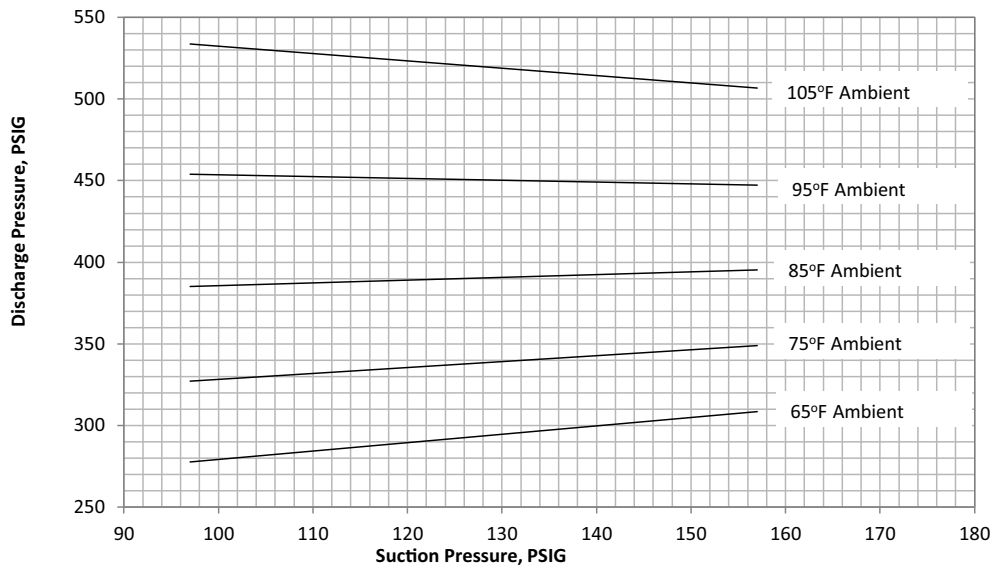


**Figure 64. 105 ton eFlex variable speed—circuit 1 and circuit 2 operating pressure curve (compressor at 100% and all condenser fans ON) (high capacity)**

**105 Ton eFlex Circuit 1, 60Hz High Capacity**



**105 Ton eFlex Circuit 2, 60Hz High Capacity**





## Unit Startup

Figure 65. Operating pressure curve (all comp. and cond. fans per ckt. on)—120 tons std. capacity

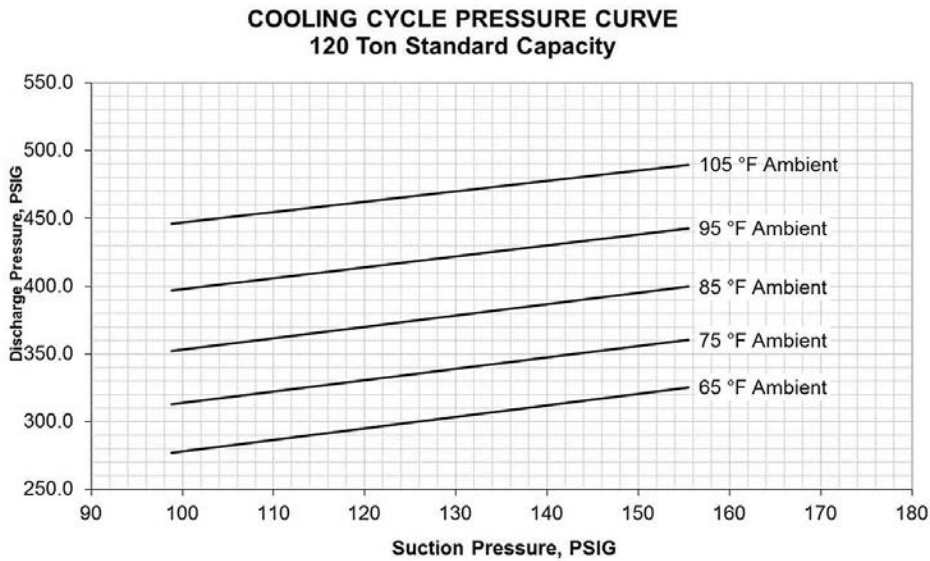
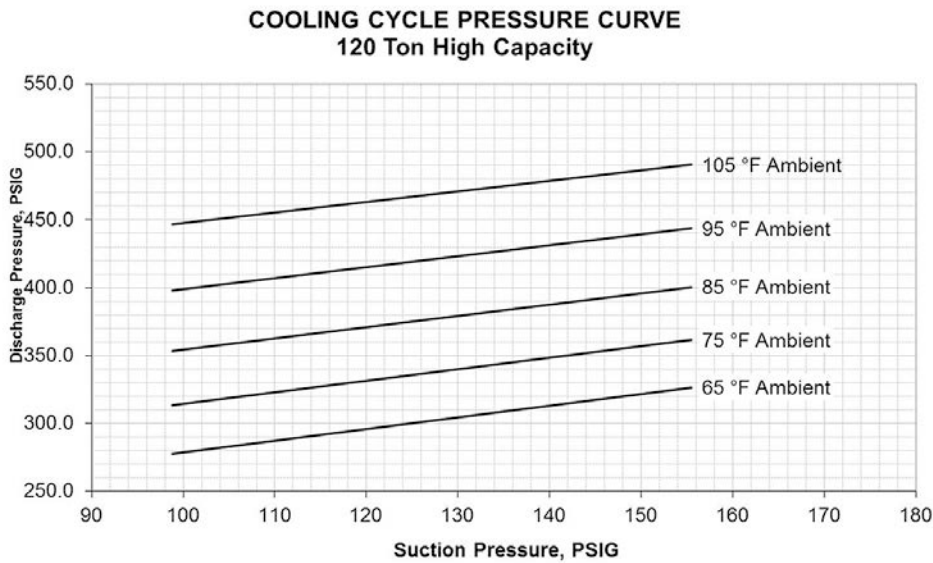
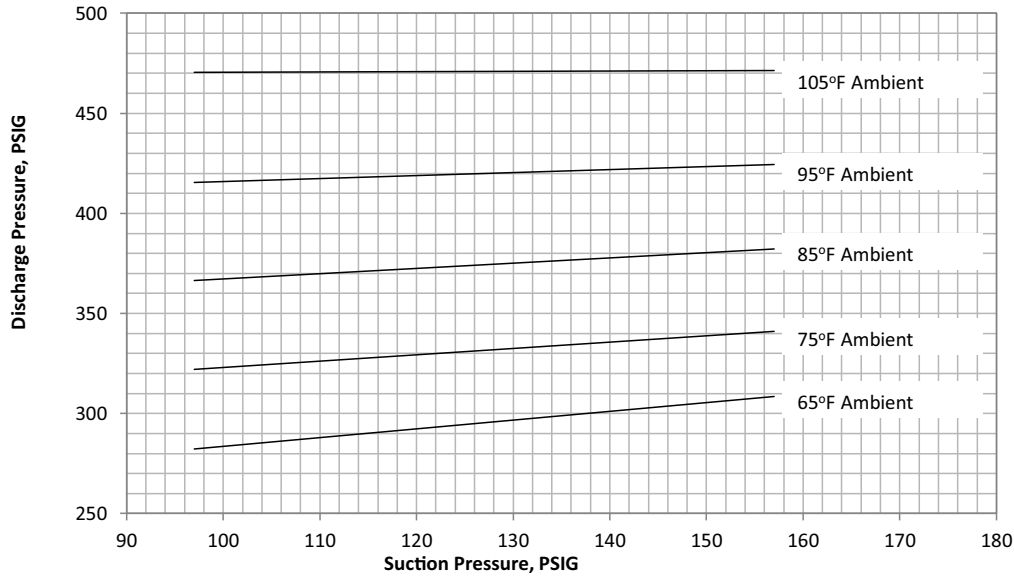


Figure 66. Operating pressure curve (all comp. and cond. fans per ckt. on)—120 tons high capacity

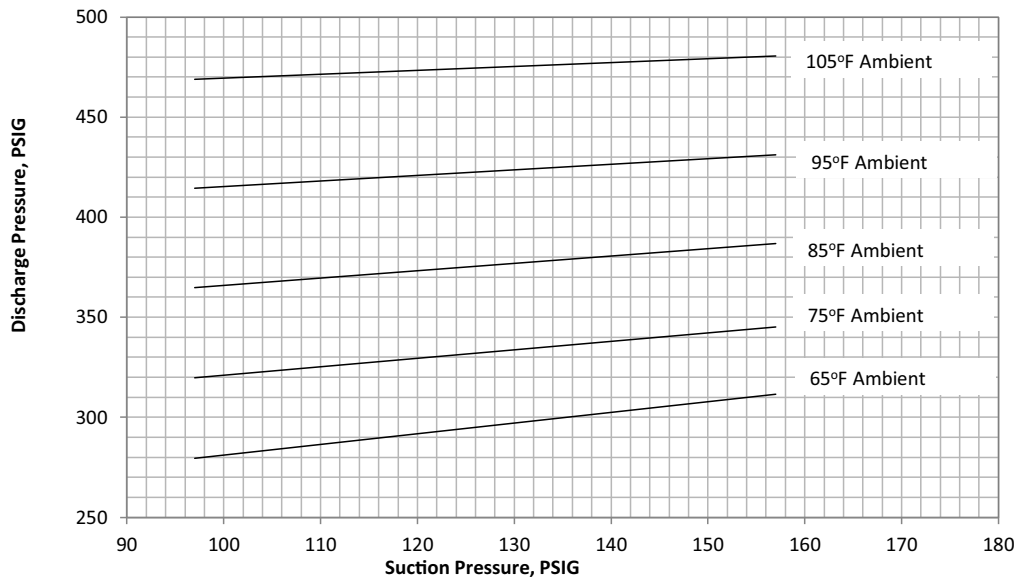


**Figure 67. 120 ton eFlex variable speed—circuit 1 and circuit 2 operating pressure curve (compressor at 100% and all condenser fans ON) (standard capacity)**

**120 Ton eFlex Circuit 1, 60Hz, Std Capacity**



**120 Ton eFlex Circuit 2, 60Hz, Std Capacity**

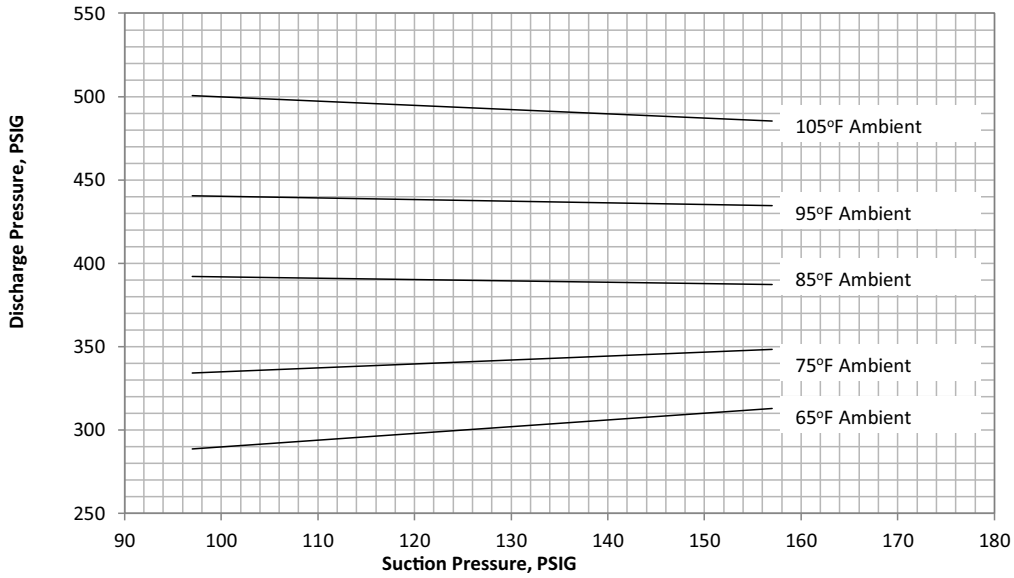




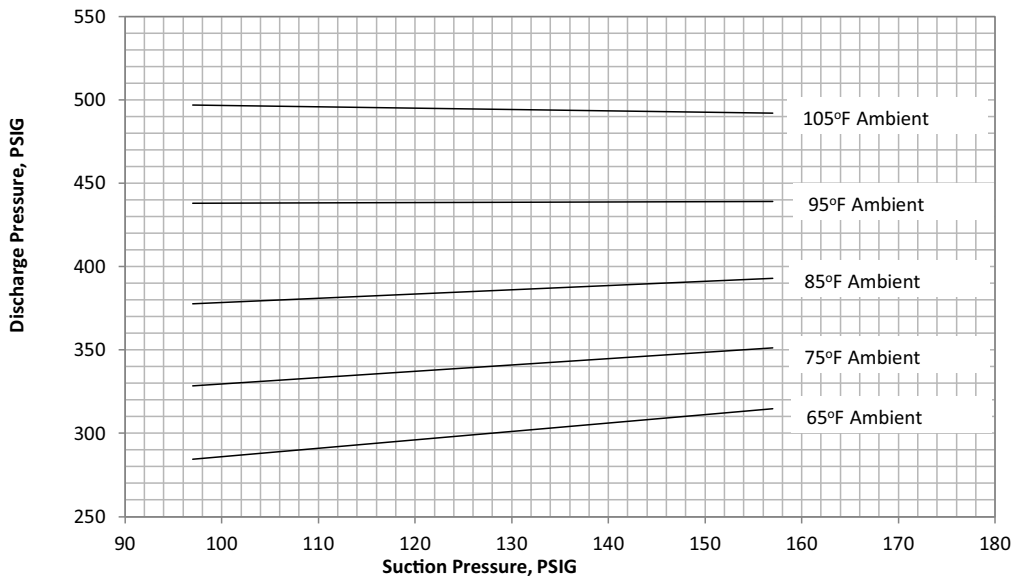
## Unit Startup

Figure 68. 120 ton eFlex variable speed—circuit 1 and circuit 2 operating pressure curve (compressor at 100% and all condenser fans ON) (high capacity)

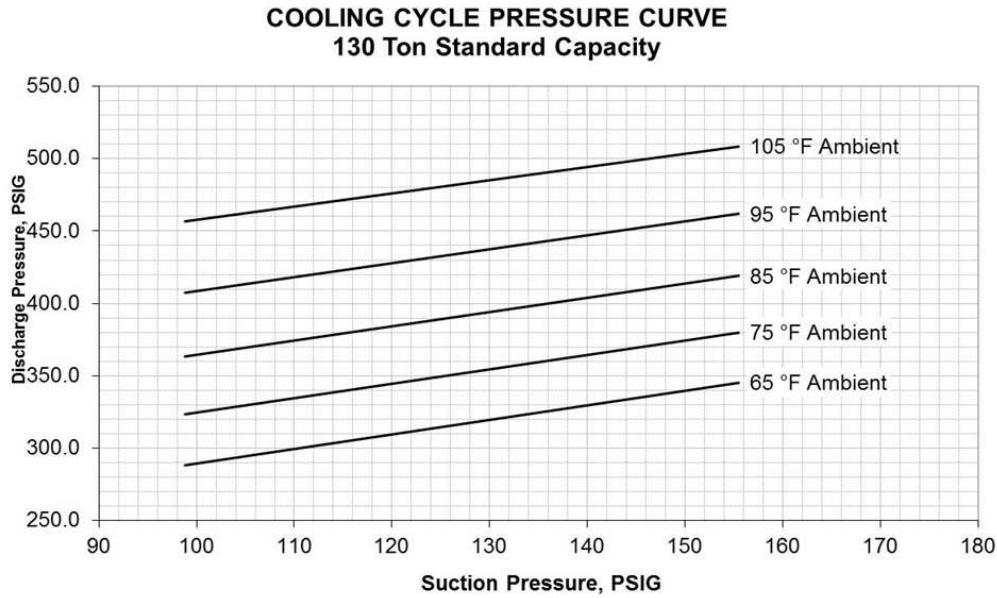
### 120 Ton eFlex Circuit 1, 60Hz High Capacity



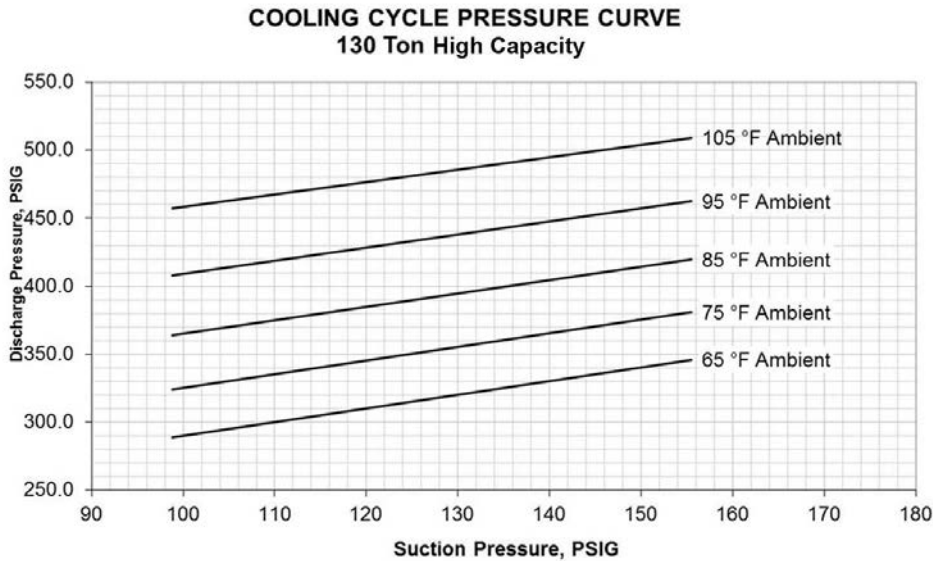
### 120 Ton eFlex Circuit 2, 60Hz High Capacity



**Figure 69. Operating Pressure Curve (All Comp. and Cond. Fans per ckt. on)—130 Tons Std. Capacity**



**Figure 70. Operating Pressure Curve (All Comp. and Cond. Fans per ckt. on)—130 Tons High Capacity**

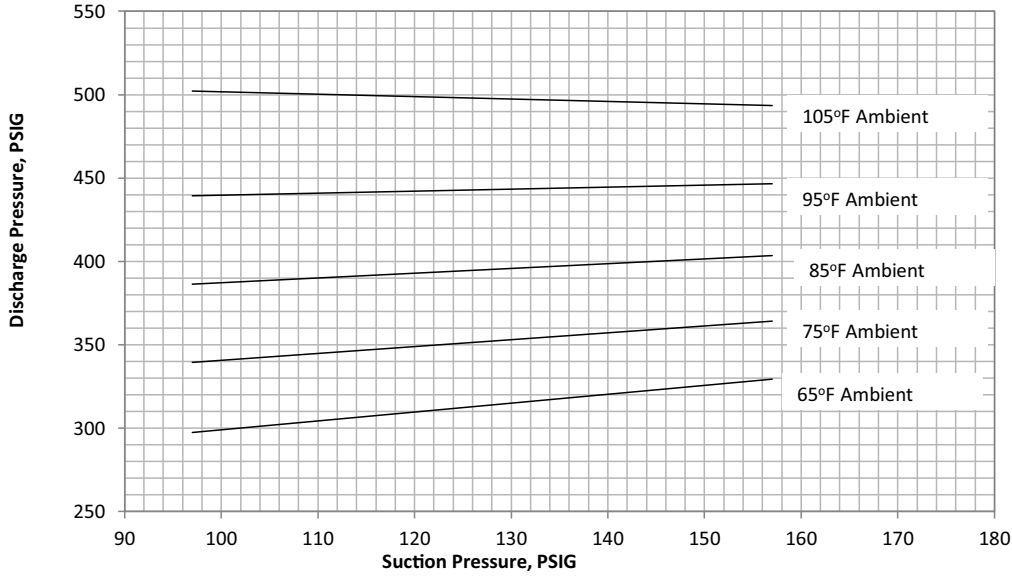




## Unit Startup

Figure 71. 130 ton eFlex variable speed—circuit 1 and circuit 2 operating pressure curve (compressor at 100% and all condenser fans ON) (standard capacity)

### 130 Ton eFlex Circuit 1, 60Hz, Std Capacity



### 130 Ton eFlex Circuit 2, 60Hz, Std Capacity

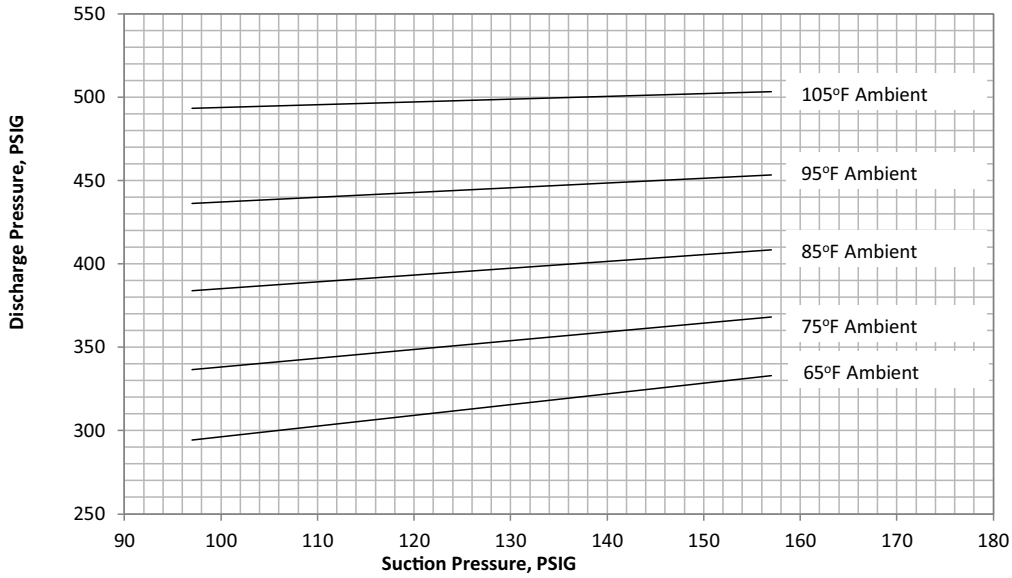
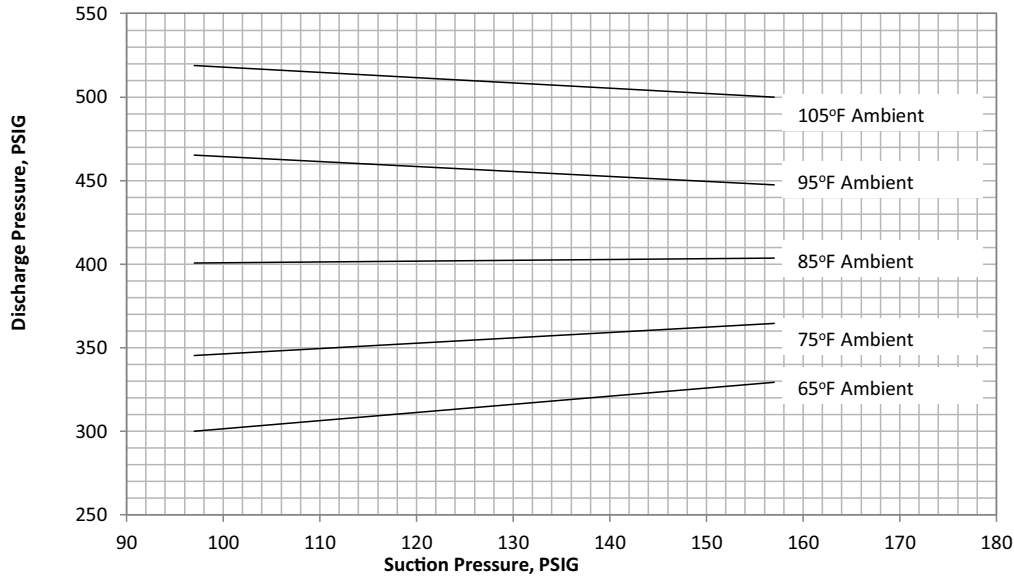


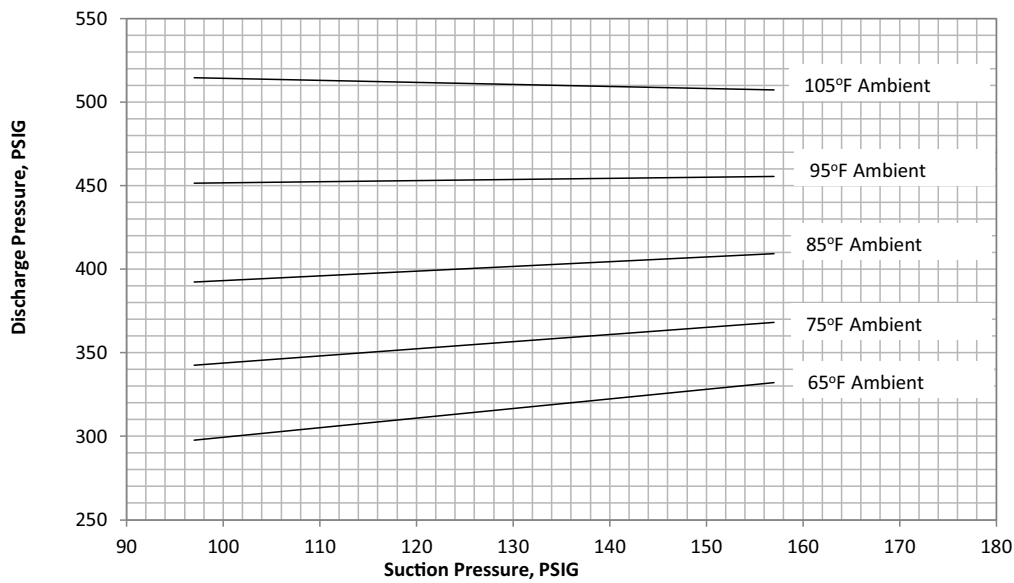


Figure 72. 130 ton eFlex variable speed—circuit 1 and circuit 2 operating pressure curve (compressor at 100% and all condenser fans ON) (high capacity)

### 130 Ton eFlex Circuit 1, 60Hz High Capacity



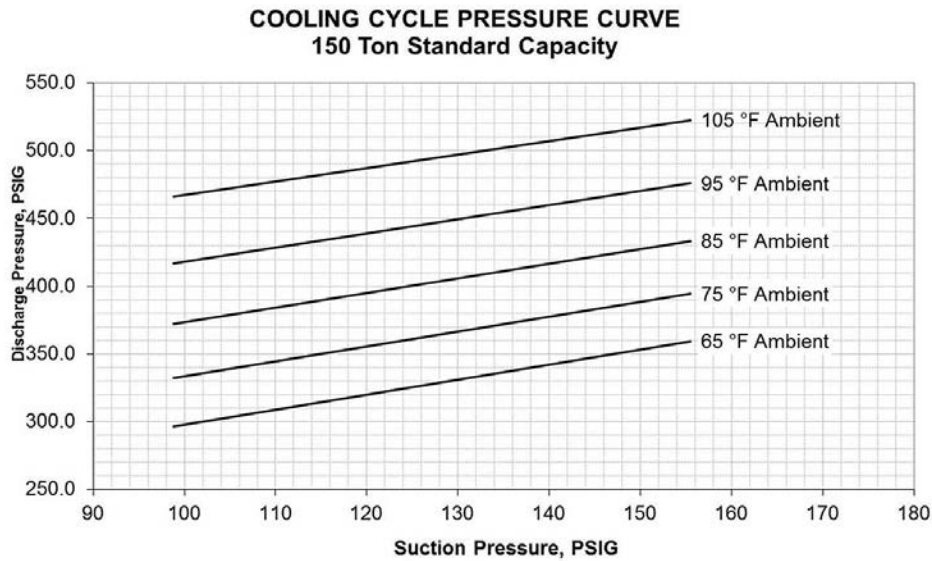
### 130 Ton eFlex Circuit 2, 60Hz High Capacity





## Unit Startup

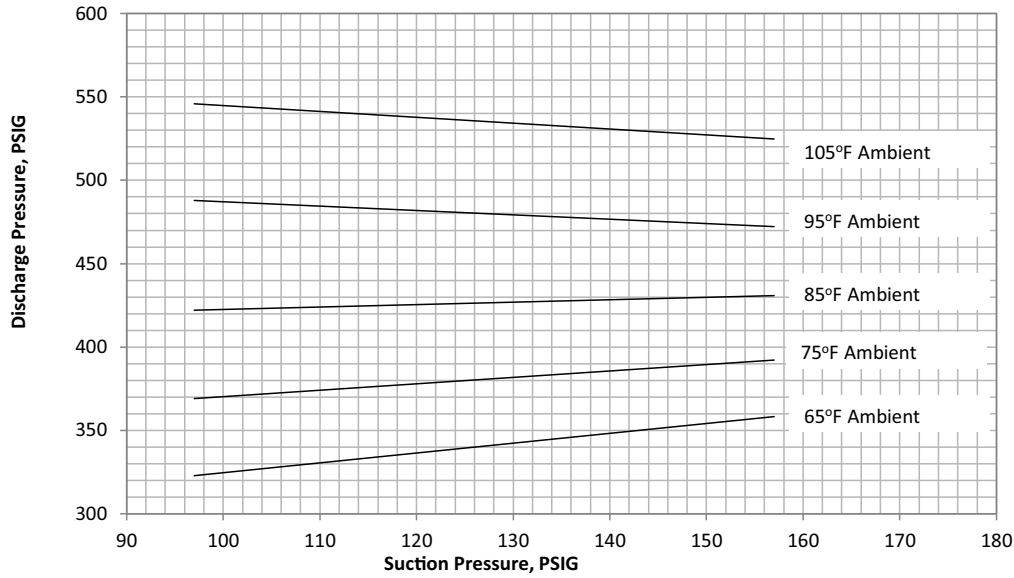
Figure 73. Operating pressure curve (all comp. and cond. fans per ckt. on)—150 ton std. capacity



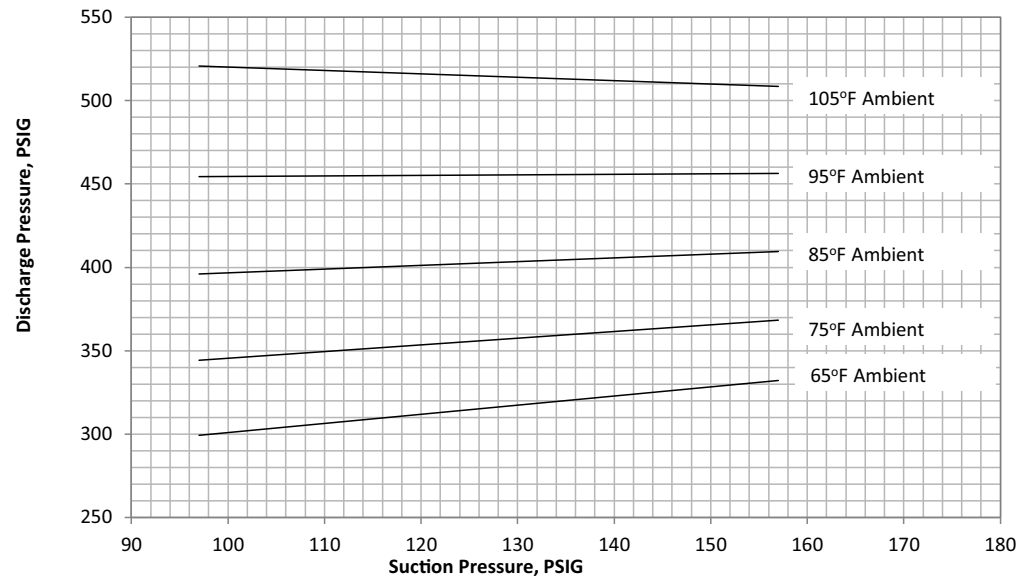
**Note:** Due to the variable speed fans on Evaporative Condenser units, typical operating pressure curves are not relevant. If operating pressures at certain conditions are needed, contact a local Trane sales representative.

**Figure 74. 150 ton eFlex variable speed—circuit 1 and circuit 2 operating pressure curve (compressor at 100% and all condenser fans ON) (standard capacity)**

**150 Ton eFlex Circuit 1, 60Hz**



**150 Ton eFlex Circuit 2, 60Hz**





## Unit Startup

### (50 Hz) Air-Cooled Condensers

Figure 75. Operating pressure curve (all comp. and cond. fans per ckt. on)—90 tons standard capacity

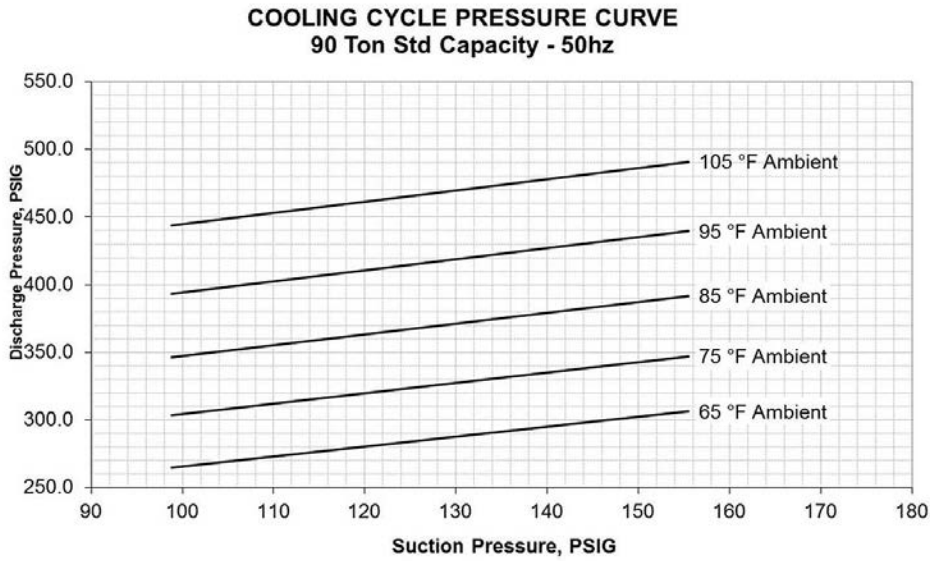
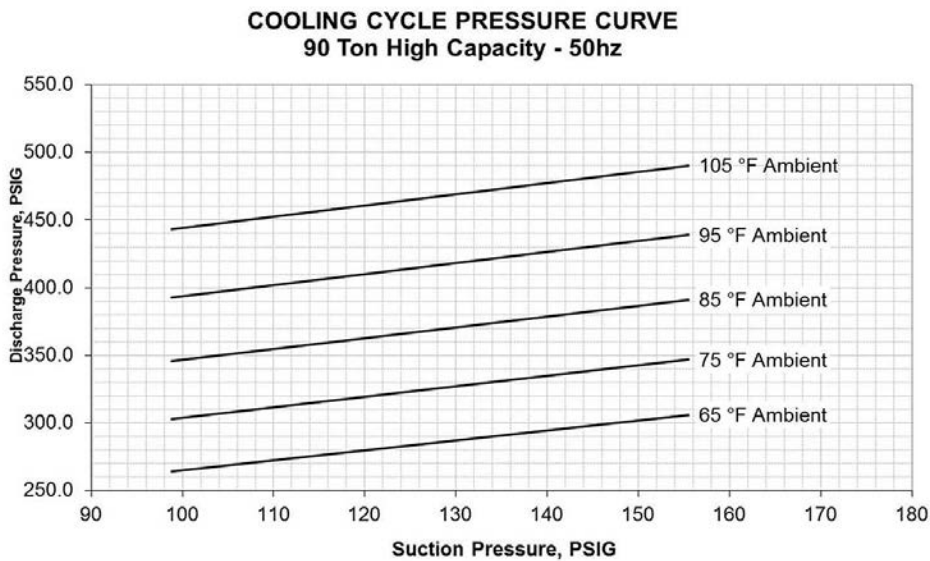
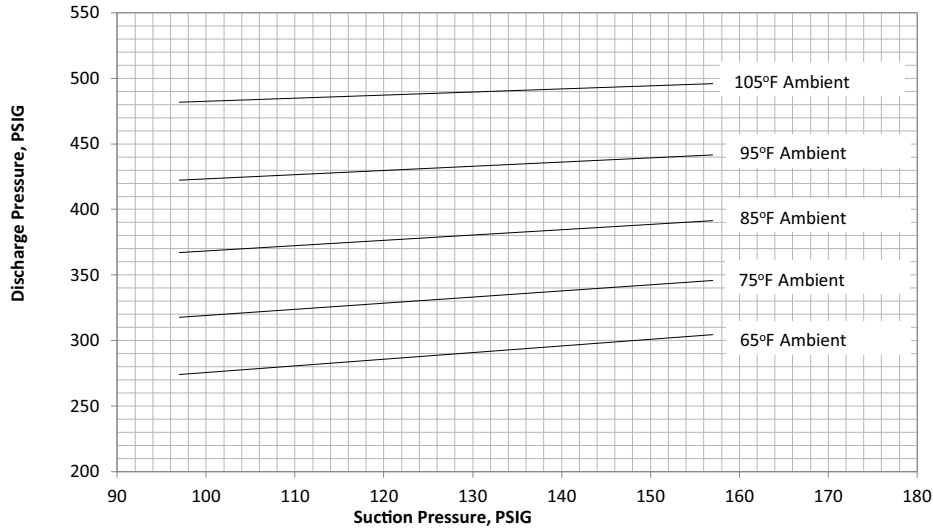


Figure 76. Operating pressure curve (all comp. and cond. fans per ckt. on)—90 tons high capacity

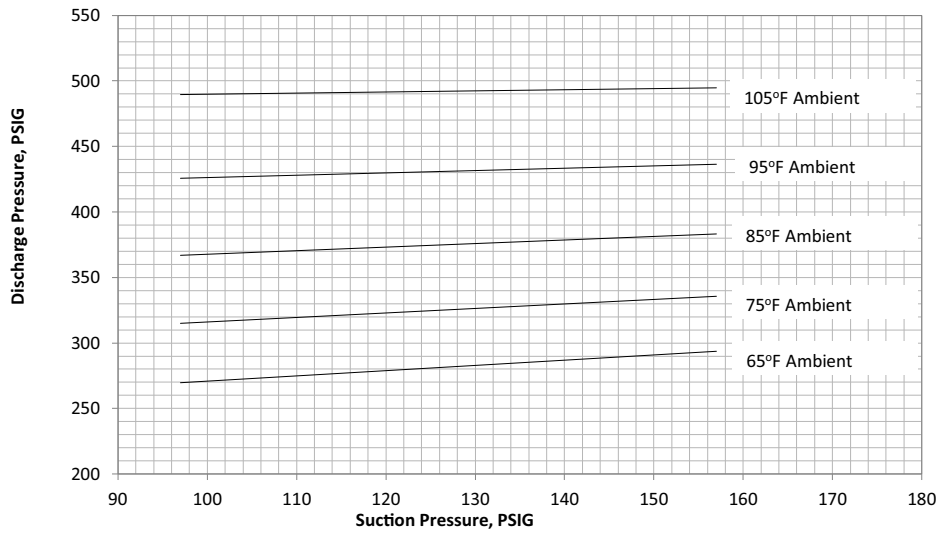


**Figure 77. 90 ton eFlex variable speed—circuit 1 and circuit 2 operating pressure curve (compressor at 100% and all condenser fans ON) (standard capacity)**

**90 Ton eFlex Circuit 1, 50Hz**



**90 Ton eFlex Circuit 2, 50Hz**

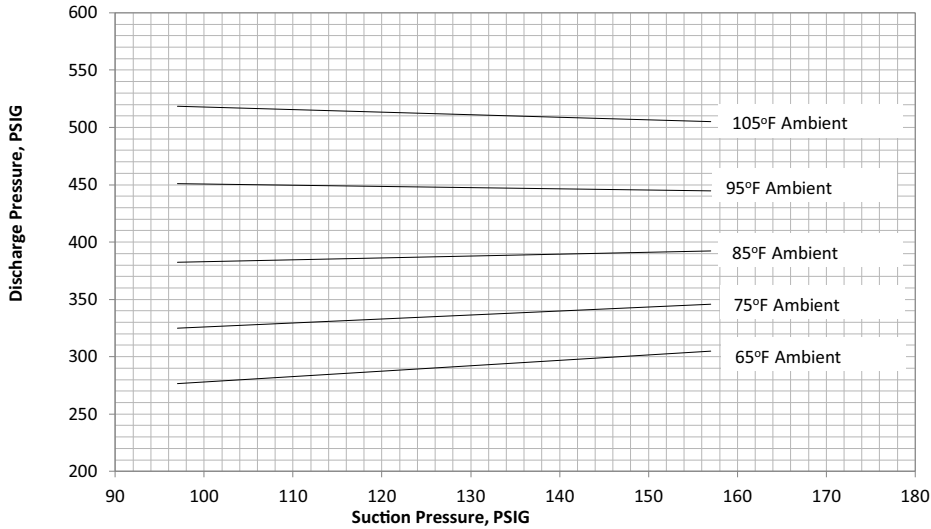




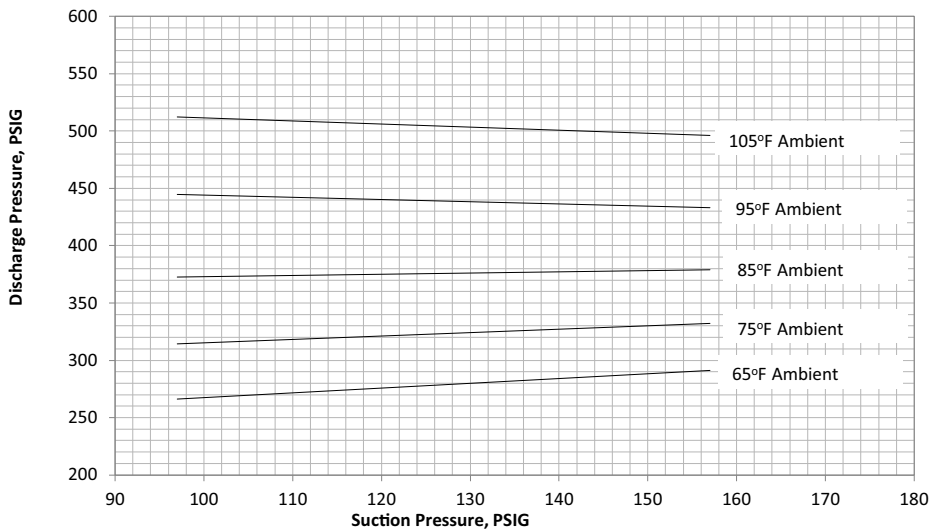
## Unit Startup

Figure 78. 90 ton eFlex variable speed—circuit 1 and circuit 2 operating pressure curve (compressor at 100% and all condenser fans ON) (high capacity)

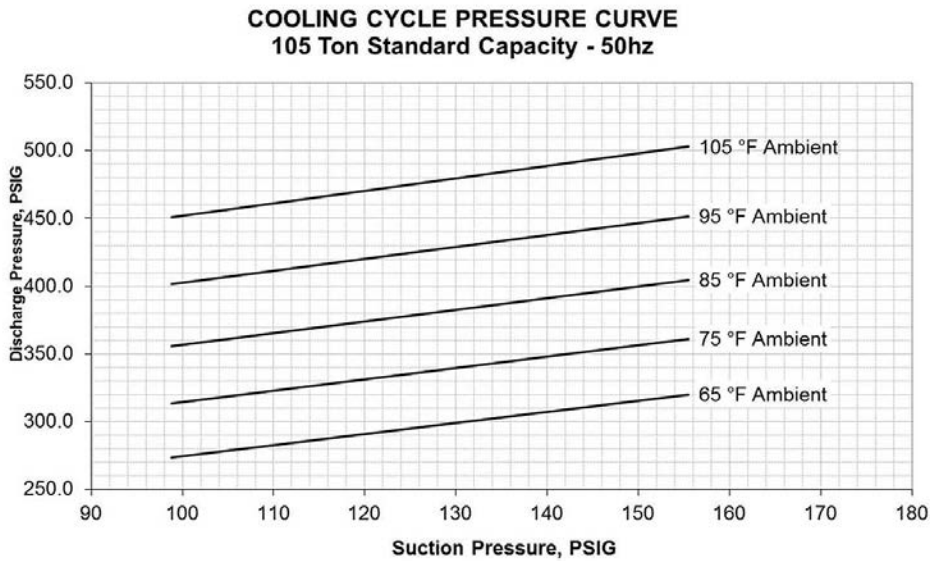
### 90 Ton eFlex Circuit 1, 50Hz High Capacity



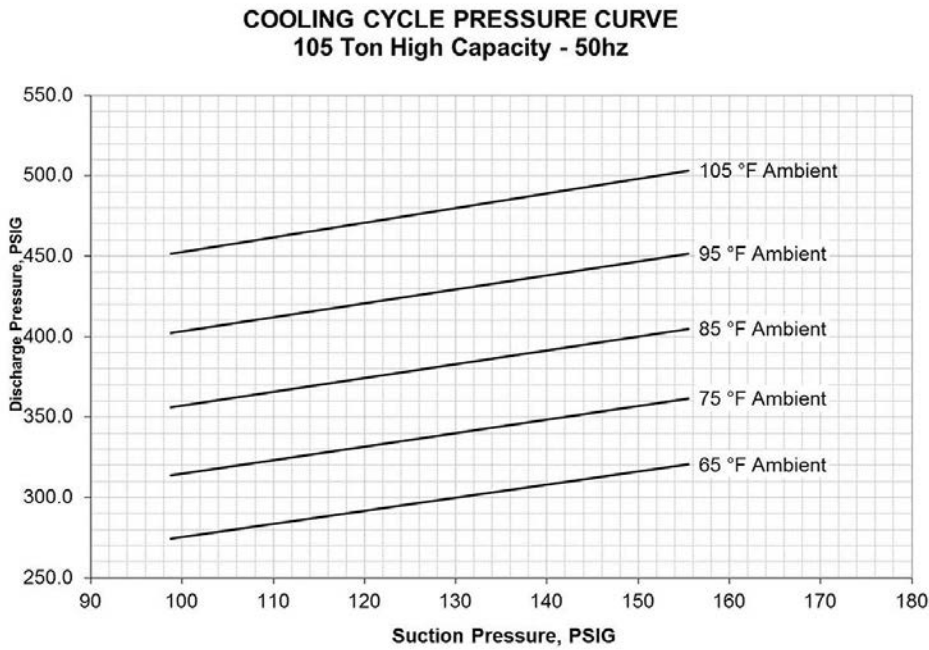
### 90 Ton eFlex Circuit 2, 50Hz High Capacity



**Figure 79. Operating pressure curve (all comp. and cond. fans per ckt. on)—105 tons standard capacity**



**Figure 80. Operating pressure curve (all comp. and cond. fans per ckt. on)—105 tons high capacity**

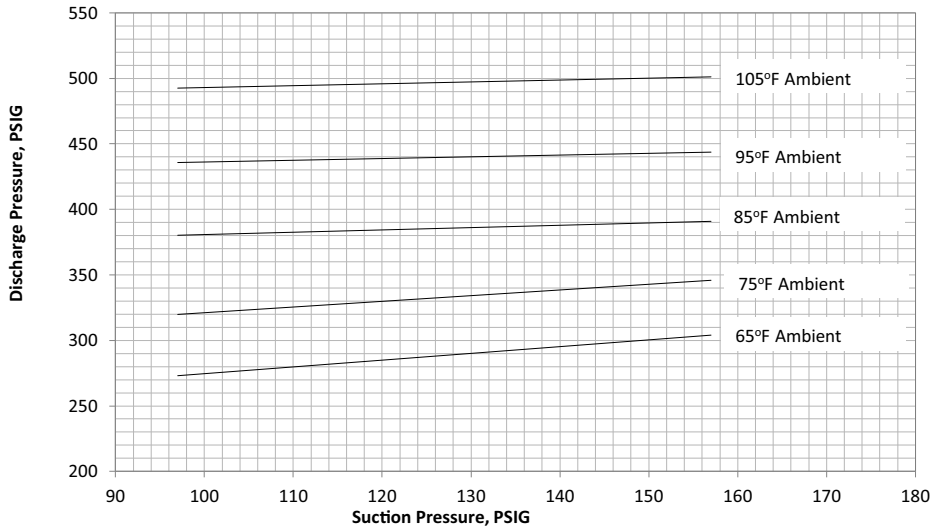




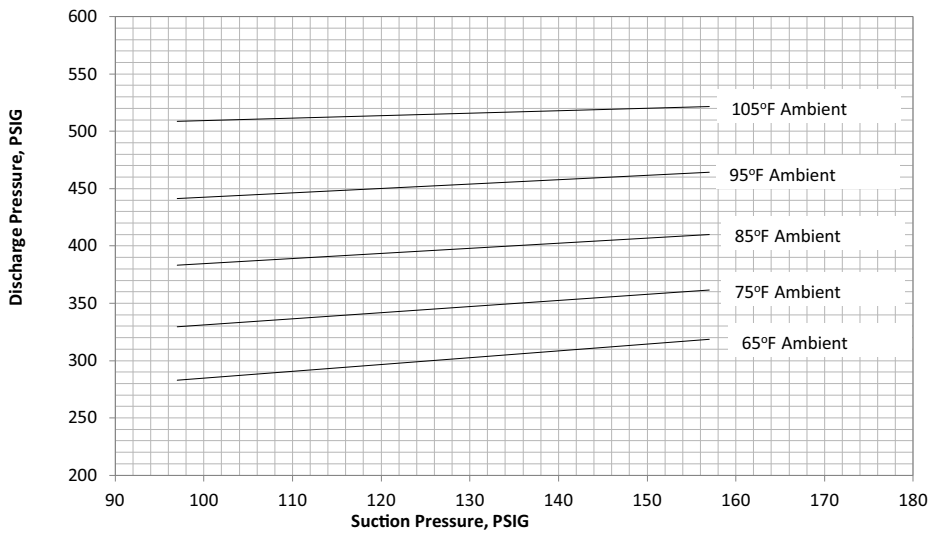
## Unit Startup

Figure 81. 105 ton eFlex variable speed—circuit 1 and circuit 2 operating pressure curve (compressor at 100% and all condenser fans ON) (standard capacity)

### 105 Ton eFlex Circuit 1, 50Hz



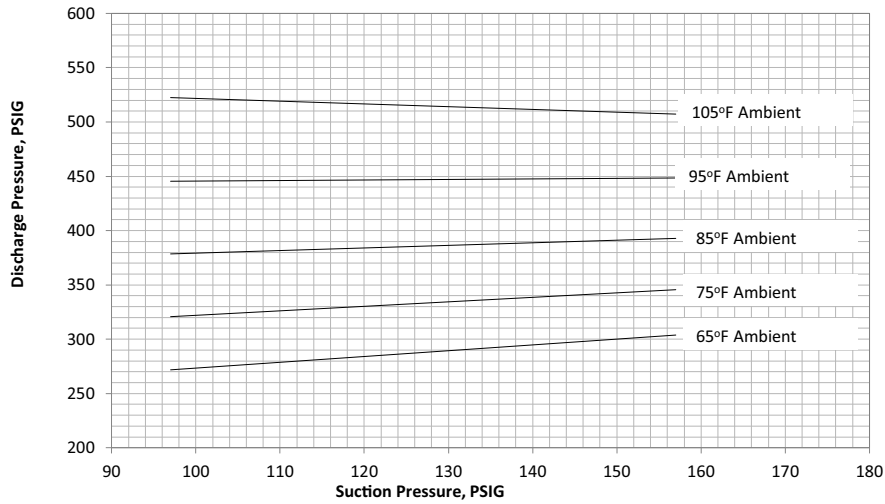
### 105 Ton eFlex Circuit 2, 50Hz



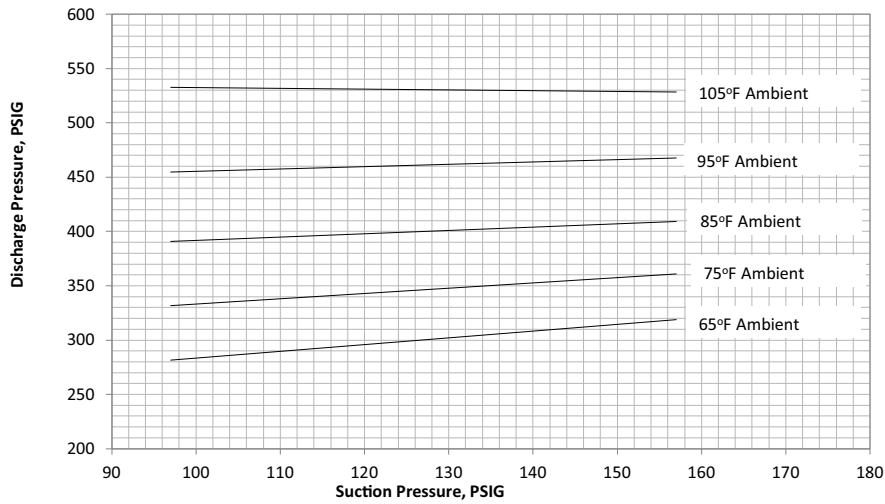


**Figure 82. 105 ton eFlex variable speed—circuit 1 and circuit 2 operating pressure curve (compressor at 100% and all condenser fans ON) (high capacity)**

**105 Ton eFlex Circuit 1, 50Hz High Capacity**



**105 Ton eFlex Circuit 2, 50Hz High Capacity**





## Unit Startup

Figure 83. Operating pressure curve (all comp. and cond. fans per ckt. on)—120 tons standard capacity

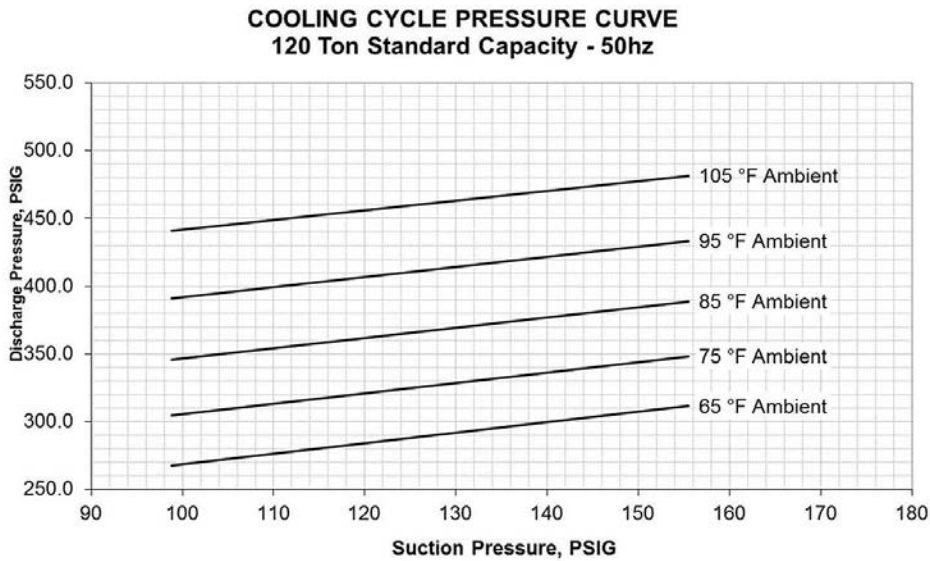
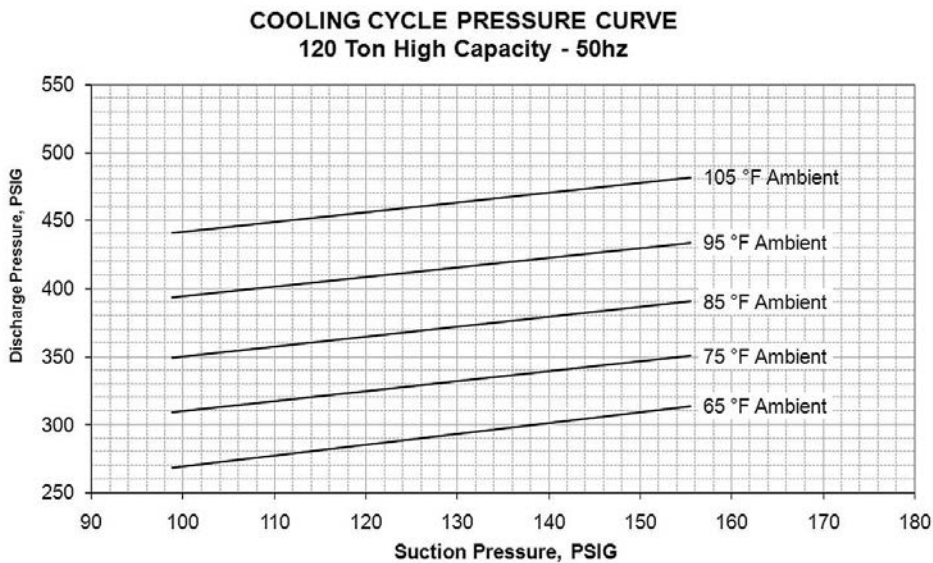
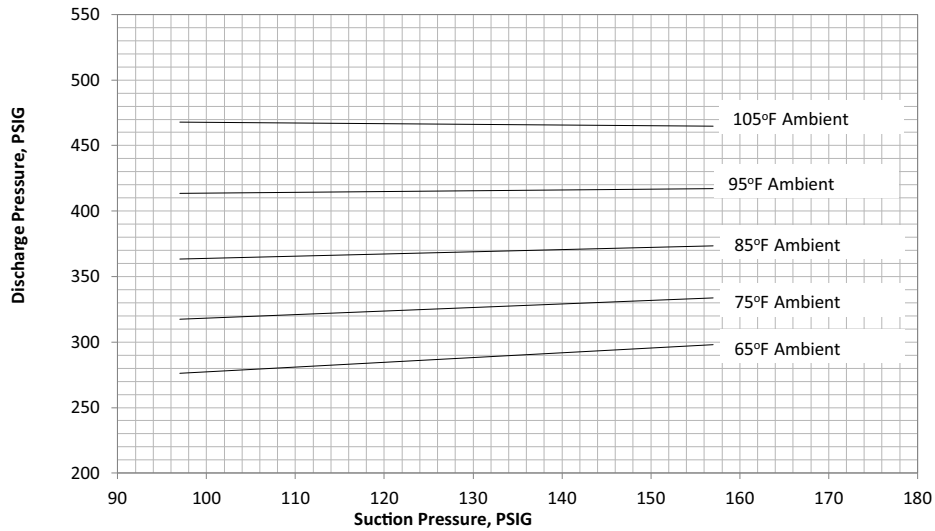


Figure 84. Operating pressure curve (all comp. and cond. fans per ckt. on)—120 tons high capacity

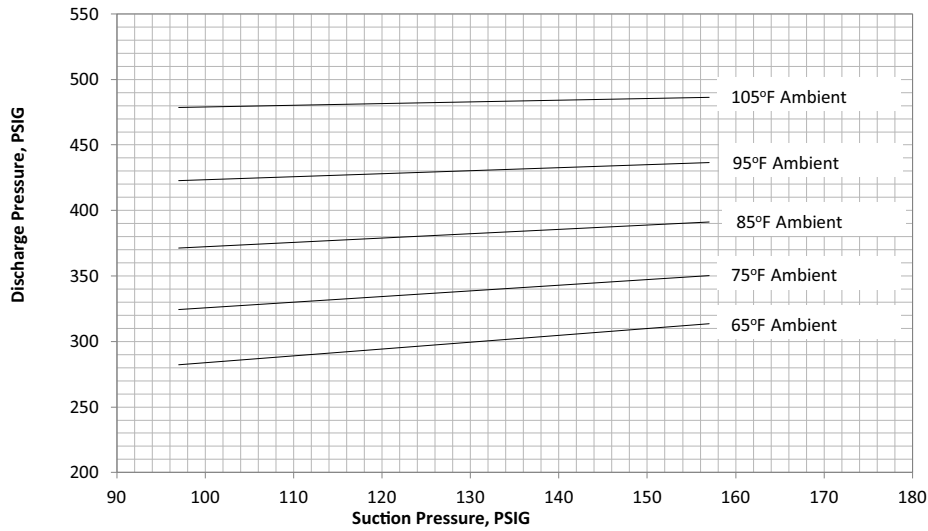


**Figure 85. 120 ton eFlex variable speed—circuit 1 and circuit 2 operating pressure curve (compressor at 100% and all condenser fans ON) (standard capacity)**

**120 Ton eFlex Circuit 1, 50Hz**



**120 Ton eFlex Circuit 1, 50Hz**

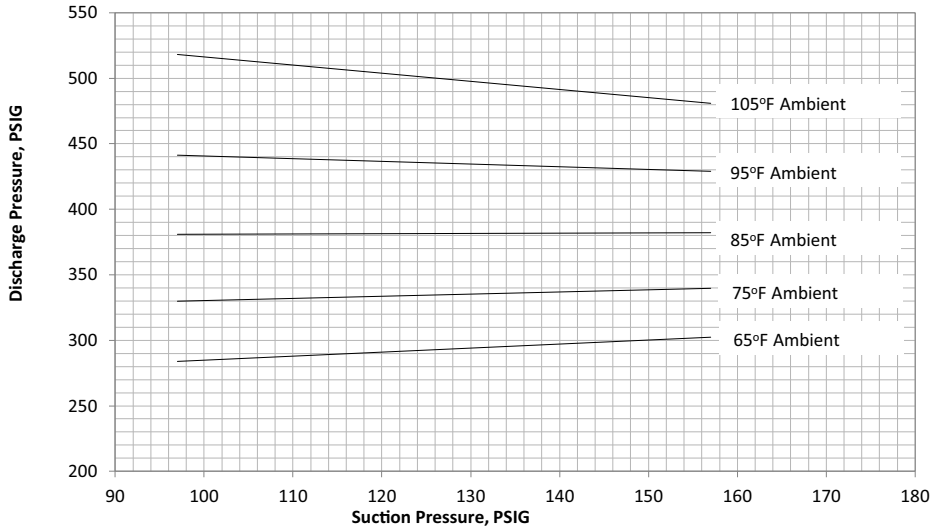




## Unit Startup

Figure 86. 120 ton eFlex variable speed—circuit 1 and circuit 2 operating pressure curve (compressor at 100% and all condenser fans ON) (high capacity)

### 120 Ton eFlex Circuit 1, 50Hz High Capacity



### 120 Ton eFlex Circuit 2, 50Hz High Capacity

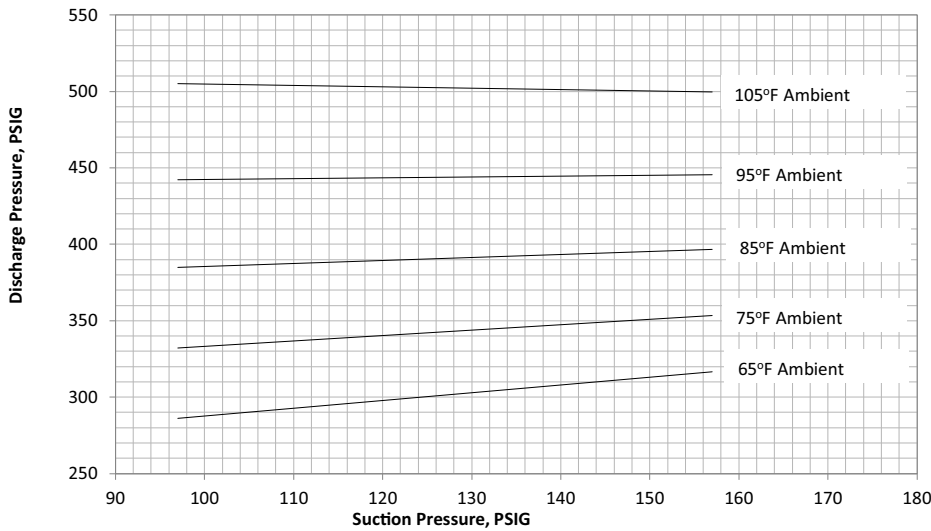


Figure 87. Operating pressure curve (all comp. and cond. fans per ckt. on)—130 tons standard capacity

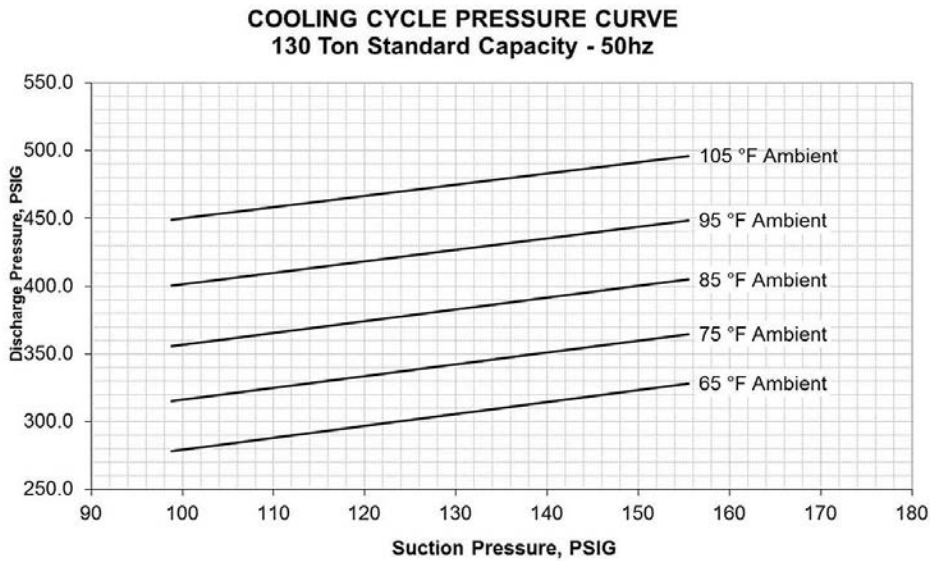
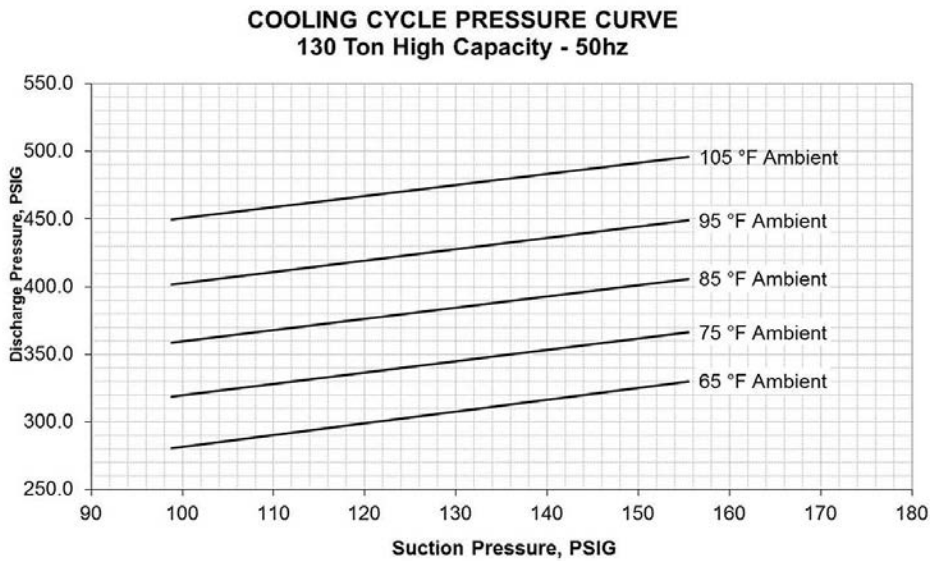


Figure 88. Operating pressure curve (all comp. and cond. fans per ckt. on)—130 tons high capacity

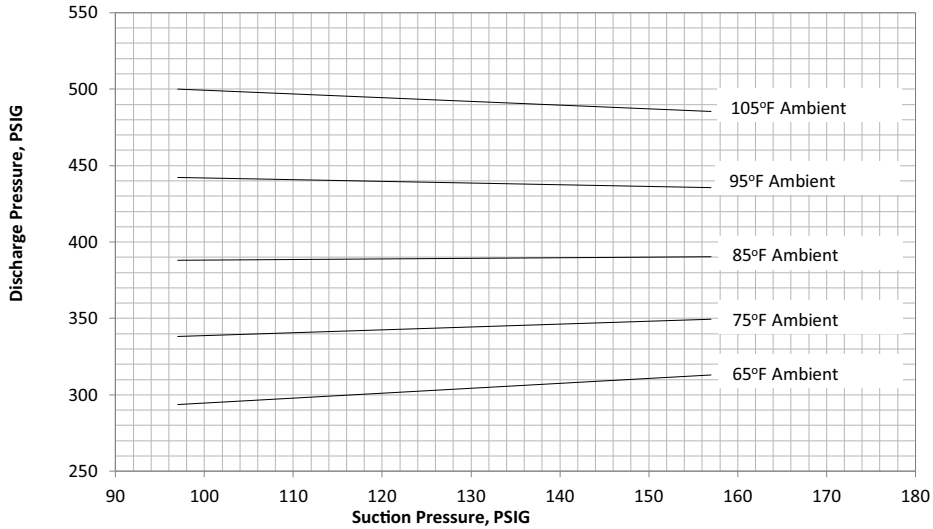




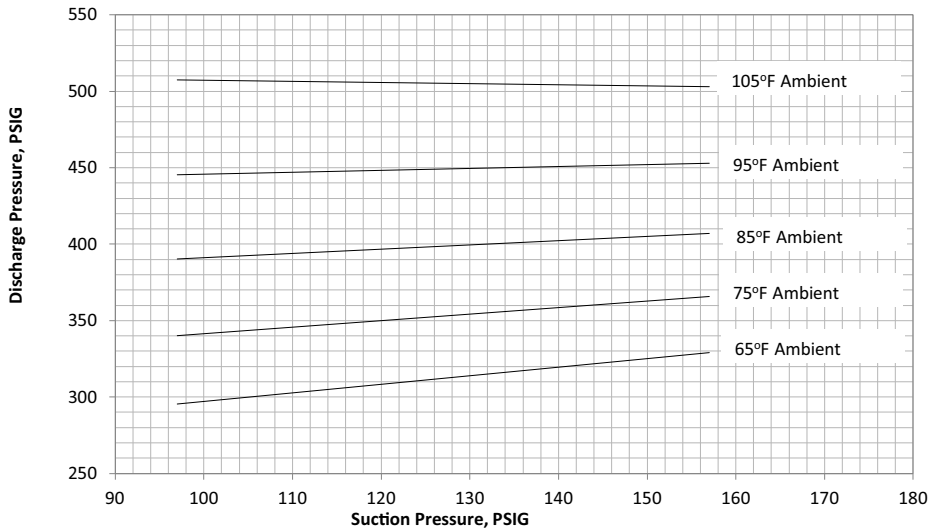
## Unit Startup

Figure 89. 130 ton eFlex variable speed—circuit 1 and circuit 2 operating pressure curve (compressor at 100% and all condenser fans ON) (standard capacity)

### 130 Ton eFlex Circuit 1, 50Hz

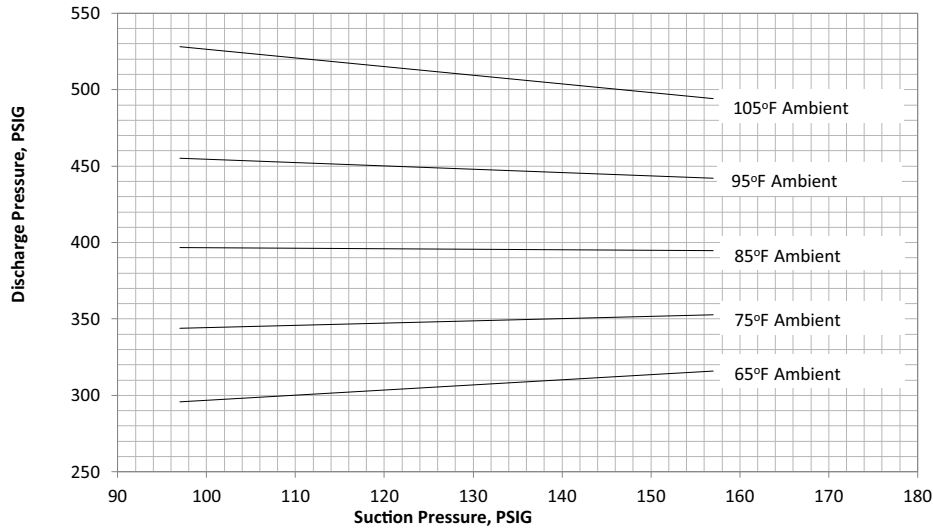


### 130 Ton eFlex Circuit 2, 50Hz

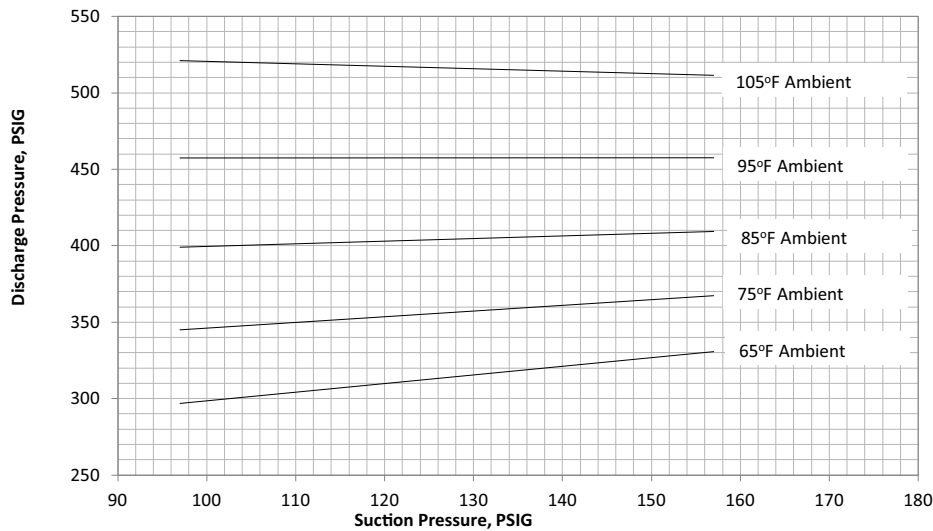


**Figure 90. 130 ton eFlex variable speed—circuit 1 and circuit 2 operating pressure curve (compressor at 100% and all condenser fans ON) (high capacity)**

**130 Ton eFlex Circuit 1, 50Hz High Capacity**



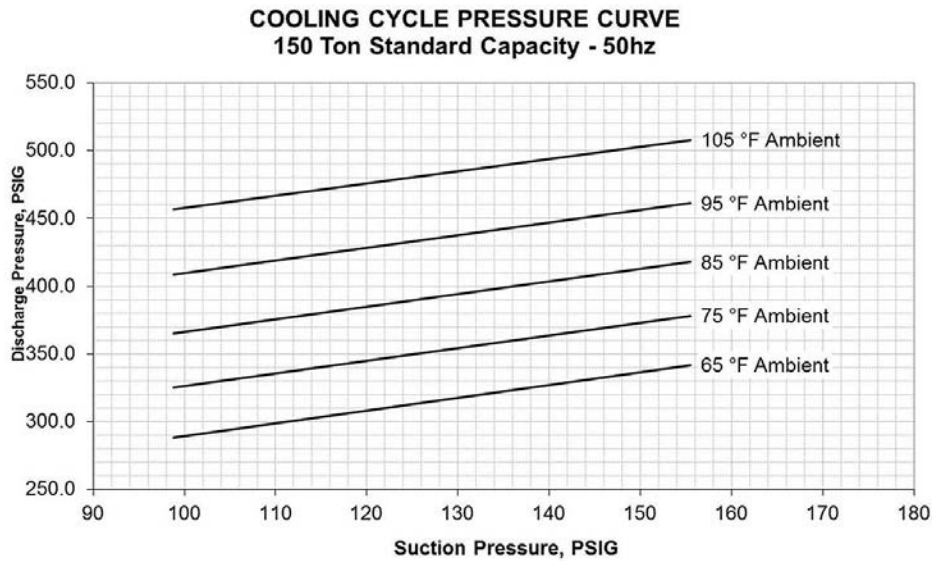
**130 Ton eFlex Circuit 2, 50Hz High Capacity**





## Unit Startup

Figure 91. Operating pressure curve (all comp. and cond. fans per ckt. on)—150 tons standard capacity

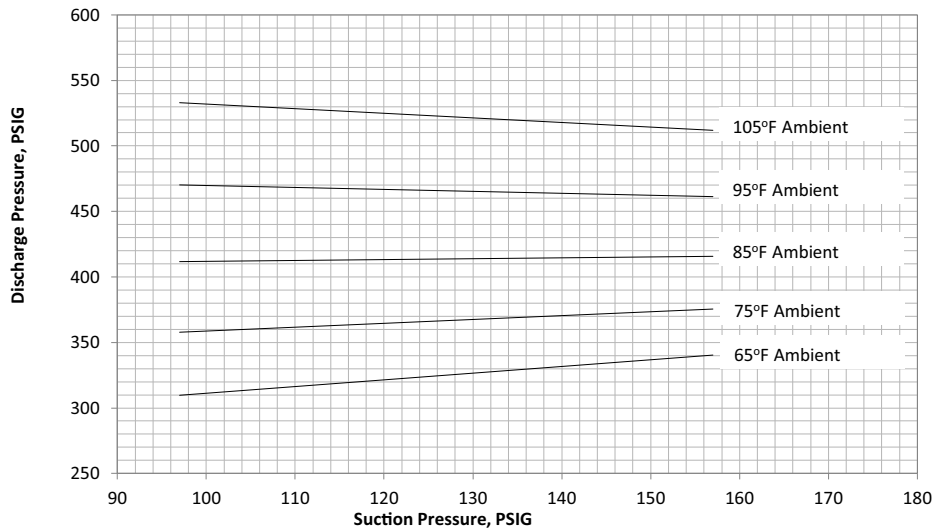


**Note:** Due to the variable speed fans on evaporative condenser units, typical operating pressure curves are not relevant. If operating pressures at certain conditions are needed, contact a local Trane sales representative.

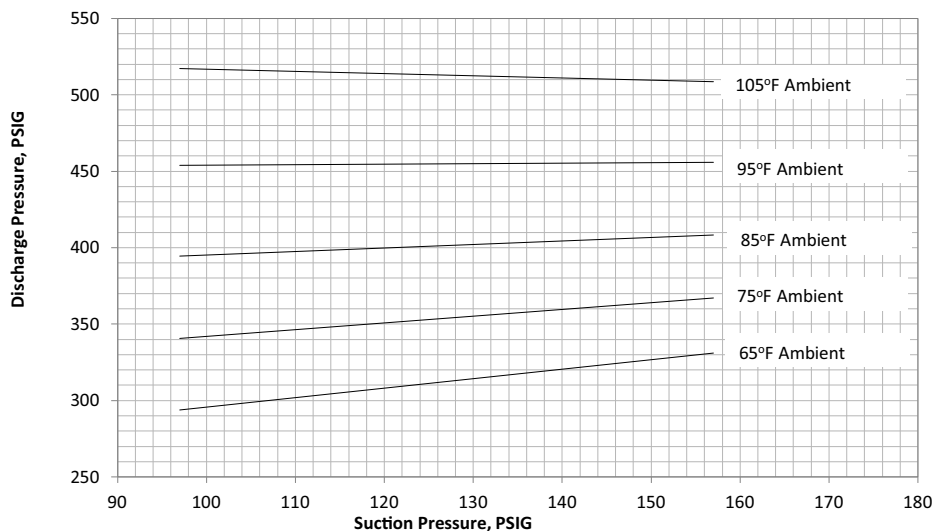


**Figure 92. 150 ton eFlex variable speed—circuit 1 and circuit 2 operating pressure curve (compressor at 100% and all condenser fans ON) (standard capacity)**

### 150 Ton eFlex Circuit 1, 50Hz



### 150 Ton eFlex Circuit 2, 50Hz



## Components

### Economizer and Exhaust Air Damper Adjustment

#### Exhaust Air Dampers

Verify that the exhaust dampers (if equipped) close tightly when the unit is off. Adjust the damper linkage as necessary to ensure proper closure. An access panel is provided under each damper assembly.

### Outside Air and Return Air Damper Operation

The outside air and return air damper linkage is accessible from the filter section of the unit. The damper linkage connecting the outside air dampers to the return air dampers is preset from the factory in the number 1 position. Refer to [Figure 93, p. 139](#) for the appropriate linkage position for the unit and operating airflow (CFM).



**⚠ WARNING**

**No Step Surface!**

Failure to follow instruction below could result in death or serious injury.

Do not walk on the sheet metal drain pan. Walking on the drain pan could cause the supporting metal to collapse and result in the operator/technician falling.

*Note: Bridging between the unit main supports may consist of multiple 2 x 12 boards or sheet metal grating.*

Arbitrarily adjusting the outside air dampers to open fully when the return air dampers are closed or; failing to maintain the return air pressure drop with the outside air dampers when the return air dampers are closed, can overload the supply fan motor and cause building pressurization control problems due to improper CFM being delivered to the space.

The outside air/return air damper linkage is connected to a crank arm with a series of holes that allows the installer or operator to modify the amount of outside air damper travel in order to match the return static pressure.

Refer to [Table 51, p. 139](#) for the equivalent return air duct losses that correspond to each of the holes illustrated in [Figure 93, p. 139](#).

**To Adjust the Outside Air Damper Travel**

1. Drill a 1/4" hole through the unit casing up stream of the return air dampers. Use a location that will produce an accurate reading with the least amount of turbulence – several locations may be necessary, then average the reading.

**⚠ WARNING**

**Hazardous Voltage!**

Failure to disconnect power before servicing could result in death or serious injury.

Disconnect all electric power, including remote disconnects before servicing. Follow proper lockout/tagout procedures to ensure the power can not be inadvertently energized. Verify that no power is present with a voltmeter.

**Important: HIGH VOLTAGE IS PRESENT AT TERMINAL BLOCK OR UNIT DISCONNECT SWITCH.**

2. Close the disconnect switch or circuit protector switch that provides the supply power to the unit terminal block or the unit mounted disconnect switch.
3. Turn the 115 volt control circuit switch and the 24 volt control circuit switch to the On position.
4. Open the access door located in the unit control panel, and press the Manual Override key to display the first service screen. Refer to the latest edition of the applicable programming manual for applications for the Manual Override screens and programming instructions.

5. With the outside air dampers fully closed and the supply fan operating at 100% airflow requirements, measure the return static pressure at the location determined in step 1.
6. Press the STOP key in the unit control panel to stop the fan operation.

**⚠ WARNING**

**Live Electrical Components!**

Failure to follow all electrical safety precautions when exposed to live electrical components could result in death or serious injury.

When it is necessary to work with live electrical components, have a qualified licensed electrician or other individual who has been properly trained in handling live electrical components perform these tasks.

**⚠ WARNING**

**Rotating Components!**

Failure to disconnect power before servicing could result in rotating components cutting and slashing technician which could result in death or serious injury.

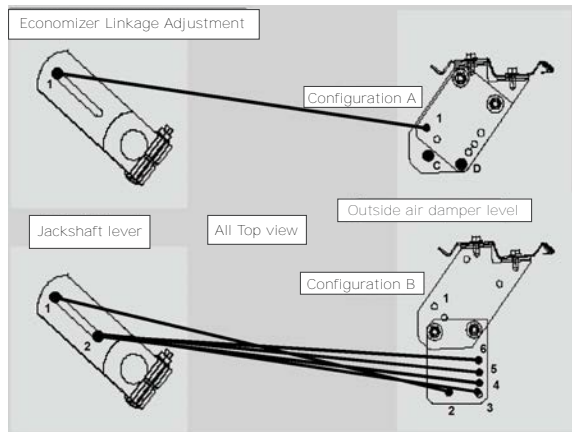
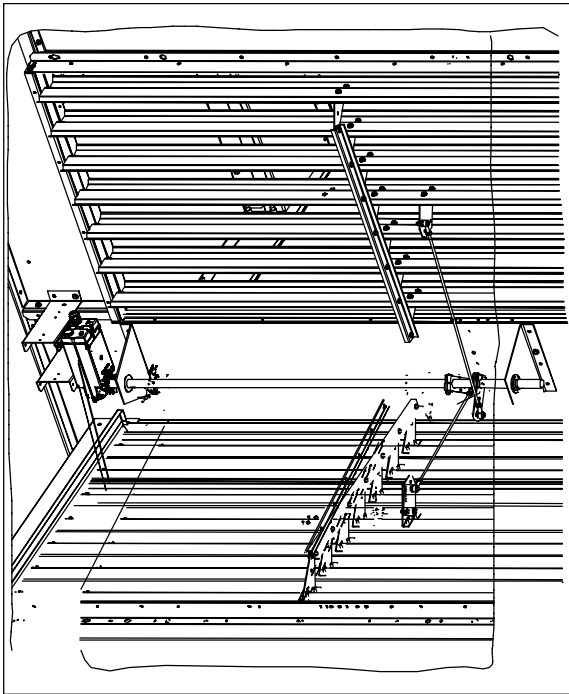
Disconnect all electric power, including remote disconnects before servicing. Follow proper lockout/tagout procedures to ensure the power can not be inadvertently energized.

7. Open the field supplied main power disconnect switch upstream of the rooftop unit. Lock the disconnect switch in the "Open" position while working on the dampers.  
*Note: Gravity will cause the damper to close. Support or secure the damper blades while removing the actuator to prevent unexpected damper rotation.*
8. Compare the static pressure reading to the static pressure ranges and linkage positions in [Table 51, p. 139](#) for the unit size and operating CFM.  
Relocate the outside air/return air connecting rod to balance the outside air damper pressure drop against the return static pressure, using the following steps. If no adjustment is necessary, proceed to step 17.
9. Remove the drive rod and swivel from the crank arm(s). If only one hole requires changing, loosen only that end.
10. Manually open the return air dampers to the full open position.
11. Manually close the outside air dampers.
12. Reattach the drive rod and swivel to the appropriate hole(s). The length of the drive rod may need to be adjusted to align with the new hole(s) location. If so, loosen the lock nut on the drive rod against the swivel. Turn the swivel "in" or "out" to shorten or lengthen the rod as necessary. For some holes, both ends of the rod

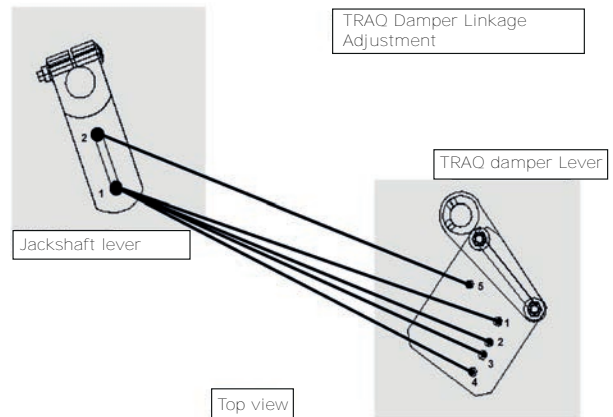
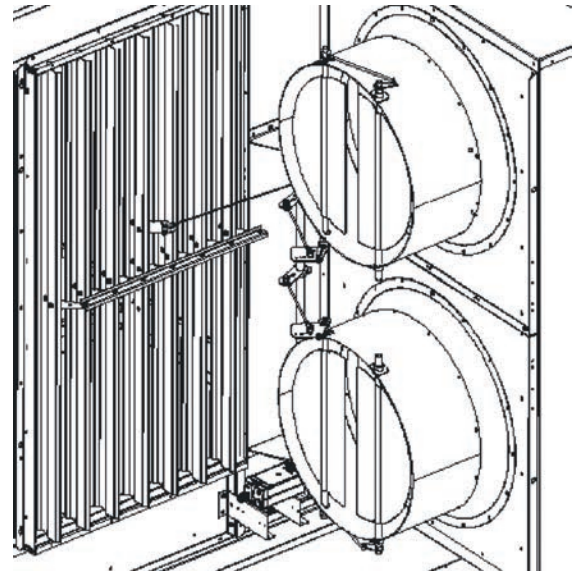
may need to be adjusted.

13. Tighten the lock nut against the swivel(s).
14. Plug the holes after the proper CFM has been established.

**Figure 93. Outside air and return air damper assembly**



**Figure 94. Outside air and return air economizer assembly (with Traq™ dampers)**



**Table 51. Standard unit (no ERW) (economizer) outside air damper travel adjustment/ pressure drop (inches w.c.)**

Economizer Linkage Set-up	Damper Position					
	1	2	3	4	5	6
Economizer Linkage Set-up	1	2	3	4	5	6
Jackshaft rod end location	1	1	2	2	2	2
Damper lever configuration	A	B	B	B	B	B
Damper lever rod end location	1	2	3	4	5	6
<b>120-162 Ton w/Economizer (includes mist eliminator)</b>						
CFM	Pressure Drop (inches w.c.)					
58,500	0.80	1.64	2.96	-	-	-
54,000	0.68	1.40	2.52	-	-	-



## Unit Startup

**Table 51. Standard unit (no ERW) (economizer) outside air damper travel adjustment/pressure drop (inches w.c.) (continued)**

45,500	0.48	0.99	1.79	2.22	2.62	-
42,000	0.41	0.85	1.53	1.89	2.23	2.69
38,000	0.34	0.69	1.25	1.55	1.83	2.20
34,000	0.27	0.56	1.00	1.24	1.46	1.76
30,000	0.21	0.43	0.78	0.97	1.14	1.37
<b>90-118 Ton w/Economizer (includes mist eliminator)</b>						
<b>CFM</b>	<b>Pressure Drop (inches w.c.)</b>					
47,250	0.81	1.88	-	-	-	-
40,500	0.60	1.39	2.62	-	-	-
36,750	0.49	1.14	2.16	2.71	-	-
31,500	0.36	0.84	1.59	1.99	2.36	2.87
28,000	0.28	0.66	1.25	1.57	1.87	2.27
25,000	0.22	0.53	1.00	1.25	1.49	1.81
23,000	0.19	0.45	0.85	1.06	1.26	1.53
<b>Damper Position</b>						
Jackshaft rod end location	1	1	1	2	1	
Damper lever rod end location	1	2	3	5	4	
Jackshaft rod end location	1	1	1	2	1	
<b>120-162 Ton w/Traq™ Damper (includes mist eliminator)</b>						
<b>CFM</b>	<b>Pressure Drop (inches w.c.)</b>					
58,500	1.10	1.52	2.16	2.73		
54,000	0.93	1.28	1.83	2.33		
45,500	0.64	0.89	1.28	1.64	2.14	
42,000	0.54	0.75	1.09	1.40	1.83	
38,000	0.44	0.60	0.88	1.14	1.50	
34,000	0.35	0.47	0.69	0.90	1.20	
30,000	0.27	0.35	0.53	0.69	0.93	
<b>90-118 Ton w/Traq™ Damper (includes mist eliminator)</b>						
<b>CFM</b>	<b>Pressure Drop (inches w.c.)</b>					
47,250	1.37	1.89	2.72			
40,500	0.99	1.35	1.97	2.54		
36,750	0.80	1.09	1.60	2.08	2.74	
31,500	0.58	0.77	1.15	1.51	2.01	
28,000	0.46	0.59	0.89	1.17	1.58	
25,000	0.37	0.45	0.69	0.92	1.24	
23,000	0.31	0.37	0.57	0.76	1.04	

## Standard Unit with Energy Recovery Wheel

### Economizer Damper Adjustment - ERW units

#### Outside & Return Air Damper Operation

The outside air and return air damper actuators are accessible through from the filter section of the unit. The outside air and return air dampers have individual actuators that are linked electronically. The actuators are preset to 0 degrees from the factory. Refer to "Table 46, p. 170," for the appropriate actuator position for the unit and operating airflow (CFM).

#### To Adjust the Outside Air Damper Travel

1. Drill a 1/4" hole through the unit casing up stream of the return air dampers and below the energy recovery wheel. Use a location that will produce an accurate reading with the least amount of turbulence. Several locations may be necessary, and average the reading.

### **⚠ WARNING**

#### **Hazardous Voltage!**

**Failure to disconnect power before servicing could result in death or serious injury.**

**Disconnect all electric power, including remote disconnects before servicing. Follow proper lockout/tagout procedures to ensure the power can not be inadvertently energized. Verify that no power is present with a voltmeter.**

**Important: HIGH VOLTAGE IS PRESENT AT TERMINAL BLOCK OR UNIT DISCONNECT SWITCH.**

2. Close the disconnect switch or circuit protector switch that provides the supply power to the unit terminal block or the unit mounted disconnect switch.
3. Turn the 115 volt control circuit switch and the 24 volt control circuit switch to the "On" position.
4. Open the user interface access door, located in the unit control panel, and use the Manual override to operate the Supply fan and Outdoor air damper position.
5. Once the configuration for the components is complete, press the NEXT key until the LCD displays the "Start test in \_\_Sec." screen. Press the + key to designate the delay before the test is to start. This service test will begin after the TEST START key is pressed and the delay designated in this step has elapsed. Press the ENTER key to confirm this choice.

## ⚠ WARNING

### Rotating Components!

Failure to disconnect power before servicing could result in rotating components cutting and slashing technician which could result in death or serious injury.

Disconnect all electric power, including remote disconnects before servicing. Follow proper lockout/tagout procedures to ensure the power can not be inadvertently energized.

6. With the outside air dampers fully closed and the supply fan operating at 100% airflow requirements, measure the return static pressure at the location determined in step 1.
7. Press the STOP key at the user interface in the unit control panel to stop the fan operation.
8. Open the field supplied main power disconnect switch upstream of the rooftop unit. Lock the disconnect switch in the "Open" position while working on the dampers.
9. Locate the static pressure reading in "Table 46, p. 170," and determine which damper needs to be adjusted and the degree reading. Proceed to the appropriate damper actuator procedure.

### To Adjust the Outside Air Damper Actuators

1. Remove the shaft coupling from the damper shaft by loosening the bolt and removing the retainer clip. Be careful not to rotate the shaft.
2. Position the shaft coupling so that the indicator points to the degree value obtained from Step 9. The shaft coupling is adjustable in 5 degree increments.
3. Replace the retainer clip and tighten the shaft coupling on the shaft (120-180 in-lbs).
4. Close the disconnect switch or circuit protector switch that provides the supply power to the unit terminal block or the unit mounted disconnect switch.
5. Rotate the actuator control signal dial to Auto-Adapt.

The actuator will drive open and then closed to determine the new open and closed positions.

6. Return the actuator control signal dial to 2-10 VDC Modulating input signal position.
7. Plug the holes drilled in the cabinet after the proper airflow has been established.

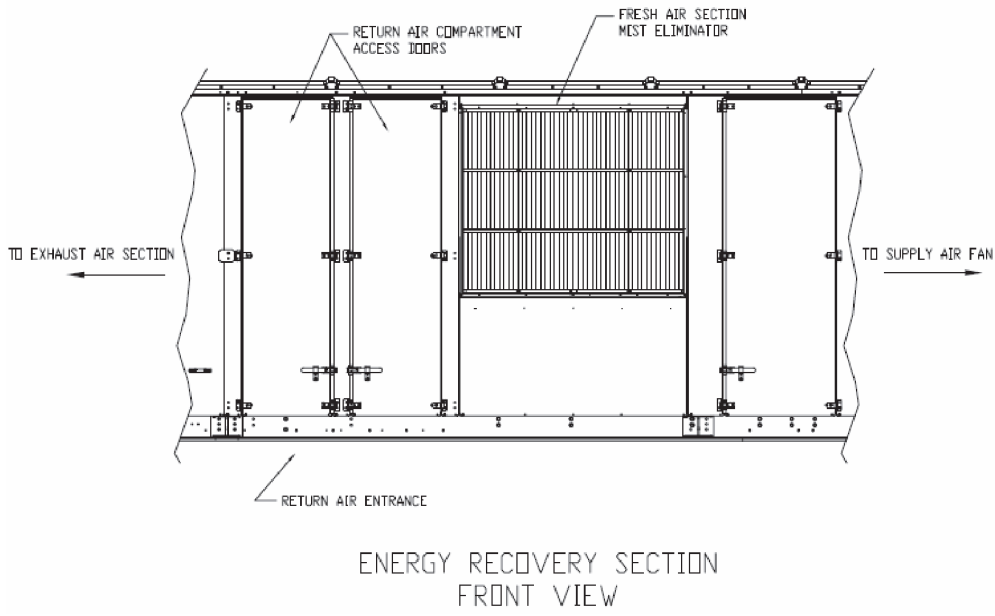
### To Adjust the Return Damper Actuators

1. Support or secure the damper blades in the wide open position.

**Note:** Gravity will cause the damper to close. Support or secure the damper blades while removing the actuator to prevent unexpected damper rotation.

2. Do not remove the shaft coupling from the shaft. Remove the retainer clip from the shaft coupling.
3. Unscrew the actuator bracket from the damper wall.
4. Slide the actuator down the damper shaft off of the shaft coupling.
5. Rotate the actuator and reinstall the shaft coupling in the actuator so that the indicator points to the degree value obtained in Step 11. The shaft coupling is adjustable in 5 degree increments.
6. Replace the retainer clip and remove the blade stops to allow the blades to rotate.
7. Rotate the actuator to the original position and reattach the actuator bracket to the damper wall.
8. Close the disconnect switch or circuit protector switch that provides the supply power to the unit terminal block or the unit mounted disconnect switch.
9. Rotate the actuator control signal dial to Auto-Adapt. The actuator will drive open and then closed to determine the new open and closed positions.
10. Return the actuator control signal dial to the factory set input signal position.
11. Plug the holes drilled in the cabinet after the proper airflow has been established.

**Figure 95. IntelliPak 2 energy wheel section**



**Table 52. Standard units with ERW — field measured plenum pressure — Low CFM ERW — 90- 150 Tons**

CFM		90 Ton Low CFM ERW - Field measured plenum pressure (inches wc)												105 Ton Low CFM ERW - Field measured plenum pressure (inches wc)												120 Ton Low CFM ERW - Field measured plenum pressure (inches wc)																																																																																																														
		OA Actuator Reading [Degrees]						RA Actuator Reading [Degrees]						OA Actuator Reading [Degrees]						RA Actuator Reading [Degrees]						OA Actuator Reading [Degrees]						RA Actuator Reading [Degrees]																																																																																																								
		60		50		40		30		20		10		0		10		20		30		40		50		60		50		40		30		20		10		0		10		20		30		40		50																																																																																								
Econ	TRAQ	Econ	TRAQ	Econ	TRAQ	Econ	TRAQ	Econ	TRAQ	Econ	TRAQ	Econ	TRAQ	Econ	TRAQ	Econ	TRAQ	Econ	TRAQ	Econ	TRAQ	Econ	TRAQ	Econ	TRAQ	Econ	TRAQ	Econ	TRAQ	Econ	TRAQ	Econ	TRAQ	Econ	TRAQ	Econ	TRAQ	Econ	TRAQ	Econ	TRAQ	Econ	TRAQ	Econ	TRAQ	Econ	TRAQ																																																																																									
16000	1.29	—	1.52	0.87	1.52	0.71	1.05	0.64	0.84	0.6	0.64	0.58	0.63	0.46	0.45	0.43	0.41	0.38	0.35	0.32	0.2	20000	1.99	—	1.34	1.09	1.62	0.98	1.28	0.92	0.97	0.89	0.96	0.69	0.68	0.65	0.62	0.57	0.52	0.48	0.29	25000	—	—	1.68	2.49	1.5	1.97	1.41	1.49	1.36	1.47	1.04	1.02	0.99	0.93	0.86	0.78	0.71	0.42	30000	—	—	2.94	—	2.13	2.79	1.99	2.09	1.93	2.08	1.46	1.43	1.37	1.3	1.19	1.08	0.98	0.56	33000	—	—	—	—	2.54	—	2.38	2.5	2.3	2.48	1.73	1.7	1.63	1.54	1.41	1.28	1.15	0.65	36000	—	—	—	—	3	—	2.8	2.94	2.71	2.92	2.02	1.98	1.91	1.79	1.64	1.48	1.34	0.74	40000	—	—	—	—	—	—	—	—	—	—	2.46	2.41	2.32	2.18	1.98	1.79	1.61	0.87



Unit Startup

**Table 52. Standard units with ERW — field measured plenum pressure — Low CFM ERW — 90- 150 Tons (continued)**

CFM		130-150 Ton Low CFM ERW - Field measured plenum pressure (inches wc)																							
		OA Actuator Reading [Degrees]						RA Actuator Reading [Degrees]																	
		60		50		40		30		20		10		0		10		20		30		35		40	
Econ	TRAQ	Econ	TRAQ	Econ	TRAQ	Econ	TRAQ	Econ	TRAQ	Econ	TRAQ	Econ	TRAQ	Econ	TRAQ	Econ	TRAQ	E/T	E/T	E/T	E/T	E/T	E/T	E/T	E/T
23000	1.82	—	1.27	—	1.06	1.27	1.6	1.33	1.06	0.91	1.02	0.89	0.87	0.67	0.65	0.62	0.57	0.65	0.62	0.57	0.51	0.44	0.39	—	—
26000	2.31	—	1.6	—	1.33	1.6	1.32	1.14	1.28	1.11	1.09	1.09	0.83	0.81	0.77	0.71	0.63	0.81	0.77	0.71	0.63	0.54	0.47	—	—
30000	—	—	2.1	—	1.74	2.09	1.57	1.49	1.67	1.44	1.41	1.41	1.06	1.03	0.98	0.9	0.79	1.03	0.98	0.9	0.79	0.69	0.59	—	—
35000	—	—	2.8	—	2.32	2.79	2.09	1.97	2.22	1.91	1.87	1.87	1.39	1.36	1.29	1.18	1.03	1.36	1.29	1.18	1.03	0.88	0.75	—	—
40000	—	—	—	—	2.97	—	2.68	2.52	2.84	2.45	2.39	2.39	1.77	1.72	1.62	1.48	1.29	1.72	1.62	1.48	1.29	1.1	0.92	—	—
45000	—	—	—	—	—	—	—	—	—	—	2.96	—	2.17	2.11	1.99	1.81	1.57	2.17	1.99	1.81	1.57	1.33	1.1	—	—
50000	—	—	—	—	—	—	—	—	—	—	—	—	—	2.62	2.54	2.39	2.17	2.62	2.54	2.39	2.17	1.87	1.57	1.3	—
55000	—	—	—	—	—	—	—	—	—	—	—	—	—	3.09	3	2.82	2.56	3.09	3	2.82	2.56	2.2	1.83	1.5	—
58000	—	—	—	—	—	—	—	—	—	—	—	—	—	3.4	3.29	3.1	2.8	3.4	3.29	3.1	2.8	2.4	1.99	1.62	—



**Table 53. Standard units with ERW — field measured plenum pressure — Standard CFM ERW — 90-150 Tons**

CFM		90/100 Ton Standard CFM ERW - Field measured plenum pressure (inches wc)												105 Ton Standard CFM ERW - Field measured plenum pressure (inches wc)												120 Ton Standard CFM ERW - Field measured plenum pressure (inches wc)																																																																																																																
		OA Actuator Reading [Degrees]						RA Actuator Reading [Degrees]						OA Actuator Reading [Degrees]						RA Actuator Reading [Degrees]						OA Actuator Reading [Degrees]						RA Actuator Reading [Degrees]																																																																																																										
		60		50		40		30		20		10		0		10		20		30		40		50		60		50		40		30		20		10		0		10		20		30		40		50																																																																																										
Econ	TRAQ	Econ	TRAQ	Econ	TRAQ	Econ	TRAQ	Econ	TRAQ	Econ	TRAQ	Econ	TRAQ	Econ	TRAQ	Econ	TRAQ	Econ	TRAQ	Econ	TRAQ	Econ	TRAQ	Econ	TRAQ	Econ	TRAQ	Econ	TRAQ	Econ	TRAQ	Econ	TRAQ	Econ	TRAQ	Econ	TRAQ	Econ	TRAQ	Econ	TRAQ	Econ	TRAQ	Econ	TRAQ	Econ	TRAQ																																																																																											
16000	1.26	0.84	1.49	0.68	1.02	0.81	0.81	0.57	0.61	0.55	0.6	0.43	0.42	0.4	0.38	0.35	0.32	0.29	0.17	20000	1.95	1.3	2.3	1.05	1.57	0.93	1.24	0.88	0.93	0.85	0.92	0.64	0.63	0.61	0.57	0.52	0.48	0.25	25000		2		1.62	2.42	1.43	1.9	1.34	1.42	1.3	1.41	0.97	0.95	0.92	0.86	0.79	0.71	0.64	0.35	30000		2.84		2.28		2.02	2.69	1.89	1.99	1.82	1.97	1.35	1.32	1.27	1.19	1.08	0.97	0.87	0.46	33000				2.74		2.42		2.26	2.38	2.18	2.36	1.61	1.58	1.51	1.42	1.29	1.16	1.03	0.53	36000						2.86		2.67	2.81	2.57	2.78	1.89	1.85	1.77	1.66	1.5	1.35	1.2		40000												2.28	2.23	2.14	2	1.81	1.61	1.44	



**Table 53. Standard units with ERW — field measured plenum pressure — Standard CFM ERW — 90-150 Tons (continued)**

CFM		130-150 Ton Standard CFM ERW - Field measured plenum pressure (inches wc)																					
		OA Actuator Reading [Degrees]						RA Actuator Reading [Degrees]															
		60		50		40		30		20		10		0		10		20		30		40	
Econ	TRAQ	Econ	TRAQ	Econ	TRAQ	Econ	TRAQ	Econ	TRAQ	Econ	TRAQ	Econ	TRAQ	Econ	TRAQ	E/T	E/T	E/T	E/T	E/T	E/T	E/T	E/T
23000	1.73		1.18	1.92	0.97	1.18	1.48	1.18	0.87	0.96	0.82	0.93	0.8	0.78	0.58	0.56	0.53	0.48	0.42	0.35	0.3		
26000	2.19		1.49	2.43	1.22	1.48	1.22	1.09	1.2	1.03	1.16	1	0.97	0.71	0.69	0.65	0.59	0.51	0.43	0.35			
30000	2.89		1.95		1.59	1.94	1.42	1.56	1.52	1.34	1.52	1.29	1.26	0.91	0.88	0.83	0.75	0.64	0.54	0.44			
35000			2.59		2.11	2.58	1.88	2.07	1.76	2.01	1.71	1.66	1.19	1.15	1.08	0.97	0.82	0.67					
40000					2.71		2.41	2.66	2.26	2.57	2.18	2.12	1.5	1.45	1.36	1.22	1.02	0.83					
45000							3		2.8		2.71	2.63	1.84	1.78	1.66	1.49	1.24	1					
50000														2.23	2.15	2.01	1.79	1.49	1.19				
55000														2.65	2.55	2.38	2.11	1.75					
58000														2.91	2.8	2.61	2.31	1.91					

### Energy Recovery Wheel (ERW)

The IntelliPak™ 2 energy wheel section consists of the energy wheel cassette assembly, return air, outside air, and bypass dampers, and outside air mist eliminators. Double opposing large access doors are provided on both sides of

the section for service access into the return/exhaust air compartment, see “Figure 125,” p. 142.

### ⚠ WARNING

#### Toxic Hazards!

Failure to follow instructions below could result in death or serious injury.  
 Do not use an energy wheel in an application where the exhaust air is contaminated with harmful toxins or biohazards.

The two access doors are accessible from either side of the rooftop. The horizontally oriented energy wheel cassette is permanently installed in the section. The individual segments of the energy wheel are removable for cleaning or replacement. Two additional access doors are provided for service access into the filter / evaporator section.

#### Operation

### NOTICE

#### Energy Wheel Motor Failure!

Failure to follow instructions below could result in failure of the energy wheel motor  
 Do not install a variable frequency drive (VFD) to control the energy wheel speed.

### ⚠ WARNING

#### Confined Space Hazards!

Failure to follow instructions below could result in death or serious injury.  
 Do not work in confined spaces where refrigerant or other hazardous, toxic, or flammable gas may be leaking. Refrigerant or other gases could displace available oxygen to breathe, causing possible asphyxiation or other serious health risks. Some gases may be flammable and/or explosive. If a leak in such spaces is detected, evacuate the area immediately and contact the proper rescue or response authority.

### ⚠ WARNING

#### Hazardous Voltage!

Failure to disconnect power before servicing could result in death or serious injury.  
 Disconnect all electric power, including remote disconnects before servicing. Follow proper lockout/tagout procedures to ensure the power can not be inadvertently energized. Verify that no power is present with a voltmeter.

### ⚠ WARNING

#### Rotating Components!

Failure to disconnect power before servicing could result in rotating components cutting and slashing technician which could result in death or serious injury.

During installation, testing, servicing and troubleshooting of this product it may be necessary to work with live and exposed rotating components. Have a qualified or licensed service individual who has been properly trained in handling exposed rotating components, perform these tasks.

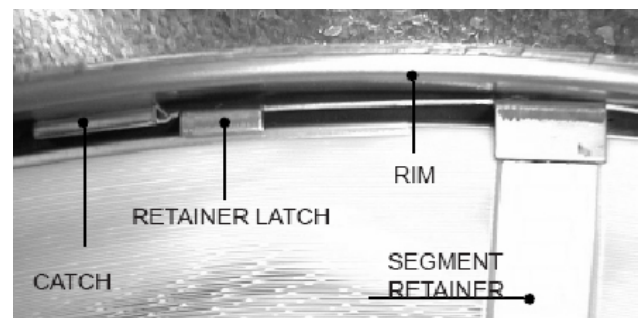
### ⚠ WARNING

#### Rotating Components!

Failure to disconnect power before servicing could result in rotating components cutting and slashing technician which could result in death or serious injury.

Disconnect all electric power, including remote disconnects before servicing. Follow proper lockout/tagout procedures to ensure the power can not be inadvertently energized.

Figure 96. Segment retainers



#### ERW Startup

1. Turn the energy wheel clockwise (as viewed from the pulley side) by hand to verify that the wheel turns freely through a full rotation.
2. Confirm that all wheel segments are fully engaged in the wheel frame and that the segment retainers are completely fastened. See Figure 97, p. 149.
3. Manually rotate the energy wheel clockwise through several rotations to confirm the seal adjustment and proper belt tracking on the wheel rim. Correct belt tracking is approximately midway between the seal plate and the outer edge of the rim.



## Unit Startup

**Note:** The drive belt is a urethane stretch belt designed to provide constant tension throughout the life of the belt. No periodic adjustment is required. Inspect the belt annually for proper tracking and tension. A properly tensioned belt will turn the wheel immediately, with no visible slippage, when power is applied.

- If the wheel has difficulty starting, turn off the power and inspect the wheel for excessive interference between the wheel surface and the four diameter seals. To correct interference, loosen the diameter seal adjusting screws and back the diameter seals away from the surface of the wheel. Apply power to confirm free wheel rotation. Re-adjust and tighten the seals according to instructions in the "Service and Repair" section.

### Damper Actuators

Stroke the actuators to observe full open and full closure of the dampers.

### Routine Maintenance

#### NOTICE

##### Energy Wheel Damage!

Failure to follow instructions below could result in wheel damage.

Do not use acid based cleaners, aromatic solvents, steam, or temperatures in excess of 170°F to clean the wheel.

Do not use a pressure washer to clean energy wheel segments.

### Cleaning the Energy Wheel

Disconnect all electrical power, then use a vacuum or brush to remove accumulated material from the face of the wheel. Examine the energy wheel monthly for material build-up on the wheel. If more aggressive cleaning is needed, removed the wheel segments and follow these steps:

- Wash the segments or the wheel in a five-percent solution of non-acid-base coil cleaner (part no. CHM00021 at your local Trane parts center) or in an alkaline detergent and warm water.
- Soak the segments in the solution until grease, oil, and tar deposits are loosened.
- Before removing the cleaner, rapidly run your fingers across the surface of segments to separate polymer strips for better cleaning action.
- Rinse the dirty solution from the segments and remove the excess water before re-installing the segments in the wheel.

**Note:** Some permanent staining of the desiccant may remain but is not harmful to performance.

### Cleaning Frequency

In reasonably clean office or school buildings, cleaning with a coil cleaner solution may not be required for several years. If the energy wheel is exposed to air streams containing, for example, high levels of occupant tobacco smoke, cooking facility exhaust air, or oil-based aerosols found in machine shop areas, annual or more frequent cleaning may be required to remove these contaminants and restore performance. Periodic inspection of the wheel should be done to determine the cleaning intervals.

#### ⚠ WARNING

##### Hazardous Voltage!

Failure to disconnect power before servicing could result in death or serious injury.

Disconnect all electric power, including remote disconnects before servicing. Follow proper lockout/tagout procedures to ensure the power can not be inadvertently energized. Verify that no power is present with a voltmeter.

#### ⚠ WARNING

##### Rotating Components!

Failure to disconnect power before servicing could result in rotating components cutting and slashing technician which could result in death or serious injury.

During installation, testing, servicing and troubleshooting of this product it may be necessary to work with live and exposed rotating components. Have a qualified or licensed service individual who has been properly trained in handling exposed rotating components, perform these tasks.

High-maintenance applications may benefit from keeping a spare set of clean segments on hand. This allows for rapid change-out of clean segments with minimal downtime. The dirty segments can then be cleaned at a convenient time.

### Segment Removal

#### ⚠ WARNING

##### Hazardous Voltage!

Failure to disconnect power before servicing could result in death or serious injury.

Disconnect all electric power, including remote disconnects before servicing. Follow proper lockout/tagout procedures to ensure the power can not be inadvertently energized. Verify that no power is present with a voltmeter.

**Important:** Do not open the service access doors while the unit is operating.

Wheel segments for the low CFM energy recovery option for the 90, 105, and 120 ton units are secured to the wheel frame by a segment retainer that pivots on the wheel rim and is held in place by a segment retaining catch. All other

units have larger sized wheels and have inner and satellite segments. The satellite segments are secured to the wheel frame by a segment retainer in the same fashion as the outer segments for the above mentioned smaller low CFM recovery wheels. The inner segments are secured to the wheel center hub with a screw.

**Outer and Satellite Segment Removal Procedure**

1. Disconnect all electrical power.
2. Secure wheel from rotation.
3. Pry the segment retainer latch out from the catch. See [Figure 97, p. 149](#). For the first or for an individual segment removal, it will be necessary to do so on both sides of the segment.
4. Remove the forked segment retainer(s). See [Figure 97, p. 149](#). Again, for the first or for an individual segment removal, it will be necessary to do so on both sides of the segment.
5. Remove the segment from the wheel frame. It may be necessary to gently pry the segment out of the wheel with a screwdriver.
6. Pull the segment up and out of the wheel frame.
7. Close any open segment retainer prior to rotating the wheel. Failure to close the retainer may damage the retainer, seals, or segments.
8. Rotate the wheel and continue this procedure to remove all segments. See [Figure 98, p. 149](#).

**Figure 97. Segment Retainers**



**Figure 98. Segment Removal**



**⚠ WARNING**

**Rotating Components!**  
 Failure to disconnect power before servicing could result in rotating components cutting and slashing technician which could result in death or serious injury.  
 Disconnect all electric power, including remote disconnects before servicing. Follow proper lockout/tagout procedures to ensure the power can not be inadvertently energized.

**⚠ WARNING**

**Hazardous Voltage!**  
 Failure to disconnect power before servicing could result in death or serious injury.  
 Disconnect all electric power, including remote disconnects before servicing. Follow proper lockout/tagout procedures to ensure the power can not be inadvertently energized. Verify that no power is present with a voltmeter.

**Inner Segment Removal Procedure:**

1. Disconnect all electrical power.
2. Secure wheel from rotation.

**⚠ CAUTION**

**Sharp Edges!**  
 Failure to follow instructions below could result in minor to moderate injury.  
 The service procedure described in this document involves working around sharp edges. To avoid being cut, technicians **MUST** put on all necessary Personal Protective Equipment (PPE), including gloves and arm guards.

### ⚠ WARNING

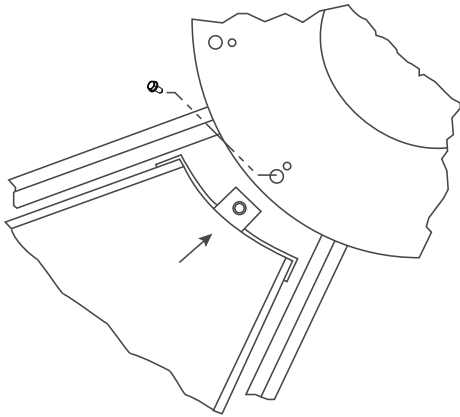
#### Risk of Energy Wheel Collapsing!

Failure to follow instructions below could cause the energy wheel to collapse under the technician's weight which could result in severe injury.

Before laying across the energy wheel, add extra support by placing a rigid board across the span of the energy wheel cassette.

- Support segment with one hand while removing 1/4 - 20 flat head retaining screw in the wheel hub with 5/32" Allen wrench, see [Figure 99, p. 150](#).

**Figure 99. Inner Segment Removal**



- Carefully slide the segment out from between the hub plates, and remove from the wheel.
- Reinsert the 1/4 - 20 screw in the removed segment nose to avoid loss.
- Rotate the wheel and continue this procedure to remove all segments.

#### Segment Replacement

### ⚠ WARNING

#### Hazardous Voltage!

Failure to disconnect power before servicing could result in death or serious injury.

Disconnect all electric power, including remote disconnects before servicing. Follow proper lockout/tagout procedures to ensure the power can not be inadvertently energized. Verify that no power is present with a voltmeter.

#### Inner Segment Replacement

- Disconnect all electrical power.
- Secure wheel from rotation.

### ⚠ CAUTION

#### Sharp Edges!

Failure to follow instructions below could result in minor to moderate injury.

The service procedure described in this document involves working around sharp edges. To avoid being cut, technicians **MUST** put on all necessary Personal Protective Equipment (PPE), including gloves and arm guards.

- Remove 1/4 - 20 flat head retaining screw from the inner segment nose with 5/32" Allen wrench.
- Rest the edge of the segment on the support flange on one wheel spoke and slide it until the segment nose is fitted firmly in the wheel hub and the segment screw hole is aligned with the hub slot.
- Reinsert 1/4 - 20 screw into the hub / inner segment and tighten until the screw is firmly seated, see [Figure 99, p. 150](#).

#### Outer or Satellite Segment Replacement

### ⚠ WARNING

#### Hazardous Voltage!

Failure to disconnect power before servicing could result in death or serious injury.

Disconnect all electric power, including remote disconnects before servicing. Follow proper lockout/tagout procedures to ensure the power can not be inadvertently energized. Verify that no power is present with a voltmeter.

### ⚠ WARNING

#### Rotating Components!

Failure to disconnect power before servicing could result in rotating components cutting and slashing technician which could result in death or serious injury.

Disconnect all electric power, including remote disconnects before servicing. Follow proper lockout/tagout procedures to ensure the power can not be inadvertently energized.

- Disconnect all electrical power.
- Secure wheel from rotation.
- Rotate out the two segment retainer latches, one for each side of the selected segment opening, such that they are 90° from the wheel rim. See [Figure 99, p. 150](#).
- Set the segment in the gap between the segment retainer latches, pressing it toward the center of the wheel and inward against the spoke flanges. See [Figure 102, p. 152](#). If hand pressure does not fully seat the segment, insert the flat tip of a screwdriver between the wheel rim and the outer corners of the segment and apply gentle force while guiding the segment into place. Be careful not to bend the wheel frame or the segment

frame with the screwdriver.

- Reinstall forked segment retainer(s)

**Note:** Only applies when there is an adjacent segment in place.

- Close each segment retainer latch under the segment retaining catch.
- Rotate the wheel and repeat this sequence with the remaining segments.

Removing and replacing the segments with a spare set can be accomplished more quickly. Remove the dirty segment, replace it with a clean segment, then move to the next segment.

### Filtration

#### **⚠ WARNING**

##### **Hazardous Voltage!**

Failure to disconnect power before servicing could result in death or serious injury.

Disconnect all electric power, including remote disconnects before servicing. Follow proper lockout/tagout procedures to ensure the power can not be inadvertently energized. Verify that no power is present with a voltmeter.

Galvanized steel permanent filters are provided to prevent debris from entering the energy wheel section. The return air filters are mounted in a filter rack underneath the energy recovery wheel, and are accessible from either side by means of the double access doors. The outside air filter rack is attached to the energy recovery cassette. Use the unit filter / evaporator coil access doors to service the energy recovery outside air filters.

- Disconnect all electrical power.
- Remove all filter media from the vertical filter rack providing air filtration for the unit evaporator coil.
- Remove the sheet metal screws in the hinged access panel beneath the bypass damper assembly.
- Rotate the access panel downwards.
- Reach in past the damper wall to access the flexible filter puller(s). Pull them towards the evaporator coil enough to reach the second filter in each slot of the filter rack. Refer to [Table 54, p. 151](#) for filter information.

**Table 54. ERW Filter Information**

Galvanized Steel Filter Info	90-105 Ton Low CFM ERW Units (in.)	90-150 Ton Low CFM ERW Units (in.)	90-150 Ton Standard CFM ERW Units (in.)
RA Filters (size, number)	24x24x1, 10	24x24x1, 10	24x24x1, 10
FA Filters (size, number)	224x24x1, 8	24x24x1, 6	24x24x1, 8
		12x24x1, 2	

**Note:** Inspect these filters monthly and clean them as necessary.

### Bearing and Motor Lubrication

The wheel drive motor and wheel support shaft bearings are permanently lubricated and no further lubrication is necessary.

### Service and Repair

#### Drive Belt Replacement

The drive belt is a urethane stretch belt designed to provide constant tension throughout the life of the belt. No periodic adjustment is required. Inspect the belt annually for proper tracking and tension. A properly tensioned belt will turn the wheel immediately, with no visible slippage, when power is applied.

#### **⚠ WARNING**

##### **Hazardous Voltage!**

Failure to disconnect power before servicing could result in death or serious injury.

Disconnect all electric power, including remote disconnects before servicing. Follow proper lockout/tagout procedures to ensure the power can not be inadvertently energized. Verify that no power is present with a voltmeter.

#### **⚠ WARNING**

##### **Risk of Energy Wheel Collapsing!**

Failure to follow instructions below could cause the energy wheel to collapse under the technician's weight which could result in severe injury.

Before laying across the energy wheel, add extra support by placing a rigid board across the span of the energy wheel cassette.

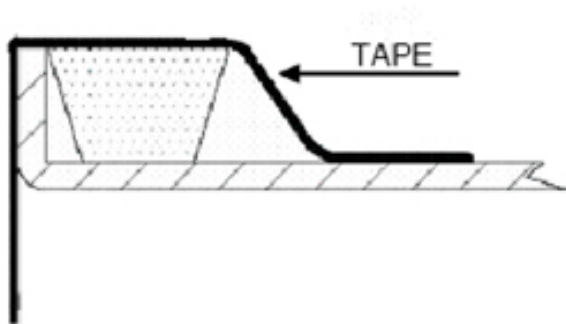
- Disconnect all electrical power.
- Confirm the model number on the belt replacement kit matches the model number on the label by the motor pulley. Remove all remnants of the old belt.
- Uncoil the belt as necessary. The belt must not twist when being feed around the wheel rim.
- At a location near the motor pulley, tape the hook end of the belt to the wheel rim, see [Figure 98, p. 149](#) and [Figure 102, p. 152](#). The tape should cover the hook and belt, see [Figure 100, p. 152](#).
- Manually rotate the wheel clockwise while feeding the belt onto the wheel rim, taking care that the belt does not twist.
 

**Note:** If for any reason the belt were to become flipped or twisted 90° in either direction, belt failure will be imminent.
- Upon feeding the belt completely through, remove the tape and join the link with the belt positioned around the wheel rim, see [Figure 101, p. 152](#). Keep light tension

on the belt, as a slack belt may be prone to twist.

7. Manually rotate the wheel clockwise until the linked belt ends are approximately 180° from the motor pulley location.
  8. Insert the right angle belt retainer from the replacement kit at the pulley location. Place it between the segment retainer latch pivot point and the wheel spoke, see [Figure 102](#), p. 152 (left of the spoke).
- Important:** To avoid release of the segment latch do not insert retainer on the other side of spoke.
9. Manually rotate the wheel counter-clockwise to position the belt retainer clip close to the center beam and diameter seals.
  10. In a section between the retainer clip and the motor pulley, remove the belt from the wheel rim and then place it over the pulley.
  11. Manually rotate the wheel clockwise until the belt is fully stretched around the wheel rim and motor pulley.
  12. Remove the belt retainer clip and manually rotate the wheel clockwise at least two full rotations while verifying the belt is not twisted on the wheel rim or as it enters the pulley(s).

**Figure 100. Link belt installation**



**Figure 101. Link belt installation**



**Figure 102. Retaining clip location**



**Note:** Pile seal brackets are fixed with a single screw to the cassette frame near the ends of the wheel bearing beam. Because the height of the belt link is slightly higher than that of the urethane belt, a rare interference may occur when it passes the seal bracket. If this occurs, remove the interfering bracket(s). No measurable change of performance will occur.



## Seal Adjustment

### ⚠ WARNING

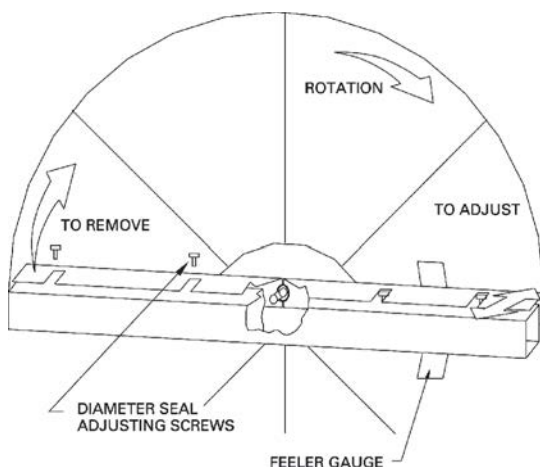
#### Hazardous Voltage!

Failure to disconnect power before servicing could result in death or serious injury.

Disconnect all electric power, including remote disconnects before servicing. Follow proper lockout/tagout procedures to ensure the power can not be inadvertently energized. Verify that no power is present with a voltmeter.

1. Disconnect all electrical power.
2. Loosen the diameter seal adjustment screws and back the seals away from the wheel surface, see [Figure 103, p. 153](#).
3. Rotate the wheel clockwise until two opposing spokes are hidden behind the bearing support beam.

**Figure 103. Wheel rotation**



4. Using a folded piece of paper as a feeler gauge, position the paper between the wheel surface and the diameter seals.
5. Adjust the seals toward the wheel surface until slight friction on the paper feeler gauge is felt when the gauge is moved along the length of the spoke.
6. Check the seal adjustment through a full rotation of the wheel. Re-tighten the adjusting screws and recheck the clearance with the paper-feeler gauge.

## Drive Motor and Pulley Replacement

### ⚠ WARNING

#### Hazardous Voltage!

Failure to disconnect power before servicing could result in death or serious injury.

Disconnect all electric power, including remote disconnects before servicing. Follow proper lockout/tagout procedures to ensure the power can not be inadvertently energized. Verify that no power is present with a voltmeter.

1. Disconnect all electrical power.
2. Remove the belt from the pulley and position it temporarily around the wheel rim.
3. Measure and record the distance from the inner edge of the pulley to the mounting wall.
4. Loosen the set screw in the wheel drive pulley using an Allen wrench and remove the pulley from the motor drive shaft.
5. While supporting the weight of the drive motor in one hand, loosen and remove the four mounting bolts.
6. Install a replacement motor with the hardware kit supplied.
7. Install the pulley and adjust it to the distance recorded earlier in this procedure.
8. Tighten the set screw to the drive shaft.
9. Stretch the belt over the pulley and engage it in the groove.

## Compressor Startup

### NOTICE

#### Compressor Failure!

Failure to follow instruction below could result in compressor failure.

**Unit must be powered and crankcase heaters energized at least 8 hours BEFORE compressors are started.**

1. Ensure that the "System" selection switch at the remote panel is in the "Off" position.
2. Before closing the disconnect switch, ensure that the compressor discharge service valve for each circuit is back seated.

### NOTICE

#### Compressor Damage!

Excessive liquid accumulation in the suction lines could result in compressor damage.

**Do not allow liquid refrigerant to enter the suction line.**



## Unit Startup

**Important:** COMPRESSOR SERVICE VALVES MUST BE FULLY OPENED BEFORE STARTUP (SUCTION, DISCHARGE, AND LIQUID LINE).

- Close the disconnect switch or circuit protector switch that provides the supply power to the unit terminal block or the unit mounted disconnect switch to allow the crankcase heater to operate a minimum of 8 hours before continuing.
- Turn the 115 volt control circuit switch and the 24 volt control circuit switch to the "On" position.

**Important:** Compressor Damage could occur if the crankcase heater is not allowed to operate the minimum of 8 hours before starting the compressor(s).

- Open the access door located in the unit control panel, and press Manual Overrides to display the first service screen. Refer to the latest edition of the applications programming guide (RT-SVP07\*-EN) for applications for the Manual Overrides screens and programming instructions.
- Use tables in "Voltage Imbalance," p. 93 to program the following system components for operation by scrolling through the displays.
- Attach a set of service gauges onto the suction and discharge gauge ports for each circuit. See Figure 104, p. 155 for the various compressor locations.

### **⚠ WARNING**

#### **Rotating Components!**

Failure to disconnect power before servicing could result in rotating components cutting and slashing technician which could result in death or serious injury.

During installation, testing, servicing and troubleshooting of this product it may be necessary to work with live and exposed rotating components. Have a qualified or licensed service individual who has been properly trained in handling exposed rotating components, perform these tasks.

- Press the Auto key to start the test. Remember that the delay designated in step 8 must elapse before the system will begin to operate.
- Once each compressor or compressor pair has started, verify that the rotation is correct. If a scroll compressor is rotating backwards, it will not pump and a loud rattling sound can be observed. Check the electrical phasing at the load side of the compressor contactor. If the phasing is correct, before condemning the compressor, interchange any two leads to check the internal motor phasing. If the compressor runs backward for an extended period (15 to 30 minutes), the motor winding can over heat and cause the motor winding thermostats to open. This will cause a "compressor trip" diagnostic and stop the compressor.
- Press the STOP key and clear all Manual Overrides in

the unit control panel to stop the compressor operation.

- Repeat steps 5–11 for each compressor stage and the appropriate condenser fans.

## Refrigerant Charging

- Attach a set of service gauges onto the suction and discharge gauge ports for each circuit. See Figure 104, p. 155 for the various compressor locations.
- Open the access door, located in the unit control panel, and press the Manual Overrides key to display the first service screen. Refer to the latest edition of the applications programming guide for VAV applications for the Manual Overrides screens and programming instructions.
- Use tables in "Voltage Imbalance," p. 93 to program the following system components for the number 1 refrigeration circuit by scrolling through the displays;
  - VFD (100%, if applicable)
  - OCC/UNOCC Relay (Unoccupied for VAV units)
  - All Compressors for each circuit (On)
  - Condenser Fans for each circuit (On)

### **⚠ WARNING**

#### **Rotating Components!**

Failure to disconnect power before servicing could result in rotating components cutting and slashing technician which could result in death or serious injury.

Disconnect all electric power, including remote disconnects before servicing. Follow proper lockout/tagout procedures to ensure the power can not be inadvertently energized.

- Press the Auto Button key to start the test. Remember that the delay designated in step 4 must elapse before the system will begin to operate.
- After all of the compressors and condenser fans for the number 1 circuit have been operating for approximately 30 minutes, observe the operating pressures. Use the appropriate pressure curve found in "(60 Hz) Air-Cooled Condensers," p. 110 or "(50 Hz) Air-Cooled Condensers," p. 124 to determine the proper operating pressures. For superheat and subcooling guidelines, refer to "Expansion Valves," p. 158.

**Important:** Do Not release refrigerant to the atmosphere! If adding or removing refrigerant is required, the service technician must comply with all Federal, State and local laws.

- Verify that the oil level in each compressor is correct. The oil level may be down to the bottom of the sightglass but should never be above the sightglass.
- Press the STOP key and clear all Manual Overrides in the unit control panel to stop the system operation.

8. Repeat steps 1 through 8 for the number 2 refrigeration circuit.
9. After shutting the system off, check the compressor oil appearance. Discoloration of the oil indicates that an abnormal condition has occurred. If the oil is dark and smells burnt, it has overheated because: the compressor is operating at extremely high condensing temperatures; high superheat; a compressor mechanical failure; or, occurrence of a motor burnout.

If the oil is black and contains metal flakes, a mechanical failure has occurred. This symptom is often accompanied by a high compressor amperage draw.

If a motor burnout is suspected, use an acid test kit to check the condition of the oil. Test results will indicate an acid level exceeding 0.05 mg KOH/g if a burnout occurred.

The scroll compressor uses Trane OIL00079 (one quart container) or OIL00080 (one gallon container) without substitution. The appropriate oil charge for CSHN184/CSHL169, CSHN250/CSHL227 and CSHL285 scroll compressors is 14.2 pints. For CSHL346 scroll compressor, use 15.2 pints.

## Compressor Crankcase Heaters

Each scroll compressor is equipped with a 160-watt crankcase heater.

**Table 55. Crankcase heater sizes**

Compressor Name	Crankcase Heater Watts
ZPS*	70
ZP*	90
CSHD*	
VZH088*, VZH117*	
VZH170*	160
CSHN/CSHL*	

## Compressor Operational Sounds

Because of the scroll compressor design, it emits a higher frequency tone (sound) than a reciprocating compressor. It is designed to accommodate liquids, both oil and refrigerant, without causing compressor damage. The following sections describe some of the operational sounds that differentiate it from those typically associated with a reciprocating compressor. These sounds do not affect the operation or reliability of the compressor.

### At Shutdown

When a Scroll compressor shuts down, the gas within the scroll expands and causes momentary reverse rotation until the discharge check valve closes. This results in a "flutter" type sound.

## At Low Ambient Start-Up

When the compressor starts up under low ambient conditions, the initial flow rate of the compressor is low due to the low condensing pressure. This causes a low differential across the expansion valve that limits its capacity. Under these conditions, it is not unusual to hear the compressor rattle until the suction pressure climbs and the flow rate increases.

## Variable Speed Compressors

At all operating speeds, eFlex™ permanent magnet variable speed compressors sound different than fixed speed scrolls. At low speed, variable speed compressors can sputter. At high speed, variable speed compressor buzz. These are normal operating sounds. To ensure a quiet installation, eFlex variable speed compressors are installed in a sound enclosure. Make sure and keep the sound enclosure installed at all times other than servicing.

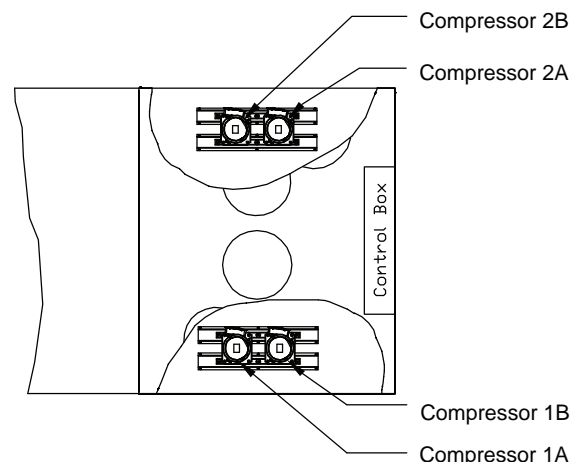
**Important:** Variable speed scroll compressors sound different than single speed scroll compressors. Sound changes with speed and condition.

## Electronic Compressor Protection Module (CPM)

The CSHN/CHSL\*\*\* compressors come equipped with a compressor protection device (CPM) capable of detecting phase reversal, phase loss, and motor overheating. When a fault is identified, the output relay will open. Depending on the fault, the CPM may either auto-reset or it may lock-out. The CPM can be manually reset by cycling control power.

**Note:** If the compressor has tripped due to an overheated windings condition, the motor winding temperature sensor resistance (PTC) will be 4500 ohms or greater; the resistance must be less than 2750 ohms before the 5 minute reset timer becomes enabled.

**Figure 104. Compressor locations and staging sequence (fixed speed compressors)**



**Table 56. Staging sequence 90 ton standard and hi capacity**

Stage	Comp 1A	Comp 1B	Comp 2A	Comp 2B
1	X			
2	X		X	
3	X	X	X	
4	X	X	X	X

**Table 57. Staging sequence 105, 130, 150 ton standard and hi capacity**

Stage	Comp 1A	Comp 1B	Comp 1C	Comp 2A	Comp 2B	Comp 2C
1	X					
2	X			X		
3	X	X		X		
4	X	X		X	X	
5	X	X	X	X	X	
6	X	X	X	X	X	X

**Table 58. Staging sequence 120 ton standard and hi capacity**

Stage	Comp 1A	Comp 1B	Comp 1C	Comp 2A	Comp 2B	Comp 2C
1		X				
2		X				X
3	X	X				X
4	X	X			X	X
5	X	X		X	X	X
6	X	X	X	X	X	X

**Table 59. Compressor data (fixed speed compressors)**

Unit Size	Compressors					
	Comp 1A	Comp 1B	Comp 1C	Comp 2A	Comp 2B	Comp 2C
90 Ton Std & Hi Capacity	CSHN 250	CSHN 250		CSHN 250	CSHN 250	
105 Ton Std & Hi Capacity	CSHN 184	CSHN 184	CSHN 184	CSHN 184	CSHN 184	CSHN 184

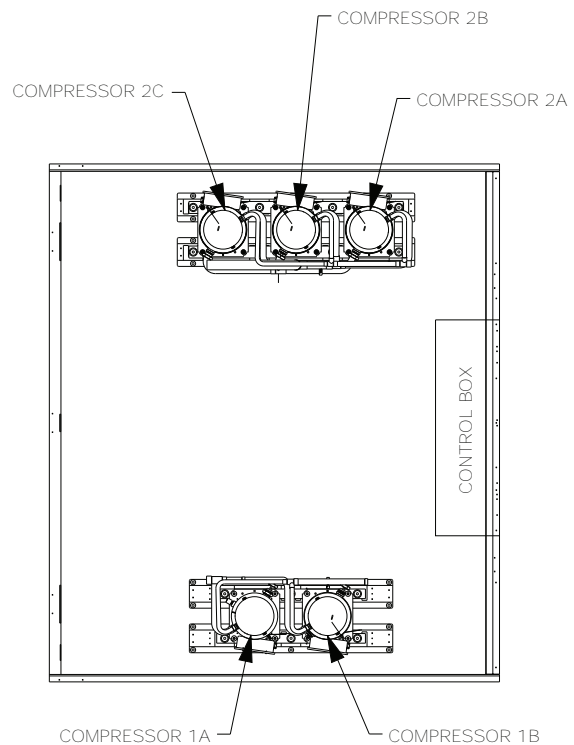
**Table 60. eFlex™ staging sequence and compressor data**

90 Ton eFlex™ Variable Speed Compressor Standard Capacity Evaporator							
Stage	1A: VZH 170	1B: CSHL 169	2A: CSHL 169	2B: CSHL 169	2C: CSHL 169	VZH Min Speed	VZH Max Speed

**Table 59. Compressor data (fixed speed compressors) (continued)**

Unit Size	Compressors					
	Comp 1A	Comp 1B	Comp 1C	Comp 2A	Comp 2B	Comp 2C
120 Ton Std & Hi Capacity	CSHN 184	CSHN 184	CSHN 250	CSHN 184	CSHN 184	CSHN 250
130 Ton Std & Hi Capacity	CSHN 240	CSHN 240	CSHN 240	CSHN 240	CSHN 240	CSHN 240
150 Ton Std Capacity	CSHN 250	CSHN 250	CSHN 250	CSHN 250	CSHN 250	CSHN 250

**Figure 105. eFlex™ compressor locations and staging sequence**



**Table 60. eFlex™ staging sequence and compressor data (continued)**

1	X					2520	5460
2	X		X			1500	6000
3	X		X	X		2520	5280
4	X	X	X	X		1500	6000
5	X	X	X	X	X	2520	4740
<b>90 Ton eFlex™ Variable Speed Compressor High Capacity Evaporator</b>							
Stage	1A: VZH 170	1B: CSHL 169	2A: CSHL 169	2B: CSHL 169	2C: CSHL 169	VZH Min Speed	VZH Max Speed
1	X					2580	5400
2	X		X			1500	6000
3	X		X	X		2580	5280
4	X	X	X	X		1500	6000
5	X	X	X	X	X	2460	4500
<b>105 Ton eFlex™ Variable Speed Compressor Standard Capacity Evaporator</b>							
Stage	1A: VZH 170	1B: CSHL 227	2A: CSHL 169	2B: CSHL 169	2C: CSHL 169	VZH Min Speed	VZH Max Speed
1	X					2820	5460
2	X		X			1500	6000
3	X		X	X		2400	6000
4	X	X	X	X		1500	5460
5	X	X	X	X	X	1680	5280
<b>105 Ton eFlex™ Variable Speed Compressor High Capacity Evaporator</b>							
Stage	1A: VZH 170	1B: CSHL 227	2A: CSHL 169	2B: CSHL 169	2C: CSHL 169	VZH Min Speed	VZH Max Speed
1	X					2880	5400
2	X		X			1500	6000
3	X		X	X		2520	6000
4	X	X	X	X		1500	5460
5	X	X	X	X	X	1680	5280
<b>120 Ton eFlex™ Variable Speed Compressor Standard Capacity Evaporator</b>							
Stage	1A: VZH 170	1B: CSHL 285	2A: CSHL 169	2B: CSHL 169	2C: CSHL 227	VZH Min Speed	VZH Max Speed
1	X					3060	5700
2	X			X		1740	6000
3	X		X	X		2400	6000
4	X	X	X	X		1500	6000
5	X	X	X	X	X	1500	4500
<b>120 Ton eFlex™ Variable Speed Compressor High Capacity Evaporator</b>							
Stage	1A: VZH 170	1B: CSHL 285	2A: CSHL 169	2B: CSHL 169	2C: CSHL 227	VZH Min Speed	VZH Max Speed
1	X					3240	5760
2	X			X		1800	6000
3	X		X	X		2400	6000
4	X	X	X	X		1500	6000
5	X	X	X	X	X	1500	5280



## Unit Startup

**Table 60. eFlex™ staging sequence and compressor data (continued)**

130 Ton eFlex™ Variable Speed Compressor Standard Capacity Evaporator							
Stage	1A: VZH 170	1B: CSHL 346	2A: CSHL 227	2B: CSHL 227	2C: CSHL 227	VZH Min Speed	VZH Max Speed
1	X					3600	6000
2	X		X			1500	6000
3	X		X	X		2160	4560
4	X	X	X			1500	6000
5	X	X	X	X		1500	6000
6	X	X	X	X	X	1500	4620
130 Ton eFlex™ Variable Speed Compressor High Capacity Evaporator							
Stage	1A: VZH 170	1B: CSHL 346	2A: CSHL 227	2B: CSHL 227	2C: CSHL 227	VZH Min Speed	VZH Max Speed
1	X					3780	6000
2	X		X			2640	6000
3	X		X	X		2160	4560
4	X	X	X			1500	6000
5	X	X	X	X		1500	6000
6	X	X	X	X	X	1500	4740
150 Ton eFlex™ Variable Speed Compressor Standard Capacity Evaporator							
Stage	1A: VZH 170	1B: CSHL 346	2A: CSHL 227	2B: CSHL 169	2C: CSHL 346	VZH Min Speed	VZH Max Speed
1	X					4080	6000
2	X			X		2700	5340
3	X		X			3720	6000
4	X		X	X		2820	5640
5	X	X	X			1500	5040
6	X	X			X	1500	5580
7	X	X		X	X	1500	6000
8	X	X	X	X	X	1500	6000

## Expansion Valves

All Intellipak 2 with Symbio systems use electronic expansion valves (EXVs) to control superheat. These valves are factory set to 12°F of superheat to balance efficiency and compressor reliability at all operating conditions. This setting can be adjusted through the Symbio controller display, but this is only recommended to be done at the discretion of Trane Product Support.

Pressure curves included in this document are based on outdoor ambient between 65° & 105°F, relative humidity above 40 percent. Measuring the operating pressures can be meaningless outside of these ranges.

## Measuring Superheat

1. Measure the suction pressure at the suction line gauge access port located near the compressor, or use the Suction Pressure reading from the Symbio controller.
2. Using a Refrigerant/Temperature chart, convert the

pressure reading to a corresponding saturated vapor temperature.

3. Measure the suction line temperature as close to the suction line temp sensor as possible, or use the Suction Temperature reading in Symbio. Use a thermocouple type probe for an accurate reading.
4. Subtract the saturated vapor temperature obtained in step 2 from the actual suction line temperature obtained in step 3. The difference between the two temperatures is known as "superheat".

When adjusting superheat, recheck the system subcooling before shutting the system "Off".

**Note:** If unit includes the modulating reheat dehumidification option, adjust superheat only in the cooling mode of operation.

## Charging by Subcooling

The outdoor ambient temperature must be between 65 and 105°F and the relative humidity of the air entering the evaporator must be above 40 percent. When the temperatures are outside of these ranges, measuring the operating pressures can be meaningless. Make sure hot gas bypass (if applicable) is not flowing when taking performance measurements. With the unit operating at "Full Circuit Capacity", acceptable subcooling ranges for air-cooled units is between 10°F to 23°F.

### Measuring Subcooling

1. At the liquid line service port, measure the liquid line pressure. Using an R-410A pressure/temperature chart, convert the pressure reading into the corresponding saturated temperature.
2. Measure the actual liquid line temperature as close to the liquid line service port as possible. To ensure an accurate reading, clean the line thoroughly where the temperature sensor will be attached. After securing the sensor to the line, insulate the sensor and line to isolate it from the ambient air. Use a thermocouple type probe for an accurate reading.

**Note:** Glass thermometers do not have sufficient contact area to give an accurate reading.

3. Determine the system subcooling by subtracting the actual liquid line temperature (measured in step 2) from the saturated liquid temperature (converted in step 1).

### Standard Ambient Units

The following Table gives the minimum starting temperatures for Standard Ambient Units. Do not start the unit in the cooling mode if the ambient temperature is below the recommended operating temperatures.

**Table 61. Minimum ambient**

Minimum Starting Ambient	
Unit Size	Standard Ambient
90-150	45

**Note:** Minimum starting ambients in degrees F and is based on unit operating at min. step of unloading, and unloading and 5 mph wind across condenser

## Electric, Steam and Hot Water Start-Up

1. Ensure that the "System" selection switch at the remote panel is in the Off position.
2. Close the disconnect switch or circuit protector switch that provides the supply power to the unit terminal block or the unit-mounted disconnect switch.

### ⚠ WARNING

#### Hazardous Voltage!

Failure to disconnect power before servicing could result in death or serious injury.

Disconnect all electric power, including remote disconnects before servicing. Follow proper lockout/tagout procedures to ensure the power can not be inadvertently energized. Verify that no power is present with a voltmeter.

**Important:** Do not open the service access doors while the unit is operating. HIGH VOLTAGE IS PRESENT AT TERMINAL BLOCK OR UNIT DISCONNECT SWITCH.

3. Turn the 115 volt control circuit switch and the 24 volt control circuit switch to the On position.
4. Open the User Interface access door, located in the unit control panel, and press the Manual Overrides key to display the first service screen. Refer to the latest edition of the appropriate programming manual for VAV applications for the Manual Overrides screens and programming instructions.
5. Use tables in "Voltage Imbalance," p. 93 to program the following system components for operation by scrolling through the User Interface displays:

#### Electric Heat

Supply Fan (On)  
Variable Frequency Drive (100% Output, if applicable)  
RTM Occ/Unocc Output (Unoccupied)  
Heat Stages 1 & 2 (On)

#### Steam or Hot Water Heat

Supply Fan (On)  
Variable Frequency Drive (100% Output, if applicable)  
RTM Occ/Unocc Output (Unoccupied)  
Hydronic Heat Actuator (100% Open)

Open the main steam or hot water valve supplying the rooftop heater coils.

6. Once the configuration for the appropriate heating system is complete, press the Auto key.

### ⚠ WARNING

#### Rotating Components!

Failure to disconnect power before servicing could result in rotating components cutting and slashing technician which could result in death or serious injury.

During installation, testing, servicing and troubleshooting of this product it may be necessary to work with live and exposed rotating components. Have a qualified or licensed service individual who has been properly trained in handling exposed rotating components, perform these tasks.

7. Press the TEST START key to start the test.



## Unit Startup

Remember that the delay designated in step 6 must elapse before the fan will begin to operate.

- Once the system has started, verify that the electric heat or the hydronic heat system is operating properly by using appropriate service technics; i.e. amperage readings, delta tees, etc.
- Press the STOP key at the User Interface Module in the unit control panel to stop the system operation.

## Gas Furnace Start-Up

It is important to establish and maintain the appropriate air/fuel mixture to assure that the gas furnace operates safely and efficiently.

Since the proper manifold gas pressure for a particular installation will vary due to the specific BTU content of the local gas supply, adjust the burner based on carbon dioxide and oxygen levels.

The volume of air supplied by the combustion blower determines the amount of oxygen available for combustion, while the manifold gas pressure establishes fuel input. By measuring the percentage of carbon dioxide produced as a by-product of combustion, the operator can estimate the amount of oxygen used and modify the air volume or the gas pressure to obtain the proper air/fuel ratio.

Confirming the correct air/fuel mixture for a furnace results in rated burner output, limited production of carbon monoxide, and a steady flame that minimizes nuisance shutdowns.

### **⚠ WARNING**

#### **Hazardous Gases and Flammable Vapors!**

**Failure to observe the following instructions could result in exposure to hazardous gases, fuel substances, or substances from incomplete combustion, which could result in death or serious injury. The state of California has determined that these substances may cause cancer, birth defects, or other reproductive harm.**

**Improper installation, adjustment, alteration, service or use of this product could cause flammable mixtures or lead to excessive carbon monoxide. To avoid hazardous gases and flammable vapors follow proper installation and setup of this product and all warnings as provided in this manual.**

### **⚠ WARNING**

#### **Explosion Hazard!**

**Failure to properly regulate pressure could result in a violent explosion, which could result in death, serious injury, or equipment or property-only-damage.**

**When using dry nitrogen cylinders for pressurizing units for leak testing, always provide a pressure regulator on the cylinder to prevent excessively high unit pressures. Never pressurize unit above the maximum recommended unit test pressure as specified in applicable unit literature.**

### **⚠ WARNING**

#### **Rotating Components!**

**Failure to disconnect power before servicing could result in rotating components cutting and slashing technician which could result in death or serious injury.**

**During installation, testing, servicing and troubleshooting of this product it may be necessary to work with live and exposed rotating components. Have a qualified or licensed service individual who has been properly trained in handling exposed rotating components, perform these tasks.**

## 2-stage and Modulating Gas Furnace

2-stage and modulating gas heaters are available for all heater sizes - 850, 1100, 1800, and 2500 MBh.

### Unit Control

The unit is controlled by a supply air temperature sensor located in the supply air stream for Discharge Temperature Control units. Zone Temperature Control units have two sensors, one located in the supply air stream and the zone sensor. The temperature sensor signal is sent to the Symbio controller of the IntelliPak unit. The control signal from the Symbio controller is 2-10V DC for modulating gas heat.

The greater DC voltage, the greater the call for gas and the higher the firing rate of the heater. As the temperature setpoint is reached, the modulating heat controller will cause the combustion air speed to change to a lower firing rate that matches the heat load of the space. For 2-stage heat, the control signal will have a mid range voltage (4 - 5V DC) for stage one and 10V DC for stage two.



## 2-stage and Modulating Burner Setup

**Important:** It is necessary to measure gas pressure at the following points listed below. Install the necessary fittings prior to starting the burner in the Manual Override.

- Inlet Pressure (see [Figure 109, p. 163](#))
- Main Gas Regulator outlet pressure (see [Figure 109, p. 163](#))
- Load Line Pressure (see [Figure 108, p. 162](#))
- Manifold Pressure (see [Figure 110, p. 163](#))

**Important:** Flue readings should be taken from center of the flue and at least 4 inches down from the outlet. See [Figure 112, p. 164](#).

1. Program the following system components for operation by scrolling through the user interface displays:
  - a. Open the manual gas valve, located in the gas heat section.
  - b. Set toggle switch located on heater control box to ON.
  - c. Press Stop button on user interface.
  - d. Navigate to the Gas Heat Manual override screen. See [Figure 106, p. 162](#) for 2-stage and [Figure 107, p. 162](#) for modulating. Set the modulating percentage to 1% and/or enable the 1<sup>st</sup> stage. Touch the Auto button in the top right corner of the screen.
  - e. Turn the Supply Fan ON by the navigating to the Manual Override Screen. Set the Fan speed to 100%.

### Low Fire Adjustment

2. After the initial purge sequence and once the burner has started, run the burner at low fire for 10 minutes to allow the burner to stabilize.
3. Use a flue analyzer to measure the oxygen (O<sub>2</sub>), carbon dioxide (CO<sub>2</sub>), and carbon monoxide (CO) levels in the flue gas. Take several readings to ensure burner operation is stable.

If the measured O<sub>2</sub> level is between 17.0%-19.0% and the CO<sub>2</sub> level is no more than 400ppm (corrected to 3% O<sub>2</sub>), no adjustment is necessary. If an adjustment is needed, turn the adjustment screw on the ratio regulator. CCW to increase O<sub>2</sub>, CW to decrease O<sub>2</sub>. See [Figure 108, p. 162](#).

**Note:** Ratio regulator turns affects amount of gas flow. The number of turns on the ratio regulator is preset at the factory. Only small adjustments should be made for fine tuning combustion.

### High Fire Adjustment

4. Adjust the user interface to operate the furnace at max firing rate (100%) or 2<sup>nd</sup> Stage. Allow the system to operate for 10 minutes to stabilize the burner.
 

**Note:** The burner capacity is controlled by the combustion fan speed. This has been preset at the factory and normally does not need field adjustment.
  5. Check the inlet pressure at the tap upstream of the pilot regulator. Refer to the illustration in [Figure 109, p. 163](#). The inlet pressure should be between 7.0" to 14.0" w.c.
  6. Check the outlet pressure of the main gas regulator at tap on the upstream solenoid valve. Refer to the illustration in [Figure 109, p. 163](#). The outlet pressure from the main gas regulator should be 6.0" w.c.
  7. Check manifold pressure at tap closest to where the valve train attaches to the burner. Refer to the illustration in [Figure 110, p. 163](#). Verify the manifold pressure is within range shown in Chart B ([Table 63, p. 162](#)). If manifold pressure is not within the specified range, contact Large Commercial Technical Support for information on how to adjust maximum fan speed (FHi).
  8. Use a flue analyzer to measure the oxygen (O<sub>2</sub>), carbon dioxide (CO<sub>2</sub>), and carbon monoxide (CO) levels in the flue gas. If the measured oxygen level is between 3.0 to 5.0% and the carbon dioxide level is between 8.5 to 10% and the CO is less than 100 PPM, no adjustment is necessary. If an adjustment is needed, check the inlet gas pressure or the air damper on the burner (closing will increase the CO<sub>2</sub> level). See [Figure 111, p. 163](#).
 

For 2-stage, proceed to [Step 12](#). For modulating, continue to [Step 9](#).
- ### Mid Fire Adjustment (for modulating burners only)
9. Adjust the user interface to operate the furnace at mid firing rate (approx. 38%).
  10. Check the load line pressure on the ratio regulator. Using the Modulating Gas Heat Actuator screen adjust the % value until load line pressure is at 2" w.c.
  11. Check manifold pressure at tap closest to where valve train attaches to the burner. Refer to the illustration in [Figure 110, p. 163](#). Verify the manifold pressure is 0.8 - 0.9" w.c. If adjustment is necessary, turn the adjustment screw on the ratio regulator. Refer to illustration in for the adjustment screw location.
  12. Program the burner for low fire operation (1%) or 1st stage and recheck O<sub>2</sub> (or CO<sub>2</sub>) and CO values.
  13. Press the STOP key on the user interface screen and remove manual overrides to stop the system operation.

**Table 62. Chart A - Manual override mode setup parameters**

Modulating Gas Heat Actuator (Service Mode)	Low Fire (1%)	Mid Fire (38%) (see note)	High Fire (100%)
VDC Signal to actuator	See Table 64, p. 163	5.0 VDC	10.0 VDC
Inlet Pressure	7.0" to 14.0"	7.0" to 14.0"	7.0" to 14.0"
Main Gas Regulator Pressure - NG	6.0"	6.0"	6.0"
Load Line Pressure - NG		2.0"	
Manifold Pressure - NG		0.8" to 0.9"	See chart B
Main Gas Regulator Pressure - LP	10.0"	10.0"	10.0"
Load Line Pressure - LP		0.9"	
Manifold Pressure - LP		0.12" to 0.17"	See chart B

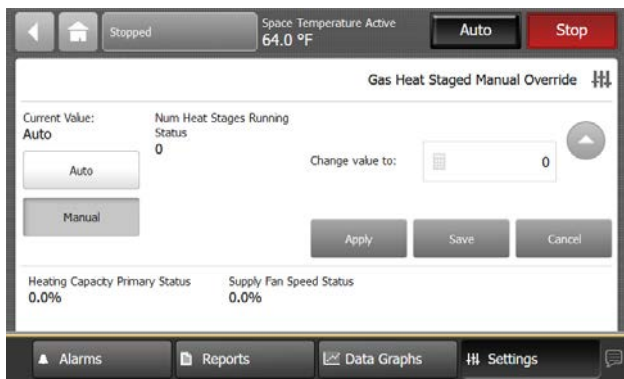
**Note:** In the manual override mode, adjust the % output until the Load Line Pressure is correct, then verify/ adjust manifold pressure.

**Table 63. Chart B - high fire manifold pressure**

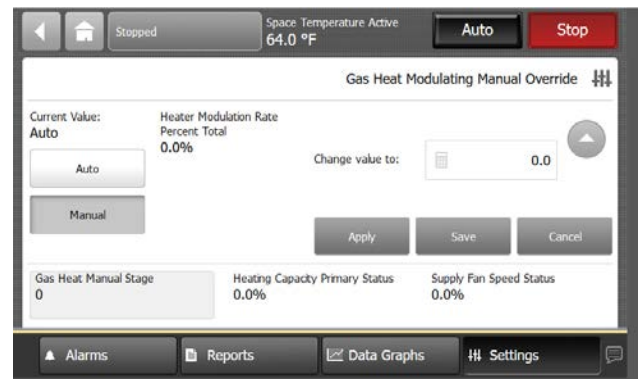
Burner size	High Fire Manifold Pressure	
	NG	LP
850 MBh	1.6" to 1.9"	0.68" to 0.72"
1100 MBh	2.4 to 2.8"	0.92" to 0.96"
1800 MBh	3.2 to 3.6"	n/a
2500 MBh	3.3 to 3.7"	n/a

**Note:** If the manifold pressure is not within the range shown on the chart, then the maximum combustion fan speed (Fhi) needs adjustment. Contact Large Commercial Technical Support for assistance.

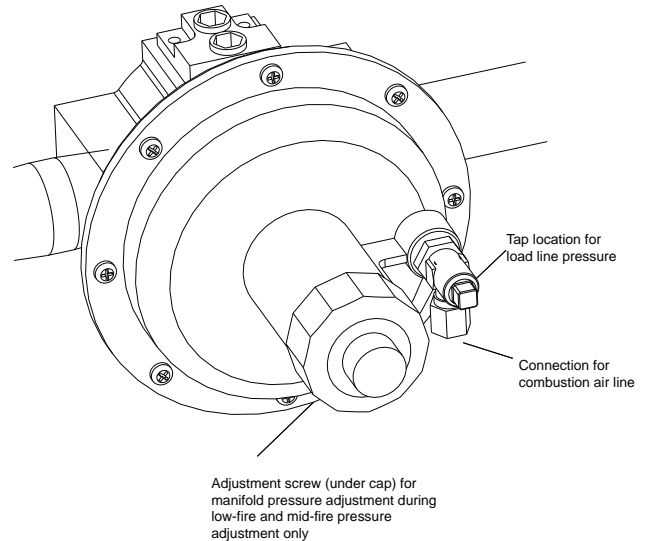
**Figure 106. Gas Heat Manual Override screen — 2-stage**



**Figure 107. Gas Heat Manual Override screen - modulating**

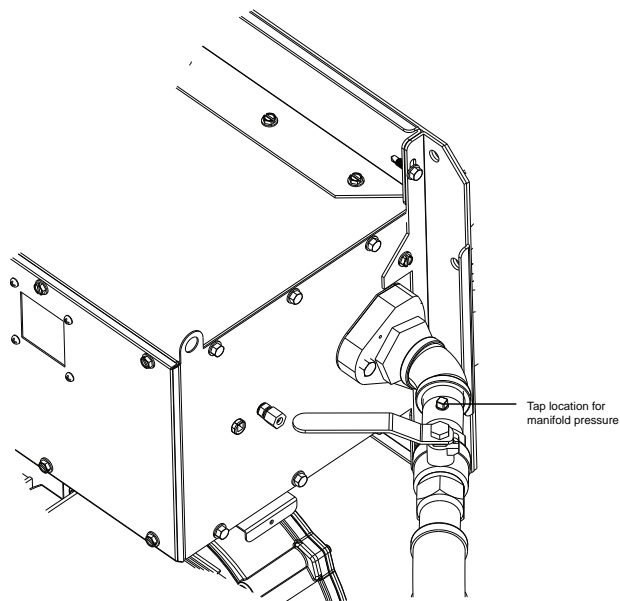


**Figure 108. Ratio regulator**

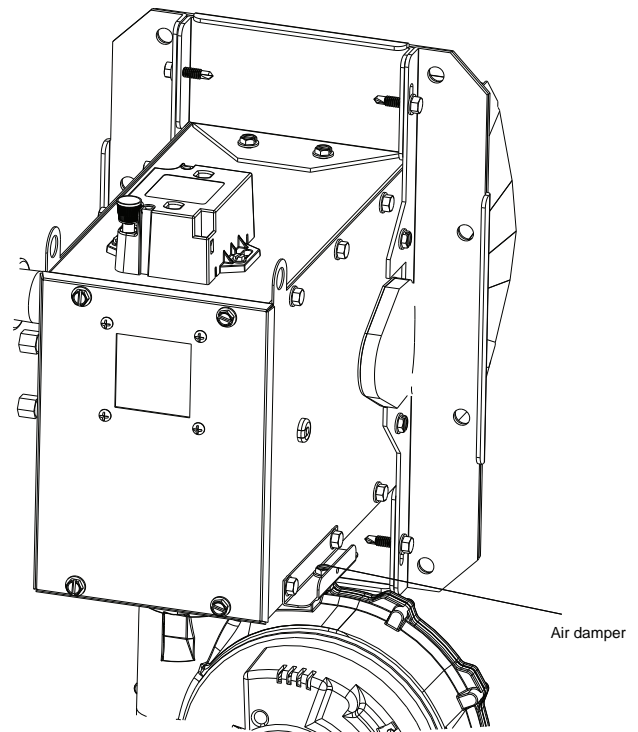


**Figure 109. Main gas regulator and inlet pressure tap locations**

**Figure 110. Manifold pressure tap location**



**Figure 111. Air damper location**



**Table 64. 2-stage and modulating gas heat settings**

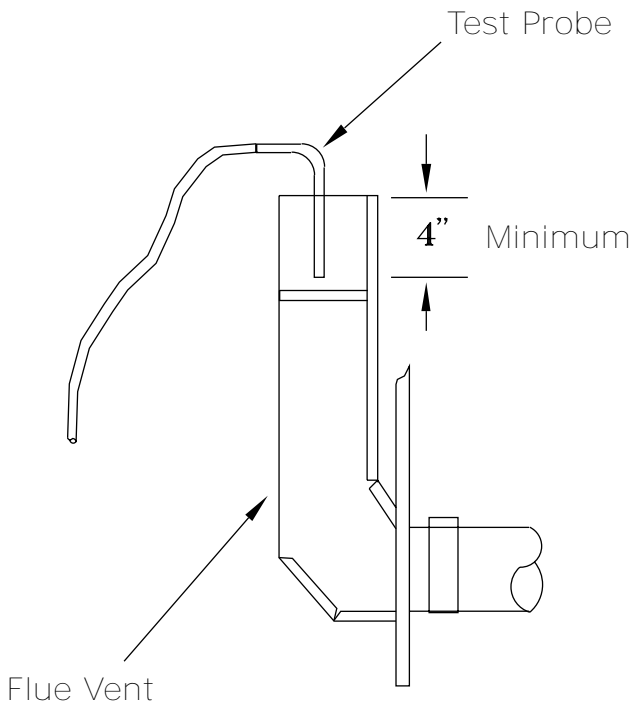
Burner Size	Low Fire VDC Signal	Natural Gas <sup>(a)</sup>			Propane		
		Ratio Regulator Turns <sup>(b)</sup>	FHi Fan Speed <sup>(c)</sup>		FHi Fan Speed <sup>(c)</sup>		Orifice
			EBM	Fasco	EBM	Fasco	
850 MBH 2-stg	4.75	10-12 CCW	50%	49%	46%	TBD	0.516
850 MBH Mod	2	10-12 CCW	50%	49%	46%	TBD	0.516
1100 MBH 2-stg	4.5	10-12 CCW	80%	TBD	61%	TBD	0.516
1100 MBH Mod	2	10-12 CCW	80%	TBD	61%	TBD	0.516
1800 MBH 2-stg	4.5	10-12 CCW	100%	70%	na	na	na
1800 MBH Mod	2	10-12 CCW	100%	70%	na	na	na
2500 MBH 2-stg	5	10-12 CCW	100%	77%	na	na	na
2500 MBH Mod	2	10-12 CCW	100%	77%	na	na	na

<sup>(a)</sup> Burner is preset to the default Natural Gas settings from the factory.

<sup>(b)</sup> Number of turns for Ratio Regulator is counted from starting position of all the way in.

<sup>(c)</sup> FHi and FLo Fan speed is adjustable by calling Technical Support. FLo is 10% for EBM and 15% for Fasco.

**Figure 112. Flue gas carbon dioxide and oxygen measurements**



## Final Unit Checkout

After completing all of the checkout and start-up procedures outlined in the previous sections (i.e., operating the unit in each of its Modes through all available stages of cooling and heating), perform these final checks before leaving the unit:

### **⚠ WARNING**

#### **Hazardous Voltage!**

**Failure to disconnect power before servicing could result in death or serious injury.**

**Disconnect all electric power, including remote disconnects before servicing. Follow proper lockout/tagout procedures to ensure the power can not be inadvertently energized. Verify that no power is present with a voltmeter.**

**Important:** HIGH VOLTAGE IS PRESENT AT TERMINAL BLOCK OR UNIT DISCONNECT SWITCH.

- Close the disconnect switch or circuit protector switch that provides the supply power to the unit terminal block or the unit mounted disconnect switch.
- Turn the 115 volt control circuit switch Off.
- Turn the 24 volt control circuit switch to the On position.
- Press the SETUP key. The LCD screen will display various preset "parameters of operation" based on the unit type, size, and the installed options. Compare the factory preset information to the specified application requirements. If adjustments are required, follow the

step-by-step instructions provided in the appropriate programming manual for VAV applications.

- Program the Night Setback (NSB) panel (if applicable) for proper unoccupied operation. Refer to the programming instructions for the specific panel.
- Verify that the Remote panel "System" selection switch, "Fan" selection switch, and "Zone Temperature" settings for constant volume systems are correct.
- Verify that the Remote panel "System" selection switch and the "Supply Air Temperature" settings for variable air volume systems are correct.
- Inspect the unit for misplaced tools, hardware, and debris.
- Turn the 115 volt control circuit switch On.
- Press the AUTO key to begin system operation. The system will start automatically once the dampers modulate and a request for either heating or cooling has been given.
- Verify that all exterior panels including the control panel doors and condenser grilles are secured in place.

## Multi-piece Unit – Trane Start-Up

When the following are complete, Trane will provide unit start-up:

- IntelliPak 2 multi-piece unit has been installed.
- All shipped with items have been installed.
- All utilities and drain pipes have been connected.
- All refrigeration piping has been reconnected and refrigerant charge has been adequately distributed throughout the system.
- All ductwork has been attached to the unit.

Trane start-up of multi-piece units will review the overall unit for exterior damage (dents, bends, missing panels, doors work properly), verify that the unit interior is free from debris/obstructions, ensure that the panels and doors are secured properly and verify that all wiring connections are tight. The overall installation will be reviewed to ensure the unit clearances are adequate to avoid air recirculation and all unit drain lines and traps are properly installed.

The unit main power will be reviewed to ensure the unit is properly grounded, the main power feed wire gauge is adequately sized, the correct voltage is supplied to unit and electric heaters, and the incoming voltage is phase balanced. Verification will be performed to ensure that all field installed control wiring is applied to the correct terminals, all automation and remote controls installed/wired and control wiring for SZVAV and VAV controls is completed.

The refrigeration system will be reviewed to ensure the coil fins are straightened, the removal of shipping hardware and plastic covers for compressors, proper oil level in the compressors, crankcase heaters have been operational for at least 12 hours time prior to Trane start-up being performed. The proper compressor voltage and amperage, correct position of service valves prior to start-up and

proper system subcooling and superheat will be verified. The unit fans will be checked to ensure that the condenser fan blade set-screws to the motor shaft are tight, that the hold down bolts and channels from fan sections have been removed, proper adjustment of fan section spring isolators, proper fan belts tension, adequate fan bearings grease, alignment of fan sheaves, adequate tightness of supply and exhaust fan pulley bolts, proper fan rotation, and proper fan motor amperage.

A check will be made to ensure both piping to the condenser and air handler side of the system have been completed and interconnecting refrigerant tubing has been evacuated by the contractor prior to Trane performing the start-up. All damper linkages will be checked for proper adjustment, and proper damper operation and outside air pressure sensors verified.

Units equipped with electric heaters will be checked to ensure that the heating system matches the unit nameplate and for correct voltage supply to the heaters. Units equipped with gas heaters will be checked to ensure that the flue assembly is secure and properly installed, sufficient gas pressure exists according to pipe size, no

leaks exist in gas supply line, the gas heat piping includes a drip leg, condensate line and the combustion air CO<sub>2</sub> and O<sub>2</sub> levels are normal. Units equipped with hot water heat will be checked to ensure that the hot water pipes are properly routed, sized and leak free; for the presence of swing joints or flexible connectors next to the hot water coil; proper gate valve installation in the supply and return branch line; proper three way modulating valve installation, and proper coil venting will be verified.

Units equipped with steam heat will be checked to ensure that the hot water pipes are properly routed, sized and leak free; proper swing check vacuum breaker installation; proper 2-way modulating valve installation; proper steam trap installation. Units equipped with energy recovery wheels will be checked to ensure proper rotation and operation of the wheel. The service test guide will be used to check proper component operation. Finally, the program set points for proper unit operation will be validated through human interface module. Once the IntelliPak 2 multi-piece unit has been started, a communication will be provided of start-up activities and the associated operating log.



# Trane Startup Checklist

This checklist is intended to be a guide for the Trane technician just prior to unit 'startup'. Many of the recommended checks and actions could expose the technician to electrical and mechanical hazards. Refer to the appropriate sections in the this manual for appropriate procedures, component specifications and safety instructions.

**Important:** Except where noted, it is implied that the Trane technician is to use this checklist for inspection/verification of prior tasks completed by the general contractor at installation. Use the line item content to also record the associated values onto the Trane unitary packaged equipment log.

**Important:** This checklist is not intended as a substitution for the contractor's installation instruction.

<b>Job Name</b>		<b>Serial #</b>	
<b>Job Location</b>		<b>Model #</b>	
<b>Sales Order #</b>		<b>Ship Date</b>	
<b>Unit DL # (special units)</b>		<b>Date</b>	
<b>Starting Sales Office</b>		<b>Technician</b>	

**Table 65. Startup checklist for S\*HN, 90–150 units**

		Complete		
		Yes	No	
1	Crankcase heaters working for 8 hours prior to arrival of Trane technician performing startup			
2	Correct voltage supplied to unit and electric heaters			
3	Unit exterior inspected			
4	Disconnect all power, Unit interior free from debris/obstructions etc.			
5	Open all access doors to verify all open and close fully without any binding			
6	All wiring connections tight			
7	Unit properly grounded			
8	Copper power wiring meets sizing requirement			
9	All field control wiring for CV, SZVAV or VAV controls completed			
10	All automation and remote controls installed/wired			
11	Unit clearances adequate for service and to avoid air recirculation etc.			
12	For 120-150T units remove foam shipping blocks from evaporator suction headers to allow proper condensate drainage.			
13	All unit drain lines and traps proper			
14	All coil fins inspected and straightened			
15	Shipping hardware for compressors removed			
16	Hold down bolts and channels from fan sections removed			
17	Fan section spring isolators checked/adjusted			
18	Damper linkages tight/adjusted			
19	Rail connector splice brackets installed on low side base rail			
Where applicable: Electric Heat				
20	Electric heat circuits have continuity			
Where applicable: Gas Heat				
21	Gas heat piping includes drip leg previously installed by controlling contractor			
22	Gas heat flue assembly fully installed			
23	Gas heat condensate line + heat tape installed where applicable			
24	Verify heating system matches the nameplate			
25	Perform Gas Heat startup procedure in IOM			
Where applicable: HW/Steam Heat				
26	Modulating valve and actuator (HW and Steam) installed/wired			
27	Steam heat swing check vacuum breakers installed per IOM direction			
28	Steam heat condensate trap provided			
29	O/A pressure sensor installed and piped			
30	High side to low side piping to be completed prior to Trane technician arriving for startup			
31	Space sensor and pneumatic tubing installed properly			
32	Compressor discharge service valves, oil valves and liquid lines valves open/back seated (excludes Schrader valves)			

**Table 65. Startup checklist for S\*HN, 90–150 units (continued)**

		Complete			
33	Compressor oil levels (½ -¾ high in glass) proper				
34	Verify power wires are connected in the high voltage power box				
35	Verify field installed control wiring landed on correct terminals				
36	All fan belts tensioned and bearings greased				
37	Heat wheel rotates freely by hand				
38	Reenergize power. Phase sequence (A-B-C) proper for compressor rotation				
39	Incoming voltage balanced				
40	All panels/doors secured prior to startup				
Start unit					
41	Service test guide used to operate unit components				
42	Fan amperages within nameplate specs				
43	Verify system airflow				
44	Dampers open and close properly				
45	Adjust outside air damper travel				
46	Compressor operation normal and within amperage rating				
47	Electric, hot water and steam heating operation checked				
48	Gas heating startup sequence of operation per IOM has been followed				
49	Gas heat operation has been verified with combustion analyzer				
50	Incoming gas pressure does not drop below 7" water column when burner is on high fire				
51	Operating log completed				

## Critical Control Parameters and Dry Bulb Changeover Map

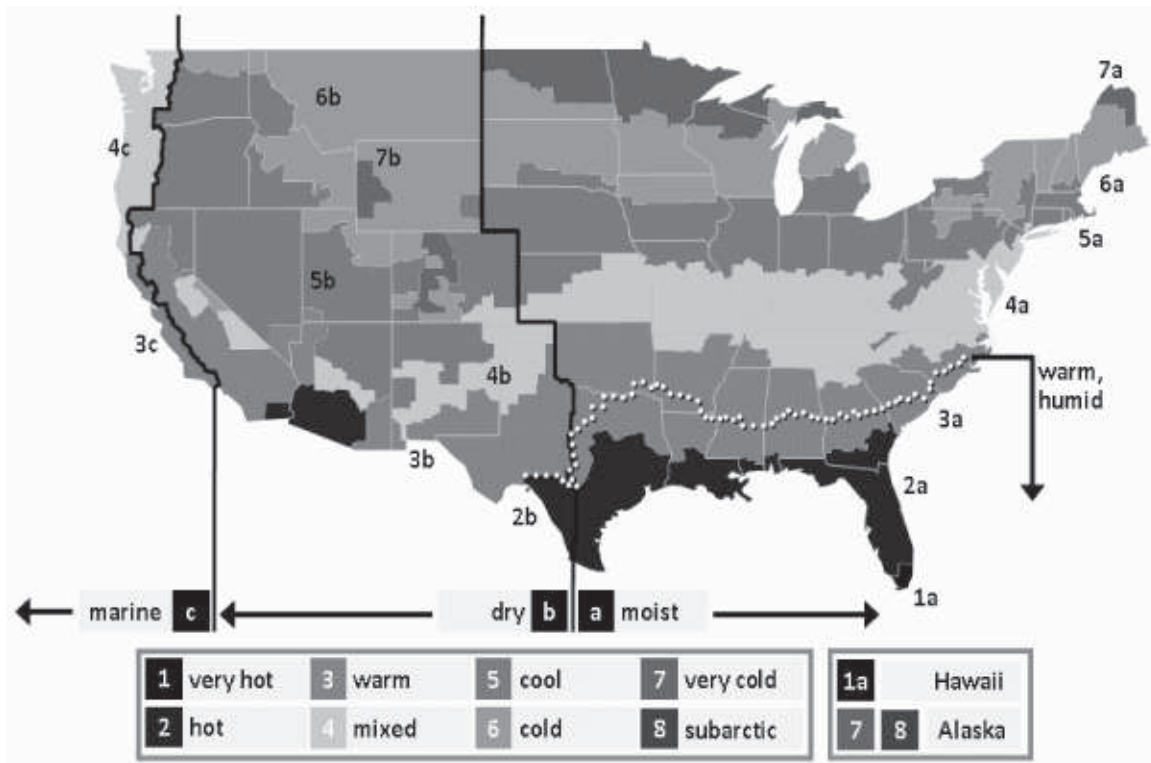
**Table 66. Critical control parameters**

Description	Suggested Parameter	Economizer Settings						
		Region 1	Region 2	Region 3	Region 4	Region 5	Region 6	Region 7
Supply Air Temperature Control Setpoint	55°F							
Supply Air Temperature Deadband	8°F							
Supply Air Pressure Setpoint	1.8" w.c.							
Supply Air Pressure Deadband	0.1" w.c.							
Building Static Pressure Setpoint	0.03" w.c.							
Building Static Pressure Deadband	0.04" w.c.							
Standby Freeze Avoidance	20%							
Relief Enable Setpoint	10%							
Economizer Minimum Position Setpoint	10%							
Fixed Dry Bulb Economizer C/O Type a (Moist)*		TOA > 65° F	TOA > 65° F	TOA > 65° F	TOA > 65° F	TOA > 70° F	TOA > 70° F	TOA > 70° F
Fixed Dry Bulb Economizer C/O Type b (Dry)*	TOA > 75°F							
Fixed Dry Bulb Economizer C/O Type c (Marine)*				TOA > 75° F	TOA > 75° F	TOA > 75° F		
Fixed Reference (Enthalpy Changeover)	HOA > 28 Btu							
Differential Comparative (Enthalpy Changeover)	HOA > HRA							

**Notes:**

- See map in next figure for dry bulb changeover.  
Examples:  
- Minneapolis, Minnesota is in "Region 6" and resides in "Moist" subregion, thus designation is 6b. Economizer changeover setting should be 75°F.  
- Charleston, South Carolina is in "Region 3" and resides in "Moist" subregion, thus the designation is 3c. Economizer changeover setting should be 65°F.
- Go to SETUP menu and input setting for parameters listed in the table above.
- Use the Dry bulb changeover map to determine region of country based on unit site location.
- Fixed speed compressor units 8°F deadband.
- eFlex™ compressor units 4°F deadband.

Figure 113. Dry bulb changeover map







# Service and Maintenance

## ⚠ WARNING

### Hazardous Voltage and Exposure to Ultraviolet Radiation!

This product contains components that emit high-intensity ultraviolet (UV-C) radiation which can be harmful to unprotected eyes and skin, and cause serious damage to the equipment.

Failure to disconnect power before servicing could result in burns or electrocution which could result in death or serious injury.

Disconnect all electrical power, including remote disconnects, and make sure the UV lights are off before servicing. Follow proper lockout/tagout procedures to ensure the power cannot be inadvertently energized.

Trane does not recommend field installation of ultraviolet lights in its equipment for the intended purpose of improving indoor air quality. Trane accepts no responsibility for the performance or operation of our equipment in which ultraviolet devices were installed outside of the Trane factory or its approved suppliers.

Table 67. Control settings and time delays

Control Description	Elec. Designation	Contacts Open	Contacts Closed
Combustion Airflow Switch (Gas Heat Only)	4S25	see note 1	0.1 - 0.25" wc rise in press diff
Supply Airflow Switch (Gas Heat Only)	4S38	0.03 - 0.12" wc	0.15 + 0.05" wc rise in press diff
Freezestat (Hydronic Heat Only)	4S12	(N.O.) Auto Reset	40°F
Pre-purge Timer: Honeywell (Gas Heat)	4U18	internal timing function	2 Stage 850/1100 MBH 60—seconds/All other configurations—30 seconds
Sequencing Time Delay Relay (Gas Heat)	4DL6	N.C. - timed to close	60 seconds + 20%

Note: The combustion airflow switch (4S25) differential is 0.02" - 0.08" wc.

Table 68. Gas heat—high limit

Tons	Fan Size (in)	Config.	Contacts	
			Open	Close
<b>2500 MBh High Limit</b>				
120-150	40	DF	220	180
	40	HZ	340	300
	32	DF & HORZ	240	220
<b>1800 MBh High Limit</b>				
120-150	32 & 40	DF	240	200
	32 & 40	HZ	220	180
90-105	32	DF & HZ	240	200
	36	DF & HZ	240	200
<b>1100 MBh High Limit</b>				
120-150	32	DF & HZ	240	200
	40	DF & HZ	240	200
90-105	32	DF & HZ	240	200
	36	DF & HZ	220	180
<b>850 MBh High Limit</b>				
90-105	32 & 36	DF & HZ	195	155



## Service and Maintenance

**Table 69. Electric heat—selection limits**

Tons	Indoor Fan Option	Electric Heat Option	Supply Discharge	Linear Limit - Open Temp.	Fan Fail Limit - Open Temp.	Manual Limit - Open Temp.
120-150	High (40")	High (300 kW)	Downflow	185°F	185°F	225°F
			Hz (right)	185°F	185°F	225°F
		Low (140 kW)	Downflow	150°F	185°F	225°F
			Hz (right)	150°F	185°F	225°F
	Low (32")	High (300 kW)	Downflow	205°F	185°F	225°F
			Hz (right)	185°F	185°F	225°F
		Low (140 kW)	Downflow	150°F	185°F	225°F
			Hz (right)	150°F	185°F	225°F
105	High (36")	High (262.5 kW)	Downflow	195°F	155°F	225°F
			Hz (right)	195°F	155°F	225°F
		Low (90 kW)	Downflow	150°F	175°F	225°F
			Hz (right)	150°F	175°F	225°F
	Low (32")	High (262.5 kW)	Downflow	225°F	185°F	225°F
			Hz (right)	205°F	185°F	225°F
		Low (90 kW)	Downflow	150°F	175°F	225°F
			Hz (right)	150°F	175°F	225°F
90	High (36")	High (262.5 kW)	Downflow	195°F	155°F	225°F
			Hz (right)	195°F	155°F	225°F
		Low (90 kW)	Downflow	150°F	175°F	225°F
			Hz (right)	150°F	175°F	225°F
	Low (25")	High (262.5 kW)	Downflow	215°F	155°F	215°F
			Hz (right)	235°F	155°F	215°F
		Low (90 kW)	Downflow	150°F	175°F	225°F
			Hz (right)	150°F	175°F	225°F

### Compressor Circuit Breakers

Every fixed speed compressor is protected by a circuit breaker. If replacement is necessary, please refer to the circuit breaker nameplate to identify the part number and manufacturer. Contact the circuit breaker manufacturer to locate the datasheet for the circuit breaker to find the "must hold / must trip" values.

### Supply and Relief/Return Fan Overloads

When the VFD bypass option is selected, each supply and relief/return fan is protected by a motor overload when in VFD bypass mode. On 60-75T units with dual DDP supply

fan motors (with or without VFD bypass option), each supply fan motor is protected by a motor overload in both standard operation and VFD bypass mode. The motor overloads are factory set to the motor FLA value and should not be adjusted. If the current to the motor exceeds the overload dial setting value, the overload relay auxiliary contacts will trip and interrupt the control signal to the run and bypass contactor coils. This will remove power from the fan motor and stop operation.

**Table 70. Unit internal fuse replacement data & VFD factory settings**

<b>Transformer Primary</b>			
Fuse-ID	Size	Type	
1F1	8A	Class CC Time Delay	
1F2			
1F27			
1F28			
<b>115VAC Circuits</b>			
Fuse-ID	Size	Type	
1S1	20A	Class CC Time Delay	
1S20			
1F3	10A		
1F4			
1F17	5A		
1F18			
<b>Power Meter</b>			
Fuse-ID	Size	Type	
1F19 (x3)	0.5A	Class CC Time Delay	
<b>Condenser Fan</b>			
Fuse-ID	Size	Type	
1F10 (x3)	30A	Class CC Time Delay	
1F11 (x3)			
1F31 (x3)			
1F32 (x3)			
1F33 (x3)			
1F34 (x3)			
<b>Energy Recovery Wheel</b>			
Fuse-ID	Size	Type	
1F35 (x3)	5A	Class CC Time Delay	
<b>Service Lights</b>			
Fuse-ID	Size	Type	
1S27 (x2)	2A	Class CC Time Delay	
1F38	3.2A	Cartridge Fuse Time Delay	
1F39			
<b>Convenience Outlet</b>			
Fuse-ID	Voltage	Size	Type
2S5 (x2)	460V	5A	Class CC Time Delay
	575V	4A	
<b>Compressor VFD</b>			



**Service and Maintenance**

**Table 70. Unit internal fuse replacement data & VFD factory settings (continued)**

Fuse-ID	Voltage	Size	Type								
1F14 (x3)	460	80A	Class J Fast Acting								
	575										
<b>Supply Fan VFD Non-Bypass</b>											
Fuse-ID	Voltage	15 HP	20 HP	25 HP	30 HP	40 HP	50 HP	60 HP	75 HP	100 HP	
1F5 (x3)	460	50A	50A	80A	80A	125A	125A	125A	200A	200A	
	575	30A	30A	80A	80A	80A	125A	125A	125A	na	
0-100A are Class J Fast Acting 110-200A are Class T Fast Acting											
<b>Supply Fan VFD with Bypass</b>											
Fuse-ID	Voltage	15 HP	20 HP	25 HP	30 HP	40 HP	50 HP	60 HP	75 HP	100 HP	
1F5 (x3)	460	35A	50A	60A	80A	100A	125A	150A	200A	200A	
	575	30A	40A	50A	60A	80A	100A	125A	150A	na	
Class J Time Delay											
<b>Supply Fan VFD with Bypass</b>											
Fuse-ID	Voltage	15 HP	20 HP	25 HP	30 HP	40 HP	50 HP	60 HP	75 HP	100 HP	
4F15 (x3)	460	50A	50A	80A	80A	125A	125A	125A	200A	200A	
	575	30A	30A	80A	80A	80A	125A	125A	125A	na	
0-100A are Class J Fast Acting 110-200A are Class T Fast Acting											
<b>Return / Relief Fan VFD Non-Bypass</b>											
Fuse-ID	Voltage	Motor Size									
		7.5 HP	10 HP	15 HP	20 HP	25 HP	30 HP	40 HP	50 HP	60 HP	
1F7 (x3)	460	25A	25A	50A	50A	80A	80A	125A	125A	125A	
	575	20A	20A	30A	30A	80A	80A	80A	125A	125A	
0-100A are Class J Fast Acting 110-200A are Class T Fast Acting											
<b>Return / Relief Fan VFD with Bypass</b>											
Fuse-ID	Voltage	Motor Size									
		7.5 HP	10 HP	15 HP	20 HP	25 HP	30 HP	40 HP	50 HP	60 HP	
1F7 (x3)	460	20A	25A	35A	50A	60A	80A	100A	125A	150A	
	575	15A	20A	30A	40A	50A	60A	80A	100A	125A	
Class J Time Delay											
<b>Return / Relief Fan VFD with Bypass</b>											
Fuse-ID	Voltage	Motor Size									
		7.5 HP	10 HP	15 HP	20 HP	25 HP	30 HP	40 HP	50 HP	60 HP	
6F26 (x3)	460	25A	25A	50A	50A	80A	80A	125A	125A	125A	
	575	20A	20A	30A	30A	80A	80A	80A	125A	125A	
0-100A are Class J Fast Acting 110-200A are Class T Fast Acting											

**Table 71. Filter data**

Unit Model	Filters																	
	Standard 2" High Eff Throwaways				90-95% Bag Filters with Prefilters				90-95% Cartridge Filters with Prefilters				90-95% Low Pressure Drop Cartridge Filters					
	Qty	Size of Each	Face Area (ft <sup>2</sup> )	Pre-filters Qty	Pre-filters Size	Qty	Size	Face Area (ft <sup>2</sup> )	Prefilters Qty	Prefilters Size	Qty	Size	Face Area (ft <sup>2</sup> )	Prefilters Qty	Prefilters Size	Qty	Size	Face Area (ft <sup>2</sup> )
90	21	20x24x2	80	21	20x24x2	21	20x24x19	80	21	20x24x2	21	20x24x12	80	21	20x24x2	21	20x24x12	80
	5	15x24x2		5	12x24x2	5	12x24x19		5	12x24x2	5	12x24x12		5	12x24x2	5	12x24x12	
105	21	20x24x2	80	21	20x24x2	21	20x24x19	80	21	20x24x2	21	20x24x12	80	21	20x24x2	21	20x24x12	80
	5	15x24x2		5	12x24x2	5	12x24x19		5	12x24x2	5	12x24x12		5	12x24x2	5	12x24x12	
120	28	20x24x2	93	21	20x24x2	21	20x24x19	80	21	20x24x2	21	20x24x12	80	21	20x24x2	21	20x24x12	80
	5			5	12x24x2	5	12x24x19		5	12x24x2	5	12x24x12		5	12x24x2	5	12x24x12	
130	28	20x24x2	93	21	20x24x2	21	20x24x19	80	21	20x24x2	21	20x24x12	80	21	20x24x2	21	20x24x12	80
	5			5	12x24x2	5	12x24x19		5	12x24x2	5	12x24x12		5	12x24x2	5	12x24x12	
150	28	20x24x2	93	21	20x24x2	21	20x24x19	80	21	20x24x2	21	20x24x12	80	21	20x24x2	21	20x24x12	80
	5			5	12x24x2	5	12x24x19		5	12x24x2	5	12x24x12		5	12x24x2	5	12x24x12	



**Service and Maintenance**

**Table 72. Final filter data**

Final Filters															
Unit Model	90-95% 90-95% Low Pressure Drop Cartridge Filters					90-95% Bag Filters with Prefilters					90-95% Cartridge Filters with Prefilters				
	Pre-filters		Low PD Cartridge Filters			Prefilters		Bag Filters			Prefilters		Cartridge Filters		
	Qty	Size	Qty	Size	Face Area (ft <sup>2</sup> )	Qty	Size	Qty	Size	Face Area (ft <sup>2</sup> )	Qty	Size	Qty	Size	Face Area (ft <sup>2</sup> )
90	15	24x24x4	15	24x24x12	74	15	24x24x2	15	24x24x19	74	15	24x24x2	15	24x24x12	74
	7	12x24x4	7	12x24x12		7	12x24x2	7	12x24x19		7	12x24x2	7	12x24x12	
105	15	24x24x4	15	24x24x12	74	15	24x24x2	15	24x24x19	74	15	24x24x2	15	24x24x12	74
	7	12x24x4	7	12x24x12		7	12x24x2	7	12x24x19		7	12x24x2	7	12x24x12	
120	15	24x24x4	15	24x24x12	74	15	24x24x2	15	24x24x19	74	15	24x24x2	15	24x24x12	74
	7	12x24x4	7	12x24x12		7	12x24x2	7	12x24x19		7	12x24x2	7	12x24x12	
130	15	24x24x4	15	24x24x12	74	15	24x24x2	15	24x24x19	74	15	24x24x2	15	24x24x12	74
	7	12x24x4	7	12x24x12		7	12x24x2	7	12x24x19		7	12x24x2	7	12x24x12	
150	15	24x24x4	15	24x24x12	74	15	24x24x2	15	24x24x19	74	15	24x24x2	15	24x24x12	74
	7	12x24x4	7	12x24x12		7	12x24x2	7	12x24x19		7	12x24x2	7	12x24x12	
Unit Model	90-95% 90-95% High Temp Cartridge Filters with Prefilters					HEPA Filters with Prefilters					High Temp HEPA Filters with Prefilters				
	Pre-filters		High Temp Cartridge Filters			Prefilters		HEPA Filters			Prefilters		High HEPA Temp Filters		
	Qty	Size	Qty	Size	Face Area (ft <sup>2</sup> )	Qty	Size	Qty	Size	Face Area (ft <sup>2</sup> )	Qty	Size	Qty	Size	Face Area (ft <sup>2</sup> )
90	15	24x24x2	15	24x24x12	74	15	24x24x2	15	24x24x12	74	15	24x24x2	15	24x24x12	74
	7	12x24x2	7	12x24x12		7	12x24x2	7	12x24x12		7	12x24x2	7	12x24x12	
105	15	24x24x2	15	24x24x12	74	15	24x24x2	15	24x24x12	74	15	24x24x2	15	24x24x12	74
	7	12x24x2	7	12x24x12		7	12x24x2	7	12x24x12		7	12x24x2	7	12x24x12	
120	15	24x24x2	15	24x24x12	74	15	24x24x2	15	24x24x12	74	15	24x24x2	15	24x24x12	74
	7	12x24x2	7	12x24x12		7	12x24x2	7	12x24x12		7	12x24x2	7	12x24x12	
130	15	24x24x2	15	24x24x12	74	15	24x24x2	15	24x24x12	74	15	24x24x2	15	24x24x12	74
	7	12x24x2	7	12x24x12		7	12x24x2	7	12x24x12		7	12x24x2	7	12x24x12	
150	15	24x24x2	15	24x24x12	74	15	24x24x2	15	24x24x12	74	15	24x24x2	15	24x24x12	74
	7	12x24x2	7	12x24x12		7	12x24x2	7	12x24x12		7	12x24x2	7	12x24x12	

**Table 73. Grease recommendation**

Recommended Grease for Fan Bearings	Recommended Operating Range
Exxon Unirex #2	-20 °F to 250 °F
Mobil 532	
Mobil SHC #220	
Texaco Premium RB	

**Table 74. Air-cooled condenser—refrigerant coil fin data**

Tons	Coil Type	Coil Fin Config.	Tube Dia.	Coil Rows	Fins per foot	Coil Face Area (sq. ft.)	Tube Type
90	Evaporator	Enhanced	1/2	3	168	73.75	Internally Finned
	Hi-Cap Evap	Enhanced	1/2	5	168	73.75	Internally Finned
	Condenser	Enhanced	25 mm	2	240	134	Microchannel
105	Evaporator	Internally Finned	1/2	4	168	73.75	Internally Finned
	Hi-Cap Evap	Internally Finned	1/2	6	168	73.75	Internally Finned
	Condenser	Enhanced	25 mm	2	240	161	Microchannel

**Table 74. Air-cooled condenser—refrigerant coil fin data (continued)**

Tons	Coil Type	Coil Fin Config.	Tube Dia.	Coil Rows	Fins per foot	Coil Face Area (sq. ft.)	Tube Type
120	Evaporator	Internally Finned	1/2	4	168	106.25	Internally Finned
	Hi-Cap Evap	Internally Finned	1/2	6	168	106.25	Internally Finned
	Condenser	Enhanced	25 mm	2	240	161	Microchannel
130	Evaporator	Internally Finned	1/2	4	168	106.25	Internally Finned
	Hi-Cap Evap	Internally Finned	1/2	6	168	106.25	Internally Finned
	Condenser	Enhanced	25 mm	2	240	161	Microchannel
150	Evaporator	Internally Finned	1/2	6	168	106.25	Internally Finned
	Condenser	Smooth	25 mm	2	240	161	Microchannel

## Fan Belt Adjustment

The supply fan belts and optional exhaust fan belts must be inspected periodically to assure proper unit operation.

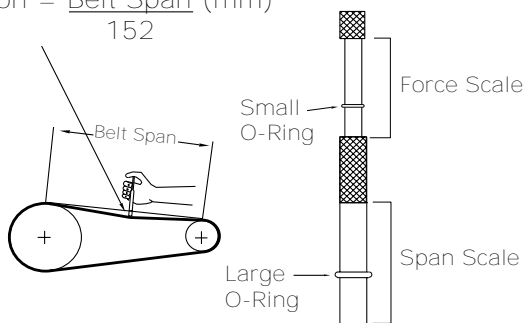
Replacement is necessary if the belts appear frayed or worn. Units with dual belts require a matched set of belts to ensure equal belt length. When removing or installing new belts, do not stretch them over the sheaves; instead, loosen the adjustable motor-mounting base.

Once the new belts are installed, adjust the belt tension using a Browning or Gates tension gauge (or equivalent) illustrated in [Figure 114, p. 175](#).

**Figure 114. Typical belt tension gauge**

$$\text{Deflection} = \frac{\text{Belt Span (in.)}}{64}$$

$$\text{Deflection} = \frac{\text{Belt Span (mm)}}{152}$$



### **⚠ WARNING**

#### **Hazardous Voltage w/Capacitors!**

**Failure to disconnect power and discharge capacitors before servicing could result in death or serious injury.**

**Disconnect all electric power, including remote disconnects and discharge all motor start/run capacitors before servicing. Follow proper lockout/tagout procedures to ensure the power cannot be inadvertently energized. For variable frequency drives or other energy storing components provided by Trane or others, refer to the appropriate manufacturer's literature for allowable waiting periods for discharge of capacitors. Verify with a CAT III or IV voltmeter rated per NFPA 70E that all capacitors have discharged.**

- To determine the appropriate belt deflection:
  - Measure the center-to-center distance, in inches, between the fan sheave and the motor sheave.
  - Divide the distance measured in Step 1a by 64; the resulting value represents the amount of belt deflection for the proper belt tension.
- Set the large O-ring on the belt tension gauge at the deflection value determined in Step 1b.
- Set the small O-ring at zero on the force scale of the gauge.
- Place the large end of the gauge on the belt at the center of the belt span. Depress the gauge plunger until the large O-ring is even with the of the second belt or even with a straightedge placed across the sheaves.
- Remove the tension gauge from the belt. Notice that the small O-ring now indicates a value other than zero on the force scale. This value represents the force (in pounds) required to deflect the belt(s) the proper distance when properly adjusted.
- Compare the force scale reading in step 5 with the appropriate "force" value in . If the force reading is outside of the listed range for the type of belts used, either readjust the belt tension or contact a qualified

service representative.

**Note:** The actual belt deflection force must not exceed the maximum value shown in [Table 75, p. 176](#).

7. Recheck the new belt's tension at least twice during the

first 2 to 3 days of operation. Readjust the belt tension as necessary to correct for any stretching that may have occurred. Until the new belts are "run in", the belt tension will decrease rapidly as they stretch.

**Table 75. Belt tension measurement and deflection ranges**

Belt Cross Section	Smallest Sheave Diameter Range (In.)	RPM Range	Belt Deflection Force (Lbs.)			
			Super Gripbelts and Unnotched Gripbands		Gripnotch Belts and Notched Gripbands	
			Min.	Max.	Min.	Max.
A, AX	3.0-3.6	1000-2500	3.7	5.5	4.1	6.1
	3.8-4.8	1000-2500	4.5	6.8	5	7.4
	5.0-7.0	1000-2500	5.4	8	5.7	8.4
B, BX	3.4 – 4.2	860-2500	–	–	4.9	7.2
	4.4 – 5.6	860-2500	5.3	7.9	7.1	10.5
	5.8 – 8.6	860-2500	6.3	9.4	8.5	12.6
3V, 3VX	2.2 - 2.4	1000-2500	–	–	3.3	4.9
	2.65 - 3.65	1000-2500	3.6	5.1	4.2	6.2
	4.12 - 6.90	1000-2500	4.9	7.3	5.3	7.9
5V, 5VX	4.4 – 6.7	500-1749	–	–	10.2	15.2
		1750-3000	–	–	8.8	13.2
	7.1 – 10.9	500-1740	12.7	18.9	14.8	22.1
	11.8-16.0	500-1740	15.5	23.4	17.1	25.5

## Scroll Compressor Replacement

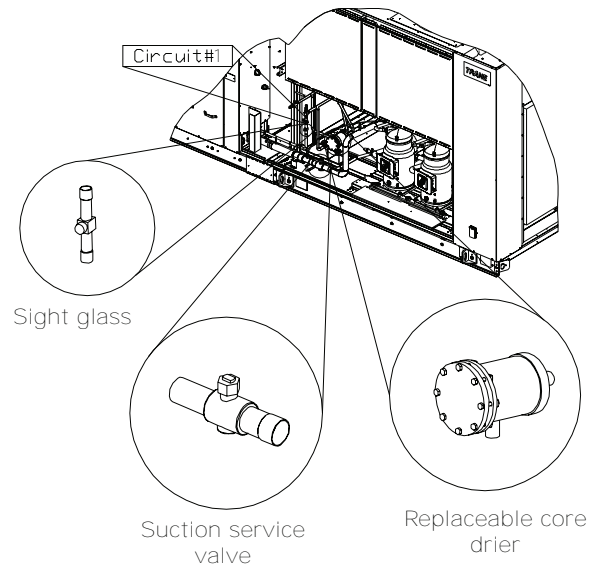
The compressor manifold system was purposely designed to provide proper oil return to each compressor. The refrigerant manifold system must not be modified in any way. See [Figure 115, p. 176](#).

**Note:** Altering the compressor manifold piping may cause oil return problems and compressor failure.

Should a compressor replacement become necessary and a suction line filter drier is to be installed, install it a minimum of 16 or 25 inches upstream of the oil separator tee.

**Important:** Do Not release refrigerant to the atmosphere! If adding or removing refrigerant is required, the service technician must comply with all Federal, State and local laws. Refer to general service bulletin MSCU-SB-1 (latest edition).

**Figure 115. Suction line filter/drier installation**





## Refrigeration System

### **⚠ WARNING**

#### **R-410A Refrigerant under Higher Pressure than R-22!**

Failure to use proper equipment or components as described below, could result in equipment failing and possibly exploding, which could result in death, serious injury, or equipment damage.

The units described in this manual use R-410A refrigerant which operates at higher pressures than R-22. Use **ONLY R-410A** rated service equipment or components with these units. For specific handling concerns with R-410A, please contact your local Trane representative.

### **⚠ WARNING**

#### **Refrigerant under High Pressure!**

Failure to follow instructions below could result in an explosion which could result in death or serious injury or equipment damage.

System contains refrigerant under high pressure. Recover refrigerant to relieve pressure before opening the system. See unit nameplate for refrigerant type. Do not use non-approved refrigerants, refrigerant substitutes, or refrigerant additives.

## Refrigerant Evacuation and Charging

### **NOTICE**

#### **Compressor Damage!**

Failure to follow instructions below result in permanent damage to the compressor. The unit is fully charged with R-410A refrigerant from the factory. However, if it becomes necessary to remove or recharge the system with refrigerant, it is important that the following actions are taken.

The recommended method for evacuation and dehydration is to evacuate both the high side and the low side to 500 microns or less. To establish that the unit is leak-free, use a standing vacuum test. The maximum allowable rise over a 15 minute period is 200 microns. If the rise exceeds this, there is either still moisture in the system or a leak is present.

**Important:** Do Not release refrigerant to the atmosphere! If adding or removing refrigerant is required, the service technician must comply with all federal, state, and local laws.

- To prevent cross contamination of refrigerants and oils, use only dedicated R-410A service equipment.
- Disconnect unit power before evacuation and do not apply voltage to compressor while under vacuum. Failure to follow these instructions will result in compressor failure.
- Due to the presence of POE oil, minimize system open time. Do not exceed 1 hour.
- When recharging R-410A refrigerant, it should be charged in the liquid state.
- The compressor should be off when the initial refrigerant recharge is performed.
- Charging to the liquid line is required prior to starting the compressor to minimize the potential damage to the compressor due to refrigerant in the compressor oil sump at startup.
- If suction line charging is needed to complete the charging process, only do so with the compressor operating. Do not charge liquid refrigerant into the suction line with the compressor off! This increases both the probability that the compressor will start with refrigerant in the compressor oil sump and the potential for compressor damage.
- Allow the crankcase heater to operate a minimum of 8 hours before starting the unit.

## Charge Storage

Due to the reduced capacity of the microchannel condenser coil compared to the round tube plate fin evaporator coil, pumping refrigerant into the condenser coil to service the refrigerant system is no longer an option.

## Compressor Oil

Refer to [Table 76, p. 178](#) for the appropriate scroll compressor oil charge. Remove and measure oil from any compressor replaced. Adjust oil in replacement compressor to prevent excessive oil in system. Anytime a compressor is replaced, the oil for each compressor within the manifold must be replaced.

The scroll compressor uses Trane OIL00079 (one quart container) or OIL00080 (one gallon container) without substitution. Discoloration of the oil indicates that an abnormal condition has occurred. If the oil is dark and smells burnt, it has overheated because of the following:

- Compressor operating at extremely high condensing temperatures

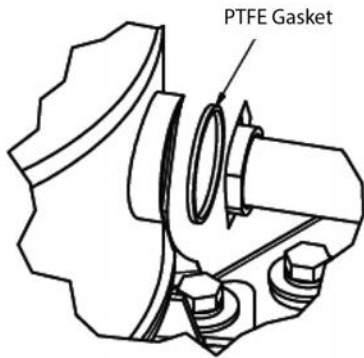
- High superheat
- A compressor mechanical failure
- Occurrence of a motor burnout.

If a motor burnout is suspected, use an acid test kit (KIT15496) to check the condition of the oil. Test results will indicate an acid level has exceeded the limit if a burnout occurred. Oil test kits must be used for POE oil (OIL00079 for a quart container or OIL00080 for a gallon container) to determine whether the oil is acidic. If a motor burnout has occurred, change the oil in both compressors in a tandem set.

**CSHN/CSHL Compressors**

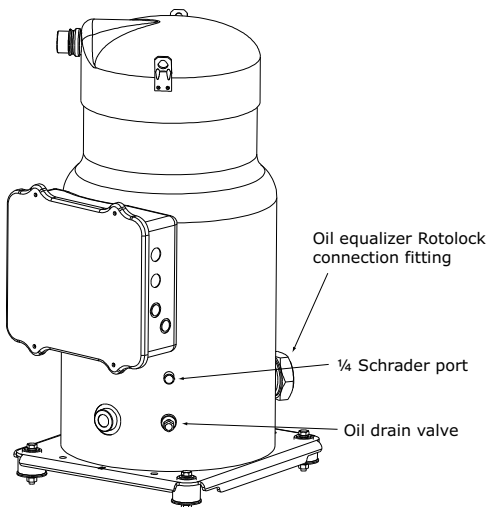
CSHN/CSHL compressors have an oil drain valve which allows the oil to be drained out of the compressor. After the refrigerant has been recovered, pressurize the system with nitrogen to help remove the oil from the compressor.

**Figure 116. PTFE gasket**



Charge the new oil into the Schrader valve or oil drain valve on the shell of the compressor. Due to the moisture absorption properties of POE oil, do not use POE oil from a previously opened container. Also discard any excess oil from the container that is not used.

**Figure 117. CSHN/CSHL**



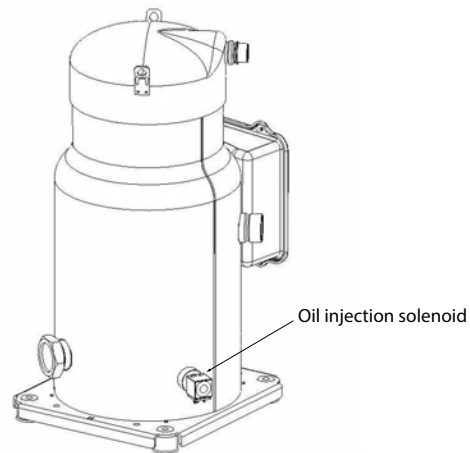
**VZH Variable Speed Compressors**

Refer to “Service and Maintenance\_CSHN Compressors,” p. 178 for VZH117 oil removal procedures.

VZH variable speed compressors include the addition of an oil injection solenoid valve 2QM18 to provide supplemental oil flow from an internal gear pump to the scroll thrust bearing surface. The solenoid is de-energized at low compressor speeds to allow supplemental oil flow and ensure thrust surface lubrication. The solenoid is energized at high compressor speeds to stop supplemental lubrication. This prevents excessive oil circulation to the system. The solenoid is controlled by the inverter and switches at 3300 RPM for the VZH117, and 2700 RPM for the VZH170.

The 115 VAC solenoid coil operation can be checked on one of the solenoid leads with a clamp on amp meter. Above 3300 RPM (VZH117) /2700 RPM (VZH170), the amp meter should read about 0.5 amps to indicate supplemental flow has been stopped.

**Figure 118. Oil injection solenoid valve**



**Table 76. Oil charge per compressor**

Compressor	Pints
CSHN374/CSHL346	15.2
CSHN176-315, CSHL169-285, and VZH170	14.2

**Table 77. Torque requirements for rotolock fittings**

CSHN*/CSHL* and VZH170	100 +/- 10 ft-lbs
------------------------	-------------------

**Note:** Always replace gasket when reassembling oil equalizer lines.

## VFD Programming Parameters (Supply/Return/Exhaust Inverters)

### **⚠ WARNING**

#### **Hazardous Voltage w/Capacitors!**

Failure to disconnect power and discharge capacitors before servicing could result in death or serious injury.

Disconnect all electric power, including remote disconnects and discharge all motor start/run capacitors before servicing. Follow proper lockout/tagout procedures to ensure the power cannot be inadvertently energized. For variable frequency drives or other energy storing components provided by Trane or others, refer to the appropriate manufacturer's literature for allowable waiting periods for discharge of capacitors. Verify with a CAT III or IV voltmeter rated per NFPA 70E that all capacitors have discharged.

Units shipped with an optional variable frequency drive (VFD) are preset and run tested at the factory. If a problem with a VFD occurs, ensure that the programmed parameters listed in [Table 78, p. 180](#) and [Table 79, p. 182](#) have been set before replacing the drive.

#### **Verify Parameters**

Verify parameter 1-23 is set to 60 Hz.

1. To check parameter 1-23 press the Main Menu button twice (if TR150 drive) (press the Back button if the main menu does not display)
2. Scroll down to Load & Motor, press OK
3. Select 1-2, press OK
4. Press down until parameter 1-23 is displayed. Parameter 1-23 can then be modified by pressing OK and pressing the Up and Down buttons.
5. When the desired selection has been made, press OK.

Should replacing the VFD become necessary, the replacement is not configured with all of Trane's operating parameters. The VFD must be programmed before attempting to operate the unit.

To verify and/or program a VFD, use the following steps:

1. At the unit, turn the 115 volt control circuit switch to the Off position.
2. Turn the 24 volt control circuit switch to the Off position.

### **⚠ WARNING**

#### **Hazardous Voltage w/Capacitors!**

Failure to disconnect power and discharge capacitors before servicing could result in death or serious injury.

Disconnect all electric power, including remote disconnects and discharge all motor start/run capacitors before servicing. Follow proper lockout/tagout procedures to ensure the power cannot be inadvertently energized. For variable frequency drives or other energy storing components provided by Trane or others, refer to the appropriate manufacturer's literature for allowable waiting periods for discharge of capacitors. Verify with a CAT III or IV voltmeter rated per NFPA 70E that all capacitors have discharged.

*Important: HIGH VOLTAGE IS PRESENT AT TERMINAL BLOCK OR UNIT DISCONNECT SWITCH.*

3. To modify parameters:
  - a. Press Main Menu twice (if TR150 drive) (press Back if the main menu does not display)
  - b. Use the Up and Down buttons to find the parameter menu group (first part of parameter number)
  - c. Press OK
  - d. Use the Up and Down buttons to select the correct parameter sub-group (first digit of second part of parameter number)
  - e. Press OK
  - f. Use the Up and Down buttons to select the specific parameter
  - g. Press OK
  - h. To move to a different digit within a parameter setting, use the Left and Right buttons (Highlighted area indicates digit selected for change)
  - i. Use the Up and Down buttons to adjust the digit
  - j. Press Cancel to disregard change, or press OK to accept change and enter the new setting
4. Repeat [Step 3](#) for each menu selection setting in [Table 78, p. 180](#) and [Table 79, p. 182](#).
5. To reset all programming parameters back to the factory defaults:
  - a. Go to parameter 14-22 Operation Mode
  - b. Press OK
  - c. Select Initialization
  - d. Press OK
  - e. Cut off the mains supply and wait until the display turns off.
  - f. Reconnect the mains supply - the frequency converter is now reset.
  - g. Ensure parameter 14-22 Operation Mode has reverted back to "Normal Operation".

**Notes:**

- Item 5 resets the drive to the default factory settings. The program parameters listed in [Table 78, p. 180](#) and [Table 79, p. 182](#) will need to be verified or changed as described in Items 3 and 4.
- Some of the parameters listed in the table are motor specific. Due to various motors and efficiencies available, use only the values stamped on the specific motor nameplate. Do not use the Unit nameplate values.
- A backup copy of the current setup may be saved to the LCP before changing parameters or resetting the drive. See

*LCP Copy in the VFD Operating Instructions for details.*

6. Follow the start-up procedures for supply fan in the “Variable Air Volume System” section or the “Relief Airflow Measurement” start-up procedures for the relief fan.
7. After verifying that the VFD(s) are operating properly, press the STOP key to stop the unit operation.
8. Follow the applicable steps in the “Final Unit Checkout” section to return the unit to its normal operating mode.

If a problem with a VFD occurs, ensure that the programmed parameters listed for supply and relief VFD have been set before replacing the drive.

**Table 78. Supply fan VDF programming parameters**

Menu	ID	Description	Parameter Setting
Operation Display	0-01	Language	[0] English US
	0-03	Regional Settings	[1] North American
	0-06	Grid Type	Set to applicable unit power supply [102] 200-240V/60HZ for 208 & 230V/60HZ units [122] 440-480V/60Hz for 460V/60Hz units [132] 525-600V/60Hz for 575V/60Hz units [12] 380-440V/50Hz for 380 & 415V/50Hz supply For IT Grid (no ground connections) or Corner grounded Delta power supply systems, the applicable voltage/Hz and IT-Grid or Delta should be selected.
	0-40	[Hand on] - Key on LCP	[0] Disabled
Load and Motor	1-20	Motor Power [HP]	Per Motor Nameplate HP
	1-22	Motor Voltage (V)	Per Motor Nameplate Voltage
	1-23	Motor Frequency (HZ)	Per Motor Nameplate Frequency
	1-24	Motor Current (A)	Per Motor Nameplate FLA
	1-25	Motor Nominal Speed (RPM)	Per Motor Nameplate Rated Speed
	1-73	Flying Start	[1] Enabled
	1-90	Motor Thermal Protection	[4] ETR Trip1
Brakes	2-00	DC Hold / Preheat Current (%)	[0] 0%
	2-01	DC Brake Current (%)	[0] 0%
	2-04	DC Brake Cut In Speed (HZ)	[10] 10Hz
Reference/ramps	3-02	Minimum Reference (HZ)	[22] 22 Hz
	3-03	Maximum Reference (HZ)	[50] 50 Hz - 380/50Hz SUPPLY ONLY [60] 60 Hz
	3-15	Reference 1 Source	[11] Local bus reference
	3-16	Reference 2 Source	[0] No function
	3-17	Reference 3 Source	[0] No function
	3-41	Ramp 1 Ramp Up Time (S)	[30] 30s
	3-42	Ramp 1 Ramp Down Time (S)	[30] 30s

**Table 78. Supply fan VDF programming parameters (continued)**

Menu	ID	Description	Parameter Setting
Limits/warnings	4-12	Motor Speed Low Limit [HZ]	[22] 22 Hz
	4-14	Motor Speed High Limit (Hz)	[50] 50 Hz - 380/50Hz Supply Only [60] 60 Hz
	4-18	Current Limit (%)	[100] 100%
	4-19	Max Output Frequency (Hz)	[50] 50 Hz - 380/50Hz Supply Only [60] 60 Hz
Digital in/out	5-10	Terminal 18 Digital Input	[0] No Operation
	5-12	Terminal 27 Digital Input	[0] No Operation
	5-13	Terminal 29 Digital Input	[0] No Operation
Communications and Options	8-30	Protocol	[2] Modbus RTU
	8-31	Address	[7] For SUPPLY FAN 4M12
	8-32	Baud Rate	[7] 115200 Baud
	8-33	Parity / Stop Bits	[0] Even Parity, 1 Stop Bits
	8-35	Minimum Response Delay (s)	[0.005] 5ms Min Response Delay Time
	8-36	Maximum Response Delay (s)	[0.1] 100ms Max Response Delay Time
	8-01	Control Site	[2] Controlword onlly
	8-03	Control Timeout Time (s)	[15] 15s
	8-04	Control Timeout Function	[2] Stop
Special Function	14-01	Switching Frequency (kHz)	[5] 5.0 KHz
	14-11	Mains Voltage Fault level	Set based on motor nameplate voltage [177] for 208V motor [196] for 230V motor [323] for 380V motor [353] for 415V motor [391] for 460V motor [489] for 575V motor
	14-12	Function at Main Imbalance	[3] Derate
	14-20	Reset Mode	[5] Automatic reset x 5
	14-50	RFI Filter	[0] Off
	14-61	Function at Inverter Overload	[1] Derate
Application Function	22-60	Broken Belt Function	[2] Trip
	22-61	Broken Belt Torque (%)	[10] 10%
	22-62	Broken Belt Delay (s)	[60] 60 Seconds

**Table 79. Return/relief fan VFD parameters.**

Menu	ID	Description	Parameter Setting
Operation Display	0-01	Language	[0] English US
	0-03	Regional Settings	[1] North American
	0-06	Grid Type	Set to applicable unit power supply [102] 200-240V/60Hz for 208 & 230V/60Hz units [122] 440-480V/60Hz for 460V/60Hz units [132] 525-600V/60Hz for 575V/60Hz units [12] 380-440v/50Hz for 380 & 415V/50Hz supply For IT Grid (no ground connections) or Corner grounded Delta power supply systems, the applicable voltage/Hz and IT-Grid or Delta should be selected.
	0-40	[Hand on] - Key on LCP	[0] Disabled
Load and Motor	1-20	Motor Power (KW/HP)	Per Motor Nameplate HP - KW
	1-22	Motor Voltage (V)	Per Motor Nameplate Voltage
	1-23	Motor Frequency (HZ)	Per Motor Nameplate Frequency
	1-24	Motor Current (A)	Per Motor Nameplate FLA
	1-25	Motor Nominal Speed (RPM)	Per Motor Nameplate Rated Speed
	1-73	Flying Start	[1] Enabled
	1-90	Motor Thermal Protection	[4] ETR Trip1
Brakes	2-00	DC Hold / Preheat Current (%)	[0] 0%
	2-01	DC Brake Current (%)	[0] 0%
	2-04	DC Brake Cut In Speed	[10] 10 Hz
Reference/ramp	3-02	Minimum Reference (HZ)	[22] 22 Hz
	3-03	Maximum Reference (HZ)	[50] 50 Hz-380V/50Hz Supply Only [60] 60Hz
	3-15	Reference 1 Source	[11] Local bus reference
	3-16	Reference 2 Source	[0] No function
	3-17	Reference 3 Source	[0] No function
	3-41	Ramp 1 Ramp up Time (S)	[30] 30s
	3-42	Ramp 1 Ramp down Time (S)	[30] 30s
Limits/warnings	4-10	Motor Speed Direction	[0] Clockwise
	4-12	Motor Speed Low Limit [HZ]	[22] 22 Hz
	4-14	Motor Speed High Limit (Hz)	[50] 50 Hz-380V/50Hz Supply Only [60] 60Hz
	4-18	Current Limit (%)	[100] 100%
	4-19	Max Output Frequency (Hz)	[50] 50 Hz-380V/50Hz Supply Only [60] 60Hz
Digital in/out	5-10	Terminal 18 Digital Input	[0] No Operation
	5-12	Terminal 27 Digital Input	[0] No Operation
	5-13	Terminal 29 Digital Input	[0] No Operation

**Table 79. Return/relief fan VFD parameters. (continued)**

Menu	ID	Description	Parameter Setting
Communications and Operations	8-30	Protocol	[2] Modbus RTU
	8-31	Address	[9] = Relief Fan 6M14 (Digit 17=0,G,H,5,J,6,7,K,8) [12] = Return Fan Fan 6M14 (Digit 17=L,M,C,N,D,E,P,F)
	8-32	Baud Rate	[7] 115200 Baud
	8-33	Parity / Stop Bits	[0] Even Parity,1 Stop Bits
	8-35	Minimum Response Delay (s)	[0.005] 5ms Min Response Delay Time
	8-36	Maximum Response Delay (s)	[0.1] 100ms Max Response Delay Time
	8-01	Control Site	[2] Controlword only
	8-03	Control Timeout Time (s)	[15] 15s
	8-04	Control Timeout Function	[2] Stop
Special Functions	14-01	Switching Frequency (kHz)	[5] 5.0 kHz
	14-11	Mains Voltage Fault level (V)	Set based on motor nameplate voltage [177] for 208V motor [196] for 230V motor [323] for 380V motor [353] for 415V motor [391] for 460V motor [489] for 575V motor
	14-12	Function at Main Imbalance	[3] Derate
	14-20	Reset Mode	[3] Automatic reset x 3
	14-50	RFI Filter	[0] Off
	14-61	Function at Inverter Overload	[1] Derate
Application Functions	22-60	Broken Belt Function	[2] Trip
	22-61	Broken Belt Torque (%)	[10] 10%
	22-62	Broken Belt Delay (s)	[60] 60 Seconds

## eFlex™ Compressor VFD Programming Parameters

### **⚠ WARNING**

#### **Hazardous Voltage w/Capacitors!**

Failure to disconnect power and discharge capacitors before servicing could result in death or serious injury.

Disconnect all electric power, including remote disconnects and discharge all motor start/run capacitors before servicing. Follow proper lockout/tagout procedures to ensure the power cannot be inadvertently energized. For variable frequency drives or other energy storing components provided by Trane or others, refer to the appropriate manufacturer's literature for allowable waiting periods for discharge of capacitors. Verify with a CAT III or IV voltmeter rated per NFPA 70E that all capacitors have discharged.

replacement VFDs. Do not use any other type or brand of VFD when replacing the VFD.

**Note:** Failure to set parameter 4-18 Current Limit on a field replacement VFD will not allow the compressor to start and result in A18 Start Failed or A49 Speed Limit on the VFD.

To verify and/or set parameters in the Compressor VFD:

1. Press **Quick Menu**.
2. Press **My Personal Menu**.
3. Navigate through the options using the **Up** and **Down** arrows to parameter.
4. Adjust the value as shown in [Table 80, p. 184](#) and [Table 81, p. 184](#).
5. Press [OK].

A factory-shipped TRV200 should not be modified in the field. It is specifically matched to the compressor.

Should replacing a VFD become necessary, refer to . All other parameters will be appropriately set in field



## Service and Maintenance

**Table 80. Compressor VFD parameters**

Menu	ID	Description	Parameter Setting
Communications and Options	8-01	Control Site	[2] Control word Only
	8-30	Protocol	[2] Modbus RTU
	8-31	Address	[3]
	8-32	Baud Rate	[7] 115200

**Table 81. Compressor VFD programming parameter 4-18**

TRV200 Drive Current Limit (Parameter 4-18)	
Intellipak 2 Unit	200-600V
S*HJ90	105%
S*HJ105	110%
S*HJ120	110%
S*HJ130	110%
S*HJ150	110%

**Note:** Parameter '4-18 Current Limit' for field installed TRV200 drives must be set according to the table for proper operation and to meet overload protection requirements. Replacement drive will not run the compressor until set properly. Factory installed drives are programmed properly for unit operation. Parameter 4-18 is available via the quick menu.

## Monthly Maintenance

### ⚠ WARNING

#### Hazardous Voltage w/Capacitors!

Failure to disconnect power and discharge capacitors before servicing could result in death or serious injury.

Disconnect all electric power, including remote disconnects and discharge all motor start/run capacitors before servicing. Follow proper lockout/tagout procedures to ensure the power cannot be inadvertently energized. For variable frequency drives or other energy storing components provided by Trane or others, refer to the appropriate manufacturer's literature for allowable waiting periods for discharge of capacitors. Verify with a CAT III or IV voltmeter rated per NFPA 70E that all capacitors have discharged.

Before completing the following checks, turn the unit **OFF** and lock the main power disconnect switch open.

## Filters

Inspect the return air and final filters. Clean or replace them if necessary. Refer to the Service and Maintenance chapter for filter information.

## Cooling Season

### ⚠ WARNING

#### Hazardous Voltage!

Failure to disconnect power before servicing could result in death or serious injury.

Disconnect all electric power, including remote disconnects before servicing. Follow proper lockout/tagout procedures to ensure the power can not be inadvertently energized. Verify that no power is present with a voltmeter.

- Check the unit's drain pans and condensate piping to ensure that there are no blockages.
- Inspect the evaporator and condenser coils for dirt, bent fins, etc. If the coils appear dirty, clean them according to the instructions described in "Coil Cleaning" later in this section.
- Inspect the F/A-R/A damper hinges and pins to ensure that all moving parts are securely mounted. Keep the blades clean as necessary.

### ⚠ WARNING

#### Rotating Components!

Failure to disconnect power before servicing could result in rotating components cutting and slashing technician which could result in death or serious injury.

During installation, testing, servicing and troubleshooting of this product it may be necessary to work with live and exposed rotating components. Have a qualified or licensed service individual who has been properly trained in handling exposed rotating components, perform these tasks.

- Manually rotate the condenser fans to ensure free movement and check motor bearings for wear. Verify that all of the fan mounting hardware is tight.
- Verify that all damper linkages move freely; lubricate with white grease, if necessary.
- Check supply fan motor bearings; repair or replace the motor as necessary.
- Check the fan shaft bearings for wear. Replace the bearings as necessary.

**Note:** These bearings are considered permanently lubricated for normal operation. For severe dirty applications, if relubrication becomes necessary, use a lithium based grease. See [Table 73](#), p. 174 for recommended greases.



**Important:** *The bearings are manufactured using a special synthetic lithium-based grease designed for long life and minimum relube intervals. Over lubrication can be just as harmful as not enough.*

- Use a hand grease gun to lubricate these bearings; add grease until a light bead appears all around the seal. Do not over lubricate! After greasing the bearings, check the setscrews to ensure that the shaft is held securely to the bearings and fan wheels. Make sure that all bearing braces are tight.
- Check the supply fan belt(s). If the belts are frayed or worn, replace them. Refer to the “Fan Belt Adjustment,” p. 175 for belt replacement and adjustments.
- Check the condition of the gasket around the control panel doors. These gaskets must fit correctly and be in good condition to prevent water leakage.
- Verify that all wire terminal connections are tight.
- Remove any corrosion present on the exterior surfaces of the unit and repaint these areas.
- Generally inspect the unit for unusual conditions (e.g., loose access panels, leaking piping connections, etc.)
- Make sure that all retaining screws are reinstalled in the unit access panels once these checks are complete.
- With the unit running, check and record the following:
  - ambient temperature
  - compressor oil level (each circuit)
  - compressor suction and discharge pressures (each circuit)
  - superheat and subcooling (each circuit)

Record this data on an “operator’s maintenance log” like the one shown in [Table 83, p. 188](#). If the operating pressures indicate a refrigerant shortage, measure the system superheat and system subcooling. For guidelines, refer to “Charging by Subcooling,” p. 159.

**Important:** *Do not release refrigerant to the atmosphere! If adding or removing refrigerant is required, the service technician must comply with all federal, state and local laws. Refer to general service bulletin MSCU-SB-1 (latest edition).*

## Heating Season

### **⚠ WARNING**

#### **Hazardous Voltage!**

Failure to disconnect power before servicing could result in death or serious injury.

Disconnect all electric power, including remote disconnects before servicing. Follow proper lockout/tagout procedures to ensure the power can not be inadvertently energized. Verify that no power is present with a voltmeter.

Before completing the following checks, turn the unit **OFF** and lock the main power disconnect switch open.

- Inspect the unit air filters. If necessary, clean or replace them.
- Check supply fan motor bearings; repair or replace the motor as necessary.
- Check the fan shaft bearings for wear. Replace the bearings as necessary.

**Note:** *These bearing are considered permanently lubricated for normal operation. For severe dirty applications, if relubrication becomes necessary, use a lithium based grease. See [Table 73, p. 174](#) for recommended greases.*

**Important:** *The bearings are manufactured using a special synthetic lithium-based grease designed for long life and minimum relube intervals. Over lubrication can be just as harmful as not enough.*

- Use a hand grease gun to lubricate these bearings; add grease until a light bead appears all around the seal. Do not over lubricate!
- After greasing the bearings, check the setscrews to ensure that the shaft is held securely. Make sure that all bearing braces are tight.
- Inspect both the main unit control panel and heat section control box for loose electrical components and terminal connections, as well as damaged wire insulation. Make any necessary repairs.
- Gas units only - Check the heat exchanger(s) for any corrosion, cracks, or holes.
- Check the combustion air blower for dirt or blockage from animals or insects. Clean as necessary.

**Note:** *Typically, it is not necessary to clean the gas furnace. However, if cleaning does become necessary, remove the burner inspection plate from the back of the heat exchanger to access the drum. Be sure to replace the existing gaskets with new ones before reinstalling the inspection plate.*

- Open the main gas valve and apply power to the unit heating section; then initiate a “Heat” test using the startup procedure described in “,” p. 160.

### ⚠ WARNING

#### Hazardous Gases and Flammable Vapors!

Failure to observe the following instructions could result in exposure to hazardous gases, fuel substances, or substances from incomplete combustion, which could result in death or serious injury. The state of California has determined that these substances may cause cancer, birth defects, or other reproductive harm. Improper installation, adjustment, alteration, service or use of this product could cause flammable mixtures or lead to excessive carbon monoxide. To avoid hazardous gases and flammable vapors follow proper installation and setup of this product and all warnings as provided in this manual.

- Verify that the ignition system operates properly.

## Coil Cleaning

Regular coil maintenance, including annual cleaning enhances the unit's operating efficiency by minimizing the following:

- Compressor head pressure and amperage draw
- Water carryover
- Fan brake horsepower
- Static pressure losses

At least once each year—or more often if the unit is located in a “dirty” environment—clean the evaporator, microchannel condenser, and reheat coils using the instructions outlined below. Be sure to follow these instructions as closely as possible to avoid damaging the coils.

### ⚠ WARNING

#### Hazardous Chemicals!

Failure to follow this safety precaution could result in death or serious injury. Coil cleaning agents can be either acidic or highly alkaline and can burn severely if contact with skin or eyes occurs.

Handle chemical carefully and avoid contact with skin. ALWAYS wear Personal Protective Equipment (PPE) including goggles or face shield, chemical resistant gloves, boots, apron or suit as required. For personal safety refer to the cleaning agent manufacturer's Materials Safety Data Sheet and follow all recommended safe handling practices.

## Refrigerant Coils

To clean refrigerant coils, use a soft brush and a sprayer.

**Important:** DO NOT use any detergents with microchannel condenser coils. Pressurized water or air ONLY.

For evaporator and reheat coil cleaners, contact the local Trane Parts Center for appropriate detergents.

1. Remove enough panels from the unit to gain safe access to coils.
2. Straighten any bent coil fins with a fin comb.
3. For accessible areas, remove loose dirt and debris from both sides of the coil. For dual row microchannel condenser coil applications, seek pressure coil wand extension through the local Trane Parts Center.
4. When cleaning evaporator and reheat coils, mix the detergent with water according to the manufacturer's instructions. If desired, heat the solution to 150° F maximum to improve its cleansing capability.

**Important:** DO NOT use any detergents with microchannel coils. Pressurized water or air ONLY.

5. Pour the cleaning solution into the sprayer. If a high-pressure sprayer is used:
  - a. The minimum nozzle spray angle is 15 degrees.
  - b. Do not allow sprayer pressure to exceed 600 psi.
  - c. Spray the solution perpendicular (at 90 degrees) to the coil face.
  - d. For evaporator and reheat coils, maintain a minimum clearance of 6" between the sprayer nozzle and the coil. For microchannel condenser coils, optimum clearance between the sprayer nozzle and the microchannel coil is 1"-3".
6. Spray the leaving-airflow side of the coil first; then spray the opposite side of the coil. For evaporator and reheat coils, allow the cleaning solution to stand on the coil for five minutes.
7. Rinse both sides of the coil with cool, clean water.
8. Inspect both sides of the coil; if it still appears to be dirty, repeat Steps 6 and 7.
9. Reinstall all of the components and panels removed in Step 1; then restore power to the unit.
10. For evaporator and reheat coils, use a fin comb to straighten any coil fins which were inadvertently bent during the cleaning process.

## Steam or Hot Water Coils

To clean a steam or hot water coil, use a soft brush, a steam-cleaning machine, and water.

1. Verify that switches 1S1 and 1S70 are turned “OFF”, and that the main unit disconnect is locked open.

### ⚠ WARNING

#### No Step Surface!

Failure to follow instruction below could result in death or serious injury.

Do not walk on the sheet metal drain pan. Walking on the drain pan could cause the supporting metal to collapse and result in the operator/technician falling.

2. Remove enough panels and components from the unit to gain sufficient access to the coil.
3. Straighten any bent coil fins with a fin comb. (Use the data in [Table 74](#), p. 174 to determine the appropriate fin comb size.)
4. Remove loose dirt and debris from both sides of the coil with a soft brush.
5. Use the steam-cleaning machine to clean the leaving-air side of the coil first; start at the top of the coil and work downward; then clean the entering-air side of the coil, starting at the top of the coil and working downward.
6. Check both sides of the coil; if it still appears dirty, repeat Step 5.

7. Reinstall all of the components and panels removed in Step 2; then restore power to the unit.

## Microchannel Condenser Coil Repair and Replacement

If microchannel condenser coil repair or replacement is required, refer to General Service Bulletin RT-SVB83\*-EN for further details.

### Final Process

Record the unit data in the blanks provided.

**Table 82. Unit data log**

Complete Unit Model Number:	
Unit Serial Number:	
Unit "DL" Number ("design special" units only):	
Wiring Diagram Numbers (from unit control panel):	
-schematic(s)	
-connections	
Network ID (LCI/BCI):	



Service and Maintenance

Table 83. Sample maintenance log

Date	Current Ambient Temp F/C	Refrigerant Circuit #1						Refrigerant Circuit #2						
		Compr. Oil Level	Suct. Press. Psig/kPa	Disch. Press. Psig/kPa	Liquid Press. Psig/kPa	Super-heat F/C	Sub-cool F/C	Compr. Oil Level	Suct. Press. Psig/kPa	Disch. Press. Psig/kPa	Liquid Press. Psig/kPa	Super-heat F/C	Sub-cool F/C	
		-ok -low						-ok -low						
		-ok -low						-ok -low						
		-ok -low						-ok -low						
		-ok -low						-ok -low						
		-ok -low						-ok -low						
		-ok -low						-ok -low						
		-ok -low						-ok -low						
		-ok -low						-ok -low						
		-ok -low						-ok -low						
		-ok -low						-ok -low						
		-ok -low						-ok -low						
		-ok -low						-ok -low						
		-ok -low						-ok -low						
		-ok -low						-ok -low						
		-ok -low						-ok -low						



# Unit Wiring Diagram Numbers

*Note: Wiring diagrams can be accessed via e-Library by entering the diagram number in the literature order number search field or by calling technical support.*

Schematic Number	Description	Sheet Number
<b>Power Schematics</b>		
12134655	POWER SCHEMATIC; 90-150T AIRFLOW, WITH BYPASS	Sheet 1
12134656	POWER SCHEMATIC; 90-150T AIRFLOW, WITHOUT BYPASS	Sheet 1
12134657	POWER SCHEMATIC; 90-150T REF POWER, E-FLEX	Sheet 2
12134658	POWER SCHEMATIC; 90-150T REF POWER, FIXED SPD, STD AMBIENT	Sheet 2
12134659	POWER SCHEMATIC; 90-150T REF POWER, FIXED SPD, LOW AMBIENT	Sheet 2
12134660	POWER SCHEMATIC; 90-150T SERVICE LIGHTS	Sheet 3
<b>Controls Schematics</b>		
12134649	CONTROLS SCHEMATIC; 90-150T UNIT CONTROLS	Sheet 4
12134650	CONTROLS SCHEMATIC; 90-150T CUSTOMER CONNECTIONS #1	Sheet 5
12134651	CONTROLS SCHEMATIC; 90-150T CUSTOMER CONNECTIONS #2	Sheet 6
12134652	CONTROLS SCHEMATIC; 90-150T FIXED SPEED REF SYSTEM #1	Sheet 7
12134653	CONTROLS SCHEMATIC; 90-150T VARIABLE SPEED REF SYSTEM #1	Sheet 7
12134654	CONTROLS SCHEMATIC; 90-150T REF SYSTEM #2	Sheet 8
<b>Return Controls Schematics</b>		
12134645	CONTROLS SCHEMATIC; 90-150T AIR HANDLER CONTROLS #1	Sheet 9
12134646	CONTROLS SCHEMATIC; 90-150T AIR HANDLER CONTROLS #2	Sheet 10
12134647	CONTROLS SCHEMATIC; 90-150T AIR HANDLER CONTROLS #3	Sheet 11
12134648	CONTROLS SCHEMATIC; 90-150T AIR HANDLER CONTROLS #4	Sheet 12
<b>Gas Heat Schematics</b>		
12134680	SCHEMATIC; GAS HEAT	Sheet 13
<b>Electric Heat Schematics</b>		
12134661	SCHEMATIC; ELECTRIC HEAT 90KW	Sheet 13
12134662	SCHEMATIC; ELECTRIC HEAT 140KW	Sheet 13
12134663	SCHEMATIC; ELECTRIC HEAT 265KW	Sheet 13
12134664	SCHEMATIC; ELECTRIC HEAT 300KW	Sheet 13
<b>Hydronic Heat Schematics</b>		
12134681	SCHEMATIC; HYDRONIC HEAT	Sheet 13
<b>Layout Diagrams</b>		
12134682	COMPONENT LAYOUT; 90-150T MAIN C-BOX	Sheet 14
12134683	COMPONENT LAYOUT; 90-150T UNIT DEVICE LOCATIONS	Sheet 15
12134684	COMPONENT LAYOUT; 90-150T SUPPLY & COMPRESSOR VFD	Sheet 16
12134685	COMPONENT LAYOUT; 90-150T VFD & RETURN BOX	Sheet 17
12134686	COMPONENT LAYOUT; GAS HEAT	Sheet 18
12134687	COMPONENT LAYOUT; 90-140KW ELECTRIC HEAT	Sheet 18
12134688	COMPONENT LAYOUT; 265-300KW ELECTRIC HEAT	Sheet 18
12134689	COMPONENT LAYOUT; FUSE REPLACEMENT TABLES	Sheet 19



# Warranty and Liability Clause

## COMMERCIAL EQUIPMENT - 20 TONS AND LARGER AND RELATED ACCESSORIES

PRODUCTS COVERED - This warranty\* is extended by Trane Inc. and applies only to commercial equipment rated 20 Tons and larger and related accessories.

The Company warrants for a period of 12 months from initial startup or 18 months from date of shipment, whichever is less, that the Company products covered by this order (1) are free from defects in material and workmanship and (2) have the capacities and ratings set forth in the Company's catalogs and bulletins, provided that no warranty is made against corrosion, erosion or deterioration. The Company's obligations and liabilities under this warranty are limited to furnishing f.o.b. factory or warehouse at Company designated shipping point, freight allowed to Buyer's city (or port of export for shipment outside the conterminous United States) replacement equipment (or at the option of the Company parts therefore) for all Company products not conforming to this warranty and which have been returned to the manufacturer. The Company shall not be obligated to pay for the cost of lost refrigerant. No liability whatever shall attach to the Company until said products have been paid for and then said liability shall be limited to the purchase price of the equipment shown to be defective.

The Company makes certain further warranty protection available on an optional extra-cost basis. Any further warranty must be in writing, signed by an officer of the Company.

The warranty and liability set forth herein are in lieu of all other warranties and liabilities, whether in contract or in negligence, express or implied, in law or in fact, including implied warranties of merchantability and fitness for particular use. In no event shall the Company be liable for any incidental or consequential damages.

THE WARRANTY AND LIABILITY SET FORTH HEREIN ARE IN LIEU OF ALL OTHER WARRANTIES AND LIABILITIES, WHETHER IN CONTRACT OR IN NEGLIGENCE, EXPRESS OR IMPLIED, IN LAW OR IN FACT, INCLUDING IMPLIED WARRANTIES OF MERCHANTABILITY AND FITNESS FOR PARTICULAR USE, IN NO EVENT SHALL WARRANTOR BE LIABLE FOR ANY INCIDENTAL OR CONSEQUENTIAL DAMAGES.

Manager - Product Service

Trane

Clarksville, Tn 37040-1008

PW-215-2688

\*A 10 year limited warranty is provided on optional Full Modulation Gas Heat Exchanger.

\*Optional Extended Warranties are available for compressors and heat exchangers of Combination Gas-Electric Air Conditioning Units.

\*A 5 year limited warranty is provided for optional "AMCA 1A Ultra Low Leak" airfoil blade economizer assemblies and the "AMCA 1A Ultra Low Leak" economizer actuator.



Trane - by Trane Technologies (NYSE: TT), a global innovator - creates comfortable, energy efficient indoor environments for commercial and residential applications. For more information, please visit [trane.com](http://trane.com) or [tranetechnologies.com](http://tranetechnologies.com).

Trane has a policy of continuous product and product data improvements and reserves the right to change design and specifications without notice. We are committed to using environmentally conscious print practices.