



Integration Guide

Modbus[®] Integration to IntelliPak[®] Rooftop Units With Symbio[™] 800 Controls



⚠ SAFETY WARNING

Only qualified personnel should install and service the equipment. The installation, starting up, and servicing of heating, ventilating, and air-conditioning equipment can be hazardous and requires specific knowledge and training. Improperly installed, adjusted or altered equipment by an unqualified person could result in death or serious injury. When working on the equipment, observe all precautions in the literature and on the tags, stickers, and labels that are attached to the equipment.



Introduction

Read this manual thoroughly before operating or servicing this unit.

Warnings, Cautions, and Notices

Safety advisories appear throughout this manual as required. Your personal safety and the proper operation of this machine depend upon the strict observance of these precautions.

The three types of advisories are defined as follows:



Indicates a potentially hazardous situation which, if not avoided, could result in death or serious injury.



Indicates a potentially hazardous situation which, if not avoided, could result in minor or moderate injury. It could also be used to alert against unsafe practices.



Indicates a situation that could result in equipment or property-damage only accidents.

Important Environmental Concerns

Scientific research has shown that certain man-made chemicals can affect the earth's naturally occurring stratospheric ozone layer when released to the atmosphere. In particular, several of the identified chemicals that may affect the ozone layer are refrigerants that contain Chlorine, Fluorine and Carbon (CFCs) and those containing Hydrogen, Chlorine, Fluorine and Carbon (HCFCs). Not all refrigerants containing these compounds have the same potential impact to the environment. Trane advocates the responsible handling of all refrigerants-including industry replacements for CFCs and HCFCs such as saturated or unsaturated HFCs and HCFCs.

Important Responsible Refrigerant Practices

Trane believes that responsible refrigerant practices are important to the environment, our customers, and the air conditioning industry. All technicians who handle refrigerants must be certified according to local rules. For the USA, the Federal Clean Air Act (Section 608) sets forth the requirements for handling, reclaiming, recovering and recycling of certain refrigerants and the equipment that is used in these service procedures. In addition, some states or municipalities may have additional requirements that must also be adhered to for responsible management of refrigerants. Know the applicable laws and follow them.

⚠ WARNING

Proper Field Wiring and Grounding Required!

Failure to follow code could result in death or serious injury.

All field wiring MUST be performed by qualified personnel. Improperly installed and grounded field wiring poses FIRE and ELECTROCUTION hazards. To avoid these hazards, you MUST follow requirements for field wiring installation and grounding as described in NEC and your local/state/national electrical codes.

⚠ WARNING

Personal Protective Equipment (PPE) Required!

Failure to wear proper PPE for the job being undertaken could result in death or serious injury. Technicians, in order to protect themselves from potential electrical, mechanical, and chemical hazards, **MUST** follow precautions in this manual and on the tags, stickers, and labels, as well as the instructions below:

- Before installing/servicing this unit, technicians **MUST** put on all PPE required for the work being undertaken (Examples; cut resistant gloves/sleeves, butyl gloves, safety glasses, hard hat/bump cap, fall protection, electrical PPE and arc flash clothing). **ALWAYS** refer to appropriate Safety Data Sheets (SDS) and OSHA guidelines for proper PPE.
- When working with or around hazardous chemicals, **ALWAYS** refer to the appropriate SDS and OSHA/GHS (Global Harmonized System of Classification and Labelling of Chemicals) guidelines for information on allowable personal exposure levels, proper respiratory protection and handling instructions.
- If there is a risk of energized electrical contact, arc, or flash, technicians **MUST** put on all PPE in accordance with OSHA, NFPA 70E, or other country-specific requirements for arc flash protection, **PRIOR** to servicing the unit. **NEVER PERFORM ANY SWITCHING, DISCONNECTING, OR VOLTAGE TESTING WITHOUT PROPER ELECTRICAL PPE AND ARC FLASH CLOTHING. ENSURE ELECTRICAL METERS AND EQUIPMENT ARE PROPERLY RATED FOR INTENDED VOLTAGE.**

⚠ WARNING

Follow EHS Policies!

Failure to follow instructions below could result in death or serious injury.

- All Trane personnel must follow the company's Environmental, Health and Safety (EHS) policies when performing work such as hot work, electrical, fall protection, lockout/tagout, refrigerant handling, etc. Where local regulations are more stringent than these policies, those regulations supersede these policies.
- Non-Trane personnel should always follow local regulations.

Copyright

This document and the information in it are the property of Trane, and may not be used or reproduced in whole or in part without written permission. Trane reserves the right to revise this publication at any time, and to make changes to its content without obligation to notify any person of such revision or change.

Trademarks

All trademarks referenced in this document are the trademarks of their respective owners.

Revision History

Updates to the Object Data Points and Diagnostic Data Points section.



Table of Contents

Overview	5
Purpose	5
Symbio™ 800 Controller Overview	5
Communication Options	5
Units of Measure	5
Communication Setup and Configuration	6
Service Tool for Symbio™ 800 Configuration	6
Connecting to the Symbio™ 800 Web Interface	7
Modbus Protocol Configuration	8
Modbus Protocol Settings	8
Modbus Wiring	9
Modbus TCP (Ethernet)	9
Points List	11
Object Naming Conventions	11
Object Data Points and Diagnostic Data Points	11
Symbio™ 800 Controller Layout	A-1



Overview

Purpose

The purpose of this document is to provide instructions for integrating the Symbio™ 800 controller into building automation systems. This document is targeted to system integrators and controls contractors.

Symbio™ 800 Controller Overview

The Symbio™ 800 controller has been installed, programmed, wired, and tested in the factory prior to shipment. While some sensors and end devices are normally wired in the field, nearly all other wiring is factory-provided. Power for the controller is provided and connected from within the RTU control panel.

The RTU and associated controller can be applied as standalone or as part of a building automation system.

Note: For communicating applications to third-party control systems, network communication wiring must be provided by others.

Communication Options

The Symbio™ 800 controller supports the following communication protocol options for integration to either Trane or Non-Trane control systems:

- BACnet MS/TP
- BACnet Zigbee (Air-Fi)®
- BACnet IP
 - Ethernet
 - Wi-Fi
- Modbus RTU
- Modbus TCP
- LonTalk®

For information pertaining to the integration of the Symbio™ 800 controller using either BACnet® or LonTalk® communication, refer to ACC-SVP02*–EN (BACnet) and BAS-SVP039*–EN (LonTalk).

Units of Measure

The communicated data of the Symbio™ 800 controller will be passed in the factory-configured units of measure, either inch-pound (I-P) or the International System of Units (SI). The units of measure are selected as part of the unit order (the default selection is normally I-P). Should the units of measure need to be changed in the field, contact your local Trane representative.

The Symbio™ 800 controller provides a browser-based user interface for USB connection to the controller. One of the tools provided with that interface allows the user to change and customize the Data Display Units Preferences.

Important: These adjustable settings are applied only to the units of measured displayed in the web interface, not the communicated interface.

Regardless of the communicated (system) units of measure, the user may change the displayed units of measure on their smart device. These user preference units of measure are independent of the communicated units.



Communication Setup and Configuration

The Symbio™ 800 controller can be factory ordered with a specific protocol configuration and rotary address setting. If communication options were not specified, the Symbio™ 800 controller will be setup for BACnet MS/TP communications at 76,800 bps with a rotary address setting of 000.

Figure 1. Symbio™ 800 rotary address and service tool port

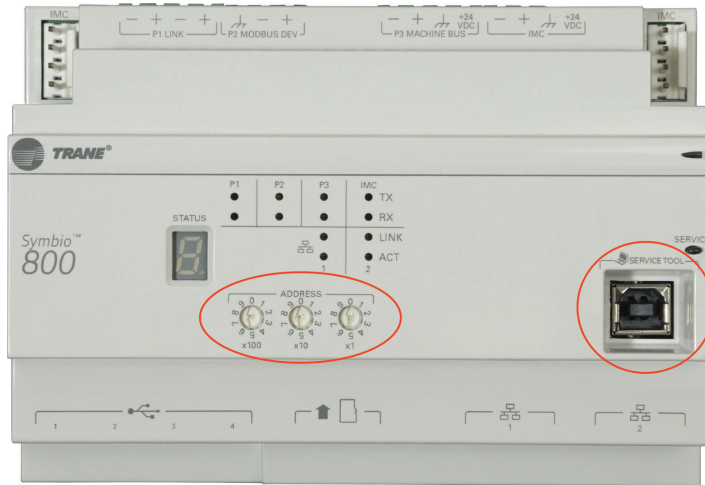

Service Tool for Symbio™ 800 Configuration

The service tool used to modify the Symbio™ 800 controller is a standard web browser. The Symbio™ 800 webpage is accessed by using a standard USB type A/B cable. Connect the USB cable between a laptop and the service tool port on the Symbio™ 800 controller (shown in [Figure 1, p. 6](#)).

Connecting to the Symbio™ 800 Web Interface

1. Connect a laptop to the Symbio™ 800 controller using a USB cable.
2. On the laptop, open a web browser to <http://198.80.18.1/>
3. When the Symbio™ 800 page displays, click **Log In**.

Figure 2. Symbio™ 800 log in screen

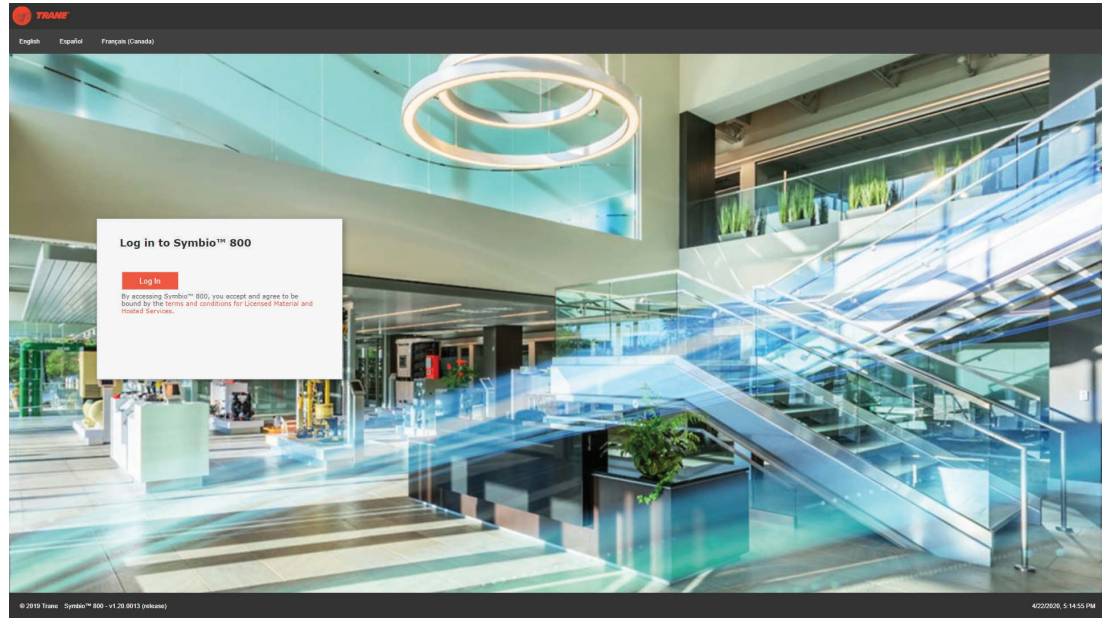

Note: The Symbio™ 800 web interface can only be viewed using the USB connection. Ethernet port 1 and Ethernet port 2 will not allow access to the Symbio™ web server to meet IT security requirements.

Modbus Protocol Configuration

To access the Symbio™ 800 Protocol Configuration page:

1. Connect to the Symbio™ 800 web interface.
2. On the left-hand navigation, click **Installation**.
3. Click **Identification and Communications**.

Figure 3. Identification and Communications

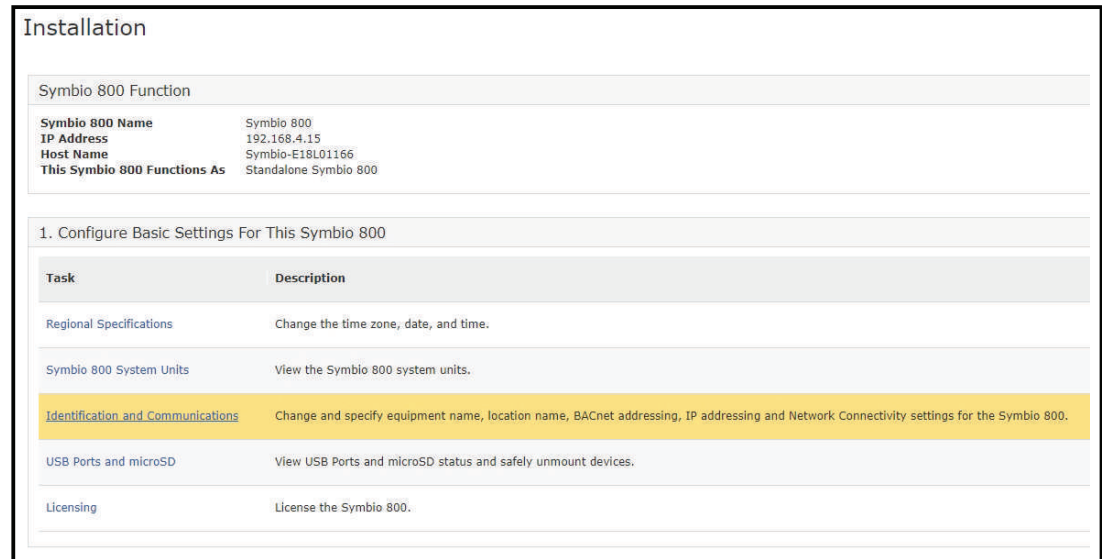

4. Click the **Protocol Configuration** tab.

Figure 4. Protocol Configuration



5. View the existing Protocol Configuration settings.

Modbus Protocol Settings

The rotary address on the Symbio™ 800 controller sets the Modbus address, sometimes called a device ID. Each Modbus server controller on the same Modbus RTU link must have a unique address. The valid range of Modbus RTU server addresses for the Symbio™ 800 is: **001 – 247**.

Important: Symbio™ 800 controller will disable Modbus RTU communications if the rotary address is 000! Changing the rotary address will immediately take affect and does NOT require a power cycle to the Symbio™ 800 controller.

Figure 5. Modbus protocol settings

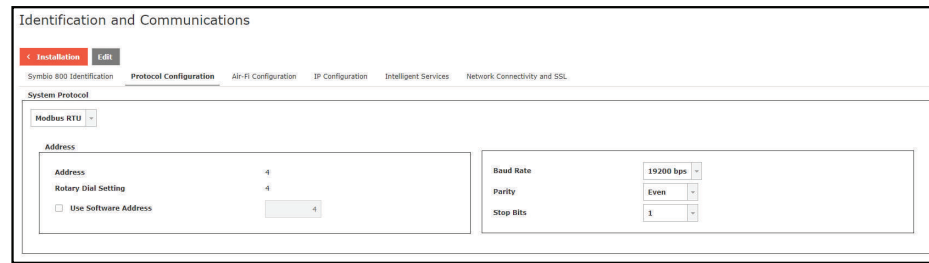

1. Set the Communication Protocol drop down to **Modbus RTU**.
2. The rotary dial setting field shows the physical setting of the rotary dials on the Symbio™ 800. The address field shows the Modbus RTU address. The Modbus RTU address will match the rotary dial setting unless the Use Software address option is used. The recommendation is to change the Modbus address using the physical rotary dials on the Symbio™ 800 controller.
3. Verify the baud rate (default is 19200 bps), parity (default is Even), and stop bits (default is 1). All Modbus RTU devices on a link must communicate using the same communication parameters.

Modbus Wiring

The Modbus RTU communication wire is connected to the P1 Link. Observe wire polarity when connecting to the + and – terminals. The + terminals and the – terminals are internally connected. The second set of + and – terminals on the P1 Link are used to make it easier to wire the next Modbus RTU device in the daisy chain.

Refer to the TIA/EIA 485 standard for detailed information on Modbus RTU wiring.

Modbus TCP (Ethernet)

The Symbio™ 800 controller can communicate Modbus TCP using a standard Ethernet cable. Connect an Ethernet cable with RJ-45 connectors to Ethernet port 1 and the IP network. The Symbio™ 800 controller does not support the optional Wi-Fi module with Modbus TCP communications. The rotary address on the Symbio 800 controller is not used with Modbus TCP communications. Ethernet Port 2 is reserved for the optional TD7 display.

1. Set the System Protocol drop down to **Modbus TCP**.

Figure 6. Set system protocol



2. Click the **IP Configuration** tab to set the IP address of the Symbio™ 800 controller.

Figure 7. Set IP address

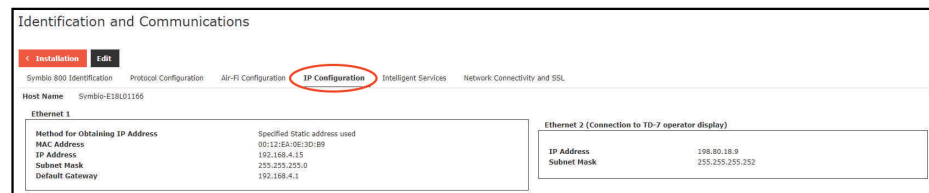

3. Click **Edit**.

Figure 8. Edit IP configuration

Identification and Communications

[< Installation](#) [Edit](#)

[Symbio 800 Identification](#) [Protocol Configuration](#) [Air-Fi Configuration](#) **[IP Configuration](#)** [Intelligent Services](#) [Network Connectivity and SSL](#)

Host Name:

Ethernet 1

Obtain IP Address Automatically using DHCP

Use the following IP address

IP Address:

Subnet Mask:

Default Gateway:

Ethernet 2 (Connection to TD-7 operator display)

IP Address:

Subnet Mask:

4. Setup the Ethernet 1 port to either 'Obtain an IP addresss Automatically using DHCP' or use a static IP address by manually entering the IP address, subnet mask, and default gateway. The IP address information is typically provided by the local IT administrator.
5. Set the Preferred IP Interface to **Ethernet 1**.
6. Set up the DNS section if using a Domain Name System server to identify the Symbio™ 800 controller by host name.



Points List

Object Naming Conventions

The communicated points for the Symbio™ controllers are generally named according to their function. While many of the points are read-only, others include both read and write capability. The established naming convention helps to identify the capabilities of each point. For most points, the suffix identifies the capability according to the following definition.

While there are some exceptions, the majority of the points have been defined according to these guidelines.

Suffix	Description
Status	Points with the Status suffix are defined as read-only. The status point reports the value being used by the controller.
Local	Points with the Local suffix are defined as read-only. The local point reports values associated with controller sensors, both wired and wireless. The local value may or may not be actively used by the controller, depending on the presence or absence of a communicated value (BAS). When both a local and communicated value exist, the communicated value is used.
Active	Points with the Active suffix are defined as read-only. Points designated as active are normally the result of the arbitration between a communicated value(BAS) and at least one value local to the equipment, such as a sensor or default setpoint. The active point reports the value being input to the controller.
Setpoint	Points with the Setpoint suffix are defined as either read-only or read/write. For BACnet, the binary input, analog input and multi-state input points are all read-only. These setpoints report the value currently in use by the controller. The analog value, binary value and multi-state value points are all read/write. These points are provided for use by the building automation system (BAS). When used, these points are written internally to arbitration logic. This defines the interaction with hardwired points, editable software configuration points and the relinquish default value/state. Refer to the Appendix for additional information.
Input	Points with the Input suffix are defined as read-only. These points normally reflect the status of a sensor input, either hardwired or communicating wirelessly (Air-Fi). However, the input point reflects the arbitrated result of the controller sensor input and a communicated value, if present. When both a controller sensor and communicated value exist, the controller will use and report the communicated value.
Arbitrator	Points with the "Arbitrator" suffix are to be used as read-only. The arbitrator prioritizes inputs from communicating points, hardwired points and stored defaults points. The priority array of the arbitration point displays each of the values provided, including the active status, indicating which of the input sources is being used. Refer to the Appendix for additional information.
BAS	Points with the BAS suffix are defined as read/write. These points are provided for use by the building automation system (BAS). When used, these points are written to arbitration logic. This defines the interaction with hardwired points, editable software configuration points and the relinquished default value/state. Refer to the Appendix for additional information.
Command	Points with the Command suffix are defined as read/write. These points are written to change the default behavior of the controller. Once written, these point values may be persisted.
Request	Points with the Request suffix are defined as read/write. These points are written to request a change the operating behavior of the controller.

Object Data Points and Diagnostic Data Points

The following tables are sorted as follows:

- Tables are listed by input/output type and sorted by object identifier. These tables provide the user with the units type for each object type.
- Tables are sorted by object name and provide a complete list of object names, types, values/ ranges, and descriptions.



Points List

Note: Not all points are available to the user. The available data points are defined during configuration and are dependent on equipment profile..

Table 1. Analog input

Object Identifier	Data Type	Object Name	Description	Units	VVDA ^(a)	CVDA ^(b)	VVZT ^(c)	CVZT ^(d)	When Exists
30027	Float (Big-Endian)	Cooling Capacity Status	Indicates the actual operating unit cooling capacity	Percent	X	X	X	X	All Packaged RTU
30095	Float (Big-Endian)	Heating Capacity Primary Status	Indicates the unit (primary) heating capacity	Percent	X	X	X	X	Heat Present
30127	Float (Big-Endian)	Outdoor Air Relative Humidity Local	Indicates the outdoor air humidity value from sensor connected to the controller	Percent	X	X	X	X	Economizer with Reference or Comparative Enthalpy
30121	Float (Big-Endian)	Outdoor Air Flow Local	Indicates the measured outdoor air flow intake to the unit as reported by the locally-wired air flow monitoring feature	Cubic Feet Per Minute	X	X	X	X	TRAQ Present
30173	Float (Big-Endian)	Space Static Pressure Local	Indicates the space static pressure from a sensor connected to the controller	Inches of Water	X	X	X	X	Space Pressure Management Present
30143	Float (Big-Endian)	Return Air Humidity Local	Indicates the return air humidity value from sensor connected to the controller	Percent	X	X	X	X	Economizer with Reference or Comparative Enthalpy
30119	Float (Big-Endian)	Outdoor Air Damper Position	Indicates the position of the outside air damper as requested by the controller. This value does not reflect position feedback from the damper actuator.	Percent	X	X	X	X	Economizer Present
30087	Float (Big-Endian)	Exhaust Damper Position	Indicates the unit exhaust damper position	Percent	X	X	X	X	Barometric or Powered Relief
30125	Float (Big-Endian)	Outdoor Air Minimum Flow Setpoint Active	Indicates the active minimum outdoor air flow setpoint being used by the controller	Cubic Feet Per Minute	X	X	X	X	TRAQ Present
30169	Float (Big-Endian)	Space Humidity Active	Indicates the active space relative humidity being used by the controller	Percent	X	X	X	X	Hot Gas Reheat Present
30327	Float (Big-Endian)	Outdoor Air Dew Point	Indicates the outdoor air dew point value calculated from sensors connected to the controller or BAS values	Degrees Fahrenheit	X	X	X	X	Hot Gas Reheat Present
30129	Float (Big-Endian)	Outdoor Air Temperature Active	Indicates the active outdoor air temperature currently being used by the controller	Degrees Fahrenheit	X	X	X	X	All Packaged RTU
30123	Float (Big-Endian)	Outdoor Air Humidity Active	Indicates the active outdoor air humidity value used by the controller, considering all potential sources, local to the controller and remote	Percent	X	X	X	X	Economizer with Reference or Comparative Enthalpy
30041	Float (Big-Endian)	Discharge Air Cooling Setpoint Active	Indicates the discharge air temperature cooling setpoint value resulting from any setpoint arbitration. The active value does NOT reflect any modifications that may be in place as part of setpoint reset. For the actual value being used, refer to the "...status"	Degrees Fahrenheit	X	X	X	X	All Packaged RTU
30045	Float (Big-Endian)	Discharge Air Heating Setpoint Active	Indicates the discharge air temperature heating setpoint value resulting from any setpoint arbitration. The active value does NOT reflect any modifications that may be in place as part of setpoint reset. For the actual value being used, refer to the "...status"	Degrees Fahrenheit	X	X	X	X	Heat Present
30071	Float (Big-Endian)	Duct Static Pressure Setpoint Active	Indicates the duct static pressure control setpoint value resulting from any setpoint arbitration	Inches of Water	X				Multiple-zone VAV Units
30053	Float (Big-Endian)	Discharge Air Temperature	Indicates the actual discharge air temperature being used by the controller	Degrees Fahrenheit	X	X	X	X	All Packaged RTU
30103	Float (Big-Endian)	Mixed Air Temperature Local	Indicates the mixed air temperature value from a sensor physically connected to the controller	Degrees Fahrenheit	X	X	X	X	All Packaged RTU

Table 1. Analog input (continued)

Object Identifier	Data Type	Object Name	Description	Units	VVDA ^(a)	CVDA ^(b)	VVZT ^(c)	CVZT ^(d)	When Exists
30145	Float (Big-Endian)	Return Air Temperature	Indicates the actual return air temperature being used by the controller	Degrees Fahrenheit	X	X	X	X	Economizer with Reference or Comparative Enthalpy or Rapid Restart
30175	Float (Big-Endian)	Space Static Pressure Setpoint Active	Indicates the active space static pressure being used by the controller	Inches of Water	X	X	X	X	Space Pressure Management Present
30165	Float (Big-Endian)	Space Dehumidification Setpoint Active	Indicates the active (occupied) space dehumidification setpoint, considering all potential sources	Percent	X	X	X	X	Hot Gas Reheat Present
30089	Float (Big-Endian)	Exhaust Fan Speed Status	Indicates the commanded speed of the modulating exhaust fan	Percent	X	X	X	X	Relief/Exhaust Fan Present
30263	Float (Big-Endian)	Return Fan Speed Status	Indicates the unit commanded return fan speed	Percent	X	X	X	X	Return Fan Present
30073	Float (Big-Endian)	Economizer Minimum Position Setpoint Active	Indicates the economizer minimum position setpoint value resulting from any setpoint arbitration	Percent	X	X	X	X	Economizer Present
30069	Float (Big-Endian)	Duct Static Pressure Local	Indicates the duct static pressure value from a sensor physically connected to the controller	Inches of Water	X	X	X	X	All Packaged RTU
30131	Float (Big-Endian)	Outdoor Air Temperature Local	Indicates the outdoor air temperature value from a sensor physically connected to the controller	Degrees Fahrenheit	X	X	X	X	All Packaged RTU
30037	Float (Big-Endian)	Dehumidification Control Status	Indicates the status of the unit dehumidification capacity	Percent	X	X	X	X	Hot Gas Reheat Present
30023	Float (Big-Endian)	Condenser Capacity	Indicates the status of the unit condenser capacity, in percent	Percent	X	X	X	X	All Packaged RTU
30271	Float (Big-Endian)	Energy Recovery Leaving Exhaust Temperature Status	Energy recovery leaving exhaust temperature	Degrees Fahrenheit	X		X		Energy Recovery Wheel
30273	Float (Big-Endian)	Energy Recovery Outdoor Air Bypass Damper Status	Energy recovery outdoor air bypass damper position	Percent	X		X		Energy Recovery Wheel
30267	Float (Big-Endian)	Energy Recovery Exhaust Air Bypass Damper Position	Energy recovery exhaust air bypass damper position	Percent	X		X		Energy Recovery Wheel
30139	Float (Big-Endian)	Reheat Capacity Status	Indicates the unit reheat capacity being requested by the controller, in percent	Percent	X	X	X	X	Hot Gas Reheat Present
30219	Float (Big-Endian)	Supply Fan Speed Status	Indicates the commanded speed of the supply fan, in percent	Percent	X		X		All Packaged RTU
30055	Float (Big-Endian)	Discharge Air Temperature Local	Indicates the discharge air temperature value from a sensor physically connected to the controller	Degrees Fahrenheit	X	X	X	X	All Packaged RTU
30329	Float (Big-Endian)	Outdoor Air Flow Active	Indicates the active outdoor air flow being used by the controller	Cubic Feet Per Minute	X	X	X	X	TRAQ Present
30181	Float (Big-Endian)	Space Temperature Active	Indicates the active space temperature being used by the controller	Degrees Fahrenheit	X	X	X	X	All Packaged RTU
30161	Float (Big-Endian)	Space CO2 Concentration Active	Indicates the active space CO2 concentration being used by the controller	Parts Per Million	X	X	X	X	TRAQ or Demand Control Ventilation
30183	Float (Big-Endian)	Space Temperature Cooling Setpoint Input	Indicates the (occupied) cooling temperature setpoint from the connected space sensor	Degrees Fahrenheit			X	X	Zone Temperature Control Units
30185	Float (Big-Endian)	Space Temperature Heating Setpoint Input	Indicates the (occupied) heating temperature setpoint from the connected space sensor	Degrees Fahrenheit			X	X	Heat Present and Zone Temperature Control Units
30247	Float (Big-Endian)	Heat Type	Identifies the product heat type	No Units	X	X	X	X	All Packaged RTU
30021	Float (Big-Endian)	Cabinet Style	Indicates the cabinet style of the unit	No Units	X	X	X	X	All Packaged RTU



Points List

Table 1. Analog input (continued)

Object Identifier	Data Type	Object Name	Description	Units	VVDA ^(a)	CVDA ^(b)	VVZT ^(c)	CVZT ^(d)	When Exists
30025	Float (Big-Endian)	Cool Type	Indicates the type of cooling in the unit	No Units	X	X	X	X	All Packaged RTU
30137	Float (Big-Endian)	Preheat Type	Indicates the type of preheat in the unit	No Units	X	X	X	X	All Packaged RTU
30141	Float (Big-Endian)	Reheat Type	Indicates the type of reheat in the unit	No Units	X	X	X	X	All Packaged RTU
30221	Float (Big-Endian)	Supply Fan Type	Indicates the type of supply fan in the unit	No Units	X	X	X	X	All Packaged RTU
30091	Float (Big-Endian)	Exhaust Or Return Fan Type	Indicates the type of exhaust fan or return fan in the unit	No Units	X	X	X	X	All Packaged RTU
30249	Float (Big-Endian)	Exhaust Fan Speed Setpoint Active	Active setpoint input to exhaust/relief fan control	Percent	X	X	X	X	Relief/Exhaust Fan Present
30105	Float (Big-Endian)	Number of Circuits	Indicates the number of refrigeration circuits in the unit	No Units	X	X	X	X	All Packaged RTU
30107	Float (Big-Endian)	Number of Compressors Circuit 1	Indicates the number of compressors on DX circuit 1 of the unit	No Units	X	X	X	X	All Packaged RTU
30109	Float (Big-Endian)	Number of Compressors Circuit 2	Indicates the number of compressors on DX circuit 2 of the unit	No Units	X	X	X	X	All Packaged RTU, 40-75T
30147	Float (Big-Endian)	Return Isolation Damper Input	Indicates the requested position of the return isolation damper	Percent	X	X	X	X	Supply or Supply/Return Dampers Present
30163	Float (Big-Endian)	Space CO2 Concentration Input	Indicates the space CO2 concentration from a sensor connected to the controller	Parts Per Million	X	X	X	X	TRAQ or Demand Control Ventilation
30167	Float (Big-Endian)	Space Dehumidification Unoccupied Setpoint Active	Indicates the active unoccupied space dehumidification setpoint, considering all potential sources	Percent	X	X	X	X	Hot Gas Reheat Present
30171	Float (Big-Endian)	Space Humidity Input	Indicates the space relative humidity from a sensor connected to the controller	Percent	X	X	X	X	Hot Gas Reheat Present
30177	Float (Big-Endian)	Space Temp Cooling Setpoint Status	Indicates the (occupied) cooling temperature setpoint from the connected space sensor module	Degrees Fahrenheit			X	X	Zone Temperature Control Units
30179	Float (Big-Endian)	Space Temp Heating Setpoint Status	Indicates the (occupied) heating temperature setpoint from the connected space sensor module	Degrees Fahrenheit			X	X	Heat Present and Zone Temperature Control Units
30187	Float (Big-Endian)	Space Temperature Input	Indicates the space temperature from a sensor connected to the controller, either wired or wireless	Degrees Fahrenheit	X	X	X	X	All Packaged RTU
30189	Float (Big-Endian)	Space Temperature Setpoint Active	Indicates the active space temperature setpoint being used by the controller	Degrees Fahrenheit			X	X	Zone Temperature Control Units
30223	Float (Big-Endian)	Supply Isolation Damper Input	Indicates the requested position of the supply isolation damper, when present	Percent	X	X	X	X	Supply or Supply/Return Dampers Present
30015	Float (Big-Endian)	Average Current	Indicates the average current, as reported by the optional power monitoring feature of the product	Amps	X	X	X	X	Power Monitoring Present
30149	Float (Big-Endian)	Run Time - Compressor 1A	Indicates the run time of Compressor 1A	No Units	X	X	X	X	All Packaged RTU
30191	Float (Big-Endian)	Starts - Compressor 1A	Indicates the number of starts for Compressor 1A	No Units	X	X	X	X	All Packaged RTU
30151	Float (Big-Endian)	Run Time - Compressor 1B	Indicates the run time of Compressor 1B	No Units	X	X	X	X	All Packaged RTU, 20-75T
30193	Float (Big-Endian)	Starts - Compressor 1B	Indicates the number of starts for Compressor 1B	No Units	X	X	X	X	All Packaged RTU, 20-75T
30153	Float (Big-Endian)	Run Time - Compressor 1C	Indicates the run time of Compressor 1C	No Units	X	X	X	X	All Packaged RTU, 20-30T
30195	Float (Big-Endian)	Starts - Compressor 1C	Indicates the number of starts for Compressor 1C	No Units	X	X	X	X	All Packaged RTU, 20-30T
30155	Float (Big-Endian)	Run Time - Compressor 2A	Indicates the run time of Compressor 2A	No Units	X	X	X	X	All Packaged RTU, 40-75T
30197	Float (Big-Endian)	Starts - Compressor 2A	Indicates the number of starts for Compressor 2A	No Units	X	X	X	X	All Packaged RTU, 40-75T

Table 1. Analog input (continued)

Object Identifier	Data Type	Object Name	Description	Units	VVDA ^(a)	CVDA ^(b)	VVZT ^(c)	CVZT ^(d)	When Exists
30157	Float (Big-Endian)	Run Time - Compressor 2B	Indicates the run time of Compressor 2B	No Units	X	X	X	X	All Packaged RTU, 40-75T
30199	Float (Big-Endian)	Starts - Compressor 2B	Indicates the number of starts for Compressor 2B	No Units	X	X	X	X	All Packaged RTU, 40-75T
30159	Float (Big-Endian)	Run Time - Compressor 2C	Run Time - Compressor 2C	No Units	X	X	X	X	All Packaged RTU, 40-75T
30201	Float (Big-Endian)	Starts - Compressor 2C	Starts - Compressor 2C	No Units	X	X	X	X	All Packaged RTU, 40-75T
30029	Float (Big-Endian)	Current L1	Indicates the current for line/leg 1, as reported by the optional power monitoring feature of the product	Amps	X	X	X	X	Power Monitoring Present
30031	Float (Big-Endian)	Current L2	Indicates the current for line/leg 2, as reported by the optional power monitoring feature of the product	Amps	X	X	X	X	Power Monitoring Present
30033	Float (Big-Endian)	Current L3	Indicates the current for line/leg 3, as reported by the optional power monitoring feature of the product	Amps	X	X	X	X	Power Monitoring Present
30035	Float (Big-Endian)	Current Neutral	Indicates the current for neutral, as reported by the optional power monitoring feature of the product	Amps	X	X	X	X	Power Monitoring Present
30043	Float (Big-Endian)	Discharge Air Cooling Setpoint Status	Indicates the actual discharge air temperature cooling setpoint value, including all setpoint arbitration and any reset algorithms	Degrees Fahrenheit	X	X			Discharge Air Temperature Control
30047	Float (Big-Endian)	Discharge Air Heating Setpoint Status	Indicates the actual discharge air temperature heating setpoint value, including all setpoint arbitration and any reset algorithms	Degrees Fahrenheit	X	X			Heat Present and Discharge Air Temperature Control
30059	Float (Big-Endian)	Discharge Pressure Circuit 1	Indicates the refrigerant discharge pressure for DX circuit 1, in PSIG	Pounds Per Square Inch	X	X	X	X	All Packaged RTU
30061	Float (Big-Endian)	Discharge Pressure Circuit 2	Indicates the refrigerant discharge pressure for DX circuit 2, in PSIG	Pounds Per Square Inch	X	X	X	X	All Packaged RTU, 40-75T
30077	Float (Big-Endian)	Energy Consumption Lifetime	Indicates the total energy consumption of the unit (for the lifetime of the unit) when the power monitoring feature is included	kWh	X	X	X	X	Power Monitoring Present
30079	Float (Big-Endian)	Evaporator Leaving Air Temperature	Indicates the leaving air temperature of the evaporator	Degrees Fahrenheit	X	X	X	X	Hot Gas Reheat Present
30081	Float (Big-Endian)	Evaporator Leaving Air Temperature Evap A	Indicates the leaving air temperature of evaporator A when a split evaporator is used	Degrees Fahrenheit	X	X	X	X	Hot Gas Reheat Present
30083	Float (Big-Endian)	Evaporator Leaving Air Temperature Evap B	Indicates the leaving air temperature of evaporator B when a split evaporator is used	Degrees Fahrenheit	X	X	X	X	Hot Gas Reheat Present
30085	Float (Big-Endian)	Evaporator Leaving Air Temperature Setpoint Active	Indicates the evaporator leaving air temperature setpoint value resulting from any setpoint arbitration, when applicable	Degrees Fahrenheit	X	X			Hot Gas Reheat Present
30093	Float (Big-Endian)	Final Filter Differential Pressure Local	Indicates the status of the final filter differential pressure sensor input on the controller	Inches of Water	X	X	X	X	Final Filters Present
30097	Float (Big-Endian)	Line Frequency	Indicates the line frequency when the optional power monitoring option is included	No Units	X	X	X	X	Power Monitoring Present
30099	Float (Big-Endian)	Mixed Air Temperature Evap A	Indicates the mixed air temperature associated with evaporator A when a split evaporator is used	Degrees Fahrenheit	X	X	X	X	High-efficiency or Variable Speed Refrigeration System, 70-75T

Points List
Table 1. Analog input (continued)

Object Identifier	Data Type	Object Name	Description	Units	VVDA ^(a)	CVDA ^(b)	VVZT ^(c)	CVZT ^(d)	When Exists
30101	Float (Big-Endian)	Mixed Air Temperature Evap B	Indicates the mixed air temperature associated with evaporator B when a split evaporator is used	Degrees Fahrenheit	X	X	X	X	High-efficiency or Variable Speed Refrigeration System, 70-75T
30133	Float (Big-Endian)	Power Factor	Indicates the reported power factor from the optional power monitoring option, when applicable	No Units	X	X	X	X	Power Monitoring Present
30135	Float (Big-Endian)	Prefilter Differential Pressure Local	Indicates the status of the pre-final filter differential pressure sensor input on the controller	Inches of Water	X	X	X	X	Pre-filters Present
30203	Float (Big-Endian)	Suction Pressure Circuit 1	Indicates the suction pressure for DX circuit 1, in PSIG	Pounds Per Square Inch	X	X	X	X	All Packaged RTU
30205	Float (Big-Endian)	Suction Pressure Circuit 2	Indicates the suction pressure for DX circuit 2, in PSIG	Pounds Per Square Inch	X	X	X	X	All Packaged RTU, 40-75T
30225	Float (Big-Endian)	Total Apparent Energy	Indicates the total apparent energy as reported by the optional power monitoring feature, when present	kWh	X	X	X	X	Power Monitoring Present
30075	Float (Big-Endian)	Energy Consumption	Indicates the total energy consumption of the unit (since last accumulation reset) when the power monitoring feature is included	kWh	X	X	X	X	Power Monitoring Present
30229	Float (Big-Endian)	Total Reactive Energy	Indicates the total reactive energy as reported by the optional power monitoring feature, when present	kWh	X	X	X	X	Power Monitoring Present
30233	Float (Big-Endian)	Total Real Power	Indicates the total real power as reported by the optional power monitoring feature, when present	kW	X	X	X	X	Power Monitoring Present
30227	Float (Big-Endian)	Total Apparent Power	Indicates the total apparent power as reported by the optional power monitoring feature, when present	kW	X	X	X	X	Power Monitoring Present
30231	Float (Big-Endian)	Total Reactive Power	Indicates the total reactive power as reported by the optional power monitoring feature, when present	kW	X	X	X	X	Power Monitoring Present
30039	Float (Big-Endian)	Unit Source ID	Indicates the last diagnostic of the unit. Separately, individual diagnostics are reported with dedicated points, variables, registers	No Units	X	X	X	X	All Packaged RTU
30235	Float (Big-Endian)	Voltage L1-L2	Indicates the voltage between line/leg L1 and L2	Volts	X	X	X	X	Power Monitoring Present
30237	Float (Big-Endian)	Voltage L1-L3	Indicates the voltage between line/leg L1 and L3	Volts	X	X	X	X	Power Monitoring Present
30239	Float (Big-Endian)	Voltage L1-N	Indicates the voltage between line/leg L1 and Neutral	Volts	X	X	X	X	Power Monitoring Present
30241	Float (Big-Endian)	Voltage L2-L3	Indicates the voltage between line/leg L2 and L3	Volts	X	X	X	X	Power Monitoring Present
30243	Float (Big-Endian)	Voltage L2-N	Indicates the voltage between line/leg L2 and Neutral	Volts	X	X	X	X	Power Monitoring Present
30245	Float (Big-Endian)	Voltage L3-N	Indicates the voltage between line/leg L3 and Neutral	Volts	X	X	X	X	Power Monitoring Present
30057	Float (Big-Endian)	Discharge Air Temperature Setpoint Active	Indicates the discharge air temperature setpoint value resulting from any setpoint arbitration	Degrees Fahrenheit	X	X	X	X	All Packaged RTU
30011	Float (Big-Endian)	Air Flow Percentage Circuit 1	Indicates the requested condenser percentage for circuit 1	Percent	X	X	X	X	All Packaged RTU
30013	Float (Big-Endian)	Air Flow Percentage Circuit 2	Indicates the requested condenser percentage for circuit 2	Percent	X	X	X	X	All Packaged RTU, 40-75T
30063	Float (Big-Endian)	Discharge Saturated Refrigeration Temperature Circuit 1	Indicates the discharge saturated refrigerant temperature for DX circuit 2	Degrees Fahrenheit	X	X	X	X	All Packaged RTU

Table 1. Analog input (continued)

Object Identifier	Data Type	Object Name	Description	Units	VVDA ^(a)	CVDA ^(b)	VVZT ^(c)	CVZT ^(d)	When Exists
30065	Float (Big-Endian)	Discharge Saturated Refrigeration Temperature Circuit 2	Indicates the discharge saturated refrigerant temperature for DX circuit 2	Degrees Fahrenheit	X	X	X	X	All Packaged RTU, 40-75T
30207	Float (Big-Endian)	Suction Saturated Refrigerant Temperature Circuit 1	Indicates suction saturated refrigerant temperature for DX circuit 1	Degrees Fahrenheit	X	X	X	X	All Packaged RTU
30209	Float (Big-Endian)	Suction Saturated Refrigerant Temperature Circuit 2	Indicates suction saturated refrigerant temperature for DX circuit 2	Degrees Fahrenheit	X	X	X	X	All Packaged RTU, 40-75T
30211	Float (Big-Endian)	Suction Temperature Evap 1A	Indicates the suction temperature for evaporator 1A	Degrees Fahrenheit	X	X	X	X	High-efficiency or Variable Speed Refrigeration System, 70-75T
30213	Float (Big-Endian)	Suction Temperature Evap 1B	Indicates the suction temperature for evaporator 1B	Degrees Fahrenheit	X	X	X	X	High-efficiency or Variable Speed Refrigeration System, 70-75T
30215	Float (Big-Endian)	Suction Temperature Evap 2A	Indicates the suction temperature for evaporator 2A	Degrees Fahrenheit	X	X	X	X	High-efficiency or Variable Speed Refrigeration System, 70-75T
30217	Float (Big-Endian)	Suction Temperature Evap 2B	Indicates the suction temperature for evaporator 2B	Degrees Fahrenheit	X	X	X	X	High-efficiency or Variable Speed Refrigeration System, 70-75T
30111	Float (Big-Endian)	Occupied Cooling Setpoint	Indicates the active occupied cooling setpoint being used by the controller, considering all possible sources	Degrees Fahrenheit			X	X	Zone Temperature Control Units
30113	Float (Big-Endian)	Occupied Heating Setpoint	Indicates the active occupied heating setpoint being used by the controller, considering all possible sources	Degrees Fahrenheit			X	X	Heat Present and Zone Temperature Control
30115	Float (Big-Endian)	Occupied Standby Cooling Setpoint	Indicates the active occupied standby cooling setpoint being used by the controller, considering all possible sources	Degrees Fahrenheit			X	X	Zone Temperature Control Units
30117	Float (Big-Endian)	Occupied Standby Heating Setpoint	Indicates the active occupied standby heating setpoint being used by the controller, considering all possible sources	Degrees Fahrenheit			X	X	Heat Present and Zone Temperature Control
30251	Float (Big-Endian)	Supply Fan Speed Setpoint Active	Active setpoint input to supply fan control	Percent	X		X		Variable Volume Supply Fan Present
30253	Float (Big-Endian)	Discharge Air Temperature Maximum Cool Limit Active	Indicates maximum cooling setpoint allowed to be calculated by Space Temp Control	Degrees Fahrenheit			X	X	Zone Temperature Control Units
30255	Float (Big-Endian)	Discharge Air Temperature Minimum Heat Limit Active	Indicates minimum heating setpoint allowed to be calculated by Space Temp Control	Degrees Fahrenheit			X	X	Heat Present and Zone Temperature Control
30257	Float (Big-Endian)	Discharge Air Temperature Minimum Cool Limit Active	Indicates minimum cooling setpoint allowed to be calculated by Space Temp Control	Degrees Fahrenheit			X	X	Zone Temperature Control Units
30259	Float (Big-Endian)	Discharge Air Temperature Maximum Heat Limit Active	Indicates minimum heating setpoint allowed to be calculated by Space Temp Control	Degrees Fahrenheit			X	X	Heat Present and Zone Temperature Control
30269	Float (Big-Endian)	Energy Recovery Heating Capacity	Indicates percentage heating capacity of all bypass damper operation during heating.	Percent	X		X		Energy Recovery Wheel



Points List

Table 1. Analog input (continued)

Object Identifier	Data Type	Object Name	Description	Units	VVDA ^(a)	CVDA ^(b)	VVZT ^(c)	CVZT ^(d)	When Exists
30265	Float (Big-Endian)	Energy Recovery Cooling Capacity	Indicates percentage cooling capacity of all bypass damper operation during cooling.	Percent	X		X		Energy Recovery Wheel
30275	Float (Big-Endian)	Energy Recovery Wheel Filter Differential Pressure	Indicates differential pressure across the energy wheel filter	Inches of Water	X		X		Energy Recovery Wheel
30277	Float (Big-Endian)	Average Current Meter 2	Indicates the average current for the second power meter (air handling section), as reported by the optional power monitoring feature of the product	Amps	X	X	X	X	Dual Power Monitoring Present
30279	Float (Big-Endian)	Current L1 Meter 2	Indicates the current for line/leg 1 for the second power meter (air handling section), as reported by the optional power monitoring feature of the product	Amps	X	X	X	X	Dual Power Monitoring Present
30281	Float (Big-Endian)	Current L2 Meter 2	Indicates the current for line/leg 2 for the second power meter (air handling section), as reported by the optional power monitoring feature of the product	Amps	X	X	X	X	Dual Power Monitoring Present
30283	Float (Big-Endian)	Current L3 Meter 2	Indicates the current for line/leg 3 for the second power meter (air handling section), as reported by the optional power monitoring feature of the product	Amps	X	X	X	X	Dual Power Monitoring Present
30285	Float (Big-Endian)	Current Neutral Meter 2	Indicates the current for neutral for the second power meter (air handling section), as reported by the optional power monitoring feature of the product	Amps	X	X	X	X	Dual Power Monitoring Present
30289	Float (Big-Endian)	Energy Consumption Meter 2	Indicates the energy consumption (since last reset) for the second power meter (air handling section), as reported by the optional power monitoring feature of the product	kWh	X	X	X	X	Dual Power Monitoring Present
30287	Float (Big-Endian)	Energy Consumption Lifetime Meter 2	Indicates the energy consumption for the second power meter (air handling section), as reported by the optional power monitoring feature of the product	kWh	X	X	X	X	Dual Power Monitoring Present
30291	Float (Big-Endian)	Line Frequency Meter 2	Indicates the line frequency for the second power meter (air handling section), as reported by the optional power monitoring feature of the product	No Units	X	X	X	X	Dual Power Monitoring Present
30293	Float (Big-Endian)	Power Factor Meter 2	Indicates the power factor for the second power meter (air handling section), as reported by the optional power monitoring feature of the product	No Units	X	X	X	X	Dual Power Monitoring Present
30295	Float (Big-Endian)	Total Apparent Energy Meter 2	Indicates the total apparent energy for the second power meter (air handling section), as reported by the optional power monitoring feature of the product	kWh	X	X	X	X	Dual Power Monitoring Present
30297	Float (Big-Endian)	Total Apparent Power Meter 2	Indicates the total apparent power for the second power meter (air handling section), as reported by the optional power monitoring feature of the product	kW	X	X	X	X	Dual Power Monitoring Present
30299	Float (Big-Endian)	Total Reactive Energy Meter 2	Indicates the total reactive energy for the second power meter (air handling section), as reported by the optional power monitoring feature of the product	kWh	X	X	X	X	Dual Power Monitoring Present

Table 1. Analog input (continued)

Object Identifier	Data Type	Object Name	Description	Units	VVDA ^(a)	CVDA ^(b)	VVZT ^(c)	CVZT ^(d)	When Exists
30301	Float (Big-Endian)	Total Reactive Power Meter 2	Indicates the total reactive power for the second power meter (air handling section), as reported by the optional power monitoring feature of the product	kW	X	X	X	X	Dual Power Monitoring Present
30303	Float (Big-Endian)	Total Real Power Meter 2	Indicates the total real power for the second power meter (air handling section), as reported by the optional power monitoring feature of the product	kW	X	X	X	X	Dual Power Monitoring Present
30305	Float (Big-Endian)	Voltage L1-L2 Meter 2	Indicates the voltage between line/leg L1 and L2 for the second power meter (air handling section), as reported by the optional power monitoring feature of the product	Volts	X	X	X	X	Dual Power Monitoring Present
30307	Float (Big-Endian)	Voltage L1-L3 Meter 2	Indicates the voltage between line/leg L1 and L3 for the second power meter (air handling section), as reported by the optional power monitoring feature of the product	Volts	X	X	X	X	Dual Power Monitoring Present
30309	Float (Big-Endian)	Voltage L1-N Meter 2	Indicates the voltage between line/leg L1 and Neutral for the second power meter (air handling section), as reported by the optional power monitoring feature of the product	Volts	X	X	X	X	Dual Power Monitoring Present
30311	Float (Big-Endian)	Voltage L2-L3 Meter 2	Indicates the voltage between line/leg L2 and L3 for the second power meter (air handling section), as reported by the optional power monitoring feature of the product	Volts	X	X	X	X	Dual Power Monitoring Present
30313	Float (Big-Endian)	Voltage L2-N Meter 2	Indicates the voltage between line/leg L2 and Neutral for the second power meter (air handling section), as reported by the optional power monitoring feature of the product	Volts	X	X	X	X	Dual Power Monitoring Present
30315	Float (Big-Endian)	Voltage L3-N Meter 2	Indicates the voltage between line/leg L3 and Neutral for the second power meter (air handling section), as reported by the optional power monitoring feature of the product	Volts	X	X	X	X	Dual Power Monitoring Present
30330	Float (Big-Endian)	Run Time - Compressor 1A (Hours)	Indicates the run time of Compressor 1A, in hours	No Units	X	X	X	X	All Packaged RTU
30332	Float (Big-Endian)	Run Time - Compressor 1B (Hours)	Indicates the run time of Compressor 1B, in hours	No Units	X	X	X	X	All Packaged RTU, 20-75T
30334	Float (Big-Endian)	Run Time - Compressor 1C (Hours)	Indicates the run time of Compressor 1C, in hours	No Units	X	X	X	X	All Packaged RTU, 20-30T
30336	Float (Big-Endian)	Run Time - Compressor 2A (Hours)	Indicates the run time of Compressor 2A, in hours	No Units	X	X	X	X	All Packaged RTU, 40-75T
30338	Float (Big-Endian)	Run Time - Compressor 2B (Hours)	Indicates the run time of Compressor 2B, in hours	No Units	X	X	X	X	All Packaged RTU, 40-75T
30340	Float (Big-Endian)	Run Time - Compressor 2C (Hours)	Indicates the run time of Compressor 2C, in hours	No Units	X	X	X	X	All Packaged RTU, 40-75T
30342	Float (Big-Endian)	Discharge Absolute Pressure Circuit 1	Indicates the refrigerant discharge pressure for DX circuit 1, in PSIA	Pounds Per Square Inch	X	X	X	X	All Packaged RTU
30344	Float (Big-Endian)	Discharge Absolute Pressure Circuit 2	Indicates the refrigerant discharge pressure for DX circuit 2, in PSIA	Pounds Per Square Inch	X	X	X	X	All Packaged RTU, 40-75T

Points List

Table 1. Analog input (continued)

Object Identifier	Data Type	Object Name	Description	Units	VVDA ^(a)	CVDA ^(b)	VVZT ^(c)	CVZT ^(d)	When Exists
30346	Float (Big-Endian)	Suction Absolute Pressure Circuit 1	Indicates the suction pressure for DX circuit 1, in PSIA	Pounds Per Square Inch	X	X	X	X	All Packaged RTU
30348	Float (Big-Endian)	Suction Absolute Pressure Circuit 2	Indicates the suction pressure for DX circuit 2, in PSIA	Pounds Per Square Inch	X	X	X	X	All Packaged RTU, 40-75T
30320	Float (Big-Endian)	Space Dew Point	Indicates the calculated space dew point from space humid active,space temp active	Degrees Fahrenheit	X	X	X	X	Energy Recovery Wheel
30322	Float (Big-Endian)	Space Dew Point Setpoint Active	Active occupied space dew point setpoint	Degrees Fahrenheit	X	X	X	X	Energy Recovery Wheel
30324	Float (Big-Endian)	Space Dew Point Unocc Setpoint Active	Active unoccupied space dew point setpoint	Degrees Fahrenheit	X	X	X	X	Energy Recovery Wheel
30350	Float (Big-Endian)	Heating Capacity Setpoint Active	Status of current heating capacity request	Percent	X	X	X	X	Energy Recovery Wheel
30352	Float (Big-Endian)	Outdoor Air Damper Position Setpoint Active	Status of current outdoor air damper position request	Percent	X	X	X	X	Economizer Present
30354	Float (Big-Endian)	Return Fan Speed Setpoint Active	Status of current return fan speed request	Percent	X	X	X	X	Return Fan Present
30356	Float (Big-Endian)	Cooling Capacity Setpoint Active	Status of current cooling capacity request	Percent	X	X	X	X	All Packaged RTU

^(a) VVDA - Variable Volume Discharge Air Temperature Control

^(b) CVDA - Constant Volume Discharge Air Temperature Control

^(c) VVZT - Variable Volume Zone Temperature Control

^(d) CVZT - Constant Volume Zone Temperature Control

Table 2. Analog value

Object Identifier	Data Type	Object Name	Description	Units	Valid Range	VVDA ^(a)	CVDA ^(b)	VWZT ^(c)	CVZT ^(d)	When Exists	Last One Wins ^(e)	Heartbeat ^(f)
40027	Float (Big-Endian)	Discharge Air Temperature Arbitrator	Indicates the actual discharge air temperature being used by the controller, as determined by the arbitration logic that considers all possible sources	Degrees Fahrenheit	-40.0 to 200.0°F	X	X			Discharge Air Temperature Control		
40079	Float (Big-Endian)	Outdoor Air Temperature Arbitrator	Indicates the actual outdoor air temperature being used by the controller, as determined by the arbitration logic that considers all possible sources	Degrees Fahrenheit	-40.0 to 200.0°F	X	X	X	X	Economizer Present		
40073	Float (Big-Endian)	Outdoor Air Humidity Arbitrator	Indicates the actual outdoor air humidity being used by the controller, as determined by the arbitration logic that considers all possible sources	Percent	0.0 to 100.0 %	X	X	X	X	Economizer with Reference or Comparative Enthalpy		
40123	Float (Big-Endian)	Outdoor Air Flow Arbitrator	Indicates the actual outdoor air flow being used by the controller, as determined by the arbitration logic that considers all possible sources	Cubic Feet per Minute	0 to 65,535 CFM	X	X	X	X	TRAQ Present		
40103	Float (Big-Endian)	Space Temperature Arbitrator	Indicates the actual space temperature being used by the controller, as determined by the arbitration logic that considers all possible sources	Degrees Fahrenheit	-40.0 to 200.0°F	X	X	X	X	All Packaged RTU		
40085	Float (Big-Endian)	Space CO2 Concentration Arbitrator	Indicates the actual space CO2 concentration being used by the controller, as determined by the arbitration logic that considers all possible sources	Parts Per Million	0 to 65,535 PPM	X	X	X	X	Economizer with TRAQ or Demand Control Ventilation		
40097	Float (Big-Endian)	Space Humidity Arbitrator	Indicates the actual space relative humidity being used by the controller, as determined by the arbitration logic that considers all possible sources	Percent	0.0 to 100.0 %	X	X	X	X	Hot Gas Reheat Present		

Points List
Table 2. Analog value (continued)

Object Identifier	Data Type	Object Name	Description	Units	Valid Range	VVDA ^(a)	CVDA ^(b)	WVZT ^(c)	CVZT ^(d)	When Exists	Last One Wins ^(e)	Heartbeat ^(f)
40029	Float (Big-Endian)	Discharge Air Temperature BAS	The value is normally provided by the BAS to send the discharge air temperature sensor value. The value is subject to arbitration logic in the controller, in which case it may or may not be used for control purposes.	Degrees Fahrenheit	-40.0 to 200.0°F	X	X			Discharge Air Temperature Control	X	▼
40081	Float (Big-Endian)	Outdoor Air Temperature BAS	The value is normally provided by the BAS to send the outdoor air temperature sensor value. The value is subject to arbitration logic in the controller, in which case it may or may not be used for control purposes.	Degrees Fahrenheit	-40.0 to 200.0°F	X	X	X	X	Economizer Present	X	▼
40105	Float (Big-Endian)	Space Temperature BAS	The value is normally provided by the BAS to send the space temperature value. The value is subject to arbitration logic in the controller, in which case it may or may not be used for control purposes.	Degrees Fahrenheit	14.0 to 122.0°F	X	X	X	X	All Packaged RTU	X	▼
40125	Float (Big-Endian)	Outdoor Air Flow BAS	The value is normally provided by the BAS to send the outdoor air flow value. The value is subject to arbitration logic in the controller, in which case it may or may not be used for control purposes.	Cubic Feet per Minute	0 to 65,000 CFM	X	X	X	X	TRAQ Present	X	▼
40075	Float (Big-Endian)	Outdoor Air Humidity BAS	The value is normally provided by the BAS to send the outdoor air humidity sensor value. The value is subject to arbitration logic in the controller, in which case it may or may not be used for control purposes.	Percent	0 to 100%	X	X	X	X	Economizer with Reference or Comparative Enthalpy	X	▼

Table 2. Analog value (continued)

Object Identifier	Data Type	Object Name	Description	Units	Valid Range	VVDA ^(a)	CVDA ^(b)	VWZT ^(c)	CVZT ^(d)	When Exists	Last One Wins ^(e)	Heartbeat ^(f)
40087	Float (Big-Endian)	Space CO2 Concentration BAS	The value is normally provided by the BAS to send the space CO2 concentration value. The value is subject to arbitration logic in the controller, in which case it may or may not be used for control purposes.	Parts Per Million	50 to 5000 PPM	X	X	X	X	Economizer with TRAQ or Demand Control Ventilation	X	▼
40099	Float (Big-Endian)	Space Humidity BAS	The value is normally provided by the BAS to send the space relative humidity value. The value is subject to arbitration logic in the controller, in which case it may or may not be used for control purposes.	Percent	10.0 to 90.0%	X	X	X	X	Hot Gas Reheat Present	X	▼
40021	Float (Big-Endian)	Discharge Air Cooling Setpoint BAS	Normally provided by the BAS to request the discharge air temperature cooling setpoint value	Degrees Fahrenheit	40.0 to 90.0°F	X	X	X	X	All Packaged RTU		
40023	Float (Big-Endian)	Discharge Air Heating Setpoint BAS	Normally provided by the BAS to request the discharge air temperature heating setpoint value	Degrees Fahrenheit	40.0 to 180.0°F	X	X	X	X	Heat Present		
40109	Float (Big-Endian)	Unoccupied Cooling Setpoint	Normally used by the BAS to define the cooling temperature setpoint used for control in unoccupied mode	Degrees Fahrenheit	52.0 to 90.0°F	X	X	X	X	All Packaged RTU	X	
40111	Float (Big-Endian)	Unoccupied Heating Setpoint	Normally used by the BAS to define the heating temperature setpoint used for control in unoccupied mode	Degrees Fahrenheit	52.0 to 90.0°F	X	X	X	X	Heat Present	X	
40077	Float (Big-Endian)	Outdoor Air Minimum Flow Setpoint BAS	Normally provided by the BAS to send the requested minimum outdoor air flow setpoint	Cubic Feet per Minute	0 to 60,000 CFM	X	X	X	X	TRAQ Present		
40107	Float (Big-Endian)	Space Temperature Setpoint BAS	BAS-supplied space temperature setpoint value	Degrees Fahrenheit	50.0 to 95.0°F			X	X	Zone Temperature Control Units		
40101	Float (Big-Endian)	Space Static Pressure Setpoint BAS	The value is normally provided by the BAS to send the space static pressure value. The value is subject to arbitration logic in the controller, in which case it may or may not be used for control purposes.	Inches of Water	-0.2 to 0.3 in. w.c.	X	X	X	X	Space Pressure Management Present		

Table 2. Analog value (continued)

Object Identifier	Data Type	Object Name	Description	Units	Valid Range	VVDA ^(a)	CVDA ^(b)	WZT ^(c)	CVZT ^(d)	When Exists	Last One Wins ^(e)	Heartbeat ^(f)
40065	Float (Big-Endian)	Occupied Offset	This value is normally provided by the BAS to define the difference between the occupied cooling and heating setpoints when a single setpoint is provided (see Space Temperature Setpoint BAS, below).	Delta Degrees Fahrenheit	0.0 to 30.0°F			X	X	Zone Temperature Control Units	X	
40025	Float (Big-Endian)	Discharge Air Reheat Setpoint BAS	Normally provided by the BAS to request the discharge air temperature reheat setpoint value, for dehumidification control	Degrees Fahrenheit	60.0 to 80.0°F	X	X			Discharge Air Temperature Control		
40093	Float (Big-Endian)	Space Dehumidification Setpoint BAS	Normally used by the BAS to define the (occupied) space dehumidification setpoint	Percent	40.0 to 65.0 %	X	X	X	X	Hot Gas Reheat Present		
40113	Float (Big-Endian)	Supply Fan Speed Setpoint	BAS supplied supply fan speed setpoint value	Percent	0.0 to 100.0 %	X		X		Variable Volume Supply Fan Control		
40115	Float (Big-Endian)	Exhaust Fan Speed Setpoint	BAS supplied exhaust fan speed setpoint value	Percent	0.0 to 100.0 %	X	X	X	X	Relief/Exhaust Fan Present		
40011	Float (Big-Endian)	Cooling Capacity Enable	This percentage value is normally provided by the BAS to demand limit the cooling capacity.	Percent	0.0 to 100.0 %	X	X	X	X	All Packaged RTU		
40051	Float (Big-Endian)	Heat Primary Enable BAS	This percentage value is normally provided by the BAS to demand limit the heating capacity.	Percent	0.0 to 100.0 %	X	X	X	X	Heat Present		
40057	Float (Big-Endian)	Morning Warmup Setpoint BAS	Normally provided by the BMS, defines the space temperature below which morning warmup will be exercised, when enabled	Degrees Fahrenheit	50.0 to 90.0°F	X	X	X	X	Heat Present	X	
40071	Float (Big-Endian)	Occupied Standby Offset	This value is normally provided by the BMS to define the difference between the occupied standby cooling and heating setpoints when a single setpoint is provided (see Space Temperature Setpoint BAS, below).	Delta Degrees Fahrenheit	1.0 to 10.0°F				X	Zone Temperature Control Units	X	
40039	Float (Big-Endian)	Duct Static Pressure Setpoint BAS	Normally provided by the BAS to request the duct static pressure setpoint value	Inches of Water	0.7 to 4.3 in. w. c.	X				Multiple-zone VAV Units		

Table 2. Analog value (continued)

Object Identifier	Data Type	Object Name	Description	Units	Valid Range	VVDA ^(a)	CVDA ^(b)	VWZT ^(c)	CVZT ^(d)	When Exists	Last One Wins ^(e)	Heartbeat ^(f)
40041	Float (Big-Endian)	Economizer Minimum Position Setpoint BAS	Normally provided by the BAS to request the economizer minimum position setpoint	Percent	0.0 to 100.0 %	X	X	X	X	Economizer Present		
40013	Float (Big-Endian)	Cooling Setpoint High Limit	The value is normally used by the BAS to provide the occupied cooling setpoint high limit for space comfort control applications.	Degrees Fahrenheit	40.0 to 115.0° F			X	X	Zone Temperature Control Units	X	
40015	Float (Big-Endian)	Cooling Setpoint Low Limit	The value is normally used by the BAS to provide the occupied cooling setpoint low limit for space comfort control applications.	Degrees Fahrenheit	40.0 to 115.0° F			X	X	Zone Temperature Control Units	X	
40017	Float (Big-Endian)	Daytime Warmup Setpoint BAS	Defines the space temp below which daytime warmup will be enabled	Degrees Fahrenheit	50.0 to 87.0° F	X	X			Heat Present and Discharge Temperature Control	X	
40043	Float (Big-Endian)	Economizer Outdoor Air Enable Setpoint BAS	Related to the economizer enable decision, this value is normally provided by the BAS to determine the outdoor air temperature below which economizing is enabled.	Degrees Fahrenheit	50.0 to 140.0° F	X	X	X	X	Economizer Present	X	
40053	Float (Big-Endian)	Heating Setpoint High Limit	The value is normally used by the BAS to provide the occupied heating setpoint high limit for space comfort control applications.	Degrees Fahrenheit	40.0 to 115.0° F			X	X	Heat Present and Zone Temperature Control	X	
40055	Float (Big-Endian)	Heating Setpoint Low Limit	The value is normally used by the BAS to provide the occupied heating setpoint low limit for space comfort control applications.	Degrees Fahrenheit	43.0 to 100.0° F			X	X	Heat Present and Zone Temperature Control	X	
40095	Float (Big-Endian)	Space Dehumidification Unoccupied Setpoint BAS	Normally used by the BAS to define the unoccupied space dehumidification setpoint	Percent	40.0 to 65.0 %	X	X	X	X	Hot Gas Reheat Present		
40061	Float (Big-Endian)	Occupied Cooling Setpoint BAS	The value is normally provided by the BAS to define the occupied cooling setpoint when both heating and cooling setpoints are provided in lieu of a single setpoint	Degrees Fahrenheit	40.0 to 115.0° F			X	X	Zone Temperature Control Units		

Points List
Table 2. Analog value (continued)

Object Identifier	Data Type	Object Name	Description	Units	Valid Range	VVDA ^(a)	CVDA ^(b)	VWZT ^(c)	CVZT ^(d)	When Exists	Last One Wins ^(e)	Heartbeat ^(f)
40063	Float (Big-Endian)	Occupied Heating Setpoint BAS	The value is normally provided by the BAS to define the occupied heating setpoint when both heating and cooling setpoints are provided in lieu of a single setpoint	Degrees Fahrenheit	40.0 to 115.0° F			X	X	Heat Present and Zone Temperature Control		
40067	Float (Big-Endian)	Occupied Standby Cooling Setpoint BAS	The value is normally provided by the BAS to define the occupied standby cooling setpoint when both heating and cooling setpoints are provided in lieu of a single setpoint	Degrees Fahrenheit	40.0 to 115.0° F			X	X	Zone Temperature Control Units		
40069	Float (Big-Endian)	Occupied Standby Heating Setpoint BAS	Indicates the active occupied standby heating setpoint being used by the controller, considering all possible sources	Degrees Fahrenheit	40.0 to 115.0° F			X	X	Heat Present and Zone Temperature Control		
40019	Float (Big-Endian)	Demand Limit Setpoint	This value is normally provided by the BAS to demand limit the unit. Demand Limit Request BAS must be set to "Limited" in order for the value to have meaning.	Percent	-163.84 to 163.83 %	X	X	X	X	All Packaged RTU		
40047	Float (Big-Endian)	Evaporator Leaving Air Temperature Setpoint	Normally provided by the BAS to request the evaporator leaving air temperature setpoint	Degrees Fahrenheit	40 to 55° F	X	X	X	X	Hot Gas Reheat Present		
40083	Float (Big-Endian)	Pre Cool Setpoint	Normally provided by the BAS, defines the space temperature above which pre-cool will be exercised, when enabled	Degrees Fahrenheit	40 to 90° F	X	X	X	X	All Packaged RTU	X	
40031	Float (Big-Endian)	Discharge Air Temperature Maximum Heat Limit	Indicates the discharge air temperature maximum heat limit, above which a high temperature diagnostic will be generated This value can be provided by the BAS.	Degrees Fahrenheit	40 to 140° F			X	X	Heat Present and Zone Temperature Control		
40033	Float (Big-Endian)	Discharge Air Temperature Minimum Cool Limit	Indicates the discharge air temperature minimum cool limit, below which a low temperature diagnostic will be generated This value can be provided by the BAS.	Degrees Fahrenheit	40 to 80° F			X	X	Zone Temperature Control Units		

Table 2. Analog value (continued)

Object Identifier	Data Type	Object Name	Description	Units	Valid Range	VVDA ^(a)	CVDA ^(b)	VWZT ^(c)	CVZT ^(d)	When Exists	Last One Wins ^(e)	Heartbeat ^(f)
40049	Float (Big-Endian)	Exhaust Enable Position Setpoint	Normally provided by the BAS to indicate the outdoor air damper position above which the exhaust sequence is enabled	Percent	0.0 to 100.0 %	X	X	X	X	Relief/Exhaust Fan Present	X	
40059	Float (Big-Endian)	Occupied Bypass Time	Normally used by the BAS to configure the occupied bypass time. The occupied bypass time is the amount of time the controller will be overridden when an occupancy request is initiated during the unoccupied mode.	No Units	0 to 240 minutes	X	X	X	X	All Packaged RTU	X	
40045	Float (Big-Endian)	Economizer Outdoor Air Enthalpy Enable Setpoint	Related to the economizer enable decision, this value is normally provided by the BAS to determine the outdoor air enthalpy below which economizing is enabled.	BTUs per Pound	0 to 80 BTU/ lbm	X	X	X	X	Economizer with Reference or Comparative Enthalpy	X	
40089	Float (Big-Endian)	Space CO2 High Limit	Normally provided by the BAS to define the CO2 high limit, for ventilation purposes	Parts Per Million	0 to 2000 ppm	X	X	X	X	Economizer with TRAQ or Demand Control Ventilation	X	
40091	Float (Big-Endian)	Space CO2 Low Limit	Normally provided by the BAS to define the CO2 low limit	Parts Per Million	0 to 2000 ppm	X	X	X	X	Economizer with TRAQ or Demand Control Ventilation	X	
40117	Float (Big-Endian)	Supply Fan Speed Setpoint External Heat	Specifies the supply fan speed setpoint during external heat modes of operation.	Percent	0.0 to 100.0 %			X		Single-zone VAV	X	
40121	Float (Big-Endian)	Discharge Air Temperature Maximum Cool Limit	Normally used by BAS to limit space temperature control calculated cooling setpoint	Degrees Fahrenheit	39.9 to 80.1°F			X	X	Zone Temperature Control Units		
40119	Float (Big-Endian)	Discharge Air Temperature Minimum Heat Limit	Normally used by BAS to limit space temperature control calculated heating setpoint	Degrees Fahrenheit	39.9 to 140.1°F			X	X	Zone Temperature Control Units w/ Heat		
40127	Float (Big-Endian)	Space Dew Point Setpoint BAS	Normally used by the BAS to define the dew point temperature setpoint used for dehumidification control in occupied mode	Degrees Fahrenheit	40 to 70°F	X	X	X	X	Hot Gas Reheat Present		

Points List
Table 2. Analog value (continued)

Object Identifier	Data Type	Object Name	Description	Units	Valid Range	VVDA ^(a)	CVDA ^(b)	VVZT ^(c)	CVZT ^(d)	When Exists	Last One Wins ^(e)	Heartbeat ^(f)
40129	Float (Big-Endian)	Space Dew Point Unocc Setpoint BAS	Normally used by the BAS to define the dew point temperature setpoint used for dehumidification control in unoccupied mode.	Degrees Fahrenheit	40 to 75°F	X	X	X	X	Hot Gas Reheat Present		
40131	Float (Big-Endian)	Heating Capacity Setpoint External	Remote heating capacity request.	Percent	0.0 to 100.0 %	X	X	X	X	Energy Recovery Wheel	X	▼
40133	Float (Big-Endian)	Outdoor Air Damper Position Setpoint External	Remote outdoor air damper position request.	Percent	0.0 to 100.0 %	X	X	X	X	Economizer Present	X	▼
40135	Float (Big-Endian)	Exhaust Fan Speed Setpoint External	Remote exhaust fan speed request.	Percent	0.0 to 100.0 %	X	X	X	X	Relief/Exhaust Fan Present	X	▼
40137	Float (Big-Endian)	Return Fan Speed Setpoint External	Remote return fan speed request.	Percent	0.0 to 100.0 %	X	X	X	X	Return Fan Present	X	▼
40139	Float (Big-Endian)	Supply Fan Speed Setpoint External	Remote supply fan speed request.	Percent	0.0 to 100.0 %	X	X	X	X	All Packaged RTU	X	▼
40141	Float (Big-Endian)	Cooling Capacity Setpoint External	Remote cooling capacity request.	Percent	0.0 to 100.0 %	X	X	X	X	All Packaged RTU	X	▼

^(a) VVDA - Variable Volume Discharge Air Temperature Control

^(b) CVDA - Constant Volume Discharge Air Temperature Control

^(c) VVZT - Variable Volume Zone Temperature Control

^(d) CVZT - Constant Volume Zone Temperature Control

^(e) Last written value is persisted; not subject to a priority array

^(f) Heartbeat values must be written at least once every 15 minutes (recommend 5 minutes). Arbitrator points are not intended to be written to.

Table 3. Binary input

Object Identifier	Data Type	Object Name	Description	Object States	VVDA ^(a)	CVDA ^(b)	VVZT ^(c)	CVZT ^(d)	When Exists
33053	Signed Int (16-bit)	FDD: Unit Economizing When It Should Not	FDD: Indicates when the unit is economizing but should not be	0 = Inactive 1 = Active	X	X	X	X	Economizer Present
33054	Signed Int (16-bit)	FDD: Unit Not Economizing When it Should Be	FDD: Indicates when the unit is not economizing but should be	0 = Inactive 1 = Active	X	X	X	X	Economizer Present
33050	Signed Int (16-bit)	FDD: Excessive Outdoor Air	FDD: Indicates an excessive outdoor air condition	0 = Inactive 1 = Active	X	X	X	X	Economizer Present
33051	Signed Int (16-bit)	FDD: Outdoor Air Damper Not Modulating	FDD: Indicates when the outdoor air damper is not modulating but should be	0 = Inactive 1 = Active	X	X	X	X	Economizer Present
33015	Signed Int (16-bit)	Compressor 1A Status	Indicates the operating status of compressor 1A	0 = Off 1 = Running	X	X	X	X	All Packaged RTU
33016	Signed Int (16-bit)	Compressor 1B Status	Indicates the operating status of compressor 1B	0 = Off 1 = Running	X	X	X	X	All Packaged RTU, 20-75T
33017	Signed Int (16-bit)	Compressor 1C Status	Indicates the operating status of compressor 1C	0 = Off 1 = Running	X	X	X	X	All Packaged RTU, 20-30T
33018	Signed Int (16-bit)	Compressor 2A Status	Indicates the operating status of compressor 2A	0 = Off 1 = Running	X	X	X	X	All Packaged RTU, 40-75T
33019	Signed Int (16-bit)	Compressor 2B Status	Indicates the operating status of compressor 2B	0 = Off 1 = Running	X	X	X	X	All Packaged RTU, 40-75T
33020	Signed Int (16-bit)	Compressor 2C Status	Indicates the running status of compressor 2C	0 = Off 1 = Running	X	X	X	X	All Packaged RTU, 40-75T
33052	Signed Int (16-bit)	FDD: Outdoor Air Temperature Sensor Failure	FDD: Indicates when the outdoor air temperature sensor has failed	0 = Normal 1 = Outdoor Air Temp Sensor Fail	X	X	X	X	Economizer Present
33069	Signed Int (16-bit)	Unit Running State	Indicates whether the unit is off or on	0 = Off 1 = On	X	X	X	X	All Packaged RTU
33070	Signed Int (16-bit)	VAV Box Command	Indicates whether the associated VAV boxes should be allowed to be in automatic control or forced wide open	0 = Auto 1 = Open	X	X			Multiple-zone VAV Units
33011	Signed Int (16-bit)	Alarm Relay Output Status	Indicates the state of the alarm output of the controller	0 = De-energized 1 = Energized	X	X	X	X	All Packaged RTU
33084	Signed Int (16-bit)	Return Fan Output Status	Indicates the state of the return fan	0 = Off 1 = On	X	X	X	X	Return Fan Present
33077	Signed Int (16-bit)	Supply Fan Configuration Status	Indicates the supply fan configuration	0 = Cycling 1 = Continuous			X	X	Zone Temperature Control Units
33078	Signed Int (16-bit)	Rapid Restart Status	Indicates the active status of the Rapid Restart event	0 = Inactive 1 = Active	X	X	X	X	Rapid Restart Control
33061	Signed Int (16-bit)	Morning Warmup Active	Indicates the active status of the Morning Warmup event	0 = Inactive 1 = Active	X	X	X	X	Heat Present
33030	Signed Int (16-bit)	Daytime Warmup Active	Indicates the active status of the Daytime Warmup event	0 = Inactive 1 = Active	X	X			Discharge Air Temperature Control and Heat Present
33013	Signed Int (16-bit)	Coil Frost Protection Status Circuit 1	Indicates the status of evaporator frost protection function for circuit 1	0 = Inactive 1 = Active	X	X	X	X	All Packaged RTU
33014	Signed Int (16-bit)	Coil Frost Protection Status Circuit 2	Indicates the status of evaporator frost protection function for circuit 2	0 = Inactive 1 = Active	X	X	X	X	All Packaged RTU, 40-75T



Points List

Table 3. Binary input (continued)

Object Identifier	Data Type	Object Name	Description	Object States	VVDA ^(a)	CVDA ^(b)	VVZT ^(c)	CVZT ^(d)	When Exists
33091	Signed Int (16-bit)	Energy Recovery Status	Indicates the status of the energy recovery device (Wheel)	0 = Inactive 1 = Active	X		X		Energy Recovery Wheel
33090	Signed Int (16-bit)	Energy Recovery Preheat Status	Indicates the status of the energy recovery preheat	0 = Inactive 1 = Active	X		X		Energy Recovery Wheel
33089	Signed Int (16-bit)	Energy Recovery Frost Avoidance Status	Indicates the status of the Recovery Frost Avoidance function	0 = Inactive 1 = Active	X		X		Energy Recovery Wheel
33021	Signed Int (16-bit)	Condensate Overflow Input	Indicates the status of the condensate overflow input	0 = Normal 1 = Overflow	X	X	X	X	Condensate Overflow Switch Present
33062	Signed Int (16-bit)	Occupancy Input	Indicates the status of the occupancy input (see below)	0 = Occupied 1 = Unoccupied	X	X	X	X	All Packaged RTU
33063	Signed Int (16-bit)	Precool Active	Indicates when the precool mode is active	0 = Inactive 1 = Active	X	X	X	X	All Packaged RTU
33064	Signed Int (16-bit)	Supply Air Tempering Status	Indicates whether or not the supply air tempering feature is enabled	0 = Disabled 1 = Enabled	X	X			Modulating Gas Heat or Modulating Electric Heat
33068	Signed Int (16-bit)	Timed Override Timer Is Active	Indicates whether or not the timed override timer is active	0 = Inactive 1 = Active	X	X	X	X	All Packaged RTU
33076	Signed Int (16-bit)	Diagnostic Present	Diagnostic Present	0 = Normal 1 = In Alarm	X	X	X	X	All Packaged RTU
33012	Signed Int (16-bit)	Changeover Input	Indicates the status of the (heat/cool) changeover input	0 = Heating 1 = Cooling	X	X			Discharge Air Temperature Control and Heat Present
33022	Signed Int (16-bit)	Condenser Fan Circuit 1 Relay 1 Status	Indicates the status of condenser fan circuit 1, relay 1	0 = Off 1 = On	X	X	X	X	Standard Ambient Condenser Control Present
33023	Signed Int (16-bit)	Condenser Fan Circuit 1 Relay 2 Status	Indicates the status of condenser fan circuit 1, relay 2	0 = Off 1 = On	X	X	X	X	All Packaged RTU
33024	Signed Int (16-bit)	Condenser Fan Circuit 1 Relay 3 Status	Indicates the status of condenser fan circuit 1, relay 3	0 = Off 1 = On	X	X	X	X	All Packaged RTU, 60-75T
33025	Signed Int (16-bit)	Condenser Fan Circuit 1 Relay 4 Status	Indicates the status of condenser fan circuit 1, relay 4	0 = Off 1 = On	X	X	X	X	All Packaged RTU, 90-130T
33026	Signed Int (16-bit)	Condenser Fan Circuit 2 Relay 1 Status	Indicates the status of condenser fan circuit 2, relay 1	0 = Off 1 = On	X	X	X	X	Standard Ambient Condenser Control Present
33027	Signed Int (16-bit)	Condenser Fan Circuit 2 Relay 2 Status	Indicates the status of condenser fan circuit 2, relay 2	0 = Off 1 = On	X	X	X	X	All Packaged RTU, 40-75T
33028	Signed Int (16-bit)	Condenser Fan Circuit 2 Relay 3 Status	Indicates the status of condenser fan circuit 2, relay 3	0 = Off 1 = On	X	X	X	X	All Packaged RTU, 60-75T
33029	Signed Int (16-bit)	Condenser Fan Circuit 2 Relay 4 Status	Indicates the status of condenser fan circuit 2, relay 4	0 = Off 1 = On	X	X	X	X	All Packaged RTU, 90-130T
33047	Signed Int (16-bit)	Emergency Stop	Indicates the status of the emergency stop function of the unit	0 = Auto 1 = Emergency Stop - Manual Reset Required	X	X	X	X	All Packaged RTU
33049	Signed Int (16-bit)	External Auto Stop Input Status	Indicates the status of the externally-wired auto/stop input	0 = Stop 1 = Auto	X	X	X	X	All Packaged RTU

Table 3. Binary input (continued)

Object Identifier	Data Type	Object Name	Description	Object States	VVDA ^(a)	CVDA ^(b)	VVZT ^(c)	CVZT ^(d)	When Exists
33065	Signed Int (16-bit)	Supply Fan Bypass Status	Indicates the status of the supply fan bypass from the variable frequency drive (VFD)	0 = Off 1 = On	X	X	X	X	Supply Fan VFD Bypass Present
33071	Signed Int (16-bit)	Ventilation Mode A Local	Indicates when the controller is actively in the Ventilation Override Mode A	0 = Inactive 1 = Active	X	X	X	X	Ventilation Override Present
33072	Signed Int (16-bit)	Ventilation Mode B Local	Indicates when the controller is actively in the Ventilation Override Mode B	0 = Inactive 1 = Active	X	X	X	X	Ventilation Override Present
33073	Signed Int (16-bit)	Ventilation Mode C Local	Indicates when the controller is actively in the Ventilation Override Mode C	0 = Inactive 1 = Active	X	X	X	X	Ventilation Override Present
33074	Signed Int (16-bit)	Ventilation Mode D Local	Indicates when the controller is actively in the Ventilation Override Mode D	0 = Inactive 1 = Active	X	X	X	X	Ventilation Override Present
33075	Signed Int (16-bit)	Ventilation Mode E Local	Indicates when the controller is actively in the Ventilation Override Mode E	0 = Inactive 1 = Active	X	X	X	X	Ventilation Override Present
33031	Signed Int (16-bit)	Diagnostic: Manual Reset Required	Indicates when a diagnostic exists that requires manual reset	0 = Normal 1 = In Alarm	X	X	X	X	All Packaged RTU
33046	Signed Int (16-bit)	Economizer Airside Status	Indicates the status of airside economizing. This value will be true when airside economizing is active/ enabled.	0 = Inactive 1 = Active	X	X	X	X	Economizer Present
33048	Signed Int (16-bit)	Exhaust Fan Output Status	Indicates the status of the exhaust fan output on the controller	0 = Off 1 = On	X	X	X	X	Relief/Exhaust Fan Present
33055	Signed Int (16-bit)	Heat Output 1 Status	Indicates the commanded state of heating output 1	0 = Off 1 = On	X	X	X	X	Heat Present
33056	Signed Int (16-bit)	Heat Output 2 Status	Indicates the commanded state of heating output 2	0 = Off 1 = On	X	X	X	X	Heat Present
33057	Signed Int (16-bit)	Heat Output 3 Status	Indicates the commanded state of heating output 3	0 = Off 1 = On	X	X	X	X	Heat Present
33058	Signed Int (16-bit)	Heat Output 4 Status	Indicates the commanded state of heating output 4	0 = Off 1 = On	X	X	X	X	Heat Present
33067	Signed Int (16-bit)	Supply Fan Output Status	Indicates the status of the supply fan output of the controller	0 = Off 1 = On	X	X	X	X	All Packaged RTU
33035	Signed Int (16-bit)	Diagnostic: Discharge Air High Temperature Detected	Indicates when a discharge air high temperature diagnostic is present	0 = No 1 = Yes	X	X	X	X	All Packaged RTU
33037	Signed Int (16-bit)	Diagnostic: Loss of Charge Lockout Ckt1	Indicates when a loss of charge lockout diagnostic exists for DX circuit 1	0 = No 1 = Yes	X	X	X	X	All Packaged RTU
33038	Signed Int (16-bit)	Diagnostic: Loss of Charge Lockout Ckt2	Indicates when a loss of charge lockout diagnostic exists for DX circuit 2	0 = No 1 = Yes	X	X	X	X	All Packaged RTU, 40-75T
33040	Signed Int (16-bit)	Diagnostic: Morning Warmup Mode Exceeded 120 Minutes	Indicates when the morning warmup mode has exceeded 120 consecutive minutes	0 = No 1 = Yes	X	X	X	X	Heat Present

Points List

Table 3. Binary input (continued)

Object Identifier	Data Type	Object Name	Description	Object States	VVDA ^(a)	CVDA ^(b)	VVZT ^(c)	CVZT ^(d)	When Exists
33041	Signed Int (16-bit)	Diagnostic: Pre Cool Mode Exceeded 120 Minutes	Indicates when the pre-cool mode has exceeded 120 consecutive minutes	0 = No 1 = Yes	X	X	X	X	All Packaged RTU
33043	Signed Int (16-bit)	Diagnostic: Return Air High Temperature Detected	Indicates when a return air high temperature diagnostic is present	0 = No 1 = Yes	X	X	X	X	Economizer with Comparative Enthalpy
33033	Signed Int (16-bit)	Diagnostic: Condensate Overflow Lockout	Indicates when a condensate overflow lockout diagnostic is present	0 = No 1 = Yes	X	X	X	X	Condensate Overflow Switch Present
33045	Signed Int (16-bit)	Diagnostic: High Condensate Level Detected	Indicates when a high condensate level is detected	0 = No 1 = Yes	X	X	X	X	Condensate Overflow Switch Present
33079	Signed Int (16-bit)	Supply Fan Speed Control Enabled	Supply fan speed is controlled via Supply Fan Speed Setpoint. If disabled/inactive, supply fan speed control is under local control.	0 = Inactive 1 = Active	X		X		Variable Volume Supply Fan Control
33080	Signed Int (16-bit)	Supply Fan Speed Limited	Supply fan speed is being increased or decreased due to a limit control action	0 = Not Limited 1 = Limited	X		X		Variable Volume Supply Fan Control
33081	Signed Int (16-bit)	Exhaust Fan Speed Control Enabled	Exhaust fan speed is controlled via Exhaust Fan Speed Setpoint. If disabled/ inactive, supply fan speed control is under local control.	0 = Inactive 1 = Active	X	X	X	X	Relief/Exhaust Fan Present
33082	Signed Int (16-bit)	Diagnostic: Shutdown Present	Unit is shut down due to diagnostics	0 = Normal 1 = In Alarm	X	X	X	X	All Packaged RTU
33083	Signed Int (16-bit)	Diagnostic: Local Manual Reset Required	Diagnostic Reset required [Local only]	0 = Normal 1 = In Alarm	X	X	X	X	All Packaged RTU
33087	Signed Int (16-bit)	Exhaust Fan Bypass Status	Indicates the status of the exhaust fan bypass from the variable frequency drive (VFD)	0 = Off 1 = On	X	X	X	X	Exhaust Fan VFD Bypass Present
33088	Signed Int (16-bit)	Return Fan Bypass Status	Indicates the status of the return fan bypass from the variable frequency drive (VFD)	0 = Off 1 = On	X	X	X	X	Return Fan VFD Bypass Present
33092	Signed Int (16-bit)	Heating Capacity Control Enabled	Status of heating capacity enabled	0 = Disabled 1 = Enabled	X	X	X	X	Energy Recovery Wheel
33093	Signed Int (16-bit)	Outdoor Air Damper Control Enabled	Status of outdoor air damper enabled	0 = Disabled 1 = Enabled	X	X	X	X	Economizer Present
33094	Signed Int (16-bit)	Return Fan Speed Control Enabled	Status of return fan speed enabled	0 = Disabled 1 = Enabled	X	X	X	X	Return Fan Present
33095	Signed Int (16-bit)	Cooling Capacity Control Enabled	Status of cooling capacity enabled	0 = Disabled 1 = Enabled	X	X	X	X	All Packaged RTU
33096	Signed Int (16-bit)	Final Filter Differential Press Setpoint Exceeded	Indicates when the Final Filter Diff Pressure Setpoint has been exceeded	0 = Inactive 1 = Active	X	X	X	X	All Packaged RTU
33097	Signed Int (16-bit)	Pre Evap Filter Differential Pressure Setpoint Exceeded	Indicates when the Pre Evap Filter Diff Pressure Setpoint has been exceeded	0 = Inactive 1 = Active	X	X	X	X	All Packaged RTU
33098	Signed Int (16-bit)	Energy Wheel Filter Differential Pressure Setpoint Exceeded	Indicates when the Energy Wheel Filter Diff Pressure Setpoint has been exceeded	0 = Inactive 1 = Active	X		X		Energy Recovery Wheel

^(a) VVDA - Variable Volume Discharge Air Temperature Control

^(b) CVDA - Constant Volume Discharge Air Temperature Control

Table 3. Binary input (continued)

- (c) VVZT - Variable Volume Zone Temperature Control
- (d) CVZT - Constant Volume Zone Temperature Control

Points List
Table 4. Binary value

Object Identifier	Data Type	Object Name	Description	Relinquish Default	Object States ^(a)	VVDA ^(b)	CVDA ^(c)	VVZT ^(d)	CVZT ^(e)	When Exists	Last One Wins ^(f)
43016	Signed Int (16-bit)	Heat Lockout Command	Normally used by the BAS to command the unit to prevent heating operation	0 Normal	0 = Normal 1 = Locked Out	X	X	X	X	Heat Present	
43022	Signed Int (16-bit)	Supply Fan Configuration Command	Normally used by the BAS to command the unit supply fan configuration as either cycling or continuous	1 Continuous	0 = Cycling 1 = Continuous			X	X	Zone Temperature Control Present	
43013	Signed Int (16-bit)	Dehumidification Enable Command	Normally used by the BAS to disable unit dehumidification	0 Disable	0 = Disable 1 = Auto	X	X	X	X	Hot Gas Reheat Present	X
43020	Signed Int (16-bit)	Reset Diagnostic	Normally used by the BAS to initiate a request to reset any controller diagnostics	0 Normal	0 = Normal 1 = Reset	X	X	X	X	All Packaged RTU	X
43012	Signed Int (16-bit)	Daytime Warmup Enable Command	Normally used by the BAS to enable daytime warmup	1 Enable	0 = Disable 1 = Enable	X	X			Discharge Air Temperature Control and Heat Present	X
43017	Signed Int (16-bit)	Morning Warmup Enable Command	Normally used by the BAS to enable morning warmup	1 Enable	0 = Disable 1 = Enable	X	X	X	X	Heat Present	X
43018	Signed Int (16-bit)	Occupancy Input BAS	Normally used by the BAS to provide the requested occupancy state to the unit	1 Unoccupied	0 = Occupied 1 = Unoccupied	X	X	X	X	All Packaged RTU	
43011	Signed Int (16-bit)	Cooling Lockout BAS	Normally used by the BAS as a command to (temporarily) prevent all mechanical cooling	0 Normal	0 = Normal 1 = Locked Out	X	X	X	X	All Packaged RTU	
43014	Signed Int (16-bit)	Demand Limit Request BAS	This command is normally provided by the BAS to demand limit the unit. The command is used in conjunction with Demand Limit Setpoint to determine the percentage the unit will be limited.	0 Not Limited	0 = Not Limiting 1 = Limited	X	X	X	X	All Packaged RTU	
43015	Signed Int (16-bit)	Energy Consumption Reset	Normally used by the BAS to reset the energy consumption accumulated total	0 Accumulating	0 = Accumulating 1 = Reset	X	X	X	X	Power Monitoring Present	X
43019	Signed Int (16-bit)	Pre Cool Enable Command	Normally used by the BAS to enable pre-cool	1 Enable	0 = Disable 1 = Enable	X	X	X	X	All Packaged RTU	X
43021	Signed Int (16-bit)	Supply Air Tempering Enable	Normally used by the BAS to enable the supply (discharge) air tempering feature of the unit	0 Disable	0 = Disable 1 = Enable	X	X			Modulating Gas Primary Heat Present	X
43023	Signed Int (16-bit)	Rapid Restart Enable	Enables/Disables rapid restart operation	0 Disable	0 = Disable 1 = Enable	X	X	X	X	Rapid Restart Control	X
43024	Signed Int (16-bit)	Rapid Restart Economizer Enable	Enables/Disables economizer evaluation during rapid restart operation	0 Disable	0 = Disable 1 = Enable	X	X	X	X	Rapid Restart Control	X
43025	Signed Int (16-bit)	Supply Fan Speed Setpoint Enable	Enables Supply Fan Speed Setpoint control	0 Disable	0 = Disable 1 = Enable	X		X		Variable Volume Supply Fan Control	
43026	Signed Int (16-bit)	Exhaust Fan Speed Setpoint Enable	Enables Exhaust Fan Speed Setpoint control	0 Disable	0 = Disable 1 = Enable	X	X	X	X	Relief/Exhaust Fan Present	
43027	Signed Int (16-bit)	Supply Fan Compensation	Enables the outdoor air damper position to compensate for changes in supply fan speed	0 Disable	0 = Disable 1 = Enable	X		X		Economizer Present	X
43028	Signed Int (16-bit)	Energy Consumption Reset Meter 2	Normally used by the BAS to reset the energy consumption accumulated total for second power meter	0 Accumulating	0 = Accumulating 1 = Reset	X	X	X	X	Dual Power Monitoring Present	X

Table 4. Binary value (continued)

Object Identifier	Data Type	Object Name	Description	Relinquish Default	Object States ^(a)	VVDA ^(b)	CVDA ^(c)	VVZT ^(d)	CVZT ^(e)	When Exists	Last One Wins ^(f)
43029	Signed Int (16-bit)	Heating Capacity Setpoint Enable External	Enables Heating Capacity Setpoint control	0 Disable	0 = Disable 1 = Enable	X	X	X	X	Energy Recovery Wheel	X
43030	Signed Int (16-bit)	Outdoor Air Damper Position Setpoint Enable External	Enables Outdoor Air Damper Position Setpoint control	0 Disable	0 = Disable 1 = Enable	X	X	X	X	Economizer Present	X
43031	Signed Int (16-bit)	Exhaust Fan Speed Setpoint Enable External	Enables Exhaust Fan Speed Setpoint control	0 Disable	0 = Disable 1 = Enable	X	X	X	X	Exhaust Fan Present	X
43032	Signed Int (16-bit)	Return Fan Speed Setpoint Enable External	Enables Return Fan Speed Setpoint control	0 Disable	0 = Disable 1 = Enable	X	X	X	X	Return Fan Present	X
43033	Signed Int (16-bit)	Supply Fan Speed Setpoint Enable External	Enables Supply Fan Speed Setpoint control	0 Disable	0 = Disable 1 = Enable	X	X	X	X	All Packaged RTU	X
43034	Signed Int (16-bit)	Cooling Capacity Setpoint Enable External	Enables Cooling Capacity Setpoint control	0 Disable	0 = Disable 1 = Enable	X	X	X	X	All Packaged RTU	X

^(a) Binary Values are signed 16-bit integers with 0=false, 1=true, -1=invalid.

^(b) VVDA - Variable Volume Discharge Air Temperature Control

^(c) CVDA - Constant Volume Discharge Air Temperature Control

^(d) VVZT - Variable Volume Zone Temperature Control

^(e) CVZT - Constant Volume Zone Temperature Control

^(f) Last written value is persisted; not subject to a priority array

Points List
Table 5. Multi-State input

Object Identifier	Data Type	Object Name	Description	Object States	VVDA ^(a)	CVDA ^(b)	VVZT ^(c)	CVZT ^(d)	When Exists
32018	Unsigned Int (16-bit)	Heat Cool Mode Status	Indicates the current heat cool mode of the controller	1 = Auto 2 = Heat 3 = Morning Warm-up 4 = Cool 5 = Night Purge 6 = Pre Cool 7 = Off 8 = Test 9 = Emergency Heat 10 = Fan Only 11 = Free Cool 12 = Ice-Making 13 = Max Heat 14 = Economizer 15 = Dehumidify 16 = Calibrate	X	X	X	X	All Packaged RTU
32026	Unsigned Int (16-bit)	Ventilation Override Status	Indicates which of the 5 preprogrammed ventilation override modes is operations, when applicable	1 = Inactive 2 = Mode A Active 3 = Mode B Active 4 = Mode C Active 5 = Mode D Active 6 = Mode E Active	X	X	X	X	Ventilation Override Present
32020	Unsigned Int (16-bit)	Occupancy Status	Indicates the active occupancy mode of the controller	1 = Occupied 2 = Unoccupied 3 = Occupied Bypass 4 = Occupied Standby 5 = Auto	X	X	X	X	All Packaged RTU
32013	Unsigned Int (16-bit)	Cooling Reset Type Status	Indicates the type of cooling reset used by the controller	1 = None 2 = Outdoor Air 3 = Zone 4 = Return Air	X	X			Discharge Air Temperature Control
32019	Unsigned Int (16-bit)	Heating Reset Type Status	Indicates the type of heating reset used, when applicable	1 = None 2 = Outdoor Air 3 = Zone	X	X			Discharge Air Temperature Control and Heat Present
32025	Unsigned Int (16-bit)	Trane Unit Type	Indicates the equipment type according to the manufacturer's classification	1 = 1 Heat/1 Cool 2 = Heat Pump 3 = Blower Coil 4 = Unit Ventilator 5 = Fan Coil 6 = Rooftop 7 = Air Handler 8 = Vertical Self Contained 9 = Unitary 10 = VAV Box 11 = Fan Coil	X	X	X	X	All Packaged RTU
32015	Unsigned Int (16-bit)	Economizer Type	Indicates the general description of the type of economizer system	1 = None 2 = 2 Position Ventilation 3 = Modulation Economizer 4 = 2 Position Ventilation/ Waterside Economizer 5 = Waterside Economizer 6 = Airside/ Waterside Economizer 7 = TRAQ Damper 8 = Airside Economizer and TRAQ Damper/ Sensor 9 = Waterside Economizer and TRAQ Damper/ Sensor 10 = Airside/ Waterside Economizer and TRAQ Damper/Sensor	X	X	X	X	All Packaged RTU
32012	Unsigned Int (16-bit)	Condenser Type	Indicates the general description of the equipment condenser system	1 = None 2 = Air Cooled Condenser 3 = Water Cooled Condenser 4 = Evaporative Condenser	X	X	X	X	All Packaged RTU

Table 5. Multi-State input (continued)

Object Identifier	Data Type	Object Name	Description	Object States	VVDA ^(a)	CVDA ^(b)	VVZT ^(c)	CVZT ^(d)	When Exists
32021	Unsigned Int (16-bit)	Refrigerant Type	Indicates the type of refrigerant used in the equipment	1 = R-11 2 = R-12 3 = R-22 4 = R-123 5 = R-134A 6 = R-407C 7 = R-410A 8 = R-113 9 = R-114 10 = R-500 11 = R-502 12 = R-404A 13 = R-513A 14 = R-1233zd (E) 15 = R-514A 16 = R-1234ze (E)	X	X	X	X	All Packaged RTU
32023	Unsigned Int (16-bit)	System Mode Switch Local	Indicates the status of the system mode switch connected to the controller	1 = Off 2 = Auto 3 = Cool 4 = Heat 5 = Emergency Heat			X	X	Zone Temperature Control
32011	Unsigned Int (16-bit)	Arbitration Method	The arbitration method is used to define the source of the data being provided to the controller. The source can be defined as DEFAULT (stored in the controller, such as setpoints and settings), LOCAL (for wired/wireless sensors), or FULL (for all remote sources, including BMS, custom programming, etc.).	1 = Full (Auto) 2 = Local 3 = Default	X	X	X	X	All Packaged RTU
32024	Unsigned Int (16-bit)	Timed Override Request Active	Indicates the status of the timed override request (see above)	1 = Idle 2 = On 3 = Cancel	X	X	X	X	All Packaged RTU
32016	Unsigned Int (16-bit)	Electrical Service Type	Indicates the electrical service type used for the unit	1 = A+N 2 = A+B 3 = A+B+N 4 = A+B+C 5 = A+B+C+N	X	X	X	X	Power Monitoring Present
32014	Unsigned Int (16-bit)	Economizer Decision Method	Normally provided by the BAS to determine the method of enabling airside economizing	1 = Absolute Temperature 2 = Relative Temperature 3 = Absolute Enthalpy 4 = Comparative Enthalpy	X	X	X	X	Economizer present
32027	Unsigned Int (16-bit)	Economizer System Status	Indicates the status of enabling economizing	1 = Disabled 2 = Enabled 3 = Not Present	X	X	X	X	Economizer present
32028	Unsigned Int (16-bit)	Model Information [GEN2]	Indicates the type of equipment.	27 = IPAK	X	X	X	X	All Packaged RTU
32029	Unsigned Int (16-bit)	Electrical Service Type Meter 2	Indicates the electrical service type used for the second power connection on the unit	1 = A+N 2 = A+B 3 = A+B+N 4 = A+B+C 5 = A+B+C+N	X	X	X	X	Dual Power Monitoring Present
32030	Unsigned Int (16-bit)	Emergency Override BAS - Active	Indicates the status of emergency override	1 = Normal 2 = Pressurize 3 = Depressurize 4 = Purge 5 = Shutdown 6 = Fire	X	X	X	X	All Packaged RTU

^(a) VVDA - Variable Volume Discharge Air Temperature Control

^(b) CVDA - Constant Volume Discharge Air Temperature Control



Points List

Table 5. Multi-State input (continued)

- (c) VVZT - Variable Volume Zone Temperature Control
- (d) CVZT - Constant Volume Zone Temperature Control

Table 6. Multi-State value

Object Identifier	Data Type	Object Name	Description	Object States	VVDA ^(a)	CVDA ^(b)	VVZT ^(c)	CVZT ^(d)	When Exists	Last One Wins ^(e)
42012	Unsigned Int (16-bit)	Emergency Override BAS	Normally used by the BAS to command the unit into an emergency mode of operation	1 = Normal 2 = Pressurize 3 = Depressurize 4 = Purge 5 = Shutdown 6 = Fire	X	X	X	X	All Packaged RTU	
42011	Unsigned Int (16-bit)	Economizer Airside Enable BAS	Normally provided by the BAS to enable airside economizing	1 = Disabled 2 = Enabled 3 = Auto	X	X	X	X	Economizer present	
42013	Unsigned Int (16-bit)	Heat Cool Mode Request	Normally provided by the BAS to command the unit into a heat/cool mode, including additional possible control modes	1 = Auto 2 = Heat 3 = Morning Warm-up 4 = Cool 5 = Night Purge 6 = Pre Cool 7 = Off 8 = Test 9 = Emergency Heat 10 = Fan Only 11 = Free Cool 12 = Ice-Making 13 = Max Heat 14 = Economizer 15 = Dehumidify 16 = Calibrate	X	X	X	X	All Packaged RTU	
42014	Unsigned Int (16-bit)	Occupancy Request	Normally used by the BAS to command the unit into an occupancy mode	1 = Occupied 2 = Unoccupied 3 = Occupied Bypass 4 = Occupied Standby 5 = Auto	X	X	X	X	All Packaged RTU	
42015	Unsigned Int (16-bit)	Timed Override Request	Normally used by the BAS to request a temporary timed override during unoccupied	1 = Idle 2 = On 3 = Cancel	X	X	X	X	All Packaged RTU	
42016	Unsigned Int (16-bit)	Dehumidification Method	Normally used by the BAS to select how the unit determines when to dehumidify.	1 = Relative Humidity 2 = Dew Point	X	X	X	X	Hot Gas Reheat Present	X

^(a) VVDA - Variable Volume Discharge Air Temperature Control

^(b) CVDA - Constant Volume Discharge Air Temperature Control

^(c) VVZT - Variable Volume Zone Temperature Control

^(d) CVZT - Constant Volume Zone Temperature Control

^(e) Last written value is persisted; not subject to a priority array

Appendix A. Symbio™ 800 Controller Layout

Figure 9. Symbio™ 800 controller display and LEDs

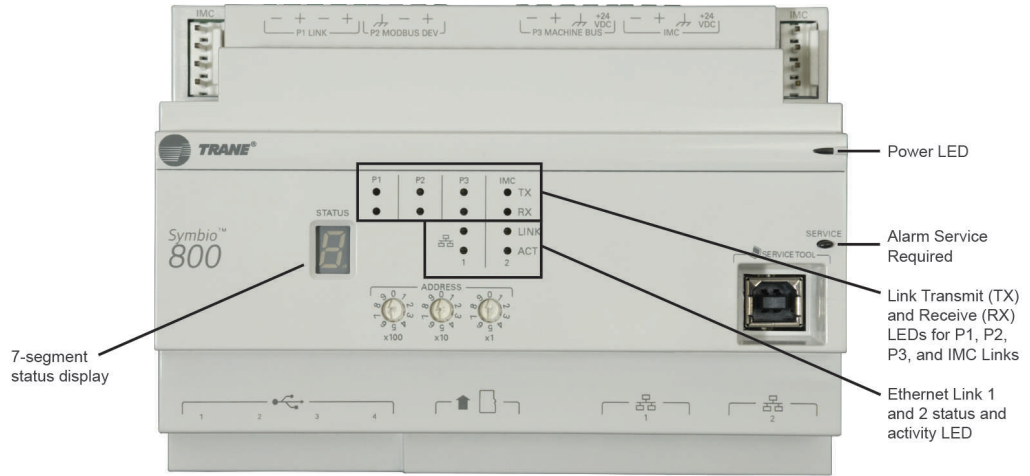

7-Segment status display

Table 7. Codes for 7-segment display segment

Code	Description
U0.	Waiting for USB drives to mount
U2.	Checking signature on the .scfw file
U3.	Checking software maintenance plan
U4.	Reformatting main filesystem (clearing database)
U5.	Beginning update
U12.	Searching for .scfw files on USB drive(s)
U51.	Updating main firmware
U54.	Updating FPGA image
U55.	Updating U-boot image
U57.	Updating recovery partition

Note: A code starting with an “F” indicates a failure, and requires Trane Service to resolve the issue.

P1 Link — BACnet MS/TP or Modbus RTU

- RS-485 daisy chain
- Used for connection to a manager controller

Figure 10. P2 Modbus device (factory installed Modbus server devices)

Note: The P2 link is intended for factory devices only and should not have any other devices added this link.

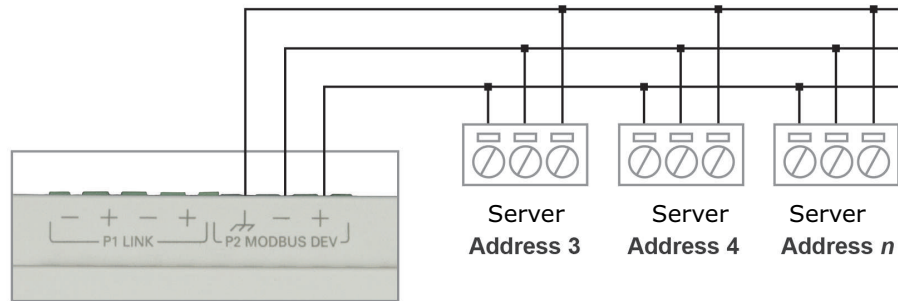

Figure 11. P3 machine bus (global bus — internal communication bus)

Note: The P3 link is intended for factory devices only and should not have any other devices added this link.

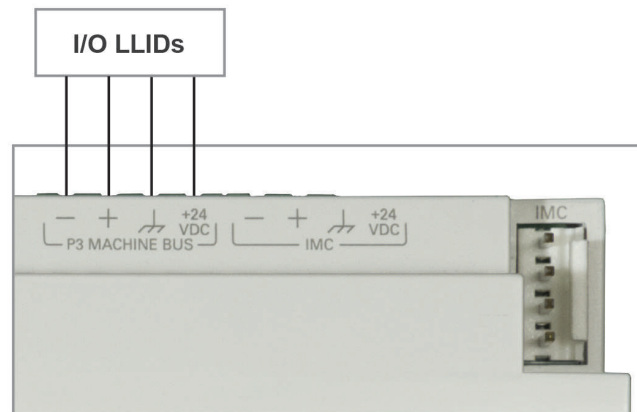
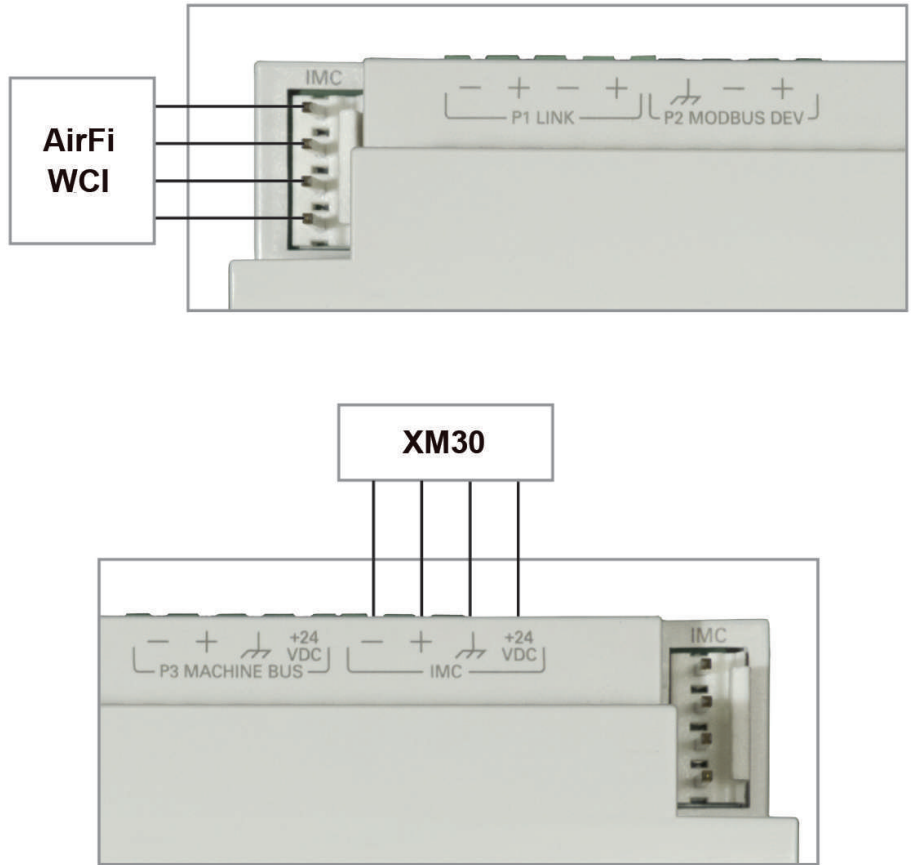
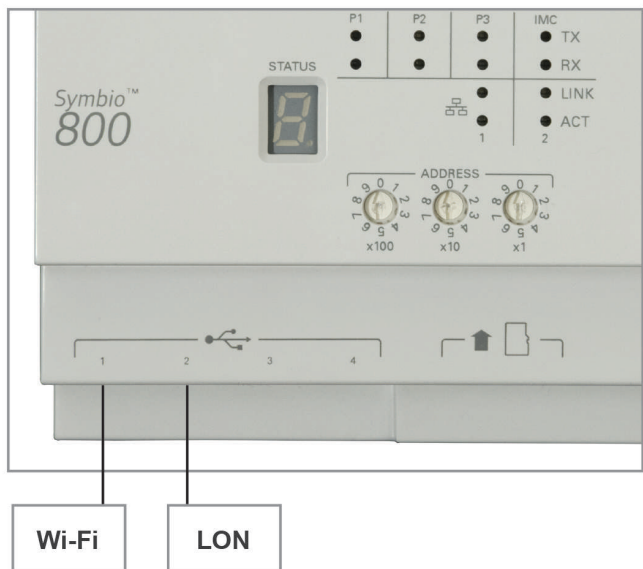

Figure 12. IMC link terminations for optional Air-Fi and expansion module (XM30)



For more information on Expansion Module wiring reference BAS-SVX46* – Expansion Module Installation Operation and Maintenance Manual.

Figure 13. (4) USB connectors



The controller automatically detects devices on any of the ports (not port specific). The controller ships with all ports enabled, but they can be disabled via the Web interface.

Note: *The USB ports are not to be used for any devices that are not Trane approved, such as cellular phones.*

Figure 14. Ethernet port 2

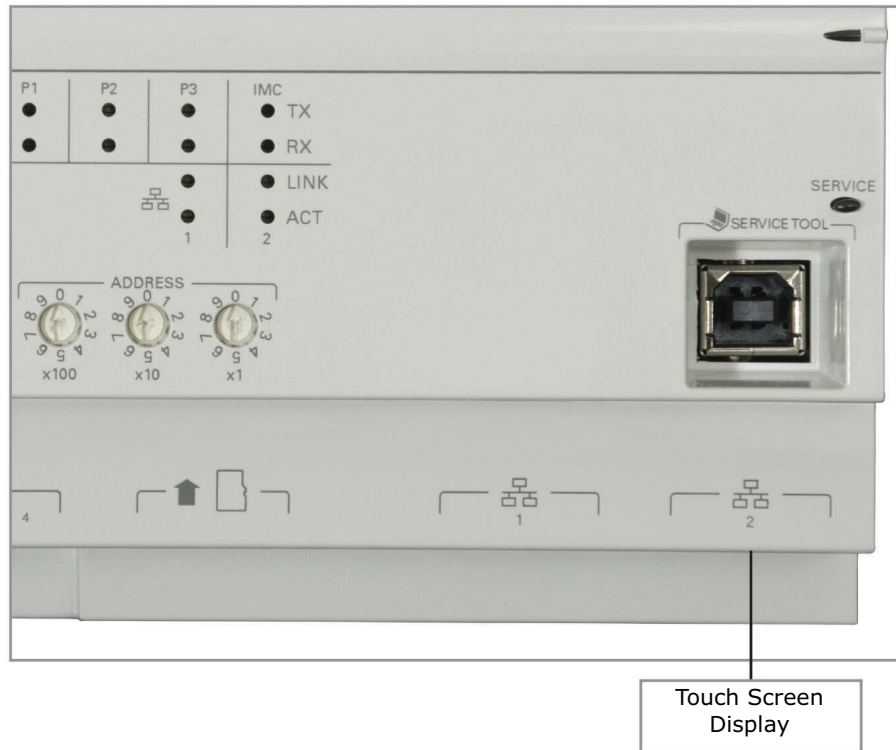

Note: *Ethernet Port 2 is for use with the Touch Screen display only. Communication to other devices is not supported.*

Trane - by Trane Technologies (NYSE: TT), a global innovator - creates comfortable, energy efficient indoor environments for commercial and residential applications. For more information, please visit trane.com or tranetechnologies.com.

Trane has a policy of continuous product and product data improvements and reserves the right to change design and specifications without notice. We are committed to using environmentally conscious print practices.

BAS-SVP041F-EN 11 Feb 2023
Supersedes BAS-SVP041E-EN (September 2022)

©2023 Trane