



Installation, Operation, and Maintenance

Optimus™ Water-Cooled Chillers Model RTHD



⚠ SAFETY WARNING

Only qualified personnel should install and service the equipment. The installation, starting up, and servicing of heating, ventilating, and air-conditioning equipment can be hazardous and requires specific knowledge and training. Improperly installed, adjusted or altered equipment by an unqualified person could result in death or serious injury. When working on the equipment, observe all precautions in the literature and on the tags, stickers, and labels that are attached to the equipment.



Introduction

Read this manual thoroughly before operating or servicing this unit.

Warnings, Cautions, and Notices

Safety advisories appear throughout this manual as required. Your personal safety and the proper operation of this machine depend upon the strict observance of these precautions.

The three types of advisories are defined as follows:

⚠ WARNING Indicates a potentially hazardous situation which, if not avoided, could result in death or serious injury.

⚠ CAUTION Indicates a potentially hazardous situation which, if not avoided, could result in minor or moderate injury. It could also be used to alert against unsafe practices.

NOTICE Indicates a situation that could result in equipment or property-damage only accidents.

Important Environmental Concerns

Scientific research has shown that certain man-made chemicals can affect the earth's naturally occurring stratospheric ozone layer when released to the atmosphere. In particular, several of the identified chemicals that may affect the ozone layer are refrigerants that contain Chlorine, Fluorine and Carbon (CFCs) and those containing Hydrogen, Chlorine, Fluorine and Carbon (HCFCs). Not all refrigerants containing these compounds have the same potential impact to the environment. Trane advocates the responsible handling of all refrigerants-including industry replacements for CFCs such as HCFCs and HFCs.

Important Responsible Refrigerant Practices

Trane believes that responsible refrigerant practices are important to the environment, our customers, and the air conditioning industry. All technicians who handle refrigerants must be certified. The Federal Clean Air Act (Section 608) sets forth the requirements for handling, reclaiming, recovering and recycling of certain refrigerants and the equipment that is used in these service procedures. In addition, some states or municipalities may have additional requirements that must also be adhered to for responsible management of refrigerants. Know the applicable laws and follow them.

⚠ WARNING

Proper Field Wiring and Grounding Required!

Failure to follow code could result in death or serious injury. All field wiring **MUST** be performed by qualified personnel. Improperly installed and grounded field wiring poses **FIRE** and **ELECTROCUTION** hazards. To avoid these hazards, you **MUST** follow requirements for field wiring installation and grounding as described in NEC and your local/state electrical codes.

⚠ WARNING

Personal Protective Equipment (PPE) Required!

Failure to wear proper PPE for the job being undertaken could result in death or serious injury. Technicians, in order to protect themselves from potential electrical, mechanical, and chemical hazards, **MUST** follow precautions in this manual and on the tags, stickers, and labels, as well as the instructions below:

- Before installing/servicing this unit, technicians **MUST** put on all PPE required for the work being undertaken (Examples; cut resistant gloves/sleeves, butyl gloves, safety glasses, hard hat/bump cap, fall protection, electrical PPE and arc flash clothing). **ALWAYS** refer to appropriate Material Safety Data Sheets (MSDS)/Safety Data Sheets (SDS) and OSHA guidelines for proper PPE.
- When working with or around hazardous chemicals, **ALWAYS** refer to the appropriate MSDS/SDS and OSHA/GHS (Global Harmonized System of Classification and Labelling of Chemicals) guidelines for information on allowable personal exposure levels, proper respiratory protection and handling instructions.
- If there is a risk of energized electrical contact, arc, or flash, technicians **MUST** put on all PPE in accordance with OSHA, NFPA 70E, or other country-specific requirements for arc flash protection, **PRIOR** to servicing the unit. **NEVER PERFORM ANY SWITCHING, DISCONNECTING, OR VOLTAGE TESTING WITHOUT PROPER ELECTRICAL PPE AND ARC FLASH CLOTHING. ENSURE ELECTRICAL METERS AND EQUIPMENT ARE PROPERLY RATED FOR INTENDED VOLTAGE.**

⚠ WARNING**Refrigerant under High Pressure!**

Failure to follow instructions below could result in an explosion which could result in death or serious injury or equipment damage. System contains oil and refrigerant under high pressure. Recover refrigerant to relieve pressure before opening the system. See unit nameplate for refrigerant type. Do not use non-approved refrigerants, refrigerant substitutes, or refrigerant additives.

Factory Warranty Information

Compliance with the following is required to preserve the factory warranty:

All Unit Installations

Startup **MUST** be performed by Trane, or an authorized agent of Trane, to **VALIDATE** this WARRANTY. Contractor must provide a two-week startup notification to Trane (or an agent of Trane specifically authorized to perform startup).

Additional Requirements for Units Requiring Disassembly

When a new fully assembled chiller is shipped and received from our Trane manufacturing location, and, for any reason, it requires disassembly or partial disassembly — which could include but is not limited to the evaporator, condenser, control panel, compressor/motor, or any other components originally attached to the fully assembled unit — compliance with the following is required to preserve the factory warranty:

- Trane, or an agent of Trane specifically authorized to perform startup and warranty of Trane® products, will perform or have direct onsite technical supervision of the disassembly and reassembly work.
- The installing contractor must notify Trane — or an agent of Trane specifically authorized to perform startup and warrant of Trane® products — two weeks in advance of the scheduled disassembly work to coordinate the disassembly and reassembly work.
- Startup must be performed by Trane or an agent of Trane specifically authorized to perform startup and warranty of Trane® products as noted above.

Trane, or an agent of Trane specifically authorized to perform startup and warranty of Trane® products, will provide qualified personnel and standard hand tools to perform the disassembly work at a location specified by the contractor. The contractor shall provide the rigging equipment such as chain falls, gantries, cranes, forklifts, etc. necessary for the disassembly and reassembly work

and the required qualified personnel to operate the necessary rigging equipment.

Copyright

This document and the information in it are the property of Trane, and may not be used or reproduced in whole or in part without written permission. Trane reserves the right to revise this publication at any time, and to make changes to its content without obligation to notify any person of such revision or change.

Trademarks

All trademarks referenced in this document are the trademarks of their respective owners.

Revision History

- Added 575V selection for units with optional AFD.
- Incorporated E3G3G3 configuration.
- Updated TD7 information in controls chapter.



Table of Contents

Model Number	6	Fused-disconnect switches or circuit breakers.	40
Unit Nameplate	6	Module Connections for Interconnecting Wiring	43
Compressor Nameplate	6	AFD Drive (Optional)	46
Model Number Descriptions	7	AFD Drive Installation	46
Unit Model Number	7	AFD Drive Programming	47
Compressor Model Number	8	Communications Interface	49
General Information	9	LonTalk Interface (LCI-C)	49
Unit Description	9	BACnet Interface (BCI-C)	49
Pre-Installation	14	Modbus Remote Terminal Unit Interface	49
Inspection	14	Operating Principles	50
Inspection Checklist	14	General	50
Loose Parts Inventory	14	Refrigeration Cycle	50
Storage	14	Refrigeration Circuits	50
Installation Requirements	15	Compressor and Motor	50
Dimensions and Weights	16	Evaporator and Condenser	50
Unit Dimensions	16	Oil Management	51
Unit Weights	16	Unit-Mounted Starter	51
Service Clearances	18	Controls	52
Installation Mechanical	19	UC800 Specifications	52
Location Requirements	19	Wiring and Port Descriptions	52
Sound Considerations	19	Communication Interfaces	53
Foundation	19	Rotary Switches	53
Clearances	19	LED Description and Operation	53
Ventilation	19	Tracer AdaptiView™ TD7 Display	53
Water Drainage	19	Operator Interface	53
Access Restrictions	19	Home Screen	54
Rigging	19	Viewing Chiller Operating Modes	54
Lifting Procedure	23	Alarms	56
Unit Leveling	26	Reports	57
Isolation Pads	26	Equipment Settings	59
Water Piping	31	Service Settings	61
Freeze Protection	37	Display Settings	61
Installation Electrical	38	Viewing the Settings Screen	61
General Recommendations	38	Cleaning the Display	63
Electrical Data	38	Security Settings	63
Standard Units with Wye-Delta Starter	38	Disabling/Enabling Security	63
Units with AFD Option	39	Tracer® TU	65
Installer-Supplied Components	39		

Pre-Start	66	Starter Diagnostics	83
Start-Up and Shutdown	67	Main Processor Diagnostics	86
Unit Start-Up	67	Communication Diagnostics	91
Temporary Shutdown And Restart	67	Operator Display Diagnostics and Messages	93
Extended Unit Shutdown	67	Wiring	94
Seasonal Unit Start-Up Procedure	67	Log and Check Sheets	95
Sequence of Operation	68		
Software Operation Overview	68		
Timelines	68		
Power Up	69		
Power Up to Starting	70		
Stopped to Starting	71		
Starting Wye-Delta	71		
Starting AFD	72		
Running	72		
Satisfied Setpoint	73		
Normal Shutdown to Stopped or Run Inhibit	74		
Immediate Shutdown to Stopped or Run Inhibit	75		
Momentary Power Loss	75		
Ice Making (Running to Ice Making to Running)	76		
Ice Making (Auto to Ice Making to Ice Making Complete)	76		
No Load Start	77		
Limit Conditions	77		
Maintenance	78		
Recommended Maintenance	78		
Weekly	78		
Monthly	78		
Annual	78		
Scheduling Other Maintenance	78		
Refrigerant and Oil Charge Management	78		
Maintenance Procedures	79		
Cleaning the Condenser	79		
Cleaning the Evaporator	80		
Oil Sump Level Check	81		
Optional AFD Periodic Maintenance and Inspection ..	82		
Diagnostics	83		



Model Number

Nameplates

The Optimus™ unit nameplates are applied to the exterior of the Control Panel. A compressor nameplate is located on the compressor. When the unit arrives, compare all nameplate data with ordering, submittal, and shipping information.

Unit Nameplate

See [Figure 1](#) for a typical unit nameplate. The unit nameplate provides the following information:

- Unit model and size description.
- Unit serial number.
- Identifies unit electrical requirements.
- Lists correct operating charges of R-134a and refrigerant oil.
- Lists unit test pressures.
- Identifies installation, operation and maintenance and service data literature.
- Lists drawing numbers for unit wiring diagrams.

Model Number Coding System

The model numbers for the unit and the compressor are composed of numbers and letters that represent features of the equipment. Shown in the following table is a sample

of typical unit model number and the coding system for each.

Each position, or group of positions, in the model number is used to represent a feature. For example, in the first table, position 08 of the unit model number, Unit Voltage, contains the letter "F". An F in this position means that the unit voltage is 460/60/3.

Unit Model Number. An example of a typical unit model number (M/N) is:

RTHD UB1F XG0U AB1A 2LAL B1A2 LALA VXQX EXAA
 AXY1 76DC XT52 XXXX XXH

Model number digits are selected and assigned in accordance with the definitions as listed in "[Unit Model Number](#)," p. 7.

Compressor Nameplate

The compressor nameplate provides the following information:

- Compressor model number. See "[Compressor Model Number](#)," p. 8.
- Compressor electrical characteristics.
- Utilization range.
- Recommended refrigerant.

Figure 1. Typical unit nameplate



Model Number Descriptions

Unit Model Number

Digits 1 - 4 – Chiller Model

RTHD= Water-Cooled Optimus™ Chiller

Digit 5 – Manufacturing Location

U = Water Chiller Business Unit, Pueblo, CO USA

Digits 6, 7 – Compressor Frame

B1 = B1 Compressor
B2 = B2 Compressor
C1 = C1 Compressor
C2 = C2 Compressor
D1 = D1 Compressor
D2 = D2 Compressor
D3 = D3 Compressor (50 hz only)
E3 = E3 Compressor (50 hz only)

Digits 8 – Unit Power Supply

A = 200V/60Hz/3Ph power
C = 230V/60Hz/3Ph power
D = 380V/60Hz/3Ph power
F = 460V/60Hz/3Ph power
H = 575V/60Hz/3Ph power
R = 380V/50Hz/3Ph power
T = 400V/50Hz/3Ph power
U = 415V/50Hz/3Ph power

Digit 9 – Specials

X = No Specials

Historical information:

C = Specials denoted elsewhere

S = Specials not denoted elsewhere

Digit 10, 11 – Design Sequence

** = Factory assigned

Digit 12 – Agency Listing

X = No Agency Listing

U = UL Listed to US and Canadian Safety Standard

A = IBC Seismically Rated

B = UL/Canadian and IBC

C = OSHPD Seismically Rated

D = UL/Canadian and OSHPD

Historical information:

3 = CCC - Chinese Compulsory Code

Note: Digit 12 selections A, B, C & D are special order only.

Digit 13 – Pressure Vessel Code

A = ASME Pressure Vessel Code

C = Canadian Code

D = Australian Code

L = Chinese Code-Imported Pressure Vessel

Historical information:

S = Special

Digits 14,15 – Evaporator

B1 = B1 Evaporator

B2 = B2 Evaporator

C1 = C1 Evaporator

C2 = C2 Evaporator

D1 = D1 Evaporator

D2 = D2 Evaporator

D3 = D3 Evaporator

D4 = D4 Evaporator

D5 = D5 Evaporator

D6 = D6 Evaporator

E1 = E1 Evaporator

F1 = F1 Evaporator

F2 = F2 Evaporator

G1 = G1 Evaporator

G2 = G2 Evaporator

G3 = G3 Evaporator

Digit 16 – Evaporator Tube Type

A = Enhanced fin copper (all fluids)

W = Enhanced fin copper (water only)

Digit 17 – Evaporator Water Pass Configuration

2 = 2 Pass

3 = 3 Pass

4 = 4 Pass

Digit 18 – Evaporator Water Connection

L = Left Hand

R = Right Hand

Digit 19 – Evaporator Connection Type

A = Standard Grooved Pipe

Historical information:

S = Special

Digit 20 – Evaporator Water Side Pressure

L = 150 psi (10.5 bar)

H = 300 psi (21 bar)

Digit 21, 22 – Condenser

B1 = B1 Condenser

B2 = B2 Condenser

D1 = D1 Condenser

D2 = D2 Condenser

E1 = E1 Condenser

E2 = E2 Condenser

E3 = E3 Condenser

E4 = E4 Condenser

E5 = E5 Condenser

F1 = F1 Condenser

F2 = F2 Condenser

F3 = F3 Condenser

G1 = G1 Condenser

G2 = G2 Condenser

G3 = G3 Condenser

Digit 23 – Condenser Tube Type

A = Enhanced Fin Copper - 0.028"

B = Smooth Bore Copper

C = Smooth Bore CuNi

D = Enhanced Fin Copper - 0.025"

Digit 24 – Condenser Water Passes

2 = 2 Pass

Digit 25 – Condenser Water Connection

L = Left Hand

R = Right Hand

Digit 26 – Condenser Connection Type

A = Standard Grooved Pipe

C = Marine

S = Special

Digit 27 – Condenser Waterside Pressure

L = 150 psi (10.5 bar)

H = 300 psi (21 bar)

Digit 28 – Condenser Leaving Water Temperature

A = Standard

Digit 29 – Refrigerant Isolation Valves

X = No Refrigerant Isolation Valves

V = With Refrigerant Isolation Valves

Digit 30 – Oil Cooler

X = Without Oil Cooler

C = With Oil Cooler

Digit 31 – Thermal Insulation

X = No Insulation

Q = Factory Installed Insulation

Digit 32 – Acoustic Insulation

X = No Insulation

Historical information:

A = Standard Attenuator

Digit 33 – Label and Literature Language

C = Spanish

E = English

F = French

Digit 34 – Safety Devices

X = Standard

Digit 35 – Factory Charge

A = Factory Refrigerant Charge (R-134a)

B = Factory Nitrogen Charge

Digit 36 – Shipping Package

A = No Skid (Standard)

B = Shrink Wrap

C = Skid

D = Skid + Shrink Wrap

Historical information:

J = Special



Model Number Descriptions

Digit 37 – Flow Switch

- X = No Flow Switch
- A = Evaporator (NEMA 1)
- B = Evaporator and Condenser (NEMA 1)
- C = Evaporator (NEMA 4)
- D = Evaporator and Condenser (NEMA 4)

Digit 38 – Factory Test

- X = Standard Test
- C = Witness Test
- D = Performance Test

Digit 39 – Starter Type

- Y = Wye-Delta Closed Transition Starter
- V = Premium AFD

Historical information:

- A = Solid State Starter

Digits 40 - 42 – Design RLA (for starter)

*** = Selection Assigned

Digit 43 – Power Line Connection Type

- A = Terminal Block
- B = Mechanical Disconnect Switch
- D = Circuit Breaker
- F = High Interrupt Circuit Breaker

Historical information:

- H = Ground Fault Circuit Breaker
- J = Ground Fault High Interrupt Circuit Breaker

Digit 44 – Max RLA (Starter)

- C = 277 max RLA (Fixed Speed)
- E = 364 max RLA (Fixed Speed)
- G = 126 max RLA (Drive and Panel)
- H = 150 max RLA (Drive and Panel)
- J = 185 max RLA (Drive and Panel)
- K = 234 max RLA (Drive and Panel)
- L = 279 max RLA (Drive and Panel)
- M = 316 max RLA (Drive and Panel)
- N = 366 max RLA (Drive and Panel)
- Q = 397 max RLA (Fixed Speed)
- R = 476 max RLA (Fixed Speed)
- T = 598 max RLA (Fixed Speed)
- U = 779 max RLA (Fixed Speed)
- V = 197 max RLA (Drive and Panel)
- W = 241 max RLA (Drive and Panel)
- X = 292 max RLA (Drive and Panel)
- Y = 367 max RLA (Drive and Panel)
- Z = 446 max RLA (Drive and Panel)
- 1 = 549 max RLA (Drive and Panel)
- 2 = 176 max RLA (Drive and Panel)
- 3 = 223 max RLA (Drive and Panel)
- 4 = 280 max RLA (Drive and Panel)
- 5 = 335 max RLA (Drive and Panel)
- 6 = 411 max RLA (Drive and Panel)
- 7 = 455 max RLA (Drive and Panel)

Historical information - Enclosure Type:

- F = NEMA 1 - MRLA207
- G = NEMA 1 - MRLA277
- H = NEMA 1 - MRLA300
- J = NEMA 1 - MRLA364
- K = NEMA 1 - MRLA397
- L = NEMA 1 - MRLA476
- M = NEMA 1 - MRLA500
- N = NEMA 1 - MRLA598
- P = NEMA 1 - MRLA779

Digit 45 – Under/Over Voltage Protection

- X = None
- U = With Under/Over Voltage Protection

Digit 46 – Operator Interface

- T = Tracer AdaptiView™ TD7 Display

Historical information:

- A = DynaView™ - English
- B = DynaView - French
- C = DynaView - Italian
- D = DynaView - Spanish
- E = DynaView - German
- F = DynaView - Dutch
- G = DynaView - Chinese (traditional)
- H = DynaView - Chinese (simple)
- J = DynaView - Japanese
- K = DynaView - Portugese (Brazil)
- L = DynaView - Korean
- M = DynaView - Thai

Digit 47 – Digital Communication Interface

- X = None
- 5 = LCI-C (LonTalk®) Interface
- 7 = BACnet®
- 8 = Modbus™ Interface

Historical information:

- 4 = Tracer® Comm 4 Interface
- 6 = BACnet® for CH530 Controls

Digit 48 – External Water & Current-Limit Setpoint

- X = None
- 2 = 2–10 Vdc input
- 4 = 4–20 mA input

Digit 49 – External Base Loading

- X = None
- 2 = 2–10 Vdc input
- 4 = 4–20 mA input

Digit 50 – Ice Making

- X = None
- A = Ice Making with Relay
- B = Ice Making without Relay

Digit 51 – Programmable Relays

- X = None
- R = With Programmable Relays

Digit 52 – Chilled Water Reset

- X = Chilled Water Reset - Return Water
- T = Chilled Water Reset - Outdoor Air Temperature

Digit 53 – Control Outputs

- X = None
- D = Chiller Differential Pressure & Percent RLA
- P = Condenser Pressure (% HPC) & Percent RLA
- V = Condenser Regulating Valve Control & Percent RLA

Digits 54 – Refrigerant Monitor Input

- X = None
- A = 100 ppm / 4-20 mA
- B = 1000 ppm / 4-20 mA
- C = 100 ppm / 2-10 Vdc
- D = 1000 ppm / 2-10 Vdc

Digit 55 – Condenser Leaving Hot Water Temp Control

- X = None
- H = Hot Water Temp Control

Digits 56 - 58 – AFD Output Amps

- 000 = Not applicable (wye-delta starter)
- *** = Selection Assigned

Compressor Model Number

Digits 1 - 4 – Compressor Model

- CHHC= Positive displacement, helical rotary (twin screw) hermetic compressor

Digit 5 – Design Control

- * = Factory Assigned

Digit 6 – Frame Size

- B = B Frame
- C = C Frame
- D = D Frame
- E = E Frame

Digit 7 – Capacity

- 1 = Smaller capacity (minor)
- 2 = Larger capacity (major)
- 3 = Special 50 Hz

Digit 8 – Motor Voltage

- A = 200V/60Hz/3Ph
- C = 230V/60Hz/3Ph
- D = 380V/60Hz/3Ph
- F = 400/460V- 50/60Hz - 3Ph used for 380V/50Hz/3Ph
- H = 575V/60Hz/3Ph
- M = 690V/50Hz/3Ph
- B = 525V/50Hz/3Ph
- G = 500V/50Hz/3Ph
- S = Special voltage

Digit 9 – Design Specials

- 0 = No specials
- C = All specials denoted by digits elsewhere
- S = Uncategorized special not denoted by other digits

Digits 10 - 11 – Design Sequence

- ** = Factory assigned

General Information

Unit Description

The RTHD units are single compressor, helical-rotary type, water-cooled liquid chillers designed for installation indoors. Each unit is a completely assembled, hermetic package that is factory-piped, wired, leak-tested, dehydrated, charged (optional), and tested for proper control operation before shipment.

Figure 2 through Figure 4 show typical Optimus™ units and their components. Water inlet and outlet openings are covered before shipment. The oil tank is factory charged with the proper amount of refrigeration oil. The unit can be factory charged with refrigerant.

Figure 2. Component location – Optimus™ wye-delta starter (front view)

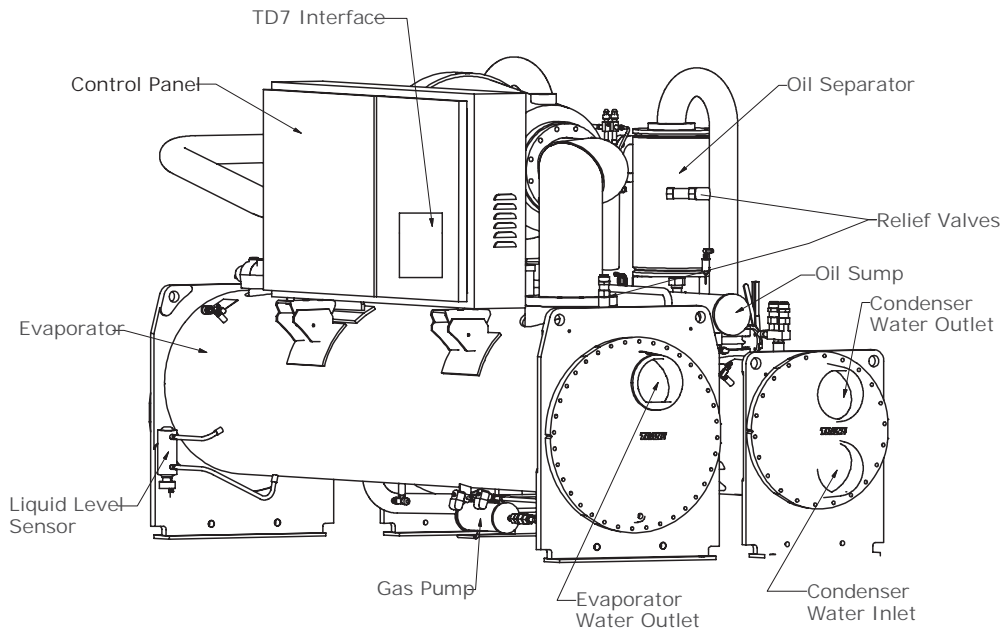
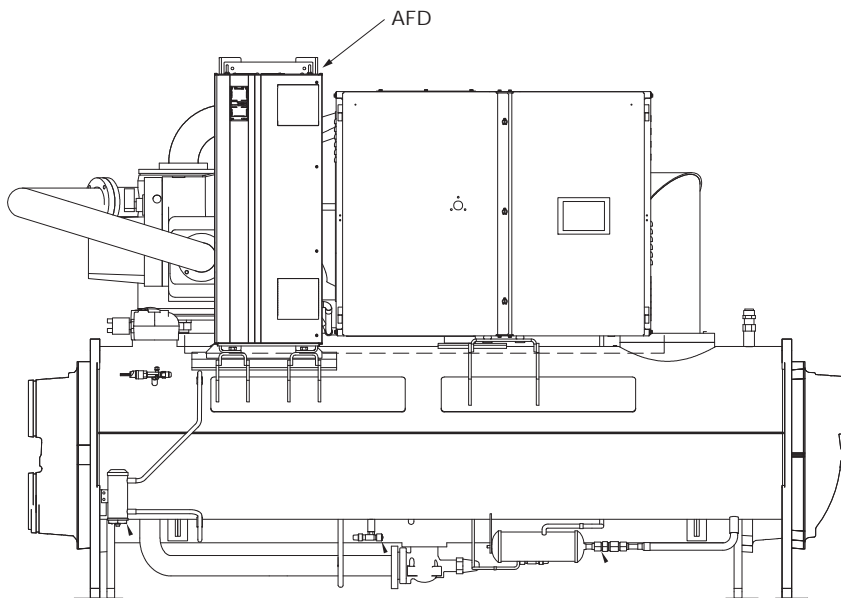
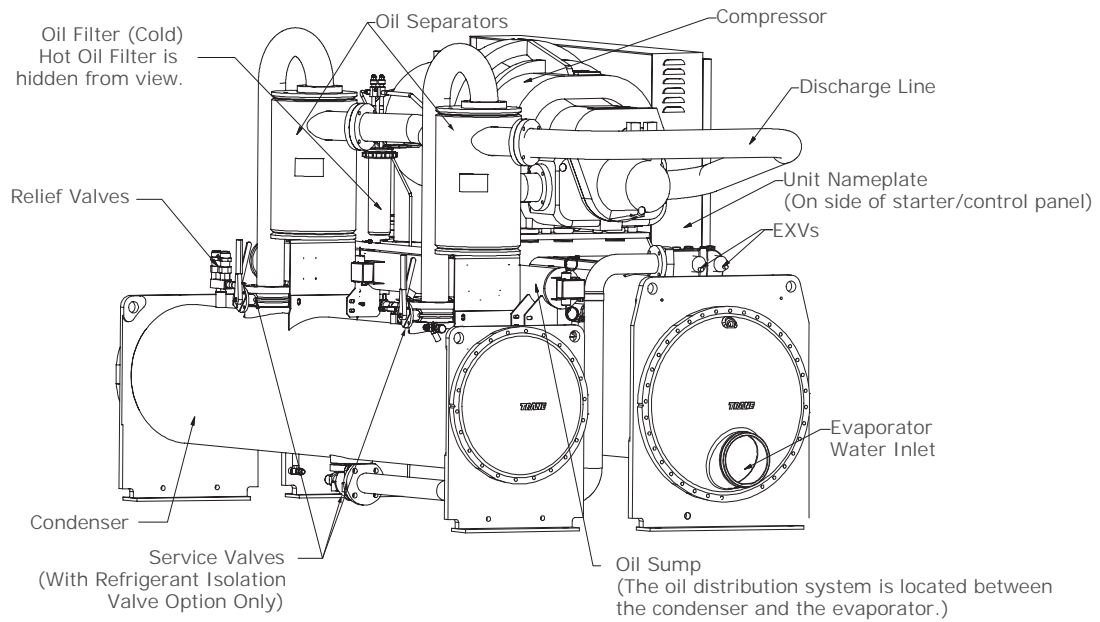

Figure 3. Component location – Optimus™ with AFD (front view)(a)



(a) Component locations shown in Figure 2 are the same for units with optional AFD.

Figure 4. Component location – Optimus (back view)^(a)

(a) Optional AFD is not shown. See [Figure 3, p. 9](#) for location of optional AFD.

Table 1. General data

Unit Configuration ^(a)		B1B1B1	B1C1D1	B2B2B2	B2C2D2	C1D5E4	C1D6E5	C1E1F1	C2D3E3
GENERAL									
Refrigerant Type		HFC-134a							
Refrigerant Charge	lb	410	490	410	490	490	490	525	490
	kg	186	222	186	222	222	222	238	222
Oil Type (wye-delta)		OIL48							
Oil Charge ^(b) (wye-delta)	gal	4.5	4.5	4.5	4.5	6	6	10	6
	L	17	17	17	17	23	23	38	23
Oil Type (AFD)		OIL315							
Oil Charge (AFD)	gal	7.5	7.5	7.5	7.5	10	10	11	10
	L	28.5	28.5	28.5	28.5	38	38	42	38
EVAPORATOR									
Water Storage	gal	41	55	45	58	52	45	82	78
	L	155	208	170	220	197	170	310	295
Connection size	in	8	8	8	8	8	8	8	8
	mm	200	200	200	200	200	200	200	200
Min Flow - Water	gpm	253	320	288	347	351	293	450	486
	l/s	16	18	22	22	21	18	28	31
2-pass Min Flow - Freeze Inhibitor	gpm	303	346	346	375	422	352	487	584
	l/s	19	22	22	24	27	22	31	37
Maximum Flow	gpm	1104	1412	1266	1531	1542	1287	1980	2131
	l/s	70	89	80	97	97	81	125	134
Connection size	in	6	6	6	6	8	8	8	8
	mm	150	150	150	150	200	200	200	200
Min Flow - Water	gpm	168	213	192	232	234	196	300	324
	l/s	11	13	12	15	15	12	19	20
3-pass Min Flow - Freeze Inhibitor	gpm	200	254	233	276	281	233	357	389
	l/s	13	16	15	17	18	15	23	25
Maximum Flow	gpm	736	941	844	1022	1028	860	1320	1417
	l/s	46	59	53	65	65	54	83	89
CONDENSER (all are 2-pass)									
Connection size	in	6	6	6	6	8	8	8	8
	mm	150	150	150	150	200	200	200	200
Water Storage	gal	28	31	29	34	32	29	60	47
	L	106	117	110	129	121	110	226	178
Min Flow - Water	gpm	193	193	212	212	245	206	375	325
	l/s	12	12	13	13	15	13	24	21
Min Flow - Freeze Inhibitor	gpm	230	230	255	255	295	250	450	390
	l/s	15	15	16	16	19	16	28	25
Max Flow	gpm	850	850	935	935	1080	910	1650	1420
	l/s	54	54	59	59	68	57	104	90

(a) Unit configuration digits 1, 2 - compressor code (also shown in unit model number digits 6, 7); digits 3, 4 - evaporator code (unit model number digits 14, 15); digits 5, 6 - condenser code (unit model number digits 21, 22).
 (b) If oil cooler is installed, add 0.3 gal (1L) to oil charge value given for B compressor family units. Add 1.0 gal (4L) for all other units.



General Information

Table 2. General data

Unit Configuration ^(a)		C2D4E4	C2F2F3	D1D1E1	D1F1F2	D1G1G1	D1G2G2	D2D2E2	D2F2F3
GENERAL									
Refrigerant Type		HFC-134a							
Refrigerant Charge	lb	490	625	475	625	700	700	475	625
	kg	222	284	216	284	318	318	216	284
Oil Type (wye-delta)		OIL48							
Oil Charge ^(b) (wye-delta)	gal	6	10	6	10	11	11	6	10
	L	23	38	23	38	42	42	23	38
Oil Type (AFD)		OIL315							
Oil Charge (AFD)	gal	10	12	9.5	11	13.5	13.5	9.5	11
	L	38	45.5	36	42	51	51	36	42
EVAPORATOR									
Water Storage	gal	52	107	69	102	136	144	74	107
	L	197	405	261	386	515	545	280	405
Connection size	in	8	10	8	10	-	-	8	10
	mm	200	250	200	250	-	-	200	250
Min Flow - Water	gpm	351	604	415	563	-	-	450	604
	l/s	21	38	26	36	-	-	28	38
Min Flow - Freeze Inhibitor	gpm	422	725	498	676	-	-	541	725
	l/s	27	46	31	43	-	-	34	46
Maximum Flow	gpm	1542	2667	1812	2478	-	-	1980	2667
	l/s	97	168	114	156	-	-	125	168
Connection size	in	8	8	8	8	10	10	8	8
	mm	200	200	200	200	250	250	200	200
Min Flow - Water	gpm	234	404	275	376	505	550	300	404
	l/s	15	25	17	24	35	35	19	25
Min Flow - Freeze Inhibitor	gpm	281	487	330	454	606	660	357	487
	l/s	18	31	21	29	38	42	23	31
Maximum Flow	gpm	1028	1780	1206	1655	2218	2413	1320	1780
	l/s	65	112	76	104	140	152	83	112
Connection size	in	-	-	-	-	8	8	-	-
	mm	-	-	-	-	200	200	-	-
Min Flow - Water	gpm	-	-	-	-	379	411	-	-
	l/s	-	-	-	-	24	26	-	-
Min Flow - Freeze Inhibitor	gpm	-	-	-	-	454	492	-	-
	l/s	-	-	-	-	29	31	-	-
Maximum Flow	gpm	-	-	-	-	1666	1807	-	-
	l/s	-	-	-	-	105	114	-	-
CONDENSER (all are 2-pass)									
Connection size	in	8	8	8	8	8	8	8	8
	mm	200	200	200	200	200	200	200	200
Water Storage	gal	32	61	44	57	79	91	47	61
	L	121	231	166	216	299	344	178	231
Min Flow - Water	gpm	245	355	291	355	444	535	316	385
	l/s	15	22	18	22	28	34	20	24
Min Flow - Freeze Inhibitor	gpm	295	460	350	430	530	650	380	460
	l/s	19	29	22	27	33	41	24	29
Max Flow	gpm	1080	1700	1280	1560	1960	2360	1390	1700
	l/s	68	107	81	98	124	149	88	107

(a) Unit configuration digits 1, 2 - compressor code (also shown in unit model number digits 6, 7); digits 3, 4 - evaporator code (unit model number digits 14, 15); digits 5, 6 - condenser code (unit model number digits 21, 22).

(b) If oil cooler is installed, add 0.3 gal (1L) to oil charge value given for B compressor family units. Add 1.0 gal (4L) for all other units.



General Information

Table 3. General data

Unit Configuration ^(a)		D2G2G1	D2G3G3	D3D2E2	D3F2F3	D3G2G1	E3D2E2	E3F2F3	E3G2G1	E3G3G3
GENERAL										
Refrigerant Type		HFC-134a								
Refrigerant Charge	lb	700	700	475	625	700	475	625	700	700
	kg	318	318	216	284	318	216	284	318	318
Oil Type (wye-delta)		OIL48								
Oil Charge ^(b) (wye-delta)	gal	11	11	6	10	11	6	10	11	11
	L	42	42	23	38	42	23	38	42	42
Oil Type (AFD)		OIL315								
Oil Charge (AFD)	gal	13.5	13.5	9.5	11	13.5	9.5	11	13.5	13.5
	L	51	51	36	42	51	36	42	51	51
EVAPORATOR										
Water Storage	gal	144	159	74	107	144	74	107	144	159
	L	545	602	280	405	545	280	405	545	602
2-pass Connection size	in	-	-	8	10	-	8	10	-	-
	mm	-	-	200	250	-	200	250	-	-
Min Flow - Water	gpm	-	-	450	604	-	450	604	-	-
	l/s	-	-	28	38	-	28	38	-	-
Min Flow - Freeze Inhibitor	gpm	-	-	541	725	-	541	725	-	-
	l/s	-	-	34	46	-	34	46	-	-
Maximum Flow	gpm	-	-	1980	2667	-	1980	2667	-	-
	l/s	-	-	125	168	-	125	168	-	-
3-pass Connection size	in	10	10	8	8	10	8	8	10	10
	mm	250	250	200	200	250	200	200	250	250
Min Flow - Water	gpm	550	622	300	404	550	300	404	550	622
	l/s	35	39	19	25	35	19	25	35	39
Min Flow - Freeze Inhibitor	gpm	660	747	357	487	660	357	487	660	747
	l/s	42	47	23	31	42	23	31	42	47
Maximum Flow	gpm	2413	2732	1320	1780	2413	1320	1780	2413	2732
	l/s	152	172	83	112	152	83	112	152	172
4-pass Connection size	in	8	8	-	-	8	-	-	8	8
	mm	200	200	-	-	200	-	-	200	200
Min Flow - Water	gpm	411	466	-	-	411	-	-	411	466
	l/s	26	29	-	-	26	-	-	26	29
Min Flow - Freeze Inhibitor	gpm	492	557	-	-	492	-	-	492	557
	l/s	31	35	-	-	31	-	-	31	35
Maximum Flow	gpm	1807	2050	-	-	1807	-	-	1807	2050
	l/s	114	129	-	-	114	-	-	114	129
CONDENSER (all are 2-pass)										
Connection size	in	8	8	8	8	8	8	8	8	8
	mm	200	200	200	200	200	200	200	200	200
Water Storage	gal	79	97	47	61	79	47	61	79	97
	L	299	367	178	231	299	178	231	299	367
Min Flow - Water	gpm	444	589	316	385	444	316	385	444	589
	l/s	28	37	20	24	28	20	24	28	37
Min Flow - Freeze Inhibitor	gpm	530	710	380	460	530	380	460	530	710
	l/s	33	45	24	29	33	24	29	33	45
Max Flow	gpm	1960	2600	1390	1700	1960	1390	1700	1960	2600
	l/s	124	164	88	107	124	88	107	124	164

(a) Unit configuration digits 1, 2 - compressor code (also shown in unit model number digits 6, 7); digits 3, 4 - evaporator code (unit model number digits 14, 15); digits 5, 6 - condenser code (unit model number digits 21, 22).

(b) If oil cooler is installed, add 0.3 gal (1L) to oil charge value given for B compressor family units. Add 1.0 gal (4L) for all other units.



Pre-Installation

Inspection

When the unit is delivered, verify that it is the correct unit and that it is properly equipped.

Inspect all exterior components for visible damage. Report any apparent damage or material shortage to the carrier and make a "unit damage" notation on the carrier's delivery receipt. Specify the extent and type of damage found and notify the appropriate Trane Sales Office.

Do not proceed with installation of a damaged unit without sales office approval.

46 psig at 50°F), call a qualified service organization and the appropriate Trane sales office.

Note: *Pressure will be approximately 20 psig if shipped with the optional nitrogen charge.*

Inspection Checklist

To protect against loss due to damage incurred in transit, complete the following checklist upon receipt of the unit.

- Inspect the individual pieces of the shipment before accepting the unit. Check for obvious damage to the unit or packing material.
- Inspect the unit for concealed damage as soon as possible after delivery and before it is stored. Concealed damage must be reported within 10 days after receipt.
- If concealed damage is discovered, stop unpacking the shipment. Do not remove damaged material from the receiving location. Take photos of the damage, if possible. The owner must provide reasonable evidence that the damage did not occur after delivery.
- Notify the carrier's terminal of the damage immediately, by phone and by mail. Request an immediate, joint inspection of the damage with the carrier and the consignee.
- Notify the Trane sales representative and arrange for repair. Do not repair the unit, however, until damage is inspected by the transportation representative.

Loose Parts Inventory

Check all items against the shipping list. Water vessel drain plugs, isolation pads, rigging and electrical diagrams, service literature and the starter/control panel wire pullbox (required on some starters) are shipped loose in the control panel.

Storage

If the chiller is to be stored more than one month prior to installation, observe the following precautions:

- Do not remove the protective coverings from the electrical panel.
- Store the chiller in a dry, secure area.
- At least every three months, attach a gauge and manually check the pressure in the refrigerant circuit. If the refrigerant pressure is below 71 psig at 70°F (or

Installation Requirements

A list of the contractor responsibilities typically associate with the unit installation process is provided in [Table 4](#).

Table 4. Installation requirements

Requirement	Trane Supplied, Trane Installed	Trane Supplied, Field Installed	Field Supplied, Field Installed
Rigging			<ul style="list-style-type: none"> Safety chains Clevis connectors - Lifting beam
Disassembly/ Reassembly (as required) ^(a)	<ul style="list-style-type: none"> Trane, or an agent of Trane specifically authorized to perform start-up of Trane® products (contact your local Trane office for pricing) 		
Isolation		<ul style="list-style-type: none"> Isolation pads 	<ul style="list-style-type: none"> Isolation pads
Electrical	<ul style="list-style-type: none"> Circuit breakers or non-fused disconnects (optional) Unit-mounted starter 	<ul style="list-style-type: none"> Circuit breaker or non-fused disconnect handle Temperature sensor (optional outdoor air) Flow switches (may be field-supplied) Condenser water regulating valve controller (optional: may be field-supplied) 	<ul style="list-style-type: none"> Circuit breakers or fusible disconnects (optional) Terminal lugs Ground connection(s) Jumper bars BAS wiring (optional) IPC wiring Control voltage wiring High condenser pressure interlock wiring Chilled water pump contactor and wiring Condenser water pump contactor and wiring Optional relays and wiring
Water piping		<ul style="list-style-type: none"> Flow switches (may be field-supplied) Condenser water regulating valve controller (optional- may be field-supplied) 	<ul style="list-style-type: none"> Thermometers Water flow pressure gauges Isolation and balancing valves in water piping Vents and drain valves Pressure relief valves (for water boxes as required)
Pressure Relief	<ul style="list-style-type: none"> Relief valves 		Vent line and flexible connector
Insulation	<ul style="list-style-type: none"> Insulation (optional) 		Insulation
Optimus™ RTHD Installation Completion Check Sheet and Request for Trane Service (RLC-ADF005*-EN, see "Log and Check Sheets," p. 95)			
Chiller Start-up Commissioning ^(b)	<ul style="list-style-type: none"> Trane, or an agent of Trane specifically authorized to perform start-up of Trane® products 		

(a) Trane, or an agent of Trane specifically authorized to perform start-up and warranty of Trane® products, will perform or have direct on-site supervision of the disassembly and reassembly work.

(b) Start-up must be performed by Trane or an agent of Trane specifically authorized to perform start-up and warranty of Trane® products. Contractor shall provide Trane (or an agent of Trane specifically authorized to perform start-up) with notice of the scheduled start-up at least two weeks prior to the scheduled start-up.



Dimensions and Weights

Unit Dimensions

See unit submittals for specific unit dimensions and water connection locations.

Unit Weights

Table 5. Weights — standard units (wye-delta starter)

Unit Configuration ^(a)	Shipping Weight		Operating Weight	
	lbs	kg	lbs	kg
B1B1B1	9,292	4,215	9,867	4,476
B1C1D1	9,837	4,462	10,554	4,787
B2B2B2	9,402	4,265	10,019	4,545
B2C2D2	9,953	4,515	10,653	4,832
C1D5E4	12,973	5,884	13,673	6,202
C1D6E5	12,780	5,797	13,397	6,077
C1E1F1	14,718	6,676	15,818	7,175
C2D3E3	14,002	6,351	15,044	6,824
C2D4E4	12,972	5,884	13,672	6,201
C2F2F3	16,168	7,334	17,560	7,965
D1D1E1	14,443	6,551	15,385	6,987
D1F1F2	16,187	7,342	17,537	7,955
D1G1G1	18,600	8,437	20,500	9,299
D1G2G2	19,107	8,667	21,065	9,555
D2D2E2	14,562	6,605	15,570	7,062
D2F2F3	16,820	7,629	18,220	8,264
D2G2G1	18,700	8,482	20,700	9,389
D2G3G3	19,508	8,849	21,641	9,816
D3D2E2	14,562	6,605	15,570	7,062
D3F2F3	16,820	7,629	18,220	8,264
D3G2G1	18,650	8,460	20,650	9,367
E3D2E2	14,720	6,677	15,728	7,134
E3F2F3	16,956	7,691	18,356	8,326
E3G2G1	18,800	8,528	20,800	9,435
E3G3G3	19,653	8,915	21,786	9,882

Notes:

1. All weights +/- 3%
2. Shipping weights include standard 150 psig water boxes, refrigerant charge and oil charge.
3. Operating weights include refrigerant, oil and water charges.

(a) Unit configuration digits 1, 2 - compressor code (also shown in unit model number digits 6, 7); digits 3, 4 - evaporator code (unit model number digits 14, 15); digits 5, 6 - condenser code (unit model number digits 21, 22).

Table 6. Weights — units with AFD option^(a)

Unit Configuration ^(b)	Shipping Weight				Operating Weight			
	AFD D1H Frame		AFD D2H Frame		AFD D1H Frame		AFD D2H Frame	
	lbs	kg	lbs	kg	lbs	kg	lbs	kg
B1B1B1	9526	4321	9664	4384	10101	4582	10239	4645
B1C1D1	10071	4568	10209	4631	10787	4893	10925	4956
B2B2B2	9636	4371	9774	4434	10251	4650	10389	4713
B2C2D2	10187	4621	10325	4684	10886	4938	11024	5001
C1D5E4	13206	5990	13344	6053	13904	6307	14043	6370
C1D6E5	13014	5903	13153	5966	13631	6183	13770	6246
C1E1F1	14949	6781	15088	6844	16801	7621	16940	7684
C2D3E3	14235	6457	14374	6520	15278	6930	15417	6993
C2D4E4	13206	5990	13344	6053	13907	6308	14046	6371
C2F2F3	17055	7736	17194	7799	18446	8367	18585	8430
D1D1E1	-	-	14815	6720	-	-	15756	7147
D1F1F2	-	-	16559	7511	-	-	17910	8124
D1G1G1	-	-	18973	8606	-	-	20873	9468
D1G2G2	-	-	19480	8836	-	-	21438	9724
D2D2E2	-	-	14934	6774	-	-	15944	7232
D2F2F3	-	-	17194	7799	-	-	18594	8434
D2G2G1	-	-	19072	8651	-	-	21074	9559
D2G3G3	-	-	19881	9018	-	-	22013	9985
D3D2E2	-	-	14934	6774	-	-	15944	7232
D3F2F3	-	-	17194	7799	-	-	18594	8434
D3G2G1	-	-	19023	8629	-	-	21023	9536
E3D2E2	-	-	15093	6846	-	-	16100	7303
E3F2F3	-	-	17337	7864	-	-	18728	8495
E3G2G1	-	-	19173	8697	-	-	21173	9604
E3G3G3	-	-	20036	9088	-	-	22169	10056

Notes:

1. All weights +/- 3%
2. Shipping weights include standard 150 psig water boxes, refrigerant charge and oil charge.
3. Operating weights include refrigerant, oil and water charges.
4. AFD frame size determined by unit selection. See submittal for information.

(a) Weights vary with AFD frame size. D1H frame size used on units with model number digit 44 = G, H, J, V, W, X, 2, 3, or 4. D2H frame size used with model number digit 44 = K, L, M, N, Y, Z, 1, 5, 6, or 7.

(b) Unit configuration digits 1, 2 - compressor code (also shown in unit model number digits 6, 7); digits 3, 4 - evaporator code (unit model number digits 14, 15); digits 5, 6 - condenser code (unit model number digits 21, 22).

Service Clearances

Notes:

- Required vertical clearance above unit is 36" (914 mm). There should be no piping or conduit located over the compressor motor.
- Maximum clearances are given. Some units configurations may require less clearance than others in the same category.
- If the room configuration requires a variance to the clearance dimensions, contact your Trane sales office representative.

Figure 5. Service clearances^(a)

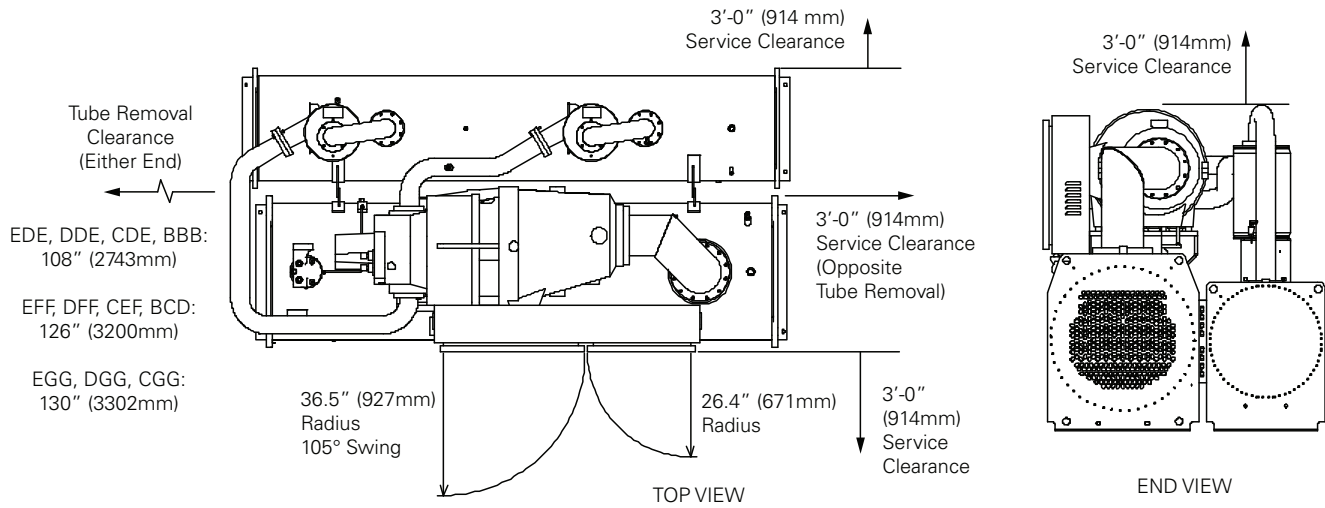

(a) Optional AFD is not shown. See [Figure 3, p. 13](#) for location of optional AFD.



Installation Mechanical

Location Requirements

Sound Considerations

Note: See Trane Engineering Bulletin Sound Ratings and Installation Guide Optimus™ Water-Cooled Chillers RLC-PRB015*-EN for sound consideration applications.

- Locate the unit away from sound-sensitive areas.
- Install the isolation pads under the unit. Refer to “Unit Isolation.”
- Install rubber vibration isolators in all water piping.
- Isolate all pipe hangers and be sure they are not supported by main structure beams that could introduce vibration into occupied spaces.
- Make sure that the piping does not put additional stress on the unit.

Note: Do not use metal braided type eliminators on the water piping. Metal braided eliminators are not effective at the frequencies at which the unit will operate.

- Use flexible electrical conduit.
- Seal all wall penetrations.

Note: Consult an acoustical engineer for critical applications.

Foundation

Provide rigid, non-warping mounting pads or a concrete foundation of sufficient strength and mass to support the chiller operating weight (including completed piping and full operating charges of refrigerant, oil and water). See Table 5, p. 16 or Table 6, p. 17 for unit operating weights.

Place the manufacturer-supplied isolation pad assemblies under the unit. Once in place, level the chiller within 1/4” (6.35 mm) over its length and width.

The Trane Company is not responsible for equipment problems resulting from an improperly designed or constructed foundation.

Clearances

Provide enough space around the unit to allow the installation and maintenance personnel unrestricted access to all service points. Refer to submittal drawings for the unit dimensions.

See Figure 5, p. 18 for minimum clearances required for service. In all cases, local codes will take precedence over these recommendations.

Ventilation

The unit produces heat even though the compressor is cooled by the refrigerant. Make provisions to remove heat generated by unit operation from the equipment room.

Ventilation must be adequate to maintain an ambient temperature lower than the following:

Wye-Delta Starter Units:	104°F (40°C)
AFD Unit Option:	104°F (40°C)

Vent the evaporator, condenser and compressor pressure relief valves in accordance with all local and national codes. See Table 10, p. 35

Make provisions in the equipment room to keep the chiller from being exposed to freezing temperatures (32°F/0°C).

Water Drainage

Locate the unit near a large capacity drain for water vessel drain-down during shutdown or repair. Condensers and evaporators are provided with drain connections. See Figure 4, p. 32. All local and national codes apply.

Access Restrictions

Door clearances are given in Figure 5, p. 18. See unit submittals for specific “per unit” dimensional information.

Rigging

Important: If unit must be disassembled for installation, see Engineering Bulletin RTHD-SVB02*-EN, Disassembly Procedure, Optimus™ Water-Cooled Chillers, for instructions, including weights and rigging instruction for components.

The Optimus™ chiller should be moved by lifting at designated lift points only. See Table 5, p. 16 and Table 6, p. 17 for overall unit weights. See Figure 6, p. 20 and Table 7, p. 20 for typical unit lifting point weights.

⚠ WARNING

Heavy Objects!

Failure to follow instructions below or properly lift unit could result in unit dropping and possibly crushing operator/technician which could result in death or serious injury, and equipment or property-only damage. Ensure that all the lifting equipment used is properly rated for the weight of the unit being lifted. Each of the cables (chains or slings), hooks, and shackles used to lift the unit must be capable of supporting the entire weight of the unit. Lifting cables (chains or slings) may not be of the same length. Adjust as necessary for even unit lift.

Figure 6. Lifting location point weights and dimensions^(a)

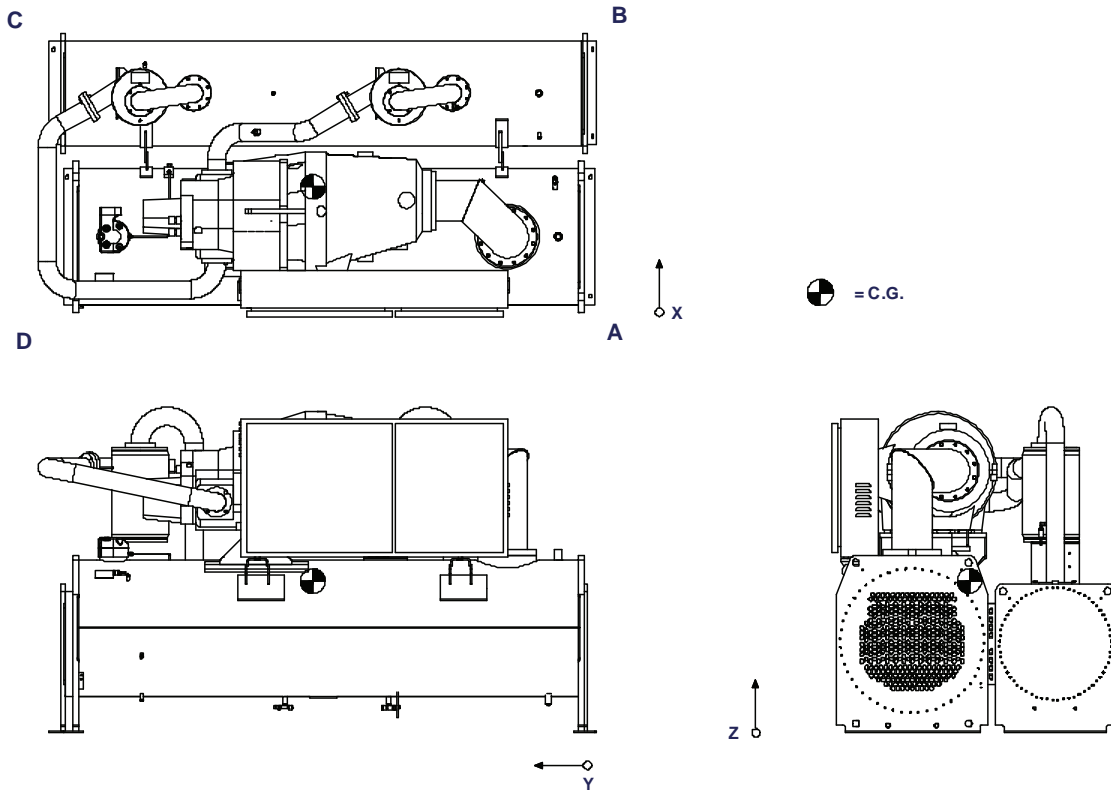

(a) Optional AFD is not shown. See [Figure 3, p. 13](#) for location of optional AFD. Lifting weights and center of gravity measurements are shown for both unit configurations in tables below.

Table 7. Lifting weights

Unit Designator ^(a)	Units	Location							
		Wye-Delta Units				AFD Units			
		A	B	C	D	A	B	C	D
B1B1B1	lb	2495	1969	1901	2928	2611	1969	1900	3184
	kg	1132	893	862	1328	1184	893	862	1445
B1C1D1	lb	3136	2264	1739	2698	3274	2264	1739	2931
	kg	1422	1027	789	1224	1485	1027	789	1330
B2B2B2	lb	2522	1996	1926	2958	2637	1995	1927	3215
	kg	1144	905	874	1342	1196	905	874	1459
B2C2D2	lb	3162	2297	1767	2726	2661	1995	1927	3191
	kg	1510	1042	802	1237	1207	905	874	1448
C1D5E4	lb	3375	2479	2876	4243	3472	2478	2877	4520
	kg	1531	1124	1305	1925	1575	1124	1305	2050
C1D6E5	lb	3330	2430	2825	4195	3426	2429	2824	4471
	kg	1510	1102	1281	1903	1554	1102	1281	2028
C1E1F1	lb	4205	3046	3196	4271	4339	3047	3197	4509
	kg	1907	1382	1450	1937	1968	1382	1450	2045
C2D3E3	lb	3612	2738	3148	4503	3708	2738	3148	4780
	kg	1638	1242	1428	2043	1682	1242	1428	2168
C2D4E4	lb	3374	2479	2876	4243	3470	2478	2877	4520
	kg	1530	1124	1305	1925	1574	1124	1305	2050
C2F2F3	lb	4649	3496	4707	4707	4786	3497	4707	4943
	kg	2109	1586	2135	2135	2171	1586	2135	2242
D1D1E1	lb	3728	2758	3236	4694	3825	2758	3236	4970
	kg	1691	1251	1468	2129	1735	1251	1468	2254

Table 7. Lifting weights (continued) (continued)

Unit Designator ^(a)	Units	Location							
		Wye-Delta Units				AFD Units			
		A	B	C	D	A	B	C	D
D1F1F2	lb	4526	3452	3615	4594	4662	3452	3616	4831
	kg	2053	1566	1640	2084	2115	1566	1640	2191
D1G1G1	lb	4981	4148	4041	5076	5116	4149	4041	5312
	kg	2259	1882	1833	2302	2320	1882	1833	2410
D1G2G2	lb	5216	4344	4231	5316	5679	4359	4100	5342
	kg	2366	1970	1919	2411	2576	1977	1860	2423
D2D2E2	lb	3754	2818	3269	4720	3851	2818	3269	4996
	kg	1703	1278	1483	2141	1747	1278	1483	2266
D2F2F3	lb	4737	3563	3722	4797	4874	3563	4797	5034
	kg	2149	1616	2176	2176	2211	1616	2176	2283
D2G2G1	lb	5085	4255	4136	5171	5221	4255	4136	5409
	kg	2307	1930	1876	2346	2368	1930	1876	2454
D2G3G3	lb	5320	4451	4327	5140	5715	4511	4259	5396
	kg	2413	2019	1963	2331	2592	2046	1932	2448
D3D2E2	lb	3754	2818	3269	4720	3851	2818	3269	4996
	kg	1703	1278	1483	2141	1747	1278	1483	2266
D3F2F3	lb	4737	3563	3722	4797	4874	3563	3721	5034
	kg	2149	1616	1688	2176	2211	1616	1688	2283
D3G2G1	lb	5085	4255	4136	5171	5221	4255	4136	5409
	kg	2307	1930	1876	2346	2368	1930	1876	2454
E3D2E2	lb	3796	2834	3300	4789	3904	2833	3300	5053
	kg	1722	1285	1497	2172	1771	1285	1497	2292
E3F2F3	lb	4781	3582	3750	4851	5918	3583	3750	5087
	kg	2169	1625	1701	2200	2231	1625	1701	2307
E3G2G1	lb	5158	4304	4226	5300	5294	4303	4226	5537
	kg	2340	1952	1917	2404	2401	1952	1917	2512
E3G3G3	lb	5339	4455	4374	5486	5479	4454	4374	5729
	kg	2422	2021	1984	2488	2485	2020	1984	2599

(a) Unit designator (digits 6, 7, 14, 15, 21 and 22 of unit model number)



Installation Mechanical

Table 8. Center of gravity

Unit Configuration ^(a)	Units	Wye-Delta Units			AFD Units		
		X	Y	Z	X	Y	Z
B1B1B1	in	22.84	58.13	35.59	22.2	56.4	36.0
	mm	580	1477	904	563	1433	915
B1C1D1	in	22.32	58.23	33.65	21.7	57.2	34.1
	mm	567	1479	855	552	1454	866
B2B2B2	in	22.88	58.11	35.43	22.2	56.4	35.9
	mm	581	1476	900	564	1433	911
B2C2D2	in	22.4	58.29	33.51	21.0	62.1	33.9
	mm	569	1481	851	535	1578	862
C1D5E4	in	26.13	59.74	40.08	24.9	59.7	43.0
	mm	664	1517	1018	633	1515	1093
C1D6E5	in	26.13	59.74	40.08	24.8	59.7	40.6
	mm	664	1517	1018	630	1516	1032
C1E1F1	in	26.36	63.49	40.95	25.7	64.3	41.4
	mm	670	1613	1040	652	1633	1052
C2D3E3	in	26.13	59.74	40.08	25.4	59.4	40.6
	mm	664	1517	1018	646	1508	1031
C2D4E4	in	26.13	59.74	40.08	24.9	59.7	40.6
	mm	664	1517	1018	633	1515	1032
C2F2F3	in	27.92	63.47	38.7	30.5	70.7	39.2
	mm	709	1612	9833	774	1795	995
D1D1E1	in	25.91	60	40.47	25.1	59.6	41.0
	mm	658	1524	1028	638	1514	1040
D1F1F2	in	27.92	63.47	38.7	27.3	64.2	39.2
	mm	709	1612	983	693	1631	996
D1G1G1	in	30.58	68.56	37.79	29.6	62.1	38.2
	mm	777	1741	960	753	1577	971
D1G2G2	in	30.77	63.55	37.72	29.6	62.1	38.2
	mm	782	1614	958	753	1577	971
D2D2E2	in	25.97	59.95	40.31	25.3	59.6	40.8
	mm	660	1523	1024	643	1513	1036
D2F2F3	in	27.7	63.4	38.14	31.1	72.0	38.6
	mm	704	1610	969	789	1829	981
D2G2G1	in	30.58	68.56	37.79	30.2	63.0	38.2
	mm	777	1741	960	767	1601	971
D2G3G3	in	30.85	63.48	37.44	30.2	63.0	38.2
	mm	784	1612	951	767	1601	971
D3D2E2	in	25.97	59.95	40.31	25.3	59.6	40.8
	mm	660	1523	1024	643	1513	1036
D3F2F3	in	27.7	63.4	38.14	27.1	64.1	38.6
	mm	704	1610	969	687	1628	981
D3G2G1	in	30.58	68.56	37.79	30.3	63.2	38.2
	mm	777	1741	960	769	1605	971
E3D2E2	in	25.9	60.05	40.5	25.3	59.6	41.0
	mm	658	1525	1029	642	1513	1041
E3F2F3	in	27.64	63.46	38.33	27.0	64.2	38.8
	mm	702	1612	974	686	1630	986
E3G2G1	in	30.8	63.55	38.70	30.5	64.1	39.1
	mm	732	1614	983	776	1628	994
E3G3G3	in	30.8	63.91	37.62	30.2	63.5	39.4
	mm	782.32	1621	956	767	1613	1001

(a) Unit designator (digits 6, 7, 14, 15, 21 and 22 of unit model number).

Lifting Procedure

Figure 7. Rigging configuration^(a)

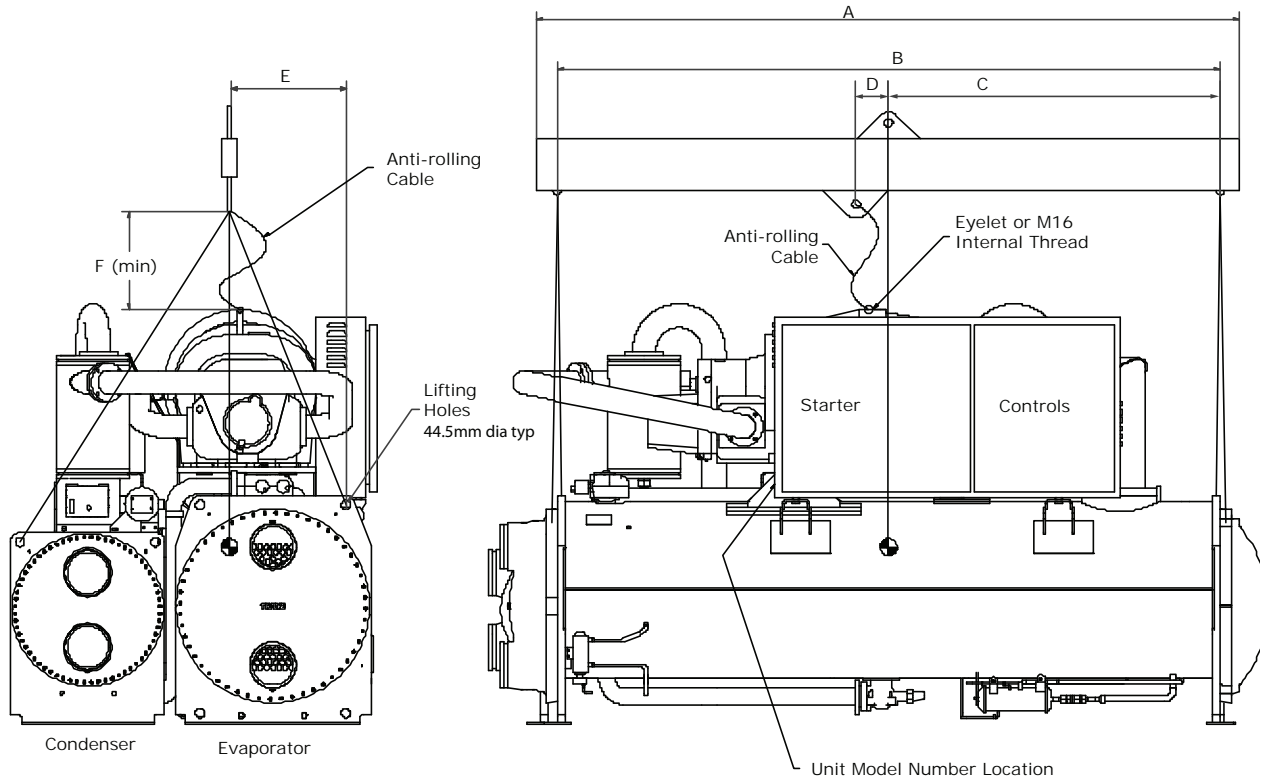

(a) Optional AFD is not shown. See [Figure 3, p. 13](#) for location of optional AFD. Rigging information is same for wye-delta or AFD units.

Table 9. Rigging dimensions

Unit Configuration ^(a)	Units	Dimension - in (mm)					
		A	B	C	D	E	F
B1B1B1	in	120	108	56.97	3.92	21.02	24
	mm	3048	2743	1447	97	534	610
B1C1D1	in	144	132	58.23	3.74	20.51	24
	mm	3658	3353	1479	95	521	610
B2B2B2	in	120	108	58.11	3.86	21.06	24
	mm	3048	2743	1476	98	535	610
B2C2D2	in	144	132	58.31	3.66	20.59	24
	mm	3658	3353	1481	93	523	610
C1D5E4	in	120	108	59.96	8.62	22.99	24
	mm	3048	2743	1523	219	584	610
C1D6E5	in	120	108	60	8.58	22.91	24
	mm	3048	2743	1524	218	582	610
C1E1F1	in	144	132	63.50	5.08	24.57	24
	mm	3658	3353	1613	129	624	610
C2D3E3	in	120	108	59.72	8.86	24.33	24
	mm	3048	2743	1517	225	618	610
C2D4E4	in	120	108	59.96	8.62	22.99	24
	mm	3048	2743	1523	219	584	610
C2F2F3	in	144	132	63.4	3.98	24.29	24
	mm	3658	3353	1610	101	617	610



Installation Mechanical

Table 9. Rigging dimensions (continued)

Unit Configuration ^(a)	Units	Dimension - in (mm)					
		A	B	C	D	E	F
D1D1E1	in	120	108	60	7.36	24.09	24
	mm	3048	2743	1524	187	612	610
D1F1F2	in	144	132	63.46	3.9	24.49	24
	mm	3658	3353	1612	99	622	610
D1G1G1	in	144	132	63.46	3.9	25.75	24
	mm	3658	3353	1612	99	654	610
D1G2G2	in	144	132	63.54	3.82	26.02	24
	mm	3658	3353	1614	97	661	610
D2D2E2	in	120	108	59.96	7.4	24.17	24
	mm	3048	2743	1523	188	614	610
D2F2F3	in	144	132	63.39	3.98	24.29	24
	mm	3658	3353	1610	101	617	610
D2G2G1	in	144	132	63.46	3.9	25.75	24
	mm	3658	3353	1612	99	654	610
D2G3G3	in	144	132	63.46	3.9	25.75	24
	mm	3658	3353	1612	99	654	610
D3D2E2	in	120	108	60	7.4	24.17	24
	mm	3048	2743	1523	188	614	610
D3F2F3	in	144	132	63.39	3.98	24.29	24
	mm	3658	3353	1610	101	617	610
D3G2G1	in	144	132	63.46	3.9	25.75	24
	mm	3658	3353	1612	99	654	610
E3D2E2	in	120	108	60	4.57	24.09	24
	mm	3048	2743	1525	116	612	610
E3F2F3	in	144	132	63.46	1.14	24.21	24
	mm	3658	3353	1612	29	615	610
E3G2G1	in	144	132	63.82	0.79	26	24
	mm	3658	3353	1621	20	661	610

(a) Designator corresponds to digits 6, 7, 14, 15, 21 and 22 of model number.

Important: Rigging dimensions given in [Table 9](#) are given as a starting point reference. Lifting cables should be adjusted as necessary for even unit lift.

⚠ WARNING

Improper Unit Lift!

Failure to properly lift unit could result in unit dropping and possibly crushing operator/technician which could result in death or serious injury, and equipment or property-only damage. Test lift unit approximately 24 inches to verify proper center of gravity lift point. To avoid dropping of unit, reposition lifting point if unit is not level.

⚠ WARNING

Risk of Unit Tipping!

Failure to do so may result in death or serious injury should a lifting cable fail. Connect an anti-rotation strap between the lifting beam and compressor before lifting unit.

⚠ WARNING

Shipping Mounts!

Do not use the threaded holes in the compressor to lift or assist in lifting the unit. They are not intended for that purpose and could create a dangerous situation. Do not remove the wood mounts until the unit is in its final location. Removal of wood shipping mounts prior to unit final locating could result in death or serious injury or equipment damage.

NOTICE:

Equipment Damage!

Never use a forklift to move the unit. The skid is not designed to support the unit at any one point and using a forklift to move the equipment may cause unit damage. Always position the lifting beam so that cables do not contact the unit. Failure to do so may result in unit damage.

Note: If absolutely necessary, the chiller can be pushed or pulled across a smooth surface if it is bolted to wood shipping mounts.

1. See [Table 5, p. 16](#) or [Table 6, p. 17](#) for unit shipping weights. See [Table 7, p. 20](#) for weights at each lift location. See [Table 8, p. 22](#) for center of gravity information.

Note: Weights are typical for units with R-134a charge.

2. When unit is at its final location, remove shipping bolts that secure unit to wood base mounts.
3. Install clevis connectors in lifting holes provided on the unit. Attach lifting chains or cables to clevis connectors as shown in [Figure 7, p. 23](#). Each cable alone must be strong enough to lift the chiller.
4. Attach cables to lifting beam as shown in [Figure 7, p. 23](#). See [Table 9, p. 23](#) for rigging dimensions. The lifting beam crossbar must be positioned so the lifting cables do not contact unit piping or electrical panel enclosure.
5. Connect an anti-rotation strap or cable loosely between the lifting beam and the threaded coupling or eyelet provided at the top of the compressor. Use an eyebolt or clevis to secure the strap at the coupling or eyelet.

Important: The anti-rotation strap is not a lifting chain, but a safety device to ensure that the unit cannot tilt during lifting.

6. Lift from above, or jack the unit per “[Alternate Moving Method,](#)” [p. 26](#). Remove the base mounts.
7. During final positioning of the unit, place the isolation pads under the evaporator and condenser tube sheet supports as shown in [Figure 12, p. 26](#). See “[Isolation Pads,](#)” [p. 26](#) for information on isolation pads.
8. Level the unit as described in “[Unit Leveling,](#)” [p. 26](#).
9. The unit is shipped with spacers on the compressor mount that protect isolation pads during shipping and handling. Before the unit is operated, remove the spacers as indicated to prevent excessive noise.

- B Family Compressors:
 - Remove qty 1 puck-type spacer under discharge side of compressor (see [Figure 8](#)).
 - Remove qty 2 flat washer spacers under suction side of compressor (see [Figure 9](#)).

Note: Suction side of compressor WILL float.

Figure 8. Compressor shipping spacers B family (discharge side)

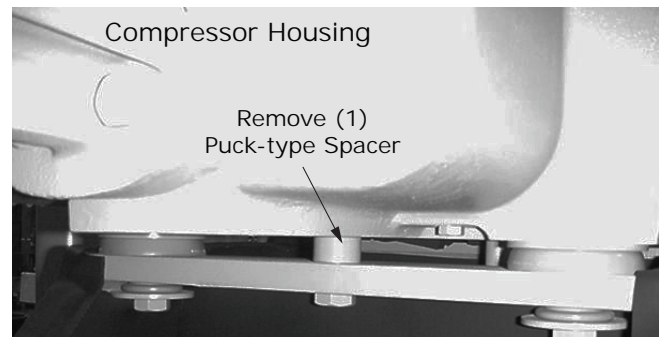
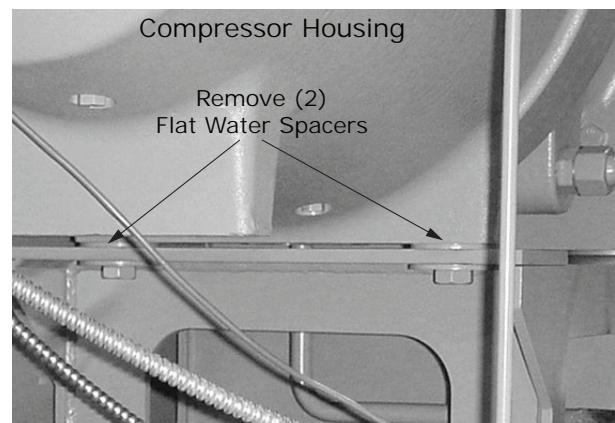
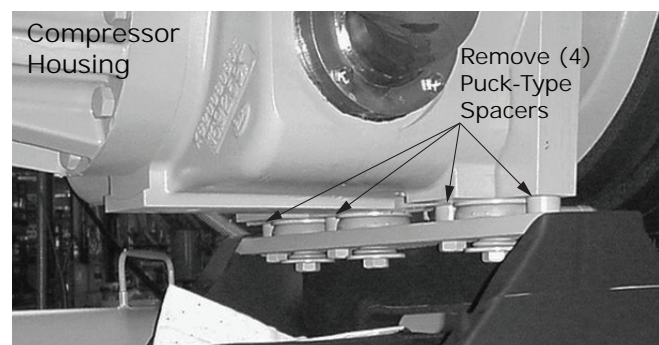

Figure 9. Compressor shipping spacers B family (suction side)



- C, D, E Family Compressors:
 - Remove (4) puck-type spacer under discharge side of compressor (see [Figure 10](#)).

Figure 10. Compressor shipping spacers C, D, E family (discharge side)



- Remove the shipping brackets from the bottom sides of the oil separator(s). See [Figure 11](#).

Figure 11. Oil separator shipping bracket

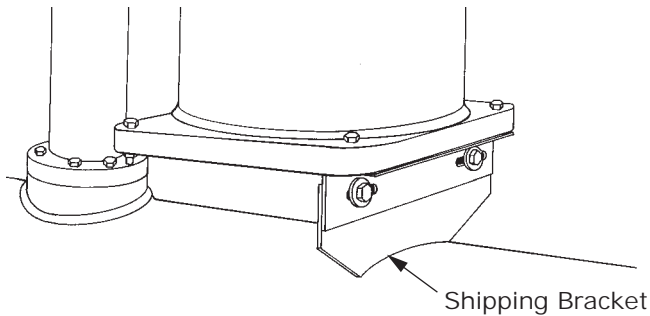

Notes:

- Once shipping bracket(s) is removed, the oil separator is only supported by the discharge line.
- Failure to remove oil separator shipping brackets could result in excessive noise.

Unit Leveling

Note: The electrical panel side of the unit is designated as the "front" of the unit.

- Check unit level end-to-end by placing a level on the top surface of the evaporator shell.
- If there is insufficient surface available on the top of evaporator shell, attach a magnetic level to bottom of

Figure 12. Isolator pad placement

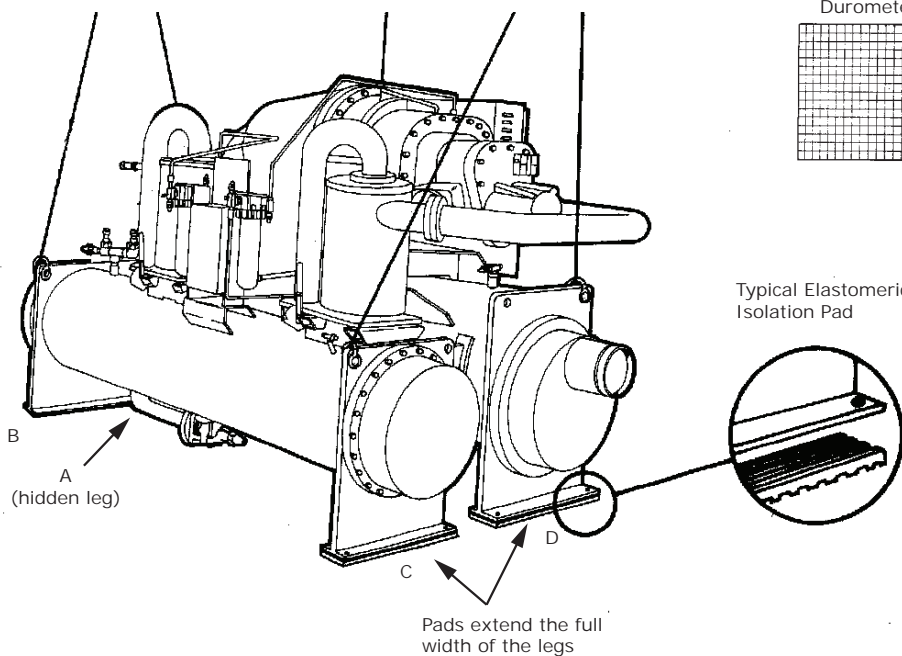

shell to level the unit. Unit should be level to within 1/4" (6.35 mm) over its length.

- Place the level on the evaporator shell tube sheet support to check side-to-side (front-to-back) level. Adjust to within 1/4" (6.35 mm) of level front-to-back.

Note: The evaporator **MUST** be level for optimum heat transfer and unit performance.

- Use full-length shims to level the unit.

Alternate Moving Method

If it is not possible to rig from above as shown in [Figure 7, p. 23](#), the unit may also be moved by jacking each end high enough to move an equipment dolly under each tube sheet support. Once securely mounted on the dollies, the unit may be rolled into position.

Isolation Pads

Notes:

- The elastomeric pads shipped (as standard) are adequate for most installations. For additional details on isolation practices, see *Trane Engineering Bulletin Sound Ratings and Installation Guide Optimus™ Water-Cooled Chillers RLC-PRB015*-EN*, or consult an acoustical engineer for sound-sensitive installations.
- Durometer values for isolator pads are a measure of resilience. See [Figure 12](#).

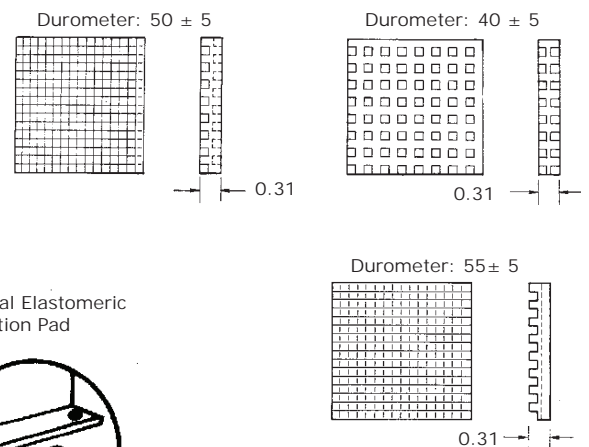

NOTE: Level unit to 1/4" (6.25mm) across length and width.

Water Pressure Drop Data

Evaporator Pressure Drop
G Frame - 3 Pass

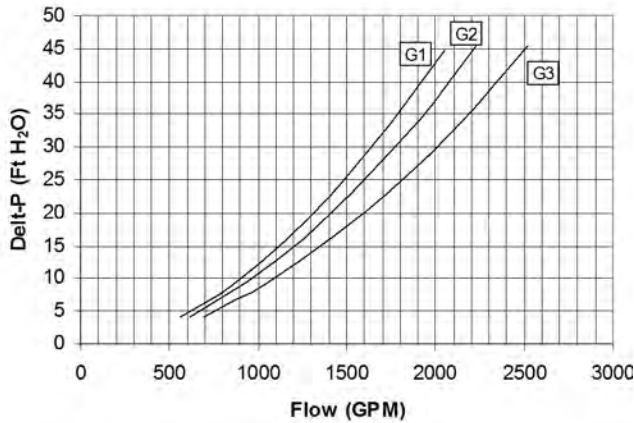

Evaporator Pressure Drop
F Frame - 2 Pass

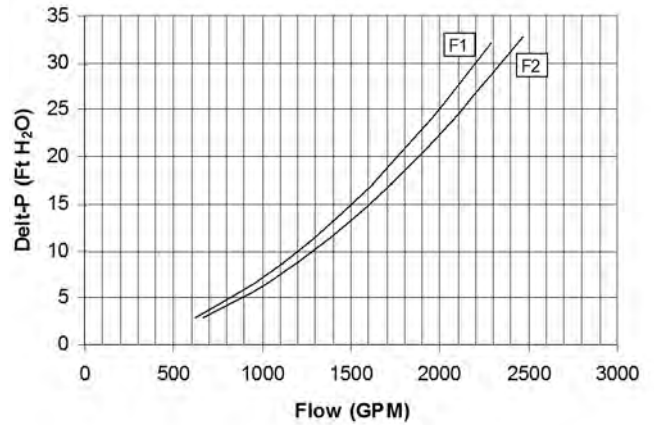

Evaporator Pressure Drop
G Frame - 4 Pass

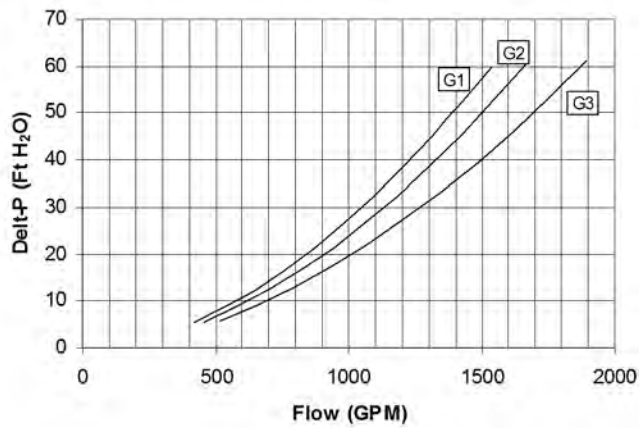

Evaporator Pressure Drop
F Frame - 3 Pass

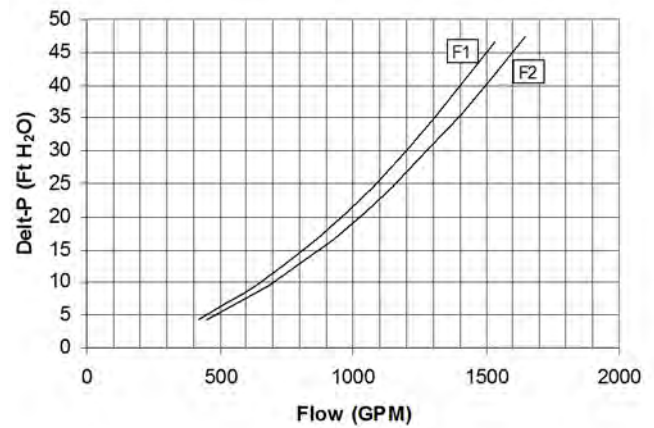



Installation Mechanical

Evaporator Pressure Drop E Frame - 2 Pass

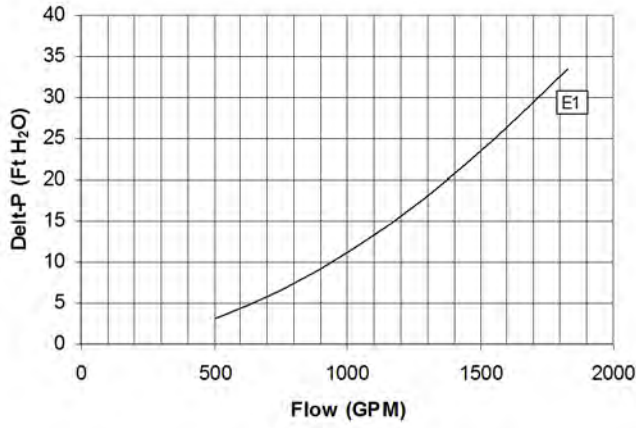

Evaporator Pressure Drop D Frame - 2 Pass

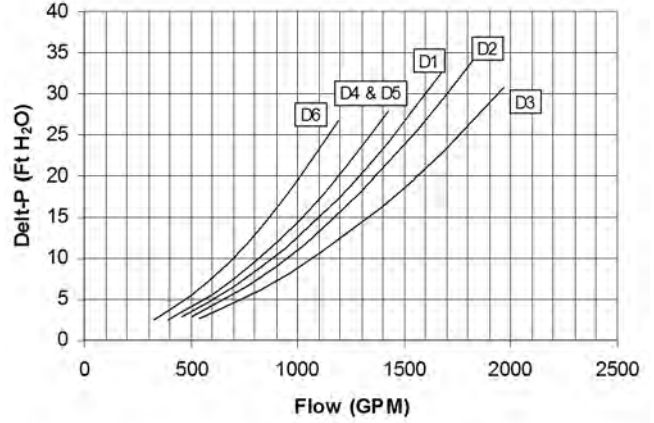

Evaporator Pressure Drop E Frame - 3 Pass

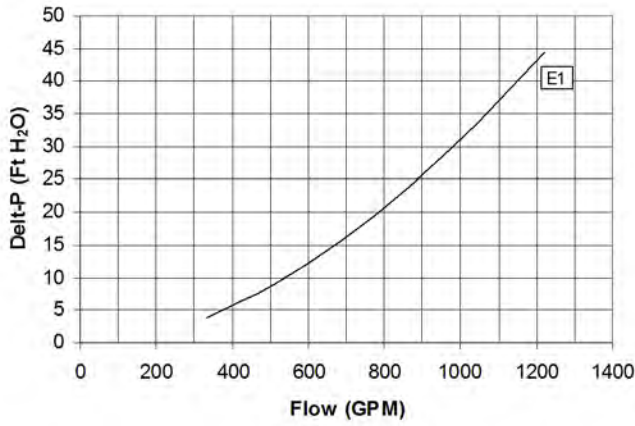

Evaporator Pressure Drop D Frame - 3 Pass

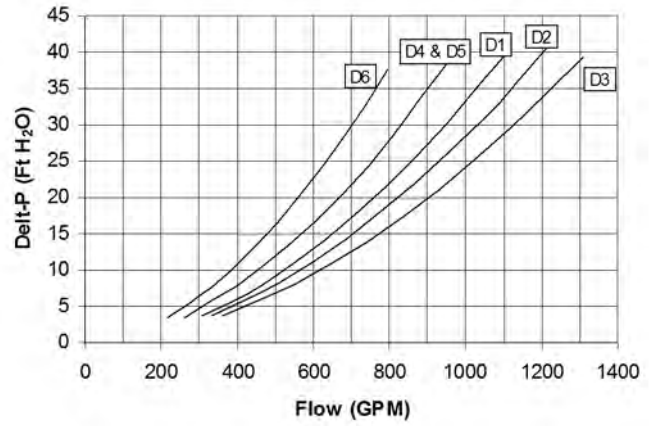

**Evaporator Pressure Drop
C Frame - 2 Pass**

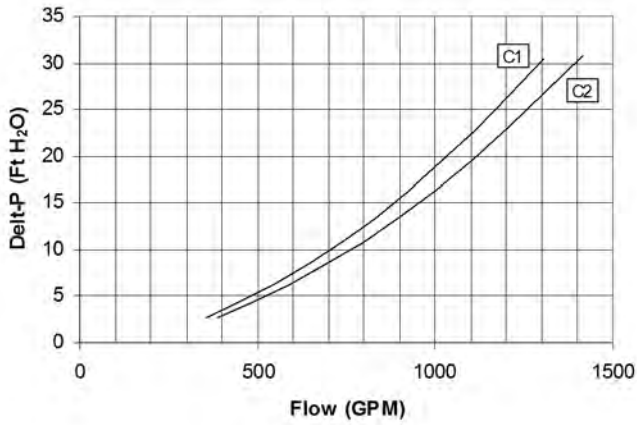

**Evaporator Pressure Drop
B Frame - 2 Pass**

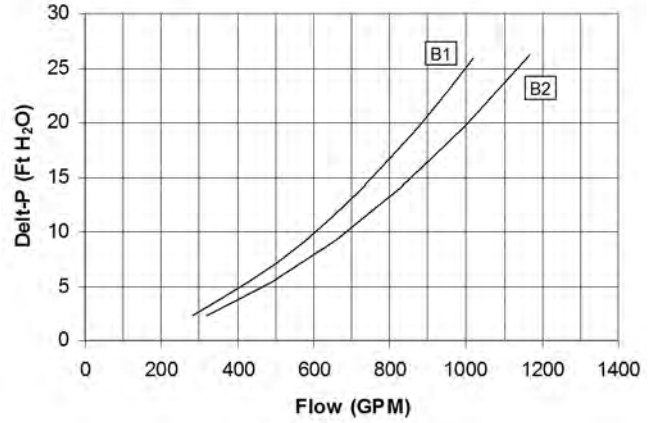

**Evaporator Pressure Drop
C Frame - 3 Pass**

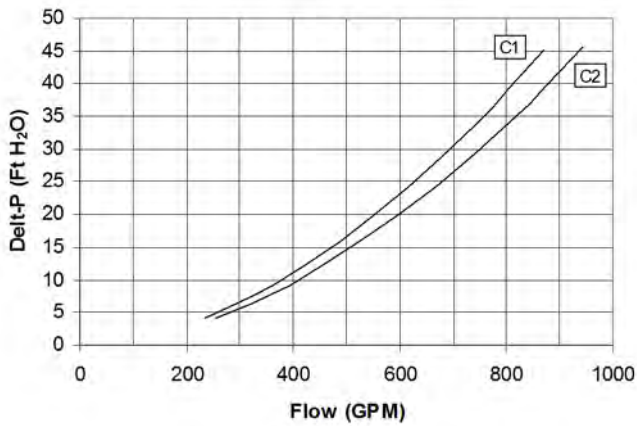

**Evaporator Pressure Drop
B Frame - 3 Pass**

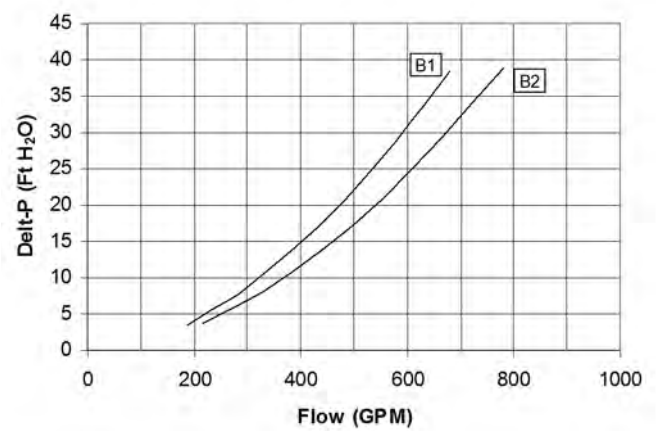



Installation Mechanical

Condenser Pressure Drop G Frame - 2 Pass

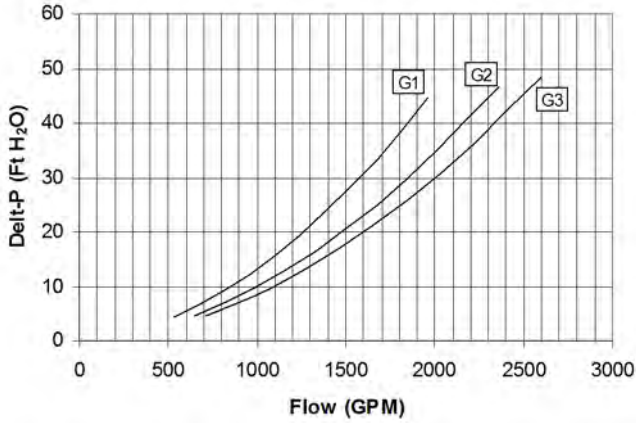

Condenser Pressure Drop D Frame - 2 Pass

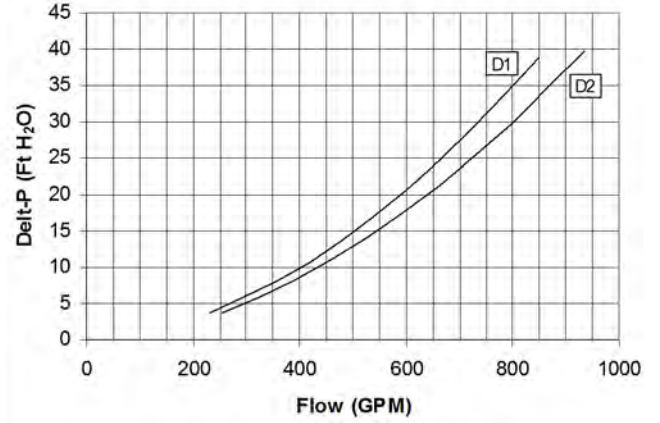

Condenser Pressure Drop F Frame - 2 Pass

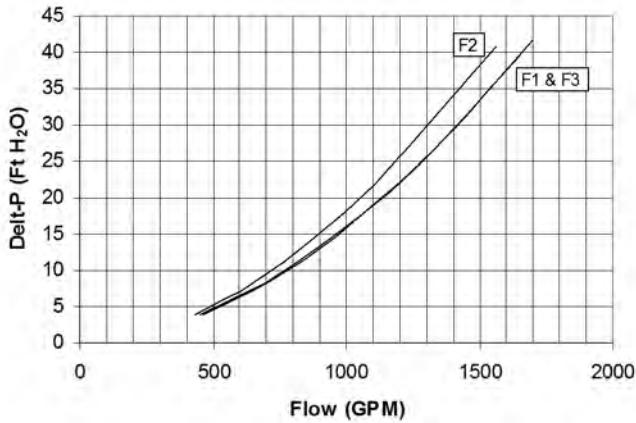

Condenser Pressure Drop B Frame - 2 Pass

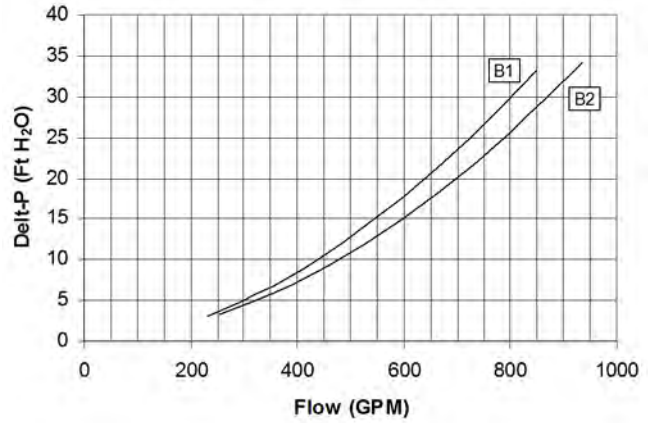

Condenser Pressure Drop E Frame - 2 Pass

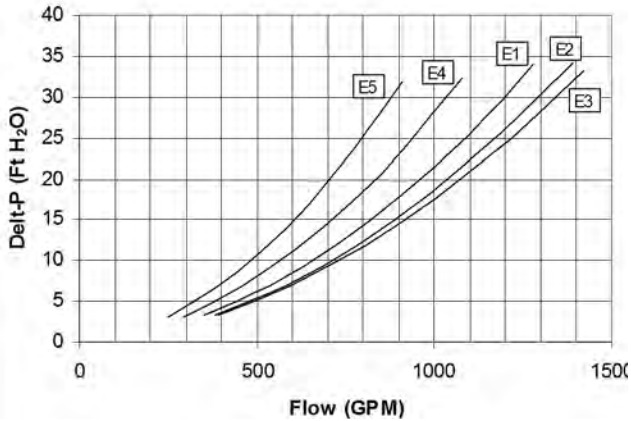

Water Piping

Figure 13. Typical water piping setup

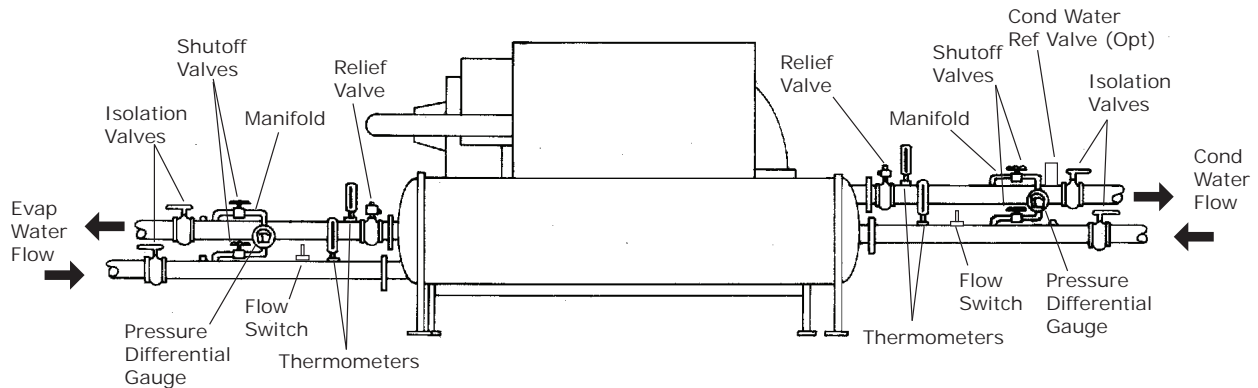

General

Note: Field piping must be arranged and supported to avoid stress on the equipment. It is strongly recommended that the piping contractor provide at least 3 feet (914 mm) of clearance between the pre-installation piping and the planned location of the unit. This will allow for proper fit-up upon arrival of the unit at the installation site. All necessary piping adjustments can be made at that time. Refer to the current engineering bulletin for further details on installation.

- Where specified, supply and install valves in the water piping upstream and downstream of the evaporator and condenser water boxes, to isolate the shells for maintenance and to balance/trim the system.
- Supply and install condenser water control valve(s) per Engineering Bulletin RLC-PRB017*-EN.
- Supply or locate ship-with flow switches. Install flow switches or equivalent devices in both the chilled water and condenser water piping. Wire the flow switches into the control system as indicated on the electrical schematics and field wiring diagrams, to ensure that the unit can only operate when water flow is established.
- Supply and install taps for thermometers and pressure gauges in water piping, adjacent to the inlet and outlet connections of both the evaporator and the condenser.
- Supply and install drain valves on each water box.
- Supply and install vent cocks on each water box.
- Where specified, supply and install strainers ahead of all pumps and automatic modulating valves.
- Supply and install refrigerant pressure relief piping from the pressure relief to the atmosphere.
- If necessary, supply enough R-134a refrigerant and dry nitrogen (75 psig) for pressure testing.
- Where specified, supply and insulate the evaporator and any other portion of the unit, as required, to prevent sweating under normal operating conditions.

Piping Connections

NOTICE:

Equipment Damage!

If using any commercial flushing/cleaning solution, construct a temporary bypass around the unit to prevent damage to internal components of the evaporator/condenser. Trane assumes no responsibility for equipment damage caused by flushing/cleaning solutions or water-borne debris.

Make water piping connections to the evaporator and condenser. Isolate and support piping to prevent stress on the unit. Construct piping according to local and national codes. Insulate and flush piping before connecting to unit.

Use grooved pipe connectors for all water piping connections. Evaporator and condenser water inlet and outlet sizes and locations are shown by the unit submittals. The designation in the tables corresponds to the compressor frame code followed by the evaporator shell code followed by the condenser shell code as given in the unit model number, digits 6, 7, 14, 15, 21 and 22. [Table 1, p. 11](#) through [Table 3, p. 13](#) list water connection information.

Reversing Waterboxes

All water boxes may be reversed end-for-end. See ["Maintenance Procedures," p. 79](#) for detailed waterbox removal instructions.

Remove sensors from wells before removing waterbox.

Do not rotate water boxes. See [Figure 14, p. 32](#) through [Figure 16, p. 32](#) for correct orientation of the water inlet and outlet.

Complete the water box switch and replace sensors.

Notes:

- If water boxes are reversed, be sure to properly rewire water temperature sensors in control panel.
- Be certain to replace water boxes right-side-up to maintain proper baffle orientation. Use new o-rings.

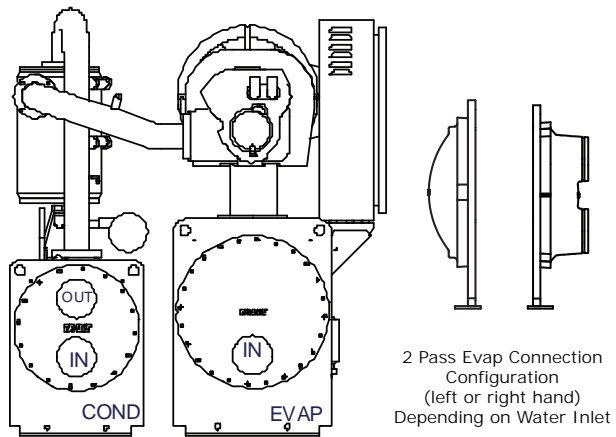
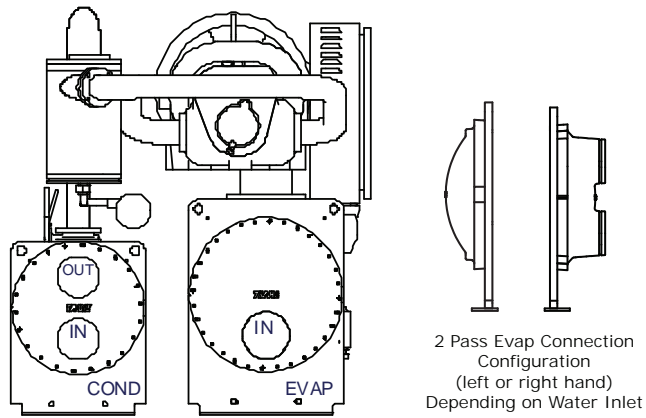
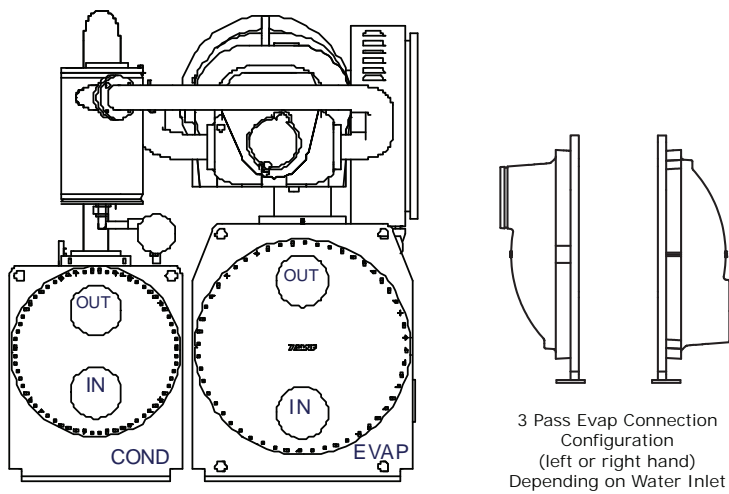
Figure 14. Condenser and evaporator waterboxes – BBB/BCD

Figure 15. Condenser and evaporator waterboxes – CEF/CDE/DDE/EDE/DFE/EFF/CFE

Figure 16. Condenser and evaporator waterboxes – DGG/EGG

Making Grooved Pipe Connections

NOTICE:

Equipment Damage!

To prevent damage to water piping, do not overtighten connections. To prevent equipment damage, bypass the unit if using an acidic flushing agent

Note: Make sure that all piping is flushed and cleaned prior to starting the unit.

Vents and Drains

Install pipe plugs in evaporator and condenser water box drain and vent connections before filling the water systems.

To drain water, remove vent and drain plugs, install a NPT connector in the drain connection with a shutoff valve and connect a hose to it.

Evaporator Piping Components

Note: Make sure all piping components are between the shutoff valves, so that isolation can be accomplished on both the condenser and the evaporator.

“Piping components” include all devices and controls used to provide proper water system operation and unit operating safety. These components and their general locations are given below.

Entering Chilled Water Piping

- Air vents (to bleed air from system)
- Water pressure gauges with shutoff valves
- Pipe unions
- Vibration eliminators (rubber boots)
- Shutoff (isolation) valves
- Thermometers
- Cleanout tees
- Pipe strainer
- Flow switch

Leaving Chilled Water Piping

- Air vents (to bleed air from system)
- Water pressure gauges with shutoff valves
- Pipe unions
- Vibration eliminators (rubber boots)
- Shutoff (isolation) valves
- Thermometers
- Cleanout tees
- Balancing valve
- Pressure relief valve

NOTICE:

Evaporator Damage!

To prevent evaporator damage, do not exceed 150 psig (10.3 bar) evaporator water pressure for standard water boxes. Maximum pressure for high pressure water boxes is 300 psig (20.7 bar). Refer to digit 14 of the Model No. To prevent tube damage, install a strainer in the evaporator water inlet piping. To prevent tube corrosion, ensure that the initial water fill has a balanced pH.

Condenser Piping Components

“Piping components” include all devices and controls used to provide proper water system operation and unit operating safety. These components and their general locations are given below.

Entering condenser water piping.

- Air vents (to bleed air from system)
- Water pressure gauges with shutoff valves
- Pipe unions
- Vibration eliminators (rubber boots)
- Shutoff (isolation) valves. One per each pass
- Thermometers
- Cleanout tees
- Pipe strainer
- Flow switch

Leaving condenser water piping.

- Air vents (to bleed air from system)
- Water pressure gauges with shutoff valves
- Pipe unions
- Vibration eliminators (rubber boots)
- Shutoff (isolation) valve - one per each pass
- Thermometers
- Cleanout tees
- Balancing valve
- Pressure relief valve.

NOTICE:

Condenser Damage!

To prevent condenser damage, do not exceed 150 psig (10.3 bar) water pressure for standard water boxes. Maximum pressure for high pressure water boxes is 300 psig (20.7 bar). Refer to digit 18 of the Model No. To prevent tube damage, install a strainer in condenser water inlet piping. To prevent tube corrosion, ensure that the initial water fill has a balanced pH.

Condenser Water Regulating Valve

The Condenser Head Pressure Control Option provides for a 0-10VDC (maximum range - a smaller range is adjustable) output interface to the customer's condenser water flow device. The condenser water flow device is typically a large butterfly type (6" or 8") automatic valve for 200 to 400 Ton chillers.

The following guidelines must be met to ensure adequate oil circulation throughout the system.

- The chiller must maintain a 23 psid system pressure differential at all load conditions in order to ensure adequate oil circulation.
- The entering condenser water temperature must be above 55°F (12.8°C) or between 45°F (7.2°C) and 55°F (12.8°C) with a 1°F temperature rise per minute to 55°F (12.8°C).
- Condenser leaving water temperature must be 17°F degrees higher than evaporator leaving water temperature within 2 minutes of startup. A 25°F differential must be maintained thereafter.

If the above guidelines cannot be met, then some form of tower water control must be used.

Condenser Water Regulating Valve Adjustment

A separate Tracer® TU Settings Menu tab entitled "Condenser Head Pressure Control - Setup" that is only visible if the configuration is selected, contains the following settings and manual overrides for user adjustments and commissioning all under one tab:

- "Off State" Output Command (0-10 Vdc 0.1 volt increments, Default 2.0 Vdc)
- Output Voltage @ Desired Minimum Flow (Adj: 0 to 10.0 in 0.1 volt increments, Default 2.0 Vdc)
- Desired Minimum Flow (Adj: 0- 100% of full flow in 1% intervals, Default 20%)
- Output Voltage @ Desired Maximum Flow (Adj: 0 to 10.0 in 0.1 volt increments (or finer), Default 10 Vdc)
- Actuator Stroke Time (Min to Max Range Time) (Adj: 1 to 1000 seconds, in 1 second increments, Default 30s)
- Damping Coefficient (adj: 0.1 to 1.8, in 0.1 increments, Default 0.5)
- Head Pressure Control Override (enumeration of: disabled (auto), "off" state, minimum, maximum (100%)), default:disabled (auto). When this setting is in "disabled (auto)"

The following setting is found in the Setpoints tab:

- Condenser Water Pump Prestart Time

Water Treatment

NOTICE:

Proper Water Treatment!

The use of untreated or improperly treated water in a RTHD chiller could result in scaling, erosion, corrosion, algae or slime. It is recommended that the services of a qualified water treatment specialist be engaged to determine what water treatment, if any, is required. Trane assumes no responsibility for equipment failures which result from untreated or improperly treated water, or saline or brackish water.

Using untreated or improperly treated water in these units may result in inefficient operation and possible tube damage. Consult a qualified water treatment specialist to determine whether treatment is needed.

Water Pressure Gauges and Thermometers

Install field-supplied thermometers and pressure gauges (with manifolds, whenever practical) as shown in [Figure 13, p. 31](#). Locate pressure gauges or taps in a straight run of pipe; avoid placement near elbows, etc. Be sure to install the gauges at the same elevation on each shell if the shells have opposite-end water connections.

To read manifolded water pressure gauges, open one valve and close the other (depending upon the reading desired). This eliminates errors resulting from differently calibrated gauges installed at unmatched elevations.

Water Pressure Relief Valves

NOTICE:

Equipment Damage!

Install a pressure relief valve in both evaporator and condenser water systems. Failure to do so may result in shell damage.

Install a water pressure relief valve in one of the condenser and one of the evaporator water box drain connections or on the shell side of any shutoff valve. Water vessels with close-coupled shutoff valves have a high potential for hydrostatic pressure buildup on a water temperature increase. Refer to applicable codes for relief valve installation guidelines.

Flow Sensing Devices

Note: *The installer **must** provide flow switches or differential pressure switches with pump interlocks to sense system water flow. Flow switch locations are schematically shown in [Figure 13, p. 31](#).*

To provide chiller protection, install and wire flow switches in series with the water pump interlocks, for both chilled water and condenser water circuits (refer to the Installation Electrical section). Specific connections and schematic wiring diagrams are shipped with the unit.

Flow switches must stop or prevent compressor operation if either system water flow drops off below the required

minimum shown on the pressure drop curves. Follow the manufacturer's recommendations for selection and installation procedures. General guidelines for flow switch installation are outlined below.

- Mount the switch upright, with a minimum of 5 pipe diameters straight, horizontal run on each side.
- Do not install close to elbows, orifices or valves.

Note: The arrow on the switch must point in the direction of the water flow.

- To prevent switch fluttering, remove all air from the water system

Note: The UC800 provides a 6-second time delay on the flow switch input before shutting down the unit on a loss-of-flow diagnostic. Contact a qualified service organization if nuisance machine shutdowns persist.

- Adjust the switch to open when water flow falls below nominal. See "General Information," p. 9, general data tables for minimum flow recommendations for specific water pass arrangements. Flow switch contacts are closed on proof of water flow.

Refrigerant Pressure Relief Valve Venting

⚠ WARNING

Confined Space Hazards!

Failure to follow instructions below could result in death or serious injury. Do not work in confined spaces where refrigerant or other hazardous, toxic or flammable gas may be leaking. Refrigerant or other gases could displace available oxygen to breathe, causing possible asphyxiation or other serious health risks. Some gases may be flammable and or explosive. If a leak in such spaces is detected, evacuate the area immediately and contact the proper rescue or response authority.

Note: Vent pipe size must conform to the ANSI/ASHRAE Standard 15 for vent pipe sizing. All federal, state, and local codes take precedence over any suggestions stated in this manual.

All relief valve venting is the responsibility of the installing contractor.

All RTHD units use evaporator, compressor, and condenser pressure relief valves (Figure 17, p. 35) that must be vented to the outside of the building.

Relief valve connection sizes and locations are shown in the unit submittals. Refer to local codes for relief valve vent line sizing information.

NOTICE:

Equipment Damage!

Do not exceed vent piping code specifications. Failure to comply with specifications may result in capacity reduction, unit damage and/or relief valve damage.

Relief valve discharge setpoints and capacities rates are given in Table 10. Once the relief valve has opened, it will re-close when pressure is reduced to a safe level.

Note: Once opened, relief valves may have tendency to leak and must be replaced.

Figure 17. Relief valve location

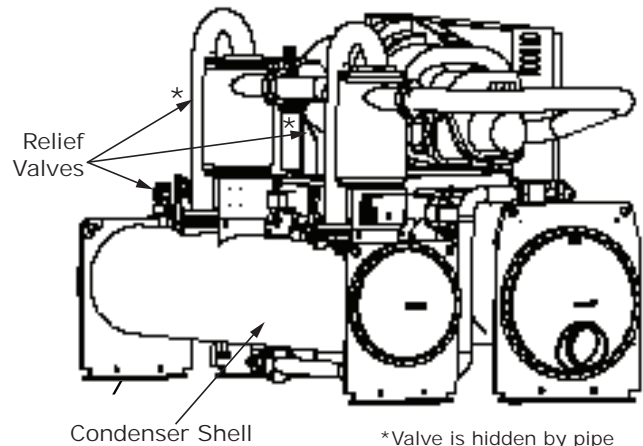
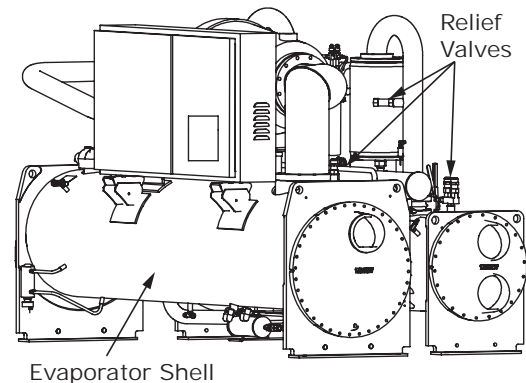

Pressure relief valve discharge capacities will vary with shell diameter and length and also compressor displacement. Discharge venting capacity should be calculated as required by ASHRAE Standard 15-94. Do not adjust relief valve setting in the field.

Table 10. Pressure relief valve data

Valve Location	Discharge Setpoint (psi)	Number of Valves	Rated Capacity per Relief Valve (lba/min.)	Field Conn Pipe Size (NPT)	Factory Shell Side Conn (in)
Evap - B1	200	1	48.0	1	1-5/16 -12
Evap - B2	200	1	48.0	1	1-5/16 -12
Evap -B3	200	1	48.0	1	1-5/16 -12
Evap -C1	200	1	48.0	1	1-5/16 -12
Evap - C2	200	1	48.0	1	1-5/16 -12

Table 10. Pressure relief valve data (continued)

Valve Location	Discharge Setpoint (psi)	Number of Valves	Rated Capacity per Relief Valve (lba/min.)	Field Conn Pipe Size (NPT)	Factory Shell Side Conn (in)
Evap - D1	200	1	48.0	1	1-5/16 -12
Evap - D2	200	1	48.0	1	1-5/16 -12
Evap - D3	200	1	48.0	1	1-5/16 -12
Evap - D4	200	1	48.0	1	1-5/16 -12
Evap - D5	200	1	48.0	1	1-5/16 -12
Evap - D6	200	1	48.0	1	1-5/16 -12
Evap - E1	200	1	48.0	1	1-5/16 -12
Evap - F1	200	1	48.0	1	1-5/16 -12
Evap - F2	200	1	48.0	1	1-5/16 -12
Evap - G1	200	1	78.8	1-1/4	1-5/8 - 12
Evap - G2	200	1	78.8	1-1/4	1-5/8 - 12
Evap - G3	200	1	78.8	1-1/4	1-5/8 - 12
Cond - B1	200	2	48.0	1	1-5/16 -12
Cond - B2	200	2	48.0	1	1-5/16 -12
Cond - D1	200	2	48.0	1	1-5/16 -12
Cond - D2	200	2	48.0	1	1-5/16 -12
Cond - E1	200	2	48.0	1	1-5/16 -12
Cond - E2	200	2	48.0	1	1-5/16 -12
Cond - E3	200	2	48.0	1	1-5/16 -12
Cond - E4	200	2	48.0	1	1-5/16 -12
Cond - E5	200	2	48.0	1	1-5/16 -12
Cond - F1	200	2	48.0	1	1-5/16 -12
Cond - F2	200	2	48.0	1	1-5/16 -12
Cond - F3	200	2	48.0	1	1-5/16 -12
Cond - G1	200	2	48.0	1	1-5/16 -12
Cond - G2	200	2	48.0	1	1-5/16 -12
Cond - G3	200	2	48.0	1	1-5/16 -12
Comp - B1/B2*	200	2	78.8	1-1/4	1-5/8 - 12
Comp - C1/C2*	200	3	78.8	1-1/4	1-5/8 - 12
Comp - D1/D2/D3*	200	3	78.8	1-1/4	1-5/8 - 12
Comp - E3*	200	3	78.8	1-1/4	1-5/8 - 12

* Only used with isolation valve option

Thermal Insulation

All Optimus™ units are available with optional factory installed thermal insulation. If the unit is not factory insulated, install insulation over the areas shaded in [Figure 18, p. 36](#). See [Table 11](#) for types and quantities of insulation required.

Notes:

- *Liquid line filter, refrigerant charging valves, water temperature sensors, drain and vent connections when insulated must remain accessible for service.*
- *Use only water-base latex paint on factory-applied insulation. Failure to do so may result in insulation shrinkage.*
- *Units in environments with higher humidity or very low leaving water temperature may require thicker insulation*

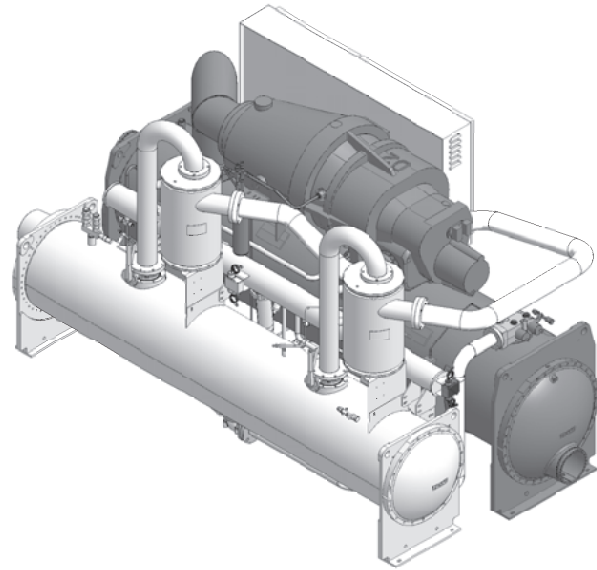
Figure 18. Typical RTHD insulation requirement

Table 11. Recommended insulation types

Location	Type	Sq. Feet
Evaporator	3/4" wall	90
Compressor	3/4" wall	25
All components and piping on low side of system (gas pump, return oil line, filter from pump)	3/4" wall	160

Freeze Protection

For unit operation in a low temperature environment, adequate protection measures must be taken against freezing. Adjusted settings and recommended ethylene

glycol solution strengths are contained in [Table 12](#) as follows:

Table 12. Low refrigerant temperature, ethylene glycol, and freeze protection settings

Chilled Water Setpt (°F) ^(a)	Leaving Wtr Temp Cutout (°F)	DDE, EDE, CBC ^(b)			DFF, EFF, CDE, BCD, BBB, CFF ^(b)			DGG, EGG, CEF ^(b)		
		Low Rfght Temp Cutout ^(c) (°F)	Rec % Ethylene Glycol	Solution Freeze Point (°F)	Low Rfght Temp Cutout ^(c) (°F)	Rec % Ethylene Glycol	Solution Freeze Point (°F)	Low Rfght Temp Cutout ^(c) (°F)	Rec % Ethylene Glycol	Solution Freeze Point (°F)
40	34	28.6	0	32.0	28.6	0	32.0	28.6	0	32.0
39	33	27.2	2	30.6	27.6	1	31.3	27.9	0	32.0
38	32	25.7	4	29.1	26.5	3	30.1	27.2	2	31.1
37	31	24.2	6	27.6	25.4	5	28.9	26.5	3	30.2
36	30	22.7	8	26.1	24.2	6	27.7	25.7	4	29.3
35	29	21.1	11	24.5	23.0	8	26.4	24.9	6	28.3
34	28	20.2	12	23.6	22.1	10	25.5	24.0	7	27.4
33	27	19.2	13	22.6	21.1	11	24.5	23.0	8	26.4
32	26	18.1	15	21.5	20.1	12	23.5	22.0	10	25.4
31	25	17.0	16	20.4	18.8	14	22.2	20.6	12	24.0
30	24	15.9	17	19.3	17.6	15	21.0	19.3	13	22.7
29	23	14.8	18	18.2	16.6	16	20.0	18.4	14	21.8
28	22	13.6	20	17.0	15.5	17	18.9	17.4	15	20.8
27	21	12.4	21	15.8	14.4	18	17.8	16.4	16	19.8
26	20	11.2	22	14.6	13.3	20	16.7	15.4	17	18.8
25	19	9.9	23	13.3	12.1	21	15.5	14.3	19	17.7
24	18	8.6	24	12.0	10.9	22	14.3	13.2	20	16.6
23	17	7.3	25	10.7	9.7	23	13.1	12.1	21	15.5
22	16	5.9	26	9.3	8.4	24	11.8	10.9	22	14.3
21	15	4.5	27	7.9	7.1	25	10.5	9.7	23	13.1
20	14	3.1	28	6.5	5.8	26	9.2	8.5	24	11.9
19	13	1.6	30	5.0	4.4	27	7.8	7.3	25	10.7
18	12	0.1	31	3.5	3.1	29	6.5	6.0	27	9.4
17	11	-1.4	32	2.0	1.6	30	5.0	4.7	28	8.1
16	10	-2.9	33	0.5	0.2	31	3.6	3.3	29	6.7
15	9	-4.5	33	-1.1	-1.3	32	2.1	2.0	30	5.4
14	8	N/A	34	-2.8	-2.8	33	0.6	0.6	31	4.0
13	7	N/A	35	-4.4	-4.3	34	-0.9	-0.8	32	2.6
12	6	N/A	36	-6.1	N/A	34	-2.5	-2.3	33	1.1
11	5	N/A	37	-7.8	N/A	35	-4.1	-3.8	34	-0.4
10	4	N/A	38	-9.6	N/A	36	-5.7	-5.3	34	-1.9

(a) Column "Chilled Water Setpoint" becomes "Actual Leaving Solution Temperature" for ice-making.

(b) See unit model number digits 6, 14, 21

(c) "N/A" means chiller is not to be applied at leaving evaporator water temperatures, which results in the LRTC setting below those shown in the table.

Example For Ice Making:

Chilled Water Setpoint (std. comfort cooling) = 45°F

Full Load Delta T (across evaporator)= 6°F

Ice Termination Setpoint (entering water temp.) = 26°F

Actual Leaving Solution Temperature = 26 - 6 = 20°F



Installation Electrical

General Recommendations

As you review this manual, keep in mind that:

- All field-installed wiring must conform to National Electric Code (NEC) guidelines, and any applicable state and local codes. Be sure to satisfy proper equipment grounding requirements per NEC.
- Compressor motor and unit electrical data is listed on the chiller nameplate.
- All field-installed wiring must be checked for proper terminations, and for possible shorts or grounds.
- For proper electrical component operation, do not locate the unit in areas exposed to dust, dirt, corrosive fumes, or excessive humidity. If any of these conditions exist, corrective action must be taken.

Notes:

- Always refer to wiring diagrams shipped with chiller or unit submittal for specific electrical schematic and connection information.
- All conduit must be long enough to allow compressor and starter removal.

⚠ WARNING

Proper Field Wiring and Grounding Required!

Failure to follow code could result in death or serious injury. All field wiring MUST be performed by qualified personnel. Improperly installed and grounded field wiring poses FIRE and ELECTROCUTION hazards. To avoid these hazards, you MUST follow requirements for field wiring installation and grounding as described in NEC and your local/state electrical codes.

⚠ WARNING

Hazardous Voltage w/Capacitors!

Failure to disconnect power and discharge capacitors before servicing could result in death or serious injury. Disconnect all electric power, including remote disconnects before servicing. Follow proper lockout/tagout procedures to ensure the power cannot be inadvertently energized. For variable frequency drives or other energy storing components provided by Trane or others, refer to the appropriate manufacturer's literature for allowable waiting periods for discharge of capacitors. Verify with an appropriate voltmeter that all capacitors have discharged.

For additional information regarding the safe discharge of capacitors, see PROD-SVB06A-EN.

Important: Do not allow conduit to interfere with other components, structural members or equipment. Control voltage (115V) wiring in conduit must be separate from conduit carrying low voltage (<30V) wiring. To prevent control malfunctions, do not run low voltage wiring (<30 V) in conduit with conductors carrying more than 30 volts.

Electrical Data

Standard Units with Wye-Delta Starter

See "Electrical Data Table Information," p. 39. Electrical component sizing should be based on actual jobsite operating conditions. This factor can be obtained through the use of TOPSS™.

Table 13. Compressor motor electrical data (60 Hz) — standard units (wye-delta starter)

Compressor Code ^(a)	Voltage ^(b)	RLA @			
		Max kW	Max kW ^(c)	LRA (Wye)	LRA (Delta)
B1, B2	200	174	557	970	3103
	230	174	484	818	2617
	380	174	291	488	1561
	460	174	241	400	1280
	575	174	193	329	1053
C1, C2	200	249	812	1173	3634
	230	249	698	936	2901
	380	249	421	558	1727
	460	249	349	469	1453
	575	249	279	375	1162
D1, D2	200	329	1047	1690	5477
	230	329	918	1532	4966
	380	329	549	850	2755
	460	329	455	730	2366
	575	329	367	612	1984

(a) Unit model number digits 6 & 7.

(b) Voltage utilization ranges: 200V (180-220)m 230V (205-254), 380V (342-418), 460V (414-506), 575V (516-633).

(c) The RLA @ Max kW is based on the performance of the motor developing full rated horsepower.

Table 14. Compressor motor electrical data (50 Hz) – standard units (wye-delta starter)

Compressor Code ^(a)	Voltage ^(b)	Max kW	RLA @		LRA (Delta)
			Max kW ^(c)	(Wye)	
B1, B2	380	139	233	391	1229
	400	145	233	412	1296
	415	148	233	428	1348
C1, C2	380	201	349	456	1414
	400	209	349	480	1488
	415	213	349	498	1544
D1, D2, D3	380	271	455	711	2303
	400	280	455	748	2424
	415	284	455	776	2515
E3	380	288	488	711	2303
	400	301	488	748	2424
	415	306	488	776	2515

(a) Unit model number digits 6 & 7.

(b) Voltage utilization ranges: 380V (342-418), 400V (360-440), 415V (374-457).

(c) The RLA @ Max kW is based on the performance of the motor developing full rated horsepower.

Electrical Data Table Information

Compressor motor electrical data is provided in [Table 13, p. 38](#) and [Table 14](#) for each compressor size. Rated load amperes (RLA), locked rotor wye amperes (LRA) and expected inrush for the Wye-delta configurations are shown.

Although the terms “LRA” and “expected inrush” are often used interchangeably, the distinction applied here is that LRA is the rated inrush for the motor, but expected inrush is that allowed by the starter, based on the specific configuration. Selecting starters in the Wye-delta configuration lowers expected inrush vs. the Delta (or “across-the-line”) configuration.

The RLA is based on the motor’s performance when reaching full rated horsepower. The kW rating of the motor will equal or exceed the kW requirement indicated by the TOPSS™ selection program at design conditions. If motor kW draw at design conditions is less than the kW rating of the motor, the RLA at design conditions is determined by multiplying the motor RLA (at the desired voltage) by this ratio: design kW/ motor kW rating. This calculation is performed within the computer selection program, making RLA available as part of the design predictions. Predicted values include power factor variation from point to point.

Optimus™ chillers are designed to operate satisfactorily over a utilization range of ±10 percent of the standard design voltages: (a) 200V, 230V, 380V, 460V, and 575V for 60 Hertz, 3- phase, and (b) 380V, 400V, 415V for 50 Hertz, 3-phase.

Units with AFD Option

Table 15. Electrical data – units with AFD

Voltage	Applied Range (Model Number digits 56-58)	Estimated Power Loss (W)
575V 60 Hz	0 - 126	1739
	127 - 150	2099
	151 - 185	2646
	186 - 234	3071
	235 - 279	3719
	280 - 316	4460
460V 60 Hz	317 - 366	5023
	0 - 176	2257
	177 - 223	2719
	224 - 280	3622
	281 - 335	3561
	336 - 411	4558
380V 60 Hz	412 - 455	5703
	0 - 197	2555
	198 - 241	2949
	242 - 292	3764
	293 - 367	4109
	368 - 446	5129
380V 50 Hz	447 - 549	6663
	0 - 197	2555
	198 - 241	2949
	242 - 292	3764
	293 - 367	4109
	368 - 446	5129
400V 50 Hz	447 - 549	6663
	400V 50 Hz	
	415V 50 Hz	

Note: AFD input amps are shown in the RLA field of the unit nameplate.

Installer-Supplied Components

Customer wiring interface connections are shown in the electrical schematics and connection diagrams that are shipped with the unit. The installer must provide the following components if not ordered with the unit:

- Power supply wiring (in conduit) for all field-wired connections.
- All control (interconnecting) wiring (in conduit) for field supplied devices.
- Fused-disconnect switches or circuit breakers.

Power Supply Wiring

⚠ WARNING

Proper Field Wiring and Grounding Required!

Failure to follow code could result in death or serious injury. All field wiring **MUST** be performed by qualified personnel. Improperly installed and grounded field wiring poses **FIRE** and **ELECTROCUTION** hazards. To avoid these hazards, you **MUST** follow requirements for field wiring installation and grounding as described in NEC and your local/state electrical codes.

⚠ WARNING

Hazardous Voltage w/Capacitors!

Failure to disconnect power and discharge capacitors before servicing could result in death or serious injury. Disconnect all electric power, including remote disconnects before servicing. Follow proper lockout/tagout procedures to ensure the power cannot be inadvertently energized. For variable frequency drives or other energy storing components provided by Trane or others, refer to the appropriate manufacturer's literature for allowable waiting periods for discharge of capacitors. Verify with an appropriate voltmeter that all capacitors have discharged.

For additional information regarding the safe discharge of capacitors, see PROD-SVB06A-EN.

All power supply wiring must be sized and selected accordingly by the project engineer in accordance with NEC Table 310-16.

All wiring must comply with local codes and the National Electrical Code. The installing (or electrical) contractor must provide and install the system interconnecting wiring, as well as the power supply wiring. It must be properly sized and equipped with the appropriate fused disconnect switches.

The type and installation location(s) of the fused disconnects must comply with all applicable codes.

NOTICE:

Use Copper Conductors Only!

Failure to use copper conductors could result in equipment damage as unit terminals are not designed to accept other types of conductors.

See [Figure 19](#) for electrical installation panel locations.

Figure 19. Electrical Installation

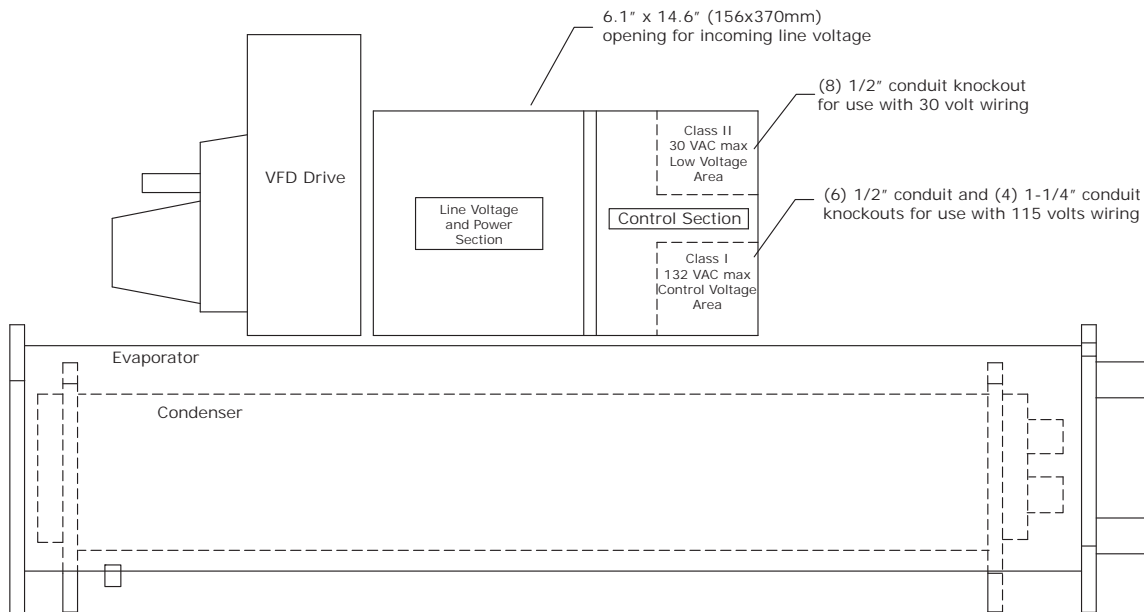

Water Pump Power Supply

Provide power supply wiring with fused disconnect for both the chilled water and condenser water pumps.

Compressor Motor Phase Sequencing

Always verify that proper rotation of the compressor is established before the machine is started. Proper motor rotation requires confirmation of the electrical phase sequence of the power supply. The motor is internally connected for clockwise rotation with incoming power supply phased A, B, C.

Units with Optional AFD.

NOTICE:

Equipment Damage!

- Do not change AFD phase rotation to counterclockwise.
- Do not enable phase reversal protection.

Changing default clockwise phase rotation or enabling phase reversal protection could prevent proper chiller operation or cause equipment damage.

AFD must be set with phase rotation clockwise (default from factory), and phase reversal protection DISABLED.

All Units. To confirm the correct phase sequence (ABC), use a Model 45 Associated Research Phase indicator or equivalent.

Voltages generated in each phase of a polyphase alternator or circuit are called phase voltages. In a three-phase circuit, three sine wave voltages are generated, differing in phase by 120 electrical degrees. The order in which the three voltages of a three-phase system succeed one another is called phase sequence or phase rotation. This is determined by the direction of rotation of the alternator. When rotation is clockwise, phase sequence is usually called "ABC," when counterclockwise, "CBA."

This direction may be reversed outside the alternator by interchanging any two of the line wires. It is this possible interchange of wiring that makes a phase sequence indicator necessary if the operator is to quickly determine the phase rotation of the motor.

Correcting Improper Electrical Phase Sequence.

Proper compressor motor electrical phasing can be quickly determined and corrected before starting the unit. If using an Associated Research Model 45 Phase Sequence Indicator, follow this procedure:

1. Press the STOP button to insure the unit will not attempt to start the compressor.
2. Open the electrical disconnect or circuit protection switch that provides line power to the line power terminal block in the control panel (or to the unit-mounted disconnect).

3. Connect the phase sequence indicator leads to the line power terminal block (or the unit mounted disconnect) as follows:

Phase Seq. Lead	1TB1 Terminal
Black (Phase A)	L1
Red (Phase B)	L2
Yellow (Phase C)	L3

4. Turn power on by closing the unit supply power disconnect switch.
5. Read the phase sequence on the indicator. The "ABC" indicator on the face of the phase indicator will glow if phase is "ABC"

⚠ WARNING

Hazardous Voltage w/Capacitors!

Failure to disconnect power and discharge capacitors before servicing could result in death or serious injury. Disconnect all electric power, including remote disconnects before servicing. Follow proper lockout/tagout procedures to ensure the power cannot be inadvertently energized. For variable frequency drives or other energy storing components provided by Trane or others, refer to the appropriate manufacturer's literature for allowable waiting periods for discharge of capacitors. Verify with an appropriate voltmeter that all capacitors have discharged.

For additional information regarding the safe discharge of capacitors, see PROD-SVB06A-EN.

6. If "CBA" indicator glows instead, open unit main power disconnect and switch two line leads on the line power terminal block (or the unit mounted disconnect). Re-close main power disconnect and recheck phasing.
7. Reopen the unit disconnect and disconnect the phase indicator.

Electrical Connections

Proper starter/control panel line-side lug sizes are specified on the unit submittals. These lug sizes must be compatible with conductor sizes specified by the electrical engineer or contractor.

For recommended field connection lug sizes (RTHD starters) see unit submittal.

Circuit Breakers and Non-Fused Disconnect Switches (Factory Installed Option)

Units that are ordered with factory installed circuit breakers or non-fused disconnect switches ship with the handle in the control panel. The handle must be installed prior to starting the unit.

The operating mechanism is already pre-installed on the Disconnect/ Circuit Breaker frame.

The hole locations and shafts lengths have already been cut, and the shaft already installed.

⚠ WARNING

Hazardous Voltage w/Capacitors!

Failure to disconnect power and discharge capacitors before servicing could result in death or serious injury. Disconnect all electric power, including remote disconnects before servicing. Follow proper lockout/tagout procedures to ensure the power cannot be inadvertently energized. For variable frequency drives or other energy storing components provided by Trane or others, refer to the appropriate manufacturer's literature for allowable waiting periods for discharge of capacitors. Verify with an appropriate voltmeter that all capacitors have discharged.

For additional information regarding the safe discharge of capacitors, see PROD-SVB06A-EN.

1. Attach the handle and gasket to the enclosure door and secure with the four bolts, lock washers and nut as shown in Figure 20. Tighten to 75 in-Lbs.

Note: There is an additional Lexan spacer on the handle, not shown in the Figure 20. Do not remove.

Figure 20. Handle on door

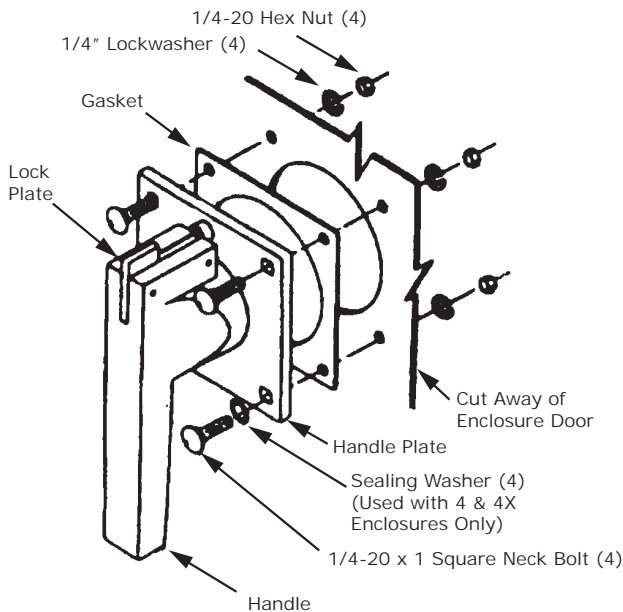

2. Check that when the enclosure door is closed, the handle interlocks with the shaft in all handle positions except RESET/OPEN. To open the enclosure door when the breaker is in the ON position, rotate the screw slot on the handle plate counter-clockwise. Verify operation.

⚠ WARNING

Hazardous Voltage w/Capacitors!

Failure to disconnect power and discharge capacitors before servicing could result in death or serious injury. Disconnect all electric power, including remote disconnects before servicing. Follow proper lockout/tagout procedures to ensure the power cannot be inadvertently energized. For variable frequency drives or other energy storing components provided by Trane or others, refer to the appropriate manufacturer's literature for allowable waiting periods for discharge of capacitors. Verify with an appropriate voltmeter that all capacitors have discharged.

For additional information regarding the safe discharge of capacitors, see PROD-SVB06A-EN.

Important: WHEN EVACUATING THE CHILLER'S REFRIGERANT SYSTEM, ALWAYS HAVE THE MAIN POWER DISCONNECT/CIRCUIT BREAKER OPENED. Even when the compressor is not running, voltage is present at the compressor motor terminals, providing the potential for current to flow through a low impedance path.

NOTICE:

Equipment Damage!

When removing refrigerant for the chiller, both the condenser and chilled water pump must be operating to avoid freeze up.

NOTICE:

Motor Damage!

Fully disconnect all power sources before pumpdown or evacuation procedures and ensure disconnects cannot be closed while chiller is in a vacuum. Failure to do so could cause motor damage.

As the chiller is evacuated below atmospheric pressure, the dielectric strength (resistance to arcing) of the gaseous atmosphere is significantly reduced. Because the SCRs are connected "inside the delta," three of the motor terminals are connected directly to the line voltage. An "arc over" can occur between motor terminals under conditions seen in the evacuation process. If this occurs the circuit breaker (or other external protective devices) will trip in response to high fault currents, and motor damage may also occur. To avoid motor damage, verify chiller **fully disconnected from all power sources before beginning pumpdown or evacuation procedures**, and use proper lockout/tagout procedures to make sure the disconnect cannot be accidentally closed while the chiller is in a vacuum.

Module Connections for Interconnecting Wiring

All connectors can be unplugged or the wires can be removed from the screw assembly. If an entire plug is removed, make sure the plug and the associated jack are marked for proper location identification during reinstallation.

NOTICE:

Equipment Failure!

Plugs and jacks must be clearly marked before disconnecting, because specific plugs will fit into other jacks. Possible damage to equipment may occur if the plugs are reversed with the jacks.

Interconnecting Wiring (Field Wiring Required)

Important: Do not turn chiller on or off using the chilled water pump interlocks.

When making field connections, refer to the appropriate field layout, wiring, schematics and controls diagrams that ship with the unit. The diagrams in this manual are typical only and may not match the unit.

Whenever a contact closure (binary output) is referenced, the electrical rating is:

At 120 VAC	7.2 amp resistive
	2.88 amp pilot duty
	1/3 hp, 7.2 FLA, 43.2 LRA
At 240 VAC	5.0 amp resistive
	2.0 amp pilot duty
	1/3 hp, 3.6 FLA, 21.6 LRA

Whenever a dry contact input (binary input) is referenced, the electrical rating is 24VDC, 12 mA.

Whenever a control voltage contact input (binary input) is referenced, the electrical rating is 120 VAC, 5mA.

Note: Connections denoted with an asterisk require the user to provide an external source of power. The 115V control power transformer is not sized for additional load.

Chilled Water Pump Control

UC800 has a evaporator water pump output relay that closes when the chiller is given a signal to go into the Auto mode of operation from any source. The contact is opened to turn off the pump in the event of most machine level diagnostics to prevent the build up of pump heat. To protect against the build-up of pump heat for those diagnostics that do not stop and/or start the pump and to protect against the condition of a bad flow switch, the pump shall always be stopped when the evaporator pressure is seen to be close to the Low Side Evaporator Pressure relief valve setting.

Chilled Water Flow Interlock

UC800 has an input that will accept a contact closure from a proof-of-flow device such as a flow switch. The flow switch is to be wired in series with the chilled water pump starter's auxiliary contacts. When this input does not prove flow within 20 minutes relative to transition from Stop to Auto modes of the chiller, or if the flow is lost while the chiller is in the Auto mode of operation, the chiller will be inhibited from running by a non-latching diagnostic. The flow switch input shall be filtered to allow for momentary openings and closings of the switch due to turbulent water flow. This is accomplished with a 6 seconds filtering time. The sensing voltage for the condenser water flow switch is 115/240 VAC.

Important: DO NOT cycle the chiller through starting and stopping the chilled water pump. This could cause the compressor to shut down fully loaded. Use the external stop/start input to cycle the chiller.

Condenser Water Pump Control

UC800 provides a contact closure output to start and stop the condenser water pump. If condenser pumps are arranged in a bank with a common header, the output can be used to control an isolation valve and/or signal another device that an additional pump is required.

Condenser Water Pump Prestart time has been added to help with cold condenser water problems. In very cold outdoor ambients, the cooling towers sump cold water would reach the chiller some time after the low system differential pressure protection had run through its ignore time, and result in an immediate shutdown and latching diagnostic. By simply starting the pump earlier, and allowing mixing of the warmer indoor loop with the cooling tower's sump, this problem can be avoided.

Condenser Water Flow Interlock

The UC800 shall accept an isolated contact closure input from a customer installed proof-of-flow device such as a flow switch and customer provided pump starter auxiliary contact for interlocking with condenser water flow. The input shall be filtered to allow momentary openings and closings of the switch due to turbulent water flow, etc. This shall be accomplished with a 6 seconds filtering time. The sensing voltage for the condenser water flow switch is 115/240 VAC.

On a call for cooling after the restart inhibit timer has timed out, the UC800 shall energize the condenser water pump relay and then check the condenser water flow switch and pump starter interlock input for flow confirmation. Startup of the compressor will not be allowed until flow has proven.

If flow is not initially established within 1200 seconds (20 minutes) of the condenser pump relay energizing, an automatically resetting diagnostic "Condenser Water Flow Overdue" shall be generated which terminates the prestart mode and de-energizes the condenser water



Installation Electrical

pump relay. This diagnostic is automatically reset if flow is established at any later time.

Note: *This diagnostic would never automatically reset if UC800 was in control of the condenser pump through its condenser pump relay since it is commanded off at the time of the diagnostic. It could however reset and allow normal chiller operation if the pump was controlled from some external source.*

Chilled Water Reset (CWR)

The controller will reset the chilled water temperature setpoint based on either return water temperature, or outdoor air temperature. The Return Reset option is standard, Outdoor Reset is optional.

The following is selectable:

- **RESET TYPE** Setpoint.
This can be set to: DISABLE, CONSTANT, RETURN or OUTSIDE AIR. The MP shall not permit more than one type of reset to be selected.
- **RESET RATIO** Setpoints.
For outdoor air temp. reset, both positive and negative reset ratios will be allowed.
- **START RESET** Setpoints.
- **MAXIMUM RESET** Setpoints.
The maximum resets shall be with respect to the chilled water setpoint.

When the chiller is running, if any type of CWR is enabled, the controller will step the CWS toward the desired CWS' (based on the below equations and setup parameters) at a rate of 1 degree F every 5 minutes until the Active CWS equals the desired CWS'. When the chiller is not running the CWS will be fully reset immediately (within one minute). The chiller will then start at the Differential to Start value above a fully reset CWS or CWS' for Outdoor, Return, and Constant Return Reset.

Equations for calculating CWR

Equation used to get Degrees of Reset:

Outdoor Air:

Degrees of Reset =
Reset Ratio * (Start Reset - TOD)

Return Reset:

Degrees of Reset =
Reset Ratio * (Start Reset - (TWE - TWL))

Constant Return:

Degrees of Reset =
100% * (Design Delta Temp - (TWE - TWL))

To obtain Active CWS from Degrees of Reset:

Active CWS = Degrees of Reset + Previous CWS

Note: *Previous CWS can either be Front Panel, BAS, or External*

Reset Ratio calculation:

The Reset Ratio on the User Interface is displayed as a percentage. To use it in the above equation it must be converted to its decimal form.

Reset Ratio percent / 100 = Reset Ratio decimal

Example of converting Reset Ratio:

If the Reset Ratio displayed on the User Interface is 50% then use (50/100) = 0.5 in the equation.

Abbreviations used in equations:

- TOD = Outdoor Air Temp
- TWE = Evap Entering Water Temp
- TWL = Evap Leaving Water Temp

Programmable Relays (Alarm and Status) - Optional

UC800 provides a flexible alarm or chiller status indication to a remote location through a hard wired interface to a dry contact closure. Four relays are available for this function, and they are provided (generally with a Quad Relay Output LLID) as part of the Alarm Relay Output Option.

The events/states that can be assigned to the programmable relays are listed in the following table.

Table 16. Chiller events/status descriptions

Event/State	Description
Alarm - Latching	This output is true whenever there is any active diagnostic that requires a manual reset to clear, that affects the Chiller, the Circuit, or any of the Compressors on a circuit. This classification does not include informational diagnostics.
Alarm - Auto Reset	This output is true whenever there is any active diagnostic that could automatically clear, that affects the Chiller, the Circuit, or any of the Compressors on a circuit. This classification does not include informational diagnostics. If all of the auto resetting diagnostics were to clear, this output would return to a false condition.
Alarm	This output is true whenever there is any diagnostic effecting any component, whether latching or automatically clearing. This classification does not include informational diagnostics.
Warning	This output is true whenever there is any informational diagnostic affecting any component, whether latching or automatically clearing.
Chiller Limit Mode	This output is true whenever the chiller has been running in one of the Unloading types of limit modes (Condenser, Evaporator, Current Limit or Phase Imbalance Limit) continuously for the last 20 minutes. A given limit or overlapping of different limits must be in effect continuously for 20 minutes prior to the output becoming true. It will become false, if no Unload limits are present for 1 minute. The filter prevents short duration or transient repetitive limits from indicating. The chiller is considered to be in a limit mode for the purposes of front panel display and annunciation, only if it is fully inhibiting loading by virtue of being in either the "hold" or "forced unload" regions of the limit control, excluding the "limited loading region".

Table 16. Chiller events/status descriptions (continued)

Event/State	Description
Compressor Running	The output is true whenever any compressors are started or running on the chiller and false when no compressors are either starting or running on the chiller. This status may or may not reflect the true status of the compressor in Service Pumpdown if such a mode exists for a particular chiller.
Chiller Head Pressure Relief Request Relay	This relay output is energized anytime the chiller is running in one of the following modes: Ice Making Mode or Condenser Pressure Limit Control Mode continuously for the duration specified by the Chiller Head Relief Relay Filter Time. The Chiller Head Relief Relay Filter Time is a service setpoint. The relay output is de-energized anytime the chiller exits all above modes continuously for the duration specified by the same Chiller Head Relief Relay Filter Time.

The UC800 Service Tool (Tracer[®] TU) is used to install and assign any of the above listed events or status to each of the four relays provided with this option.

The default assignments for the four available relays are listed below.

Table 17 Programmable relays

LLID Name	LLID Software Relay		Output Designation Name	Default
	Relay	Output		
Operating Status Programmable Relays	Relay 0	Status Relay 4, J2-1,2,3	Head Pressure Relief Request	
	Relay 1	Status Relay 3, J2-4,5,6	Chiller Limit Mode Relay	
	Relay 2	Status Relay 2, J2-7,8,9	Chiller Alarm Relay (latching or nonlatching)	
	Relay 3	Status Relay 1, J2-10,11,12	Compressor Running Relay	

Emergency Stop

The UC800 provides auxiliary control for a customer specified/installed latching trip out. When this customer-furnished remote contact is provided, the chiller will run normally when the contact is closed. When the contact opens, the unit will trip off on a manually resettable diagnostic. This condition requires manual reset at the chiller switch on the front of the control panel.

External Auto/Stop

If the unit requires the external Auto/Stop function, the installer must provide leads from the remote contacts to the proper terminals of the LLID on the control panel.

The chiller will run normally when the contacts are closed. When the contact opens, the compressor(s), if operating, will go to the RUN:UNLOAD operating mode and cycle off. Unit operation will be inhibited. Re-closure of the contacts will permit the unit to automatically return to normal operation.

Note: A “panic” stop (similar to “emergency” stop) can be manually commanded by pressing the STOP button twice in a row, the chiller will immediately shut down, but without creating a latching diagnostic.

Soft Loading

Soft loading will prevent the chiller from going to full capacity during the pull-down period.

The UC800 control system has two soft loading algorithms running all of the time. They are capacity control soft loading and current limit soft loading. These algorithms introduce the use of a Filtered Chilled Water Setpoint and a Filtered Current Limit Setpoint. After the compressor has been started, the starting point of the filtered chilled water setpoint is initialized to the value of the Evap Leaving Water Temperature. The filtered current limit setpoint is initialized to the value of the Current Limit Softload Starting Percent. These filtered setpoints allow for a stable pull-down that is user adjustable in duration. They also eliminate sudden transients due to setpoint changes during normal chiller operation.

Three settings are used to describe the behavior of soft loading. The setup for softloading can be done using Tracer[®] TU.

- **Capacity Control Softload Time:** This setting controls the time constant of the Filtered Chilled Water Setpoint. It is settable between 0 and 120 min.
- **Current Limit Control Softload Time:** This Setting controls the time constant of the Filtered Current Limit Setpoint. It is settable between 0 and 120 minutes.
- **Current Limit Softload Starting Percent:** This setting controls the starting point of the Filtered Current Limit Setpoint. It is adjustable from 40 for RTHD to 100 percent RLA.

External Base Loading - Optional

Primarily for process control requirements, base loading provides for immediate start and loading of a chiller up to an externally or remotely adjustable current limit setpoint without regard to differential to start or stop, or to leaving water temperature control. This allows the flexibility to prestart or preload a chiller in anticipation of a large load application. It also allows you to keep a chiller on line between processes when leaving water temperature control would normally cycle the unit.

When the base loading option is installed through TD7 it will be controllable through TD7/Tracer[®] TU, External Hardware Interface or Tracer (if Tracer is installed). Order for precedence for all setpoints, TD7/Tracer[®] TU, then External then Tracer from lowest to highest priority. If one of the higher priority setpoints drops out due to a bad sensor or communication loss then base loading shall go to the next lowest priority of command and setpoint. The command settings and control setpoints associated with base loading are explained below.

Base Loading Control Setpoint

This setpoint has three possible sources, an External Analog Input, TD7/Tracer® TU or Tracer®.

- TD7/Tracer® TU Base Loading Control Setpoint
- The range is 40 - 100% Compressor Load (Max %RLA). The default is 50%.
- Tracer Base Loading Control Setpoint
- The range is 40 - 100% Compressor Load (Max %RLA). The default is 50%.
- External Base Loading Setpoint

This is an Analog Input that sets the base loading setpoint. This signal can be controlled by either a 2-10Vdc or 4-20mA Signal based on configuration information. The equations show the relationship between input and percent compressor load:

If the input is configured as a 4 - 20 mA:
 $\% \text{ Load} = 3.75 * (\text{mA Input}) + 25$

If the input is configured as a 2 - 10 Vdc:
 $\% \text{ Load} = 7.5 * (\text{Vdc Input}) + 25$

Ice Making Contact - Optional

UC800 accepts a contact closure input to initiate Ice Building. When in the ice building mode, the compressor will be fully loaded (not given a low setpoint) and will continue to operate until the ice contacts open or the return water temperature reaches the Ice Termination Setpoint. If terminated on return setpoint, UC800 will not allow chiller to restart until ice making contact is opened.

Ice Machine Control - Optional

UC800 provides an output contact closure that can be used as a signal to the system that ice building is in operation. This relay will be closed when ice building is in progress and open when ice building has been terminated by either UC800 or remote interlock. It is used to signal the system changes required to convert to and from ice making.

External Chilled Water Setpoint - Optional

UC800 will accept either a 2-10 VDC or a 4-20 mA input (J9-4, J9-5) signal, to adjust chilled water setpoint remotely.

External Current Limit Setpoint - Optional

UC800 will accept either a 2-10VDC or a 4-20mA input (J7-11, J7-12) signal to adjust the current limit setpoint from a remote location.

Percent Condenser Pressure Output - Optional

UC800 provides a 2-10 VDC analog output to indicate percent High Pressure Cutout (HPC) condenser pressure.
 $\text{Percent HPC} = (\text{Condenser Pressure/High Pressure Cutout Setpoint}) * 100$

Compressor Percent RLA Output - Optional

UC800 provides a 2-10 Vdc analog output to indicate %RLA of compressor starter average phase current. The values of 2 to 10 Vdc correspond to 0 to 120% RLA.

AFD Drive (Optional)

Trane TR200 drive is an electronic motor controller that converts AC mains input into a variable AC waveform output. The frequency and voltage of the output are regulated to control the motor speed or torque.

TR200 drive includes the following features:

- Soft start to minimize inrush current
- Improved harmonic mitigation with DC link reactor
- Integrated power fuse
- Graphical LCD keypad
- Unit Mounted with factory pre-wiring
- 'Trane Drive Utility' for configuration and tracking

See Service Manual BAS-SVM01A-EN for more information.

AFD Drive Installation

The AFD drive is manufactured with a jumper installed between terminal 12 (+24Vdc source) and terminal 37 (Safe Stop digital input). This jumper must be removed prior to unit operation. See [Figure 21](#) for view of jumper as it would be installed on drive from manufacturer.

NOTICE:

Equipment Damage!
Verify/remove jumper between AFD terminals 12 and 37 before unit operation. Failure to remove jumper could cause equipment damage.

Figure 21. AFD jumper



Important:

- For factory provided AFD units, verify jumper has been removed.
- For field installed drives, remove jumper shown in [Figure 21](#).

AFD Drive Programming

NOTICE:

Equipment Damage!

- Do not change AFD phase rotation to counterclockwise.
- Do not enable phase reversal protection.

Changing default clockwise phase rotation or enabling phase reversal protection could prevent proper chiller operation or cause equipment damage.

Field replacement drives must be programmed via the keypad interface. Program non-compressor specific parameters first in sequential order ([Table 18](#)), followed by compressor specific parameters (see [Table 19](#)) in sequential order.

Table 18. Non-compressor specific parameter settings

ID	Description	Setting
0-03	Region Settings	North American
0-20	Display Line 1.1 Small	DC Link Voltage
0-22	Display Line 1.3	Heatsink Temp.
0-24	Display Line 3 Large	Analog Input 53
0-40	[Hand on] Key on LCP	Disabled
0-41	[Off] Key on LCP	Disabled
0-60	Main Menu Password	999
0-61	Access to Main Menu w/o Password	Read Only
1-03	Torque Characteristics	Compressor Torque
1-71	Start Delay	0s
1-73	Flying Start	Disabled
1-78	Compressor Start Max Speed [Hz]	20Hz
1-79	Compressor Start Max Time to Trip	10s
1-87	Trip Speed Low [Hz]	25Hz
3-02	Min Reference	30Hz
3-41	Ramp 1 Ramp up Time	10s
3-42	Ramp 1 Ramp Down Time	10s
3-82	Starting Ramp Up Time	5s
4-10	Motor Speed Direction	Clockwise
4-12	Motor Speed Low Limit [Hz]	30Hz
4-18	Current Limit	Max
5-02	Terminal 29 Mode	Output
5-12	Terminal 27 Digital Input	Coast Inverse
5-31	Terminal 29 Digital Output	Alarm
5-40	Function Relay 1	No Operation
6-10	Terminal 53 Low Voltage	2V
6-14	Terminal 53 Low Ref./Feedb. Value	30Hz
6-50	Terminal 42 Output	Power 4-20mA
14-00	Switching Pattern	SFAVM
14-03	Overmodulation	Off
14-10	Mains Failure	[4] Kinetic Back-Up
14-12	Function at Mains Imbalance	Derate
14-21	Automatic Restart Time	8s
14-50	RFI Filter	Off
14-51	DC Link Compensation	On
14-60	Function at Over Temperature	Derate
14-61	Function at Inverter Overload	Derate
14-62	Inv. Overload Derate Current	75%



Installation Electrical

Table 19. Compressor-specific parameter settings^(a)

Parameters ID Description	B1/B2 Motor Frame				C1/C2 Motor Frame				D1/D2/D3/E3 Motor Frame				E3 Motor Frame
	460/ 60	400/ 50	380/ 60	575/ 60	460/ 60	400/ 50	380/ 60	575/ 60	460/ 60	400/ 50	380/ 60	575/ 60	400/ 50
1-21 Motor Power (hp)	233	194	233	233	334	280	334	334	441	375	441	441	403
1-22 Motor Voltage (V)	460	400	380	575	460	400	380	575	460	400	380	575	400
1-23 Motor Frequency (Hz)	60	50	60	60	60	50	60	60	60	50	60	60	50
1-24 Motor Current (A)	241	233	291	193	349	349	421	279	455	455	549	367	488
1-25 Motor Nominal Speed (rpm)	3512	2921	3512	3512	3531	2938	3531	3531	3535	2943	3535	3535	2943
1-30 Stator Resistance (ohms)	0.0303	0.0303	0.0213	0.0430	0.0201	0.0201	0.0138	0.0308	0.0122	0.0122	0.0087	0.0197	0.0122
1-31 Rotor Resistance (ohms)	0.0257	0.0257	0.0179	0.0365	0.0146	0.0146	0.0103	0.0227	0.0091	0.0091	0.0066	0.0144	0.0091
1-35 Main Reactance (ohms)	5.3684	5.3684	3.9634	8.0570	3.005	3.005	2.1972	4.8857	2.8882	2.8882	2.1848	4.8553	2.8882
1-36 Iron Loss Resistance (ohms)	188.388	188.388	142.836	280.73	152.612	152.612	116.132	243.61	125.549	125.549	90.188	193.85	125.549
3-03 Maximum Reference (Hz)	60	50	60	60	60	50	60	60	60	50	60	60	50
4-14 Motor Speed High Limit (Hz)	60	50	60	60	60	50	60	60	60	50	60	60	50
6-15 Terminal 53 High Ref./ Feedback Value (Hz)	60	50	60	60	60	50	60	60	60	50	60	60	50
14-01 Switching Frequency (kHz)	3	3	3	2	3	3	3	2	3	3	3	2	3
14-11 Voltage at Main Fault (V)	391	340	323	489	391	340	323	489	391	340	323	489	340

(a) Compressor frame size is shown in model number digits 6 and 7.

Communications Interface

LonTalk® Interface (LCI-C)

UC800 provides an optional LonTalk® Communication Interface (LCI-C) between the chiller and a Building Automation System (BAS). An LCI-C LLID shall be used to provide “gateway” functionality between a LonTalk compatible device and the Chiller. The inputs/outputs include both mandatory and optional network variables as established by the LONMARK® Functional Chiller Profile 8040.

Note: For more information see ACC-SVN100*-EN.

BACnet® Interface (BCI-C)

Optional BACnet® Communication Interface for Chillers (BCI-C) is comprised of a Tracer® UC800 controller with interface software. It is a non-programmable communications module that allows units to communicate on a BACnet communications network.

Note: For more information, see BAS-SVP01*-EN.

Modbus™ Remote Terminal Unit Interface

Modicon Communication Bus (Modbus™) enables the chiller controller to communicate as a slave device on a Modbus network. Chiller setpoints, operating modes, alarms and status can be monitored and controlled by a Modbus master device.

Note: For more information, see BAS-SVP01*-EN.



Operating Principles

This section describes the overall operating principles of the Optimus™ water chiller.

General

Optimus™ units are single-compressor water-cooled liquid chillers. These units are equipped with unit-mounted starter/control panels.

The basic components are:

- Unit-mounted panel containing UC800 controller and input/output LLIDs
- Helical-rotary compressor
- Evaporator
- Electronic expansion valve
- Water-cooled condenser with integral subcooler
- Oil supply system
- Oil cooler (application dependent)
- Related interconnecting piping
- AFD (optional)

Refrigeration Cycle

The refrigeration cycle can be described using the pressure-enthalpy diagram shown in Figure 22. Key State Points are indicated on the figure and are referenced in the discussion following.

Figure 22. Pressure/enthalpy curve

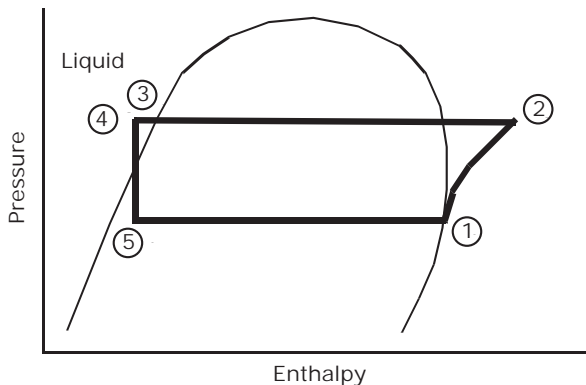

The Optimus™ chiller makes use of a shell-and-tube evaporator design with refrigerant evaporating on the shell side and water flowing inside tubes having enhanced surfaces. Refrigerant vapor leaves the evaporator as saturated vapor (State Pt. 1).

The refrigerant vapor generated in the evaporator flows to the suction end of the compressor. The compressor is a twin-rotor helical rotary type. The refrigerant flows across the motor, providing the necessary cooling, then enters the compression chamber. Refrigerant is compressed in

the compressor to discharge pressure conditions. Simultaneously, lubricant is injected into the compressor.

An oil management system provides an almost oil-free refrigerant to the shells to maximize heat transfer performance, while providing lubrication and rotor sealing to the compressor. The lubrication system ensures long compressor life and contributes to quiet operation.

Immediately following the compression process the lubricant and refrigerant are effectively divided using an oil separator.

The oil-free refrigerant vapor enters the condenser at State Pt. 2. Condensing is accomplished in a shell-and-tube heat exchanger where refrigerant is condensed on the shell side and water flows internally in the tubes. Cooling tower water, circulating through the condenser tubes, absorbs heat from this refrigerant and condenses it.

As the refrigerant leaves the bottom of the condenser (State Pt. 3), it enters an integral subcooler where it is subcooled before traveling to the electronic expansion valve (State Pt. 4). The pressure drop created by the expansion process vaporizes a portion of the liquid refrigerant.

The resulting mixture of liquid and gaseous refrigerant then enters the Evaporator Distribution system (State Pt. 5). The flash gas from the expansion process is internally routed to compressor suction, and while the liquid refrigerant is distributed over the tube bundle in the evaporator.

Refrigeration Circuits

Each unit has a single refrigerant circuit. Each refrigerant circuit includes compressor suction and discharge service valves, removable core filter, charging port, and sight glass. An electronically controlled expansion valve is provided to maintain variable capacity modulation over the entire building load and maintain proper refrigerant flow.

Compressor and Motor

Unit is equipped with a semi-hermetic, direct-drive, 3600 rpm 60 Hz (3000 rpm 50 Hz) rotary compressors that includes a capacity control slide valve, oil sump heater, and differential pressure refrigerant oil flow system. Optional AFD provides capacity control with lower speeds. Four pressure-lubricated rolling element bearing groups support the rotary assembly. Motor is suction gas-cooled, hermetically sealed, two-pole squirrel cage induction motor.

Evaporator and Condenser

Heat exchangers are shell and tube design. Standard tubes are externally finned, internally enhanced seamless

copper with lands at all tube sheets. All tube sheets are made of carbon steel. Tubes are mechanically expanded into tube sheets and mechanically fastened to tube supports. Evaporator tubes are 1.0- inch (25.4 mm) diameter and condenser tubes are 0.75-inch (19.05 mm) diameter. All tubes can be individually replaced.

Shells are carbon steel plate. The evaporator and condenser are designed, tested, and stamped in accordance with ASME Code for refrigerant-side/ working-side pressure of 200 psig (13.8 bars).

All water pass arrangements are available with grooved connections (150 or 300 psig waterside working pressure). All connections may be either right- or left-handed. Waterside shall be hydrostatically tested at 1.5X design working pressure.

Oil Management

The unit is configured with an oil management system that ensures proper oil circulation throughout the unit. The key components of the system include an oil separator, oil filter, oil sump and oil sump heater. An optional oil cooler is installed when the unit is used for high condensing temperature or low evaporator temperature conditions.

Unit-Mounted Starter

A unit-mounted starter and control panel is provided on every chiller. Microprocessor-based unit control modules (Tracer[®] UC800) provide for accurate chilled water control as well as monitoring, protection and adaptive limit functions. The “adaptive” nature of the controls intelligently prevents the chiller from operating outside of its limits, or compensates for unusual operating conditions, while keeping the chiller running rather than simply tripping due to a safety concern. When problems do occur, diagnostic messages assist the operator in troubleshooting.



Controls

Overview

Optimus™ RTHD units utilize the following control/interface components:

- Tracer® UC800 Controller
- Tracer AdaptiView™ TD7 Operator Interface

UC800 Specifications

This section covers information pertaining to the UC800 controller hardware.

Wiring and Port Descriptions

Figure 23 illustrates the UC800 controller ports, LEDs, rotary switches, and wiring terminals. The numbered list following Figure 23 corresponds to the numbered callouts in the illustration.

Figure 23. Wiring locations and connection ports

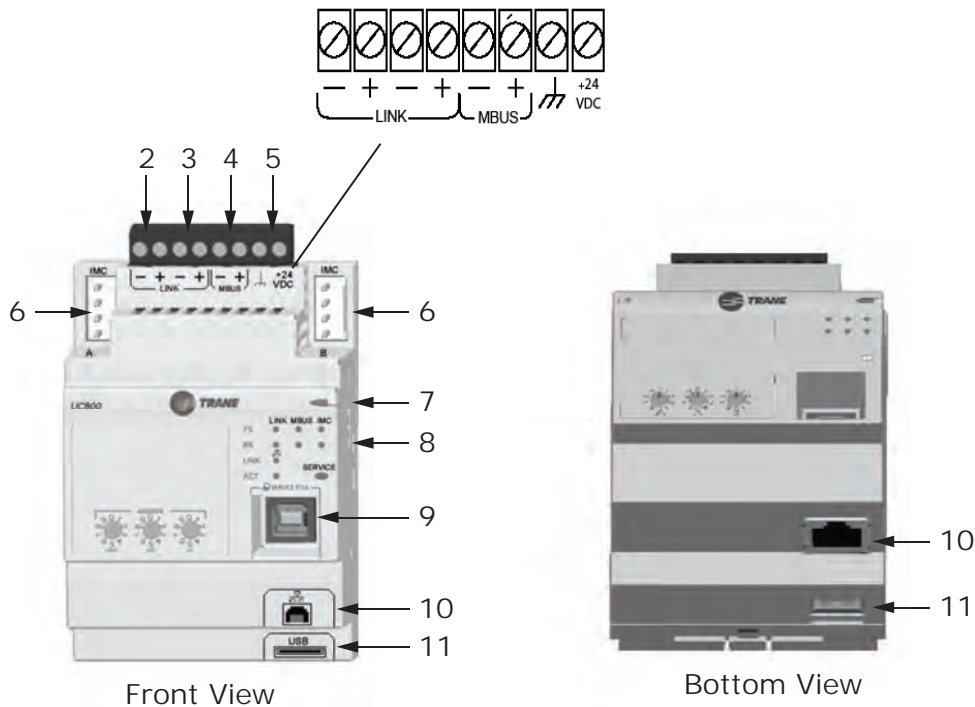

1. Rotary Switches for setting BACnet® MAC address or MODBUS ID.
2. LINK for BACnet MS/TP, or MODBUS Slave (two terminals, ±). Field wired if used.
3. LINK for BACnet MS/TP, or MODBUS Slave (two terminals, ±). Field wired if used.
4. Machine bus for existing machine LLIDs (IPC3 Tracer bus 19.200 baud). *IPC3 Bus: used for Comm4 using TCI or LonTalk® using LCI-C.*
5. Power (210 mA at 24 Vdc) and ground terminations (same bus as item 4). Factory wired.
6. Not used.
7. Marquee LED power and UC800 Status indicator (Table 20, p. 53).
8. Status LEDs for the BAS link, MBus link, and IMC link.
9. USB device type B connection for the service tool (Tracer® TU).
10. The Ethernet connection can *only* be used with the Tracer AdaptiView™ display.
11. USB Host (not used).

Communication Interfaces

There are four connections on the UC800 that support the communication interfaces listed. See [Figure 23, p. 52](#) for the locations of each of these ports.

- BACnet® MS/TP
- MODBUS™ Slave
- LonTalk™ using LCI-C (from the IPC3 bus)
- Comm 4 using TCI (from the IPC3 bus)

Rotary Switches

There are three rotary switches on the front of the UC800 controller. Use these switches to define a three-digit address when the UC800 is installed in a BACnet or MODBUS system (e.g., 107, 127, etc.).

Note: Valid addresses are 001 to 127 for BACnet and 001 to 247 for MODBUS.

LED Description and Operation

There are 10 LEDs on the front of the UC800. [Figure 24](#) shows the locations of each LED and [Table 20, p. 53](#) describes their behavior in specific instances.

Figure 24. LED locations

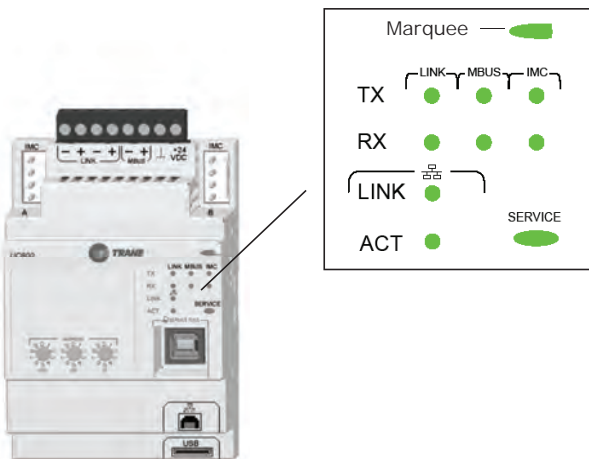

Table 20. LED behavior

LED	UC800 Status
Marquee LED	Powered. If the Marquee LED is green solid, the UC800 is powered and no problems exist.
	Low power or malfunction. If the Marquee LED is red solid, the UC800 is powered, but there are problems present.
	Alarm. The Marquee LED blinks Red when an alarm exists.
LINK, MBUS, IMC	The TX LED blinks green at the data transfer rate when the UC800 transfers data to other devices on the link.
	The Rx LED blinks yellow at the data transfer rate when the UC800 receives data from other devices on the link.
Ethernet Link	The LINK LED is solid green if the Ethernet link is connected and communicating.
	The ACT LED blinks yellow at the data transfer rate when data flow is active on the link.
Service	The Service LED is solid green when pressed. For qualified service technicians only. Do not use.

Important: Maintain at least 6" between low-voltage (<30V) and high voltage circuits to prevent control malfunctions, do not run low voltage wiring (<30 V) in conduit with conductors carrying more than 30 volts.

Tracer AdaptiView™ TD7 Display

Operator Interface

Information is tailored to operators, service technicians, and owners. When operating a chiller, there is specific information you need on a day-to-day basis—setpoints, limits, diagnostic information, and reports. Day-to-day operational information is presented at the display. Logically organized groups of information—chiller modes of operation, active diagnostics, settings and reports put information conveniently at your fingertips.

Figure 25. TD7 screens



Operator Display Boot Screen



Display Loading Data



Home Screen, Auto Mode

Home Screen

The home screen (Table 26) provides the most frequently needed chiller status information on “touch targets” (the entire white rectangular areas) for each chiller component. Touching any touch target displays a screen containing more chiller status information related to each component.

Figure 26. Home screen

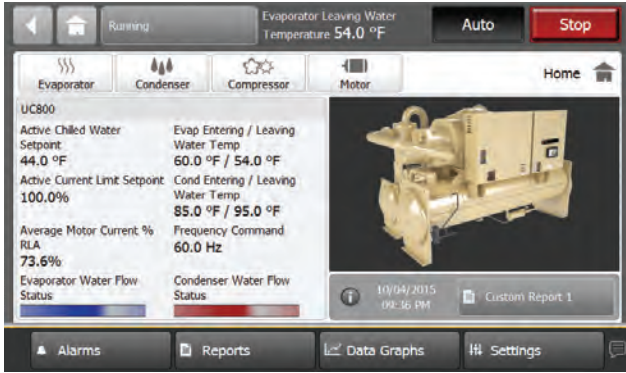

Table 21. Home screen items

Description	Resolution	Units
Active Chilled Water Setpoint	X.X	°F /°C
Active Current Limit Setpoint	X.X	%RLA
Average Motor Current %RLA	X.X	%RLA
Evap Entering/Leaving Water Temp	X.X	°F /°C
Cond Entering/Leaving Water Temp	X.X	°F /°C
Frequency Command	X.X	Hz
Evaporator Water Flow Status		
Condenser Water Flow Status		

Viewing Chiller Operating Modes

On the Reports screen, touch Chiller Operating Modes to view the current operating status of the chiller in terms of the top-level operating mode and submodes.

Table 22. Operating modes

Chiller Modes	Description
MP Resetting	
Stopped	The chiller is not running and cannot run without intervention. Further information is provided by the sub-mode:
Local Stop	Chiller is stopped by TD7 Stop button command– cannot be remotely overridden.
Immediate Stop	Chiller is stopped by the TD7 Panic Stop (by pressing Stop then Immediate Shutdown in succession) – previous shutdown was manually commanded to shutdown immediately.
Diagnostic Shutdown – Manual Reset	The chiller is stopped by a diagnostic that requires manual intervention to reset.
Run Inhibit	The chiller is currently being inhibited from starting (and running*), but may be allowed to start if the inhibiting or diagnostic condition is cleared. Further information is provided by the sub-mode:
Diagnostic Shutdown – Auto Reset	The entire chiller is stopped by a diagnostic that may automatically clear.

Note: You can also access the Chiller Operating Modes screen from the chiller status button in the upper left corner of the screen.

Figure 27. Chiller operating modes

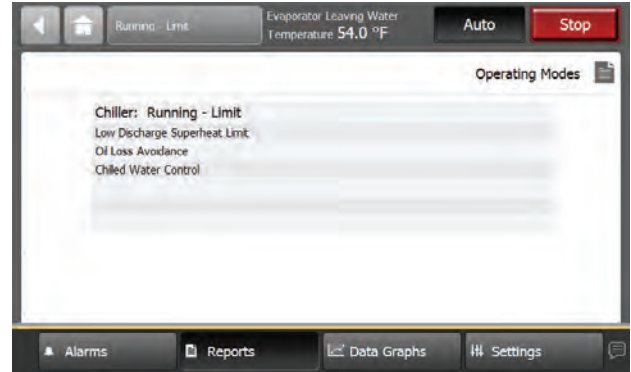

Table 22. Operating modes (continued)

Chiller Modes	Description
Starting is Inhibited by External Source	The chiller is inhibited from starting (and running) by the "external stop" hardwired input.
Start Inhibited by BAS	The chiller is inhibited from starting (and running) by command from a Building Automation System via the digital communication link (com 4 or com 5).
Waiting for BAS Communications	This is a transient mode - 15-min. max, and is only possible if the chiller is in the Auto - Remote command mode. After a power up reset, it is necessary to wait for valid communication from a Building Automation System (Tracer) to know whether to run or stay inhibited. Either valid communication will be received from the Building Automation System (e.g. Tracer), or a communication diagnostic ultimately will result. In the latter case the chiller will revert to Local control.
Power Up Delay Inhibit min:sec	The compressor is currently being inhibited from starting as part of the power up start delay (or staggered start) feature. This feature is intended to prevent multiple chillers from all starting simultaneously if power is restored to all chillers simultaneously.
Low Differential Refrigerant Pressure Cool-Down Time min:sec	Contact your local Trane service office.
Auto	The chiller is not currently running but can be expected to start at any moment given that the proper conditions and interlocks are satisfied. Further information is provided by the sub-mode:
Waiting For Evap Water Flow	The chiller will wait up to 20 minutes in this mode for evaporator water flow to be established per the flow switch hardwired input.
Waiting for A Need to Cool	The chiller will wait indefinitely in this mode, for an evaporator leaving water temperature higher than the Chilled Water Setpoint plus the Differential to Start.
Waiting to Start	The chiller is not currently running and there is a call for cooling but start is delayed by certain interlocks or proofs. Further information is provided by the sub-mode:
Waiting For Cond Water Flow	The chiller will wait up to 20 minutes in this mode for condenser water flow to be established per the flow switch hardwired input.
Start Inhibited Waiting for Oil	The chiller will wait up to 2 minutes in this mode for oil level to appear in the oil tank.
Condenser Water Pump Pre-Run Time min:sec	The chiller will wait up to 30 minutes (user adjustable) in this mode for to allow the condenser water loop to equalize in temperature
Restart Inhibit min:sec	The compressor is currently unable to start due to its restart inhibit timer. A given compressor is not allowed to start until 5 minutes (adj) has expired since its last start, once a number of "free starts" have been used up.
Waiting For EXV Preposition	The Chiller will wait for the time it takes the EXV to get to its commanded pre-position prior to starting the compressor. This is typically a relatively short delay and no countdown timer is necessary (less than 15 seconds)
Minimum Condenser Water min:sec	Only possible when Condenser Head Pressure Control option is enabled, this wait may be necessary due to the Head Pressure control device's stroke time.
Condenser Water Regulating Control min:sec	Only possible when Condenser Head Pressure Control option is enabled, this wait may be necessary due to the Head Pressure control device's stroke time
Running	The chiller, circuit, and compressor are currently running. Further information is provided by the sub-mode:
High Discharge Temp Limit	The compressor is running and is being forced loaded to its step load point, without regard to the leaving water temperature control, to prevent tripping on high compressor discharge temperature.
Base Loaded	Chiller is running in "Base Load" operation where the capacity of the chiller is controlled to maintain a given current per an adjustable set point. The chiller is forced to run without regard to the chilled water temperatures and the differential to start and stop
Capacity Control Softloading	The chiller is running, but loading is influenced by a gradual 'pulldown" filter on the chilled water temperature setpoint. The settling time of this filter is user adjustable as part of the softload control feature.
Current Control Softloading	The chiller is running, but loading is influenced by a gradual filter on the current limit setpoint The starting current and the settling time of this filter is user adjustable as part of the softload control feature.
EXV Controlling Differential Pressure	Liquid level control of the Electronic Expansion Valve has temporarily been suspended. The EXV is being modulated to control for a minimum differential pressure. This control implies low liquid levels and higher approach temperatures, but is necessary to provide minimum oil flow for the compressor until the condenser water loop can warm up to approx 50F.
Chilled Water Control	Unit is running in the Cooling Mode of operation and is attempting to control to the active Chilled Water Setpoint.
Running – Limited	The chiller, circuit, and compressor are currently running, but the operation of the chiller/ compressor is being actively limited by the controls. Further information is provided by the sub-mode.* See the section below regarding criteria for annunciation of limit modes

Controls

Table 22. Operating modes (continued)

Chiller Modes	Description
Condenser Pressure Limit	The circuit is experiencing condenser pressures at or near the condenser limit setting. Compressors on the circuit will be unloaded to prevent exceeding the limits. *
Low Evaporator Refrigerant Temperature Inhibit	The circuit is experiencing saturated evaporator temperatures at or near the Low Refrigerant Temperature Cutout setting. Compressors on the circuit will be unloaded to prevent tripping. *
Capacity Limited by Low Liquid Level	The circuit is experiencing low refrigerant liquid levels and the EXV is at or near full open. The compressors on the circuit will be unloaded to prevent tripping. *
Current Limit	The compressor is running and its capacity is being limited by high currents. The current limit setting is 100% RLA (to avoid overcurrent trips) or lower as set by the compressor's "share" of the active current limit (demand limit) setting for the entire chiller. *
Phase Unbalance Limit	The compressor is running and its capacity is being limited by excessive phase current unbalance. *
Low Discharge Superheat Limit	This is limit control that acts to prevent chiller shutdown when the discharge superheat approaches the limit setpoint by reducing the liquid level and unloading the slide valve.
Oil Loss Avoidance	This is limit control that acts to prevent chiller shutdown when the estimated refrigerant flow approaches the calculated minimum flow by increasing the slide valve capacity and/or VFD frequency
Note: Other normal running modes (see above) may also appear under this top level mode	
Shutting Down	The chiller is still running but shutdown is imminent. The chiller is going through a compressor run-unload sequence. Shutdown is necessary due to one (or more) of the following sub-modes:
Local Stop	Chiller is in the process of being stopped by TD7 Stop button command
immediate Stop	Chiller is in the process of being stopped by TD7 Panic Stop command
Diagnostic Shutdown – Manual Reset	Chiller is in the process of being stopped by a Latching Diagnostic shutdown – Manual Reset is required to clear
Diagnostic Shutdown – Auto Reset	Chiller is in the process of being stopped by a Diagnostic shutdown – Automatic clearing of the diagnostic is possible if condition clears.
Compressor Unloading (min:sec)	The compressor is in its "run – unload" state in which it is being continuously unloaded for 40 sec prior to shutdown.
Starting is Inhibited by External Source	Chiller is in the process of being stopped by the External Stop hardwired input
Start Inhibited by BAS	The Chiller is in the process of shutdown due to a command from the Building Automation System (e.g. Tracer)
Evaporator Water Pump Off Delay min:sec	
Service Override	The Chiller is in a Service Override mode
Service Pumpdown	The chiller, circuit, and compressor is running via a manual command to perform a Service Pumpdown. Both evap and condenser water pumps are commanded to be running. The EXV is being held wide open, but the manual liquid line service valve should be closed.

Alarms

You can use the display to view alarms and to reset them. Alarms are communicated to the display immediately upon detection.

Viewing the Alarms Screen

Touch the Alarms button in the home screen menu (Figure 26, p. 54) to view the Alarms screen. A table of active alarms appears that is organized chronologically with the most recent at the top of the list, as shown in Figure 28. This example shows the default view, which appears each time you return to the screen. List can be sorted by any of the other columns if desired.

Note: A page number appears in the lower right corner of the screen. If a screen contains more than one page, up/down arrows also appear for viewing the other pages.

Figure 28. Alarm screen

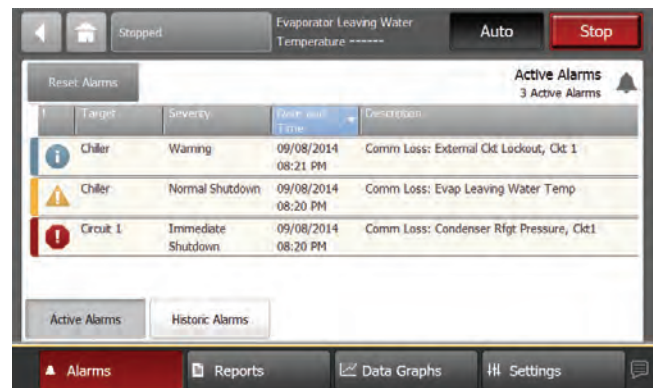

The Alarms screen is accessible by depressing the Alarms enunciator. A verbal description will be provided.

A scrollable list of the last active Alarms is presented. Performing a "Reset Alarms" will reset all active Alarms

regardless of type, machine or circuit. The scrollable list will be sorted by time of occurrence.

“Alarms” Key Behavior:

- Alarm Shutdown (immediate) has occurred: Flash red
- Alarm Shutdown (normal) has occurred: Flash yellow
- Informational warning is present: Flash blue

No alarms present: Default button color, not flashing

Reports

You can use the TD7 display to view a variety of reports and to create and edit a custom report. All reports contain live data that refreshes every 2–5 seconds.

Viewing the Reports Screen

Touch the Reports button in the main menu area (Figure 4) to view the Reports screen. The Reports screen contains the following buttons:

- Custom Report1
- Custom Report2
- Custom Report3
- Evaporator
- Condenser
- Compressor
- Motor
- About
- Operating Modes
- Log Sheet
- ASHRAE Chiller Log

Each button links to the report named on the button.

Figure 29. Report screen

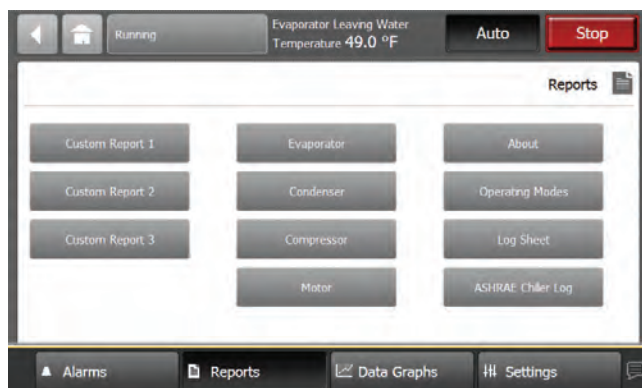

The Reports tab allows a user to select from a list of reports headings. Each report will generate a list of status items as defined in the tables that follow.

Editing a Custom Report

You can edit the custom report by adding, removing, or re-order data as follows:

1. On the Custom Report screen, touch Edit. The Edit Custom Report screen appears.
2. Add, remove, or re-order as follows:
 - a. To add an item to the custom report, touch it. It responds by changing to blue. You can use the arrows to scroll through the rest of the items that can be added to the custom report. Then touch Add to move the selected item to the box on the right side of the screen.
 - b. To remove an item from the custom report, touch it. It responds by changing to blue. You can use the arrows to scroll through the rest of the items that can be removed from the custom report. Then touch Remove to move the selected item to the box on the left side of the screen.
 - c. To re-order items in the custom report, touch it. It responds by changing to blue. Use the arrows to change the order of a highlighted item.
3. To save and view your edited custom report, touch Save.

Figure 30. Edit custom report screen

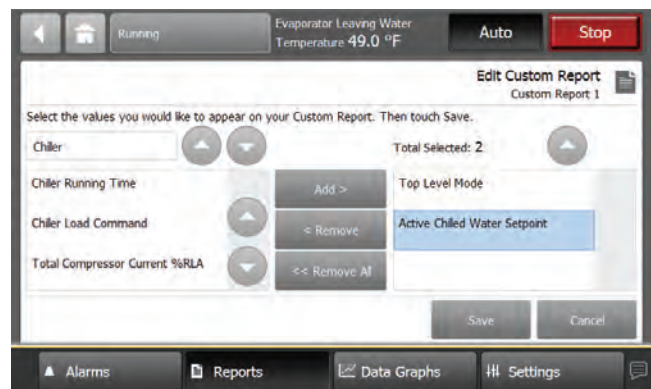

Figure 31. Report evaporator screen



Table 23. Report evaporator screen items

Description	Resolution	Units
Active Chilled Water Setpoint	X.X	°F / °C
Evaporator Entering Water Temperature	X.X	°F / °C
Evaporator Leaving Water Temperature	X.X	°F / °C
Evaporator Water Flow Status	Flow, No Flow	Text
Evaporator Water Pump Override	Auto, On	Text
Evaporator Approach Temperature	X.X	°F / °C
EXV Position Percent	X.X	%
Evaporator Refrigerant Pressure	XXX.X	PSIA/kPa
Evaporator Saturated Rfqt Temp	X.X	°F / °C
Evaporator Refrigerant Liquid Level	X.XX	in/mm

Figure 32. Report condenser screen



Table 24. Report condenser screen items

Description	Resolution	Units
Condenser Entering Water Temperature	X.X	F / C
Condenser Leaving Water Temperature	X.X	F / C
Condenser Water Flow Status	Flow, No Flow	Text
Condenser Water Pump Override	Auto, On	Text
Condenser Approach Temperature	X.X	F / C
EXV Position Percent	X.X	%
Condenser Refrigerant Pressure	XXX.X	PSIA/kPa
Condenser Saturated Rfqt Temp	X.X	F / C
Differential Refrigerant Pressure	XXX.X	PSIA/kPa
Outdoor Air Temperature	X.X	F / C

Figure 33. Report compressor screen

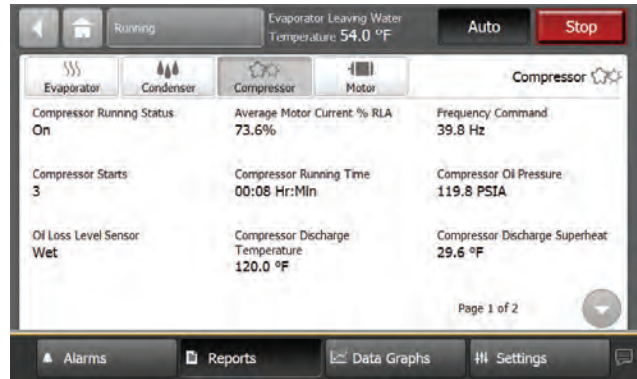

Table 25. Report compressor screen items

Description	Resolution	Units
Compressor Running Status	On, Off	Text
Average Motor Current %RLA	XX.X%	%RLA
Compressor Starts	XX	Text
Compressor Running Time	XX:XX	Hr:Min
Oil Loss Level Sensor	Wet, Dry	Text
Discharge Temperature	X.X	°F / °C
Discharge Temperature	X.X	°F / °C
Compressor Oil Pressure	XXX.X	PSIA/kPa
Evaporator Refrigerant Pressure	XXX.X	PSIA/kPa
Condenser Refrigerant Pressure	XXX.X	PSIA/kPa
Differential Refrigerant Pressure	XXX.X	PSIA/kPa
Frequency Command	XX.X	Hz

Figure 34. Report motor screen

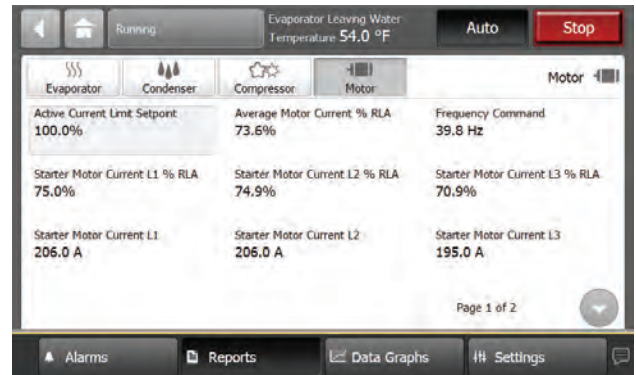

Table 26. Report motor screen items

Description	Resolution	Units
Active Current Limit Setpoint	X.X	%RLA
Average Motor Current %RLA	X.X	%RLA
Starter Motor Current L1 %RLA	X.X	%RLA
Starter Motor Current L2 %RLA	X.X	%RLA
Starter Motor Current L3 %RLA	X.X	%RLA
Starter Motor Current L1	X.X	A
Starter Motor Current L1	X.X	A
Starter Motor Current L1	X.X	A
Starter Input Voltage AB	XXX.X	V
Starter Input Voltage BC	XXX.X	V
Starter Input Voltage CA	XXX.X	V
Average Motor Current	X.X	A
Average Phase Voltage	XXX.X	V
Frequency Command	XX.X	Hz

Equipment Settings

You can use the TD7 display to monitor and change a variety of equipment settings.

Viewing the Settings Screen

Touch the Settings button in the main menu area (see [Figure 26, p. 54](#)) to view the Settings screen. Equipment Settings identifies a column of buttons located on the screen (see the outlined column in [Figure 35](#)). The buttons are:

- Chiller Settings
- Feature Settings
- Chiller Water Reset
- Manual Control Settings

Each of these buttons provide access to a screen that contains additional buttons related to each topic. This section provides detailed information about these screens.

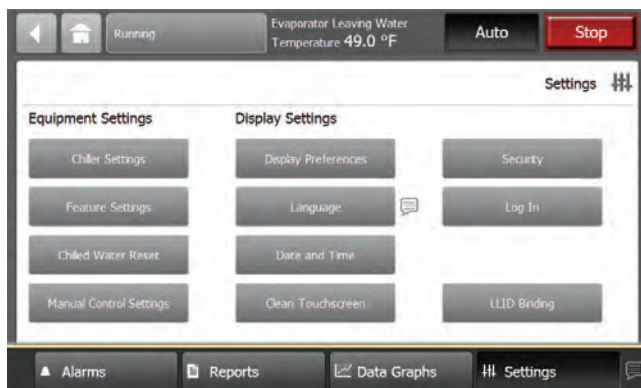
Figure 35. Setting screen

Viewing and Changing Equipment Settings

Each button in the Equipment Settings column on the Settings screen takes you to a menu screen that contains a group of buttons. Each button displays the name of a setting and its current value ([Figure 36](#)). Touch any button to view a screen where you can change the setting for the feature shown on the button.

Note: A page number appears in the lower right corner of the screen. If a screen contains more than one page, up/down arrows also appear for viewing the other pages, as in [Figure 36](#).

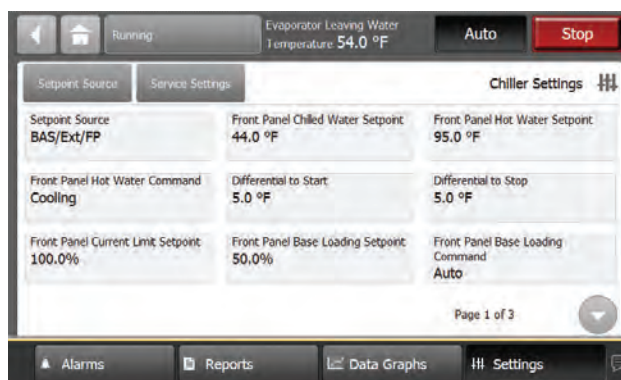
Figure 36. Equipment setting screen (Chiller setting shown)

To change an equipment setting, follow this procedure:

1. Touch one of the button in the Equipment Settings column on the Settings screen, such as Chiller Settings. The corresponding screen appears (in this case, the Chiller Settings screen).
2. Touch the button that shows the equipment setting you want to change. A screen that allows you to change the equipment setting appears. There are two types of these screens:
 - a. For screens with button selections ([Figure 37](#)), touch the button that represents the setting you want. The button becomes shaded, and a Save button appears at the bottom of the screen.
 - b. For screens with numerical keypads ([Figure 38](#)), touch the appropriate numbers to change the current value. The new value appears above the keypad.
3. Touch Save to complete the change. The current value is updated in the upper left side of the screen, demonstrating that the change has been communicated to the Tracer[®] UC800 controller. The screen you were previously viewing appears.

Figure 37. Chilled water reset type screen

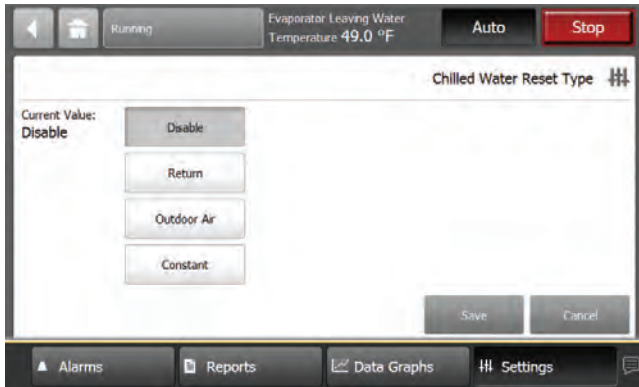
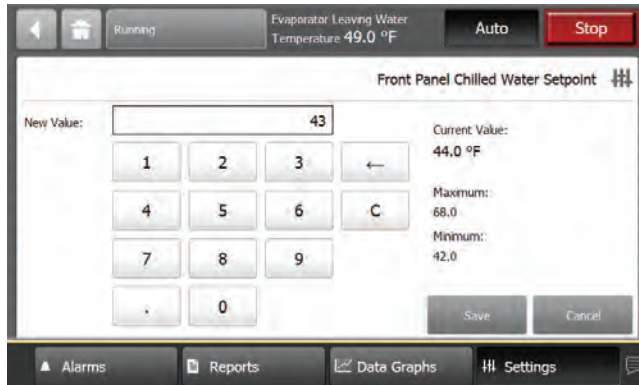

Figure 38. Changed chilled water setpoint screen



Keypad features:

- When you enter a new number, the value in the New value field is deleted and replaced with the new entry.
- The backspace (arrow) key deletes the characters you previously entered.
- If the keypad is used to enter a setpoint that is out of range, an error dialog will appear when you touch the Save button.
- Keypads that allow negative numbers have positive and negative number (+/-) keys.

Table 27. Settings screen items

Description	Resolution	Units
Chiller Settings		
Active Chilled Water Setpoint	XXX.X	°F / °C
Active Current Limit Setpoint	XXX %	%RLA
Active Panel Base Load Cmd	On/Auto	Text
Active Base Loading Setpoint	XXX	%
Active Base Loading Command	On/Auto	Text
Differential to Start	XXX.X	°F / °C
Differential to Stop	XXX.X	°F / °C
Setpoint Source (BAS/Ext/FP, Ext/Front Panel, Front Panel)	BAS/Ext/FP	Text
Evaporator Water Pump Off Delay	XX	Min
Condenser Pump Prestart Time	XX	Min
High Evap Water Temp Cutout	XXX.X	°F / °C
Evaporator Leaving Water Temp Cutout	XX.X	°F / °C
Low Refrigerant Temperature Cutout	XX.X	°F / °C
Current Limit Softload Start Point	XXX.X	%
Current Limit Control Softload Time	XXXX	Sec
Capacity Control Softload Time	XXXX	Sec
Local Atmospheric Pressure	XXX.X	psi/kPa
Power Up Start Delay	XXX	Min
Feature Settings		
External Chilled/Hot Water Setpoint (Enable/Disable)		Text
External Current Limit Setpoint (Enable/Disable)		Text
LCI-C Diagnostic Encoding (Enable/Disable)		Text
Chilled Water Reset (Constant, Outdoor, Return, Disable),	Disable	Text
Return Reset Ratio	XXX	%
Return Start Reset	XXX.X	°F / °C
Return Maximum Reset	XXX.X	°F / °C
Outdoor Reset Ratio	XXX	%
Outdoor Start Reset	XXX.X	°F / °C
Outdoor Maximum Reset	XXX.X	°F / °C
Mode Overrides		
Evap Water Pump (Auto, On)	Auto	Text
Cond Water Pump (Auto, On)	Auto	Text

Service Settings

Setpoints on the Service Settings screen are only intended for use by experienced service personnel. Setpoints include security, if enabled.

The Service Settings screen is found through Chiller Settings, and includes a warning message for the user.

Figure 39. Warning message

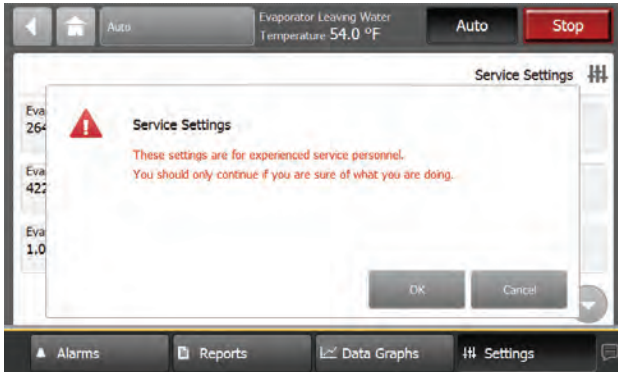
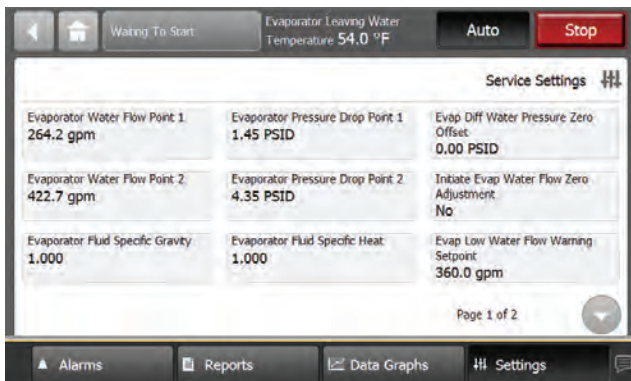

Figure 40. Service setting screen



Display Settings

You can use the Tracer AdaptiView™ display to change the format of the information that appears on the display, and to clean the touch screen.

Viewing the Settings Screen

Touch the Settings button in the main menu area (Figure 26, p. 54) to view the Settings screen. Display Settings identifies a column of buttons located on the screen (see Figure 41). The buttons are:

- Display Preferences
- Language
- Date and Time
- Clean Display

Each button provide access to a screen that is related to the button name.

Viewing and Changing Display Preferences

On the Settings screen, touch Display Preferences to view a screen containing these buttons (see Figure 29):

- Date Format
- Date Separator
- Time Format
- Unit System
- Pressure Units
- Number Format

Figure 41. Display preference screen

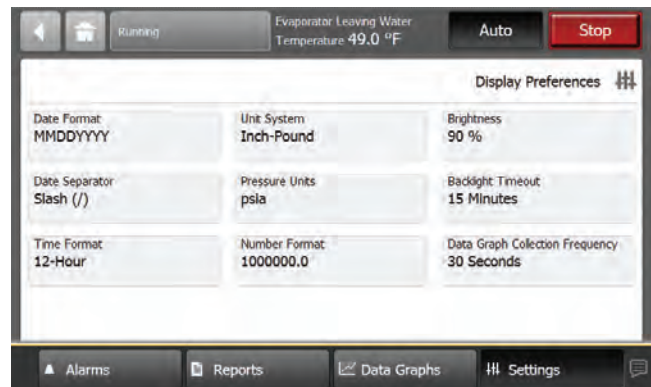

Each of the buttons shows the name of a display preference and its format (current value). Touch any of these buttons to view a screen where you can change the format. The button representing the format currently used is shaded (see the "MMDDYYYY" button).

Figure 42. Date format page

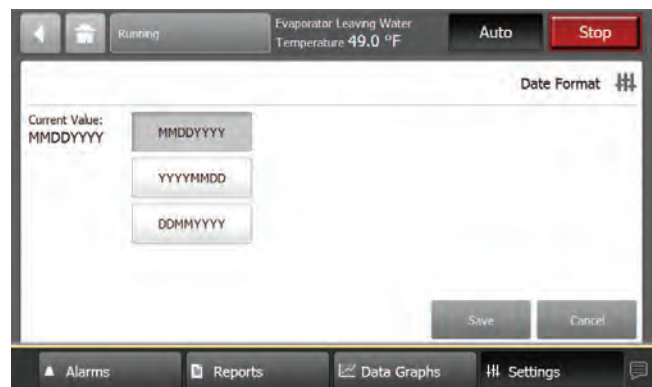

To change the format:

1. Touch the button that shows that format you prefer.
2. Touch Save to confirm your selection and to return to the Display Preferences screen.

Controls

Date Format . Use the Date Format screen to choose from the following date formats:

- MMDDYYYY (default)
- YYYYMMDD
- DDMMYYYY

Date Separator . Use the Date Separator screen to choose from the following date formats:

- None
- Slash (default)
- Hyphen

Time Format . Use the Time Format screen to choose from the following time formats:

- 12 hour (default)
- 24 hour

Units System . Use the Display Units screen to choose from the following display units:

- SI
- Inch-Pounds (default)

Pressure Units . Use the Pressure Units screen to choose from the following pressure units:

- kPaA (default if “SI” is chosen for display units)
- kPaG
- PSIA (default if “Inch-Pound” is chosen for display units)
- PSIG

Number Format .

- 1000000.0
- 1000000,0

Figure 43. Language page



The language that is currently in use on the display is expressed as the current value on the Language screen. The button that displays the current value is shaded (see the “English” button in Figure 19 as an example).

To change the language:

1. Touch the button that identifies the language you prefer.
2. Touch Save to confirm your selection and to return to the Settings screen.

Figure 44. Date and time screen

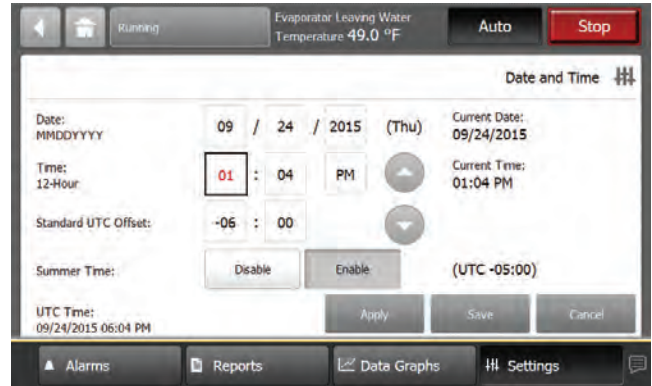

The current date and time for the display is expressed as the current value. The current value appears below the center line on the screen.

Above the center line, the following date and time attributes appear:

- Month
- Day
- Year
- Hour
- Minute
- AM/PM

To change the date or time:

1. Touch the square presenting the attribute you want to change. The square becomes highlighted.
2. Touch the up or down arrow key on the screen until the your desired selection appears. Repeat the process for any other attributes you want to change.
3. Touch Save to confirm your selection and return to the Settings screen.

Note: Alternately, fields can be edited by touching the highlighted square a second time to access a keypad.

Cleaning the Display

On the Settings screen, touch Clean Display to disable the Tracer AdaptiView™ display screen for 5 seconds after finger is removed. This process allows screen cleaning without it responding to touch. During this time, the screen is black with a number in the center that counts down the seconds. After 5 seconds, the Settings screen re-appears.

Figure 45. Countdown screen

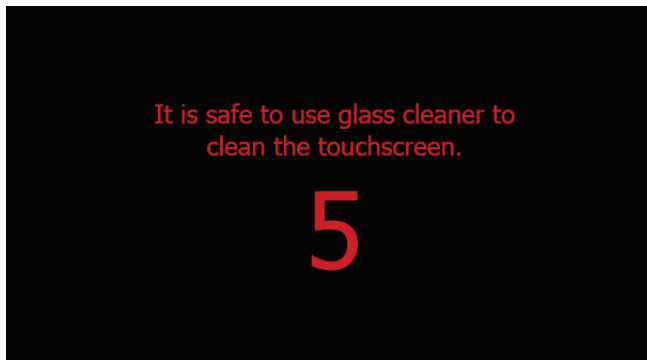

Security Settings

If security is enabled, the Tracer AdaptiView™ display requires that you log in with a four-digit security PIN to make setting changes that are protected by security. This feature prevents unauthorized personnel from doing so. There are two levels of security, each allowing specific changes to be made.

You can view all data without logging in. The log-in screen appears only when you try to change a setting that is protected by security, or when you touch the Log in button from the Settings screen.

Disabling/Enabling Security

The Tracer AdaptiView™ display gives you the ability to disable or enable the security feature that allows a user to log in and log out.

To disable security, you must be logged in:

1. From the Settings screen, touch the Security button. The Security screen appears (Figure 46).

Note: If you are logged out, the Log in screen appears.

2. Touch the Disable button. The button becomes shaded.
3. Touch Save. The Settings screen appears with only the Security button visible. The Log in/Logout button is gone.

To enable security:

1. From the Settings screen, touch the Security button. The Security screen appears (Figure 46).
2. Touch the Enable button. The button becomes shaded.

3. Touch Save. The Settings screen appears with a Log out button, in addition to the Security button.

Figure 46. Security screen - disable

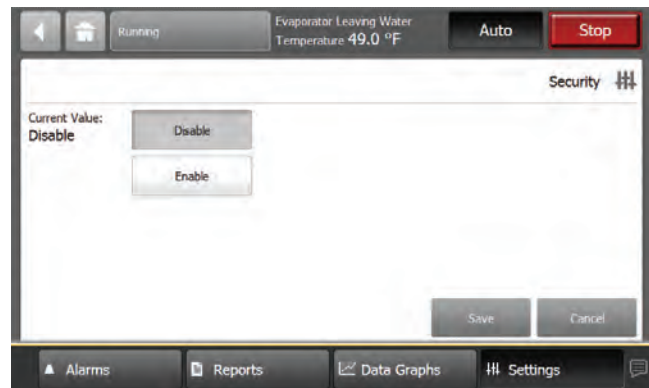
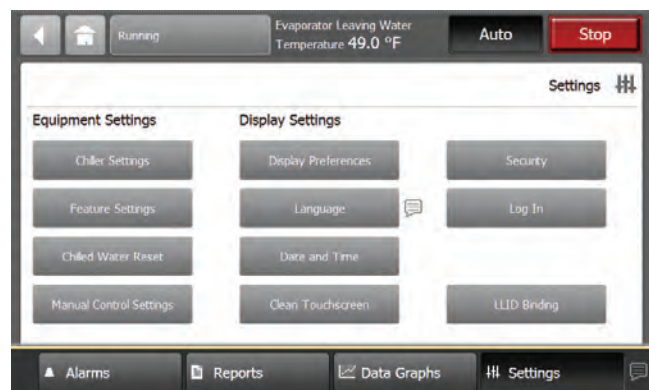

Figure 47. Security settings screen



Logging In

There are two levels of security:

- Security Level 1 allows users to change a limited group of secure settings. The default security PIN is 1111.
- Security Level 2 allows users to change all secure settings. The default security PIN is 7123.

A technician must use the Tracer® TU service tool to define a different PIN, or to recall a PIN that has been forgotten. When defining a PIN in Tracer® TU, the technician enters a 4-digit PIN that corresponds with the desired level of security.

To log in:

1. Touch the Log in button. The Log in screen appears (Figure 47).
2. Use the keypad to enter your PIN.
 - a. The PIN is a four-digit number, which was configured for your system with the Tracer® TU service tool.
 - b. As you enter the number, the PIN remains hidden by asterisks.

Note: If you enter an invalid PIN, an error message appears on the Log in screen.

Controls

3. Touch Save.
 - a. If you viewed the Log in screen from touching Log in on the Settings screen, the Settings screen appears with a Log out button on it.
 - b. If the Log in screen appeared when you tried to change a setting, you return to that setting screen.

Note: The PIN is valid until 30 minutes of inactivity passes, or until you log out.

Figure 48. Log in screen

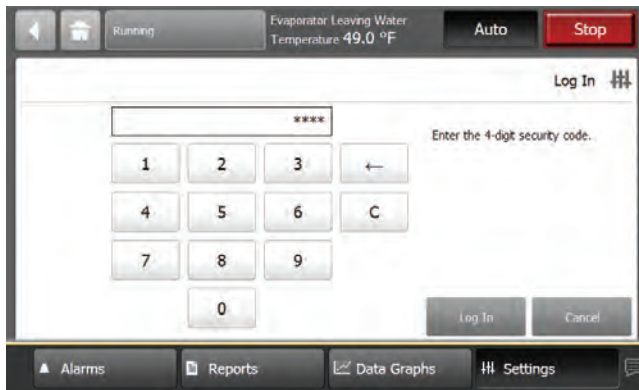

Logging Out

To log out:

1. Touch the Log out button. A confirmation screen appears (Figure 49).
2. Touch Yes to confirm that you want to log out. The Settings screen appears with a Log in button on it.

Figure 49. Log out confirmation screen

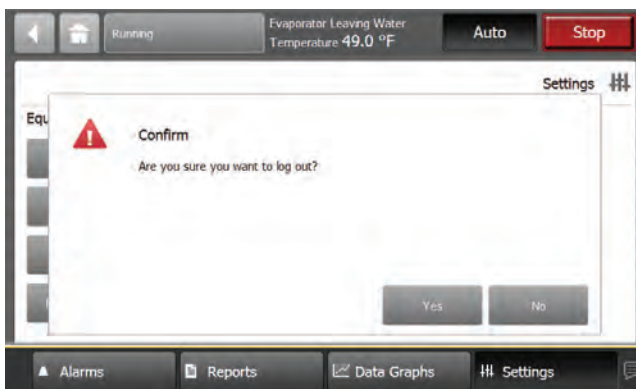

Tracer[®] TU

Tracer[®] TU (non-Trane personnel, contact your local Trane office for software) adds a level of sophistication that improves service technician effectiveness and minimizes chiller downtime. The Tracer AdaptiView[™] control's operator interface is intended to serve only typical daily tasks. The portable PC-based service-tool software, Tracer[®] TU, supports service and maintenance tasks.

Tracer[®] TU serves as a common interface to all Trane[®] chillers, and will customize itself based on the properties of the chiller with which it is communicating. Thus, the service technician learns only one service interface.

The panel bus is easy to troubleshoot using LED sensor verification. Only the defective device is replaced. Tracer[®] TU can communicate with individual devices or groups of devices.

All chiller status, machine configuration settings, customizable limits, and up to 100 active or historic diagnostics are displayed through the service-tool software interface.

LEDs and their respective Tracer[®] TU indicators visually confirm the availability of each connected sensor, relay, and actuator.

Tracer[®] TU is designed to run on a customer's laptop, connected to the Tracer AdaptiView[™] control panel with a USB cable. Your laptop must meet the following hardware and software requirements:

- 1 GB RAM (minimum)
- 1024 x 768 screen resolution
- Ethernet 10/100 LAN card
- Available USB 2.0 port
- *Microsoft[®] Windows[®] 7* Enterprise or Professional operating system (32-bit or 64-bit) or Windows 8.1.

Important: *Tracer[®] TU V8.6 was the final release to support Windows XP. Beginning with Tracer[®] TU V9.0, you will need to migrate to Windows 7 or Windows 8.1 operating system.*

Notes:

- *Tracer[®] TU is designed and validated for this minimum laptop configuration. Any variation from this configuration may have different results. Therefore, support for Tracer[®] TU is limited to only those laptops with the configuration previously specified.*

For more information, see TTU-SVN01-EN Tracer[®] TU Getting Started Guide.*

Figure 50. Tracer[®] TU

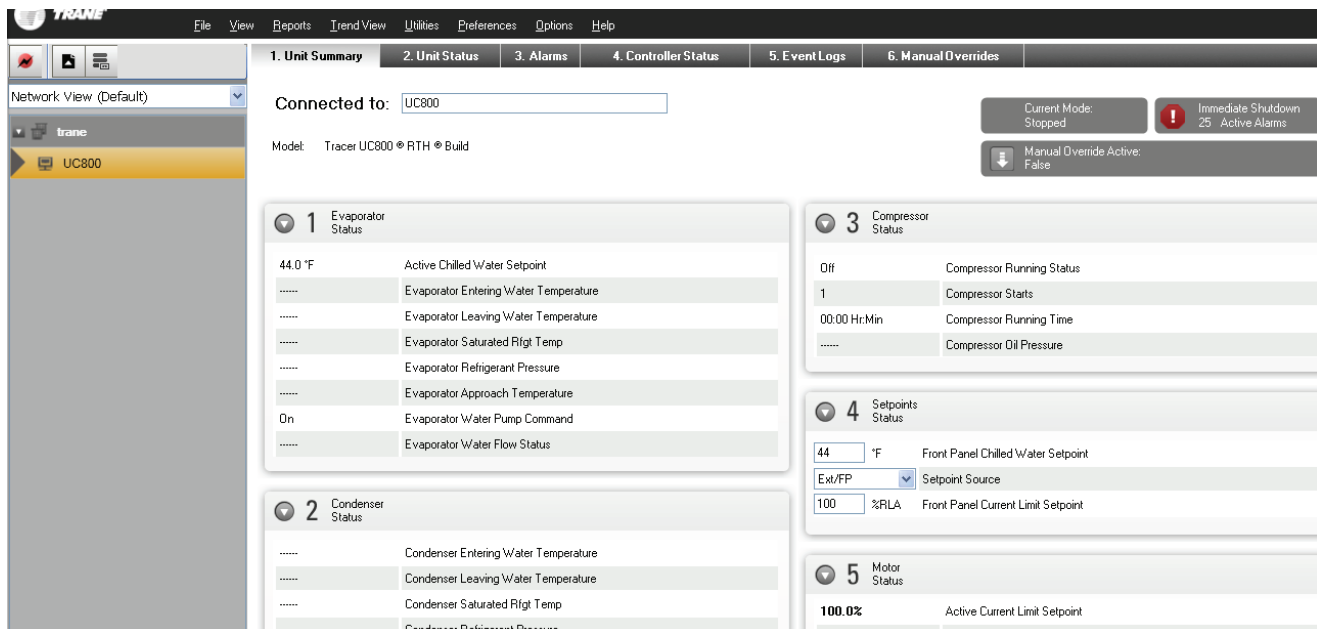



Pre-Start

Upon completion of installation, complete the Optimus™ RTHD Installation Completion Check Sheet and Request for Trane Service checklist in chapter [“Log and Check Sheets,” p. 95.](#)

Important: *Start-up must be performed by Trane or an agent of Trane specifically authorized to perform start-up and warranty of Trane products. Contractor shall provide Trane (or an agent of Trane specifically authorized to perform start-up) with notice of the scheduled start-up at least two weeks prior to the scheduled start-up.*



Start-Up and Shutdown

Important: Initial unit commissioning start-up must be performed by Trane or an agent of Trane specifically authorized to perform start-up and warranty of Trane products. Contractor shall provide Trane (or an agent of Trane specifically authorized to perform start-up) with notice of the scheduled start-up at least two weeks prior to the scheduled start-up.

Unit Start-Up

NOTICE:

Equipment Damage!

Ensure that the compressor and oil sump heaters have been operating properly for a minimum of 24 hours before starting. Failure to do so could result in equipment damage.

If required, once the system has been operating for approximately 30 minutes and has become stabilized, complete the remaining start-up procedures, as follows:

1. Check evaporator and condenser refrigerant pressures under Refrigerant Report on the AdaptiView™ TD7. The pressures are referenced to sea level (14.6960 psia).
2. Check EXV sight glasses after sufficient time has elapsed to stabilize the chiller. The refrigerant flow past sight glasses should be clear. Bubbles in the refrigerant indicate either low refrigerant charge or excessive pressure drop in the liquid line or a stuck open expansion valve. A restriction in the line can sometimes be identified by a noticeable temperature differential between the two sides of the restriction. Frost will often form on the line at this point. See [“General Information,” p. 9](#) for proper refrigerant charges.

Important: A clear sight glass alone does not mean that the system is properly charged. Also check system subcooling, liquid level control and unit operating pressures.

If chiller is limited by any limiting conditions, contact local Trane service organization for more information.

Temporary Shutdown And Restart

To shut down for a short time, use the following procedure:

1. Press the STOP key on the Adaptiview TD7. The compressors will continue to operate and an operational pumpdown cycle will be initiated.
2. UC800 pump control will turn off the pump (after a minimum 1 min. delay) when the STOP key is pressed and automatically restart the pump when the unit starts normally.

3. The unit will start normally, provided the following conditions exist:
 - a. The UC800 receives a call for cooling and the differential-to-start is above the setpoint.
 - b. All system operating interlocks and safety circuits are satisfied.

Extended Unit Shutdown

4. Perform the normal unit stop sequence using the <Stop> key.

Note: Do not open starter disconnect switch. This must remain closed to provide control power from the control power transformer to the oil sump heater.

5. Verify chilled water and condenser water pumps are cycled off. If desired, open disconnect switches to the pumps.
6. Drain condenser piping and cooling tower, if desired.
7. Remove the drain and vent plugs from the condenser headers to drain the condenser.
8. Verify that the Crank Case heater is working.
9. Once the unit is secured, perform the maintenance identified in the following sections.

Seasonal Unit Start-Up Procedure

1. Close all valves and re-install the drain plugs in the evaporator and condenser heads.
2. Service the auxiliary equipment according to the start-up/maintenance instructions provided by the respective equipment manufacturers.
3. Vent and fill the cooling tower, if used, as well as the condenser and piping. At this point, all air must be removed from the system (including each pass). Close the vents in the evaporator chilled water circuits.
4. Open all valves in the evaporator chilled water circuits.
5. If the evaporator was previously drained, vent and fill the evaporator and chilled water circuit. When all air is removed from the system (including each pass), install the vent plugs in the evaporator water boxes.

NOTICE:

Equipment Damage!

Ensure that the oil sump heaters have been operating for a minimum of 24 hours before starting. Failure to do so may result in equipment damage.

6. Check the adjustment and operation of each safety and operating control.
7. Close all disconnect switches.
8. Refer to the sequence for daily unit startup for the remainder of the seasonal startup

Sequence of Operation

This section will provide basic information on chiller operation for common events. With microelectronic controls, ladder diagrams cannot show today's complex logic, as the control functions are much more involved than older pneumatic or solid state controls.

Adaptive control algorithms can also complicate the exact sequence of operations. This section illustrates common control sequences.

Software Operation Overview

The Software Operation Overview shown in Figure 51 is a diagram of the five possible software states. This diagram can be thought of as a state chart, with the arrows and arrow text depicting the transitions between states.

Figure 51. Software operation overview

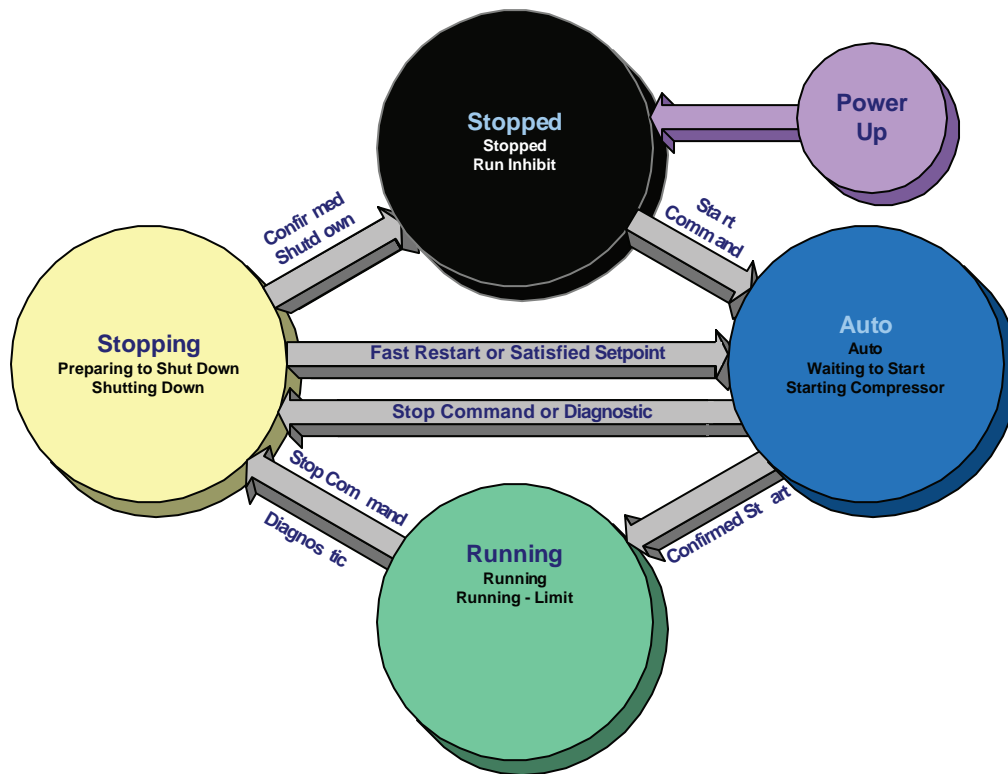

- The text in the circles is the visible top level operating mode displayed on Tracer™ AdaptiView.
- The shading of each software state circle corresponds to the shading on the time lines that show the state the chiller is in.

There are five generic states that the software can be in:

- Power Up
- Stopped
- Starting
- Running
- Stopping

Timelines

- The time line indicates the upper level operating mode, as it would be viewed on the Tracer AdaptiView™.
- The shading color of the cylinder indicates the software state.
- Text in parentheses indicates sub-mode text as viewed on Tracer AdaptiView™.
- Text above the time line cylinder is used to illustrate inputs to the Main Processor. This may include user input to the Tracer AdaptiView™ Touch screen, control inputs from sensors, or control inputs from a Generic BAS.
- Boxes indicate control actions such as turning on relays, or pulsing compressor load or unload solenoids.
- Smaller cylinders under the main cylinder indicate diagnostic checks.
- Text outside a box or cylinder indicates time based functions.
- Solid double arrows indicate fixed timers.
- Dashed double arrows indicate variable timers.

Power Up

The Power up chart shows the respective TD7 screens during a power up of the main processor. This process takes from 30 to 50 seconds depending on the number of installed Options. On all power ups, the software model will always transition through the 'Stopped' Software

state independent of the last mode. If the last mode before power down was 'Auto', the transition from 'Stopped' to 'Starting' occurs, but it is not apparent to the user.

Figure 52. Sequence of events: power up diagram

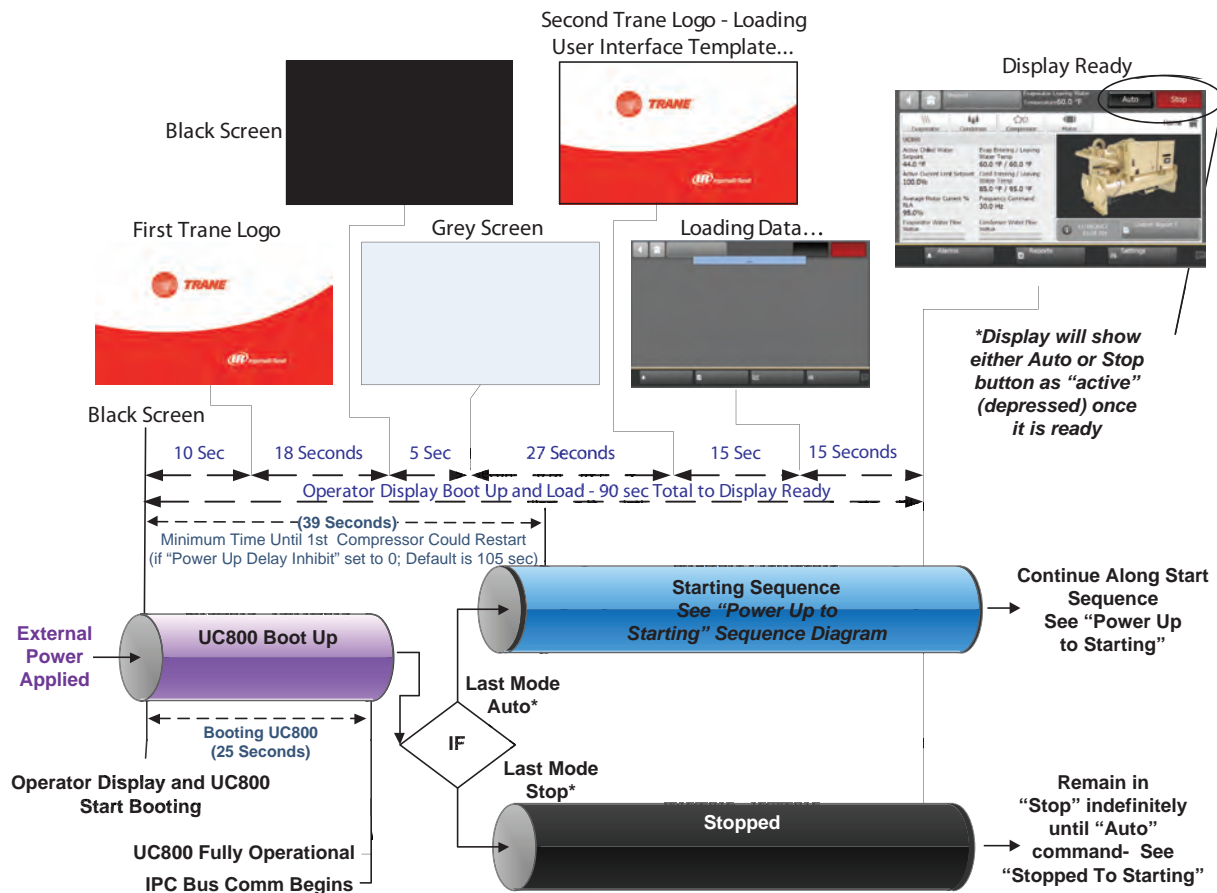

Figure 53. Sequence of events: TD7 screen displays



Start-Up and Shutdown

Power Up to Starting

The Power up to starting diagram shows the timing from a power up event to energizing the compressor. The shortest allowable time would be under the following conditions:

- No motor restart inhibit
- Evaporator and Condenser Water flowing

- Power up Start Delay setpoint set to 0 minutes
- Adjustable Stop to Start Timer set to 5 seconds
- Need to cool

The above conditions would allow for a minimum power up to starting compressor time of 95 seconds.

Figure 54. Sequence of events: power up to starting

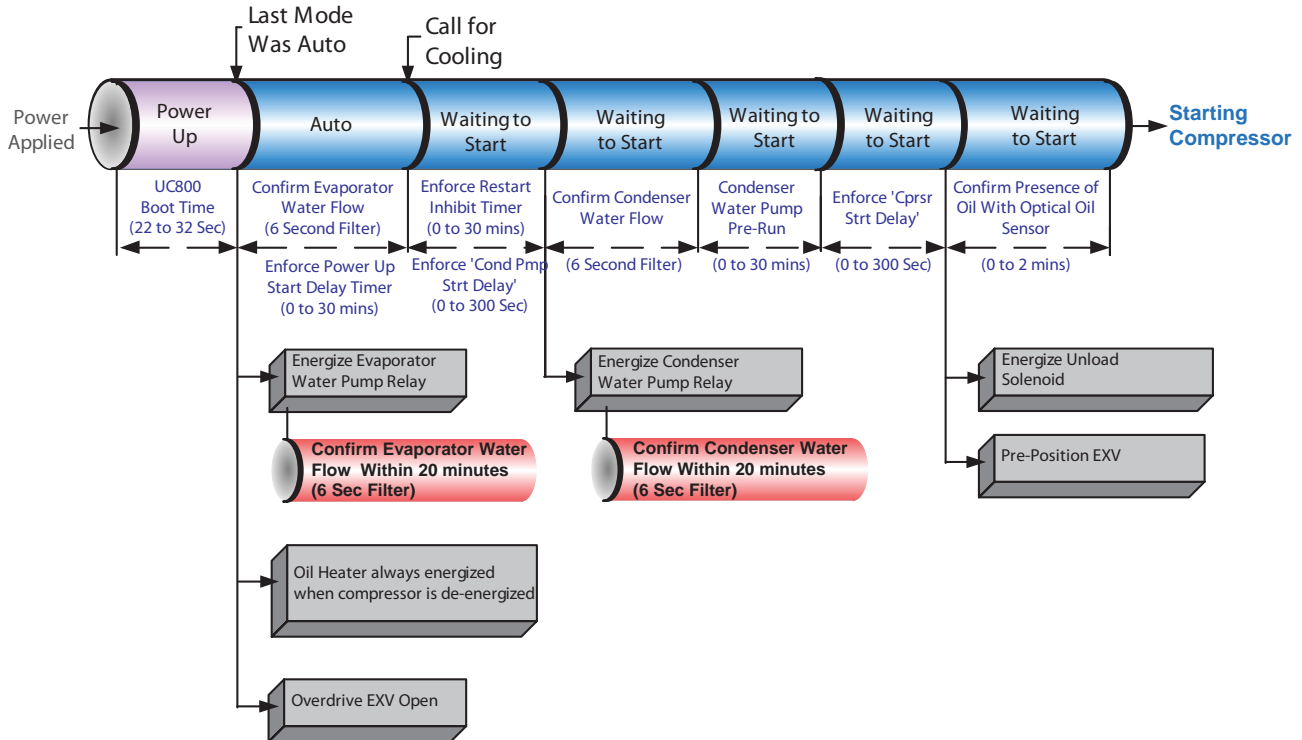

Stopped to Starting

The stopped to starting diagram shows the timing from a stopped mode to energizing the compressor. The shortest allowable time would be under the following conditions:

- No motor restart inhibit
- Evaporator and Condenser Water flowing

- Power up Start Delay Timer has expired
- Adjustable Stop to Start Timer has expired
- Need to cool

The above conditions would allow the compressor to start in 60 seconds.

Figure 55. Sequence of events: stopped to starting

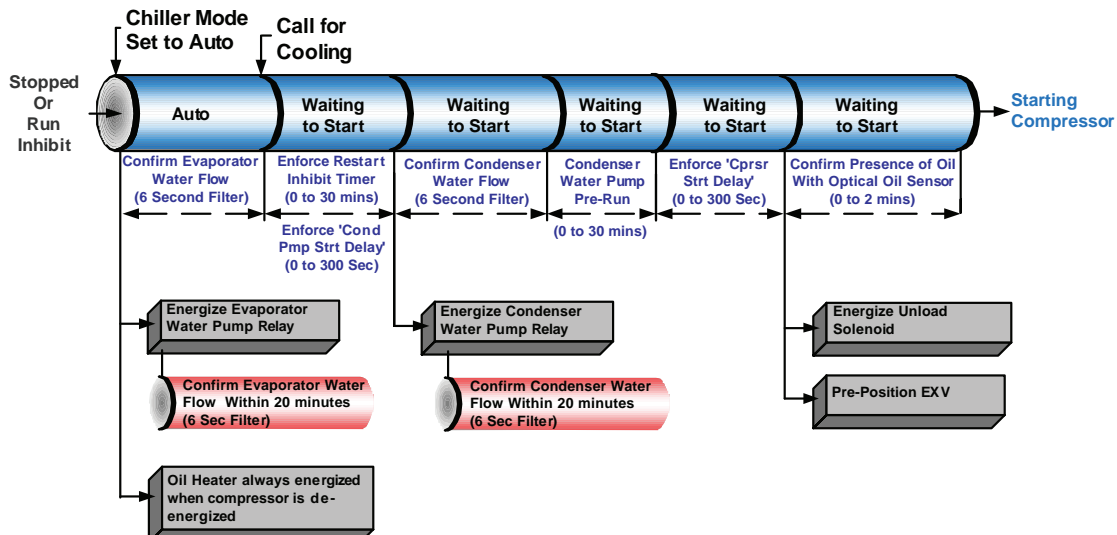

Starting Wye-Delta

The Starting Wye-Delta shows the order of operation for this type of starter.

Figure 56. Sequence of events: Starting wye-delta

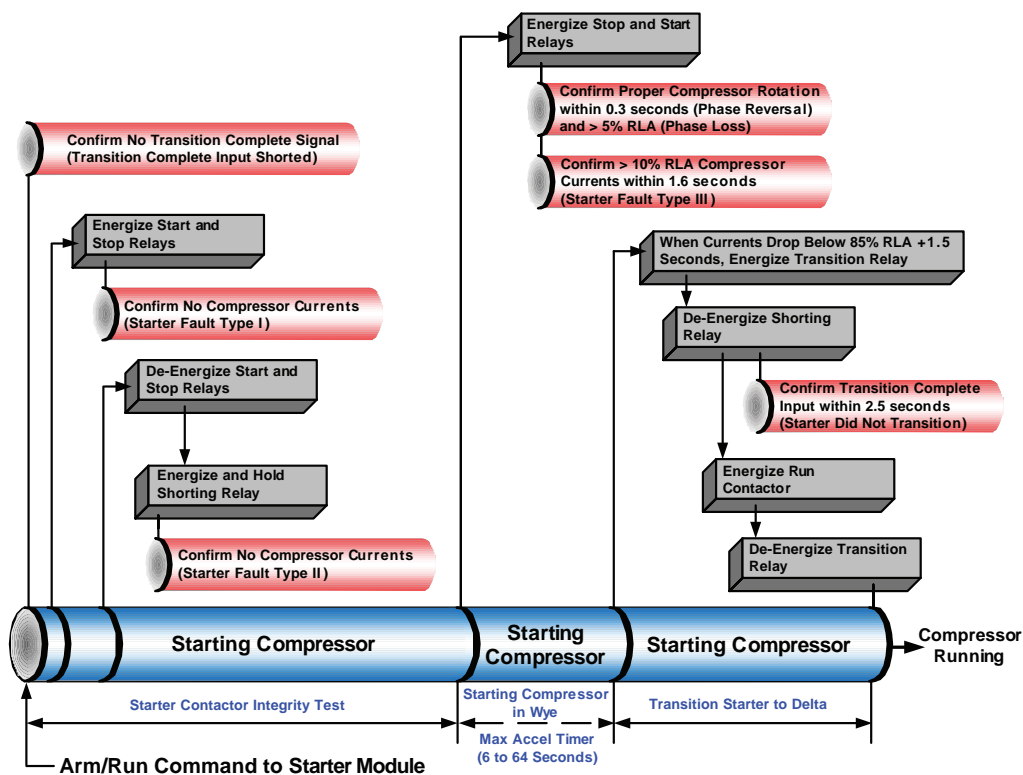

Starting AFD

The Starting AFD shows the order of operation for this type of starter.

Figure 57. Sequence of events: starting AFD

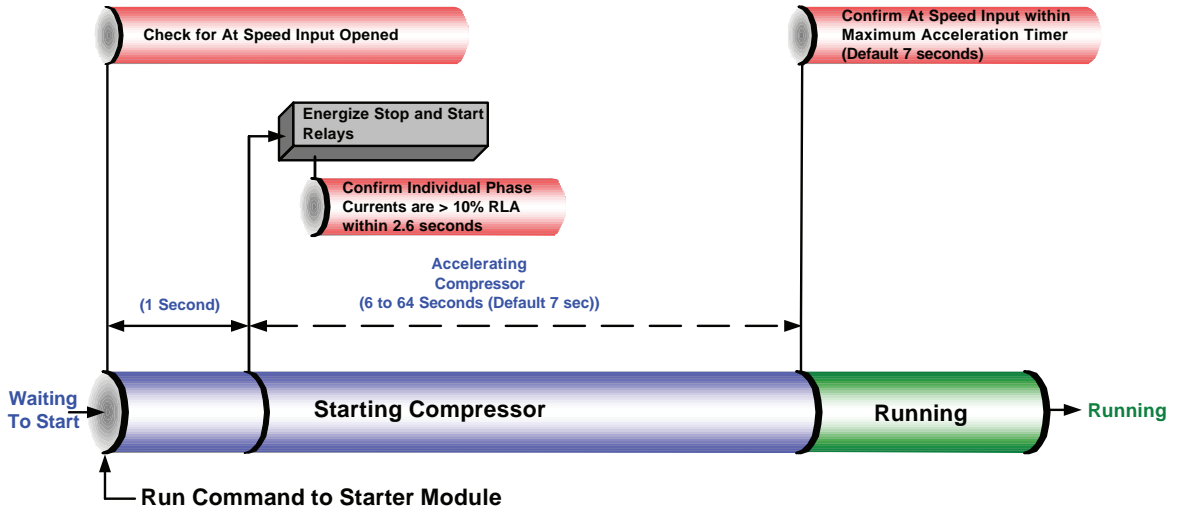

Running

The Running Diagram shows a typical running sequence.

Figure 58. Sequence of events: running

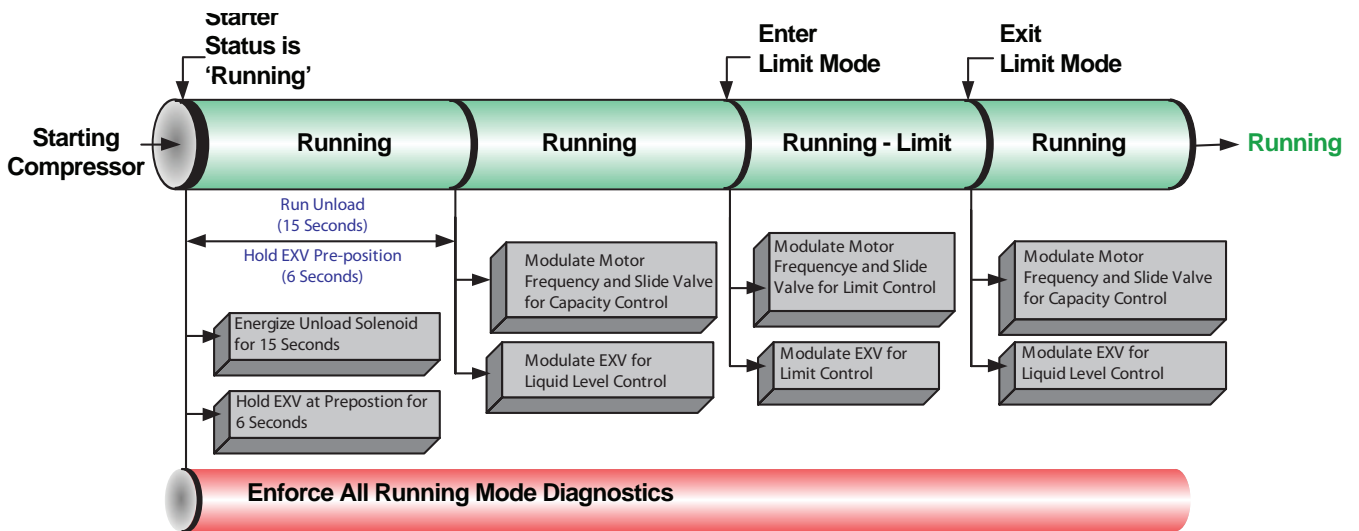

Satisfied Setpoint

The Satisfied Setpoint diagram shows the normal transition from Running to shutting down due to the Evap Leaving water temp falling below the differential to stop setpoint.

Figure 59. Sequence of events: satisfied setpoint

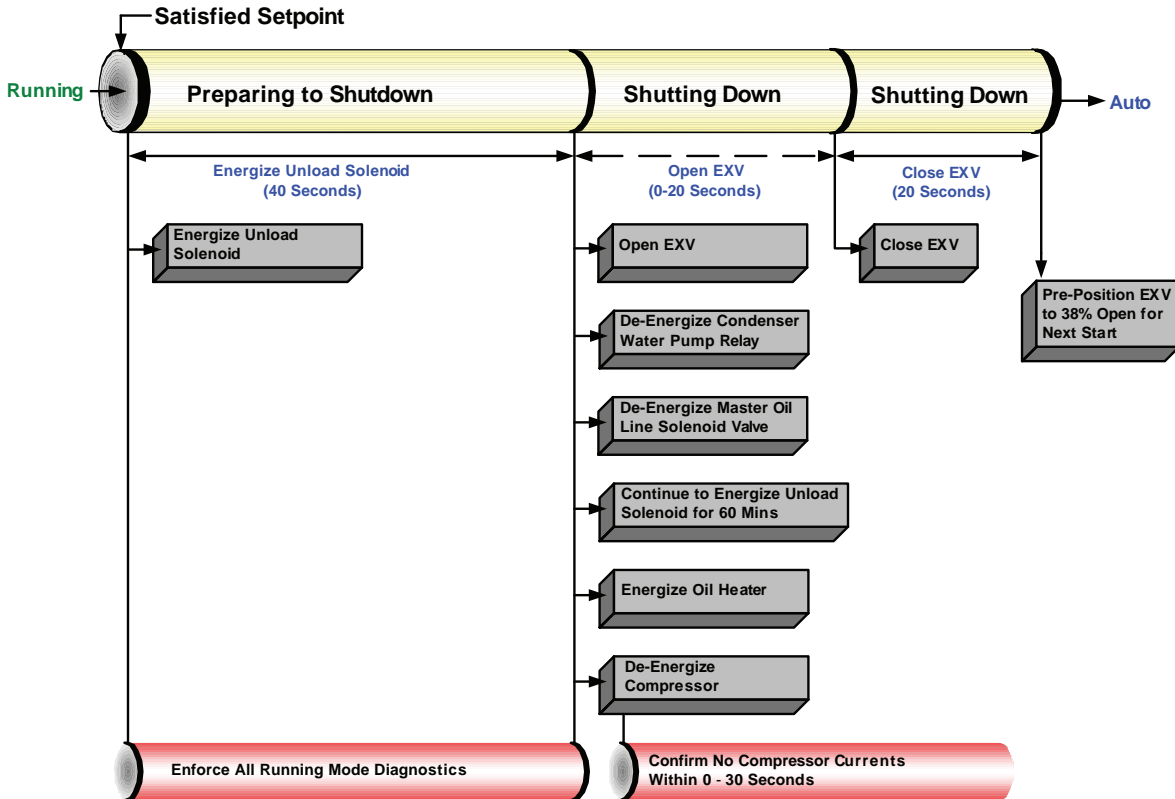

Normal Shutdown to Stopped or Run Inhibit

The Normal Shutdown diagram shows the Transition from Running through a Normal (friendly) Shutdown. The Dashed lines on the top attempt to show the final mode if you enter the stop via various inputs.

Figure 60. Sequence of events: normal shutdown to stopped or run inhibit

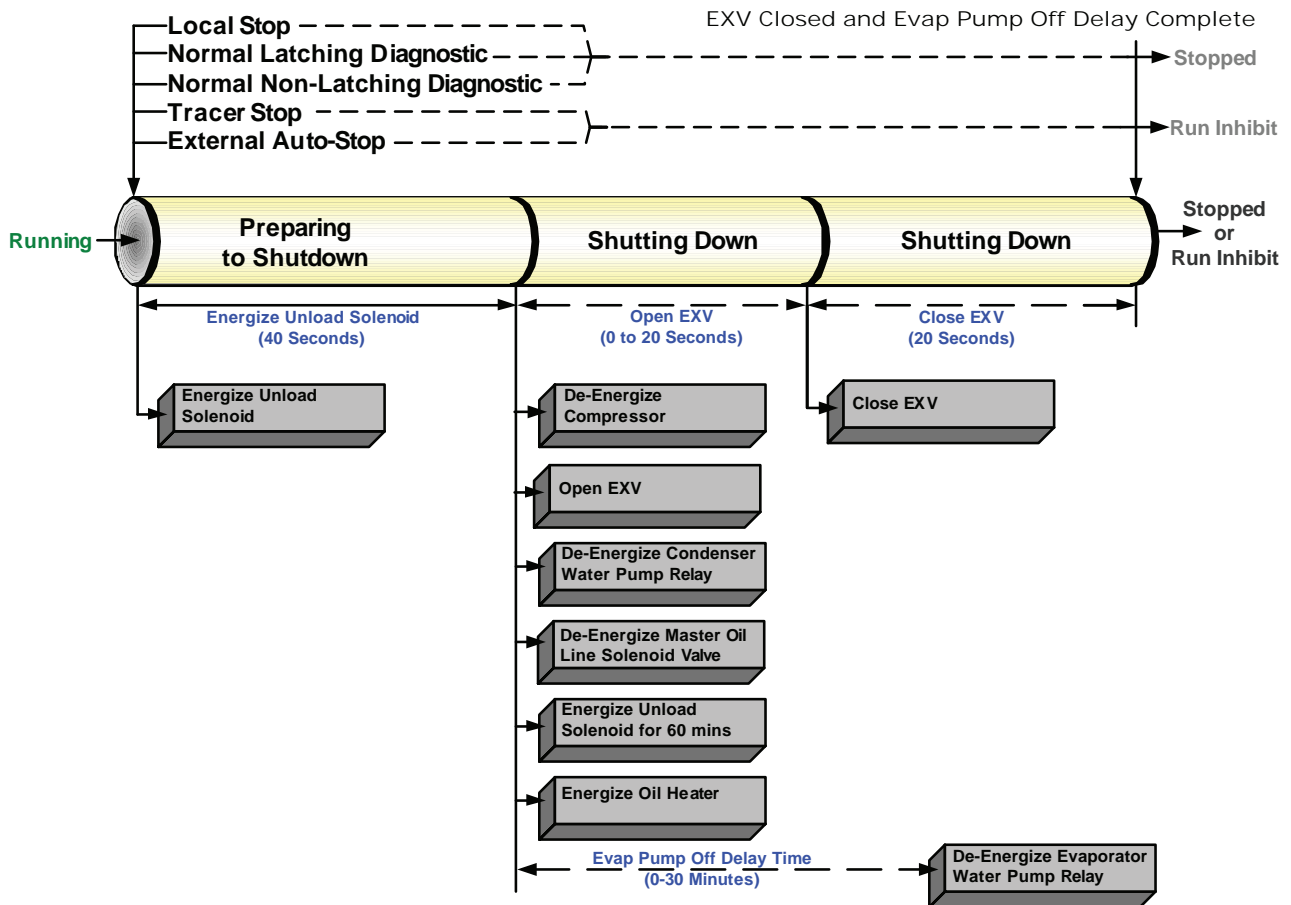

Immediate Shutdown to Stopped or Run Inhibit

The Immediate Shutdown diagram shows the Transition from Running through an Immediate Shutdown. The Dashed lines on the top attempt to show the final mode if you enter the stop via various inputs.

Figure 61. Sequence of events: immediate shutdown to stopped or run inhibit

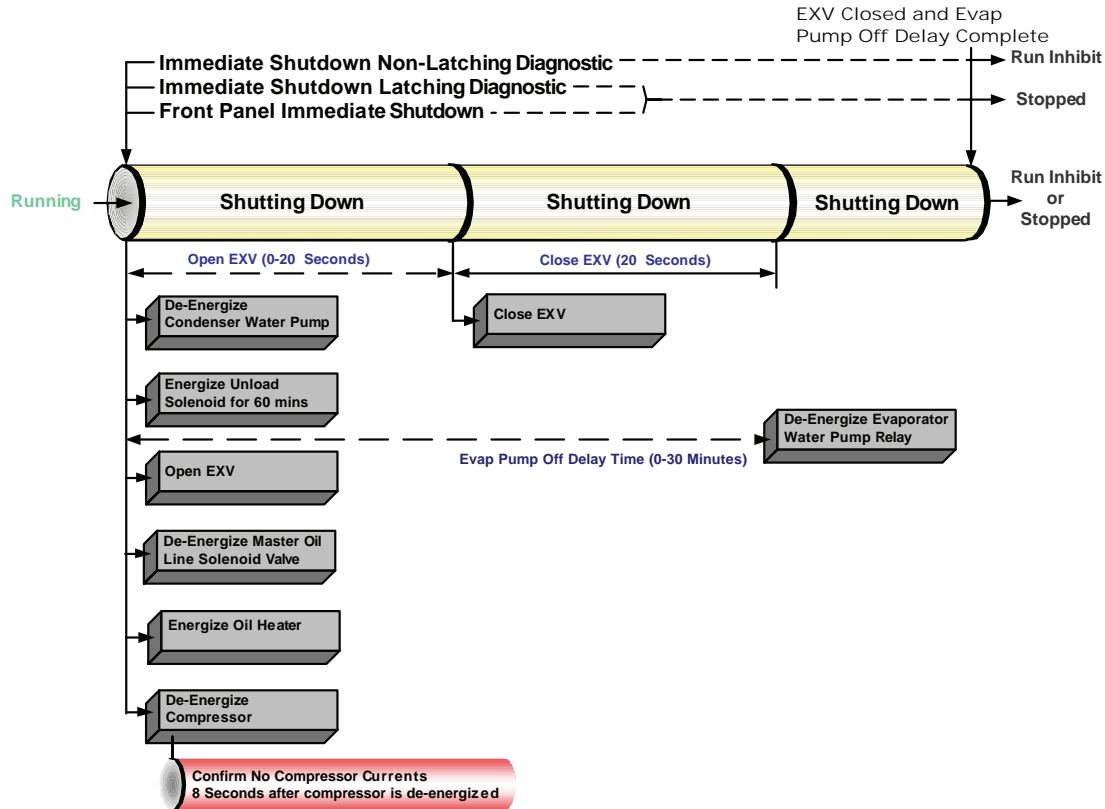

Momentary Power Loss

The Momentary Power Loss diagram shows how the controls act in a power interruption event that the controls diagnose as a MPL diagnostic.

Figure 62. Sequence of events: momentary power loss

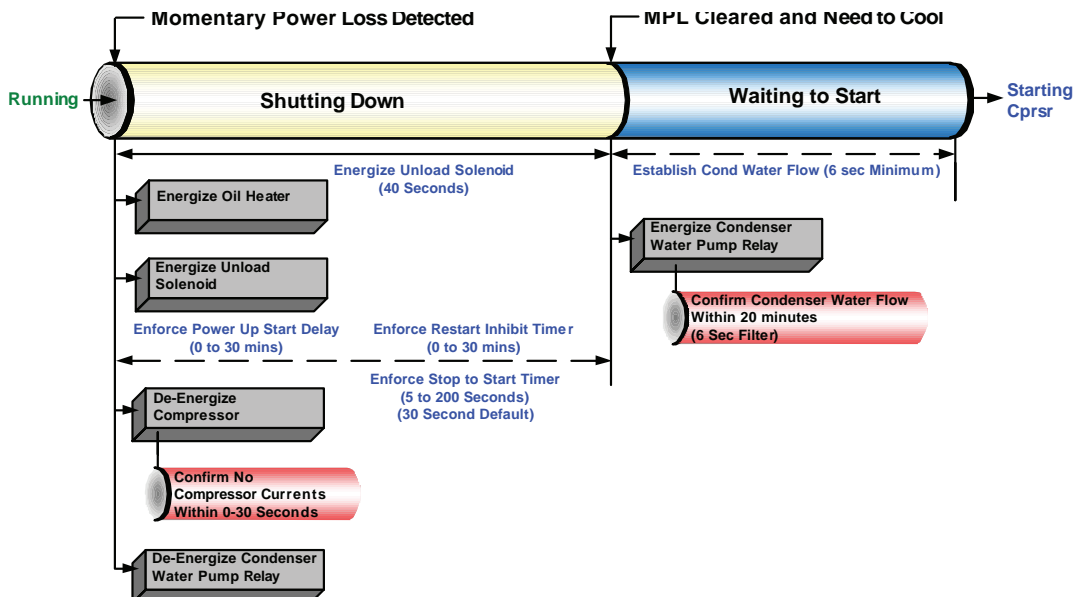

Ice Making (Running to Ice Making to Running)

This diagram show the transition from normal cooling to Ice making, back to normal cooling

Figure 63. Sequence of events: ice making (running to ice making to running)

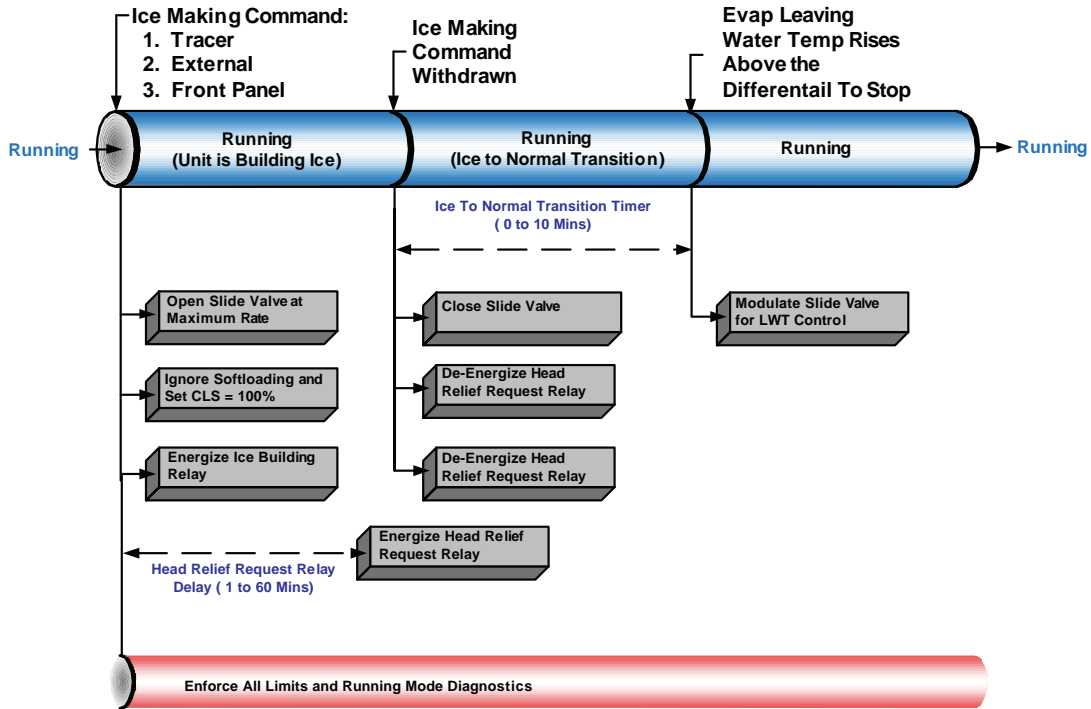

Ice Making (Auto to Ice Making to Ice Making Complete)

This diagram shows the transition from Auto to Ice making, to Ice Making Complete

Figure 64. Sequence of events: ice making (auto to ice making to ice making complete)

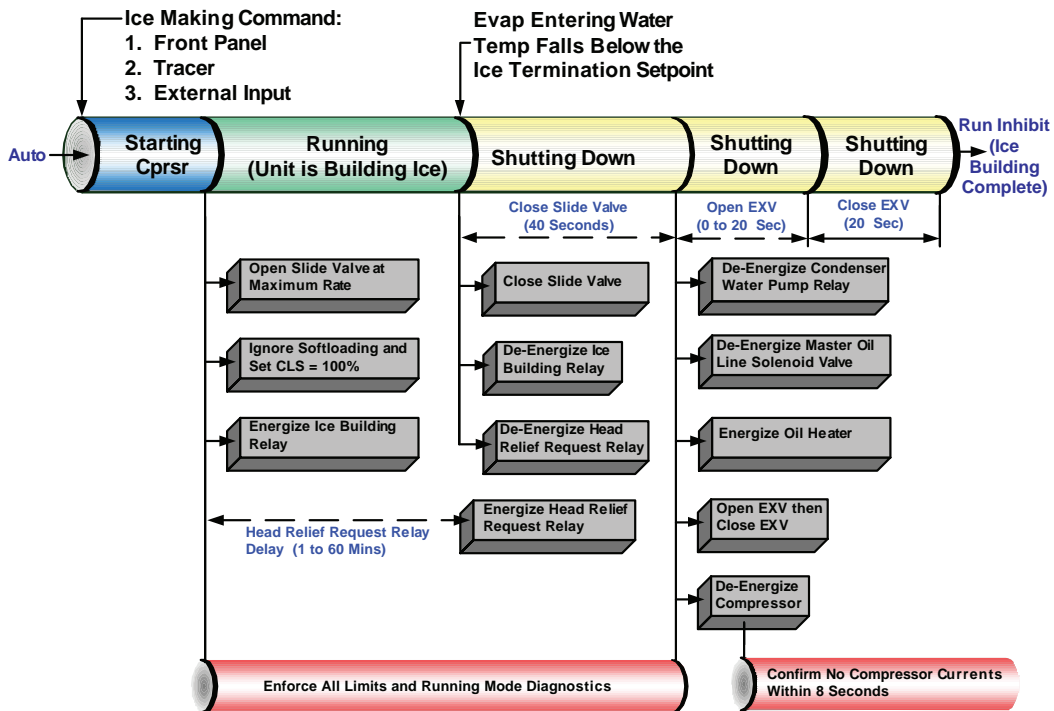

No Load Start

This diagram shows a pre-start sequence with the Start Sequence Type set to 'No Load'.

Figure 65. Sequence of events: no load start

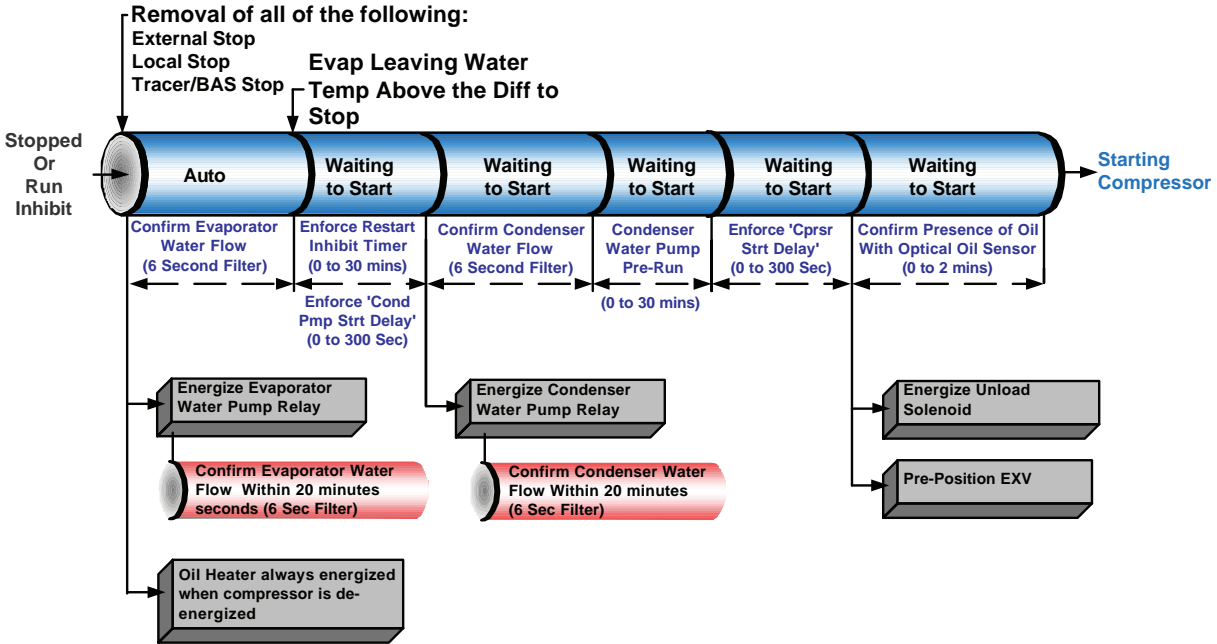

Limit Conditions

UC800 will automatically limit certain operating parameters during startup and run modes to maintain optimum chiller performance and prevent nuisance diagnostic trips. These limit conditions are noted in [Table 28](#).

Table 28. Limit conditions

Condition	Description
Running- limited	The chiller, circuit, and compressor are currently running, but the operation of the chiller/compressor is being actively limited by the controls. Further information is provided by the sub-mode.
Condenser Pressure Limit	The circuit is experiencing condenser pressures at or near the condenser limit setting. The compressor will be unloaded to prevent exceeding the limits.
Low Evaporator Refrigerant Temperature Inhibit	The circuit is experiencing saturated evaporator temperatures at or near the Low Refrigerant Temperature Cutout setting. The compressors will be unloaded to prevent tripping.
Capacity Limited by Low Liquid Level	The circuit is experiencing low refrigerant liquid levels and the EXV is at or near full open. The compressor will be unloaded to prevent tripping.
Current Limit	The compressor is running and its capacity is being limited by high currents. The current limit setting is 100% RLA (to avoid overcurrent trips).
Phase Unbalance Limit	The compressor is running and its capacity is being limited by excessive phase current unbalance.



Maintenance

⚠ WARNING

Hazardous Voltage w/Capacitors!

Failure to disconnect power and discharge capacitors before servicing could result in death or serious injury. Disconnect all electric power, including remote disconnects before servicing. Follow proper lockout/tagout procedures to ensure the power cannot be inadvertently energized. For variable frequency drives or other energy storing components provided by Trane or others, refer to the appropriate manufacturer's literature for allowable waiting periods for discharge of capacitors. Verify with an appropriate voltmeter that all capacitors have discharged.

For additional information regarding the safe discharge of capacitors, see PROD-SVB06A-EN.

This section describes the basic chiller preventive maintenance procedures, and recommends the intervals at which these procedures should be performed. Use of a periodic maintenance program is important to ensure the best possible performance and efficiency from a Stealth™ chiller.

Use an Operator Log (see “Log and Check Sheets,” p. 95) to record an operating history for unit. The log serves as a valuable diagnostic tool for service personnel. By observing trends in operating conditions, an operator can anticipate and prevent problem situations before they occur.

If unit does not operate properly during inspections, see “Diagnostics,” p. 83.

Recommended Maintenance

Weekly

While the unit is running in stable conditions:

- Log the chiller.
- Check evaporator and condenser pressures with gauges and compare to the reading on the Tracer AdaptiView™ TD7 or Tracer® TU service too. Pressure readings should fall within operating ranges specified in Table 29 and Table 30, p. 79. If chiller measurements vary significantly from values listed in Table 29 and Table 30, p. 79, problems may exist with refrigerant and oil charge levels. Contact local Trane service.

Note: Optimum condenser pressure is dependent on condenser water temperature, and should equal saturation pressure of refrigerant at a temperature 2 to 5°F above that of leaving condenser water at full load.

Monthly

- Review operating log.

- Clean all water strainers in both the chilled and condensing water piping systems.
- Measure and log the subcooling and superheat.
- See “Refrigerant and Oil Charge Management,” p. 78. If chiller measurements vary significantly from values listed in Table 29 and Table 30, p. 79, problems may exist with refrigerant and oil charge levels. Contact local Trane service.

Annual

Shut down the chiller once each year to check the following:

- Perform all weekly and monthly maintenance procedures.
- Have a qualified laboratory perform an oil analysis to determine system moisture content and acid level.

Important: Due to the hygroscopic properties of the POE oil, all oil must be stored in metal containers. The oil will absorb water if stored in a plastic container.

- Contact Trane service to leak check the chiller, inspect safety controls, and inspect electrical components for deficiencies.
- Inspect all piping components for leakage and/or damage. Clean out any in-line strainers.
- Clean and repaint any areas that show signs of corrosion.
- Inspect vent piping of all relief valves for presence of refrigerant to detect improperly sealed relief valves. Contact Trane service if unusual conditions are observed.
- Inspect the condenser tubes for fouling. Clean if necessary. See “Cleaning the Condenser,” p. 79.
- Check to make sure that the oil sump heater is working.

Scheduling Other Maintenance

- Use a nondestructive tube test to inspect the condenser and evaporator tubes at 3-year intervals.
- Note:** It may be desirable to perform tube tests on these components at more frequent intervals, depending upon chiller application. This is especially true of critical process equipment.
- Depending on chiller duty, contact Trane service organization to determine when to conduct a complete examination of the unit to determine the condition of the compressor and internal components.

Refrigerant and Oil Charge Management

Proper oil and refrigerant charge is essential for proper unit operation, unit performance, and environmental protection. Only trained and licensed service personnel should service the chiller.

Table 29 and Table 30 list baseline measurements for Optimus™ units running at AHRI standard operating conditions. If chiller measurements vary significantly from values listed below, problems may exist with refrigerant and oil charge levels. Contact Trane service.

Table 29. Operating conditions at full load^(a)

Description	Condition
Evaporator pressure	40-55 psig
Condensing pressure	85-120 psig
Discharge superheat	17°F
Subcooling	5-10°F
EXV percent open	40-50% open in Auto mode

(a) All conditions stated above are based on the unit running fully loaded at AHRI conditions. If full load conditions cannot be met, contact Trane service.

Table 30. Operating conditions at minimum load^(a)

Description	Condition
Evaporator approach	*less than 7°F (non-glycol applications)
Condensing approach	*less than 7°F
Subcooling	2-3°F
EXV percent open	10-20 % open

* \cong 1.0°F for new unit.

(a) Conditions at minimum must be: entering condenser water: 85°F and entering evaporator water: 55°F

Maintenance Procedures

Cleaning the Condenser

NOTICE:

Proper Water Treatment!

The use of untreated or improperly treated water could result in scaling, erosion, corrosion, algae or slime. It is recommended that the services of a qualified water treatment specialist be engaged to determine what water treatment, if any, is required. Trane assumes no responsibility for equipment failures which result from untreated or improperly treated water, or saline or brackish water.

Condenser tube fouling is suspect when the “approach” temperature (i.e., the difference between the refrigerant condensing temperature and the leaving condenser water temperature) is higher than predicted.

Standard water applications will operate with less than a 10°F approach. If the approach exceeds 10°F, cleaning the condenser tubes is recommended.

Note: Glycol in the water system typically doubles the standard approach.

If the annual condenser tube inspection indicates that the tubes are fouled, two cleaning methods can be used to rid the tubes of contaminants. The methods are:

Mechanical Cleaning Procedure

Mechanical tube cleaning this method is used to remove sludge and loose material from smooth-bore condenser tubes.

⚠ WARNING

Heavy Objects!

Failure to properly lift waterbox could result in death or serious injury. Each of the individual cables (chains or slings) used to lift the waterbox must be capable of supporting the entire weight of the waterbox. The cables (chains or slings) must be rated for overhead lifting applications with an acceptable working load limit.

⚠ WARNING

Heavy Objects!

Failure to properly lift waterbox could result in death or serious injury. The proper use and ratings for eyebolts can be found in ANSI/ASME standard B18.15. Maximum load rating for eyebolts are based on a straight vertical lift in a gradually increasing manner. Angular lifts will significantly lower maximum loads and should be avoided whenever possible. Loads should always be applied to eyebolts in the plane of the eye, not at some angle to this plane.

Waterbox Removal. Review mechanical room limitations and determine the safest method or methods of rigging and lifting the waterboxes.

Important:

- Do not rotate water boxes. See Figure 14, p. 32 through Figure 16, p. 32 for correct orientation of the water inlet and outlet.
 - Be certain to replace water boxes right-side-up to maintain proper baffle orientation. Use new o-rings.
1. Determine the size of chiller being serviced. See unit nameplate located on chiller control panel.
 2. Select the proper lift connection device from Table 33, p. 80. The rated lifting capacity of the selected lift connection device must meet or exceed the published weight of the waterbox found in Table 32, p. 80.
 3. Ensure the lift connection device has the correct connection for the waterbox. Example: thread type (course/fine, English/metric). Bolt diameter (English/metric).
 4. Properly connect the lift connection device to the waterbox. See Figure 66. Ensure lift connection device is securely fastened.
 5. Install hoist ring on to the lifting connection on the waterbox. Torque to 28 ft-lbs (37 Nm).

Figure 66. Waterbox lifting

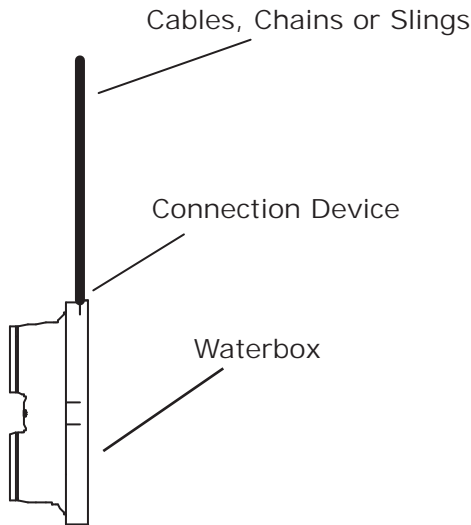

6. Disconnect water pipes, if connected.
7. Remove waterbox bolts
8. Lift the waterbox away from the shell.

⚠ WARNING

Overhead Hazard!
 Failure to follow these instructions could result in death or serious injuries. Never stand below or in close proximity to heavy objects while they are suspended from, or being lifted by, a lifting device. Do not leave waterbox suspended from lifting device.

9. Store waterbox in a safe and secure location and position.
10. Work a round nylon or brass bristled brush (attached to a rod) in and out of each of the condenser water tubes to loosen the sludge.
11. Thoroughly flush the condenser water tubes with clean water.

Note: To clean internally enhanced tubes, use a bi-directional brush or consult a qualified service organization for recommendations.

Reassembly. Once service is complete the waterbox should be reinstalled on the shell following all previous procedures in reverse. Use new o-rings or gaskets on all joints after thoroughly cleaning each joint.

- Torque waterbox bolt in a star pattern. See Table 31 for torque values.

Table 31. RTHD Torque

Evaporator	Condenser
65 ft-lbs (88 Nm)	65 ft-lbs (88 Nm)

Table 32. Waterbox weights

Waterbox	Size ^(a)	Number of Water Passes	Weight kg (lbs)	
			Standard Grooved Pipe Waterbox ^(b)	Marine Style Waterbox ^(c)
Evaporator	G	4	164 (361)	NA
	G	3	208 (458)	NA
	F	3	107 (235)	NA
	F	2	107 (235)	NA
	D/E	3	91 (201)	NA
	D/E	2	110 (243)	NA
	B/C	3	76 (167)	NA
	B/C	2	91 (201)	NA
	B/C	2	73 (160)	NA
Condenser	G	2	102 (226)	297 (655)
	E/F	2	66 (146)	239 (526)
	B/D	2	53 (116)	187 (412)

(a) Evaporator size is Digit 14 in the model number. Condenser is Digit 21 in model number.
 (b) Lifting connection size M12x1.75.
 (c) Lifting connection is a lifting lug. Removable cover has a weight of 138 kg (300 lbs). Lifting lug connection is M12x1.75.

Table 33. Connection devices

Unit	Product	Part Number
RTHD	Safety Hoist Ring M12x1.75	RNG01886

Obtain the required parts from your local Trane Parts Center.

Chemical Cleaning Procedure

- Scale deposits are best removed by chemical means. Consult a qualified water treatment specialist (i.e., one that knows the local water supply chemical/mineral content) for a recommended cleaning solution suitable for the job. (A standard condenser water circuit is composed solely of copper, cast iron and steel.) Improper chemical cleaning can damage tube walls.

All of the materials used in the external circulation system, the quantity of the solution, the duration of the cleaning period, and any required safety precautions should be approved by the company furnishing the materials or performing the cleaning.

Note: Chemical tube cleaning should always be followed by mechanical tube cleaning.

Cleaning the Evaporator

Since the evaporator is typically part of a closed circuit, it does not accumulate appreciable amounts of scale or sludge. However, if cleaning is deemed necessary, use the same cleaning methods described for the condenser tubes.

Oil Sump Level Check

Running the chiller at minimum load is the best for the quickest return of oil to the separator and sump. The machine still needs to sit for approximately 30 minutes before the level is taken. At minimum load, the discharge superheat should be highest. The more heat in the oil as it lays in the sump, the more refrigerant will boil off in the sump and leave more concentrated oil.

The oil level in the oil sump can be measured to give an indication of the system oil charge. Follow the procedures below to measure the level.

1. Run the unit fully unloaded for approximately 20 minutes.
2. Cycle the compressor off line.

NOTICE:

Equipment Damage!

Never operate the compressor with the sightglass service valves opened. Severe oil loss will occur. Close the valves after checking the oil level. The sump is above the condenser and it is possible to drain the oil.

Figure 67. Determining oil level in sump

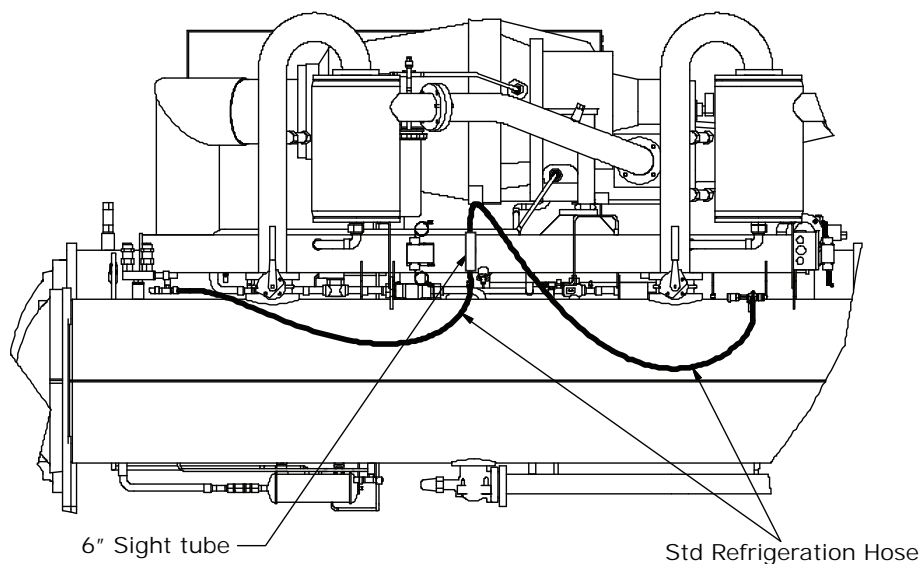

3. Attach standard refrigeration hose with a sight tube in the middle to the oil sump drain valve and the condenser service valve at the top of the condenser. Using high pressure rated clear hose with appropriate fittings can help speed up the process.

Note: A shutoff valve at one end of the hose is recommended to facilitate hose drainage after oil level check is completed.

4. After the unit is off line for 30 minutes, move the sightglass along the side of the oil sump.
5. The level should be between 2" and 5" from the bottom of the oil sump.

Note: If oil levels are not between 2" and 5", contact Trane service.

Optional AFD Periodic Maintenance and Inspection

AFD periodic maintenance and inspections should be performed every 1–12 months, depending on operating environment.

Visual Inspection — Power Removed

⚠ WARNING

Hazardous Voltage w/Capacitors!

Failure to disconnect power and discharge capacitors before servicing could result in death or serious injury. Disconnect all electric power, including remote disconnects and discharge all motor start/run capacitors before servicing. Follow proper lockout/tagout procedures to ensure the power cannot be inadvertently energized. For variable frequency drives or other energy storing components provided by Trane or others, refer to the appropriate manufacturer's literature for allowable waiting periods for discharge of capacitors. Verify with an appropriate voltmeter that all capacitors have discharged.

For additional information regarding the safe discharge of capacitors, see PROD-SVB06A-EN.

1. Ensure the door interlocks are present and working.
2. Verify the safety ground connections to the door panels are securely connected.
3. Inspect power wire cables and devices to assure no abrasion is occurring from vibrations against chassis of cabinets, or other edges.
4. Ensure the drive interior and exterior is clear of any dust or debris. Fans, circuit boards, vents etc. must be clean.

Important: Only use a vacuum for cleaning. *DO NOT use compressed air.*

5. Inspect the interior of the drive for any signs of moisture entry or leakage.
6. Visually inspect all drive components and wiring. Look for signs of heat or failure (look for swelled or leaking capacitors, discolored reactors or inductors, broken pre-charge resistors, smoke or arc trails on MOVs and capacitors, etc.).
7. Closely inspect the motor terminal board for any signs of leakage, arcing, etc.
8. Check ALL cable/lug/terminal connections inside the drive enclosure. Ensure all are clean and tight, and not rubbing against each other anywhere.

Operational Inspection — Power Applied

⚠ WARNING

Live Electrical Components!

Failure to follow all electrical safety precautions when exposed to live electrical components could result in death or serious injury. When necessary to work with live electrical components, have a qualified licensed electrician or other individual who has been properly trained in handling live electrical components perform these tasks.

1. Verify the drive cabinet cooling fans are operating. This should be done from outside the enclosure, by looking into the cabinet at door and cabinet vents, to avoid electrical hazards.
Note: *The power module fan comes on with power. Other fans cycle with drive operation.*
2. Check historic fault codes using AFD control panel (LCP).
Note: *The AFD control panel is used ONLY for service and should never be used for machine operation.*
3. Check configuration settings and confirm all proper settings are still present in the controls.
4. Review the diagnostic history.
5. Make Chiller Service report to document all setpoints.
6. Check the UC800 alarm histories for any indications of operational problems.

Choke Inspection

As needed, replace the magnetic choke if there is physical damage (for example, cracks).



Diagnostics

Diagnostic Name and Source: Name of Diagnostic and its source. Note that this is the exact text used in the User Interface and/or Service Tool displays.

Affects Target: Defines the “target” or what is affected by the diagnostic. Usually either the entire Chiller, or a particular Circuit or Compressor is affected by the diagnostic (the same one as the source), but in special cases functions are modified or disabled by the diagnostic. None implies that there is no direct affect to the chiller, sub components or functional operation.

Note: *Tracer® TU does not support the display of certain targets on its Diagnostics pages although the functionality implied by this table is supported. Targets such as Evap Pump, Ice Mode, Heat Mode, Chilled Water Reset, External Setpoints etc. – are displayed as simply “Chiller” even though they do not imply a chiller shutdown – only a compromise of the specific feature.*

Severity: Defines the severity of the above effect. Immediate means immediate shutdown of the affected portion, Normal means normal or friendly shutdown of the affected portion, Special Action means a special action or mode of operation (limp along) is invoked, but without shutdown, and Info means an Informational Note or Warning is generated. Design Note: Tracer® TU does not support display of “Special Action”; on its Diagnostics pages, so that if a diagnostic has a special action defined

in the table below, it will be displayed only as “Informational Warning” as long as no circuit or chiller shutdown results. If there is a shutdown and special action defined in the table, then the Tracer® TU Diagnostics Page display will indicate the shutdown type only.

Persistence: Defines whether or not the diagnostic and its effects are to be manually reset (Latched), or can be either manually or automatically reset when and if the condition returns to normal (Nonlatched).

Active Modes [Inactive Modes]: States the modes or periods of operation that the diagnostic is active in and, as necessary, those modes or periods that it is specifically “not active” in as an exception to the active modes. The inactive modes are enclosed in brackets, []. Note that the modes used in this column are internal and not generally announced to any of the formal mode displays.

Criteria: Quantitatively defines the criteria used in generating the diagnostic and, if nonlatching, the criteria for auto reset.

Reset Level: Defines the lowest level of manual diagnostic reset command which can clear the diagnostic. The manual diagnostic reset levels in order of priority are: Local or Remote. For example, a diagnostic that has a reset level of Remote, can be reset by either a remote diagnostic reset command or by a local diagnostic reset command.

Starter Diagnostics

Table 34. Starter diagnostics

Diagnostic Name and Source	Affects Target	Severity	Persistence	Active Modes [Inactive Modes]	Criteria	Reset Level
AFD Drive Fault	Chiller	Immediate	Latch	All	The AFD Drive Fault Relay is open	Local
At Speed Input Opened	Chiller	Immediate	Latch	All Running Modes after At Speed proven	The “At Speed” input was found to be opened with the compressor motor running after successfully obtaining an at speed and bypassed condition. This is active for AFD	Local
At Speed Input Shorted	Chiller	Immediate	Latch	Pre-Start	The “At Speed” input is shorted before the compressor was started. This is active for AFD.	Local
Compressor Did Not Accel: Transition	Chiller	Info	Latch	Start Mode	The compressor did not come up to speed (get to <85%RLA) in the allotted time defined by the Maximum Acceleration Timer and a transition was forced (motor put across the line) at that time. This applies to all starter types. Note: Since RTHD SSS has no forced transition capability, this info warning can be followed with a “Compressor did not accelerate fully” diagnostic above and an aborted start.	Remote
Compressor Did Not Accelerate Fully	Chiller	Immediate	Latch	Start Mode	The starter module did not receive an “Up to Speed” or “End of Ramp” signal from the SSS within 2.5 seconds after commanding a bypass, or after the maximum acceleration time had expired, whichever is longer. This diagnostic only applies to SSS/AFD.	Local
Compressor Did Not Accelerate: Shutdown	Chiller	Immediate	Latch	Start Mode	The compressor did not come up to speed (get to <85%RLA) in the allotted time defined by the Maximum Acceleration Timer and the start was aborted per the starter configuration selected.	Remote

Diagnostics

Table 34. Starter diagnostics (continued)

Diagnostic Name and Source	Affects Target	Severity	Persistence	Active Modes [Inactive Modes]	Criteria	Reset Level
Momentary Power Loss	Chiller	Immediate	Nonlatch	All compressor running and stopping modes [all compressor starting and non-running modes]	<ul style="list-style-type: none"> • Momentary Power Loss option disabled: No effect. • Momentary Power Loss option enabled: A loss of power on three line cycles or more was detected. Diagnostic is reset in 30 seconds. 	Remote
Motor Current Overload	Chiller	Immediate	Latch	Chiller Energized	Compressor current exceeded overload time vs. trip characteristic. For A/C products Must trip = 140% RLA, Must hold=125%, nominal trip 132.5% in 30 seconds	Local
Over Voltage	Chiller	Normal	NonLatch	All	a. Average of all monitored Line voltages above + 10% of nominal. [Must hold = + 10% of nominal. Must trip = + 15% of nominal. Reset differential = min. of 2% and max. of 4%. Time to trip = minimum of 1 min. and maximum of 5 min.) Design: Nom. trip: 60 seconds at greater than 112.5%, + or - 2.5%, Auto Reset at 109% or less.	Remote
Phase Loss	Chiller	Immediate	Latch	Start Sequence and Run modes	a) No current was sensed on one or two of the current transformer inputs while running or starting (See Nonlatching Power Loss Diagnostic for all three phases lost while running). Must hold = 20% RLA. Must trip = 5% RLA. Time to trip shall be longer than guaranteed reset on Starter Module at a minimum, 3 seconds maximum. Actual design trip point is 10%. The actual design trip time is 2.64 seconds. b) If Phase reversal protection is enabled and current is not sensed on one or more current xformer inputs. Logic will detect and trip in a maximum of 0.3 second from compressor start.	Local
Phase Reversal	Chiller	Immediate	Latch	Compressor energized to transition command [All Other Times]	A phase reversal was detected on the incoming current. On a compressor startup the phase reversal logic must detect and trip in a maximum of 0.3 second from compressor start.	Local
Power Loss	Chiller	Immediate	NonLatch	All compressor running modes [all compressor starting and non-running modes]	The compressor had previously established currents while running and then all three phases of current were lost. Design: Less than 10% RLA, trip in 2.64 seconds. This diagnostic will preclude the Phase Loss Diagnostic and the Transition Complete Input Opened Diagnostic from being called out. To prevent this diagnostic from occurring with the intended disconnect of main power, the minimum time to trip must be greater than the guaranteed reset time of the Starter module. Note: This diagnostic prevents nuisance latching diagnostics due to a momentary power loss – It does not protect motor/compressor from uncontrolled power reapplication. See Momentary Power Loss Diagnostic for this protection. This diagnostic will auto reset in 10 seconds from its occurrence, and is not active during the start mode before the transition complete input is proven. This prevents the chiller from cycling due to some internal starter problem, as the starter would latch out on either a “Starter Fault Type 3” or a “Starter Did Not Transition” latching diagnostic. However true power loss occurring during a start would result in a misdiagnosis and the chiller would not automatically recover.	Remote
Severe Current Imbalance	Chiller	Normal	Latch	All Running Modes	A 30% current imbalance has been detected on one phase relative to the average of all 3 phases for 90 continuous seconds.	Local

Table 34. Starter diagnostics (continued)

Diagnostic Name and Source	Affects Target	Severity	Persistence	Active Modes [Inactive Modes]	Criteria	Reset Level
Starter Contactor Interrupt Failure	Chiller	Immediate and Special Action	Latch	Starter Contactor not Energized [Starter Contactor Energized]	Detected compressor currents greater than 10% RLA on any or all phases when the compressor was commanded off. Detection time shall be 5 seconds minimum and 10 seconds maximum. On detection and until the controller is manually reset: generate diagnostic, energize the appropriate alarm relay, continue to energize the Evap and Cond Pump Outputs, continue to command the affected compressor off, fully unload the effected compressor. For as long as current continues, perform liquid level and oil return gas pump control	Local
Starter Did Not Transition	Chiller	Immediate	Latch	On the first check after transition.	The Starter Module did not receive a transition complete signal in the designated time from its command to transition. The must hold time from the Starter Module transition command is 1 second. The Must trip time from the transition command is 6 seconds. Actual design is 2.5 seconds. This diagnostic is active only for Y-Delta, Auto-Transformer, Primary Reactor, and X-Line Starters.	Local
Starter Dry Run Test	Chiller	Immediate	Latch	Starter Dry Run Mode	While in the Starter Dry Run Mode either 50% Line Voltage was sensed at the Potential Transformers or 10% RLA Current was sensed at the Current Transformers.	Local
Starter Fault Type I	Chiller	Immediate	Latch	Starting - Y Delta Starters Only	This is a specific starter test where 1M(1K1) is closed first and a check is made to ensure that there are no currents detected by the CT's. If currents are detected when only 1M is closed first at start, then one of the other contactors is shorted.	Local
Starter Fault Type II	Chiller	Immediate	Latch	Starting All types of starters	a. This is a specific starter test where the Shorting Contactor (1K3) is individually energized and a check is made to ensure that there are no currents detected by the CT's. If current is detected when only S is energized at Start, then 1M is shorted. b. This test in a. above applies to all forms of starters (Note: It is understood that many starters do not connect to the Shorting Contactor.).	Local
Starter Fault Type III	Chiller	Immediate	Latch	Starting [AFD Starter]	As part of the normal start sequence to apply power to the compressor, the Shorting Contactor (1K3) and then the Main Contactor (1K1) were energized. 1.6 seconds later there were no currents detected by the CT's for the last 1.2 seconds on all three phases. The test above applies to all forms of starters.	Local
Transition Complete Input Opened	Chiller	Immediate	Latch	All Running Modes after transition completed	The Transition Complete input is open with the compressor motor running after a successful completion of transition. This is active only for all electromechanical starters	Local
Transition Complete Input Shorted	Chiller	Immediate	Latch	Pre-Start	The Transition Complete input is shorted before the compressor was started. This is active for all electromechanical starters.	Local
Under Voltage	Chiller	Normal	NonLatch	All	a. Average of all monitored Line voltages below - 10% of nominal or the Under/Overvoltage transformer(s) are not connected. [Must hold = - 10% of nominal. Must trip = - 15% of nominal. Reset differential = min. of 2% and max. of 4%. Time to trip = min. of 1 min. and max. of 5 min.) Design: Nom. trip: 60 seconds at less than 87.5%, + or - 2.8% at 200V or + or - 1.8% at 575V, Auto Reset at 90% or greater.	Remote



Diagnostics

Main Processor Diagnostics

Table 35. Main processor diagnostics

Diagnostic Name and Source	Affects Target	Severity	Persistence	Active Modes [Inactive Modes]	Criteria	Reset Level
AFD output power input	Chiller	Info	NonLatch	All	Out-Of-Range Low or Hi or bad LLID, set diagnostic. This Info diagnostic will automatically reset if the input returns to the normal range.	
BAS Communication Lost	Chiller	Special		All	The BAS was setup as "installed" at the MP and the Comm 3 llid lost communications with the BAS for 15 contiguous minutes after it had been established. Refer to Section on Setpoint Arbitration to determine how setpoints and operating modes may be effected by the comm loss. The chiller follows the value of the Tracer Default Run Command which can be previously written by Tracer and stored nonvolatily by the MP (either use local or shutdown).	Remote
BAS Failed to Establish Communication	Chiller	Special		At power-up	The BAS was setup as "installed" and the BAS did not communicate with the MP within 15 minutes after power-up. Refer to Section on Setpoint Arbitration to determine how setpoints and operating modes may be effected. Note: The original requirement for this was 2 minutes, but was implemented at 15 minutes for RTAC.	Remote
Check Clock	Chiller	Info	Latch	All	The real time clock had detected loss of its oscillator at some time in the past. Check / replace battery. This diagnostic can be effectively cleared only by writing a new value to the chiller's time clock using the Tracer TU or TD7 "set chiller time" functions.	Remote
Compressor Discharge Temperature Sensor	Chiller	Immediate	Latch	All	Bad Sensor or LLID	Remote
Condenser Entering Water Temp Sensor	Chiller	Info and Special Action	Latch	All	Bad Sensor or LLID. If chiller running, and condenser water regulating valve option installed, force valve to 100% flow.	Remote
Condenser Leaving Water Temp Sensor	Chiller	Info	Latch	All	Bad Sensor or LLID	Remote
Condenser Rfght Pressure Transducer	Chiller	Normal	Latch	All	Bad Sensor or LLID	Remote
Condenser Water Flow Lost	Chiller	Immediate	NonLatch	Start and All Run Modes	The condenser water flow proof input was open for more than 6 contiguous seconds after flow had been proven. This diagnostic is automatically cleared once the compressor is stopped by a fixed time out of 7 sec. The Cond Pump shall be commanded off but the Evap pump command will not be effected.	Remote
Condenser Water Flow Overdue	Chiller	Normal	NonLatch	Estab Cond Water Flow	Condenser water flow was not proven within 20 minutes of the condenser pump relay being energized. The Cond Pump shall be commanded off. Diagnostic is reset with return of flow (although only possible with external control of pump)	Remote
Emergency Stop	Chiller	Immediate	Latch	All	a. EMERGENCY STOP input is open. An external interlock has tripped. Time to trip from input opening to unit stop shall be 0.1 to 1.0 seconds.	Local
Evap Water Flow (Entering Water Temp)	Chiller	Info	NonLatch	Any Ckt(s) Energized [No Ckt(s) Energized]	The entering evaporator water temp fell below the leaving evaporator water temp. by more than 2°F for 100°F-sec. For falling film evaporators this diagnostic cannot reliably indicate loss of flow, but can warn of improper flow direction through the evaporator, misbound temperature sensors, or other system problems	Remote
Evaporator Entering Water Temp Sensor	Chiller	Info and Special Action	Latch		Bad Sensor or LLID Normal operation unless CHW Reset is enabled. If CHW Reset is enabled and either Return or Constant Return Chilled Water Reset is selected, its effect will be removed but slew rates on the change will be limited per the Chilled Water Reset spec.	Remote

Table 35. Main processor diagnostics (continued)

Diagnostic Name and Source	Affects Target	Severity	Persistence	Active Modes [Inactive Modes]	Criteria	Reset Level
Evaporator Leaving Water Temp Sensor	Chiller	Normal	Latch	All	Bad Sensor or LLID	Remote
Evaporator Liquid Level Sensor	Chiller	Normal	Latch	All	Bad Sensor or LLID	Remote
Evaporator Rfqt Pressure Transducer	Chiller	Normal	Latch	All	Bad Sensor or LLID	Remote
Evaporator Water Flow Lost	Chiller	Immediate	NonLatch	Evap pump commanded "on" except for [All Stop modes]	The Evaporator water flow proof input was open for more than 6-10 contiguous seconds after flow had been proven. The pump command status will not be effected. Even though the pump may be commanded to run in the STOP modes (pump off delay time), this diagnostic shall not be called out in the STOP modes. This diagnostic will auto-clear on proof of flow (6-10 seconds of continuous flow), or if chiller is returned to Stop mode.	Remote
Evaporator Water Flow Overdue	Chiller	Normal	NonLatch	Estab. Evap. Water Flow on going from STOP to AUTO.	Evaporator water flow was not proven within 20 minutes of the Evaporator water pump relay being energized. The Evap pump command status will not be effected. This diagnostic will auto-clear on proof of flow (6-10 seconds of continuous flow), or if chiller is returned to Stop mode.	Remote
External Base Loading Setpoint	Chiller	Info and Special Action	NonLatch	All	a. Not "Enabled": no diagnostics. b. "Enabled ": Out-Of-Range Low or Hi or bad LLID, set diagnostic, default BLS to next level of priority (e.g. Front Panel SetPoint). This Info diagnostic will automatically reset if the input returns to the normal range.	Remote
External Chilled/Hot Water Setpoint	Chiller	Info	NonLatch	All	a. Function Not "Enabled": no diagnostics. b. "Enabled ": Out-Of-Range Low or Hi or bad LLID, set diagnostic, default CWS to next level of priority (e.g. Front Panel SetPoint). This Info diagnostic will automatically reset if the input returns to the normal range.	Remote
External Current Limit Setpoint	Chiller	Info	NonLatch	All	a. Not "Enabled": no diagnostics. b. "Enabled ": Out-Of-Range Low or Hi or bad LLID, set diagnostic, default CLS to next level of priority (e.g. Front Panel SetPoint). This Info diagnostic will automatically reset if the input returns to the normal range.	Remote
High Cprsr Rfqt Discharge Temperature	Chiller	Immediate	Latch	All [compressor not running or during compressor run unload]	The compressor discharge temperature exceeded 190°F. This diagnostic will be suppressed if it occurs during the compressor run-unload period or after the compressor has stopped, but a run unload will be terminated early as a result. Note: As part of the Compressor High Temperature Limit Mode (aka Minimum Capacity Limit), the compressor shall be forced loaded as the filtered discharge temperature nears this trip-point.	Remote
High Differential Refrigerant Pressure	Chiller	Normal	Latch	Chiller Energized	a. The system differential pressure was above 160 Psid-trip immediately (normal shutdown) b. The diff pressure was above 152 Psid - trip in 1 hour	Remote
High Evaporator Liquid Level	Chiller	Normal	Latch	Starter Contactor Energized [all Stop modes]	The liquid level sensor is seen to be at or near its high end of range for 80 contiguous minutes while the compressor is running. (The diagnostic timer will hold, but not clear when the circuit is off). Design: 80% or more of bit count corresponding to +21.2 mm or more liquid level for 80 minutes)	Remote
High Evaporator Refrigerant Pressure	Chiller	Immediate and Special Action	NonLatch	All	The evaporator refrigerant pressure has risen above 190 psig (future use – add "for continuous15 seconds"). The evaporator water pump relay will be de-energized to stop the pump regardless of why the pump is running. The diagnostic will auto reset and the pump will return to normal control when the evaporator pressures falls below 185 psig. This diagnostic must shutdown the chiller if it is running.	Local



Diagnosics

Table 35. Main processor diagnostics (continued)

Diagnostic Name and Source	Affects Target	Severity	Persistence	Active Modes [Inactive Modes]	Criteria	Reset Level
High Evaporator Water Temperature	Chiller	Info and Special Action	NonLatch	Only effective if either 1)Evap Wtr Flow Overdue, 2)Evap Wtr Flow Loss, or 3)Low Evap Rfght Temp,-Unit Off, diagnostic is active.	The leaving water temperature exceeded the high evap water temp limit (TV service menu settable –default 105F) for 15 continuous seconds. The evaporator water pump relay will be de-energized to stop the pump but only if it is running due one of the diagnostics listed on the right. The diagnostic will auto reset and the pump will return to normal control when the temperature falls 5°F below the trip setting. The primary purpose is to stop the evaporator water pump and its associated pump heat from causing excessive waterside temperatures and waterside pressures when the chiller is not running but the evap pump is on due to either Evap Water Flow Overdue, Evaporator Water Flow Loss, or Low Evap Temp – Unit Off Diagnostics. This diagnostic will not auto clear solely due to the clearing of the enabling diagnostic.	Local
High Pressure Cutout	Chiller	Immediate	Latch	All	A high pressure cutout was detected; C.O. on rise @ 180 psig, reset @ 135 psig (+/-5 psi on switching tolerance) Note: Pressure relief valve is 200 Psig +- 2% trip at 315 ± 5 psi. Note: Other diagnostics that may occur as an expected consequence of the HPC trip will be suppressed from annunciation. These include Phase Loss, Power Loss, and Transition Complete Input Open.	Local
High Refrigerant Pressure Ratio	Chiller	Immediate	Latch	Service Pumpdown Only	The system pressure ratio exceeded 5.61 for 1 contiguous minute. This pressure ratio is a fundamental limitation of the compressor. The pressure ratio is defined as Pcond (abs)/Pevap(abs).	Remote
LCI-C Software Mismatch: Use BAS Tool	Chiller	info	NonLatch	All	The neuron software in the LCI-C module does not match the chiller type. Download the proper software into the LCI-C neuron. To do this, use the Rover service tool, or a LonTalk® tool capable of downloading software to a Neuron 3150®.	Remote
Loss of Oil at Compressor (Running)	Chiller	Immediate	Latch	Starter Contactor Energized	In running modes, Oil Loss Level Sensor detects lack of oil in the oil tank feeding the compressor (distinguishing a liquid flow from a vapor flow)	Local
Loss of Oil at Compressor (Stopped)	Chiller	Immediate and Special Action	Latch	Compressor Pre-start [all other modes]	Oil Loss Level Sensor detects a lack of oil in the oil tank feeding the compressor for 90 seconds after EXV preposition is completed. Note: Compressor start is delayed while waiting for oil to be detected.	Local
Low Differential Refrigerant Pressure	Chiller	Immediate	Latch	Chiller Energized	The system differential pressure was either below 15 Psid for more than 164 Psid-sec, or below 23.0 Psid for 3000 Psid-sec. The latter integral's value is not cleared for any reason including diagnostic trip, manual reset, or power up reset (ie. Integral is saved nonvolatily on power down). The integral will decay while circuit is running at a max rate of –10 PSID, and while stopped at a rate of –0.4 PSID. This same integral is associated with the operating mode “Compressor Cool Down”. Also see diagnostic below	Remote
Low Discharge Superheat	Chiller	Normal	Latch	Any Running Mode	While Running Normally, the Discharge Superheat was less than 12 degrees F +- 1F for more than 6500 degree F seconds. At startup the UCM shall ignore the Discharge Superheat for 5 minutes.	Remote
Low Evaporator Liquid Level	Chiller	Info	NonLatch	Starter Contactor Energized [all Stop modes]	The liquid level sensor is seen to be at or near its low end of range for 80 contiguous minutes while the compressor is running. Design: 20% or less of bit count corresponding to –21.2 mm or less liquid level for 80 minutes)	Remote
Low Evaporator Refrigerant Pressure	Chiller	Immediate	Latch	Chiller Prestart and Chiller Energized	The Evaporator Refrigerant Pressure dropped below 10 psia just prior to compressor start. The pressure fell below 10 psia while running but before the 3 minute ignore time had expired or fell below 16 Psia after the 3 minute ignore time had expired.	Local

Table 35. Main processor diagnostics (continued)

Diagnostic Name and Source	Affects Target	Severity	Persistence	Active Modes [Inactive Modes]	Criteria	Reset Level
Low Evaporator Refrigerant Temperature	Chiller	Immediate	Latch	All Ckt Running Modes	a. The inferred Saturated Evap Refrigerant Temperature (calculated from suction pressure transducer(s)) dropped below the Low Refrigerant Temperature Cutout Setpoint for 450°F-sec (10°F-sec max rate) while the circuit was running after the ignore period had expired. The integral is held at zero for the 1 minute ignore time following the circuit startup and the integral will be limited to never trip in less than 45 seconds, i.e. the error term shall be clamped to 10°F. The minimum LRTC setpoint is -5°F (18.7 Psia) the point at which oil separates from the refrigerant. b. During the timeout of the trip integral, the unload solenoid(s) of the running compressors on the circuit, shall be energized continuously and the load solenoid shall be off. Normal load/unload operation will be resumed if the trip integral is reset by return to temps above the cutout setpoint.	Remote
Low Evaporator Temp: Unit Off	Chiller	Info and Special Action	NonLatch	Unit in Stop Mode, or in Auto Mode and No Ckt's Energizd [Any Ckt Energizd]	The evap sat temp fell below the water temp cutout setting while the respective evap liquid level was greater than -21.2mm for 30 (or 150 beginning with rev 08) degree F seconds while Chiller is in the Stop mode, or in Auto mode with no compressors running. Energize Evap Water pump Relay until diagnostic auto resets, then return to normal evap pump control. Automatic reset occurs when either the evap temp rises 2°F (1.1°C) above the cutout setting or the liquid level falls below -21.2mm for 30 minutes.	Remote
Low Evaporator Water Temp (Unit Off)	Chiller	Info and Special Action	NonLatch	Unit in Stop Mode, or in Auto Mode and No Ckt(s) Energized [Any Ckt Energized]	The leaving Evaporator water temp. fell below the leaving water temp cutout setting for 30°F-seconds while the Chiller is in the Stop mode, or in Auto mode with no compressors running. Energize Evap Water pump Relay until diagnostic auto resets, then return to normal evap pump control. Automatic reset occurs when the temp rises 2°F (1.1°C) above the cutout setting for 30 minutes.	Remote
Low Evaporator Water Temp (Unit On)	Chiller	Immediate and Special Action	NonLatch	Any Ckt[s] Energized [No Ckt(s) Energizd]	The Evaporator water temp. fell below the cutout setpoint for 30 degree F Seconds while the compressor was running. Automatic reset occurs when the temperature rises 2°F (1.1°C) above the cutout setting for 2 minutes. This diagnostic shall not de-energize the Evaporator Water Pump Output.	Remote
Low Oil Flow	Chiller	Immediate	Latch	Chiller Energized and Delta P above 15 Psid	The oil pressure was out of the acceptable pressure range for 15 seconds, while the Delta Pressure was greater than 15 Psid.: Acceptable range is 0.50 or 0.60 > (PC-Po) / (PC-PE) for the first 2.5 minutes of operation, and 0.40 or 0.50 > (PC-Po) / (PC-PE) thereafter. The higher ratios used if the system DP is less than 23 psid	Local
MP: Could not Store Starts and Hours	None	Info	Latch	All	MP has determined there was an error with the previous power down store. Starts and Hours may have been lost for the last 24 hours.	Remote
MP: Invalid Configuration	None	Immediate	Latch	All	MP has an invalid configuration based on the current software installed	Remote
MP: Non-Volatile Block Test Error	None	Info	Latch	All	MP has determined there was an error with a block in the Non-Volatile memory. Check settings.	Remote
MP: Non-Volatile Memory Reformat	None	Info	Latch	All	MP has determined there was an error in a sector of the Non-Volatile memory and it was reformatted. Check settings.	Remote
MP: Reset Has Occurred	Chiller	Info	NonLatch	All	The main processor has successfully come out of a reset and built its application. A reset may have been due to a power up, installing new software or configuration. This diagnostic is immediately and automatically cleared and thus can only be seen in the Historic Diagnostic List in Tracer TU.	Remote
No Differential Refrigerant Pressure	Chiller	Immediate	Latch	Chiller Energized	The system differential pressure was below 7.7 Psid. The occurrence of this diagnostic will saturate the above "Low Diff Rfght Press" Integral and invoke the same "Compressor Cool Down" op mode.	Remote



Diagnostics

Table 35. Main processor diagnostics (continued)

Diagnostic Name and Source	Affects Target	Severity	Persistence	Active Modes [Inactive Modes]	Criteria	Reset Level
Oil Flow Protection Fault	Chiller	Immediate	Latch	Starter Contactor Energized [all Stop modes]	The Oil Pressure Transducer for this Chiller is reading a pressure either above its Condenser Pressure by 15 Psia or more, or below its Evaporator Pressure 10 Psia or more for 30 seconds continuously.	Local
Oil Pressure Transducer	Chiller	Normal	Latch	All	Bad Sensor or LLID	Remote
Outdoor Air Temperature Sensor	Chiller	Info and Special Action	Latch	All	Bad Sensor or LLID. This diagnostic will only occur if OA sensor is configured. OA Chilled water reset will be suspended if selected and Tracer OA unavailable.	Remote
Refrigerant Monitor Input	Chiller	Info	NonLatch	All –if installed	Open or Shorted input and the Rfgr Monitor is setup as installed	Remote
Restart Inhibit	Chiller	Info	NonLatch	All	The Restart Inhibit was invoked on a compressor. This indicates excessive chiller cycling which should be corrected.	Remote
Software Error Number: 1001 Call Trane Service	All functions	Immediate	Latch – power down reset is reqd	All	A high level software watchdog has detected a condition in which there was a continuous 5 minute period of compressor operation, with neither chilled water flow nor a "contactor interrupt failure" diagnostic active. The occurrence of this software error message suggests an internal software state chart misalignment has occurred. The events that led up to this failure, if known, should be recorded and transmitted to Trane Controls Engineering – (SW rev 6 and higher)	Local
Starter Failed to Arm/Start	Chiller	Info	Latch	All	Starter failed to arm or start within the allotted time (2 minutes).	Remote
Starter Module Memory Error Type 1	Chiller	Info	Latch	All	Checksum on RAM copy of the Starter LLID configuration failed. Configuration recalled from EEPROM.	Local
Starter Module Memory Error Type 2 -	Chiller	Immediate	Latch	All	Checksum on EEPROM copy of the Starter LLID configuration failed. Factor default values used.	Local
Unexpected Starter Shutdown	Chiller	Normal	Nonlatch	All Cprsr Running modes, Starting, Running and Preparing to Shutdown	The Starter module status reported back that it is stopped when it should be running and no Starter diagnostic exists. This diagnostic will be logged in the active buffer and then cleared.	NA

Communication Diagnostics

Notes:

- The following communication loss diagnostics will not occur unless that input or output is required to be present by the particular configuration and installed options for the chiller.
- Communication diagnostics (with the exception of "Excessive Loss of Comm" are named by the Functional Name of the input or output that is no longer being heard from by the Main Processor. Many

LLIDs, such as the Quad Relay LLID, have more than one functional output associated with it. A comm loss with such a multiple function board, will generate multiple diagnostics. Refer to the Chiller's wiring diagrams to relate the occurrence of multiple communication diagnostics back to the physical LLID boards that they have been assigned to (bound).

Table 36. Communication diagnostics

Diagnostic Name	Affects	Severity	Persistence	Active Modes [Inactive Modes]	Criteria	Reset Level
Excessive Loss of Comm	Chiller	Immediate	Latch	All	Loss of comm with 20% or more of the llids configured for the system has been detected. This diagnostic will suppress the callout of all subsequent comm loss diagnostics. Check power supply(s) and power disconnects – troubleshoot LLIDS buss using Tracer TU	Remote
Comm Loss: Slide Valve Unload	Chiller	Normal	Latch	All	Continual loss of communication between the MP and the Functional ID has occurred for a 30 second period.	Remote
Comm Loss: Slide Valve Load	Chiller	Normal	Latch	All	Continual loss of communication between the MP and the Functional ID has occurred for a 30 second period.	Remote
Comm Loss: External Auto/Stop	Chiller	Normal	Latch	All	Continual loss of communication between the MP and the Functional ID has occurred for a 30 second period.	Remote
Comm Loss: Emergency Stop	Chiller	Normal	Latch	All	Continual loss of communication between the MP and the Functional ID has occurred for a 30 second period.	Remote
Comm Loss: External Ice Building Command		Normal	Latch	All	Continual loss of communication between the MP and the Functional ID has occurred for a 30 second period. Chiller shall revert to normal (non-ice building) mode regardless of last state.	Remote
Comm Loss: Ice Building Status Relay		Normal	Latch	All	Continual loss of communication between the MP and the Functional ID has occurred for a 30 second period. Chiller shall revert to normal (non-ice building) mode regardless of last state.	Remote
Comm Loss: Outdoor Air Temperature	Chiller	Info and Special Action	Latch	All	Continual loss of communication between the MP and the Functional ID has occurred for a 30 second period. Note that if this diagnostic occurs, Chiller shall remove any OA Chilled Water Reset, if it was in effect and if Tracer OA was unavailable. Apply slew rates per Chilled Water Reset spec	Remote
Comm Loss: Evap Leaving Water Temp		Normal	Latch	All	Continual loss of communication between the MP and the Functional ID has occurred for a 30 second period.	Remote
Comm Loss: Evap Entering Water Temp		Info and Special Action	Latch	All	Continual loss of communication between the MP and the Functional ID has occurred for a 30 second period. Chiller shall remove any Return or Constant Return Chilled Water Reset, if it was in effect. Apply slew rates per Chilled Water Reset spec.	Remote
Comm Loss: Condenser Leaving Water Temp		Info	Latch	All	Continual loss of communication between the MP and the Functional ID has occurred for a 30 second period.	Remote
Comm Loss: Condenser Entering Water Temp		Info and Special Action	Latch	All	Continual loss of communication between the MP and the Functional ID has occurred for a 30 second period. If chiller running, and condenser water regulating valve option installed, force valve to 100% flow.	Remote
Comm Loss: Cprsr Discharge Rfgt Temp		Immediate	Latch	All	Continual loss of communication between the MP and the Functional ID has occurred for a 30 second period.	Remote
Comm Loss: Ext Chilled/Hot Water Setpoint		Info and Special Action	Latch	All	Continual loss of communication between the MP and the Functional ID has occurred for a 30 second period. Chiller shall discontinue use of the External Chilled Water Setpoint source and revert to the next higher priority for setpoint arbitration	Remote



Diagnostics

Table 36. Communication diagnostics (continued)

Diagnostic Name	Affects	Severity	Persistence	Active Modes [Inactive Modes]	Criteria	Reset Level
Comm Loss: Ext Current Limit Setpoint		Info and Special Action	Latch	All	Continual loss of communication between the MP and the Functional ID has occurred for a 30 second period. Chiller shall discontinue use of the External Current limit setpoint and revert to the next higher priority for Current Limit setpoint arbitration	Remote
Comm Loss: High Pressure Cutout Switch	Chiller	Normal	Latch	All	Continual loss of communication between the MP and the Functional ID has occurred for a 30 second period.	Remote
Comm Loss: Evaporator Water Flow Switch		Immediate	Latch	All	Continual loss of communication between the MP and the Functional ID has occurred for a 30 second period.	Remote
Comm Loss: Condenser Water Flow Switch	Chiller	Immediate	Latch	All	Continual loss of communication between the MP and the Functional ID has occurred for a 30 second period.	Remote
Comm Loss: Evaporator Rfqt Pressure	Chiller	Normal	Latch	All	Continual loss of communication between the MP and the Functional ID has occurred for a 30 second period.	Remote
Comm Loss: Condenser Rfqt Pressure	Chiller	Normal	Latch	All	Continual loss of communication between the MP and the Functional ID has occurred for a 30 second period.	Remote
Comm Loss: Oil Pressure	Chiller	Normal	Latch	All	Continual loss of communication between the MP and the Functional ID has occurred for a 30 second period.	Remote
Comm Loss: Oil Return Gas Pump Fill	Chiller	Normal	Latch	All	Continual loss of communication between the MP and the Functional ID has occurred for a 30 second period.	Remote
Comm Loss: Oil Return Gas Pump Drain	Chiller	Normal	Latch	All	Continual loss of communication between the MP and the Functional ID has occurred for a 30 second period.	Remote
Comm Loss: Oil Loss Level sensor Input	Chiller	Normal	Latch	All	Continual loss of communication between the MP and the Functional ID has occurred for a 30 second period.	Remote
Comm Loss: Master Oil Line SV		Normal	Latch	All	Continual loss of communication between the MP and the Functional ID has occurred for a 30 second period.	Remote
Comm Loss: Evaporator Water Pump Relay		Info	Latch	All	Continual loss of communication between the MP and the Functional ID has occurred for a 30 second period.	Remote
Comm Loss: Condenser Water Pump Relay		Info	Latch	All	Continual loss of communication between the MP and the Functional ID has occurred for a 30 second period.	Remote
Comm Loss: SSS/AFD Fault		Info	Latch	All	Continual loss of communication between the MP and the Functional ID has occurred for a 30 second period.	Remote
Comm Loss: Refrigerant Monitor Input	Chiller	Info	Latch	All	Continual loss of communication between the MP and the Functional ID has occurred for a 30 second period.	Remote
Comm Loss: Ext Base Loading Setpoint		Info and Special Action	Latch	All	Continual loss of communication between the MP and the Functional ID has occurred for a 30 second period. The external base load setpoint input is removed from the arbitration to establish the Base Loading Setpoint.	Remote
Comm Loss: Ext Base Loading Command		Info and Special Action	Latch	All	Continual loss of communication between the MP and the Functional ID has occurred for a 30 second period. The external base load input is removed from the arbitration to enable Base Loading.	Remote
Comm Loss: Evaporator Rfqt Liquid Level	Chiller	Normal	Latch	All	Continual loss of communication between the MP and the Functional ID has occurred for a 30 second period.	Remote
Comm Loss: Starter	Chiller	Immediate	Latch	All	Continual loss of communication between the MP and the Functional ID has occurred for a 30 second period.	Local
Comm Loss: Electronic Expansion Valve 1		Normal	Latch	All	Continual loss of communication between the MP and the Functional ID has occurred for a 30 second period.	Remote
Comm Loss: Electronic Expansion Valve 2		Normal	Latch	All	Continual loss of communication between the MP and the Functional ID has occurred for a 30 second period.	Remote
Starter Comm Loss: Main Processor	Chiller	Immediate	Latch	All	Starter has had a loss of communication with the MP for a 15 second period.	Local
Comm Loss: Local BAS Interface	Chiller	Info and Special Action	Latch	All	Continual loss of communication between the MP and the Functional ID has occurred for a 30 second period. Use the last values sent from BAS	Remote
Comm Loss: Op Status Programmable Relays	Chiller	Info	Latch	All	Continual loss of communication between the MP and the Functional ID has occurred for a 30 second period.	Remote
Comm Loss: Compressor % RLA Output	Chiller	Info	Latch	All	Continual loss of communication between the MP and the Functional ID has occurred for a 30 second period.	Remote

Table 36. Communication diagnostics (continued)

Diagnostic Name	Affects	Severity	Persistence	Active Modes [Inactive Modes]	Criteria	Reset Level
Comm Loss: Cond Rfgt Pressure Output		Normal		All	Continual loss of communication between the MP and the Functional ID has occurred for a 30 second period.	Remote
Comm Loss: Cond Head Press Cntrl Output	Chiller	Immediate	Latch	All	Continual loss of communication between the MP and the Functional ID has occurred for a 30 second period.	Remote
Comm Loss: AFD speed signal output	Chiller	Immediate	Latch	All	Continual loss of communication between the MP and the Functional ID has occurred for a 30 second period.	Remote
Comm Loss: AFD output power input	Chiller	Immediate	Latch	All	Continual loss of communication between the MP and the Functional ID has occurred for a 30 second period.	Remote
Comm Loss: External Hot Water Command	Chiller	Info	Warning Reset	All	Continual loss of communication between the MP and the Functional ID has occurred for a 30 second period.	Remote

Operator Display Diagnostics and Messages

Table 37. Operator display diagnostics and messages

Operator Display Message	Description //Troubleshooting
Communication Lost with UC800	<ul style="list-style-type: none"> Ethernet cable not connected between display and UC800. UC800 not powered. UC800 has an invalid configuration – Download a valid configuration UC800 is in Binding View. When exit Binding View, select 'Restart' on this message.
Display Failed to Establish Communication	<ul style="list-style-type: none"> Ethernet cable not connected between display and UC800. UC800 not powered. UC800 just has the backup application running as received from the vendor. Download CTV application software. UC800 has an invalid configuration – Download a valid configuration
Display is about to Restart	<ul style="list-style-type: none"> The display is low on memory, and needs to re-start. Select Yes to restart. Selecting Yes will not affect the UC800 operation. Only the Operator Display is reset.
File Not Found	Update UC800 software with Tracer TU.
Screen partially populated. Auto and Stop button graphics display, no text.	Valid configuration is not present. Download a configuration.
Screen Unresponsive	TU is downloading software. Wait till download is complete.
The Page Cannot be found	<ul style="list-style-type: none"> Most likely this UC800 has only the backup application. Download the latest UC 800 software build. This could also mean that the UC800 does not have a valid configuration. Download a configuration to it. Cycle power to the OD and UC800. UC could be in binding view. If so, get it out of binding view by navigating to another screen in TU.
UC800 Configuration is Invalid	Update the UC800 configuration with TU.



Wiring

Table 38 and Table 39 provide lists of field wiring diagrams, electrical schematics and connection diagrams for the Optimus™ units. The complete unit wiring package is documented in RTHD-SVE01*-EN. A laminated wiring diagram kit is also shipped with each RTHD unit.

To determine the specific electrical characteristics of a particular chiller, see the nameplates mounted on the units.

Table 38. Wiring drawings — wye-delta units

Drawing	Description
2309-7552	Schematic
2309-7553	Schematic
2309-7554	Schematic
2309-7555	Schematic
2309-7564	Component Location
2309-4870	Field Wiring
2309-4869	Field Layout

Table 39. Wiring drawings — AFD units

Drawing	Description
2311-1975	Schematic
2311-1977	Component Location
2311-1976	Field Wiring
2311-0023	Field Layout



Log and Check Sheets

The operator log and check sheet are included for use as appropriate, for installation completion verification before Trane start-up is scheduled, and for reference during the Trane start-up.

Where the log or check sheet also exists outside of this publication as standalone literature, the literature order number is also listed.

- Optimus™ RTHD Installation Completion Check Sheet and Request for Trane Service (RLC-ADF005*-EN)
- Chiller Settings
- Operator Log



Log and Check Sheets

Page left intentionally blank



Optimus™ Model RTHD Chiller Installation Completion Check Sheet and Request for Trane Service

Important: A copy of this completed form must be submitted to the Trane service agency that will be responsible for the start-up of the chiller. Start-up will NOT proceed unless applicable items listed in this form have been satisfactorily completed. **See unit IOM RTHD-SVX01*-EN for detailed installation instructions.**

To:	Trane Service Office:
S.O. Number:	Serial Numbers:
Job/Project Name:	
Address:	

The following items are being installed and will be completed by:

Important: Start-up must be performed by Trane or an agent of Trane specifically authorized to perform start-up of Trane® products. Contractor shall provide Trane (or an agent of Trane specifically authorized to perform start-up) with notice of the scheduled start-up at least two weeks prior to the scheduled start-up.

Important: It is required that heaters are energized for a minimum of 24 hours prior to start up. Therefore, chiller should have power for this amount of time before Trane Service arrives to do start-up.

Check boxes if the task is complete or if the answer is "yes."

1. Screw Chiller

- Installation meets foundation requirements.
- In place and piped.
- Isolation pads installed.

2. Piping

Note: See bulletin RLC-PRB015*-EN for piping installation considerations affecting sound.

Chilled water piping connected to:

- Evaporator
- Air handling units
- Pumps
- Flow switch or flow proving device installed (if not factory provided)
- Strainer installed and cleaned

Condenser and heat recovery condenser (as applicable) piping connected to:

- Condenser
- Pumps
- Flow switch or flow proving device installed (if not factory provided)
- Cooling tower
- Heating loop (as applicable)
- Make-up water connected to cooling tower
- Water supply connected to filling system
- Does unit have freeze inhibitor? If unit has freeze inhibitor:
 - Verify type and concentration correct per unit submittal
 - Calculate and record freeze point of the solution: _____
- Systems filled
- Pumps run, air bled from system
- Strainer installed in entering water piping (evaporator and condenser) and cleaned
- Relief valve ventilation piping installed (if applicable)

3. Flow balancing valves installed

- Leaving chilled water
- Leaving condenser water
- Proper porting to measure flow and balance
- Optional heat recovery or auxiliary condenser water (if applicable)

4. Gauges, thermometers, and air vents

- Installed on both sides of evaporator
- Installed on both sides of condenser and heat recovery condenser (as applicable)

5. Wiring

- Wire size per submittal and NEC 310-16.
- Full power available
- External interlocks (flow switch, pumps auxiliary, etc.)
- Chilled water pump (connected and tested)
- Condenser water pump (connected and tested)
- Cooling tower fan rotation checked
- Heat recovery condenser water pump (as applicable)
- 115 Vac power available for service tools as required
- All controls installed and connected

6. Testing

- Dry nitrogen available for pressure testing
- Trace gas amounts of R-134a available for leak testing, if necessary

7. Refrigerant on job site**8. Systems can be operated under all actual load conditions****9. Heaters**

- Energize oil sump and compressor heaters and verify they are operational using a temperature probe.
- If unit was factory charged (model number digit 35 = A), **energize heaters for 24 hours prior to start up.**
Important: It is required that heaters are energized for a minimum of 24 hours prior to start up. Therefore, chiller should have power for this amount of time before Trane Service arrives to do start-up.
- If unit has nitrogen charge (model number digit 45 = 1), contact Trane Service for unit charging prior to start-up.

10. Equipment room

- Does the equipment room have a refrigerant monitor/sensor capable of monitoring and alarming within the allowable exposure level of the refrigerant?
- Does the installation have properly placed and operating audible and visual refrigerant alarms?
- Does the equipment room have proper mechanical ventilation?
- If it is required by local code, is a self-contained breathing apparatus available?

11. Owner awareness

- Does the owner have a copy of the MSDS for refrigerant?

Note: Additional time required to properly complete the start-up and commissioning, due to any incompleteness of the installation, will be invoiced at prevailing rates.

This is to certify that the Trane® equipment has been properly and completely installed, and that the applicable items listed above have been satisfactorily completed.

Important: It is required that the chiller heaters are energized for a minimum of 24 hours prior to start up. Therefore, the chiller should have power for this amount of time before Trane Service arrives to do start-up of the equipment.

Checklist completed by: _____

Signed: _____ Date: _____

In accordance with your quotation and our purchase order number _____, we will therefore require the presence of Trane service on this site, for the purpose of start-up and commissioning, by _____ (date).

Note: Minimum two-week advance notification is required to allow scheduling of the chiller start-up.

Additional comments/instructions: _____

A copy of this completed form must be submitted to the Trane Service Office that will be responsible for start-up of chiller.



Ingersoll Rand (NYSE:IR) advances the quality of life by creating comfortable, sustainable and efficient environments. Our people and our family of brands—including Club Car®, Ingersoll Rand®, Thermo King® and Trane®—work together to enhance the quality and comfort of air in homes and buildings; transport and protect food and perishables; and increase industrial productivity and efficiency. We are a global business committed to a world of sustainable progress and enduring results. For more information, visit www.ingersollrand.com.

Ingersoll Rand has a policy of continuous product and product data improvement and reserves the right to change design and specifications without notice.

Chiller Settings

Settings	
Settings Tab	
Chiller	
Front Panel Chilled Water Setpt (F)	
Front Panel Current Limit Setpt (RLA)	
Differential to Start (F)	
Differential to Stop (F)	
Setpoint Source	
Feature Settings	
Chilled Water Reset	
Return Reset Ratio	
Return Start Reset	
Return Maximum Reset	
Outdoor Reset Ratio	
Outdoor Start Reset	
Outdoor Maximum Reset	
Mode Overrides	
Evap Water Pump	
Cond Water Pump	
Expansion Valve Control	
Slide Valve Control	
Service Pumpdown	
Display Settings	
Date Format	
Date	
Time Format	
Time of Day	
Keypad/Display Lockout	
Display Units	
Pressure Units	
Language Selection	

Operator Log

Chiller Log			
Main Tab	Run Time		
	15 min	30 min	1 hr
Chiller Mode			
Evap Ent/Lvg Water Temp			
Cond Ent/Lvg Water Temp			
Active Chilled Water Setpoint (F)			
Average Line Current (%RLA)			
Active Current Limit Setpoint (%RLA)			
Software Type			
Software Version			
Reports Tab			
Evaporator			
Evap Entering Water Temperature (F)			
Evap Leaving Water Temperature (F)			
Evap Sat Rfgt Temp (F)			
Evap Rfgt Pressure (psia)			
Evap Approach Temp (F)			
Evap Water Flow Switch Status			
Expansion Valve Position (%)			
Expansion Valve Position Steps			
Evap Rfgt Liquid Level (in)			
Condenser			
Cond Entering Water Temperature (F)			
Cond Leaving Water Temperature (F)			
Cond Sat Rfgt Temp (F)			
Cond Rfgt Pressure (psia)			
Cond Approach Temp (F)			
Cond Water Flow Switch Status			
Cond Head Pressure Ctrl Command (%)			
Compressor			
Compressor Starts			
Compressor Run Time			
System Rfgt Diff Pressure (psid)			
Oil Pressure (psia)			
Compressor rfgt Discharge Temp (F)			
Discharge Superheat (F)			
% RLA L1 L2 L3 (%)			
Amps L1 L2 L3 (Amps)			
Volts AB BC CA			



Ingersoll Rand (NYSE:IR) advances the quality of life by creating comfortable, sustainable and efficient environments. Our people and our family of brands—including Club Car®, Ingersoll Rand®, Thermo King® and Trane®—work together to enhance the quality and comfort of air in homes and buildings; transport and protect food and perishables; and increase industrial productivity and efficiency. We are a global business committed to a world of sustainable progress and enduring results. For more information, visit www.ingersollrand.com.

Ingersoll Rand has a policy of continuous product and product data improvement and reserves the right to change design and specifications without notice.