



# Installation, Operation, and Maintenance

**Ascend™ Air-Cooled Chiller — Model ACR**  
With AdaptiSpeed™ Technology  
Quiet operation enabled by InvisiSound™ Technology  
150 to 300 Nominal Tons



## ⚠ SAFETY WARNING

Only qualified personnel should install and service the equipment. The installation, starting up, and servicing of heating, ventilating, and air-conditioning equipment can be hazardous and requires specific knowledge and training. Improperly installed, adjusted or altered equipment by an unqualified person could result in death or serious injury. When working on the equipment, observe all precautions in the literature and on the tags, stickers, and labels that are attached to the equipment.



# Introduction

Read this manual thoroughly before operating or servicing this unit.

## Warnings, Cautions, and Notices

Safety advisories appear throughout this manual as required. Your personal safety and the proper operation of this machine depend upon the strict observance of these precautions.

The three types of advisories are defined as follows:



Indicates a potentially hazardous situation which, if not avoided, could result in death or serious injury.



Indicates a potentially hazardous situation which, if not avoided, could result in minor or moderate injury. It could also be used to alert against unsafe practices.



Indicates a situation that could result in equipment or property-damage only accidents.

## Important Environmental Concerns

Scientific research has shown that certain man-made chemicals can affect the earth's naturally occurring stratospheric ozone layer when released to the atmosphere. In particular, several of the identified chemicals that may affect the ozone layer are refrigerants that contain Chlorine, Fluorine and Carbon (CFCs) and those containing Hydrogen, Chlorine, Fluorine and Carbon (HCFCs). Not all refrigerants containing these compounds have the same potential impact to the environment. Trane advocates the responsible handling of all refrigerants-including industry replacements for CFCs and HCFCs such as saturated or unsaturated HFCs and HCFCs.

## Important Responsible Refrigerant Practices

Trane believes that responsible refrigerant practices are important to the environment, our customers, and the air conditioning industry. All technicians who handle refrigerants must be certified according to local rules. For the USA, the Federal Clean Air Act (Section 608) sets forth the requirements for handling, reclaiming, recovering and recycling of certain refrigerants and the equipment that is used in these service procedures. In addition, some states or municipalities may have additional requirements that must also be adhered to for responsible management of refrigerants. Know the applicable laws and follow them.

### ⚠ WARNING

#### Proper Field Wiring and Grounding Required!

Failure to follow code could result in death or serious injury.

All field wiring **MUST** be performed by qualified personnel. Improperly installed and grounded field wiring poses **FIRE** and **ELECTROCUTION** hazards. To avoid these hazards, you **MUST** follow requirements for field wiring installation and grounding as described in **NEC** and your local/state/national electrical codes.

### ⚠ WARNING

#### Personal Protective Equipment (PPE) Required!

Failure to wear proper PPE for the job being undertaken could result in death or serious injury. Technicians, in order to protect themselves from potential electrical, mechanical, and chemical hazards, **MUST** follow precautions in this manual and on the tags, stickers, and labels, as well as the instructions below:

- Before installing/servicing this unit, technicians **MUST** put on all PPE required for the work being undertaken (Examples; cut resistant gloves/sleeves, butyl gloves, safety glasses, hard hat/bump cap, fall protection, electrical PPE and arc flash clothing). **ALWAYS** refer to appropriate Material Safety Data Sheets (MSDS)/Safety Data Sheets (SDS) and OSHA guidelines for proper PPE.
- When working with or around hazardous chemicals, **ALWAYS** refer to the appropriate MSDS/SDS and OSHA/GHS (Global Harmonized System of Classification and Labelling of Chemicals) guidelines for information on allowable personal exposure levels, proper respiratory protection and handling instructions.
- If there is a risk of energized electrical contact, arc, or flash, technicians **MUST** put on all PPE in accordance with OSHA, NFPA 70E, or other country-specific requirements for arc flash protection, **PRIOR** to servicing the unit. **NEVER PERFORM ANY SWITCHING, DISCONNECTING, OR VOLTAGE TESTING WITHOUT PROPER ELECTRICAL PPE AND ARC FLASH CLOTHING. ENSURE ELECTRICAL METERS AND EQUIPMENT ARE PROPERLY RATED FOR INTENDED VOLTAGE.**

**⚠ WARNING****Follow EHS Policies!**

Failure to follow instructions below could result in death or serious injury.

- All Ingersoll Rand personnel must follow Ingersoll Rand Environmental, Health and Safety (EHS) policies when performing work such as hot work, electrical, fall protection, lockout/tagout, refrigerant handling, etc. All policies can be found on the [BOS site](#). Where local regulations are more stringent than these policies, those regulations supersede these policies.
- Non-Ingersoll Rand personnel should always follow local regulations.

**⚠ WARNING****Refrigerant under High Pressure!**

Failure to follow instructions below could result in an explosion which could result in death or serious injury or equipment damage.

System contains refrigerant under high pressure. Recover refrigerant to relieve pressure before opening the system. See unit nameplate for refrigerant type. Do not use non-approved refrigerants, refrigerant substitutes, or refrigerant additives.

**Factory Warranty Information**

Compliance with the following is required to preserve the factory warranty:

***All Unit Installations***

Startup **MUST** be performed by Trane, or an authorized agent of Trane, to **VALIDATE** this WARRANTY.

Contractor must provide a two-week startup notification to Trane (or an agent)

**Copyright**

This document and the information in it are the property of Trane, and may not be used or reproduced in whole or in part without written permission. Trane reserves the right to revise this publication at any time, and to make changes to its content without obligation to notify any person of such revision or change.

**Trademarks**

All trademarks referenced in this document are the trademarks of their respective owners.

**Factory Training**

Factory training is available through Trane University™ to help you learn more about the operation and maintenance of your equipment. To learn about available training opportunities contact Trane University™.

Online: [www.trane.com/traneuniversity](http://www.trane.com/traneuniversity)

Phone: 855-803-3563

Email: [traneuniversity@trane.com](mailto:traneuniversity@trane.com)

**Revision History**

- Updated point weight information.
- Added Adaptive Frequency™ drive power jumper configuration section to Installation Electrical chapter.
- Added Integrated Rapid Restart™ section to Controls chapter.



# Table of Contents

Model Number Information .....	7	Mounting Locations, Weights, Isolators.....	27
Nameplates .....	7	Compressor Mounting Bolt Removal .....	30
Unit Nameplate .....	7	Drainage.....	30
Model Number Coding System.....	7	Refrigerant Pressure Relief Valves .....	31
Compressor Nameplate .....	7	Evaporator Piping .....	31
Model Number Descriptions.....	8	Evaporator Piping Components .....	32
Unit Model Number.....	8	Evaporator Waterside Pressure Drop Curves.....	34
Compressor Information .....	10	Freeze Protection .....	35
Model Number .....	10	Low Evaporator Refrigerant Cutout, Glycol Requirements .....	37
Serial Number .....	10	Installation Electrical .....	38
General Information .....	11	General Recommendations.....	38
Unit Description .....	11	Adaptive Frequency™ Drive Capacitor Discharge.....	39
Unit Length .....	11	Adaptive Frequency™ Drive Power Jumper Configuration .....	39
Accessory/Option Information .....	11	Units with Nitrogen Charge Option .....	40
General Data .....	12	Installer-Supplied Components .....	40
Drive Cooling Fluid .....	14	Power Supply Wiring.....	40
Pre-Installation .....	15	Control Power Supply .....	41
Unit Inspection .....	15	Service Power Connection .....	41
Exterior Inspection .....	15	Heater Power Supply .....	42
Inspection for Concealed Damage .....	15	Chilled Water Pump Control .....	42
Repair.....	15	Programmable Relays .....	43
Storage Requirements .....	15	Relay Assignments Using Tracer TU .....	43
Installation Requirements .....	16	Low Voltage Wiring .....	44
Dimensions and Weights .....	17	Emergency Stop .....	44
Weights.....	17	External Auto/Stop.....	44
Service Clearance .....	18	External Circuit Lockout – Circuit #1 and #2 .....	44
Unit Dimensions.....	19	Ice Building Option .....	44
Installation Mechanical .....	23	External Chilled Water Setpoint (ECWS) Option .....	45
Location Requirements .....	23	External Demand Limit Setpoint (EDLS) Option .....	45
Sound Considerations.....	23	EDLS and ECWS Analog Input Signal Wiring .....	45
Foundation .....	23	Chilled Water Reset (CWR) .....	46
Clearances .....	23		
Lifting and Moving Instructions .....	23		
Center of Gravity .....	26		
Isolation and Sound Emission .....	26		
Unit Isolation and Leveling.....	26		
Elastomeric Isolators .....	26		

Transformer Power Rating .....	47	Seasonal Unit Start-up Procedure .....	68
Communications Interface .....	47	System Restart After Extended	
LonTalk Interface (LCI-C) .....	47	Shutdown .....	68
BACnet Interface (BCI-C).....	47	Sequence of Operation.....	69
Modbus Remote Terminal Unit		Software Operation Overview.....	69
Interface .....	47	Power Up Diagram .....	70
Operating Principles.....	48	Power Up to Starting .....	71
Refrigeration Circuits .....	48	Stopped to Starting .....	72
Refrigeration Cycle .....	48	Running (Lead Compressor/Circuit	
Refrigerant R-134a .....	48	Start and Run) .....	73
Compressor and Oil System.....	48	Running (Lag Compressor/Circuit	
Condenser and Fans .....	48	Start and Run) .....	74
Evaporator.....	49	Satisfied Setpoint.....	75
Drive Cooling System.....	49	Normal Shutdown to Stopped or	
Controls .....	50	Run Inhibit .....	76
Overview .....	50	Immediate Shutdown to Stopped or	
UC800 Specifications .....	50	Run Inhibit .....	77
Wiring and Port Descriptions.....	50	Ice Making (Running to Ice Making to	
Communication Interfaces.....	51	Running) .....	78
Rotary Switches .....	51	Ice Making (Auto to Ice Making to Ice	
LED Description and Operation.....	51	Making Complete) .....	79
Tracer AdaptiView TD7 Display .....	53	Maintenance .....	80
Operator Interface.....	53	Recommended Maintenance .....	80
Home Screen .....	53	Weekly.....	80
Viewing Chiller Operating		Monthly.....	81
Modes .....	53	Annual.....	81
Alarms.....	57	Refrigerant and Oil Charge	
Reports .....	57	Management .....	81
Equipment Settings .....	59	Lubrication System .....	81
Display Settings .....	61	Oil Sump Level Check .....	81
Security Settings.....	63	Drive Cooling System.....	82
InvisiSound Ultimate — Noise		Service Intervals .....	82
Reduction Mode .....	64	Unit Diagnostics .....	82
Tracer TU .....	64	pH Test.....	83
Integrated Rapid Restart.....	65	Pressure Relief Cap .....	83
Pre-Start.....	66	Drive Cooling Expansion Tank .....	83
Start-up and Shutdown.....	67	Condenser Coil Corrosion Protection	
Unit Start-up .....	67	Inspection.....	83
Temporary Shutdown And Restart .....	67	Condenser Coil Cleaning .....	83
Extended Shutdown Procedure .....	67	Coil Cleaning Interval .....	83
		Cleaning Air Side of Coils .....	84
		Cleaning Coated Coils .....	84
		Reinstallation of Compressor Mounting	
		Bolts .....	84



## Table of Contents

---

Servicing Chiller Roof .....	84	Unit Wiring .....	105
Diagnostics.....	85	Log and Check Sheets .....	106
General Diagnostics Information.....	85	Ascend™ Model ACR Installation Completion Check Sheet and Request for Trane Service .....	107
AFD Diagnostics.....	85	Operator Log .....	109
Main Processor Diagnostics .....	88		
Communication Diagnostics.....	100		



# Model Number Information

## Nameplates

Unit nameplates are applied to the exterior of the control panel. A compressor nameplate is located on each compressor. When the unit arrives, compare all nameplate data with ordering, submittal, and shipping information.

## Unit Nameplate

See figure below for a typical unit nameplate. The outdoor unit nameplate provides the following information:

- Unit model and size description.
- Unit serial number.
- Unit electrical requirements.
- Operating charges of R-134a and refrigerant oil (Trane OIL00311).
- Unit design pressures.
- Installation, operation and maintenance and service data literature.
- Drawing numbers for unit wiring diagrams

## Model Number Coding System

Model numbers are composed of numbers and letters that represent features of the equipment. Shown below is a sample of typical unit model number.

ACRA 200F UA01 AA1F N1X1 A2D0 0CB1 X03X AA01 000

Each position, or group of positions, in the model number is used to represent a feature. Unit model number digits are selected and assigned in accordance with the definitions as listed in Model Number Descriptions chapter. For example, position 08 of the unit model number above contains the letter "F" which indicates the unit voltage is 460/60/3.

## Compressor Nameplate

The compressor nameplate provides the following information:

- Compressor model number.
- Compressor serial number.
- Compressor electrical characteristics
- Utilization range.
- Recommended refrigerant

See Model Number Descriptions chapter for compressor model and serial number descriptions.



# Model Number Descriptions

## Unit Model Number

### Digit 1, 2, 3, 4 — Unit Model

**ACRA** = Air-Cooled Screw Chiller

### Digit 5, 6, 7 — Nominal Tonnage

**150** = 150 Tons  
**165** = 165 Tons  
**180** = 180 Tons  
**200** = 200 Tons  
**225** = 225 Tons  
**250** = 250 Tons  
**275** = 275 Tons  
**300** = 300 Tons

### Digit 8 — Unit Voltage

**A** = 200/60/3  
**B** = 230/50/3  
**C** = 380/50/3  
**D** = 380/60/3  
**E** = 400/50/3  
**F** = 460/60/3  
**G** = 575/60/3  
**H** = 400/60/3

### Digit 9 — Manufacturing Location

**U** = Trane Commercial Systems, Pueblo, CO USA

### Digits 10, 11 — Design Sequence

\*\* = Factory assigned

### Digit 12 — Unit Sound Package

**1** = InvisiSound™ Standard Unit  
**2** = InvisiSound™ Superior (Line Wraps, Reduced Fan Speed)  
**3** = InvisiSound™ Ultimate (Compressor Sound Attenuation, Line Wraps, Reduced Fan Speed)

### Digit 13 — Agency Listing

**0** = No Agency Listing  
**A** = UL/cUL Listing

### Digit 14 — Pressure Vessel Code

**A** = ASME Pressure Vessel Code  
**C** = CRN or Canadian Equivalent Pressure Vessel Code  
**D** = Australia Pressure Vessel Code

### Digit 15 — Factory Charge

**1** = Refrigerant Charge R-134a  
**2** = Nitrogen Charge

### Digit 16 — Evaporator Application

**F** = Standard Cooling (40 to 65°F/5.5 to 18°C)  
**G** = Low Temp Process Cooling (below 40°F/5.5°C)  
**C** = Ice Making (20 to 6°F/7 to 18°C) with Hardwired Interface

### Digit 17 — Evaporator Configuration

**N** = 2-pass Evaporator  
**P** = 3-pass Evaporator

### Digit 18 — Evaporator Fluid Type

**1** = Water  
**2** = Calcium Chloride  
**3** = Ethylene Glycol  
**4** = Propylene Glycol  
**5** = Methanol

### Digit 19 — Water Connection

**X** = Grooved Pipe  
**F** = Grooved Pipe + Flange

### Digit 20 — Flow Switch

**1** = Factory Installed - Other Fluid (15 cm/s)  
**2** = Factory Installed - Water 2 (35 cm/s)  
**3** = Factory Installed - Water 3 (45 cm/s)

### Digit 21 — Insulation

**A** = Factory Insulation — All Cold Parts 0.75"  
**B** = Evaporator-only Insulation for High Humidity/Low Evap Temp 1.25"

### Digit 22 — Unit Application

**1** = Standard Ambient (32 to 105°F/0 to 40.6°C)  
**2** = Low Ambient (0 to 105°F/-17.7 to 40.6°C)  
**3** = Extreme Low Ambient (-20 to 105°F/-28.9 to 40.6°C)  
**4** = High Ambient (32 to 125°F/0 to 52°C)  
**5** = Wide Ambient (0 to 125°F/-17.7 to 52°C)

### Digit 23 — Condenser Fin Options

**A** = Aluminum Fins with Slits  
**D** = CompleteCoat™ Epoxy Coated Fins

### Digit 24, 25 — Not Used

**00** = Reserved for future use

### Digit 26 — Power Line Connection Type

**A** = Terminal Block  
**C** = Circuit Breaker  
**D** = Circuit Breaker with High Fault Rated Control Panel

### Digit 27 — Short Circuit Current Rating

**A** = Default A Short Circuit Rating  
**B** = High A Short Circuit Rating

### Digit 28 — Transformer

**0** = No Transformer  
**1** = Factory Installed Transformer

### Digit 29 — Line Voltage Harmonic Mitigation

**X** = DC Reactors (~30% TDD)  
**1** = Filter circuit (IEEE519 Compliant)

### Digit 30 — Electrical Accessories

**0** = No Convenience Outlet  
**C** = 15A 115V Convenience Outlet (Type B)

### Digit 31 — Remote Communication Option

**0** = None  
**1** = LonTalk® Interface (LCI-C)  
**2** = BACnet® MS/TP Interface  
**3** = Modbus™ Interface

### Digit 32 — Hard Wire Communication

**X** = None  
**A** = Hard Wired Bundle - All  
**B** = Remote Leaving Water Temp Setpoint  
**C** = Remote Leaving Temp and Demand Limit Setpoints  
**D** = Programmable Relay  
**E** = Programmable Relay and Leaving Water and Demand Limit Setpoint  
**F** = Percent Capacity  
**G** = Percent Capacity and Leaving Water and Demand Limit Setpoint  
**H** = Percent Capacity and Programmable Relay



**Digit 33 – Not Used**

**A** = Reserved for future use

**Digit 34 – Structural Options**

**A** = Standard Unit Structure

**Digit 35 – Appearance Accessories**

**0** = No Appearance Options  
**A** = Architectural Louvered Panels

**Digit 36 – Unit Isolation**

**0** = None  
**1** = Elastomeric Isolators

**Digit 37, 38 – Not Used**

**00** = Reserved for future use

**Digit 39 – Special**

**0** = None  
**S** = Special  
**F** = Ship to Final Finisher



## Model Number Descriptions

---

### Compressor Information

#### Model Number

##### Digit 1, 2, 3, 4 – Compressor Type

**CHHS** = Positive displacement, helical rotary (twin screw) hermetic compressor

##### Digit 5 – Frame Size

**R** = R Frame: 70 - 100 tons

**S** = S Frame: 112 - 165 tons

##### Digit 6 – Motor Length

**B** = 145 mm

**C** = 170 mm

**E** = 165 mm

**F** = 190 mm

##### Digit 7 – Motor Winding Characteristics

**\*** = Factory assigned

##### Digit 8 – Volume Ratio

**E** = Variable Volume Ratio

##### Digit 9 – Refrigerant

**1** = R-134a

##### Digits 10, 11 – Design Sequence

**\*\*** = Factory assigned

### Serial Number

#### Digit 1, 2 – Year

**YY** = Last two digits of year of manufacture

#### Digit 3, 4 – Week

**WW** = Week of build, from 00 to 52

#### Digit 5 – Day

**1** = Monday

**2** = Tuesday

**3** = Wednesday

**4** = Thursday

**5** = Friday

**6** = Saturday

**7** = Sunday

#### Digit 6, 7, 8 – Coded Time Stamp

**TTT** = Used to ensure uniqueness of serial number

#### Digit 9 – Assembly Line

Assembly line compressor was built on. Varies with facility.

#### Digit 10 – Build Location

**A** = Monterrey



# General Information

## Unit Description

The Ascend™ ACR units are helical-rotary type, air-cooled chillers designed for outdoor installation. The refrigerant circuits are factory-piped, leak tested and dehydrated. Every unit is electrically tested for proper control operation before shipment.

Chilled water inlet and outlet openings are covered for shipment. The chiller features Trane's exclusive Adaptive Control™ logic, which monitors the control variables that govern the operation of the chiller unit. Adaptive Control logic can adjust capacity variables to avoid chiller shutdown when necessary, and keep producing chilled water. The units feature two independent refrigerant circuits. Each circuit utilizes at least one compressor driven by an Adaptive Frequency Drive. Each refrigerant circuit is provided with filter, sight glass, electronic expansion valve, and charging valves. The shell-and-tube evaporator is manufactured in accordance with the ASME standards or other international codes. Each evaporator is fully insulated and equipped with water drain and vent connections.

Units are shipped with full oil charge and can be ordered with either a factory refrigerant charge, or optional nitrogen charge.

## Unit Length

Units are EXTENDED length if either of the following are selected:

- Transformer: Model number digit 28 = 1
- Harmonic Filtration Option: Model number digit 29 = 1

Units without Harmonic Filtration Option or Transformer (digits 28, 29 = 0X) are STANDARD length.

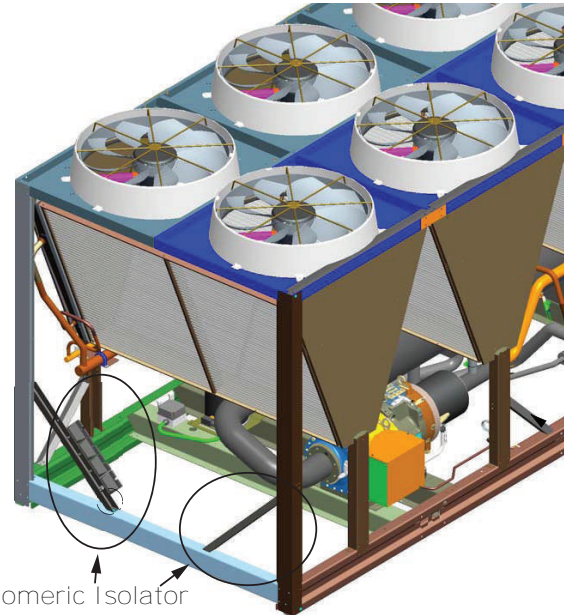
## Accessory/Option Information

Check all the accessories and loose parts which are shipped with the unit against the shipping list. Included in these items will be water vessel drain plugs, electrical diagrams, and service literature, which are placed inside the control panel for shipment.

If optional elastomeric isolators are ordered with unit (model number digit 36 = 1), they are shipped mounted

on diagonal supports on the end of the unit opposite control panel. See figures below.

**Figure 1. Elastomeric isolator shipping location**



Elastomeric Isolator Shipping Locations (not all isolators shown - quantity varies with unit configuration)

**Figure 2. Elastomeric isolators attached for shipping**





## General Information

# General Data

Table 1. General data table

Unit Size (tons)		150	165	180	200	225	250	275	300
Compressor Model		CHHSR	CHHSR	CHHSR	CHHSR	CHHSS	CHHSS	CHHSS	CHHSS
Quantity	#	2	2	2	2	2	2	2	2
<b>Evaporator</b>									
Water Storage	(gal)	17.5	18.7	21.9	23.9	26.6	28.7	33.0	36.0
	(L)	66.1	70.9	82.8	90.5	100.6	108.8	125.0	136.1
2 Pass arrangement									
Water Connection Size	(in)	5	5	6	6	6	6	8	8
	(mm)	125	125	150	150	150	150	200	200
Minimum Flow	(gpm)	171	187	202	228	261	288	318	354
	(l/s)	10.8	11.8	12.7	14.4	16.5	18.2	20.1	22.3
Maximum Flow	(gpm)	626	684	742	835	957	1055	1165	1299
	(l/s)	39.5	43.1	46.8	52.7	60.4	66.5	73.5	81.9
3 Pass arrangement									
Water Connection Size	(in)	4	4	5	5	5	5	6	6
	(mm)	100	100	125	125	125	125	150	150
Minimum Flow	(gpm)	114	124	135	152	174	192	212	236
	(l/s)	7.2	7.8	8.5	9.6	11.0	12.1	13.4	14.9
Maximum Flow	(gpm)	417	456	495	557	638	703	777	866
	(l/s)	26.3	28.8	31.2	35.1	40.2	44.3	49.0	54.6
<b>Condenser</b>									
Qty of Coils		8	10	10	12	12	12	14	16
Coil Length	(in)	78.74	78.74	78.74	78.74	78.74	78.74	78.74	78.74
	(mm)	2000	2000	2000	2000	2000	2000	2000	2000
Coil Height	(in)	50	50	50	50	50	50	50	50
	(mm)	1270	1270	1270	1270	1270	1270	1270	1270
Fins/Ft		192	192	192	192	192	192	192	192
Rows		3	3	3	3	3	3	3	3
<b>Condenser Fans</b>									
Quantity	#	8	10	10	12	12	12	14	16
Diameter	(in)	37.5	37.5	37.5	37.5	37.5	37.5	37.5	37.5
	(mm)	953	953	953	953	953	953	953	953
Total Airflow	(cfm)	107,392	134,240	134,240	161,088	161,088	161,088	187,936	214,784
	(m <sup>3</sup> /hr)	182,460	228,075	228,075	273,690	273,690	273,690	319,305	364,920
Tip Speed	(ft/min)	8700	8700	8700	8700	8700	8700	8700	8700
	(M/S)	44.2	44.2	44.2	44.2	44.2	44.2	44.2	44.2

**Table 1. General data table (continued)**

<b>Unit Size (tons)</b>		<b>150</b>	<b>165</b>	<b>180</b>	<b>200</b>	<b>225</b>	<b>250</b>	<b>275</b>	<b>300</b>
<b>Ambient Temperature Range</b>									
Standard Ambient	°F (°C)	32 to 105 (0 to 40.6)							
Low Ambient	°F (°C)	0 to 105 (-17.7 to 40.6)							
Extreme Low Ambient	°F (°C)	-20 to 105 (-28.9 to 40.6)							
High Ambient	°F (°C)	32 to 125 (0 to 52)							
Wide Ambient	°F (°C)	0 to 125 (-17.7 to 52)							
<b>General Unit</b>									
Refrigerant		HFC-134a							
Refrigerant Ckts	#	2							
Minimum Load	%	20	18	17	15	20	18	16	15
Refrigerant Charge/ckt	(lbs)	172	181	210	218	265	261	318	325
	(kg)	78	82	95	99	120	118	144	148
Oil		Trane OIL00311							
Oil Charge/ckt	(gal)	3.0	3.0	3.0	3.0	4.0	4.0	4.0	4.0
	(L)	11.4	11.4	11.4	11.4	15.1	15.1	15.1	15.1



General Information

Drive Cooling Fluid

**NOTICE**

**Equipment Damage!**  
 Use of unapproved fluids, or dilution of approved fluid, could result in catastrophic equipment damage.  
 Use only Trane Heat Transfer Fluid P/N CHM01023. This fluid is a direct use concentration and is not to be diluted. Do not top off with water or any other fluid.

*Note: The use of incorrect compounds in the drive cooling system may result in scaling, erosion, corrosion or freezing. The Trane Company warranty specifically excludes liability for corrosion, erosion, freezing or deterioration of Trane equipment.*

Proper fluid level is important to the operation of the unit. See Drive Cooling Expansion Tank section in Maintenance chapter for fluid level check instructions. The circuit capacities are shown in table below.

If the level is below the recommended minimum levels, contact your local Trane office.

*Note: Drive cooling fluid service life is 5 years. See maintenance chapter for more drive cooling system information.*

Table 2. Drive cooling

Unit Size (tons)	Voltage	Ambient <sup>(a)</sup>	Fluid Volume (gal)		Fluid Volume (l)	
			Ckt1	Ckt2	Ckt 1	Ckt2
Standard Length						
150 to 200	All	All	1.4	2.0	5.5	7.7
225 to 250	200/60, 230/50, 460/60, 575/60	Std, Low, Extra Low	1.4	2.0	5.5	7.7
		High, Wide	1.5	2.1	5.8	8.1
	380/60, 380/50, 400/50	All	1.5	2.1	5.8	8.1
275 to 300	All	All	1.5	2.1	5.8	8.1
Extended Length						
150 to 200	All	All	1.7	2.2	6.2	8.5
225 to 250	200/60, 230/50, 460/60, 575/60	Std, Low, Extra Low	1.7	2.2	6.2	8.5
		High, Wide	1.7	2.3	6.6	8.8
	380/60, 380/50, 400/50	All	1.7	2.3	6.6	8.8
275 to 300	All	All	1.7	2.3	6.6	8.8

<sup>(a)</sup> See model number description section, digit 22, for ambient information.



# Pre-Installation

## Unit Inspection

To protect against loss due to damage incurred in transit, perform inspection immediately upon receipt of the unit.

### Exterior Inspection

If the job site inspection reveals damage or material shortages, file a claim with the carrier immediately. Specify the type and extent of the damage on the bill of lading before signing. Notify the appropriate sales representative.

**Important:** *Do not proceed with installation of a damaged unit without sales representative's approval.*

- Visually inspect the complete exterior for signs of shipping damages to unit or packing material.
- Verify that the nameplate data matches the sales order and bill of lading.
- Verify that the unit is properly equipped and there are no material shortages.

**Note:** *Corrosion due to dirt, road grime, road salt, and other contaminants picked up during shipping is not the responsibility of the carrier.*

### Inspection for Concealed Damage

Visually inspect the components for concealed damage as soon as possible after delivery and before it is stored.

If concealed damage is discovered:

- Notify the carrier's terminal of the damage immediately by phone and by mail.
- Concealed damage must be reported within 15 days.
- Request an immediate, joint inspection of the damage with the carrier and consignee.
- Stop unpacking the unit.
- Do not remove damaged material from receiving location.
- Take photos of the damage, if possible.
- The owner must provide reasonable evidence that the damage did not occur after delivery.

## Repair

Notify the appropriate sales representative before arranging unit installation or repair.

**Important:** *Do not repair unit until the damage has been inspected by the carrier's representative.*

## Storage Requirements

Extended storage of outdoor unit prior to installation requires these precautionary measures:

- Store the outdoor unit in a secure area.
- For units that have been charged with refrigerant, verify the following valves are closed on each circuit:
  - Suction service valve (butterfly valve)
  - Liquid line angle valve or EXV (EXV is driven closed whenever circuit is powered)
  - Oil line shutoff valves to brazed plate heat exchangers

**Note:** *Units with factory refrigerant charge (model number digit 15 = 1) are shipped with suction, liquid and oil line shutoff valves closed, isolating most of refrigerant charge in the evaporator. If unit goes directly into long term storage, it is recommended that these valve positions be confirmed.*

- For units with nitrogen charge option (model number digit 15 = 2), units are shipped with valves open. If unit goes directly into storage prior to refrigerant charge, confirm all service valves are open.



- At least every three months (quarterly), check the pressure in the refrigerant circuits to verify that the refrigerant charge is intact. If it is not, contact a qualified service organization and the appropriate Trane sales office.



**Pre-Installation**

**Installation Requirements**

Type	Trane Supplied Trane Installed	Trane Supplied Field Installed	Field Supplied Field Installed
Foundation			<ul style="list-style-type: none"> <li>• Meet foundation requirements</li> </ul>
Rigging			<ul style="list-style-type: none"> <li>• Safety chains</li> <li>• Clevis connectors</li> <li>• Lifting beam</li> <li>• Spreader bar</li> </ul>
Disassembly/Reassembly (as required)	Trane, or an agent of Trane specifically authorized to perform start-up of Trane® products (contact your local Trane office for pricing)		
Isolation		Elastomeric isolators (optional)	<ul style="list-style-type: none"> <li>• Elastomeric isolators (optional)</li> </ul>
Electrical	<ul style="list-style-type: none"> <li>• Circuit breakers (optional)</li> <li>• Unit Mounted Starter</li> </ul>		<ul style="list-style-type: none"> <li>• Circuit breakers (optional)</li> <li>• Electrical connections to unit mounted starter</li> <li>• Wiring sizes per submittal and NEC</li> <li>• Terminal lugs</li> <li>• Ground connection(s)</li> <li>• Ground type specified (Center Ground-Y or not)</li> <li>• BAS wiring (optional)</li> <li>• Control voltage wiring</li> <li>• Chilled water pump contactor and wiring</li> <li>• Option relays and wiring</li> </ul>
Water piping	Flow switch		<ul style="list-style-type: none"> <li>• Taps for thermometers and gauges</li> <li>• Thermometers</li> <li>• Water flow pressure gauges</li> <li>• Isolation and balancing valves in water piping</li> <li>• Vents and drain</li> <li>• Waterside pressure relief valves</li> <li>• Water strainer</li> </ul>
Insulation	Insulation		Insulation
Water Piping Connection Components	Grooved pipe	Flange kit (optional)	
Other Materials	<ul style="list-style-type: none"> <li>• R-134a refrigerant</li> <li>• Dry nitrogen (optional)</li> </ul>		
Ascend™ Model ACR Installation Completion Check Sheet and Request for Trane Service (AC-ADF001*-EN) See Log and Check Sheet chapter			
Chiller Start-up Commissioning	Trane, or an agent of Trane specifically authorized to perform start-up of Trane® products		
Trane specifically authorized to perform start-up of Trane® products			





# Dimensions and Weights

## Weights

Table 3. Unit weights

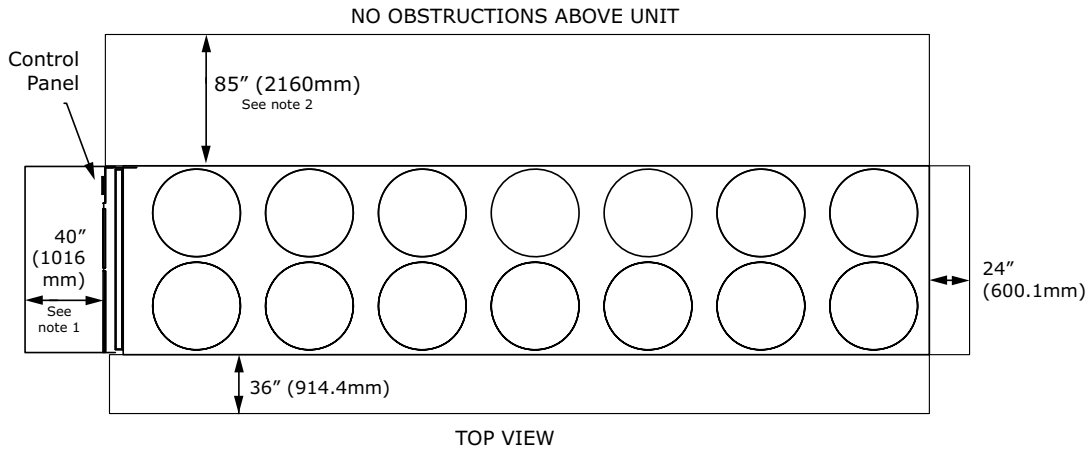
Unit Size (tons)	Standard Length				Extended Length			
	Shipping		Operating		Shipping		Operating	
	lb	kg	lb	kg	lb	kg	lb	kg
InvisiSound™ Standard or Superior								
150	11333	5141	11479	5207	13492	6120	13638	6186
165	12377	5614	12533	5685	14532	6592	14688	6662
180	12698	5760	12881	5843	14853	6737	15036	6820
200	13808	6263	14008	6354	15991	7254	16191	7344
225	15244	6915	15466	7015	17427	7905	17649	8006
250	15622	7086	15862	7195	17805	8076	18045	8185
275	16820	7630	17095	7754	18975	8607	19250	8732
300	17965	8149	18265	8285	20121	9127	20421	9263
InvisiSound™ Ultimate								
150	12133	5504	12279	5570	14292	6483	14438	6549
165	13177	5977	13333	6048	15332	6955	15488	7025
180	13498	6123	13681	6206	15653	7100	15836	7183
200	14608	6626	14808	6717	16791	7616	16991	7707
225	16044	7278	16266	7378	18227	8268	18449	8368
250	16422	7449	16662	7558	18605	8439	18845	8548
275	17620	7992	17895	8117	19775	8970	20050	9095
300	18765	8512	19040	8636	20921	9490	21196	9614

**Notes:**

1. Weights include factory charge of refrigerant and oil, as well as architectural louvered panels. See Unit Length section of General Data chapter to determine unit length.
2. Model number digit 12 = 1 or 2
3. Model number digit 12 = 3

## Service Clearance

**Figure 3. Unit service clearance requirements**



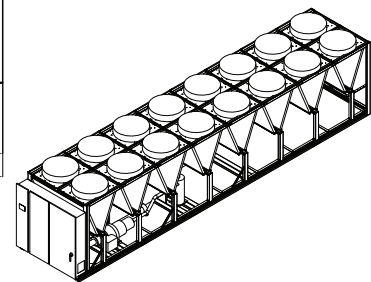
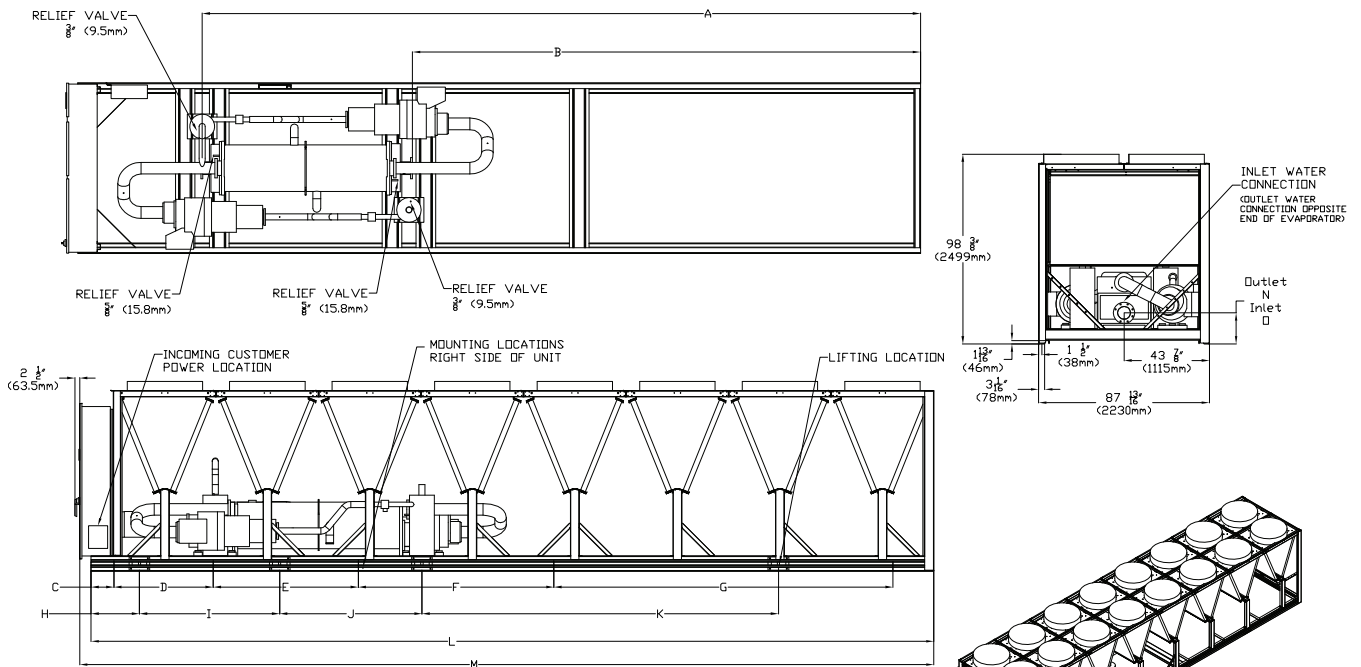
**Notes:**

1. A full 40" clearance is required in front of the control panel. Must be measured from front of panel, not end of unit base.
2. Clearance of 85" on the side of the unit is required for coil replacement. Preferred side for coil replacement is shown (left side of the unit, as facing control panel), however either side is acceptable.

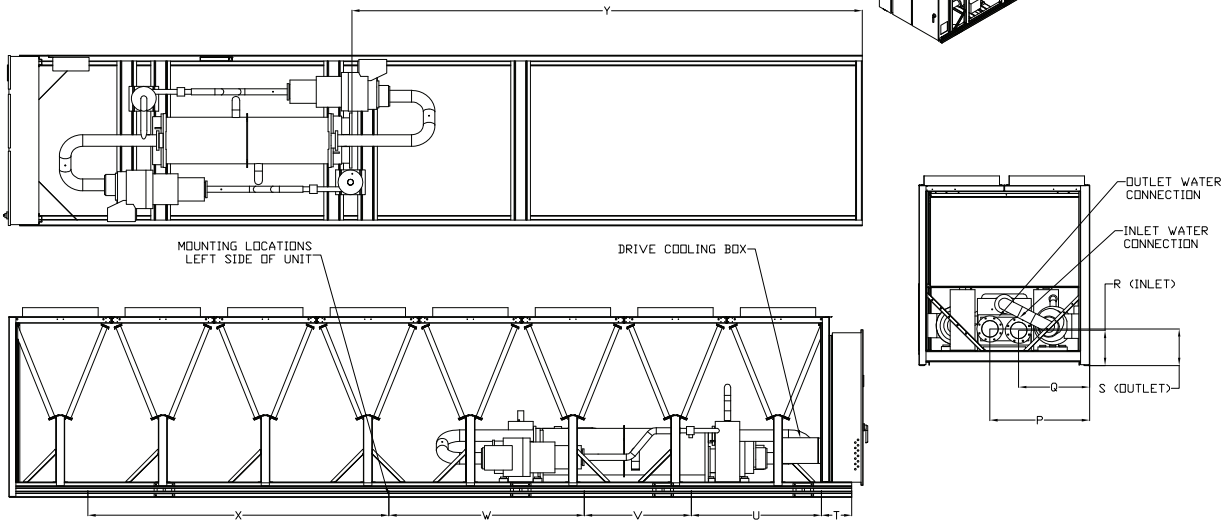
# Unit Dimensions

Figure 4. Unit dimensions, standard length

## 3 PASS OPTION



## 2 PASS OPTION



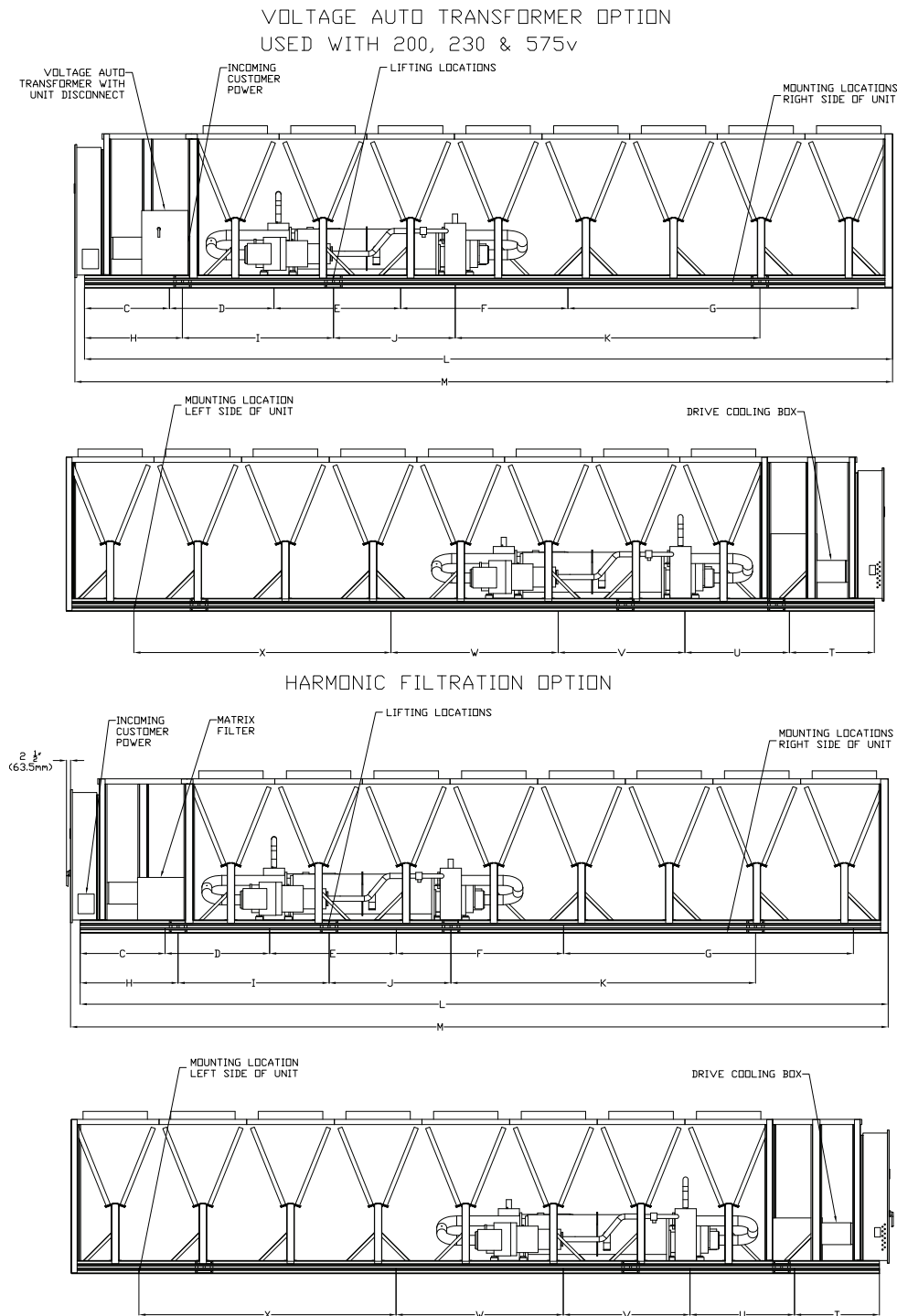


# Dimensions and Weights

**Table 4. Unit dimensions, standard length**

Dim	Unit Size													
	150		165		180		200		225, 250		275		300	
	in	mm	in	mm	in	mm	in	mm	in	mm	in	mm	in	mm
A	158.6	4027.0	211.4	5368.8	212.5	5397.4	265.3	6739.5	265.3	6739.5	318.1	8080.5	370.9	9422.5
B	52.4	1330.0	105.2	2671.9	103.5	2629.4	156.4	3971.5	156.4	3971.5	209.0	5308.5	261.8	6650.5
C	11.8	300.0	11.8	300.0	11.8	300.0	11.8	300.0	11.8	300.0	11.8	300.0	11.8	300.0
D	51.2	1300.0	51.2	1300.0	51.2	1300.0	51.2	1300.0	51.2	1300.0	51.2	1300.0	51.2	1300.0
E	78.8	2000.0	74.8	1900.0	74.8	1900.0	74.8	1900.0	74.8	1900.0	61.4	1560.0	74.8	1900.0
F	63.0	1600.0	118.1	3000.0	118.1	3000.0	100.8	2560.0	100.8	2560.0	72.4	1840.0	100.8	2560.0
G							76.4	1940.0	76.4	1940.0	137.8	3500.0	174.8	4440.0
H	25.0	635.0	25.0	635.0	25.0	635.0	25.0	635.0	25.0	635.0	25.0	635.0	25.0	635.0
I	128.1	3255.0	145.6	3699.0	145.6	3699.0	65.9	1674.0	65.9	1674.0	65.9	1674.0	65.9	1674.0
J							120.5	3061.0	120.5	3061.0	158.5	4026.0	79.7	2024.0
K													184.5	4686.0
L	223.0	5663.5	275.8	7005.5	275.8	7005.5	328.6	8347.5	328.6	8347.5	381.5	9689.5	434.3	11031.5
M	228.9	5813.0	281.7	7155.0	281.7	7155.0	334.5	8497.0	334.5	8497.0	387.4	9839.0	440.2	11181.0
N	20.4	519.5	20.4	519.5	19.6	497.5	19.6	497.5	19.6	497.5	21.8	553.6	20.6	522.5
O	17.7	449.5	17.7	449.5	15.4	390.5	15.4	390.5	15.4	390.5	17.6	446.6	16.1	407.7
P	49.3	1252.5	49.3	1252.5	49.9	1268.0	49.9	1268.0	49.9	1268.0	51.3	1303.3	51.3	1303.3
Q	38.5	977.5	38.5	977.5	37.9	962.0	37.9	962.0	37.9	962.0	36.5	927.3	36.5	927.3
R	19.3	489.5	19.3	489.5	17.6	447.5	17.6	447.5	19.8	503.6	18.2	462.5	18.2	462.5
S	19.7	499.5	19.7	499.5	18.2	462.5	18.2	462.5	20.4	518.6	18.9	480.5	18.9	480.5
T	15.8	400.0	15.8	400.0	15.8	400.0	15.8	400.0	15.8	400.0	15.8	400.0	15.8	400.0
U	66.9	1700.0	66.9	1700.0	66.9	1700.0	66.9	1700.0	66.9	1700.0	66.9	1700.0	66.9	1700.0
V	59.1	1500.0	55.1	1400.0	55.1	1400.0	55.1	1400.0	55.1	1400.0	41.8	1060.0	55.1	1400.0
W	63.0	1600.0	118.1	3000.0	118.1	3000.0	100.8	2560.0	100.8	2560.0	72.4	1840.0	100.8	2560.0
X							76.4	1940.0	76.4	1940.0	137.8	3500.0	155.1	3940.0
Y	53.6	1362.5	106.5	2704.4	105.5	2679.4	158.3	4021.5	158.3	4021.5	210.3	5340.0	263.1	6682.0

**Figure 5. Unit dimensions, extended length**



**Table 5. Unit dimensions, extended length**

Dim	Unit Size													
	150		165		180		200		225, 250		275		300	
	in	mm	in	mm	in	mm	in	mm	in	mm	in	mm	in	mm
A	158.6	4027.0	211.4	5368.8	212.5	5397.4	265.3	6739.5	265.3	6739.5	318.1	8080.5	370.9	9422.5
B	52.4	1330.0	105.2	2671.9	103.5	2629.4	156.4	3971.5	156.4	3971.5	209.0	5308.5	261.8	6650.5
C	27.6	700.0	27.6	700.0	27.6	700.0	51.2	1300.0	51.2	1300.0	51.2	1300.0	51.2	1300.0
D	86.6	2200.0	86.6	2200.0	86.6	2200.0	63.0	1600.0	63.0	1600.0	63.0	1600.0	63.0	1600.0
E	80.4	2042.0	76.4	1942.0	76.4	1942.0	76.4	1942.0	76.4	1942.0	63.1	1602.0	76.4	1942.0
F	63.0	1600.0	118.1	3000.0	118.1	3000.0	59.1	1500.0	59.1	1500.0	72.4	1840.0	100.8	2560.0
G							118.1	3000.0			137.8	3500.0	174.8	4440.0
H	55.1	1400.0	55.1	1400.0	55.1	1400.0	58.3	1482.0	58.3	1482.0	58.3	1482.0	58.3	1482.0
I	150.9	3832.0	168.4	4276.0	168.4	4276.0	85.4	2169.0	85.4	2169.0	85.4	2169.0	85.4	2169.0
J							120.5	3061.0			158.5	4026.0	79.7	2024.0
K													184.5	4686.0
L	275.8	7005.5	328.6	8347.5	328.6	8347.5	381.5	9689.5	381.5	9689.5	434.3	11031.5	487.1	12373.5
M	281.7	7155.0	334.5	8497.0	334.5	8497.0	387.4	9839.0	387.4	9839.0	440.2	11181.0	493.0	12523.0
N	20.4	519.5	20.4	519.5	19.6	497.5	19.6	497.5	19.6	497.5	20.6	522.5	20.6	522.5
O	17.7	449.5	17.7	449.5	15.4	390.5	15.4	390.5	17.6	446.6	16.1	407.7	16.1	407.7
P	49.3	1252.5	49.3	1252.5	49.9	1268.0	49.9	1268.0	49.9	1268.0	51.3	1303.3	51.3	1303.3
Q	38.5	977.5	38.5	977.5	37.9	962.0	37.9	962.0	37.9	962.0	36.5	927.3	36.5	927.3
R	19.3	489.5	19.3	489.5	17.6	447.5	17.6	447.5	19.8	503.6	18.2	462.5	18.2	462.5
S	19.7	499.5	19.7	499.5	18.2	462.5	18.2	462.5	20.4	518.6	18.9	480.5	18.9	480.5
T	27.6	700.0	27.6	700.0	27.6	700.0	51.2	1300.0	51.2	1300.0	51.2	1300.0	51.2	1300.0
U	86.6	2200.0	86.6	2200.0	86.6	2200.0	63.0	1600.0	63.0	1600.0	63.0	1600.0	63.0	1600.0
V	80.4	2042.0	76.4	1942.0	76.4	1942.0	76.4	1942.0	76.4	1942.0	63.1	1602.0	76.4	1942.0
W	63.0	1600.0	118.1	3000.0	118.1	3000.0	59.1	1500.0	59.1	1500.0	72.4	1840.0	63.0	1600.0
X							118.1	3000.0			137.8	3500.0	155.1	3940.0
Y	53.6	1362.5	106.5	2704.4	105.5	2679.4	158.3	4021.5	158.3	4021.5	210.3	5340.0	263.1	6682.0



# Installation Mechanical

## Location Requirements

### Sound Considerations

- Locate the unit away from sound-sensitive areas.
- Install the optional elastomeric isolators under the unit. See Isolation and Sound Emission section.
- Chilled water piping should not be supported by chiller frame.
- Install rubber vibration isolators in all water piping.
- Use flexible electrical conduit.
- Seal all wall penetrations.

**Note:** Consult an acoustical engineer for critical applications.

### Foundation

Provide rigid, non-warping mounting pads or a concrete foundation of sufficient strength and mass to support the applicable operating weight (i.e., including completed piping, and full operating charges of refrigerant, oil and water). See Dimensions and Weights chapter for unit operating weights. Once in place, the unit must be level within 1/4" (6.4 mm) across the length and width of the unit. The Trane Company is not responsible for equipment problems resulting from an improperly designed or constructed foundation.

### Clearances

Provide enough space around the unit to allow the installation and maintenance personnel unrestricted access to all service points. See submittal drawings for the unit dimensions, to provide sufficient clearance for the opening of control panel doors and unit service. See Dimensions and Weights chapter for minimum clearances. In all cases, local codes which require additional clearances will take precedence over these recommendations.

For close spacing information, see AC-PRB001\*-EN.

## Lifting and Moving Instructions

### ⚠ WARNING

#### Heavy Object!

Failure to follow instructions below could result in unit dropping which could result in death or serious injury, and equipment or property-only damage.

Ensure that all the lifting equipment used is properly rated for the weight of the unit being lifted. Each of the cables (chains or slings), hooks, and shackles used to lift the unit must be capable of supporting the entire weight of the unit. Lifting cables (chains or slings) may not be of the same length. Adjust as necessary for even unit lift.

### ⚠ WARNING

#### Improper Unit Lift!

Failure to properly lift unit in a LEVEL position could result in unit dropping and possibly crushing operator/technician which could result in death or serious injury, and equipment or property-only damage.

Test lift unit approximately 24 inches (61 cm) to verify proper center of gravity lift point. To avoid dropping of unit, reposition lifting point if unit is not level.

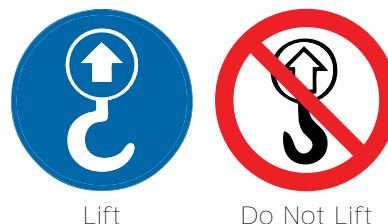
### ⚠ WARNING

#### Proper Lifting Configuration Required!

Failure to follow instructions below could cause the unit to drop which could result in death, serious injury or equipment damage.

Use ONLY lifting locations designated with label shown below. DO NOT use locations marked with do-not-lift label. See following figures for acceptable lifting configuration, and refer to labels on the unit.

Figure 6. Lift/Do Not Lift labels



**NOTICE****Equipment Damage!**

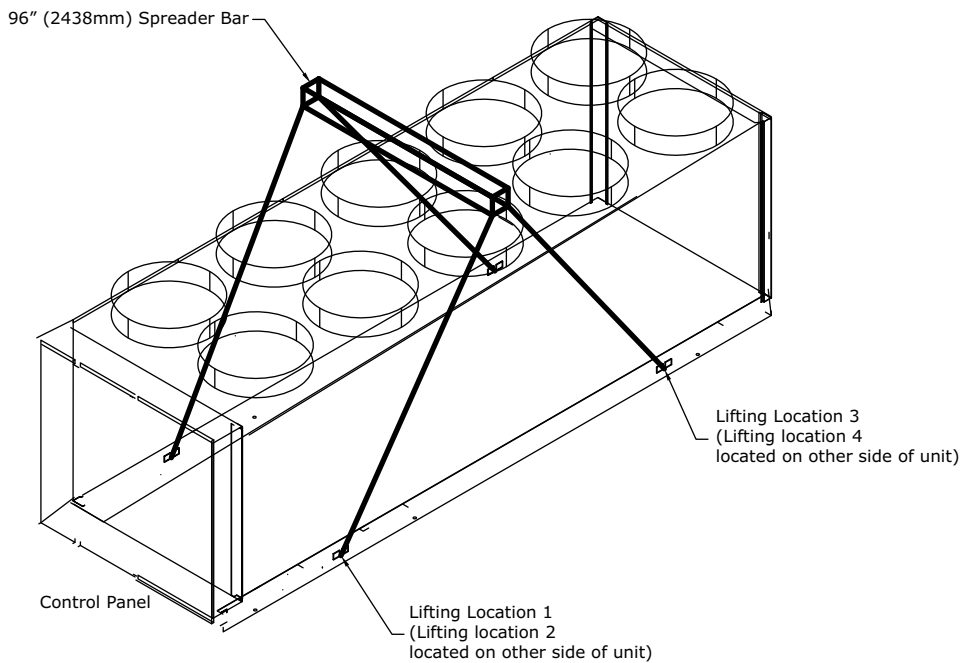
Moving the chiller using a fork lift could result in equipment or property-only damage.

**Do not use a fork lift to move the chiller!**

**Important:**

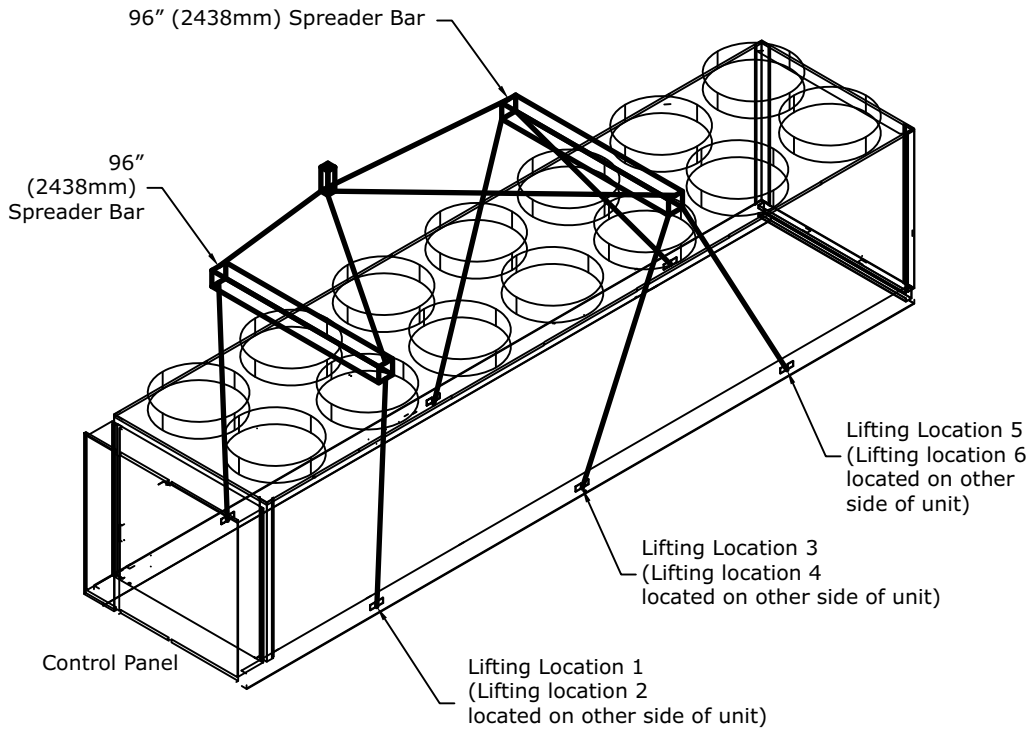
- See unit nameplate and/or unit submittal for total shipping weight.
- See following figures for unit lifting configuration.
- See *Dimensions and Weights* chapter, or unit submittal, for lifting point locations.
- See *Center of Gravity* section for more information.

**Figure 7. 4-point lift configuration — 150, 160, 180 ton units**

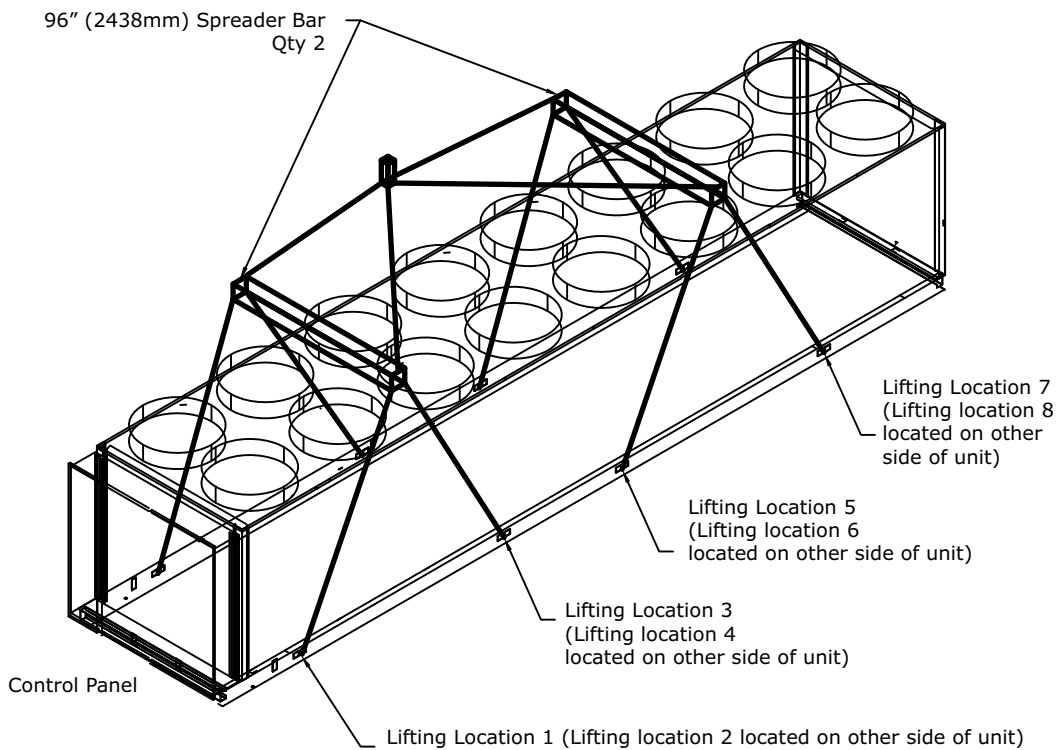




**Figure 8. 6-point lift configuration – 200, 225, 250, 275 ton units**



**Figure 9. 8-point lift configuration – 300 ton units**



## Center of Gravity

Figure 10. Center of gravity

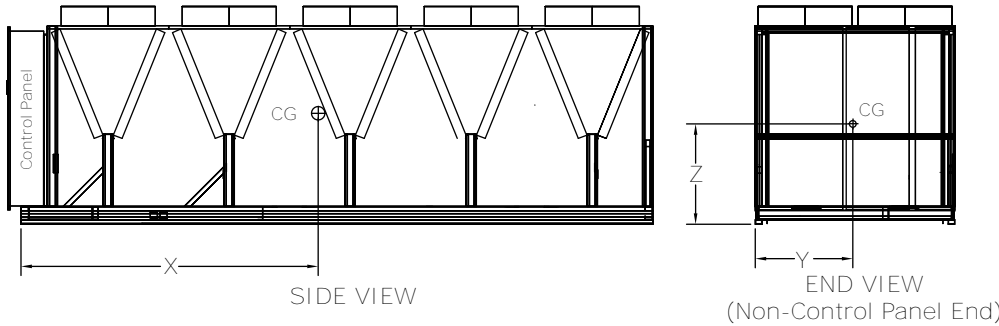


Table 6. Center of gravity dimensions

Unit Size	CGx		CGy		CGz		CGx		CGy		CGz	
	in	mm	in	mm	in	mm	in	mm	in	mm	in	mm
	Standard Length Unit						Extended Length Unit					
150	93.9	2384	44.2	1122	44.2	1124	128.2	3255	44.0	1118	43.3	1100
165	105.8	2686	44.2	1122	45.9	1166	139.1	3532	44.2	1124	44.9	1142
180	106.0	2691	44.5	1131	45.6	1159	139.6	3545	44.5	1129	44.7	1135
200	114.1	2898	44.1	1121	47.2	1199	147.2	3738	44.2	1124	46.3	1175
225	115.8	2941	44.1	1120	45.2	1148	148.8	3780	44.2	1122	44.4	1129
250	115.1	2924	44.1	1120	45.6	1158	149.0	3785	44.1	1121	44.8	1139
275	127.7	3242	44.0	1117	46.1	1172	162.3	4122	44.2	1122	45.4	1153
300	139.5	3544	44.0	1116	47.1	1197	174.3	4427	43.8	1113	46.4	1178

## Isolation and Sound Emission

The most effective form of isolation is to locate the unit away from any sound sensitive area. Structurally transmitted sound can be reduced by elastomeric vibration eliminators. Spring isolators are not recommended. Consult an acoustical engineer in critical sound applications.

For maximum isolation effect, isolate water lines and electrical conduit. Wall sleeves and rubber isolated piping hangers can be used to reduce the sound transmitted through water piping. To reduce the sound transmitted through electrical conduit, use flexible electrical conduit.

State and local codes on sound emissions should always be considered. Since the environment in which a sound source is located affects sound pressure, unit placement must be carefully evaluated. Sound power levels for Stealth chillers are available on request.

### Unit Isolation and Leveling

For additional reduction of sound and vibration, install the optional elastomeric isolators.

Construct an isolated concrete pad for the unit or provide concrete footings at the unit mounting points.

Mount the unit directly to the concrete pads or footings.

Level the unit using the base rail as a reference. The unit must be level within 1/4" (6.4 mm) over the entire length and width. Use shims as necessary to level the unit.

### Elastomeric Isolators

**Note:** See unit submittal, or tables in this section, for point weights, isolator locations and isolator selections.

1. Secure the isolators to the mounting surface using the mounting slots in the isolator base plate. Do not fully tighten the isolator mounting bolts at this time.
2. Align the mounting holes in the base of the unit with the threaded positioning pins on the top of the isolators.
3. Lower the unit onto the isolators and secure the isolator to the unit with a nut.
4. Level the unit carefully. Fully tighten the isolator mounting bolts.

Figure 11. Elastomeric isolator

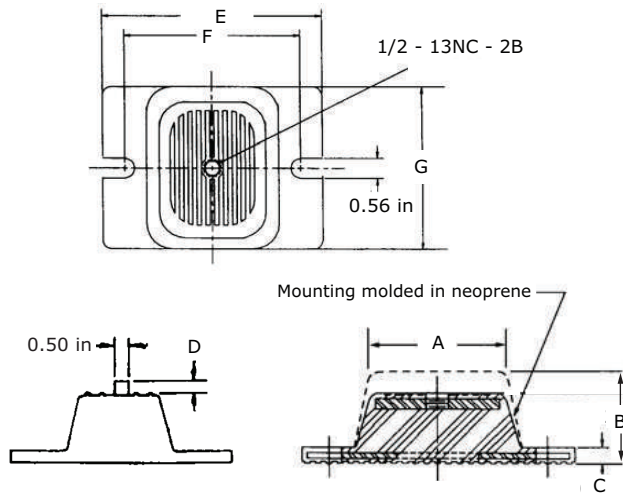


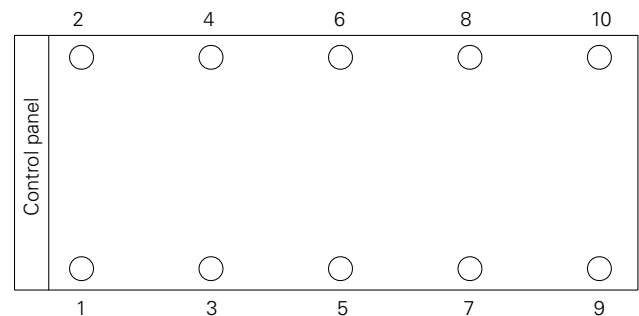
Table 7. Elastomeric isolator specifications

Isolator	Max Load (lbs)	Max Deflection (in)	A	B	C	D	E	F	G	Type
Black 60	1100	0.5	2.5	2.88	0.25	1.13	5.50	4.12	3.38	RDP3-WR
Brown 61	1500	0.5	3.0	2.75	0.38	1.60	6.25	5.00	4.63	RDP4-WR
Red 62	2250	0.5	3.0	2.75	0.38	1.60	6.25	5.00	4.63	RDP4-WR
Green 63	3000	0.5	3.0	2.75	0.38	1.60	6.25	5.00	4.63	RDP4-WR
Black 64	4000	0.5	3.0	2.75	0.38	1.60	6.25	5.00	4.63	RDP4-WR

### Mounting Locations, Weights, Isolators

See figure below for mounting point location designs.

Figure 12. Mounting point locations (top view)



**Note:** Quantity of isolators varies with unit. See submittal for actual number required for specific unit.

### Point Weights

Table 8. Point weights, units with InvisiSound standard or superior option - I-P (lb)

Unit Size	Point Weights (lb)									
	1	2	3	4	5	6	7	8	9	10
Standard Length Units										
150	1818	1609	1698	1515	1553	1623	731	932		
165	1752	1710	1749	1692	1783	1807	941	1099		
180	1774	1757	1787	1769	1827	1890	952	1124		



## Installation Mechanical

**Table 8. Point weights, units with InvisiSound standard or superior option - I-P (lb) (continued)**

Unit Size	Point Weights (lb)									
	1	2	3	4	5	6	7	8	9	10
200	1777	1823	1795	1702	1764	1748	1501	1636	126	136
225	1966	1882	2056	1952	1967	1984	1595	1816	113	135
250	2014	1939	2130	2025	2033	2041	1609	1827	111	133
275	1942	1845	1982	1859	1908	1880	1832	2023	870	954
300	1991	1934	2213	2114	2227	2179	1951	2053	741	862
Extended Length Units										
150	2268	2021	2073	1887	1724	1918	739	1008		
165	2181	1966	2155	2046	2178	2429	768	965		
180	2147	1936	2228	2087	2270	2620	771	977		
200	2583	2375	2208	2134	1894	2097	736	861	610	693
225	2806	2479	2474	2322	2096	2367	785	969	610	741
250	2844	2519	2558	2403	2173	2445	801	982	597	723
275	2699	2394	2487	2352	2367	2607	994	1204	1013	1133
300	2888	2488	2651	2450	2168	2356	1820	2090	708	802

**Table 9. Point weights, units with InvisiSound standard or superior option - SI (kg)**

Unit Size	Point Weight (kg)									
	1	2	3	4	5	6	7	8	9	10
Standard Length Units										
150	824	730	770	687	704	736	332	423		
165	794	775	793	767	809	820	427	499		
180	804	797	810	802	829	857	432	510		
200	806	827	814	772	800	793	681	742	57	62
225	892	854	932	885	892	900	723	824	51	61
250	913	879	966	918	922	926	730	828	51	60
275	881	837	899	843	865	853	831	917	395	433
300	903	877	1004	959	1010	988	885	931	336	391
Extended Length Units										
150	1029	916	940	856	782	870	335	457		
165	989	892	977	928	988	1102	348	437		
180	974	878	1010	946	1029	1188	350	443		
200	1172	1077	1001	968	859	951	334	390	277	314
225	1272	1124	1122	1053	951	1073	356	439	277	336
250	1290	1142	1160	1090	985	1109	363	445	271	328
275	1224	1086	1128	1067	1073	1182	451	546	459	514
300	1310	1128	1202	1111	983	1068	825	948	321	364

**Table 10. Point weights, units with InvisiSound ultimate option - I-P (lb)**

Unit Size	Point Weights (lb)									
	1	2	3	4	5	6	7	8	9	10
Standard Length Units										
150	1818	1609	1898	1715	1753	1823	731	932		

**Table 10. Point weights, units with InvisiSound ultimate option - I-P (lb) (continued)**

Unit Size	Point Weights (lb)									
	1	2	3	4	5	6	7	8	9	10
165	1752	1710	1949	1892	1983	2007	941	1099		
180	1774	1757	1988	1969	2027	2090	952	1124		
200	1777	1823	1995	1902	1964	1948	1501	1636	126	136
225	1966	1882	2256	2152	2167	2184	1595	1816	113	135
250	2014	1939	2330	2225	2233	2241	1609	1827	111	133
275	1942	1845	2182	2059	2108	2080	1832	2023	870	954
300	1991	1934	2407	2308	2420	2373	1951	2053	741	862
	Extended Length Units									
150	2268	2021	2273	2087	1924	2118	739	1008		
165	2181	1966	2355	2246	2378	2629	768	965		
180	2147	1936	2428	2287	2470	2820	771	977		
200	2583	2375	2408	2334	2094	2297	736	861	610	693
225	2806	2479	2674	2522	2296	2567	785	969	610	741
250	2844	2519	2758	2603	2373	2645	801	982	597	723
275	2699	2394	2687	2552	2567	2807	994	1204	1013	1133
300	2888	2488	2845	2643	2362	2550	1820	2090	708	802

**Table 11. Point weights, units with InvisiSound ultimate option - SI (kg)**

Unit Size	Point Weight (kg)									
	1	2	3	4	5	6	7	8	9	10
	Standard Length Units									
150	824	730	861	778	795	827	332	423		
165	794	775	884	858	899	910	427	499		
180	804	797	902	893	919	948	432	510		
200	806	827	905	863	891	883	681	742	57	62
225	892	854	1023	976	983	990	723	824	51	61
250	913	879	1057	1009	1013	1016	730	828	51	60
275	881	837	990	934	956	943	831	917	395	433
300	903	877	1092	1047	1098	1076	885	931	336	391
	Extended Length Units									
150	1029	916	1031	946	873	961	335	457		
165	989	892	1068	1019	1078	1192	348	437		
180	974	878	1101	1037	1120	1279	350	443		
200	1172	1077	1092	1059	950	1042	334	390	277	314
225	1272	1124	1213	1144	1041	1164	356	439	277	336
250	1290	1142	1251	1180	1076	1200	363	445	271	328
275	1224	1086	1219	1157	1164	1273	451	546	459	514
300	1310	1128	1290	1199	1071	1156	825	948	321	364

### Isolator Selections

See Dimensions and Weights chapter for isolator mounting position dimensions.

**Table 12. Elastomeric isolator selections**

Unit Size	Isolator Position									
	1	2	3	4	5	6	7	8	9	10
Standard Length Units										
150	Green 63	Green 63	Green 63	Green 63	Green 63	Green 63	Brown 61	Brown 61	-	-
165	Green 63	Green 63	Green 63	Green 63	Green 63	Green 63	Red 62	Red 62	-	-
180	Green 63	Green 63	Green 63	Green 63	Green 63	Green 63	Red 62	Red 62	-	-
200	Green 63	Green 63	Green 63	Green 63	Green 63	Green 63	Green 63	Green 63	Black 60	Black 60
225	Green 63	Green 63	Green 63	Green 63	Green 63	Green 63	Green 63	Green 63	Black 60	Black 60
250	Green 63	Green 63	Green 63	Green 63	Green 63	Green 63	Green 63	Green 63	Black 60	Black 60
275	Green 63	Green 63	Green 63	Green 63	Green 63	Green 63	Green 63	Green 63	Brown 61	Brown 61
300	Green 63	Green 63	Green 63	Green 63	Green 63	Green 63	Green 63	Green 63	Brown 61	Brown 61
Extended Length Units										
150	Green 63	Green 63	Green 63	Green 63	Green 63	Green 63	Brown 61	Brown 61	-	-
165	Black 64	Black 64	Black 64	Black 64	Black 64	Black 64	Brown 61	Brown 61	-	-
180	Black 64	Black 64	Black 64	Black 64	Black 64	Black 64	Brown 61	Brown 61	-	-
200	Black 64	Black 64	Black 64	Black 64	Black 64	Black 64	Brown 61	Brown 61	Brown 61	Brown 61
225	Black 64	Black 64	Black 64	Black 64	Black 64	Black 64	Brown 61	Brown 61	Brown 61	Brown 61
250	Black 64	Black 64	Black 64	Black 64	Black 64	Black 64	Brown 61	Brown 61	Brown 61	Brown 61
275	Black 64	Black 64	Black 64	Black 64	Black 64	Black 64	Brown 61	Brown 61	Brown 61	Brown 61
300	Black 64	Black 64	Black 64	Black 64	Black 64	Black 64	Black 64	Black 64	Brown 61	Brown 61

## Compressor Mounting Bolt Removal

Units with InvisiSound™ Ultimate Option (Model Number Digit 12 = 3)

For chillers built with InvisiSound Ultimate option, compressor mounting bolts must be removed to assure minimum noise during operation. Use a 24mm socket to remove the (3) M15 x 75mm mounting bolts for each compressor. They are located under compressor mounting feet. See figure below.

**Important:**

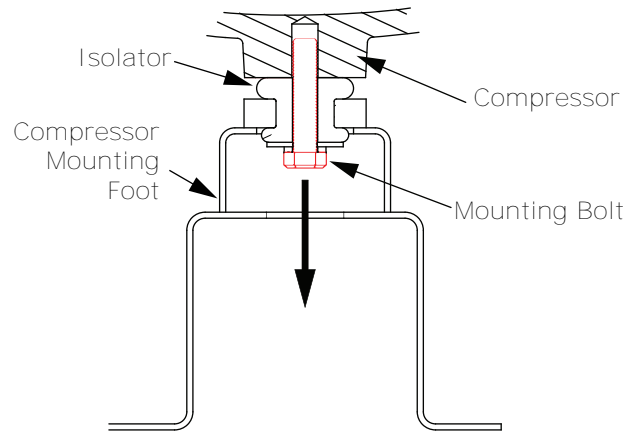
- *DO NOT DISCARD MOUNTING BOLTS. Store bolts in the control panel for future use.*
- *All mounting bolts MUST be reinstalled prior to compressor removal or unit move.*

### NOTICE

#### Equipment Damage!

Failure to reinstall bolts could cause shifting of parts and result in equipment damage. Do not remove compressor or move unit without reattaching compressor mounting bolts.

**Figure 13. Compressor mounting bolt removal**



## Drainage

Locate the unit near a large capacity drain for water vessel drain-down during shutdown or repair. Evaporators are provided with drain connections. A vent on top of evaporator waterbox prevents vacuum by allowing air into evaporator for complete drainage. All local and national codes apply.

## Refrigerant Pressure Relief Valves

Qty	Relief Valve Setting (psig)	Rated Capacity (lba/min)	Connection Size (in)	
			Field (Pipe)	Factory (Shell)
Evaporator				
2	200	17.3	5/8	7/8-14

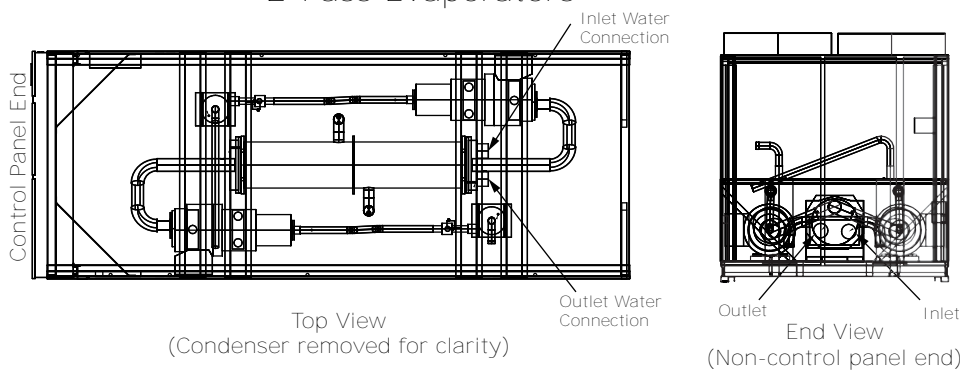
Qty	Relief Valve Setting (psig)	Rated Capacity (lba/min)	Connection Size (in)	
			Field (Pipe)	Factory (Shell)
Oil Separator				
2	350	6.3	5/8	1/4-18

## Evaporator Piping

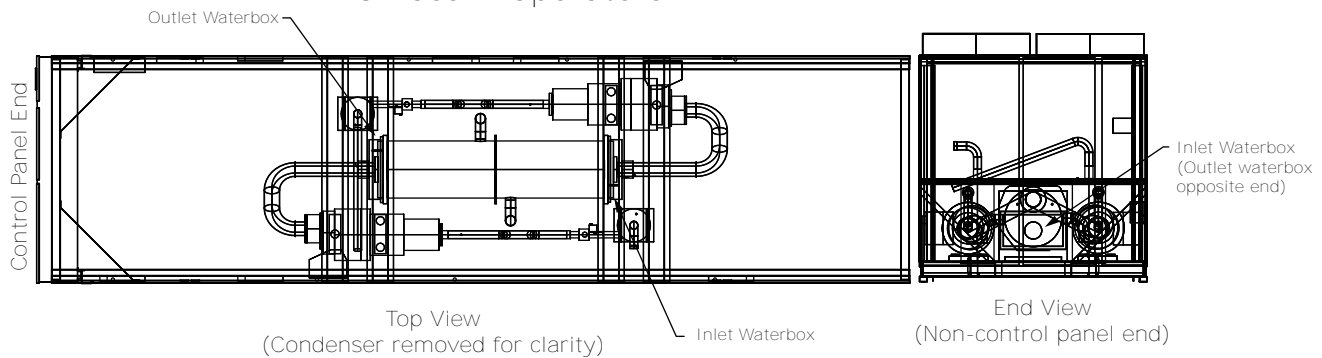
Units are available with two or three pass configurations.

Figure 14. Evaporator pass configurations

### 2-Pass Evaporators



### 3-Pass Evaporators



### NOTICE

#### Proper Water Treatment Required!

The use of untreated or improperly treated water could result in scaling, erosion, corrosion, algae or slime.

Use the services of a qualified water treatment specialist to determine what water treatment, if any, is required. Trane assumes no responsibility for equipment failures which result from untreated or improperly treated water, or saline or brackish water.

### NOTICE

#### Evaporator Damage!

Failure to follow instructions below could cause damage to the evaporator.

The chilled water connections to the evaporator are to be "victaulic" type connections. Do not attempt to weld these connections, as the heat generated from welding can cause microscopic and macroscopic fractures on the cast iron waterboxes that can lead to premature failure of the waterbox. To prevent damage to chilled water components, do not allow evaporator pressure (maximum working pressure) to exceed 150 psig (10.5 bar).

## Installation Mechanical

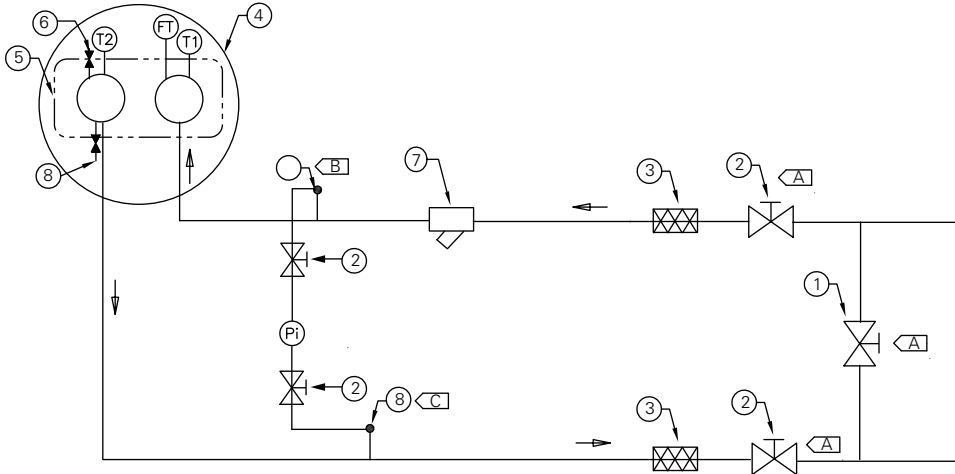
- Evaporator water connections are grooved.
- Thoroughly flush all water piping to the unit before making the final piping connections to the unit.
- Components and layout will vary slightly, depending on the location of connections and the water source.
- A vent is provided on the top of the evaporator at the chilled water inlet. Be sure to provide additional vents at high points in the piping to bleed air from the chilled water system. Install necessary pressure gauges to monitor the entering and leaving chilled water pressures.
- Provide shutoff valves in lines to the gauges to isolate them from the system when they are not in use. Use rubber vibration eliminators to prevent vibration transmission through the water lines.

- If desired, install thermometers in the lines to monitor entering and leaving water temperatures.
- Install a balancing valve in the leaving water line to control water flow balance.
- Install shutoff valves on both the entering and leaving water lines so that the evaporator can be isolated for service.

### Evaporator Piping Components

Piping components include all devices and controls used to provide proper water system operation and unit operating safety. These components and their general locations are given below.

**Figure 15. Typical water piping components**



Item	Description	Item	Description
1	Bypass Valve	Pi	Pressure Gauge
2	Isolation Valve	FT	Water Flow Switch
3	Vibration Eliminator	T1	Evap Water Inlet Temp Sensor
4	Evaporator - End View (2-pass)	T2	Evap Water Outlet Temp Sensor
5	Evaporator Waterbox (2-pass)	<b>NOTES</b>	
6	Vent	A	Isolate unit for initial water loop cleaning
7	Strainer	B	Vent must be installed at the high point of the line
8	Drain	C	Drain must be installed at the low point of the line

### Entering Chilled Water Piping

- Air vents (to bleed air from system).
- Water pressure gauges with shutoff valves.
- Vibration eliminators.
- Shutoff (isolation) valves.
- Thermometers (if desired).

- Clean-out tees.
- Pipe strainer.

### Leaving Chilled water Piping

- Air vents (to bleed air from system).
- Water pressure gauges with shutoff valves.
- Vibration eliminators.



- Shutoff (isolation) valves.
- Thermometers.
- Clean-out tees.
- Balancing valve.

### Drains

A 1/2" drain connection is located under outlet end of evaporator waterbox for drainage during unit servicing. A shutoff valve must be installed on drain line.

### Pressure Gauges

Install field-supplied pressure components as shown in figure above. Locate pressure gauges or taps in a straight run of pipe; avoid placement near elbows, etc. Be sure to install the gauges at the same elevation on each shell if the shells have opposite-end water connections.

To read manifolded pressure gauges, open one valve and close the other (depending upon the reading desired). This eliminates errors resulting from differently calibrated gauges installed at unmatched elevations.

### Pressure Relief Valves

#### NOTICE

#### Evaporator Damage!

Failure to follow instructions below could cause damage to the evaporator.

To prevent evaporator damage, install pressure relief valves in the evaporator water system.

Install a water pressure relief valve in the evaporator inlet piping between the evaporator and the inlet shutoff valve, as shown in figure above. Water vessels with close-coupled shutoff valves have a high potential for hydrostatic pressure buildup on a water temperature increase. Refer to applicable codes for relief valve installation guidelines.

### Evaporator Flow Switch

#### NOTICE

#### Flow Switch Damage!

Incorrect voltage application could cause damage to the flow switch.

Flow switch is on a 24V circuit. Do NOT apply 120V to the flow switch.

The flow switch is factory-installed and programmed based on the operating conditions submitted with the order. The leaving evaporator temperature, fluid type and fluid concentration affect the selected flow switch. If the operating conditions on the job site change, the

flow switch may need to be replaced. Contact your local Trane Sales office for more information.

The sensor head includes 3 LEDs, two yellow and one green. Wait 15 seconds after power is applied to the sensor before evaluating LEDs for flow status. When wired correctly and flow is established, only the green LED should be lit. Following are the LED indicators:

- Green ON, both yellow OFF — Flow
- Green and outside yellow ON — No Flow
- Center yellow ON continuously — Miswire

Factory installed jumper wire W11 must be removed if using auxiliary contacts and/or additional proof of flow. See schematics in AC-SVE001\*-EN for more details.

#### NOTICE

#### Equipment Damage!

Incorrect wiring of auxiliary contacts could cause equipment damage.

See schematics for proper wiring.

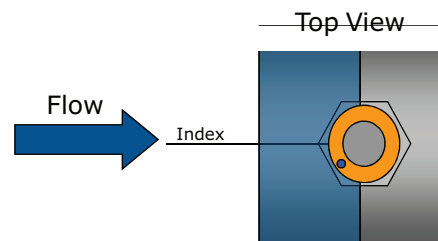
If using auxiliary flow sensing, both yellow LEDs come on initially when flow is stopped. The center yellow LED will turn off after approximately 7 seconds. The LED indicators are otherwise the same as indicated above.

### Indexing Flow Switch

To properly index the flow switch, the following requirements must be met:

- The dot must be at a position no greater than 90° off Index.
- The torque must be between 22 ft-lb minimum and 74 ft-lb maximum.
- A minimum distance of 5x pipe diameter must be maintained between flow switch and any bends, valves, changes in cross sections, etc.

**Figure 16. Proper flow switch indexing**



The flow switch must have the dot in the shaded area to the left of this line for proper indexing ( $\pm 90^\circ$  off Index).

# Evaporator Waterside Pressure Drop Curves

Figure 17. Evaporator waterside pressure drop curve – 2-pass

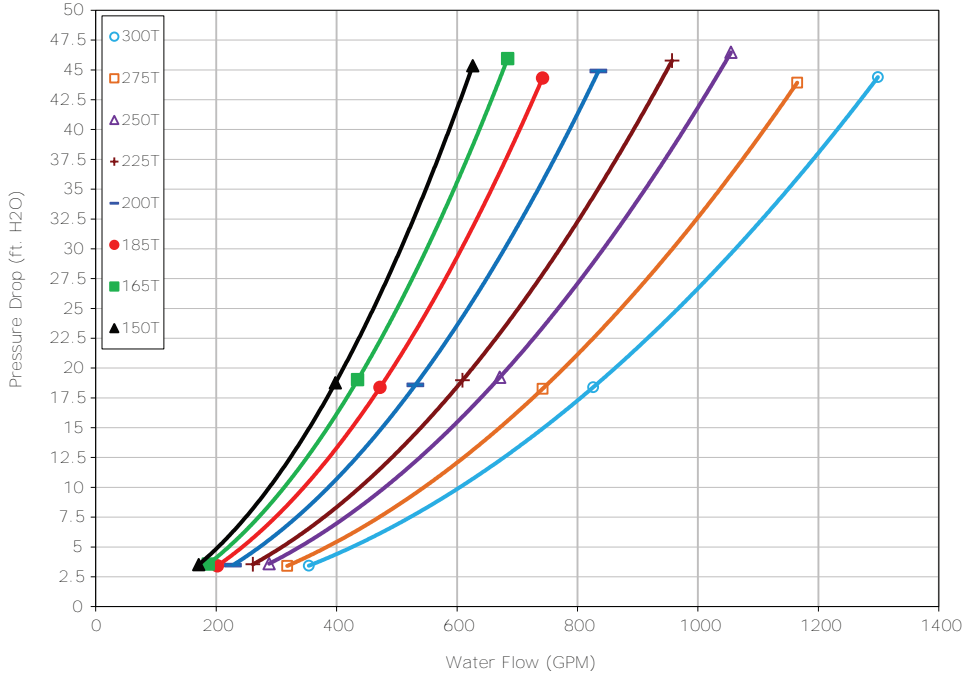
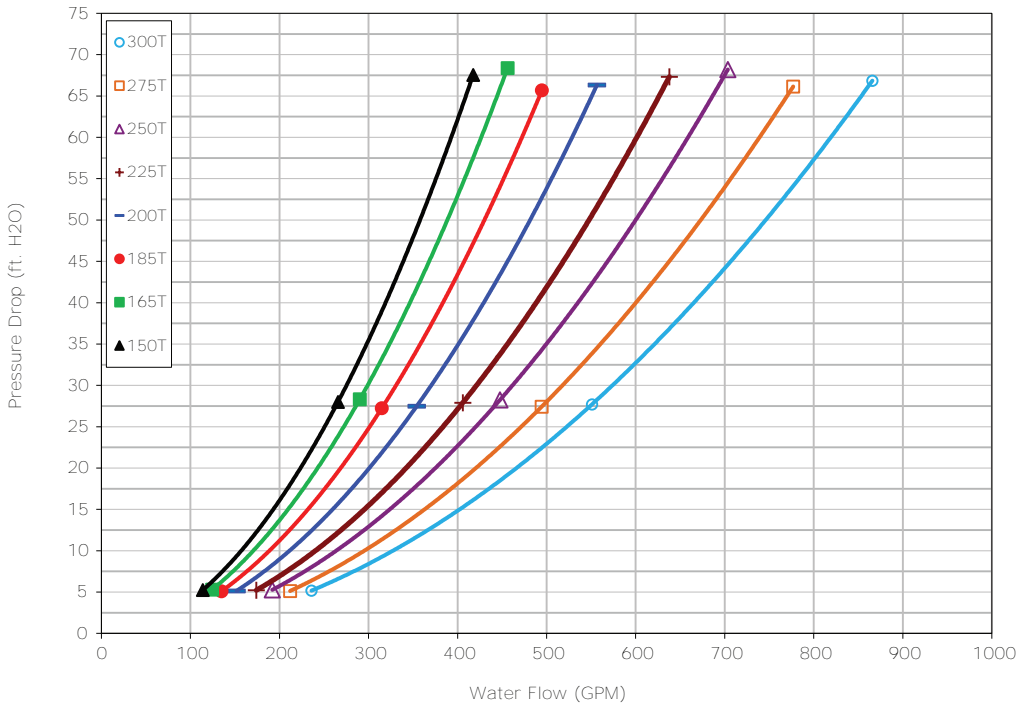


Figure 18. Evaporator waterside pressure drop curve – 3-pass



## Freeze Protection

One or more of the ambient freeze avoidance methods in the table below must be used to protect the chiller

from ambient freeze damage. See RF-PRB002\*-EN for more information.

Method	Protects to ambient temperature	Notes
Water Pump Control AND Heaters	Down to -20°F	<ul style="list-style-type: none"> <li>• <b>Heaters alone will provide low ambient protection down to -20°F (-29°C), but will NOT protect the evaporator from freezing as a result of charge migration. Therefore, it is required that water pump control be used in conjunction with heaters.</b></li> <li>• Heaters are factory-installed on the evaporator and water piping and will protect them from freezing</li> <li>• Install heat tape on all water piping, pumps, and other components that may be damaged if exposed to freezing temperatures. Heat tape must be designed for low ambient temperature applications. Heat tape selection should be based on the lowest expected ambient temperature.</li> <li>• Tracer® UC800 controller can start the pump when freezing conditions are detected. For this option the pump must to be controlled by the Stealth unit and this function must be validated.</li> <li>• Water circuit valves need to stay open at all times.</li> <li>• <b>Water pump control and heater combination will protect the evaporator down to any ambient temperature provided power is available to the pump and the controller. This option will NOT protect the evaporator in the event of a power failure to the chiller unless backup power is supplied to the necessary components.</b></li> <li>• When no chiller operation is possible and the pump is already off, UC800 pump control for freeze protection will command the pump to turn:               <ul style="list-style-type: none"> <li>– <b>ON</b> if average of the evaporator entering water temperature, the evaporator leaving water temperature, and the evaporator refrigerant pool temperature is less than Low Evaporator Refrigerant Temperature Cutout (LERTC) + 4°F for a period of time.</li> <li>– <b>OFF</b> again if the evaporator refrigerant pool temperature rises above the LERTC + 6°F for a period of time.</li> </ul> <p><b>Note:</b> Time period referenced for ON and Off conditions above is dependent on past running conditions and present temperatures measured.</p> <ul style="list-style-type: none"> <li>– <b>ON</b> if entering OR leaving water temperature &lt; LWTC for 30°F-sec (17°C-sec)</li> <li>– <b>OFF</b> again if water temperature &gt; LWTC for 30 min</li> </ul> </li> </ul>
Freeze Inhibitor	Varies. See Low Evaporator Refrigerant Cutout, Glycol Requirements.	<ul style="list-style-type: none"> <li>• Freeze protection can be accomplished by adding sufficient glycol to protect against freezing below the lowest ambient expected.</li> <li>• <b>Use of glycol type antifreeze reduces the cooling capacity of the unit and must be considered in the design of the system specifications.</b></li> </ul>
Drain Water Circuit	Below -20°F	<ul style="list-style-type: none"> <li>• Shut off the power supply to the unit and to all heaters.</li> <li>• Purge the water circuit.</li> <li>• Blow out the evaporator to ensure no liquid is left in the evaporator.</li> </ul>



**NOTICE**

**Evaporator Damage!**

Failure to follow these instructions could result in damage to the evaporator.

If insufficient concentration or no freeze inhibitor is used, the evaporator water flow must be controlled by the UC800 AND heaters must be used to avoid catastrophic damage to the evaporator due to freezing. It is the responsibility of the installing contractor and/or the customer to ensure that a pump will start when called upon by the chiller controls. Even with water pump control, a power loss of as little as 15 minutes under freezing conditions can damage the evaporator. Only the proper addition of freeze inhibitor or complete drainage of the water circuit can ensure no evaporator damage in the event of a power failure.

## Low Evaporator Refrigerant Cutout, Glycol Requirements

The table below shows the low evaporator temperature cutout for different glycol levels. Additional glycol beyond the recommendations will adversely effect unit performance. The unit efficiency will be reduced and the saturated evaporator temperature will be reduced. For some operating conditions this effect can be significant.

additional glycol is used, then use the actual percent glycol to establish the low refrigerant cutout setpoint.

**Note:** Table below is not a substitute for full unit simulation for proper prediction of unit performance for specific operating conditions. For information on specific conditions, contact Trane product support.

**Table 13. Low evaporator refrigerant temperature cutout (LERTC) and low water temperature cutout (LWTC)**

Ethylene Glycol				Propylene Glycol			
Glycol Percentage (%)	Solution Freeze Point (°F)	Minimum Recommended LERTC (°F)	Minimum Recommended LWTC (°F)	Glycol Percentage (%)	Solution Freeze Point (°F)	Minimum Recommended LERTC (°F)	Minimum Recommended LWTC (°F)
0	32	28.6	35	0	32	28.6	35
2	31	27.6	34	2	31	27.6	34
4	29.7	26.3	32.7	4	29.9	26.5	32.9
5	29	25.6	32	5	29.3	25.9	32.3
6	28.3	24.9	31.3	6	28.7	25.3	31.7
8	26.9	23.5	29.9	8	27.6	24.2	30.6
10	25.5	22.1	28.5	10	26.4	23	29.4
12	23.9	20.5	26.9	12	25.1	21.7	28.1
14	22.3	18.9	25.3	14	23.8	20.4	26.8
15	21.5	18.1	24.5	15	23.1	19.7	26.1
16	20.6	17.2	23.6	16	22.4	19	25.4
18	18.7	15.3	21.7	18	20.9	17.5	23.9
20	16.8	13.4	19.8	20	19.3	15.9	22.3
22	14.7	11.3	17.7	22	17.6	14.2	20.6
24	12.5	9.1	15.5	24	15.7	12.3	18.7
25	11.4	8	14.4	25	14.8	11.4	17.8
26	10.2	6.8	13.2	26	13.8	10.4	16.8
28	7.7	4.3	10.7	28	11.6	8.2	14.6
30	5.1	1.7	8.1	30	9.3	5.9	12.3
32	2.3	-1.1	5.3	32	6.8	3.4	9.8
34	-0.7	-4.1	5	34	4.1	0.7	7.1
35	-2.3	-5	5	35	2.7	-0.7	5.7
36	-3.9	-5	5	36	1.3	-2.1	5
38	-7.3	-5	5	38	-1.8	-5	5
40	-10.8	-5	5	40	-5.2	-5	5
42	-14.6	-5	5	42	-8.8	-5	5
44	-18.6	-5	5	44	-12.6	-5	5
45	-20.7	-5	5	45	-14.6	-5	5
46	-22.9	-5	5	46	-16.7	-5	5
48	-27.3	-5	5	48	-21.1	-5	5
50	-32.1	-5	5	50	-25.8	-5	5



# Installation Electrical

## General Recommendations

As you review this manual, keep in mind that:

- All field-installed wiring must conform to National Electric Code (NEC) guidelines, and any applicable state and local codes. Be sure to satisfy proper equipment grounding requirements per NEC.
- Compressor motor and unit electrical data (including motor kW, voltage utilization range, rated load amps) is listed on the chiller nameplate.
- All field-installed wiring must be checked for proper terminations, and for possible shorts or grounds.
- All electrical enclosures on CE marked chillers (unit model number digit 13 = C) have an environmental rating of IP53.

*Note: Always refer to wiring diagrams shipped with chiller or unit submittal for specific electrical schematic and connection information.*

### ⚠ WARNING

#### Hazardous Voltage - Pressurized Flammable Fluid!

Failure to follow all electrical safety precautions could result in death or serious injury.

Do not operate compressor without terminal box cover in place.

The motors in the compressors have strong permanent magnet motors and have the capability to generate voltage during situations when the refrigerant charge is being migrated. This potential will be present at the motor terminals and at the output of the variable speed drives in the power panel.

Before removing compressor terminal box cover for servicing, or servicing power side of control panel, CLOSE COMPRESSOR DISCHARGE SERVICE VALVE and disconnect all electric power including remote disconnects. Discharge all motor start/run capacitors. Follow lockout/tagout procedures to ensure the power cannot be inadvertently energized. Verify with an appropriate voltmeter that all capacitors have discharged.

The compressor contains hot, pressurized refrigerant. Motor terminals act as a seal against this refrigerant. Care should be taken when servicing NOT to damage or loosen motor terminals.

### ⚠ WARNING

#### Hazardous Voltage w/Capacitors!

Failure to follow these instructions could result in death or serious injury.

Disconnect all electric power, including remote disconnects and discharge all motor start/run and AFD (Adaptive Frequency™ Drive) capacitors before servicing. Follow proper lockout/tagout procedures to ensure the power cannot be inadvertently energized.

- For variable frequency drives or other energy storing components provided by Trane or others, refer to the appropriate manufacturer's literature for allowable waiting periods for discharge of capacitors. Verify with an appropriate voltmeter that all capacitors have discharged.
- DC bus capacitors retain hazardous voltages after input power has been disconnected. Follow proper lockout/tagout procedures to ensure the power cannot be inadvertently energized. After disconnecting input power, wait five (5) minutes for the DC capacitors to discharge, then check the voltage with a voltmeter. Make sure DC bus capacitors are discharged (0 VDC) before touching any internal components.

*For additional information regarding the safe discharge of capacitors, see Adaptive Frequency™ Drive Capacity Discharge section, and PROD-SVB06\*-EN.*

### ⚠ WARNING

#### Proper Field Wiring and Grounding Required!

Failure to follow code could result in death or serious injury.

All field wiring MUST be performed by qualified personnel. Improperly installed and grounded field wiring poses FIRE and ELECTROCUTION hazards. To avoid these hazards, you MUST follow requirements for field wiring installation and grounding as described in NEC and your local/state/national electrical codes.

### NOTICE

#### Use Copper Conductors Only!

Failure to use copper conductors could result in equipment damage as the equipment was not designed or qualified to accept other types of conductors.

**Important:**

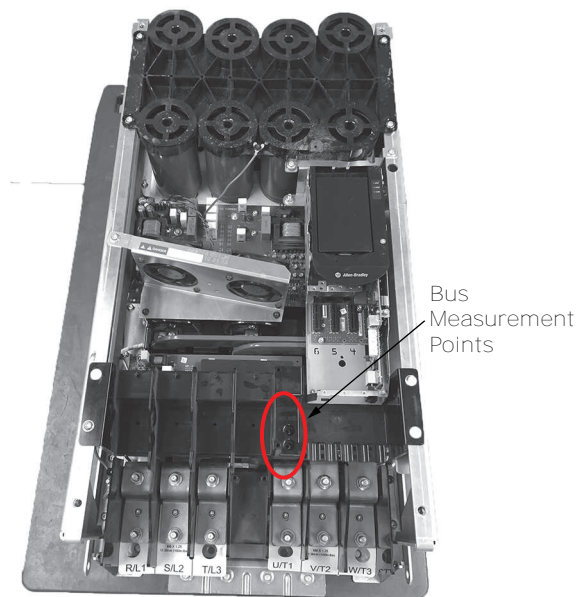
To prevent control malfunctions, do not run low voltage wiring (<30 V) in conduit with conductors carrying more than 30 volts.

**Adaptive Frequency™ Drive Capacitor Discharge**

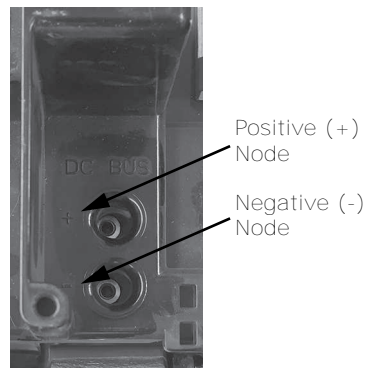
After disconnecting input power, wait five (5) minutes for the DC capacitors to discharge.

Using voltmeter, measure voltage on bus at bus access points. See figures below for location of bus access points, and details. Capacitors are fully discharged when voltage across these plus (+) and minus (-) points measures 0 VDC.

**Figure 19. AFD dc bus measurement location**



**Figure 20. Bus measurement nodes detail**



**Adaptive Frequency™ Drive Power Jumper Configuration**

The Adaptive Frequency Drives (AFDs) on both circuits contain protective MOVs and common mode capacitor circuits that are referenced to ground. To guard against drive damage and/or operation problems, these devices must be properly configured according to the table below.

For jumpers configurations, refer to [Figure 21, p. 39](#) and [Figure 22, p. 40](#). For more information, refer to AFD Service Guide (AFD-SVG002\*-EN). Allow for sufficient time after removing power to perform modifications to the AFD power jumpers. Refer to the Adaptive Frequency™ Drive Capacitor Discharge instructions .

**Table 14. AFD power jumper configurations**

Power Source Type	Jumper PE-A (MOV)	Jumper PE-B (Common Mode Caps)
Solid Ground: <ul style="list-style-type: none"> <li>Center Ground-Wye (Y)</li> </ul>	Connected <sup>(a)</sup>	Connected <sup>(a)</sup>
Non-Solid Ground: <ul style="list-style-type: none"> <li>Any Delta (Δ)</li> <li>Underground Wye (Y)</li> <li>High Impedance Ground Wye (Y)</li> </ul>	Disconnected	Disconnected

<sup>(a)</sup> Default configuration shipped from the factory. If grounding type is unknown at customer installation, leave PE-A and PE-B connected.

**Figure 21. AFD frame 6 power jumper locations**

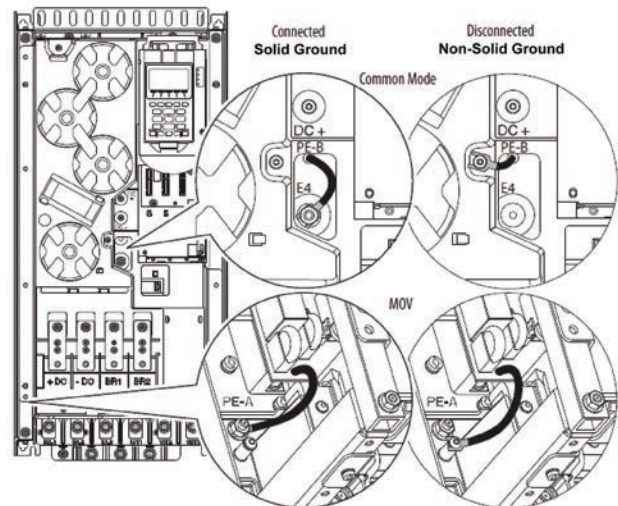
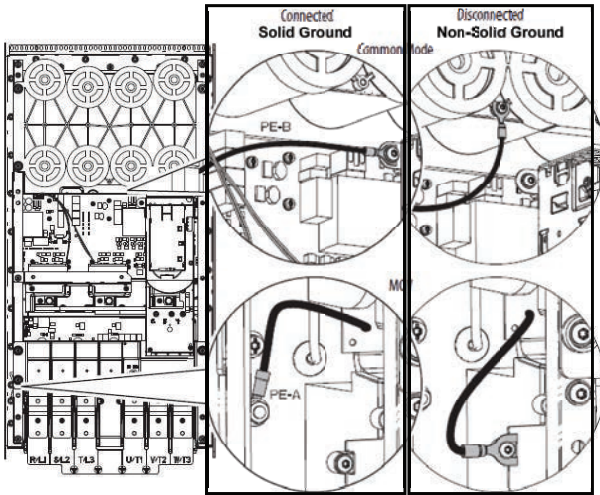


Figure 22. AFD frame 7 power jumper locations



### Units with Nitrogen Charge Option



For units with nitrogen charge option (model number digit 15 = 2), the unit must NOT have shore power, or unit power applied until the unit has been charged. Applying power will drive EXV valves closed, and will inhibit sufficient vac for unit charging.

### Installer-Supplied Components

Customer wiring interface connections are shown in the electrical schematics and connection diagrams that are shipped with the unit. The installer must provide the following components if not ordered with the unit:

- Power supply wiring (in conduit) for all field-wired connections.
- All control (interconnecting) wiring (in conduit) for field supplied devices.
- Fused-disconnect switches or circuit breakers.

### Power Supply Wiring

#### ⚠ WARNING

#### Hazardous Voltage w/Capacitors!

Failure to follow these instructions could result in death or serious injury.

Disconnect all electric power, including remote disconnects and discharge all motor start/run and AFD (Adaptive Frequency™ Drive) capacitors before servicing. Follow proper lockout/tagout procedures to ensure the power cannot be inadvertently energized.

- For variable frequency drives or other energy storing components provided by Trane or others, refer to the appropriate manufacturer’s literature for allowable waiting periods for discharge of capacitors. Verify with an appropriate voltmeter that all capacitors have discharged.
- DC bus capacitors retain hazardous voltages after input power has been disconnected. Follow proper lockout/tagout procedures to ensure the power cannot be inadvertently energized. After disconnecting input power, wait five (5) minutes for the DC capacitors to discharge, then check the voltage with a voltmeter. Make sure DC bus capacitors are discharged (0 VDC) before touching any internal components.

*For additional information regarding the safe discharge of capacitors, see Adaptive Frequency™ Drive Capacity Discharge section, and PROD-SVB06\*-EN.*

#### ⚠ WARNING

#### Proper Field Wiring and Grounding Required!

Failure to follow code could result in death or serious injury.

All field wiring **MUST** be performed by qualified personnel. Improperly installed and grounded field wiring poses **FIRE** and **ELECTROCUTION** hazards. To avoid these hazards, you **MUST** follow requirements for field wiring installation and grounding as described in NEC and your local/state/national electrical codes.

All power supply wiring must be sized and selected accordingly by the project engineer in accordance with NEC Table 310-16.

All wiring must comply with local codes and the National Electrical Code. The installing (or electrical) contractor must provide and install the system interconnecting wiring, as well as the power supply



wiring. It must be properly sized and equipped with the appropriate fused disconnect switches.

The type and installation location(s) of the fused disconnects must comply with all applicable codes.

NOTICE

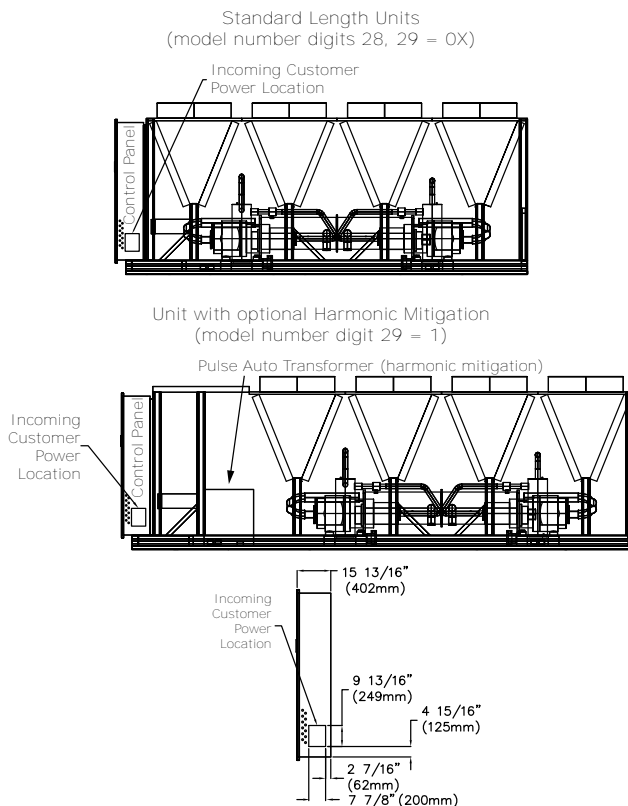
Use Copper Conductors Only!

Failure to use copper conductors could result in equipment damage as the equipment was not designed or qualified to accept other types of conductors.

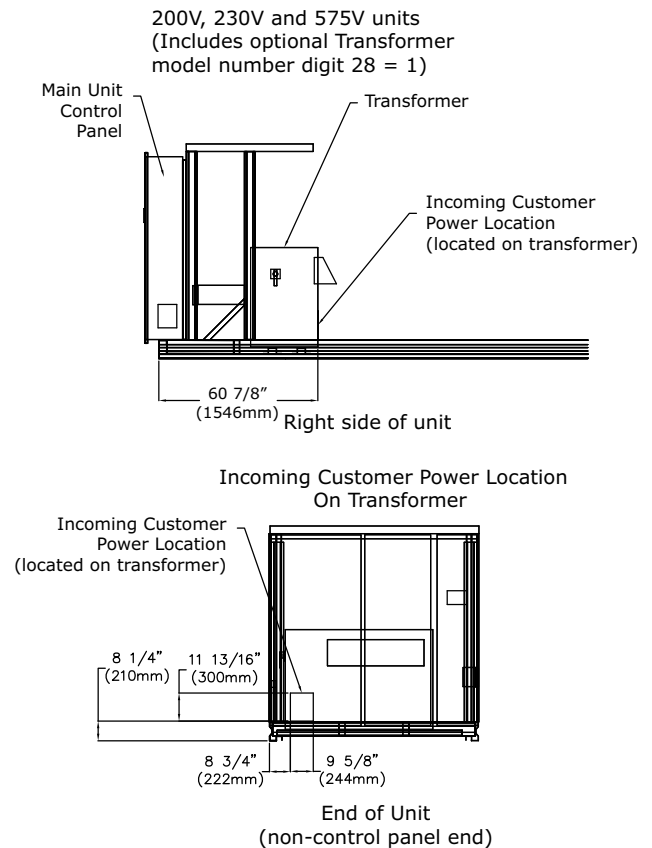
Incoming customer power location varies with unit configurations. See figures below.

- Control Panel
  - Standard length units (model number digits 28, 29 = 0X)
  - Units with optional harmonic filtration (model number digit 29 = 1)
- Transformer: 200, 230 or 575 V units with transformer (model number digit 28 = 1)

**Figure 23. Incoming customer power – control panel (right side view)**



**Figure 24. Incoming customer power – transformer**



Cut holes into the location indicated for the appropriately-sized power wiring conduits. The wiring is passed through these conduits and connected to the terminal blocks, or circuit breakers.

The high voltage field-provided connections are made through patch plate on the right side of the main control panel or on the right side of the voltage autotransformer panel.

The low voltage connections are made through knockouts provided on the left side of the control panel. Additional grounds may be required for each 115 volt power supply to the unit. Green lugs are provided for 115V customer wiring.

## Control Power Supply

The unit is equipped with a control power transformer. It is not necessary to provide additional control power voltage to the unit. No other loads should be connected to the control power transformer.

All units are factory-connected for appropriate labeled voltages.

## Service Power Connection

The service power connection is a touch safe procedure to allow for binding the control system and LLIDs. Service power connection allows for a NEMA 5-



## Installation Electrical

15 style extension cord to power on Class 2 devices (i.e. UC800, LLIDs, EXVs, and TD7 display) with an external power source, without the need of line voltage applied to the unit. This connection is to be made at 1XJ50. The extension cord power source is required to have upstream current protection rated at no more than 10A. The required voltage for the service power connection is 115V at 60Hz and 110V at 50Hz.

### Heater Power Supply

The evaporator shell is insulated from ambient air and protected from freezing temperatures by thermostatically-controlled immersion heaters. See table below for evaporator heater summary. Whenever the water temperature drops to approximately 37°F (2.8°C), the thermostat energizes the heaters. The heaters will provide protection from ambient temperatures down to -20°F (-29°C).

#### NOTICE

#### Evaporator Damage!

Failure to follow instructions below could result in evaporator damage.

A qualified technician must confirm operation of the thermostat. Control panel main processor does not verify thermostat operation.

**Table 15. Evaporator heater summary**

Unit Size (tons)	Waterboxes	
	Supply	Return
2-pass Evaporator		
150 to 165	400W	400W
180 to 200	400W (Qty 2)	400W
225 to 300	600W	600W
3-pass Evaporator		
All sizes	400W (Qty 2)	400W

### Chilled Water Pump Control

#### NOTICE

#### Evaporator Damage!

If the microprocessor calls for a pump to start and water does not flow, the evaporator may be damaged catastrophically.

It is the responsibility of the installing contractor and/or the customer to ensure that a pump will always be running when called upon by the chiller controls.

An evaporator water pump output relay's normally-open contact closes to start the evaporator water pump when the chiller is given a signal to go into the Auto mode of operation from any source. The contact is

opened to turn off the pump in the event of most machine level diagnostics to prevent the build up of pump heat.

The relay output is required to operate the Evaporator Water Pump (EWP) contactor. The relay's contacts are compatible with 115/240 VAC control circuits. See Programmable Relays section for rating details. Normally, the EWP relay follows the AUTO mode of the chiller. Whenever the chiller has no diagnostics and is in the AUTO mode, regardless of where the auto command is coming from, the relay is energized and the normally-open contact is closed. When the chiller exits the AUTO mode, the relay's normally-open contact is timed to open in an adjustable (using Tracer® TU service tool) 0 to 30 minutes. The non-AUTO modes in which the pump is stopped, include Reset, Stop, External Stop, Remote Display Stop, Stopped by Tracer, Start Inhibited by Low Ambient Temp, and Ice Building complete.

**Table 16. Pump relay operation**

Chiller Mode	Relay Operation
Auto	Instant Close
Ice Building	Instant Close
Tracer Override	Close
Stop	Timed Open
Ice Complete	Instant Open
Diagnostics	Instant Operation <sup>(a)</sup>
Chiller Shutdown Diagnostics (except freeze protection)	Instant Open
Freeze Protection related chiller shutdown diagnostics	Initially: Remain Closed Then: Delayed/Dependent Open
Chiller Off Cycle Freeze Diagnostics	Instant Close – Dependent Open

<sup>(a)</sup> Operation can be instant open or instant close, depending on diagnostic.

When going from Stop to Auto, the EWP relay is energized immediately. If evaporator water flow is not established in 20 minutes (for normal transition) or 4 minutes, 15 seconds (for pump commanded ON due to an override safety), the UC800 de-energizes the EWP relay and generates a non-latching diagnostic. If flow returns (e.g. someone else is controlling the pump), the diagnostic is cleared, the EWP is re-energized, and normal control resumed.

If evaporator water flow is lost once it had been established, the EWP relay remains energized and a non-latching diagnostic is generated. If flow returns, the diagnostic is cleared and the chiller returns to normal operation.

In general, when there is either a non-latching or latching diagnostic, the EWP relay is turned off as though there was a zero time delay. Exceptions

whereby the relay continues to be energized occur with:

- **Low Chilled Water Temperature diagnostic** (non-latching unless also accompanied by an Evap Leaving Water Temperature Sensor Diagnostic)

OR

- **Interrupt Failure —AFDxA diagnostic** where x is either 1 or 2 to indicate which drive is affected), in which a compressor continues to draw current even after commanded to have shutdown.

OR

- **Loss of Evaporator Water Flow diagnostic** (non-latching) and the unit is in the AUTO mode, after initially having proven evaporator water flow.

## Programmable Relays

A programmable relay concept provides for enunciation or hardwired interlocking of certain events or states of the chiller, selected from a list of likely needs, while only using four physical output relays, as shown in the field wiring diagram. The four relays are provided (generally with a Quad Relay Output LLID) as part of the Programmable Relay Option. The relay's contacts are isolated Form C (SPDT), suitable for use with 120 VAC circuits drawing up to 2.8 amps inductive, 7.2 amps resistive, or 1/3 HP and for 240 VAC circuits drawing up to 0.5 amp resistive.

The list of events/states that can be assigned to the programmable relays can be found in the following table. The relay will be energized when the event/state occurs.

**Table 17. Alarm and status relay output configurations**

Description	
Alarm (Latching)	This output is true whenever there is any active latching shutdown diagnostic that targets the Unit, Circuit, or any of the Compressors on a circuit.
Alarm (Non-Latching)	This output is true whenever there is any active non-latching shutdown diagnostic that targets the Unit, Circuit, or any of the Compressors on a circuit.
Alarm	This output is true whenever there is any active latching or non-latching shutdown diagnostic that targets the Unit, Circuit, or any of the Compressors on a circuit.
Alarm Ckt 1	This output is true whenever there is any active latching or non-latching shutdown diagnostic that targets Circuit 1, or any of the Compressors on Circuit 1.
Alarm Ckt 2	This output is true whenever there is any active latching or non-latching shutdown diagnostic that targets Circuit 2, or any of the Compressors on Circuit 2.

**Table 17. Alarm and status relay output configurations (continued)**

Description	
Unit Limit Mode	This output is true whenever a circuit on the unit has been running in one of the limit modes continuously for the Limit Relay debounce time. A given limit or overlapping of different limits must be in effect continuously for the debounce time prior to the output becoming true. It will become false if no limits are present for the debounce time.
Compressor Running	The output is true whenever any compressor is running.
Circuit 1 Running	The output is true whenever any compressor of Circuit 1 is running.
Circuit 2 Running	The output is true whenever any compressor of Circuit 2 is running.
Maximum Capacity	The output is true whenever the unit has reached maximum capacity continuously for the Max Capacity Relay debounce time. The output is false when the unit is not at maximum capacity continuously for the filter debounce time.
Head Pressure Relief Request	This relay output is energized anytime the chiller or a single circuit on the chiller is running in one of the following modes; Ice Making Mode, or Condenser Pressure Limit continuously for the duration specified by the Chiller Head Relief Relay Filter Time. The Chiller Head Relief Relay Filter Time is a service setpoint. The relay output is de-energized anytime the chiller exits all above modes continuously for the duration specified by the same Chiller Head Relief Relay Filter Time

## Relay Assignments Using Tracer TU

Tracer@TU Service Tool is used to install the Programmable Relay Option package and assign any of the above list of events or status to each of the four relays provided with the option. (See Tracer@ TU section of Controls chapter for more information on this service tool.) The relays to be programmed are referred to by the relay's terminal numbers on the LLID board 1K13.

The default assignments for the four available relays of the Programmable Relay option are show in the table below.

**Table 18. Default assignments**

Relay	Assignment
Relay 1 Terminals J2-1,2,3:	Unit Limit Mode
Relay 2 Terminals J2-4,5,6:	Maximum Capacity
Relay 3 Terminals J2 - 7,8,9:	Compressor Running
Relay 4 Terminals J2 -10,11,12:	Alarm



## Installation Electrical

If any of the Alarm/Status relays are used, provide electrical power, 115 VAC with fused-disconnect to the panel and wire through the appropriate relays (terminals on 1K13). Provide wiring (switched hot, neutral, and ground connections) to the remote annunciation devices. Do not use power from the chiller's control panel transformer to power these remote devices. See the field wiring diagrams which are shipped with the unit.

### Low Voltage Wiring

The remote devices described below require low voltage wiring. All wiring between these remote input devices and the control panel must be made with shielded, twisted pair conductors. Ground the shielding only at the panel.

**Important:** *The remote devices described below require low voltage wiring. All wiring to and from these remote input devices to the Control Panel must be made with shielded, twisted pair conductors. Be sure to ground the shielding only at the panel.*

### Emergency Stop

UC800 provides auxiliary control for a customer specified/installed latching trip out. When this customer-furnished remote contact 5K35 is provided, the chiller will run normally when the contact is closed. When the contact opens, the unit will trip on a latching diagnostic. This latched condition requires either a manual reset at the front of the control panel or a power cycle of the UC800 to clear.

Connect low voltage leads to terminal strip locations on 1K2. Refer to the field diagrams that are shipped with the unit.

Silver or gold-plated contacts are recommended. These customer-furnished contacts must be compatible with 24 VDC, 12 mA resistive load.

### External Auto/Stop

If the unit requires the external Auto/Stop function, the installer must provide leads from the remote contacts 5K34 to the proper terminals of the LLID 1K2 on the control panel.

The chiller will run normally when the contacts are closed. When either contact opens, the compressor(s), if operating, will go to the RUN:UNLOAD operating mode and cycle off. Unit operation will be inhibited. Closure of the contacts will permit the unit to return to normal operation.

Field-supplied contacts for all low voltage connections must be compatible with dry circuit 24 VDC for a 12 mA resistive load. Refer to the field diagrams that are shipped with the unit.

### External Circuit Lockout – Circuit #1 and #2

UC800 provides for an auxiliary input of a customer specified or installed contact closure, for individual inhibition of the operation of either or both circuits. If the contact (5K32 for Ckt1, or 5K33 for Ckt2) is closed, the respective refrigerant circuit will not operate.

Upon contact opening, the respective refrigerant circuit will run normally. This feature is used to restrict total chiller operation, e.g. during emergency generator operations.

Connections to 1K3 inputs are shown in the field diagrams that are shipped with the unit.

These customer-supplied contact closures must be compatible with 24 VDC, 12 mA resistive load. Silver or gold plated contacts are recommended

### Ice Building Option

UC800 provides auxiliary control for a customer specified/installed contact closure for ice building if so configured and enabled. This output is known as the Ice Building Status Relay. The normally open contact will be closed when ice building is in progress and open when ice building has been normally terminated either through Ice Termination setpoint being reached or removal of the Ice Building command. This output is for use with the ice storage system equipment or controls (provided by others) to signal the system changes required as the chiller mode changes from "ice building" to "ice complete". When contact 5K36 is provided, the chiller will run normally when the contact is open.

UC800 will accept either an isolated contact closure (External Ice Building command) or a Remote Communicated input (Tracer) to initiate and command the Ice Building mode.

UC800 also provides a "Front Panel Ice Termination Setpoint", settable through Tracer® TU, and adjustable from 20 to 31°F (-6.7 to -0.5°C) in at least 1°F (1°C) increments.

**Note:** *When in the ice building mode, and the evaporator entering water temperature drops below the ice termination setpoint, the chiller terminates the ice building mode and changes to the ice building complete mode.*

## NOTICE

### Equipment Damage!

Failure to follow instructions could result in damage to system components.

Freeze inhibitor must be adequate for the leaving water temperature.

Tracer® TU must also be used to enable or disable Ice Machine Control. This setting does not prevent the Tracer from commanding Ice Building mode.

Upon contact closure, the UC800 will initiate an ice building mode, in which the unit runs fully loaded at all times. Ice building shall be terminated either by opening the contact or based on the entering evaporator water temperature. UC800 will not permit the ice building mode to be reentered until the unit has been switched out of ice building mode (open 5K36 contacts) and then switched back into ice building mode (close 5K36 contacts.)

In ice building, all limits (freeze avoidance, evaporator, condenser, current) will be ignored. All safeties will be enforced.

If, while in ice building mode, the unit gets down to the freeze stat setting (water or refrigerant), the unit will shut down on a manually resettable diagnostic, just as in normal operation.

Connect leads from 5K36 to the proper terminals of 1K8. Refer to the field diagrams which are shipped with the unit.

Silver or gold-plated contacts are recommended. These customer furnished contacts must be compatible with 24 VDC, 12 mA resistive load.

### External Chilled Water Setpoint (ECWS) Option

The UC800 provides inputs that accept either 4-20 mA or 2-10 VDC signals to set the external chilled water setpoint (ECWS). This is not a reset function. The input defines the setpoint. This input is primarily used with generic building automation systems (BAS). The chilled water setpoint set via the Tracer AdaptiView™ TD7 or through digital communication with Tracer (Comm3). The arbitration of the various chilled water setpoint sources is described in the flow charts at the end of the section.

The chilled water setpoint may be changed from a remote location by sending either a 2-10 VDC or 4-20 mA signal to the 1K14, terminals 5 and 6 LLID. 2-10 VDC and 4-20 mA each correspond to a 10 to 65°F (-12 to 18° C) external chilled water setpoint.

The following equations apply:

Voltage Signal	
As generated from external source	$VDC = 0.1455 * (ECWS) + 0.5454$
As processed by UC800	$ECWS = 6.875 * (VDC) - 3.75$
Current Signal	
As generated from external source	$mA = 0.2909 (ECWS) + 1.0909$
As processed by UC800	$ECWS = 3.4375 (mA) - 3.75$

If the ECWS input develops an open or short, the LLID will report either a very high or very low value back to the main processor. This will generate an informational

diagnostic and the unit will default to using the front Panel (TD7) Chilled Water Setpoint.

Tracer® TU Service Tool is used to set the input signal type from the factory default of 2-10 VDC to that of 4-20 mA. Tracer® TU is also used to install or remove the External Chilled Water Setpoint option as well as a means to enable and disable ECWS.

### External Demand Limit Setpoint (EDLS) Option

Similar to the above, the UC800 also provides for an optional External Demand Limit Setpoint that will accept either a 210 VDC (default) or a 420 mA signal. The Demand Limit Setting can also be set via the Tracer AdaptiView™ TD7 or through digital communication with Tracer (Comm 3). The arbitration of the various sources of demand limit is described in the flow charts at the end of this section. The External Demand Limit Setpoint may be changed from a remote location by hooking up the analog input signal to the 1K14 LLID terminals 2 and 3. Refer to the following paragraph on Analog Input Signal Wiring Details. The following equations apply for EDLS:

Voltage Signal	
As generated from external source	$VDC = 0.133 * (\%) - 6.0$
As processed by UC800	$\% = 7.5 * (VDC) + 45.0$
Current Signal	
As generated from external source	$mA = 0.266 * (\%) - 12.0$
As processed by UC800	$\% = 3.75 * (mA) + 45.0$

If the EDLS input develops an open or short, the LLID will report either a very high or very low value back to the man processor. This will generate an informational diagnostic and the unit will default to using the Front Panel (Tracer AdaptiView™ TD7) Demand Limit Setpoint.

The Tracer® TU Service Tool must be used to set the input signal type from the factory default of 2-10 VDC to that of 420 mA current. Tracer TU must also be used to install or remove the External Demand Limit Setpoint Option for field installation, or can be used to enable or disable the feature (if installed).

### EDLS and ECWS Analog Input Signal Wiring

Both the ECWS and EDLS can be connected and setup as either a 2–10 VDC (factory default), 4-20 mA, or resistance input (also a form of 4–20mA) as indicated below. Depending on the type to be used, the Tracer® TU Service Tool must be used to configure the LLID and the main processor for the proper input type that is being used. This is accomplished by a setting change

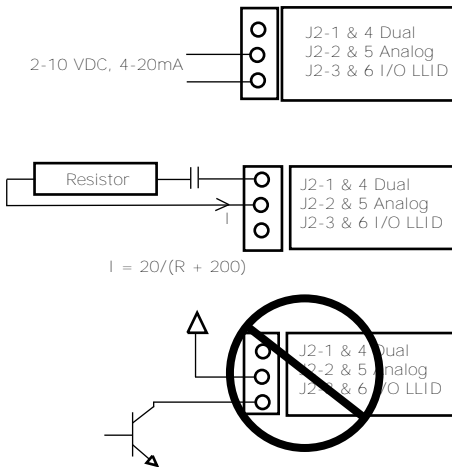
## Installation Electrical

on the Custom Tab of the Configuration View within Tracer® TU.

**Important:** For proper unit operation, BOTH the EDLS and ECWS settings MUST be the same (2-10 VDC or 4-20mA), even if only one input is to be used.

The J23 and J26 terminal is chassis grounded and terminal J2 1 and J24 can be used to source 12 VDC. The ECLS uses terminals J22 and J23. ECWS uses terminals J25 and J26. Both inputs are only compatible with highside current sources.

**Figure 25. Wiring examples for EDLS and ECWS**



### Chilled Water Reset (CWR)

UC800 resets the chilled water temperature set point based on either return water temperature, or outdoor air temperature. Return Reset is standard, Outdoor Reset is optional.

The following shall be selectable:

- One of three Reset types: None, Return Water Temperature Reset, Outdoor Air Temperature

Reset Type	Range Reset Ratio	Start Reset	Max Reset	Increment	Factory Default
Return	10 to 120%	4 to 30°F (2.2 to 16.7 °C)	0 to 20°F (0.0 to 11.1°C)	1%	50%
Outdoor	80 to -80%	50 to 130°F (10 to 54.4°C)	0 to 20°F (0.0 to 11.1°C)	1%	10%

In addition to Return and Outdoor Reset, the MP provides a menu item for the operator to select a Constant Return Reset. Constant Return Reset will reset the leaving water temperature set point so as to provide a constant entering water temperature. The Constant Return Reset equation is the same as the Return Reset equation except on selection of Constant Return Reset, the MP will automatically set Ratio, Start Reset, and Maximum Reset to the following:

- RATIO = 100%
- START RESET = Design Delta Temp.

Reset, or Constant Return Water Temperature Reset.

- Reset Ratio setpoints: For outdoor air temperature reset there shall be both positive and negative reset ratios.
- Start Reset Setpoints.
- Maximum Reset setpoints.

The equations for each type of reset are as follows:

#### Return

$$CWS' = CWS + RATIO (START RESET - (TWE - TWL))$$

and  $CWS' > \text{or} = CWS$

and  $CWS' - CWS < \text{or} = \text{Maximum Reset}$

#### Outdoor

$$CWS' = CWS + RATIO * (START RESET - TOD)$$

and  $CWS' > \text{or} = CWS$

and  $CWS' - CWS < \text{or} = \text{Maximum Reset}$

#### where

- CWS' is the new chilled water set point or the "reset CWS"
- CWS is the active chilled water set point before any reset has occurred, e.g. normally Front Panel, Tracer, or ECWS
- RESET RATIO is a user adjustable gain
- START RESET is a user adjustable reference
- TOD is the outdoor temperature
- TWE is entering evap. water temperature
- TWL is leaving evap. water temperature
- MAXIMUM RESET is a user adjustable limit providing the maximum amount of reset. For all types of reset,  $CWS' - CWS < \text{or} = \text{Maximum Reset}$ .

- MAXIMUM RESET = Design Delta Temp.

The equation for Constant Return is then as follows:

$$CWS' = CWS + 100\% (\text{Design Delta Temp.} - (TWE - TWL))$$

and  $CWS' > \text{or} = CWS$

When any type of CWR is enabled, the MP will step the Active CWS toward the desired CWS' (based on the above equations and setup parameters) at a rate of 1 degree F every 5 minutes until the Active CWS equals

the desired CWS'. This applies when the chiller is running.

When the chiller is not running, CWS is reset immediately (within one minute) for Return Reset and at a rate of 1 degree F every 5 minutes for Outdoor Reset. The chiller will start at the Differential to Start value above a fully reset CWS or CWS' for both Return and Outdoor Reset.

## Transformer Power Rating

See table below for power rating of optional transformer (unit model number digit 28 = 1).

Unit Size	Power Rating
150 to 200 tons	340 kVA
225 to 300 tons	470 kVA

## Communications Interface

### LonTalk Interface (LCI-C)

UC800 provides an optional LonTalk® Communication Interface (LCI-C) between the chiller and a building automation system (BAS). An LCI-C LLID shall be used

to provide "gateway" functionality between a LonTalk® compatible device and the chiller. The inputs/outputs include both mandatory and optional network variables as established by the LONMARK® Functional Chiller Profile 8040.

**Note:** For more information see ACC-SVN100\*-EN.

### BACnet Interface (BCI-C)

Optional BACnet® Communication Interface for Chillers (BCI-C) is comprised of a Tracer® UC800 controller with interface software. It is a non-programmable communications module that allows units to communicate on a BACnet® communications network.

**Note:** For more information, see BAS-SVP01\*-EN.

### Modbus Remote Terminal Unit Interface

Modicon Communication Bus (Modbus™) enables the chiller controller to communicate as a slave device on a Modbus™ network. Chiller setpoints, operating modes, alarms and status can be monitored and controlled by a Modbus™ master device.

**Note:** For more information, see BAS-SVP01\*-EN.



# Operating Principles

This section contains an overview of the operation and maintenance of units equipped with UC800 control systems. It describes the overall operating principles of the Ascend™ ACRA design.

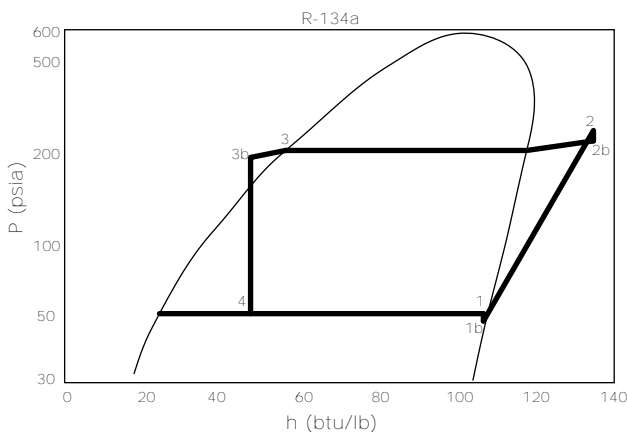
## Refrigeration Circuits

Each unit has two refrigerant circuits, with one rotary screw compressor per circuit. Each refrigerant circuit includes a compressor suction and discharge service valve, liquid line shutoff valve, removable core filter, liquid line sight glass with moisture indicator, charging port and an electronic expansion valve. Fully modulating compressors and electronic expansion valves provide variable capacity modulation over the entire operating range. Lower condensing temperatures and higher suction temperatures along with more efficient compressors and fans result in the premium efficiency level.

## Refrigeration Cycle

The refrigeration cycle of the chiller is represented in the pressure enthalpy diagram shown in figure below. Key state points are indicated on the figure. The cycle for the full load AHRI design point is represented in the plot.

**Figure 26. Pressure-enthalpy (P-h) diagram**



The chiller uses a shell and tube evaporator design with refrigerant evaporating on the shell side and water flowing inside tubes having enhanced surfaces (states 4 to 1). The suction lines are designed to minimize pressure drop.(states 1 to 1b). The compressor is a twin-rotor helical rotary compressor designed similarly to the compressors offered in other Trane Screw Compressor Based Chillers (states 1b to 2). The discharge lines include a highly efficient oil separation system that removes 99.8% of the oil from the refrigerant stream going to the heat exchangers (states 2 to 2b). De-superheating, condensing and sub-cooling

is accomplished in a fin and tube air cooled heat exchanger where refrigerant is condensed in the tube (states 2b to 3b). Refrigerant flow through the system is balanced by an electronic expansion valve (states 3b to 4).

## Refrigerant R-134a

The Ascend™ ACRA chiller uses environmentally friendly R-134a. Trane believes responsible refrigerant practices are important to the environment, our customers, and the air conditioning industry. All technicians who handle refrigerants must be certified. The Federal Clean Air Act (Section 608) sets forth the requirements for handling, reclaiming, recovering and recycling of certain refrigerants and the equipment that is used in these service procedures. In addition, some states or municipalities may have additional requirements that must also be adhered to for responsible management of refrigerants. Know the applicable laws and follow them.

Refrigerant R-134a is a medium pressure refrigerant. It may not be used in any condition that would cause the chiller to operate in a vacuum without a purge system. Ascend™ ACRA is not equipped with a purge system. Therefore, the chiller may not be operated in a condition that would result in a saturated condition in the chiller of -15°F (-26°C) or lower.

Refrigerant R-134a requires the use of specific POE oils as designated on the unit nameplate.

**Important:** Use only R-134a and Trane Oil 00311 (bulk)/00315 (1gal)/00317 (5gal) .

## Compressor and Oil System

The rotary screw compressor is variable Vi (variable pressure ratio) semi-hermetic, direct drive with capacity control via a variable speed drive, rolling element bearings, differential refrigerant pressure oil pump and oil heater. To maximize efficiency, the variable Vi compressor is controlled to one of two possible states depending on the chiller system operating point and to provide ease of starting. The motor is a suction gas cooled, hermetically sealed, permanent magnet motor. An oil separator is provided separately from the compressor. Oil filtration is provided internal to the compressor. Check valves in the compressor discharge and lube oil system are also provided.

## Condenser and Fans

Air-cooled condenser coils have aluminum fins mechanically bonded to internally finned seamless aluminum tubing. The tubing is a long life alloy designed to deliver corrosion performance that meets or exceeds microchannel coils. The condenser coil has



an integral subcooling circuit. Condensers are factory proof tested and leak tested with helium in a mass spectrometer chamber. All tube connections are mechanical except the brazed copper to aluminum inlet and outlet connections. Condenser fans are direct-drive vertical discharge. The condenser fan motors are permanent magnet motors with an integrated drive to provide variable speed fan control for all fans and are designed with permanently lubricated ball bearings, internal temperature and current overload protection, and fault feedback as a standard product offering. The fan impeller is a nine bladed-shrouded fan made from heavy-duty molded plastic. Standard units will start and operate between 32 to 105°F (0 to 40°C) ambient.

The UC800 controls calculate optimum fan speed for maximum efficiency based on compressor load and outdoor air, resulting in high IPLV values

## Evaporator

The evaporator is a tube-in-shell heat exchanger design constructed from carbon steel shells and tubesheets. Internally and externally finned seamless copper tubes are mechanically expanded into the tube sheets. The evaporator is designed, tested and marked in accordance with the ASME Boiler and Pressure Vessel Code for a refrigerant side working pressure of 200

psig. The evaporator is designed for a water side working pressure of 150 psig. Standard water connections are grooved for Victaulic style pipe couplings, with flange style connections optionally available. Waterboxes are available in 2 and 3 pass configurations and include a vent, a drain and fittings for temperature control sensors. Evaporators are insulated with 3/4 inch closed cell insulation. Evaporator water heaters with thermostat are provided to help protect the evaporator from freezing at ambient temperatures down to -20°F (-29°C). A factory installed flow switch is installed on the supply water box in the evaporator inlet connection.

## Drive Cooling System

Each refrigeration circuit has a compressor drive cooling circuit. Each drive cooling circuit is a closed system, and includes a wet rotor pump that circulates a secondary heat transfer fluid between the adaptive frequency drive components, the heat sinks of the adaptive frequency drive, and a brazed plate heat exchanger. The pump is fed from a thermal expansion tank with a vented-pressure cap, which is also used as the circuit pressure relief. The circuit also includes a particulate strainer and a drain valve for servicing.



# Controls

## Overview

Ascend™ model ACR units utilize the following control/interface components:

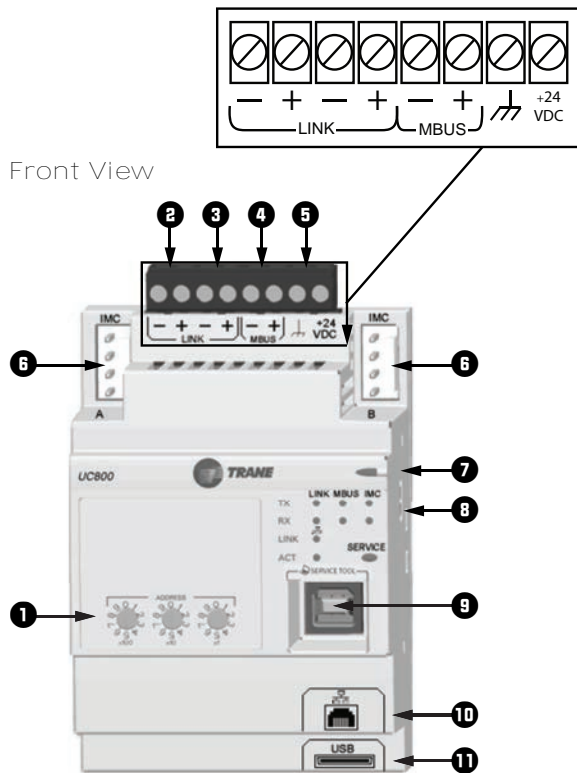
- Tracer® UC800 Controller
- Tracer AdaptiView™ TD7 Operator Interface

## UC800 Specifications

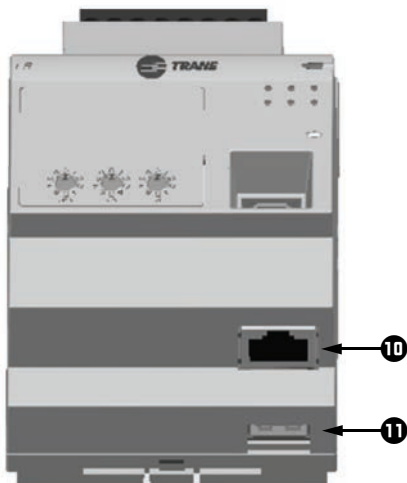
### Wiring and Port Descriptions

The following figure illustrates the UC800 controller ports, LEDs, rotary switches, and wiring terminals. The numbered list following the figure corresponds to the numbered callouts in the illustration.

**Figure 27. UC800 wiring locations and connection ports**



Bottom View



1. Rotary Switches for setting BACnet® MAC address or MODBUS® ID.
2. LINK for BACnet® MS/TP, or MODBUS® Slave (two terminals, ±). Field wired if used.
3. LINK for BACnet® MS/TP, or MODBUS® Slave (two terminals, ±). Field wired if used.
4. Machine bus for existing machine LLIDs (IPC3 Tracer bus). *IPC3 Bus: used for LonTalk® using LCI-C.*

5. Power (210 mA at 24 Vdc) and ground terminations (same bus as Item 4). Factory wired.
6. Internal Modbus connection to AFDs (not a customer connection)
7. Marquee LED power and UC800 Status indicator (refer to the table in “LED Description and Operation,” p. 51).
8. Status LEDs for the BAS link, MBus link, and IMC link.
9. USB device Type B connection for the service tool (Tracer® TU).
10. The Ethernet connection can *only* be used with the Tracer® AdaptiView™ display.
11. USB Host (not used).

### Communication Interfaces

There are four connections on the UC800 that support the communication interfaces listed. Refer to the figure in “Wiring and Port Descriptions,” p. 50 for the locations of each of these ports.

- BACnet® MS/TP
- MODBUS® Slave
- LonTalk® using LCI-C (from the IPC3 bus)

### Rotary Switches

There are three rotary switches on the front of the UC800 controller. Use these switches to define a three-digit address when the UC800 is installed in a BACnet® or MODBUS® system (e.g., 107, 127, etc.).

**Note:** Valid addresses are 001 to 127 for BACnet® and 001 to 247 for MODBUS®.

### LED Description and Operation

There are ten LEDs on the front of the UC800. The following figure shows the locations of each LED and the following table describes their behavior in specific instances.

Figure 28. LED locations

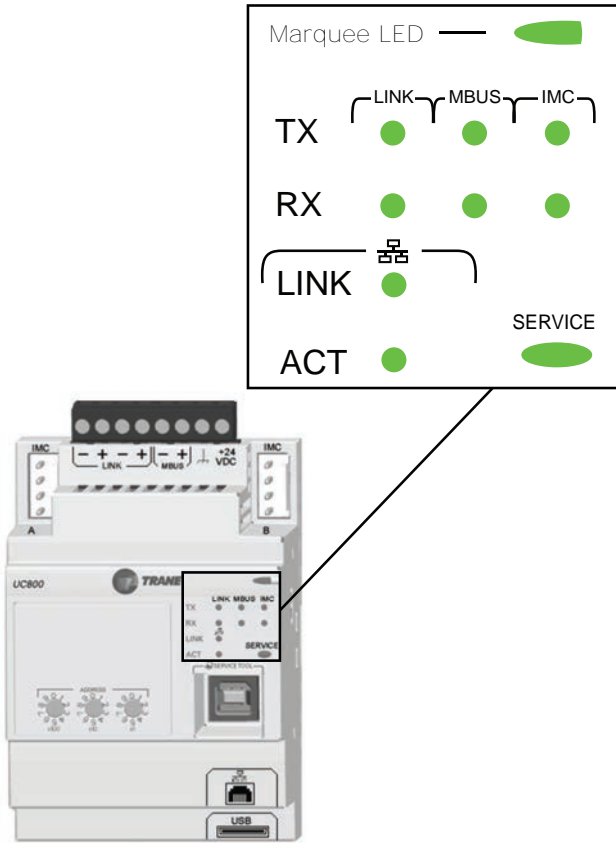


Table 19. LED behavior

LED	UC800 Status
Marquee LED	<b>Powered.</b> If the Marquee LED is green solid, the UC800 is powered and no problems exist.
	<b>Low power or malfunction.</b> If the Marquee LED is red solid, the UC800 is powered but there are problems present.
	<b>Alarm.</b> The Marquee LED blinks red when an alarm exists.
LINK, MBUS, IMC	The <b>TX</b> LED blinks green at the data transfer rate when the UC800 transfers data to other devices on the link.
	The <b>RX</b> LED blinks yellow at the data transfer rate when the UC800 receives data from other devices on the link.
Ethernet Link	The <b>LINK</b> LED is solid green if the Ethernet link is connected and communicating.
	The <b>ACT</b> LED blinks yellow at the data transfer rate when data flow is active on the link.
Service	The <b>Service</b> LED is solid green when pressed. For qualified service technicians only. Do NOT use.

**Important:** Maintain at least 6 in. (16 cm) between low-voltage (less than 30V) and high voltage circuits.

# Tracer AdaptiView TD7 Display

## Operator Interface

Information is tailored to operators, service technicians, and owners. When operating a chiller, specific information is needed on a day-to-day basis—

setpoints, limits, diagnostic information, and reports. This information is provided through the Tracer® AdaptiView™ TD7 display. Logically organized groups of information— chiller modes of operation, active diagnostics, settings and reports put information conveniently at your fingertips.

Figure 29. TD7 screens



Operator Display Boot Screen

Display Loading Data

Home Screen, Auto Mode

## Home Screen

The home screen (see following figure) provides the most frequently needed chiller status information on “touch targets” (the entire white rectangular areas) for each chiller component. Touching any touch target displays a screen containing more chiller status information related to each component.

Figure 30. Home screen

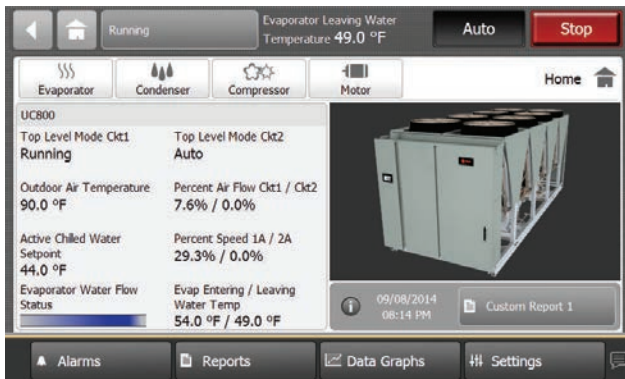


Table 20. Home screen items

Description	Resolution	Units
Top Level Mode Ckt1		
Top Level Mode Ckt2		
Outdoor Air Temperature	XX.X	°F / °C
Percent Air Flow Ckt1/Ckt 2	X.X/X.X	%
Active Chiller Water Setpoint	XX.X	°F / °C

Table 20. Home screen items (continued)

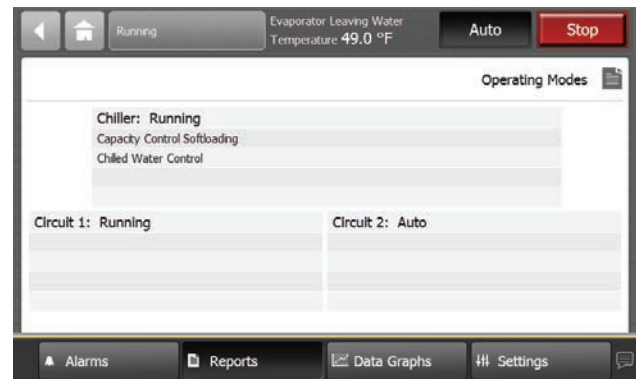
Description	Resolution	Units
Percent Speed 1A/2A	22.2	%
Evaporator Water flow Status	Flow/No Flow	
Evap Entering/Leaving Water Temp	XX.X/XX.X	°F / °C

## Viewing Chiller Operating Modes

On the Reports screen, click Chiller Operating Modes to view the current operating status of the chiller in terms of the top-level operating mode and submodes.

**Note:** Chiller Operating Modes screen can also be accessed from the chiller status button in the upper left corner of the screen.

Figure 31. Chiller operating modes



**Table 21. Operating modes – chiller**

<b>Chiller Modes</b>	<b>Description</b>
MP Resetting	
Stopped	The chiller is not running either circuit, and cannot run without intervention, for instance to place chiller into the "Auto Mode" or to clear a manual reset chiller level diagnostic.
Local Stop	Chiller is stopped by the AdaptiView Stop button command- cannot be remotely overridden.
Immediate Stop	Chiller is stopped by the AdaptiView Immediate Stop (by pressing the Stop then Immediate Stop buttons in succession) – previous shutdown was manually commanded to shutdown immediately.
No Circuits Available	The entire chiller is stopped by circuit diagnostics or lockouts.
Diagnostic Shutdown - Manual Reset	The chiller is stopped by a Chiller Level diagnostic that requires manual intervention to reset.
Power Up Delay Inhibit: min:sec	On Power up, the chiller will wait for the Power Up Delay Timer to expire.
Run Inhibit	The chiller is currently being inhibited from starting (and running), but may be allowed to start if the chiller inhibit or the Chiller or Circuit level (effecting both circuits) diagnostic conditions are manually or automatically cleared.
No Circuits Available	The entire chiller is stopped by circuit diagnostics or lockouts that may automatically clear.
Software Service Lock	TU service tool invoked chiller lockout to prevent operation of the chiller during certain procedures, such as configuration or binding
Ice Building Is Complete	The chiller is inhibited from running as the Ice Building process has been normally terminated on the evaporator entering temperature. The chiller will not start unless the ice building command (hardwired input or Building Automation System command) is removed or cycled.
Ice to Normal Transition	The chiller is inhibited from running for a brief period of time if it is commanded from active ice building mode into normal cooling mode via the ice building hardwired input or Tracer. This allows time for the external system load to "switchover" from an ice bank to the chilled water loop, and provides for a controlled pull down of the loop's warmer temperature. This mode is not seen if the ice making is automatically terminated on return brine temperature per the mode below.
Start(ing is) Inhibited by BAS (Building Automation System)*	Chiller is stopped by Tracer or other BAS system per BAS communicated commands or (depending on configuration and settings) by lack of communication with the BAS system.
Start(ing is) Inhibited by External Source	The chiller is inhibited from starting or running by the "external stop" hardwired input.
Diagnostic Shutdown - Auto Reset	The entire chiller is stopped by a diagnostic that may automatically clear. The chiller is stopped by a Chiller Level diagnostic that may be reset automatically depending on conditions and the specific diagnostic's reset criteria.
Start(ing is) Inhibited by Low Ambient Temperature	The chiller is inhibited based on the outdoor air temperature.
Power Up Delay Inhibit: min:sec	On Power up, the chiller will wait for the Power Up Delay Timer to expire.
Maximum Capacity	Because the chiller is unable to run, when the chiller is in a Top Level Run Inhibit mode, the maximum capacity submode simply echoes that there is no additional capacity available at this time, unless the cause of the inhibit is removed.
Auto	The chiller is not currently running but can be expected to start at any moment given that the proper conditions and interlocks are satisfied.
Waiting For Evap(orator) Water Flow	The unit will wait up to 20 minutes in this mode for water flow to be established per the flow switch hardwired input.
Waiting For A Need To Cool	The chiller will wait indefinitely in this mode, for a leaving water temperature higher than the Chilled Water Setpoint plus some control dead-band.
Waiting to Start	The chiller is not currently running and there is a call for cooling but the lead circuit start is delayed by certain interlocks or proofs. Further information is provided by the sub-mode:

**Table 21. Operating modes – chiller (continued)**

Chiller Modes	Description
Cold Ambient Start Inhibit – Waiting for Warmer Water	During startups with Outdoor Ambient temperatures less than 18°F, it may be necessary to require warmer entering water to avoid a freeze danger at startup. The occurrence of this mode suggests that startup is being inhibited pending warmer water temperatures than otherwise would be required by the Differential to Start and Active Chilled Water Temperature settings.
Running	At least one circuit on the chiller is currently running.
Chilled Water Control	Chiller is running to provide a chilled water temperature per the active chilled water setpoint (may be as arbitrated from various sources). (For cooling only units, this mode may be suppressed.)
Maximum Capacity	The chiller is operating at its maximum capacity.
Capacity Control Softloading	The control is limiting the chiller loading due to capacity based softloading setpoints.
Demand Limit Softloading	The chiller is running, and loading of individual compressors may be limited by a gradual filter of the chiller’s softloading Demand Limit setpoint. The starting Demandlimit and the settling time of this filter is user adjustable as part of the Demand control softload feature. The mode will be displayed as long as the Demand Control Softloading limit is ramping or “settling”.
Shutting Down	The chiller is still running but shutdown is imminent. The chiller is going through a compressor run-unload or extended operational pumpdown of the lag circuit/compressor (or all circuits simultaneously)
Evaporator Water Pump Off Delay: MIN:SEC	The Evaporator water pump is continuing to run past the shutdown of the compressors, executing the pump off delay timer.
Various	These submodes may be displayed in most of the top level chiller modes.
Manual Evap(orator) (Water) Pump Override	The Evaporator water pump relay is on due to a manual command.
Diagnostic Evap (Water) Pump Override	The Evaporator water pump relay is on due to a diagnostic.
Waiting for BAS Communications	The chiller has not detected communication with the BAS. This mode is only supported by LonTalk systems. Depending on configurations and Setpoint source setting, lack of communication may cause the chiller to shut down and or become inhibited from starting, but if so, the “Starting is Inhibited by BAS” mode will also occur.
Manual Compressor Control Signal	Chiller capacity control is being controlled by AdaptiView or TU.
Noise Reduction	The Chiller’s Noise Reduction Mode has been activated. The condenser fans may be limited to a lower speed than design, to reduce fan noise.
Chilled Water Control	
These modes are mutually exclusive and they indicate that the chiller is controlling to the active hot water setpoint, the active chilled water setpoint, or the active ice termination setpoint respectively.	
Ice Building	

**Note:** Mode strings may or may not include the characters in parentheses.

**Table 22. Operating modes – circuit**

Circuit Modes	Description
Stopped	The circuit is not running, and cannot run without intervention.
Diagnostic Shutdown – Manual Reset	The circuit has been shutdown on a latching diagnostic.
Front Panel Circuit Lockout	The circuit is manually locked out by the circuit lockout setting – the nonvolatile lockout setting is accessible through either the AdaptiView or TU.
External Circuit Lockout	The respective circuit is locked out by the external circuit lockout binary input.
Service Pumpdown	The circuit is currently performing a service pumpdown.

**Table 22. Operating modes – circuit (continued)**

<b>Circuit Modes</b>	<b>Description</b>
Run Inhibit	The given circuit is currently being inhibited from starting (and running), but may be allowed to start if the inhibiting or diagnostic condition is cleared.
Diagnostic Shutdown – Auto Reset	The circuit has been shutdown on a diagnostic that may clear automatically.
Low Oil Flow Cool Down Time mn:sec	See oil flow protection spec
Restart Inhibit min:sec	The compressor (and therefore, its circuit) is currently unable to start due to its restart inhibit timer. A given compressor is not allowed to start until 5 minutes (adj) has expired since its last start, once a number of "free starts" have been used up.
Low Evap Rfgt Temp (Inh-bit)*	A start of the circuit had been requested, but the circuit is inhibited from starting due to a high value of the Low Evaporator Refrigerant Temperature Integral from the last cycle. If the alternate circuit is available, it will be substituted. Delaying a start in this situation, avoids a latching diagnostic of the running Low Evaporator Refrigerant Temperature Cutout protection.
Auto	The circuit is not currently running but can be expected to start at any moment given that the proper conditions are satisfied.
Calibrating EXV	This submode is displayed when the EXV is performing a calibration. A calibration is only performed when the chiller is not running and never more frequently than once every 24 hours.
Waiting to Start	The circuit is going through the necessary steps to allow the lead circuit to start.
Start Inhibited Waiting For Oil	The compressor (and thus its circuit) will wait up to 2 minutes in this mode for oil level to appear in the oil tank.
Running	The compressor on the given circuit is currently running.
Establishing Min(imum) Cap(acity) – Low Diff (erential) Pressure	The circuit is experiencing low system differential pressure and its compressor is being force loaded, irrespective of the Chilled Water Temperature Control, to develop pressure sooner.
Establishing Min Cap – High Disch Temp	The circuit is running with high discharge temperatures and its compressor is being forced loaded to its step load point, without regard to the leaving water temperature control, to prevent tripping on high compressor discharge temperature.
Establishing Min Cap – Low Vi Min Speed	The compressor is being forced to a higher speed than desired for capacity control, in order to maintain compressor bearing reliability while in the low Vi state.
Maximum Capacity	The individual circuit is running at the maximum speed possible – no more capacity is available from this circuit.
Running - Limit	The circuit, and compressor are currently running, but the operation of the chiller/ compressor is being actively limited by the controls. Further information is provided by the sub-mode.* See the section below regarding criteria for annunciation of limit modes
(High) Condenser Pressure Limit	The circuit is experiencing condenser pressures at or near the condenser limit setting. Compressors on the circuit will be unloaded to prevent exceeding the limits.*
(Low) Evaporator (Rfgt) Temperature Limit	The circuit is experiencing saturated evaporator temperatures at or near the Low Refrigerant Temperature Cutout setting. Compressors on the circuit will be unloaded to prevent tripping.*
EXV Capacity Limit	The EXV is near or beyond 95% wide open, or is predicted to get to that position if the compressor was to run at full speed, and the capacity of the circuit (compressor speed) is being held or reduced in order to prevent loss of oil return or insufficient drive cooling.
Noise Reduction (Fan Limit)	The condenser fans of the circuit are potentially being limited by an active chiller-level Noise Reduction Request to a lower maximum possible speed in order to limit the noise levels.
Flooded or Hot Start Capacity Limit	This mode will occur at circuit start, if the evaporator is sensed to be full of liquid, or if the evaporator entering water temperature is greater than 65°F while the outdoor air temperature is greater than 70°F. This transient starting mode implies the compressor has begun operation at a speed below the configured "normal" minimum compressor speed, in order to avoid carryover.
Demand Limit	The compressor is running and is being capacity limited by a high demand power draw in excess of the compressor's share of the active Demand Limit Setting for the entire chiller.
Shutting Down	The circuit is preparing to de-energize the compressor.



**Table 22. Operating modes – circuit (continued)**

Circuit Modes	Description
Operational Pumpdown	The circuit is in the process shutting down by performing an operational pumpdown just prior to stopping the circuit's compressor. The EXV is commanded closed. Pumpdown will terminate when the evaporator pressure reaches the termination pressure (below a specific criteria) or after a specific time has expired.

**Note:** Mode strings may or may not include the characters in parentheses.

## Alarms

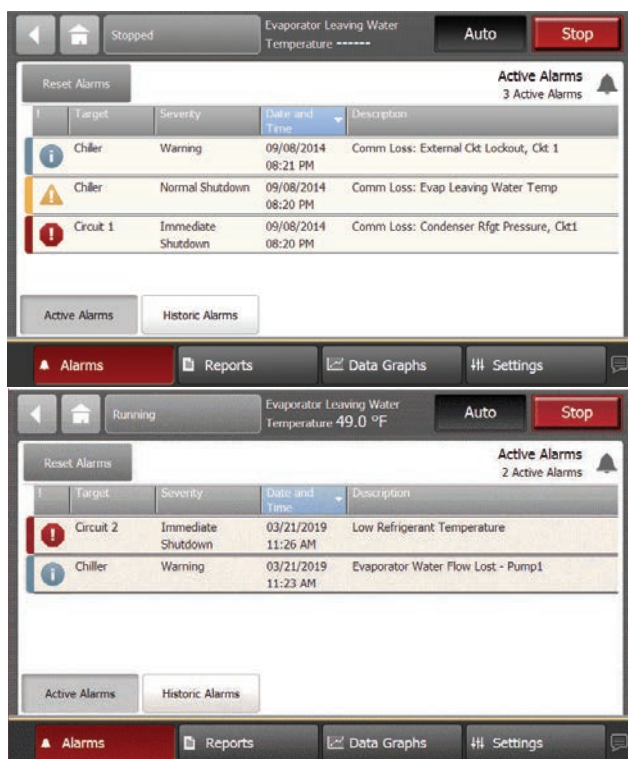
Alarms can be viewed and reset using the TD7 display. Alarms are communicated to the display immediately upon detection.

### Viewing the Alarms Screen

Click the Alarms button in the main menu area to view the Alarm screen.

The Alarm screen will display a table of active alarms, listed chronologically, with the most recent first. See the following figure for an example of default view. The alarm list can be sorted by other columns.

**Figure 32. Alarm screen**



## Reports

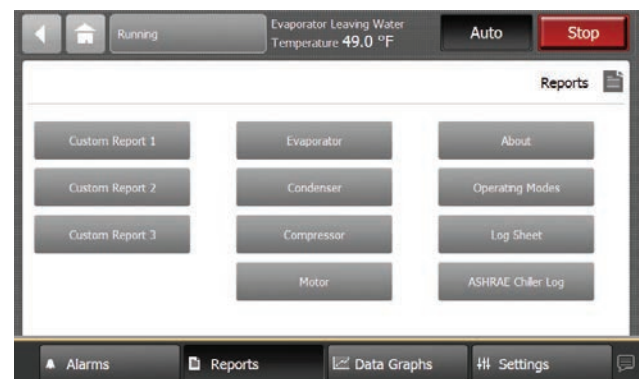
The TD7 provides the a variety of reports and allows the creation and editing of custom reports. All reports contain live data that refreshes every 2–5 seconds.

## Viewing the Reports Screen

Click the Reports button in the main menu area to view the Reports screen. The Reports screen contains the following buttons to access the selected report:

- Custom Report1
- Custom Report2
- Custom Report3
- Evaporator
- Condenser
- Compressor
- Motor
- About
- Operating Modes
- Log Sheet
- ASHRAE Chiller Log

**Figure 33. Report screen**



## Editing a Custom Report

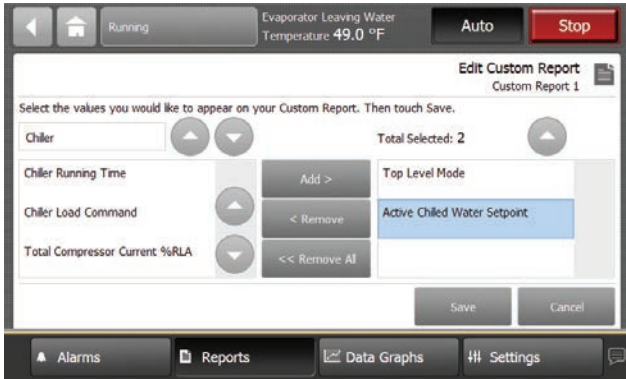
A custom report can be edited by adding, removing, or re-ordering data. Click **Edit** to access the Edit Custom Report screen.:

- **Add Items:** Select item to be added. Selected item will change to blue. Use arrows to scroll to additional items, and select all items to be added. Click **Add** to move the selected item to the box on the right side of the screen.
- **Remove Items:** Select item to be removed. Selected item will change to blue. Use arrows to scroll to additional items, and select all items to be removed. Click **Remove** to move the selected item to the box on the left side of the screen.

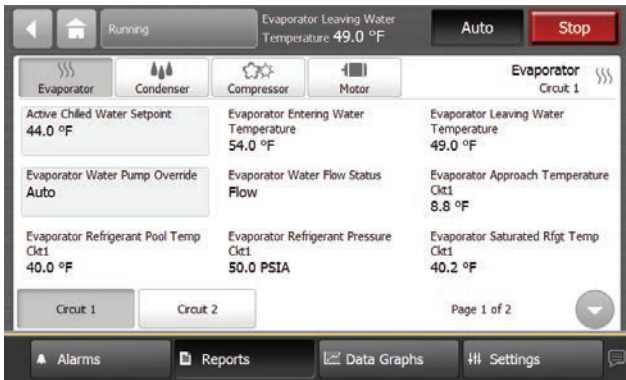
- **Re-order Items:** Select item to be moved. Selected item will change to blue. Use arrows to change the order of the item.

Touch **Save** to save and view the edited custom report.

**Figure 34. Edit custom report screen**



**Figure 35. Report – evaporator screen**



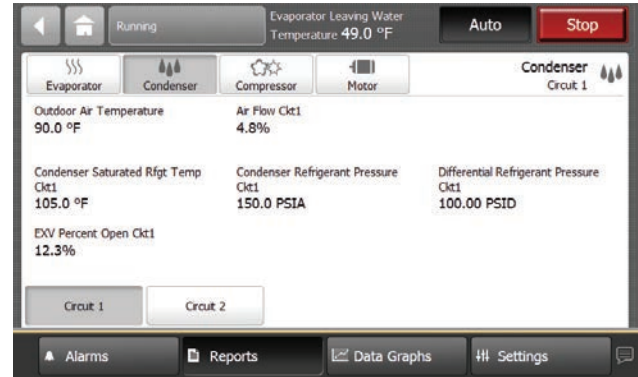
**Table 23. Report – evaporator screen items**

Description	Resolution	Units
Active Chilled Water Setpoint	X.X	°F / °C
Evaporator Entering Water Temperature	X.X	°F / °C
Evaporator Leaving Water Temperature	X.X	°F / °C
Evaporator Water Flow Status	Flow, No Flow	Text
Evaporator Water Pump Override	Auto, On	Text
Evaporator Approach Temperature	X.X	°F / °C
EXV Position Percent	X.X	%
Evaporator Refrigerant Pressure	XXX.X	PSIA/kPa

**Table 23. Report – evaporator screen items (continued)**

Description	Resolution	Units
Evaporator Saturated Rfght Temp	X.X	°F / °C
Evaporator Refrigerant Liquid Level	X.XX	in/mm

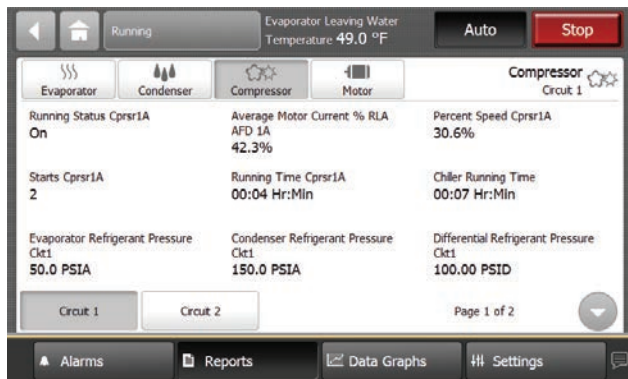
**Figure 36. Report – condenser screen**



**Table 24. Report – condenser screen items**

Description	Resolution	Units
Condenser Entering Water Temperature	X.X	F / C
Condenser Leaving Water Temperature	X.X	F / C
Condenser Water Flow Status	Flow, No Flow	Text
Condenser Water Pump Override	Auto, On	Text
Condenser Approach Temperature	X.X	F / C
EXV Position Percent	X.X	%
Condenser Refrigerant Pressure	XXX.X	PSIA/kPa
Condenser Saturated Rfght Temp	X.X	F / C
Differential Refrigerant Pressure	XXX.X	PSIA/kPa
Outdoor Air Temperature	X.X	F / C

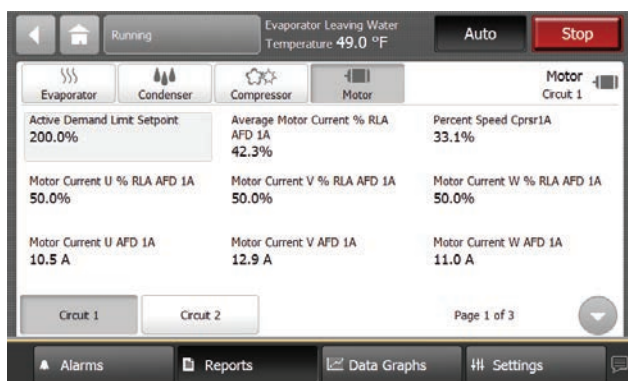
**Figure 37. Report — compressor screen**



**Table 25. Report — compressor screen items**

Description	Resolution	Units
Compressor Running Status	On,Off	Text
Average Motor Current % RLA	XX.X%	%RLA
Compressor Starts	XX	Text
Compressor Running Time	XX:XX	Hr:Min
Oil Loss Level Sensor	Wet, Dry	Text
Discharge Temperature	X.X	°F / °C
Discharge Temperature	X.X	°F / °C
Compressor Oil Pressure	XXX.X	PSIA/kPaA
Evaporator Refrigerant Pressure	XXX.X	PSIA/kPaA
Condenser Refrigerant Pressure	XXX.X	PSIA/kPaA
Differential Refrigerant Pressure	XXX.X	PSIA/kPaA
Frequency Command	XX.X	Hz

**Figure 38. Report — motor screen**



**Table 26. Report — motor screen items**

Description	Resolution	Units
Active Current Limit Setpoint	X.X	%RLA
Average Motor Current % RLA	X.X	%RLA
Starter Motor Current L1 %RLA	X.X	%RLA
Starter Motor Current L2 %RLA	X.X	%RLA
Starter Motor Current L3 %RLA	X.X	%RLA
Starter Motor Current L1	X.X	A
Starter Motor Current L1	X.X	A
Starter Motor Current L1	X.X	A
Starter Input Voltage AB	XXX.X	V
Starter Input Voltage BC	XXX.X	V
Starter Input Voltage CA	XXX.X	V
Average Motor Current	X.X	A
Average Phase Voltage	XXX.X	V
Frequency Command	XX.X	Hz

### Equipment Settings

You can use the TD7 display to monitor and change a variety of equipment settings.

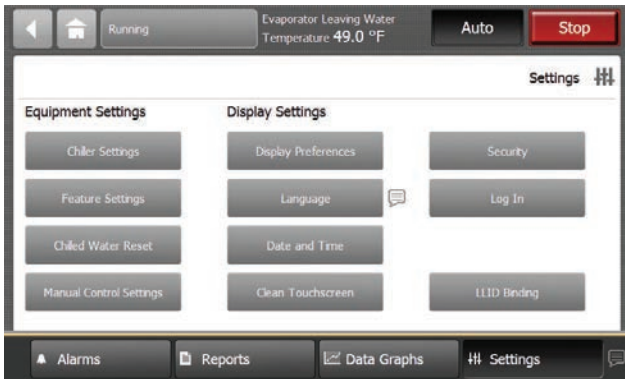
### Accessing Equipment Settings

Equipment Settings are found on the left column of the Settings screen as shown in figure below. Included are the following:

- Chiller Settings
- Feature Settings
- Chilled Water Reset
- Manual Control Settings

Each selection will provide access to the detailed settings submenus.

**Figure 39. Settings screen**

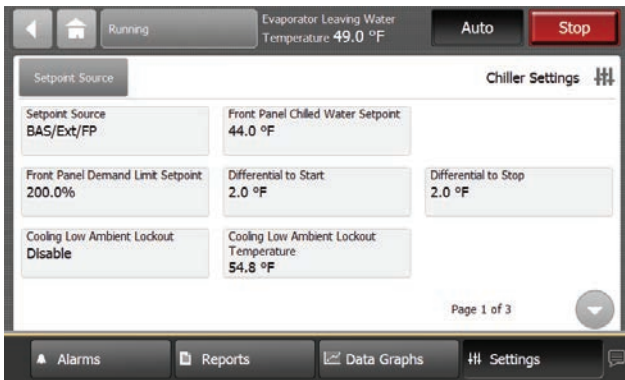


**Viewing and Changing Equipment Settings**

Each button in the Equipment Settings column on the Settings screen takes you to a submenu which displays the name of a setting and its current value. See figure below. Click any button to select and change the value.

*Note: A page number appears in the lower right corner of the screen. If a screen contains more than one page, up/down arrows also appear for viewing the other pages, as in figure below.*

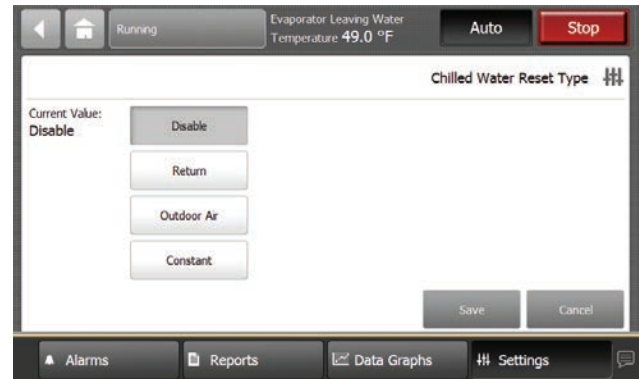
**Figure 40. Equipment settings screen — chiller settings**



To change an equipment setting, click desired setting from Equipment Settings column on the Settings screen. Click the setting to be changed. The screen to input new data will be one of two types:

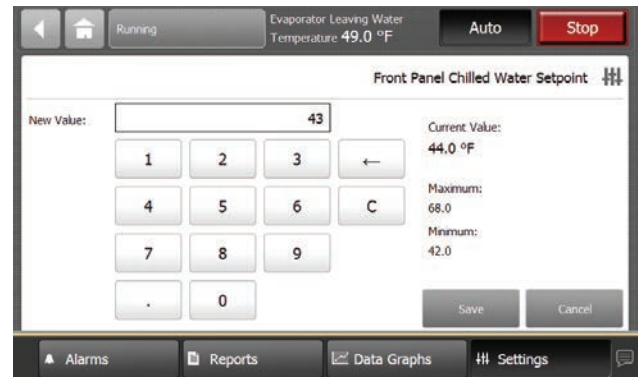
- **Button selections:** When clicked to select, the button becomes shaded, and a Save button appears at the bottom of the screen, as show below.

**Figure 41. Chilled water reset screen**



- **Numeric keypad screen:** For settings screen with numeric keypads (see example in figure below), enter the current value using the keypad. The new value will appear above the keypad. Keypad features:
  - When a new number is entered, the value in the New Value field is deleted and replaced with the new entry.
  - The backspace (arrow) key deletes the characters previously entered.
  - If the keypad is used to enter a setpoint that is out of range, an error dialog will appear when the **Save** button is selected.
  - Keypads that allow negative numbers have positive and negative number (+/-) keys.

**Figure 42. Changed chilled water setpoint screen**



Click **Save** to complete the change. The current value is updated in the upper left side of the screen, demonstrating that the change has been communicated to the Tracer® UC800 controller.

**Table 27. Settings screen items**

Description	Resolution	Units
Chiller Settings		
Active Chilled Water Setpoint	± XXX.X	°F / °C

**Table 27. Settings screen items (continued)**

Description	Resolution	Units
Active Current Limit Setpoint	XXX %	%RLA
Active Panel Base Load Cmd	On/Auto	Text
Active Base Loading Setpoint	XXX	%
Active Base Loading Command	On/Auto	Text
Differential to Start	XXX.X	°F / °C
Differential to Stop	XXX.X	°F / °C
Setpoint Source		
(BAS/Ext/FP, Ext/Front Panel, Front Panel)	BAS/Ext/FP	Text
Evaporator Water Pump Off Delay	XX	Min
Condenser Pump Prestart Time	XX	Min
High Evap Water Temp Cutout	XXX.X	°F / °C
Evaporator Leaving Water Temp Cutout	XX.X	°F / °C
Low Refrigerant Temperature Cutout	XX.X	°F / °C
Current Limit Softload Start Point	XXX.X	%
Current Limit Control Softload Time	XXXX	Sec
Capacity Control Softload Time	XXXX	Sec
Local Atmospheric Pressure	XXX.X	psi/kPa
Power Up Start Delay	XXX	Min
<b>Feature Settings</b>		
External Chilled/Hot Water Setpoint (Enable/Disable)		Text
External Current Limit Setpoint (Enable/Disable)		Text
LCI-C Diagnostic Encoding (Enable/Disable)		Text
Chilled Water Reset (Constant, Outdoor, Return, Disable)	Disable	Text
Return Reset Ratio	XXX	%
Return Start Reset	XXX.X	°F / °C
Return Maximum Reset	XXX.X	°F / °C
Outdoor Reset Ratio	XXX	%

**Table 27. Settings screen items (continued)**

Description	Resolution	Units
Outdoor Start Reset	XXX.X	°F / °C
Outdoor Maximum Reset	XXX.X	°F / °C
<b>Mode Overrides</b>		
Evap Water Pump (Auto, On)	Auto	Text
Cond Water Pump (Auto, On)	Auto	Text

## Display Settings

Display settings can be customized. The display also includes a function to clean the touch screen.

### Viewing the Settings Screen

Display Settings are found on the right column of the Settings screen which includes the following:

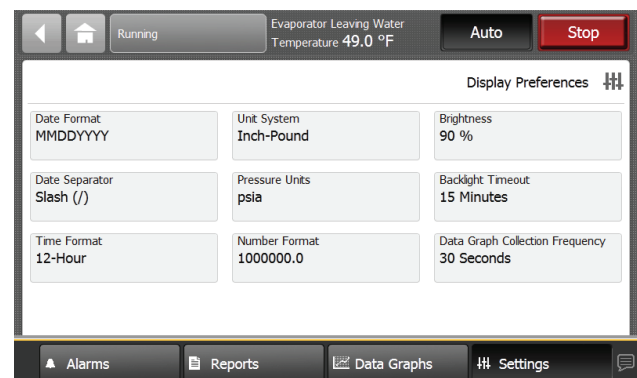
- Display Preferences
- Language
- Date and Time
- Clean Display

### Viewing and Changing Display Preferences

On the Settings screen, click **Display Preferences** which includes the following:

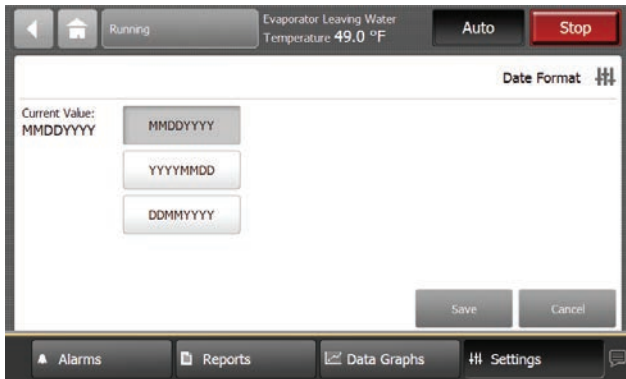
- Date Format
- Date Separator
- Time Format
- Unit System
- Pressure Units
- Number Format

**Figure 43. Display preference screen**



Each of the buttons shows the current value for each selection. Click any of these buttons to change. Select the option to be changed, which will be shaded.. Example in figure below shows a selection of MMDDYYYY for the date format.

**Figure 44. Date format preference selection**



Click **Save** to confirm your selection and return to Display Preferences screen.

Following are the preference options available:

- **Date Format**
  - MMDDYYYY (default)
  - YYYYMMDD
  - DDMMYYYY
- **Date Separator**
  - None
  - Slash (default)
  - Hyphen
- **Time Format**
  - 12 hour (default)
  - 24 hour
- **Units System**
  - SI
  - I-P (default)
- **Pressure Units**
  - kPaA (default if “SI” is chosen for display units)
  - kPaG
  - PSIA (default if “I-P” is chosen for display units)
  - PSIG
- **Number Format**
  - 1000000.0
  - 1000000,0

### Viewing and Changing Language

On the Settings screen, click **Language**. The current setting will be shaded, as shown in figure below. To change the language, click the preferred language to select. Click **Save** to confirm selection.

**Figure 45. Language settings**



### Viewing and Changing Date and Time

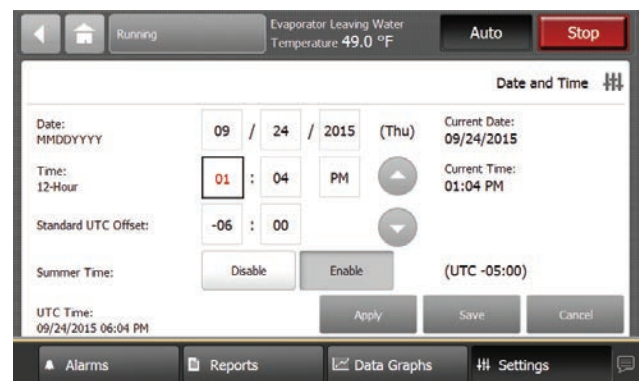
On the Settings screen, click **Date and Time**. The current date and time appear at the bottom of the screen. The following options are available to change on the main screen:

- Month
- Day
- Year
- Hour
- Minute
- AM/PM

To change any settings, click the corresponding button to highlight, then use up/down arrow keys to set desired value. Repeat for any other items to be changed. When complete, click **Save** to confirm selection and return to Settings screen.

**Note:** To edit field using keypad entry, click the highlighted button a second time to access the keypad.

**Figure 46. Date and time settings screen**

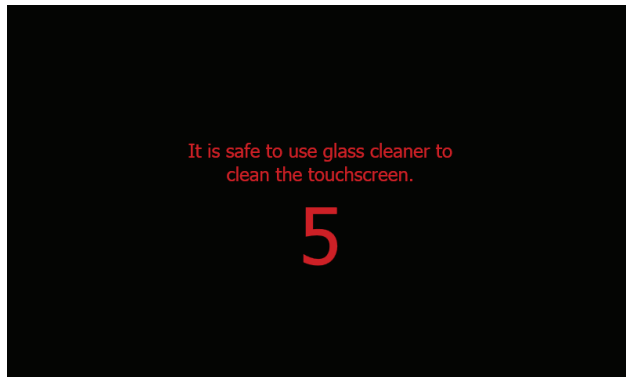


### Cleaning the Display

On the Settings screen, click **Clean Display**. The TD7 is disabled for 5 seconds to allow screen cleaning without response to touch. During this time, the screen is black with a number in the center that counts down the

seconds. After 5 seconds, the display will return to the Settings screen.

**Figure 47. Cleaning the display — countdown screen**



## Security Settings

Security settings are available to prevent unauthorized changes to the system. To access security, click **Security** button on the Settings screen.

### Logging In

All data can be viewed without logging in. However, if security is enabled, the Tracer® AdaptiView™ requires a four-digit security PIN log-in to make changes to any settings protected by security. This feature prevents unauthorized personnel from making changes to the system. Two levels of security are provided.

- **Security Level 1:** Allows users to change a limited group of secure settings. The default security PIN is 1111.
- **Security Level 2:** Allows users to change all secure settings. The default security PIN is 7123.

Tracer® TU service tool is used to set an alternate PIN, or to recall a forgotten pin. When defining a PIN in Tracer® TU, enter a 4-digit PIN to correspond with the desired level of security.

To log in, click **Log In** button, and use the keypad to enter your pin. See figure below.

- PIN is a four-digit number, which was configured for your system with the Tracer® TU service tool.
- For security, the PIN is hidden by asterisks during entry.

**Note:** If an invalid PIN is entered, an error message will appear.

Click **Save**. User will be returned to previous screen.

**Note:** User will be logged out after 30 minutes of inactivity. To manually log out, see section later

**Figure 48. Log in screen**



## Disabling/Enabling Security

The security feature that allows a user to log in or out can be disabled or enabled.

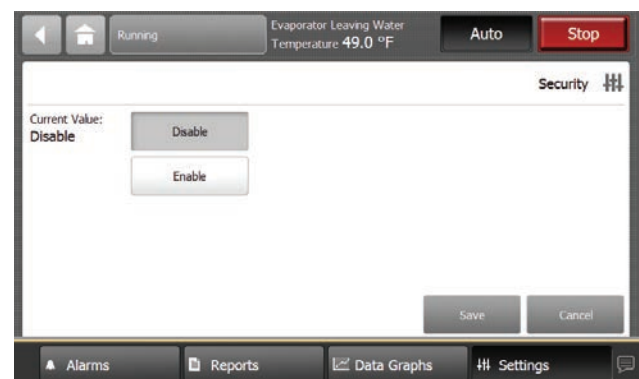
To **disable** security, user must be logged in:

- On Settings screen, click **Security** button.

**Note:** Log in prompt will appear if user is not already logged in.

- Click **Disable** button, then click **Save**.

**Figure 49. Security screen — disable**

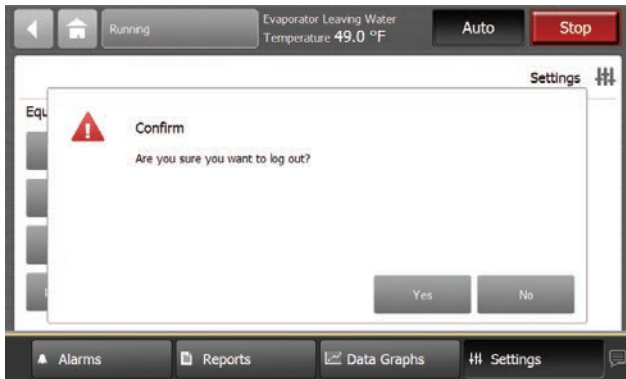


To **enable** security:

- On Settings screen, click **Security** button. The Settings screen will now appear with only the Security button. It will not have a Log In/Log Out buttons
- Click **Enable** button, then click **Save**. The Settings screen will now appear with Log In/Log Out button, in addition to the Security button.

## Logging Out

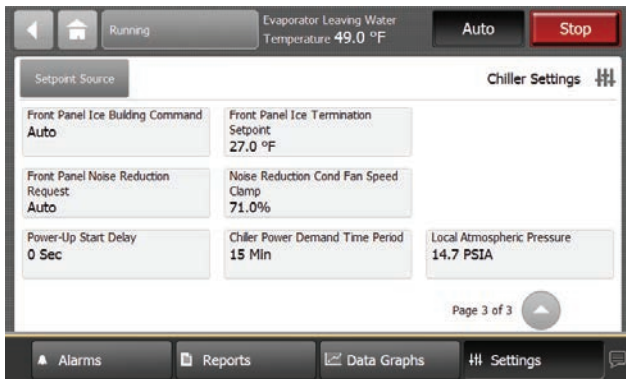
To log out, click **Log Out** button. A confirmation screen appears as shown below. Click **Yes** to confirm.

**Figure 50. Log out confirmation screen**


## InvisiSound Ultimate — Noise Reduction Mode

When the InvisiSound™ Ultimate option is selected (model number digit 12=3), noise reduction mode can be enabled to adjust fan speed and lower maximum sound levels. Reduced acoustic noise levels can be set for certain times, or on a schedule. The noise reduction feature can be requested by local time of day scheduling, external input or building automation system.

To enable this function at the external display, access the Settings screen on the Tracer@ AdaptiView™. See figure below.

**Figure 51. Noise reduction mode settings**


- Set the Front Panel Noise Reduction Request to ON.
- Adjust the Noise Reduction Condenser Fan Speed Clamp to desired value.
  - Setting for fan speed: Percentage of 920 rpm maximum fan speed (Example: For fan speed of 700 rpm, enter a value of 76%)
  - Acceptable inputs are 60% (552 rpm) to 100% (920 rpm) in 1% increments

## Tracer TU

The AdaptiView™ TD7 operator interface allows for daily operational tasks and setpoint changes. However, to adequately service chillers, Tracer@ TU service tool is required. (Non-Trane personnel, contact your local Trane office for software purchase information.)

Tracer@ TU adds a level of sophistication that improves service technician effectiveness and minimizes chiller downtime. This portable PC-based service-tool software supports service and maintenance tasks, and is required for software upgrades, configuration changes and major service tasks.

Tracer@ TU serves as a common interface to all Trane@ chillers, and will customize itself based on the properties of the chiller with which it is communicating. Thus, the service technician learns only one service interface.

The panel bus is easy to troubleshoot using LED sensor verification. Only the defective device is replaced. Tracer@ TU can communicate with individual devices or groups of devices.

All chiller status, machine configuration settings, customizable limits, and up to 100 active or historic diagnostics are displayed through the service-tool software interface.

LEDs and their respective Tracer@ TU indicators visually confirm the availability of each connected sensor, relay, and actuator.

Tracer@ TU is designed to run on a customer's laptop, connected to the Tracer@ AdaptiView™ control panel with a USB cable. Your laptop must meet the following hardware and software requirements:

- 1 GB RAM (minimum)
- 1024 x 768 screen resolution
- CD-ROM drive
- Ethernet 10/100 LAN card
- An available USB 2.0 port
- Windows 7 Enterprise or Professional operating system (32-bit or 64-bit)

**Note:** Tracer@ TU versions 8.6 and earlier will also support Microsoft® Windows® XP Professional operation system with Service Pack 3 (SP3) .

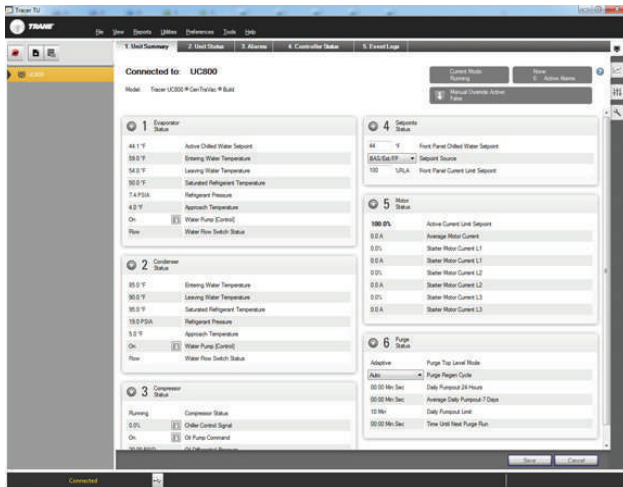
- Microsoft .NET Framework 4.0 or later

### Notes:

- Tracer@ TU is designed and validated for this minimum laptop configuration. Any variation from this configuration may have different results. Therefore, support for Tracer TU is limited to only those laptops with the configuration previously specified.
- For more information, see TTU-SVN01\*-EN Tracer@TU Getting Started Guide



Figure 52. Tracer TU



## Integrated Rapid Restart

Chiller controls are designed and engineered for Rapid Restart™. In the event of a power interruption, the chiller will start a compressor before the front panel display is fully powered up, eliminating the need for an uninterrupted power supply (UPS). Advanced features and functionality are built into the chillers. Bringing a chiller back online rapidly after a loss of power is critical to operations in mission critical environments, which demand the highest levels of reliability.

Under optimal conditions, it can restart in as little as 45 seconds with no need for uninterrupted power supply (UPS). An 80 percent cooling load can be achieved in less than 2.5 minutes after power restoration.



## Pre-Start

Upon completion of installation, complete the Installation Completion Check Sheet and Request for Trane Service checklist in Log and Check Sheet chapter.

***Important:*** Start-up must be performed by Trane or an agent of Trane specifically authorized to perform start-up and warranty of Trane products. Contractor shall provide Trane (or an agent of Trane specifically authorized to perform start-up) with notice of the scheduled start-up at least two weeks prior to the scheduled start-up.



# Start-up and Shutdown

**Important:** Initial unit commissioning start-up must be performed by Trane or an agent of Trane specifically authorized to perform start-up and warranty of Trane products. Contractor shall provide Trane (or an agent of Trane specifically authorized to perform start-up) with notice of the scheduled start-up at least two weeks prior to the scheduled start-up.

## Unit Start-up

### NOTICE

#### Equipment Damage!

Failure to follow instructions could result in equipment damage.

Ensure that the compressor and oil sump heaters have been operating properly for a minimum of 24 hours before starting.

If required, once the system has been operating for approximately 30 minutes and has become stabilized, complete the remaining start-up procedures, as follows:

1. Check the evaporator refrigerant pressure and the condenser refrigerant pressure under Refrigerant Report on the AdaptiView™ TD7. The pressures are referenced to sea level (14.6960 psia).
2. Check the EXV sight glasses after sufficient time has elapsed to stabilize the chiller. The refrigerant flow past the sight glasses should be clear. Bubbles in the refrigerant indicate either low refrigerant charge or excessive pressure drop in the liquid line or a stuck open expansion valve. A restriction in the line can sometimes be identified by a noticeable temperature differential between the two sides of the restriction. Frost will often form on the line at this point. Proper refrigerant charges are shown in the General Information Section.

**Important:** A clear sight glass alone does not mean that the system is properly charged. Also check system subcooling, liquid level control and unit operating pressures.

If chiller is limited by any limiting conditions, contact local Trane service organization for more information.

## Temporary Shutdown And Restart

To shut the unit down for a short time, use the following procedure:

1. Press the STOP key on the AdaptiView™ TD7. The compressors will continue to operate and an operational pumpdown cycle will be initiated.

2. UC800 pump control will turn off the pump (after a minimum 1 min. delay) when the STOP key is pressed and automatically restart the pump when the unit starts normally.

To restart the unit after a temporary shutdown, enable the chilled-water pump and press the AUTO key. The unit will start normally, provided the following conditions exist:

- The UC800 receives a call for cooling and the differential-to-start is above the setpoint.
- All system operating interlocks and safety circuits are satisfied.

## Extended Shutdown Procedure

The following procedure is to be followed if the system is to be taken out of service for an extended period of time, e.g. seasonal shutdown:

1. Test the unit for refrigerant leaks and repair as necessary.
2. Open the electrical disconnect for the chilled water pump. Lock the switches in the "OPEN" position.

### NOTICE

#### Pump Damage!

Failure to follow instructions could result in pump damage.

Lock the chilled water pump disconnects open and verify pump is off before draining water.

3. Close all chilled water supply valves. Drain the water from the evaporator.
4. With the water drained from evaporator, disconnect 115 power from evaporator heaters at terminals 1X4-1 and 1X4-2.

### NOTICE

#### Heater Damage!

Failure to follow instructions could result in heater damage.

Do not apply power to the evaporator heaters when no water is present.

5. Open the main electrical disconnect and lock in the "OPEN" position.



**NOTICE**

**Equipment Damage!**

Failure to follow instructions could result in equipment damage.

Lock the disconnect in the "OPEN" position to prevent accidental start-up and damage to the system when it has been shut down for extended periods.

6. At least every three months (quarterly), check the refrigerant pressure in the unit to verify that the refrigerant charge is intact.

## Seasonal Unit Start-up Procedure

1. PRIOR to water being pumped into system, use gauges to verify positive pressure in the evaporator and condenser. Lack of pressure could indicate a system leak. When charging in the factory, approximately 95% of the refrigerant charge is isolated in the evaporator, and the other 5% is contained in the condenser and compressor. In the event that no pressure is present, contact local Trane service.
2. Close all drain valves and re-install the drain plugs in the evaporator.
3. Service the auxiliary equipment according to the start-up/maintenance instructions provided by the respective equipment manufacturers.
4. Close the vents in the evaporator chilled water circuits.
5. Open all the valves in the evaporator chilled water circuits.
6. Open all refrigerant valves or verify they are in the open condition.
7. If the evaporator was previously drained, vent and fill the evaporator and chilled water circuit. When all air is removed from the system (including each pass), install the vent plugs in the evaporator water boxes.
8. Check the adjustment and operation of each safety and operating control.
9. Refer to the sequence for daily unit startup for the remainder of the seasonal startup.

## System Restart After Extended Shutdown

**NOTICE**

**Equipment Damage!**

Failure to follow instructions could result in equipment damage.

Ensure that the compressor and oil sump heaters have been operating properly for a minimum of 24 hours before starting.

Follow the procedures below to restart the unit after extended shutdown:

1. Check refrigerant pressure as noted in Seasonal Unit Start-Up procedure.
2. Verify that the liquid line service valves, oil line, compressor discharge service valves and suction service valves are open (backseated).

**NOTICE**

**Compressor Damage!**

Failure to follow instructions below could cause catastrophic damage to the compressor.

Do not leave oil line shut off valve or the isolation valves closed on unit start-up.

3. Check the oil sump level. See instructions in Maintenance chapter.
4. Fill the evaporator water circuit. Vent the system while it is being filled. Open the vent on the top of the evaporator and condenser while filling and close when filling is completed.

**NOTICE**

**Proper Water Treatment Required!**

The use of untreated or improperly treated water could result in scaling, erosion, corrosion, algae or slime.

Use the services of a qualified water treatment specialist to determine what water treatment, if any, is required. Trane assumes no responsibility for equipment failures which result from untreated or improperly treated water, or saline or brackish water.

5. Close the fused-disconnect switches that provides power to the chilled water pump.
6. Start the evaporator water pump and, while water is circulating, inspect all piping for leakage. Make any necessary repairs before starting the unit.
7. While the water is circulating, adjust the water flows and check the water pressure drops through the evaporator. See Evaporator Waterside Pressure Drop Curves in Installation Mechanical chapter, and water flow rates in General Data tables..
8. Verify proper operation of flow switch on the

evaporator waterbox.

- Stop the water pump. The unit is now ready for start-up as described previously

## Sequence of Operation

This section provides basic information on chiller operation for common events. Adaptive control algorithms are used on these chillers. This section illustrates common control sequences.

### Software Operation Overview

The following figure is a diagram of the five possible software states. This diagram can be thought of as a state chart, with the arrows and arrow text, depicting the transitions between states:

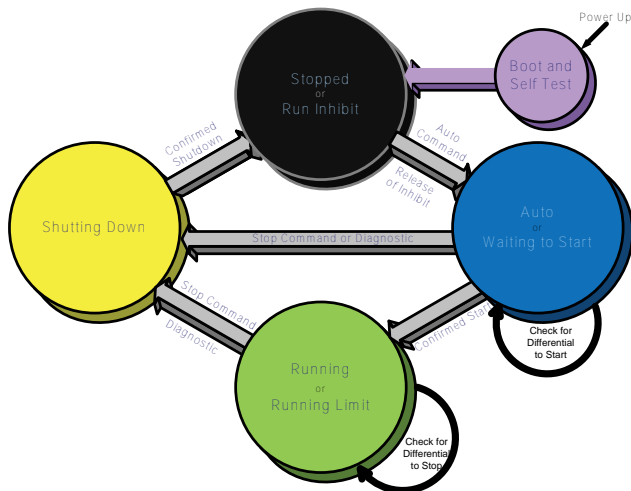
- The text in the circles is the internal software designations for each state.
- The shading of each software state circle corresponds to the shading on the time lines that show the chiller's state.

There are five generic states that the software can be in:

- Power Up
- Stopped
- Starting
- Running
- Stopping

In the following diagrams:

- The time line indicates the upper level operating mode, as it would be viewed in the Tracer® AdaptiView™.
- The shading color of the cylinder indicates the software state.
- Text in parentheses indicates sub-mode text as viewed in the Tracer® AdaptiView™.
- Text above the time line cylinder is used to illustrate inputs to the UC800. This may include user input to the Tracer® AdaptiView™ touch screen, control inputs from sensors, or control inputs from a generic BAS.
- Boxes indicate control actions such as turning on relays, or pulsing compressor load or unload solenoids.
- Smaller cylinders under the main cylinder indicate diagnostic checks.
- Text outside a box or cylinder indicates time-based functions.
- Solid double arrows indicate fixed timers.
- Dashed double arrows indicate variable timers.

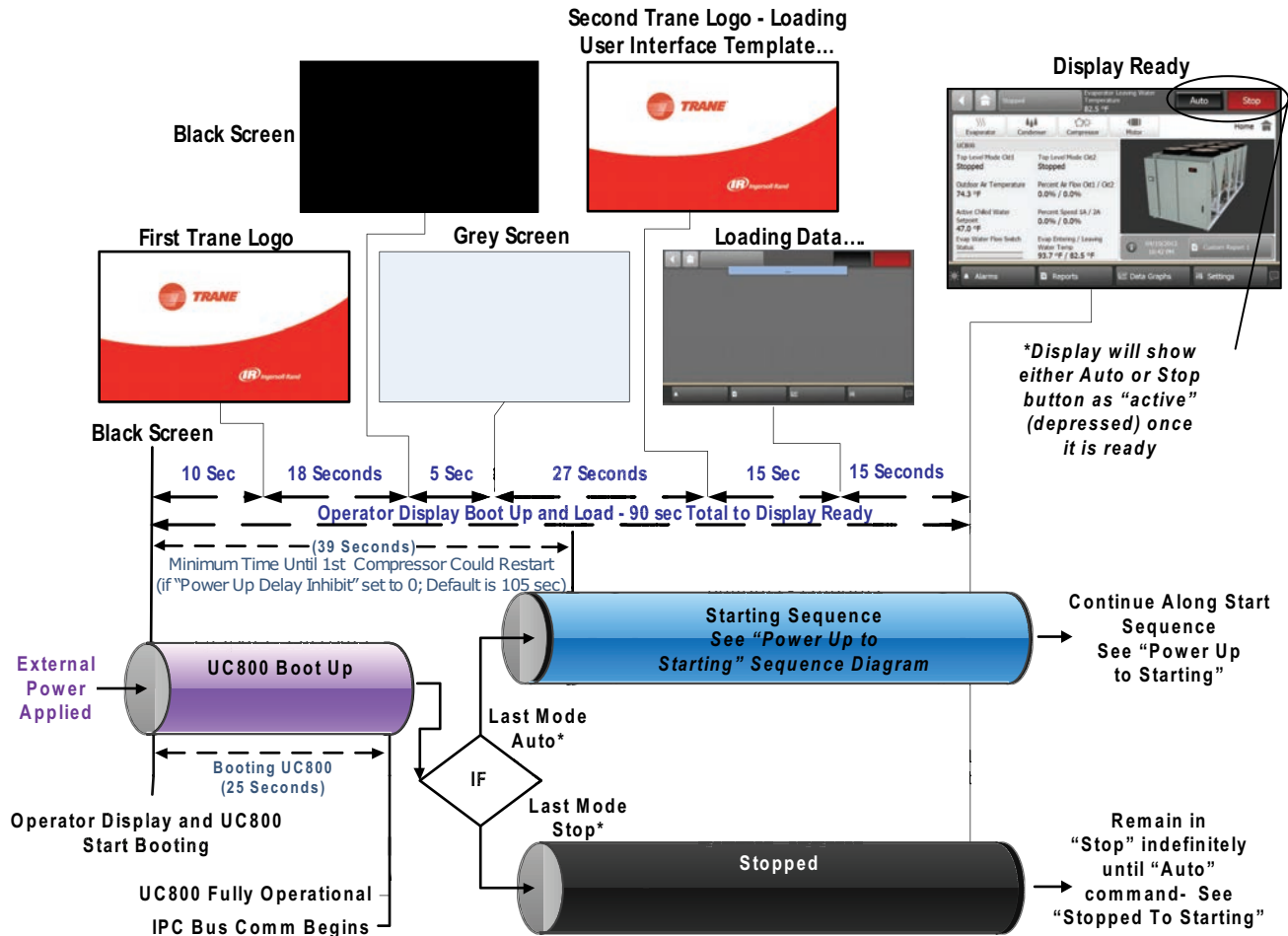


## Power Up Diagram

The following diagram shows the respective TD7 AdaptiView™ screens during a power up of the UC800 and display. This process takes 25 seconds for the UC800 and 90 seconds for the display. On all power

ups, the software model always will transition through the 'Stopped' Software state independent of the last mode. If the last mode before power down was 'Auto', the transition from 'Stopped' to 'Starting' occurs, but it is not apparent to the user.

Figure 53. Sequence of operation: power up diagram



## Power Up to Starting

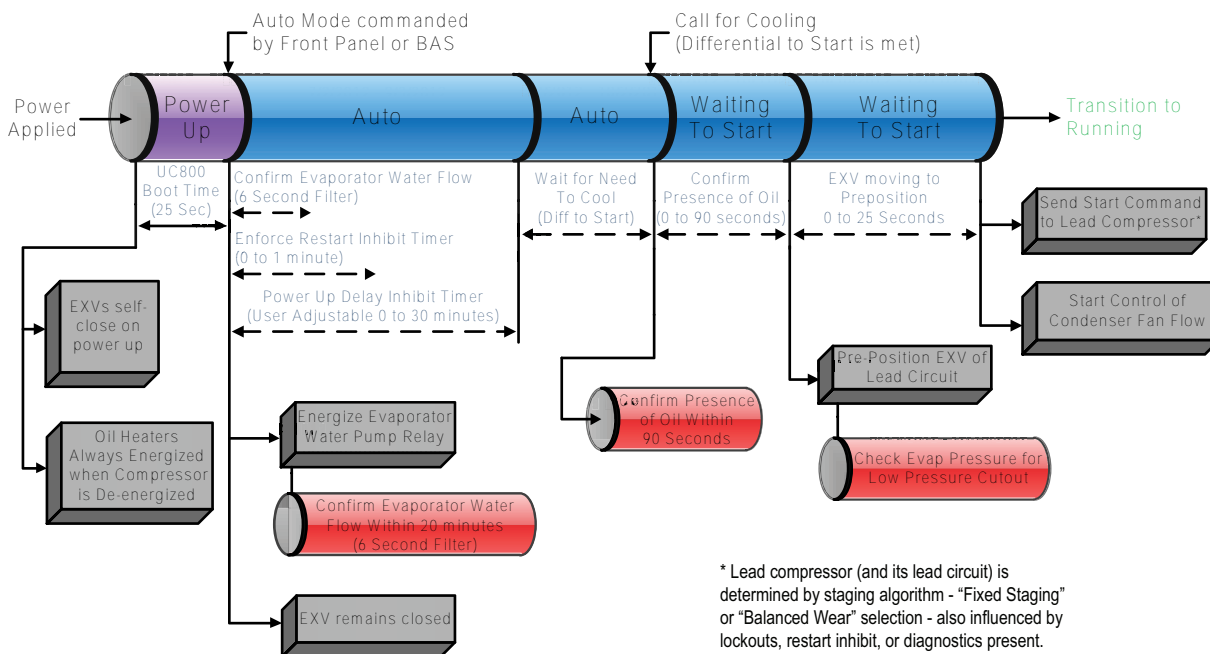
The following diagram shows the timing from a power up event to energizing the first compressor. The shortest allowable time would be under the following conditions:

- No motor restart inhibit time left from subsequent starts
- Evaporator Water flow occurs quickly with pump on command

- Power up Start Delay set to 0 minutes
- Need to cool (differential to start) already exists
- Oil level is detected immediately

The above conditions would allow for a minimum power up to starting the first compressor time of about 45 seconds (variations may exist due to options installed). Note that it is not advisable to start a chiller "cold", the oil heaters should be in operation for a sufficient length of time prior to first start.

**Figure 54. Sequence of events: power up to starting**



## Start-up and Shutdown

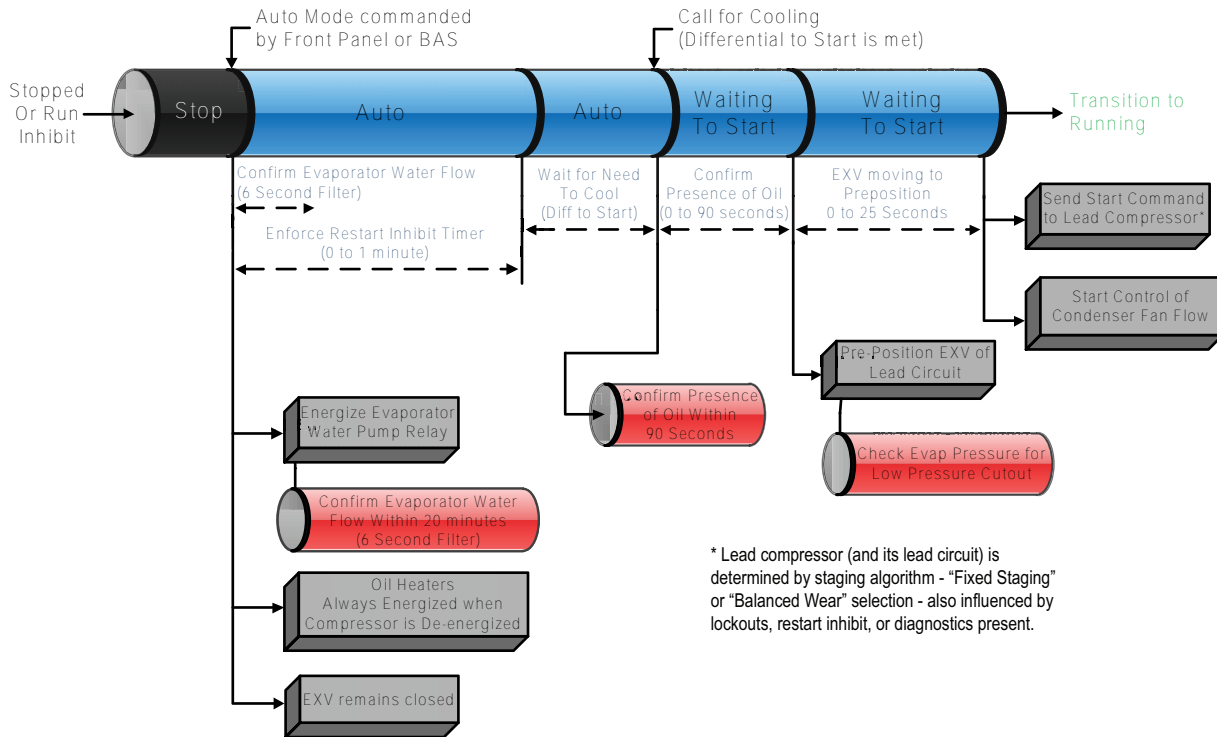
### Stopped to Starting

The following diagram shows the timing from a stopped mode to energizing the first compressor. The shortest allowable time would be under the following conditions:

- No motor restart inhibit time left from subsequent starts

- Evaporator Water flow occurs quickly with pump on command
- Need to cool (differential to start) already exists
- The above conditions would allow a compressor to start in about 20 seconds.

**Figure 55. Sequence of events: stopped to starting**

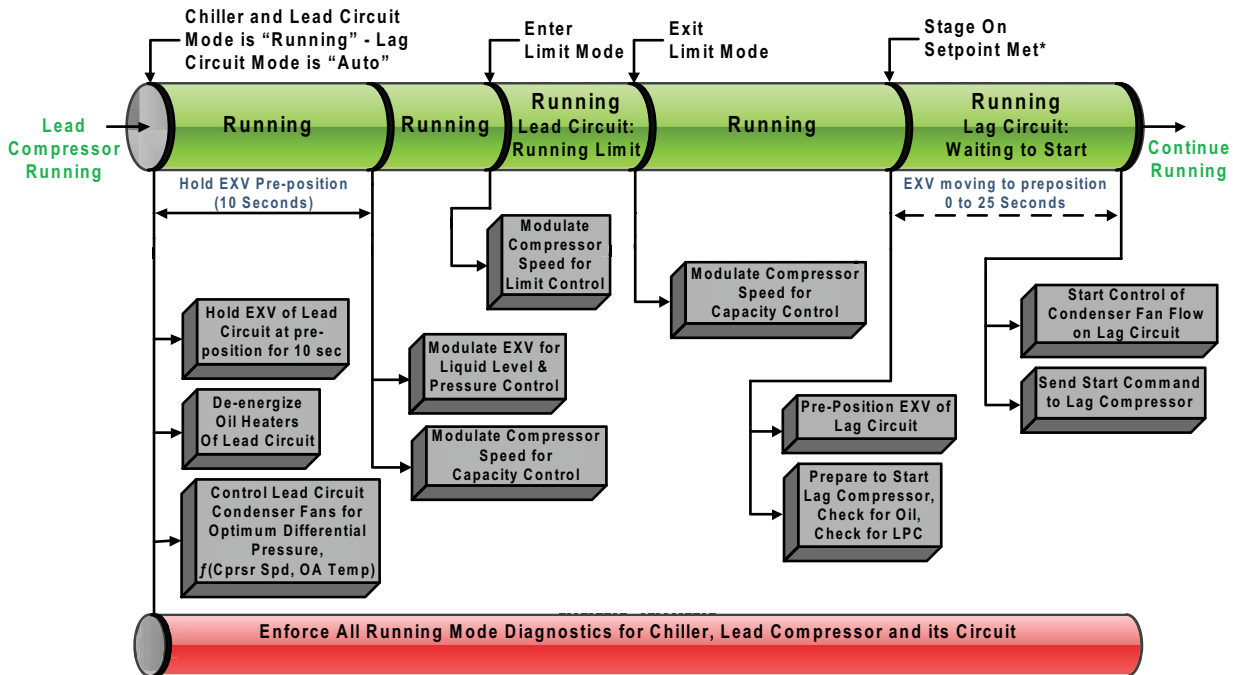




## Running (Lead Compressor/Circuit Start and Run)

The following diagram shows a typical start and run sequence for the lead compressor and its circuit.

Figure 56. Sequence of operation: running (lead compressor/circuit start and run)

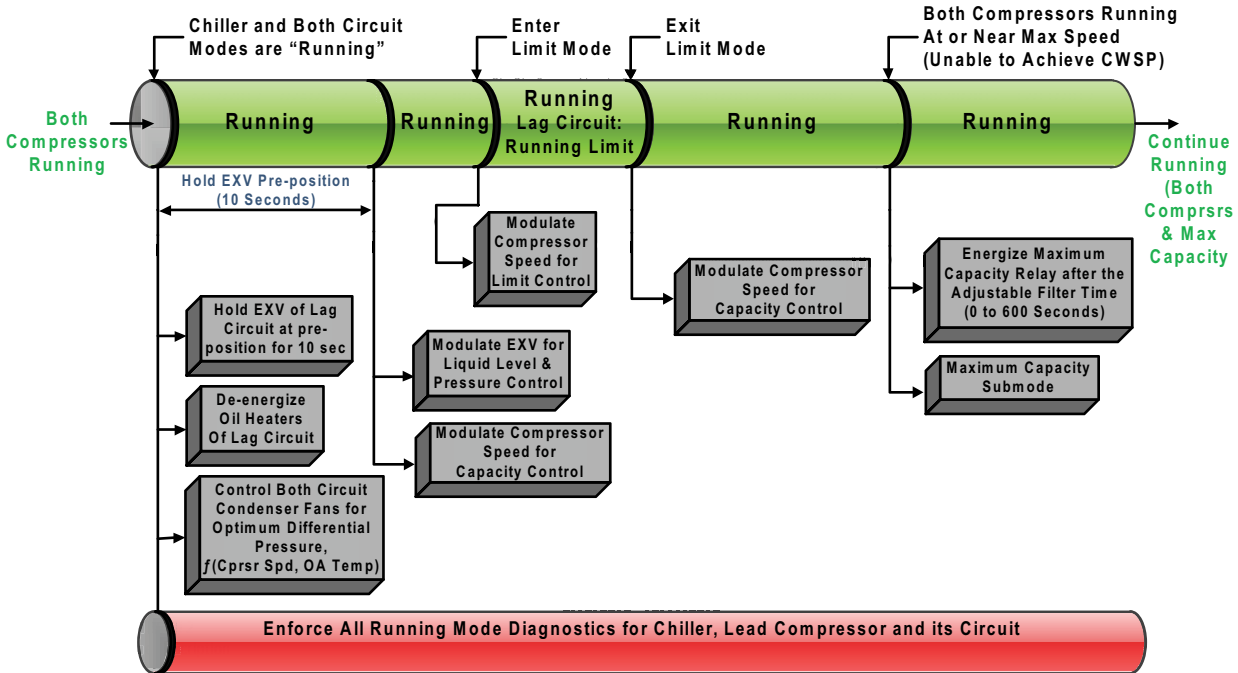


\*Note: The decision to stage on or off another compressor is determined by the Average Running Compressor Load Command, Water Temperature Error, and Time Since Last Stage

## Running (Lag Compressor/Circuit Start and Run)

The following diagram shows a typical start and run sequence for the lag compressor and its circuit.

**Figure 57. Sequence of operation: running (lag compressor/circuit start and run)**



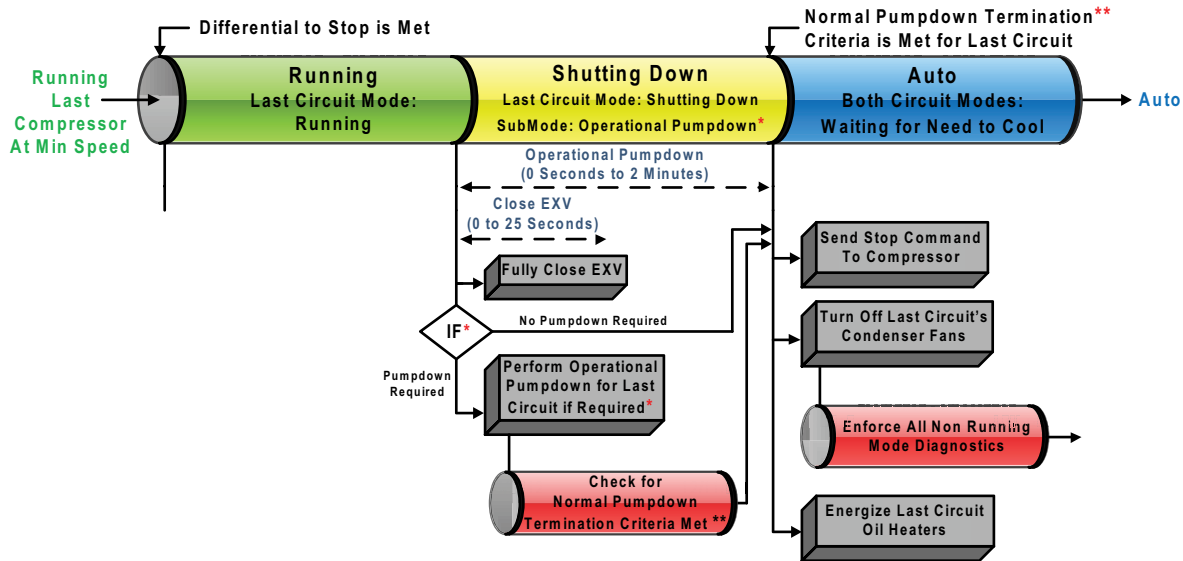
\*Note: The decision to stage on or off another compressor is determined by the Average Running Compressor Load Command, Water Temperature Error, and Time Since Last Stage

## Satisfied Setpoint

The following diagram shows the normal transition from Running to shutting down due to the Evap

Leaving water temp falling below the differential to stop setpoint.

**Figure 58. Sequence of events: satisfied setpoint**



\* Note: Operational Pumpdown is required if the Outdoor Air Temperature is less than 50F.

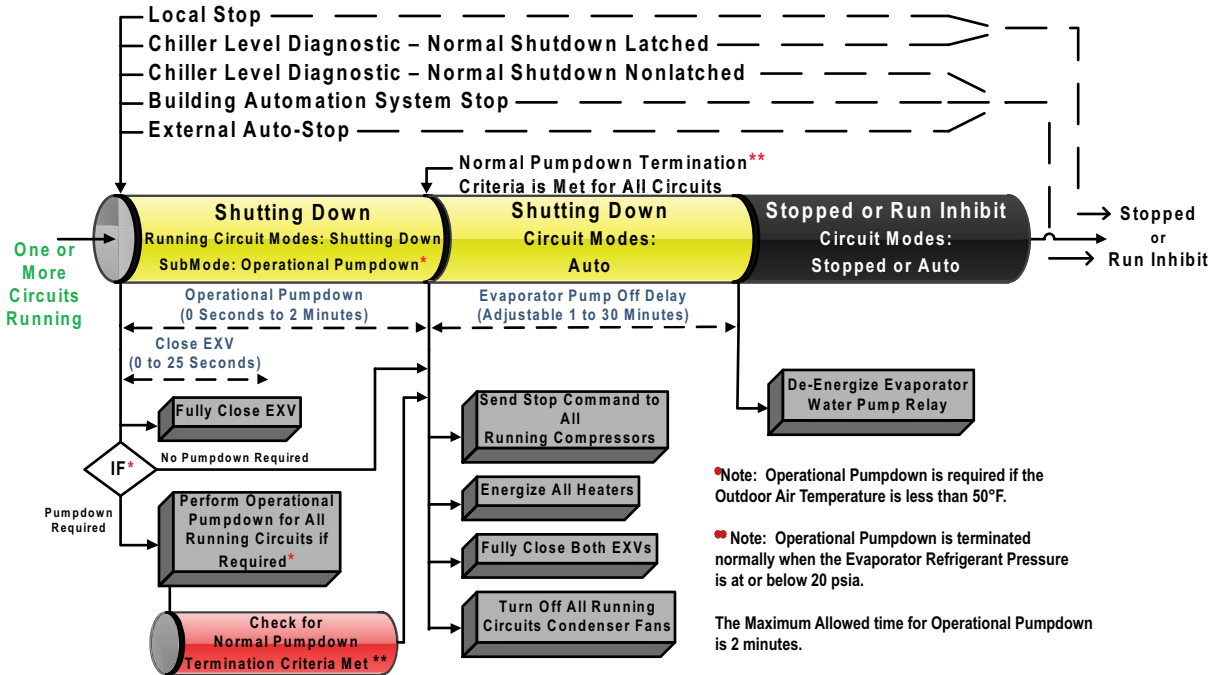
\*\* Note: Operational Pumpdown is Terminated Normally when the Evaporator Refrigerant Pressure is at or below 20 PSIA. The Maximum Allowed Time for Operational Pumpdown is 2 Minutes.

## Normal Shutdown to Stopped or Run Inhibit

dashed lines on the top attempt to show the final mode if stop is selected via various inputs.

The following diagram shows the Transition from Running through a Normal (friendly) Shutdown. The

**Figure 59. Sequence of events: normal shutdown to stopped or run inhibit**



\* Note: Operational Pumpdown is required if the Outdoor Air Temperature is less than 50F.

\*\* Note: Operational Pumpdown is Terminated Normally when the Evaporator Refrigerant Pressure is at or below 20 PSIA. The Maximum Allowed Time for Operational Pumpdown is 2 Minutes.

\*Note: Operational Pumpdown is required if the Outdoor Air Temperature is less than 50°F.

\*\* Note: Operational Pumpdown is terminated normally when the Evaporator Refrigerant Pressure is at or below 20 psia.

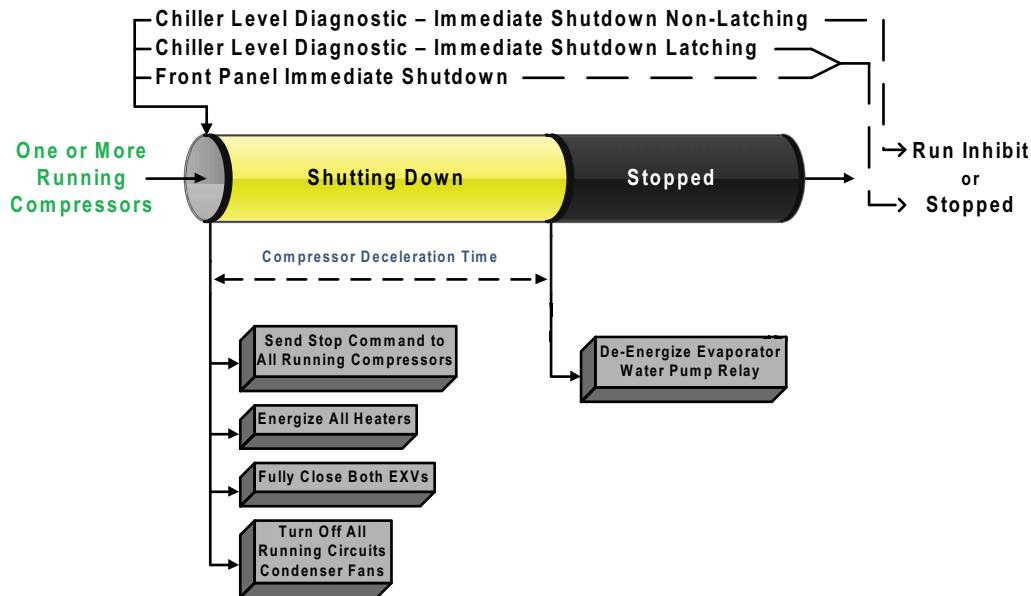
The Maximum Allowed time for Operational Pumpdown is 2 minutes.

## Immediate Shutdown to Stopped or Run Inhibit

lines on the top attempt to show the final mode if stop is selected via various inputs.

The following diagram shows the Transition from Running through an Immediate Shutdown. The dashed

**Figure 60. Sequence of events: immediate shutdown to stopped or run inhibit**

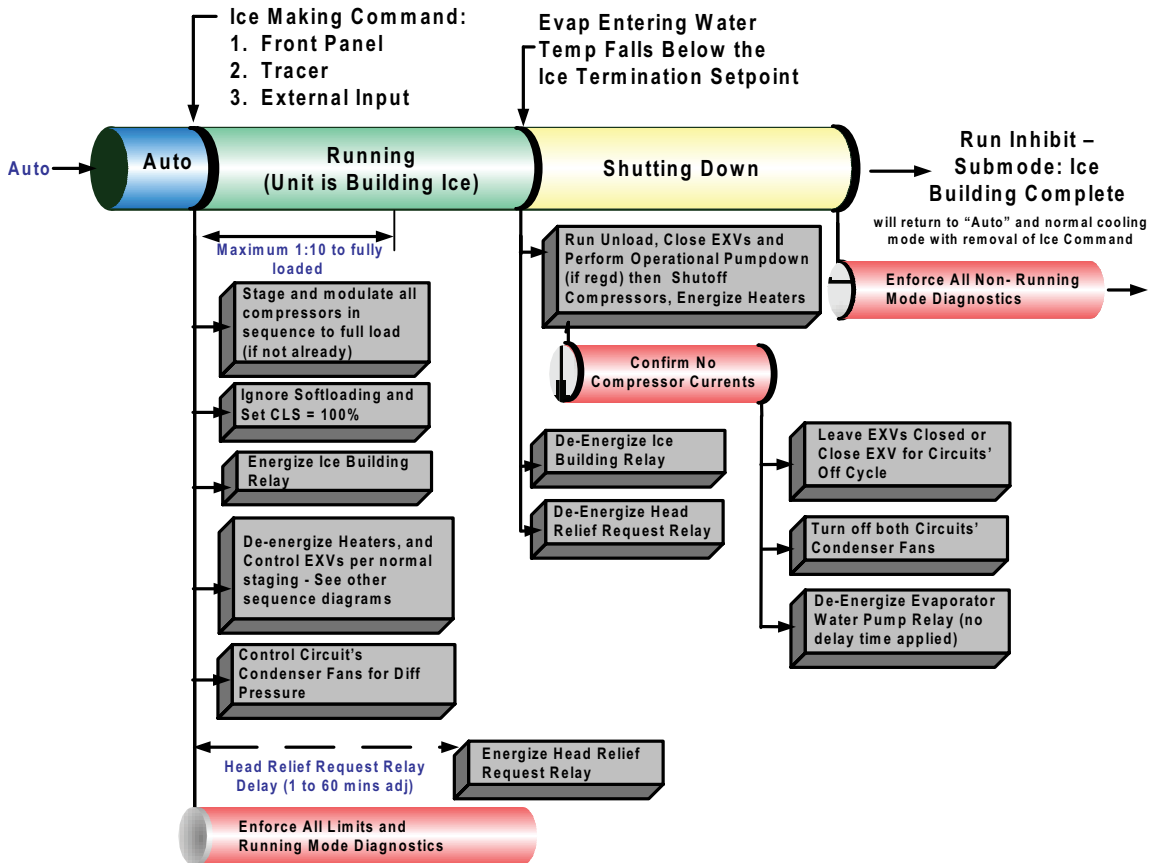




### Ice Making (Auto to Ice Making to Ice Making Complete)

The following diagram shows the transition from Auto to Ice making, to Ice Making Complete.

Figure 62. Sequence of events: ice making (auto to ice making to ice making complete)





# Maintenance

## ⚠ WARNING

### Hazardous Voltage - Pressurized Flammable Fluid!

Failure to follow all electrical safety precautions could result in death or serious injury.

Do not operate compressor without terminal box cover in place.

The motors in the compressors have strong permanent magnet motors and have the capability to generate voltage during situations when the refrigerant charge is being migrated. This potential will be present at the motor terminals and at the output of the variable speed drives in the power panel.

Before removing compressor terminal box cover for servicing, or servicing power side of control panel, CLOSE COMPRESSOR DISCHARGE SERVICE VALVE and disconnect all electric power including remote disconnects. Discharge all motor start/run capacitors. Follow lockout/tagout procedures to ensure the power cannot be inadvertently energized. Verify with an appropriate voltmeter that all capacitors have discharged.

The compressor contains hot, pressurized refrigerant. Motor terminals act as a seal against this refrigerant. Care should be taken when servicing NOT to damage or loosen motor terminals.

## ⚠ WARNING

### Pressurized Burning Fluid!

Failure to follow the instructions below could result in death or serious injury.

Do not operate compressor without terminal box cover in place.

The compressor contains hot, pressurized refrigerant. Motor terminals act as a seal against this refrigerant. Care should be taken when servicing NOT to damage or loosen motor terminals.

## ⚠ WARNING

### Hazardous Voltage w/Capacitors!

Failure to follow these instructions could result in death or serious injury.

Disconnect all electric power, including remote disconnects and discharge all motor start/run and AFD (Adaptive Frequency™ Drive) capacitors before servicing. Follow proper lockout/tagout procedures to ensure the power cannot be inadvertently energized.

- For variable frequency drives or other energy storing components provided by Trane or others, refer to the appropriate manufacturer's literature for allowable waiting periods for discharge of capacitors. Verify with an appropriate voltmeter that all capacitors have discharged.
- DC bus capacitors retain hazardous voltages after input power has been disconnected. Follow proper lockout/tagout procedures to ensure the power cannot be inadvertently energized. After disconnecting input power, wait five (5) minutes for the DC capacitors to discharge, then check the voltage with a voltmeter. Make sure DC bus capacitors are discharged (0 VDC) before touching any internal components.

*For additional information regarding the safe discharge of capacitors, see Adaptive Frequency™ Drive Capacity Discharge section, and PROD-SVB06\*-EN.*

This section describes the basic chiller preventive maintenance procedures, and recommends the intervals at which these procedures should be performed. Use of a periodic maintenance program is important to ensure the best possible performance and efficiency.

Use an Operator Log (see Log and Check Sheet chapter) to record an operating history for unit. The log serves as a valuable diagnostic tool for service personnel. By observing trends in operating conditions, an operator can anticipate and prevent problem situations before they occur.

If unit does not operate properly during inspections, see Diagnostics chapter.

## Recommended Maintenance

### Weekly

While unit is running in stable conditions.

1. At AdaptiView™ TD7 or Tracer® TU service tool, check pressure for evaporator, condenser and



intermediate oil.

2. Observe liquid line sight glass on EXV. If liquid line sight glass has bubbles measure the subcooling entering the EXV. Subcooling should always be greater than 10°F.
3. Inspect the entire system for unusual operation.
4. Inspect the condenser coils for dirt and debris. If the coils are dirty, see Condenser Coil Cleaning section of Maintenance chapter.

### NOTICE

#### **Coil Damage!**

**Use of detergents could cause damage to coils. Do not use detergents to clean coils. Use clean water only.**

### Monthly

1. Perform all weekly maintenance procedures.
2. Record the system subcooling.

### Annual

1. Perform all weekly and monthly procedures.
2. Check oil level while unit is off. See Maintenance chapter.
3. Perform pH test of drive cooling fluid. See pH Test section of Maintenance chapter.
4. Have a qualified laboratory perform a compressor oil analysis to determine system moisture content and acid level.
5. Contact a Trane service organization to leak test the chiller, to check operating and safety controls, and to inspect electrical components for deficiencies.
6. Clean and repaint any areas that show signs of corrosion.
7. Clean the condenser coils. See Condenser Coil Cleaning section of Maintenance chapter.

### NOTICE

#### **Coil Damage!**

**Use of detergents could cause damage to coils. Do not use detergents to clean coils. Use clean water only.**

## Refrigerant and Oil Charge Management

Proper oil and refrigerant charge is essential for proper unit operation, unit performance, and environmental protection. Only trained and licensed service personnel should service the chiller.

The following table lists baseline measurements for chillers running at AHRI standard operating conditions.

If chiller measurements vary significantly from values listed below, problems may exist with refrigerant and oil charge levels. Contact your local Trane office.

**Note:** *Low temperature applications units will have values that vary from the following table. Contact your local Trane office for more information.*

**Table 28. Typical baselines (AHRI conditions)**

Measurement	Baseline
Evaporator Pressure	51 psia
Evaporator Approach	3.4°F
EXV Position (150 to 200T units)	45-50% open
EXV Position (225 to 300T units)	61-64% open
Evaporator $\Delta T$ - entering	54°F
Evaporator $\Delta T$ - leaving	44°F
Discharge Superheat	16.5°F
Condenser Pressure	212 psia
Subcooling	10 to 20°F

## Lubrication System

The lubrication system has been designed to keep most of the oil lines filled with oil as long as there is a proper oil level in the oil sump.

### Oil Sump Level Check

The oil level in the sump can be measured to give an indication of the system oil charge. Follow the procedures below to measure the level.

1. Run the unit as near to full load as possible for a minimum of 30 minutes. For an accurate reading, 40 or more minutes at full load with normal/steady discharge superheat readings and no limits/warnings is recommended. Assessing oil charge after running at minimum or low loads may lead to an inaccurate reading.
2. Cycle the compressor off line.
3. Let the chiller sit (powered, but off line) to allow the oil separator heater to boil off the refrigerant that may be in the oil separator. An initial assessment of the oil separator level may be made after 30 minutes of heater ON dwell time, but oil charge adjustments should not be made without allowing the oil heaters to run for a minimum of 4 hours.

**NOTICE**

**Equipment Damage!**

Operating compressors with service valves open will result in severe oil loss and equipment damage.

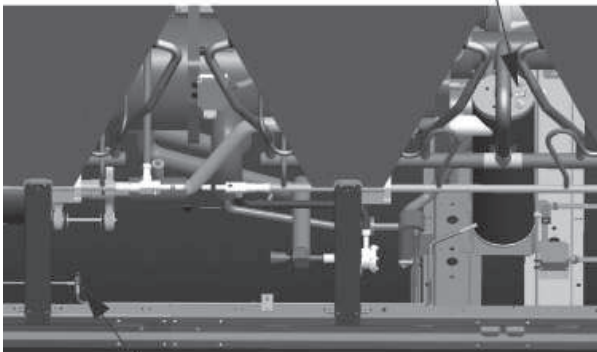
Never operate the compressor with the sight glass service valves opened. Close the valves after checking the oil level.

- Attach a 3/8" or 1/2" hose with a sightglass in the middle to the oil sump service valve (1/4" flare) and the oil separator service valve (1/4" flare). See the following figure for valve locations.

*Note: High pressure rated clear hose with appropriate fittings can help speed up the process. Hose must be rated to withstand system pressures as found on unit nameplate.*

Figure 63. Oil service valves

To Oil Separator Service Valve



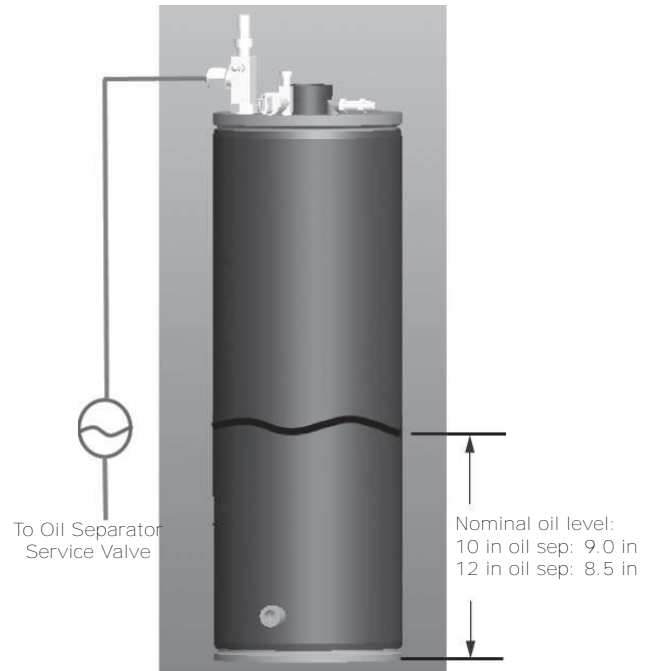
Oil Service Valve

- After the unit is off line for 30 minutes, move the sightglass along the side of the oil sump.
- The nominal oil level from the bottom of the oil separator should be as shown in the following table and figure. Depending on running conditions and oil heater dwell time, some deviation from nominal levels is expected.

*Important: If level is less than 4 inches from the bottom of the oil separator, contact your local Trane office.*

Unit Size (tons)	Oil Separator Size (in)	Nominal Oil Charge Height (in)
150 to 200	10	9.0
225 to 300	12	8.5

Figure 64. Nominal oil level



**Drive Cooling System**

**NOTICE**

**Equipment Damage!**

Use of unapproved fluids, or dilution of approved fluid could result in catastrophic equipment damage.

Use only Trane Heat Transfer Fluid P/N CHM01023. This fluid is a direct use concentration and is not to be diluted. Do not top off with water or any other fluid.

**Service Intervals**

**NOTICE**

**Equipment Damage!**

Failure to follow instructions could result in equipment damage.

Drive cooling fluid and strainer must be serviced every five (5) years.

- Every (5) years, contact your local Trane office to service drive fluid and strainer.
- On a yearly basis, a fluid pH test should be performed.

**Unit Diagnostics**

An improperly filled drive cooling system (either low fluid level or entrapped air in the circuit) can result in the AFD drive overheating. This condition may result in the following diagnostic(s):

- AFD xA Over Temperature

A front panel warning of Low Oil Return or AFD Cooling – CktX does not indicate an issue with the drive cooling fluid system, but represents a low refrigerant level reported by the liquid level sensor for a given length of time.

If chiller diagnostics indicated drive cooling system problem, contact your local Trane office.

### pH Test

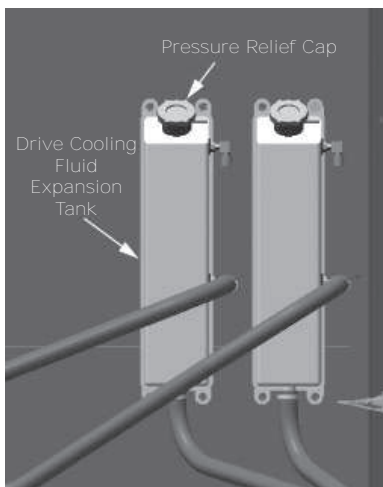
Obtain a sample of fluid from the drive cooling loop via the loop drain located near the oil return heat exchanger. Test for pH level using litmus paper with a 0.5 resolution.

- pH < 8 indicates fluid to be changed
- pH < 7 indicates potential component damage

### Pressure Relief Cap

The pressure relief cap is an automotive style pressure-vent radiator cap. See figure below. The setting for the relief spring is 16 lbs. The function of the relief cap can be verified with a standard automotive radiator cap tester.

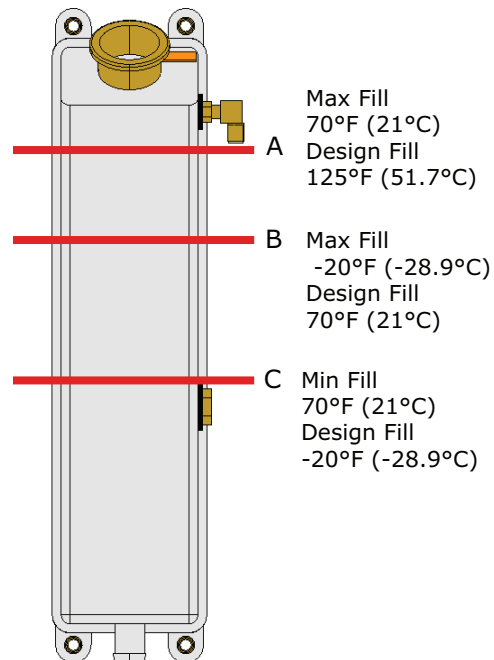
Figure 65. Pressure relief cap



### Drive Cooling Expansion Tank

Proper fluid level is important to the operation of the unit. To verify proper level, inspect the liquid level in each of the fluid reservoirs (located behind the chiller control panel). See figure below for fluid levels under various temperature conditions. If levels are low, contact your local Trane office.

Figure 66. Drive cooling expansion tank fill



**Note:** Fill lines are NOT marked on tank. The A level is just below upper fitting. C level is above lower fitting. B is in the middle of the fittings.

## Condenser Coil Corrosion Protection Inspection

Perform coil inspection each time coils are cleaned.

Inspect corrosion protection at each coil refrigerant connection where the copper tube joins the aluminum manifold. If damaged or missing, wrap new Prestite Insulated tar tape (STR01506) on joint to cover area from the aluminum header body to at least 2 inches of the copper tube. Seal insulation using hand pressure. Rubber gloves are suggested when handling insulation.

**Note:** Prestite insulated tar tape is required for all units at each copper/aluminum connection. This requirement is NOT associated with the coated coil option.

## Condenser Coil Cleaning

For information regarding the proper microchannel coil cleaning procedure, refer to RT-SVB83\*-EN

### Coil Cleaning Interval

Clean condenser coils at least once a year or more frequently if it is in a "dirty" environment. A clean condenser coil will help maintain chiller operating efficiency.



### Cleaning Air Side of Coils

#### **NOTICE**

##### **Coil Damage!**

Use of coil cleaning agents on uncoated coils could cause damage to coils.

Do not use coil cleaning agents to uncoated clean coils. Use clean water only.

Do not use detergents to clean the air side of coils. Use clean water only. Clean from inside out by removing end panels.

### Cleaning Coated Coils

#### **⚠ WARNING**

##### **Hazardous Chemicals!**

Coil cleaning agents can be either acidic or highly alkaline and can burn severely if contact with skin or eyes occurs.

Handle chemical carefully and avoid contact with skin. ALWAYS wear Personal Protective Equipment (PPE) including goggles or face shield, chemical resistant gloves, boots, apron or suit as required. For personal safety refer to the cleaning agent manufacturer's Materials Safety Data Sheet and follow all recommended safe handling practices.

Coated coils may be cleaned using traditional detergents.

### Reinstallation of Compressor Mounting Bolts

Units with InvisiSound™ Ultimate Only (Model Number Digit 12 = 3)

If compressor removal or unit move is required on a unit with InvisiSound™ Ultimate option, reinstall compressor mounting bolts which were removed per installation or maintenance instructions.

### Servicing Chiller Roof

#### **⚠ WARNING**

##### **Do Not Climb on Top of Unit!**

Failure to follow these instructions could result in technician falling off the equipment which could result in death or serious injury.

Do not climb on roof to service unit. Use service tools designed to access top of chiller.

Service tools are available to access top of chiller. Entry on chiller roof is not required.



# Diagnostics

## General Diagnostics Information

**Diagnostic Name and Source:** Name of Diagnostic and its source. The variable "x" in the AFD diagnostic name string denotes a circuit designator (either 1 or 2). With that exception, this is the exact text used in the User Interface and/or Service Tool displays.

**Affects Target:** Defines the "target" or what is affected by the diagnostic. Usually either the entire Chiller, or a particular Circuit or Compressor is affected by the diagnostic (the same one as the source), but in special cases functions are modified or disabled by the diagnostic. "None" implies that there is no direct affect to the chiller, sub components or functional operation.

**Design Note:** Functions that are affected by a diagnostic are simply reported as "chiller or circuit x" targets in Tracer TU and on the Alarms page of the AdaptiView™ display, even though only a specific function and not the entire circuit or chiller would be effected.

**Severity:** Defines the severity of the above effect. Immediate means immediate shutdown of the affected portion, Normal means normal or friendly shutdown of the affected portion, Special Action means a special action or mode of operation (limp along) is invoked, but without shutdown, and Info means an Informational Note or Warning is generated. Design Note: Tracer TU does not support display of "Special Action", on its Diagnostics pages, so that if a diagnostic has a special action defined in the table below, it will be displayed only as "Informational Warning" as long as

no circuit or chiller shutdown results. If there is a shutdown and special action defined in the table, then the Tracer® TU Diagnostics Page display will indicate the shutdown type only.

**Persistence:** Defines whether or not the diagnostic and its effects are to be manually reset (Latched), or can be either manually or automatically reset when and if the condition returns to normal (Nonlatched).

**Active Modes [Inactive Modes]:** States the modes or periods of operation that the diagnostic is active in and, as necessary, those modes or periods that it is specifically "not active" in as an exception to the active modes. The inactive modes are enclosed in brackets, [ ]. Note that the modes used in this column are internal and not generally announced to any of the formal mode displays.

**Criteria:** Quantitatively defines the criteria used in generating the diagnostic and, if nonlatching, the criteria for auto reset.

**Reset Level:** Defines the lowest level of manual diagnostic reset command which can clear the diagnostic. The manual diagnostic reset levels in order of priority are: Local or Remote. For example, a diagnostic that has a reset level of Remote, can be reset by either a remote diagnostic reset command or by a local diagnostic reset command.

## AFD Diagnostics

**Table 29. Diagnostics – AFD**

Diagnostic Name and Source	Affects Target	Severity	Persistence	Active Modes [Inactive Modes]	Criteria	Reset Level
AFD 1A Input Phase Loss	Circuit	Immediate	Latch	All compressor starting and running modes	The respective AFD has detected high ripple on the DC bus indicative of an input phase loss. Suspect open phase, check input voltage and current capability on all legs.	Local
AFD 2A Input Phase Loss	Circuit	Immediate	Latch	All compressor starting and running modes	The respective AFD has detected high ripple on the DC bus indicative of an input phase loss. Suspect open phase, check input voltage and current capability on all legs.	Local
AFD 1A Bus Under Voltage	Circuit	Immediate (decel)	NonLatch	All	The bus voltage dropped below the Under Voltage Level and there is not enough voltage to reliably operate the load, or input voltage was lost on all phases (Power Loss). The drive shall automatically clear this diagnostic if the undervoltage is corrected within 15s, or if a power loss event, when power is restored at any later time.	Local

## Diagnostics

**Table 29. Diagnostics – AFD (continued)**

Diagnostic Name and Source	Affects Target	Severity	Persistence	Active Modes [Inactive Modes]	Criteria	Reset Level
AFD 2A Bus Under Voltage	Circuit	Immediate (decel)	NonLatch	All	The bus voltage dropped below the Under Voltage Level and there is not enough voltage to reliably operate the load, or input voltage was lost on all phases (Power Loss). The drive shall automatically clear this diagnostic if the undervoltage is corrected within 15s, or if a power loss event, when power is restored at any later time.	Local
AFD 1A Bus Over Voltage	Circuit	Immediate	NonLatch	Holding, Running	Bus overvoltage indicated the high bus voltage cut out has been exceeded while the AFD is in a non-stopped mode. The drive shall automatically clear this diagnostic if the dc bus voltage returns to normal range within 15s.	Local
AFD 2A Bus Over Voltage	Circuit	Immediate	NonLatch	Holding, Running	Bus overvoltage indicated the high bus voltage cut out has been exceeded while the AFD is in a non-stopped mode. The drive shall automatically clear this diagnostic if the dc bus voltage returns to normal range within 15s.	Local
AFD 1A Loss Of Motor Control	Circuit	Immediate	NonLatch	All	AFD generated faults that can occur due to external power anomalies or abnormal motor loading that require ability to auto reset. This diagnostic maps to the occurrence of AFD generated faults of: Hardware Over Current, Over Speed Limit, IPM Over Current, Drive Powerup, IPM and Speed Estimate Error.	Local
AFD 2A Loss Of Motor Control	Circuit	Immediate	NonLatch	All	AFD generated faults that can occur due to external power anomalies or abnormal motor loading that could be a transient or temporary condition. This diagnostic maps to the occurrence of AFD generated faults of: Hardware Over Current, Over Speed Limit, IPM Over Current, Drive Powerup, IPM and Speed Estimate Error.	Local
AFD 1A Motor Fault	Circuit	Immediate	Latch	All	AFD generated faults that imply internal failures. This diagnostic maps to the occurrence of AFD generated faults of: Motor Overload, Load Loss, and Output Phase Loss. Check output wiring and motor health.	Local
AFD 2A Motor Fault	Circuit	Immediate	Latch	All	AFD generated faults that imply internal failures. This diagnostic maps to the occurrence of AFD generated faults of: Motor Overload, Load Loss, and Output Phase Loss. Check output wiring and motor health.	Local
AFD 1A Over Temperature	Circuit	Immediate	Latch	All	Heatsink Over Temperature (185°F/85°C), Transistor Over Temperature (320°F/160°C) or Control Board Over Temperature. Check drive liquid or air cooling.	Local
AFD 2A Over Temperature	Circuit	Immediate	Latch	All	Heatsink Over Temperature (185°F/85°C), Transistor Over Temperature (320°F/160°C) or Control Board Over Temperature. Check drive liquid or air cooling.	Local
AFD 1A Motor Current Overload	Circuit	Immediate (decel)	Latch	Running	Software Filtered Overcurrent has been detected. Can be loss of control of motor, or hardware failure.	Local
AFD 2A Motor Current Overload	Circuit	Immediate (decel)	Latch	Running	Software Filtered Overcurrent has been detected. Can be loss of control of motor, or hardware failure.	Local

**Table 29. Diagnostics – AFD (continued)**

<b>Diagnostic Name and Source</b>	<b>Affects Target</b>	<b>Severity</b>	<b>Persistence</b>	<b>Active Modes [Inactive Modes]</b>	<b>Criteria</b>	<b>Reset Level</b>
AFD 1A Customized Protection Fault	Circuit	Immediate	Latch <sup>(a)</sup>	All	One of drive custom protections has occurred (Pump-Out Failed, Low Rotor Flux Feedback, or Bump Failure) OR drive custom protections not enabled or programmed. Contact Trane Service. <sup>(a)</sup>	Local
AFD 2A Customized Protection Fault	Circuit	Immediate	Latch <sup>(a)</sup>	All	One of drive custom protections has occurred (Pump-Out Failed, Low Rotor Flux Feedback, or Bump Failure) OR drive custom protections not enabled or programmed. Contact Trane Service. <sup>(a)</sup>	Local
AFD 1A Ground Fault	Circuit	Immediate	Latch	All	Measured ground current exceeds ground current sensitivity. Read drive fault value over Tracer® TU and refer to drive programming manual to determine which output leg and transistors are indicated.	Local
AFD 2A Ground Fault	Circuit	Immediate	Latch	All	Measured ground current exceeds ground current sensitivity. Read drive fault value over Tracer® TU and refer to drive programming manual to determine which output leg and transistors are indicated.	Local
AFD 1A Motor Shorted	Circuit	Immediate	Latch	All	Motor or power stage is shorted line-to-line. Read drive fault value over Tracer® TU and refer to drive programming manual to determine which phases are indicated.	Local
AFD 2A Motor Shorted	Circuit	Immediate	Latch	All	Motor or power stage is shorted line-to-line. Read drive fault value over Tracer® TU and refer to drive programming manual to determine which phases are indicated.	Local
AFD 1A Comm Loss: Main Processor	Circuit	Immediate (decel)	Latch	All	The AFD detected a continual loss of communication with the main processor for greater than 10s.	Local
AFD 1A Comm Loss: Main Processor	Circuit	Immediate (decel)	Latch	All	The AFD detected a continual loss of communication with the main processor for greater than 10s.	Local
AFD 1A Precharge Fault	Circuit	Immediate	Latch	All	The drives internal precharge was commanded to open while the drive was running. This can occur if the DC bus drops to a low level.	Local
AFD 2A Precharge Fault	Circuit	Immediate	Latch	All	The drives internal precharge was commanded to open while the drive was running. This can occur if the DC bus drops to a low level.	Local
AFD 1A General Failure	Circuit	Immediate (decel)	Latch	All	Drive fault other than those supported in this list. Read drive fault value over Tracer TU and refer to drive programming manual.	Local
AFD 2A General Failure	Circuit	Immediate (decel)	Latch	All	Drive fault other than those supported in this list. Read drive fault value over Tracer TU and refer to drive programming manual.	Local
AFD 1A Gate Kill Active	Circuit	Immediate	NonLatch	All	The respective drive's gate-kill circuitry was activated (open circuit). The respective compressor's High Pressure Cutout Switch is wired into this circuit, and will cause an immediate shutdown of the drive and compressor in the event of an HPC trip. A 2nd separate HPC diagnostic will occur in conjunction with this diagnostic – see details of the Main Processor Diagnostic "High Pressure Cutout" below (that is latching).	Local

**Table 29. Diagnostics – AFD (continued)**

Diagnostic Name and Source	Affects Target	Severity	Persistence	Active Modes [Inactive Modes]	Criteria	Reset Level
AFD 2A Gate Kill Active	Circuit	Immediate	NonLatch	All	The respective drive's gate-kill circuitry was activated (open circuit). The respective compressor's High Pressure Cutout Switch is wired into this circuit, and will cause an immediate shutdown of the drive and compressor in the event of an HPC trip. A 2nd separate HPC diagnostic will occur in conjunction with this diagnostic – see details of the Main Processor Diagnostic "High Pressure Cutout" below (that is latching).	Local
AFD 1A Input Transformer or Filter High Temp	Circuit	Immediate Shutdown	Latch	All	The AFD is tripped by Input Transformer or Filter High Temperature Cutout.	Local
AFD 2A Input Transformer or Filter High Temp	Circuit	Immediate Shutdown	Latch	All	The AFD is tripped by Input Transformer or Filter High Temperature Cutout.	Local
AFD 1A Low Rotor Flux Feedback	Circuit	Immediate (decel)	Latch	Running	The estimated rotor flux dropped below the minimum threshold. Suspect motor demagnetization.	Local
AFD 2A Low Rotor Flux Feedback	Circuit	Immediate (decel)	Latch	Running	The estimated rotor flux dropped below the minimum threshold. Suspect motor demagnetization.	Local

## Main Processor Diagnostics

**Table 30. Diagnostics – main processor**

Diagnostic Name	Affects Target	Severity	Persistence	Active Modes [Inactive Modes]	Criteria	Reset Level
Drive Cooling Temp Sensor – Ckt2	Circuit	Normal	Latch	All	Bad Sensor or LLID.	Remote
BAS Communication Lost	None	Special Action	NonLatch	All	The BAS was setup as "installed" at the MP and the Lontalk LCIC lost communications with the BAS for 15 contiguous minutes after it had been established. Refer to Section on Setpoint Arbitration to determine how setpoints and operating modes may be affected by the comm loss. The chiller follows the value of the Tracer Default Run Command which can be previously written by Tracer and stored nonvolatily by the MP (either use local or shutdown). Note that this diagnostic is never operational for BacNet Communication interface (BCIC) and only operational with a LonTalk Communication interface (LCIC) if so configured by the BAS or Tracer system.	Remote
BAS Failed to Establish Communication	None	Special Action	NonLatch	At power-up	The BAS was setup as "installed" and the BAS did not communicate with the Lontalk LCIC within 15 minutes after chiller controls power-up. Refer to Section on Setpoint Arbitration to determine how setpoints and operating modes may be effected. Note that this diagnostic is never operational for BacNet Communication interface (BCIC) and only operational with a LonTalk Communication interface (LCIC) if so configured by the BAS or Tracer system.	Remote



**Table 30. Diagnostics – main processor (continued)**

Diagnostic Name	Affects Target	Severity	Persistence	Active Modes [Inactive Modes]	Criteria	Reset Level
Check Clock	Chiller	Info	Latch	All	The real time clock had detected loss of its oscillator at some time in the past. Check / replace battery This diagnostic can be effectively cleared only by writing a new value to the chiller's time clock using the TU's "set chiller time" functions.	Remote
Condenser Fan Inverter Fault - Ckt1	None	Info	NonLatch	All	A fault signal has been detected from at least one of the Variable Speed Inverter Drive Condenser Fans of Circuit 1 (including the right hand fan of the Shared Fan Module if present). No action is taken.	Remote
Condenser Fan Inverter Fault - Ckt2	None	Info	NonLatch	All	A fault signal has been detected from at least one of the Variable Speed Inverter Drive Condenser Fans of Circuit 2 (including the left hand fan of the Shared Fan Module if present). No action is taken	Remote
Condenser Rfgt Pressure Transducer - Ckt1	Circuit	Immediate	Latch	All	Bad Sensor or LLID	Remote
Condenser Rfgt Pressure Transducer - Ckt2	Circuit	Immediate	Latch	All	Bad Sensor or LLID	Remote
Discharge Rfgt Temp Sensor – Cprsr1A	Circuit	Immediate	Latch	All	Bad Sensor or LLID	Remote
Discharge Rfgt Temp Sensor – Cprsr2A	Circuit	Immediate	Latch	All	Bad Sensor or LLID	Remote
Drive Cooling Supply Temp Sensor – Ckt1	Circuit	Normal	Latch	All	Bad Sensor or LLID.	Remote
Emergency Stop	Chiller	Immediate	Latch	All	EMERGENCY STOP input is open. An external interlock has tripped. Time to trip from input opening to unit stop shall be 0.1 to 1.0 seconds	Local
Evap Rfgt Pool Temp Sensor – Ckt1	Circuit and Chiller	Special Action and Info	NonLatch	All	Bad Sensor or LLID. Note: The Evap Pool Temp Sensors are used for evaporator freeze protection (running and non-running)	Remote
Evap Rfgt Pool Temp Sensor – Ckt2	Circuit and Chiller	Special Action and Info	NonLatch	All	Bad Sensor or LLID. Note: The Evap Pool Temp Sensors are used for evaporator freeze protection (running and non-running)	Remote
Evap Rfgt Pool Temp Sensor Error – Ckt1	Circuit	Info and Special Action	Latch	Ckt Energized [Ckt Not Energized]	The evaporator refrigerant pool temperature sensor is indicating a temperature significantly warmer than the evaporator entering water temperature (by more than 7.2°F for 5 continuous min excluding ckt nonoperation and a 2 min ignore time relative to ckt startup). While this diagnostic is active, it will invalidate the evaporator pool temperature sensor. Freeze protection functions (i.e. freeze diagnostics and Evap Pump Override) will default to the respective evaporator pressure transducer and its calculated saturation temperature	Local

**Diagnostics**
**Table 30. Diagnostics – main processor (continued)**

Diagnostic Name	Affects Target	Severity	Persistence	Active Modes [Inactive Modes]	Criteria	Reset Level
Evap Rfgt Pool Temp Sensor Error – Ckt2	Circuit	Info and Special Action	Latch	Ckt Energized [Ckt Not Energized]	The evaporator refrigerant pool temperature sensor is indicating a temperature significantly warmer than the evaporator entering water temperature (by more than 7.2°F for 5 continuous min excluding ckt nonoperation and a 2 min ignore time relative to ckt startup). While this diagnostic is active, it will invalidate the evaporator pool temperature sensor. Freeze protection functions (i.e. freeze diagnostics and Evap Pump Override) will default to the respective evaporator pressure transducer and its calculated saturation temperature	Local
Evap Spillover Liquid Level Sensor – Ckt1	Circuit	Normal	Latch	All	Bad Sensor or LLID	Remote
Evap Spillover Liquid Level Sensor – Ckt2	Circuit	Normal	Latch	All	Bad Sensor or LLID	Remote
Evap Water Flow (Entering Water Temp)	None	Info	NonLatch	Any Ckt Energized [ No Ckts Energized]	The entering evaporator water temp fell below the leaving evaporator water temp by more than 2°F for 180 °F-sec, minimum trip time 30 seconds. It can warn of improper flow direction through the evaporator, misbound water temperature sensors, improper sensor installation, partially failed sensors, or other system problems. Note that either entering or leaving water temp sensor or the water system could be at fault	Remote
Evaporator Approach Error – Ckt1	Circuit	Immediate	Latch	Respective circuit running	The Evaporator approach temperature for the respective circuit (ELWT – Evap Sat Temp Ckt 1) is negative by more than 10°F for 1 minute continuously while the circuit / compressor is operating. Either the Evap Leaving Water Temp sensor, or Evap Suction Rfgt Pressure Transducer Ckt 1 is in error	Remote
Evaporator Approach Error – Ckt2	Circuit	Immediate	Latch	Respective circuit running	The Evaporator approach temperature for the respective circuit (ELWT – Evap Sat Temp Ckt 2) is negative by more than 10°F for 1 minute continuously while the circuit / compressor is operating. Either the Evap Leaving Water Temp sensor, or Evap Suction Rfgt Pressure Transducer Ckt 2 is in error	Remote
Evaporator Entering Water Temp Sensor	Chiller	Normal	Latch	All	Bad Sensor or LLID. Note: Entering Water Temp Sensor is used in EXV pressure control as well as ice making so it must cause a unit shutdown even if ice or CHW reset is not installed	Remote
Evaporator Leaving Water Temp Sensor	Chiller	Normal	Latch	All	Bad Sensor or LLID	Remote
Evaporator Water Flow Lost	Chiller	Immediate	NonLatch	[All Stop modes]	a. The Evaporator water flow switch input was open for more than 6 contiguous seconds (or 15 seconds for thermal dispersion type flow switch). b. This diagnostic does not de-energize the evap pump output. c. 6 seconds of contiguous flow shall clear this diagnostic	Remote

**Table 30. Diagnostics – main processor (continued)**

Diagnostic Name	Affects Target	Severity	Persistence	Active Modes [Inactive Modes]	Criteria	Reset Level
Evaporator Water Flow Overdue	Chiller	Normal	NonLatch	Estab. Evap. Water Flow on going from STOP to AUTO or Evap Pump Override.	Evaporator water flow was not proven within 20 minutes of the Evaporator water pump relay being energized in normal "Stop" to "Auto" transition. If the pump is overridden to "On" for certain diagnostics, the delay on diagnostic callout shall be only 255 seconds. The pump command status will not be affected by this diagnostic in either case	Remote
Excessive Condenser Pressure - Ckt1	Circuit	Immediate	Latch	All	The condenser pressure transducer of this circuit has detected a condensing pressure in excess of the design high side pressure as limited by the particular compressor type	Remote
Excessive Condenser Pressure - Ckt2	Circuit	Immediate	Latch	All	The condenser pressure transducer of this circuit has detected a condensing pressure in excess of the design high side pressure as limited by the particular compressor type	Remote
External Chilled/Hot Water Setpoint	None	Info	Latch	All	a. Function Not "Enabled": no diagnostics. b. "Enabled ": Out-Of-Range Low or Hi or bad LLID, set diagnostic, default CWS to next level of priority (e.g. Front Panel SetPoint)	Remote
External Demand Limit Setpoint	None	Info	Latch	All	a. Not "Enabled": no diagnostics. b. "Enabled ": Out-Of-Range Low or Hi or bad LLID, set diagnostic, default CLS to next level of priority (e.g. Front Panel SetPoint)	Remote
Failure to Arm or Hold - AFD 1A	Circuit	Info	Nonlatch	All	AFD 1A (controlling Compressor 1A) failed to respond in an appropriate time with its status of Armed to Hold or Hold within the allotted time of 1 minute of the sent command. (Arm to Hold command sent; armed to Hold status received; Hold command sent; Hold status received)	Local
Failure to Arm or Hold - AFD 2A	Circuit	Info	Nonlatch	All	AFD 2A (controlling Compressor 2A) failed to respond in an appropriate time with its status of Armed to Hold or Hold within the allotted time of 1 minute of the sent command. (Arm to Hold command sent; armed to Hold status received; Hold command sent; Hold status received)	Local
Failure to Arm or Start - AFD 1A	Circuit	Immediate	Latch	All	AFD 1A (controlling Compressor 1A) failed to arm or start within the allotted time of 1 minute. (Arm to Start command sent; armed to Start status received; Start command sent; Started status received)	Local
Failure to Arm or Start - AFD 2A	Circuit	Immediate	Latch	All	AFD 2A (controlling Compressor 2A) failed to arm or start within the allotted time of 1 minute. (Arm to Start command sent; armed to Start status received; Start command sent; Started status received)	Local
High Differential Rfght Pressure - Ckt1	Circuit	Normal	Latch	Cprsr Energized [Service/Op Pumpdown]	The differential pressure for the respective circuit was above 275 Psid (1890 kPa) for 2 consecutive samples 5 seconds apart	Remote
High Differential Rfght Pressure - Ckt2	Circuit	Normal	Latch	Cprsr Energized [Service/Op Pumpdown]	The differential pressure for the respective circuit was above 275 Psid (1890 kPa) for 2 consecutive samples 5 seconds apart	Remote

**Diagnostics**
**Table 30. Diagnostics – main processor (continued)**

Diagnostic Name	Affects Target	Severity	Persistence	Active Modes [Inactive Modes]	Criteria	Reset Level
High Discharge Temperature – Cprsr1A	Circuit	Immediate	Latch	All [compressor run unload or compressor not running]	The compressor discharge temperature exceeded 200°F (without oil cooler) or 230°F (with oil cooler). This diagnostic will be suppressed during Stopping mode or after the compressor has stopped. Note: As part of the Compressor High Temperature Limit Mode (aka Minimum Capacity Limit), the compressor shall be forced loaded as the filtered discharge temperature reaches 190°F (without oil coolers), or 220°F (with oil coolers)	Remote
High Discharge Temperature – Cprsr2A	Circuit	Immediate	Latch	All [compressor run unload or compressor not running]	The compressor discharge temperature exceeded 200°F (without oil cooler) or 230°F (with oil cooler). This diagnostic will be suppressed during Stopping Mode or after the compressor has stopped. Note: As part of the Compressor High Temperature Limit Mode (aka Minimum Capacity Limit), the compressor shall be forced loaded as the filtered discharge temperature reaches 190°F (without oil coolers), or 220°F (with oil coolers)	Remote
High Evaporator Refrigerant Pressure	Chiller	Immediate	NonLatch	All	The evaporator refrigerant pressure of either circuit has risen above 190 psig. The evaporator water pump relay will be de-energized to stop the pump regardless of why the pump is running. The diagnostic will auto reset and the pump will return to normal control when all of the evaporator pressures fall below 185 psig. The primary purpose is to stop the evaporator water pump and its associated pump heat from causing refrigerant side pressures, close to the evaporator relief valve setting, when the chiller is not running, such as could occur with Evap Water Flow Overdue or Evaporator Water Flow Loss Diagnostics	Remote
High Evaporator Water Temperature	Chiller	Info and Special Action	NonLatch	Only effective if either 1)Evap Wtr Flow Overdue, 2) Evap Wtr Flow Loss, or 3)Low Evap Rfgr Temp,-Unit Off, diagnostic is active.	Either the leaving or the entering water temperature exceeded the high evap water temp limit (TV service menu settable –default 105F) for 15 continuous seconds. The evaporator water pump relay will be de-energized to stop the pump but only if it is running due one of the diagnostics listed on the left . The diagnostic will auto reset and the pump will return to normal control when both the entering and leaving temperatures fall 5°F below the trip setting. The primary purpose is to stop the evaporator water pump and its associated pump heat from causing excessive waterside temperatures and waterside pressures when the chiller is not running but the evap pump is on due to either Evap Water Flow Overdue, Evaporator Water Flow Loss , or Low Evap Temp – Unit Off Diagnostics. This diagnostic will not auto clear solely due to the clearing of the enabling diagnostic	Remote
High Motor Winding Temperature - Cprsr1A	Circuit	Immediate	Latch	All	Any of the compressor’s motor winding temperature sensors is seen to be beyond the windings rated temperature of 265°F (129.4°C)	Local
High Motor Winding Temperature - Cprsr2A	Circuit	Immediate	Latch	All	Any of the respective compressor’s motor winding temperature sensors is seen to be beyond the windings rated temperature of 265°F (129.4°C)	Local
High Pressure Cutout - Cprsr1A	Circuit	Immediate	Latch	All	A high pressure cutout was detected by AFD 1A Gate Kill Input ; trip at 315 ± 5 PSIG	Local

**Table 30. Diagnostics – main processor (continued)**

Diagnostic Name	Affects Target	Severity	Persistence	Active Modes [Inactive Modes]	Criteria	Reset Level
High Pressure Cutout - Cprsr2A	Circuit	Immediate	Latch	All	A high pressure cutout was detected by AFD 2A Gate Kill Input ; trip at 315 ± 5 PSIG	Local
High Refrigerant Pressure Ratio - Ckt1	Circuit	Immediate	Latch	Cprsr Energized	The pressure ratio for the respective circuit exceeded 12.3 for 1 contiguous minute while running in any mode. The pressure ratio is defined as Pcond (abs)/Pevap(abs)	Remote
High Refrigerant Pressure Ratio - Ckt2	Circuit	Immediate	Latch	Cprsr Energized	The pressure ratio for the respective circuit exceeded 12.3 for 1 contiguous minute while running in any mode. The pressure ratio is defined as Pcond (abs)/Pevap(abs)	Remote
Interrupt Failure - AFD1A	Circuit	Immediate Shutdown and Special Action	Latch	AFD intended to be OFF	Respective AFD is reporting that it is still running the compressor when the MP has commanded the drive/compressor to be Off. Detection time shall be 10 seconds minimum and 15 seconds maximum. With build rev 2.13 and later: 22 sec min, 27sec max. On detection and until the controller is manually reset: this diagnostic shall be active and the alarm relay shall be energized, the Evap Pump Output will be energized, the effected compressor will be continually commanded off, and be unloaded. For as long as compressor operation continues, the MP shall continue liquid level, oil return, and fan control on the circuit effected.	Local
Interrupt Failure - AFD2A	Circuit	Immediate Shutdown and Special Action	Latch	AFD intended to be OFF	Respective AFD is reporting that it is still running the compressor when the MP has commanded the drive/compressor to be Off. Detection time shall be 10 seconds minimum and 15 seconds maximum. With build rev 2.13 and later: 22 sec min, 27sec max. On detection and until the controller is manually reset: this diagnostic shall be active and the alarm relay shall be energized, the Evap Pump Output will be energized, the effected compressor will be continually commanded off, and be unloaded. For as long as compressor operation continues, the MP shall continue liquid level, oil return, and fan control on the circuit effected.	Local
LCI-C Software Mismatch: Use BAS Tool	Chiller	Info	Nonlatch	All	The neuron software in the LCI-C module does not match the chiller type. Download the proper software into the LCI-C neuron. To do this, use the Rover service tool, or a LonTalk® tool capable of downloading software to a Neuron 3150®	Remote
Loss of Oil (Running) - Cprsr1A	Circuit	Immediate	Latch	Starter Contactor Energized	In running modes , Oil Loss Level Sensor detects lack of oil in the oil sump feeding the compressor (distinguishing a liquid flow from a vapor flow)	Local
Loss of Oil (Running) - Cprsr2A	Circuit	Immediate	Latch	Starter Contactor Energized	In running modes , Oil Loss Level Sensor detects lack of oil in the oil sump feeding the compressor (distinguishing a liquid flow from a vapor flow)	Local
Loss of Oil (Stopped) - Cprsr1A	Circuit	Immediate Shutdown and Special Action	Latch	Compressor Pre-start [all other modes]	Oil Loss Level! Sensor detects a lack of oil in the oil sump feeding the compressor for 90 seconds after EXV preposition is completed on an attempted circuit start. Note: Compressor start is delayed pending oil detection during that time, but not allowed once the diagnostic occurs	Local
Loss of Oil (Stopped) - Cprsr2A	Circuit	Immediate Shutdown and Special Action	Latch	Compressor Pre-start [all other modes]	Oil Loss Level! Sensor detects a lack of oil in the oil sump feeding the compressor for 90 seconds after EXV preposition is completed on an attempted circuit start. Note: Compressor start is delayed pending oil detection during that time, but not allowed once the diagnostic occurs	Local

**Table 30. Diagnostics – main processor (continued)**

Diagnostic Name	Affects Target	Severity	Persistence	Active Modes [Inactive Modes]	Criteria	Reset Level
Low Differential Rfght Pressure - Ckt1	Circuit	Immediate	Latch	Cprsr Energized	The system differential pressure (Pc-Pe) for the respective circuit was below 15 psid (240.5 kPa) or the pressure ratio (Pc/Pe) was less than 1.1 while the compressor is running for a period of time dependent on the deficit (15 sec ignore time from circuit start) Refer to the Oil Flow Protection specification for the time to trip function.	Remote
Low Differential Rfght Pressure - Ckt2	Circuit	Immediate	Latch	Cprsr Energized	The system differential pressure (Pc-Pe) for the respective circuit was below 15psid (240.5 kPa) or the pressure ratio (Pc/Pe) was less than 1.1 while the compressor is running for a period of time dependent on the deficit (15 sec ignore time from circuit start) Refer to the Oil Flow Protection specification for the time to trip function.	Remote
Low Discharge Superheat - Ckt1	Circuit	Normal	Latch	Any Running Mode	While Running Normally, the Discharge Superheat was less than 9 degrees F for more than 4878 degree F seconds. At circuit startup, the Discharge Superheat will be ignored for 5 minutes	Remote
Low Discharge Superheat - Ckt2	Circuit	Normal	Latch	Any Running Mode	While Running Normally, the Discharge Superheat was less than 9 degrees F for more than 4878 degree F seconds. At circuit startup, the Discharge Superheat will be ignored for 5 minutes	Remote
Low Drive Cooling Supply Temp - Ckt1	Circuit	Info	NonLatch	All Ckt Running Modes	The Drive Cooling Supply temperature for the respective circuit is seen to be more than 5F cooler than its setpoint for more than 30 minutes. Auto-reset if temperatures return to Undesirable condensation is possible on the cooled surfaces inside the control panel. Inspect the Drive Cooling System components for misoperation or failure	
Low Drive Cooling Supply Temp - Ckt2	Circuit	Info	NonLatch	All Ckt Running Modes	The Drive Cooling Supply Temperature for the respective circuit is seen to be more than 5F cooler than its setpoint for more than 30 minutes. Undesirable condensation is possible on the cooled surfaces inside the control panel. Inspect the Drive Cooling System components for misoperation or failure	
Low Evaporator Rfght Pressure - Ckt1	Circuit	Immediate	Latch	Cprsr Prestart and Cprsr Energized	a. The Evap Refrig Pressure dropped below 10 Psia just prior to compressor start (after EXV preposition). b. During Early Startup Period: the Evap Refrig Pressure fell below a pressure equal to Condenser Pressure ÷ 8 but as limited to not less than 6 or greater than 10 psia. c. After Early Startup Period expires: The Evap Refrig Pressure fell below 16 Psia for 30 seconds or below 10 psia for 5 seconds. (Note: the Early Startup Period for RTAE it is between 1 and 5 min as an inverse function of the Cond Temp measured at time of circuit startup)	Local

**Table 30. Diagnostics – main processor (continued)**

Diagnostic Name	Affects Target	Severity	Persistence	Active Modes [Inactive Modes]	Criteria	Reset Level
Low Evaporator Rfght Pressure - Ckt2	Circuit	Immediate	Latch	Cprsr Prestart and Cprsr Energized	a. The Evap Refrig Pressure dropped below 10 Psia just prior to compressor start (after EXV preposition). b. During Early Startup Period: the Evap Refrig Pressure fell below a pressure equal to Condenser Pressure ÷ 8 but as limited to not less than 6 or greater than 10 psia. c. After Early Startup Period expires: The Evap Refrig Pressure fell below 16 Psia for 30 seconds or below 10 psia for 5 seconds. (Note: the Early Startup Period for RTAE it is between 1 and 5 min as an inverse function of the Cond Temp measured at time of circuit startup)	Local
Low Evaporator Rfght Temperature - Ckt1	Circuit	Immediate	Latch	All Ckt Running Modes [Service Pumpdown]	The warmer of either the Evaporator Refrigerant Pool Temperature or the Evaporator Saturated Temperature for the respective circuit, dropped below the Low Refrigerant Temperature Cutout Setpoint for 2250°F-sec (12°F-sec/sec max rate for early circuit startup period) while the circuit was running. The minimum LERTC setpoint is -5°F the point at which oil separates from the refrigerant. The integral is held nonvolatily though power down, is continuously calculated, and can decay or build during the circuit's off cycle as conditions warrant	Remote
Low Evaporator Rfght Temperature - Ckt2	Circuit	Immediate	Latch	All Ckt Running Modes [Service Pumpdown]	The warmer of either the Evaporator Refrigerant Pool Temperature or the Evaporator Saturated Temperature for the respective circuit, dropped below the Low Refrigerant Temperature Cutout Setpoint for 2250°F-sec (12°F-sec/sec max rate for early circuit startup period) while the circuit was running. The minimum LERTC setpoint is -5°F the point at which oil separates from the refrigerant. The integral is held nonvolatily though power down, is continuously calculated, and can decay or build during the circuit's off cycle as conditions warrant.	Remote
Low Evaporator Temp (Unit Off) - Ckt1	Evap Pump	Info and Special Action	NonLatch	Unit in Stop Mode, or in Auto Mode and No Ckt's Energzd [Any Ckt Energzd]	The respective circuit's "Chiller Off Cycle Freeze Protection Integral" was seen to be higher than ½ of its trip value while the chiller is in the Stop mode, or in Auto mode with no compressors running, for one minute and more. The COCFP integral is increased if the Average of the Evap Water Temperature and the Evap Refrigerant Pool Temp is below the value of the Low Evap Rfght Temp Cutout + 4°F. Energize Evap Water Pump and Off-Cycle Freeze Avoidance Request Relay until diagnostic auto resets, then return to normal evap pump control and de-energize the Freeze Avoidance Request. Automatic reset occurs when the respective Evap Rfght Pool Temp rises 2°F (1.1°C) above the LERTC cutout setting and the COCFP Integral is less than 1/3 of its trip value. This diagnostic even while active, does not prevent operation of either circuit. (At each circuit shutdown, the COCFP integral is initialized to the LERTC integral)	Remote

**Table 30. Diagnostics – main processor (continued)**

Diagnostic Name	Affects Target	Severity	Persistence	Active Modes [Inactive Modes]	Criteria	Reset Level
Low Evaporator Temp (Unit Off) – Ckt2	Evap Pump	Special Action	NonLatch	Unit in Stop Mode, or in Auto Mode and No Ckt's Energzd [Any Ckt Energzd]	The respective circuit's "Chiller Off Cycle Freeze Protection Integral" was seen to be higher than ½ of its trip value while the chiller is in the Stop mode, or in Auto mode with no compressors running, for one minute and more. The COCFP integral is increased if the Average of the Evap Water Temperatures and the Evap Refrigerant Pool Temp is below the value of the Low Evap Rfgt Temp Cutout + 4°F. Energize Evap Water Pump and Off-Cycle Freeze Avoidance Request Relay until diagnostic auto resets, then return to normal evap pump control and de-energize the Freeze Avoidance Request. Automatic reset occurs when the respective Evap Rfgt Pool Temp rises 2°F (1.1°C) above the LERTC cutout setting AND the COCFP Integral is less than 1/3 of its trip value. This diagnostic even while active, does not prevent operation of either circuit. (At each circuit shutdown, the COCFP integral is initialized to the LERTC integral)	Remote
Low Evaporator Water Temp (Unit Off)	Evap Pump and Freeze Avoidance Request Relay	Info and Special Action	NonLatch	Unit in Stop Mode, or in Auto Mode and No Ckt(s) Energzd [Any Ckt Energzd]	Either the entering or leaving evaporator water temp fell below the leaving water temp cutout setting for 30 °F-seconds while the Chiller is in the Stop mode, or in Auto mode with no compressors running. Energize Freeze Avoidance Request Relay and Evap Water Pump Relay until diagnostic auto resets, then de-energize the Freeze Avoidance Request Relay and return to normal evap pump control. Automatic reset occurs when both temps rise 2°F (1.1°C) above the cutout setting for 5 minutes, or either circuit starts. This diagnostic even while active, does not prevent operation of either circuit	Remote
Low Evaporator Water Temp: Unit On	Chiller	Immediate Shutdown and Special Action	NonLatch	Any Ckt[s] Energzd [No Ckt(s) Energzd]	The evaporator entering or leaving water temp fell below the cutout setpoint for 30° F-seconds while the compressor was running. Automatic reset occurs when both of the temperature rises 2 °F (1.1°C) above the cutout setting for 2 minutes. This diagnostic shall not de-energize the Evaporator Water Pump Output	Remote
Low Oil Flow - Cprsr 1A	Circuit	Immediate	Latch	Cprsr Energized and Delta P above 15 Psid	The oil pressure transducer for this compressor was indicating an unacceptable oil pressure drop as a % of the available oil pressure to move oil, suggesting significantly reduced oil flow to the compressor. Possible root causes include oil line service valve closed or restricted, dirty or restricted oil filter, or compressor oil line kepner valve malfunction	Local
Low Oil Flow - Cprsr2A	Circuit	Immediate	Latch	Cprsr Energized and Delta P above 15 Psid	The oil pressure transducer for this compressor was indicating an unacceptable oil pressure drop as a % of the available oil pressure to move oil, suggesting significantly reduced oil flow to the compressor. Possible root causes include oil line service valve closed or restricted, dirty or restricted oil filter, or compressor oil line kepner valve malfunction	Local



**Table 30. Diagnostics – main processor (continued)**

Diagnostic Name	Affects Target	Severity	Persistence	Active Modes [Inactive Modes]	Criteria	Reset Level
Low Oil Return or AFD Cooling – Ckt1	Circuit	Info	NonLatch	All Ckt Running Modes	The evaporator’s spillover tank refrigerant liquid level, which feeds the oil return and drive cooling heat exchanger, is seen to be less than 90% of its min level for 20 continuous minutes – reset when level gets to 88% of min level. The occurrence of this warning in conjunction with the “Loss of Oil (Running)” or any of the “AFD Over Temp” shutdown diagnostics, suggests either EXV problems or loss of charge is a contributing factor	
Low Oil Return or AFD Cooling – Ckt2	Circuit	Info	NonLatch	All Ckt Running Modes	The evaporator’s spillover tank refrigerant liquid level, which feeds the oil return and drive cooling heat exchanger, is seen to be less than 90% of its min level for 20 continuous minutes – reset when level gets to 88% of min level. The occurrence of this warning in conjunction with the “Loss of Oil (Running)” or any of the “AFD Over Temperature” shutdown diagnostics, suggests either EXV problems or loss of charge is a contributing factor	
Motor Winding Temp Sensor - Cprsr1A	Circuit	Info or None	Latch	All	Both of the motor winding temperature sensors are seen to be out of their normal range. (Severity is adjustable via TU Service Tool – default is Info)	Local
Motor Winding Temp Sensor- Cprsr2A	Circuit	Info or None	Latch	All	Both of the motor winding temperature sensors are seen to be out of their normal range. (Severity is adjustable via TU Service Tool – default is Info)	Local
MP Application Memory CRC Error	Chiller	Immediate	Latch	All Modes	Memory error criteria TBD	Remote
MP: Could not Store Starts and Hours	None	Info	Latch	All	MP has determined there was an error with the previous power down store. Starts and Hours may have been lost for the last 24 hours	Remote
MP: Invalid Configuration	None	Immediate	Latch	All	MP has an invalid configuration based on the current software installed	Remote
MP: Non-Volatile Memory Reformat	None	Info	Latch	All	MP has determined there was an error in a sector of the Non-Volatile memory and it was reformatted. Check settings	Remote
MP: Reset Has Occurred	None	Info	NonLatch	All	The main processor has successfully come out of a reset and built its application. A reset may have been due to a power up, or a power loss of a minimum or longer duration to cause an MP power down reset, or when installing new software or defining a new configuration. This diagnostic is immediately and automatically cleared and thus can only be seen in the Historic Diagnostic List in TU	Remote
No Differential Rfgr Pressure – Ckt1	Circuit	Immediate	Latch	Compressor running on Circuit	The system differential pressure was below 7.7 Psid (53 kPa) for 6 seconds after the 11 seconds ignore time relative to cprsr/circuit startup had expired	Remote
No Differential Rfgr Pressure – Ckt2	Circuit	Immediate	Latch	Compressor running on Circuit	The system differential pressure was below 7.7 Psid (53 kPa) for 6 seconds after the 11 seconds ignore time relative to cprsr/circuit startup had expired	Remote

**Diagnostics**
**Table 30. Diagnostics – main processor (continued)**

Diagnostic Name	Affects Target	Severity	Persistence	Active Modes [Inactive Modes]	Criteria	Reset Level
Oil Analysis Recommended – Ckt1	Circuit	Info	Latch	“Service Messages” enabled	Diagnostic occurs when accumulated circuit operating hours since last initialized exceeds 2000 hours. Diagnostic can be manually cleared but will reoccur every month (720 hours on real time clock) as long as accumulator is not re-initialized	Remote
Oil Analysis Recommended – Ckt2	Circuit	Info	Latch	“Service Messages” enabled	Diagnostic occurs when accumulated circuit operating hours since last initialized exceeds 2000 hours. Diagnostic can be manually cleared but will reoccur every month (720 hours on real time clock) as long as accumulator is not re-initialized	Remote
Oil Filter Change Recommended – Cprsr1A	Circuit	Info	Latch	“Service Messages” enabled	Diagnostic occurs only when “service messages” are enabled and when average oil pressure drop exceeds 18%. Diagnostic can be manually cleared but will reoccur every month (720 hours on real time clock) as long as average pressure drop does not fall below 16%	Remote
Oil Filter Change Recommended – Cprsr2A	Circuit	Info	Latch	“Service Messages” enabled	Diagnostic occurs only when “service messages” are enabled and when average oil pressure drop exceeds 18%. Diagnostic can be manually cleared but will reoccur every month (720 hours on real time clock) as long as average pressure drop does not fall below 16%	Remote
Oil Flow Protection Fault – Ck 1	Circuit	Immediate	Latch	Starter Contactor Energized [all Stop modes]	The Intermediate Oil Pressure Transducer for this cprsr is reading a pressure either above its respective circuit’s Condenser Pressure by 15 Psia or more, or below its respective Suction Pressure 10 Psia or more for 30 seconds continuously	Local
Oil Flow Protection Fault – Ckt2	Circuit	Immediate	Latch	Starter Contactor Energized [all Stop modes]	The Intermediate Oil Pressure Transducer for this cprsr is reading a pressure either above its respective circuit’s Condenser Pressure by 15 Psia or more, or below its respective Suction Pressure 10 Psia or more for 30 seconds continuously	Local
Oil Pressure Transducer – Cprsr1A	Circuit	Immediate	Latch	All	Bad Sensor or LLID	Remote
Oil Pressure Transducer – Cprsr2A	Circuit	Immediate	Latch	All	Bad Sensor or LLID	Remote
Outdoor Air Temperature Sensor	Chiller	Normal Shutdown;	Latch	All	Bad Sensor or LLID. If this diagnostic occurs, operational pumpdown will be performed regardless of the last valid temperature	Remote
Pumpdown Terminated - Ckt1	Circuit	Info	NonLatch	Service Pumpdown	Service Pumpdown cycle for this circuit was terminated abnormally due to excessive time. (RTAE max Service Pumpdown = 4 min)	Local
Pumpdown Terminated - Ckt2	Circuit	Info	NonLatch	Service Pumpdown	Service Pumpdown cycle for this circuit was terminated abnormally due to excessive. (RTAE max Service Pumpdown = 4 min)	Local
Software Error 1001: Call Trane Service	All functions	Immediate	Latch	All	A high level software watchdog has detected a condition in which there was a continuous 1 minute period of compressor operation, with neither Evaporator water flow nor a “contactor interrupt failure” diagnostic active. The presence of this software error message suggests an internal software problem has been detected. The events that led up to this failure, if known, should be recorded and transmitted to Trane Controls Engineering	Local

**Table 30. Diagnostics – main processor (continued)**

Diagnostic Name	Affects Target	Severity	Persistence	Active Modes [Inactive Modes]	Criteria	Reset Level
Software Error 1002: Call Trane Service	All functions	Immediate	Latch	All	Reported if state chart misalignment in stopped or inactive state occurred while a compressor was seen to be operating and this condition lasted for at least 1 minute (cmprsr operation due to Service Pumpdown or with Contactor Interrupt Failure diagnostic is excluded). The presence of this software error message suggests an internal software problem has been detected. The events that led up to this failure, if known, should be recorded and transmitted to Trane Controls Engineering	Local
Software Error 1003: Call Trane Service	All functions	Immediate	Latch	All	Reported if state chart misalignment occurred inferred from either Capacity Control, Circuit, or Compressor State Machines remaining in the Stopping state for more than 3 minutes. The presence of this software error message suggests an internal software problem has been detected. The events that led up to this failure, if known, should be recorded and transmitted to Trane Controls Engineering	Local
Starts or Hours Modified – Cprsr1A	None	Info	NonLatch	All	The current value for the cumulative starts and or hours for the given compressor have been modified by a write override from TU	NA
Starts or Hours Modified – Cprsr2A	None	Info	NonLatch	All	The current value for the cumulative starts and or hours for the given compressor have been modified by a write override from TU	NA
Suction Rfgr Pressure Transducer – Cprsr1A	Circuit	Immediate	Latch	All	Bad Sensor or LLID	Remote
Suction Rfgr Pressure Transducer – Cprsr2A	Circuit	Immediate	Latch	All	Bad Sensor or LLID	Remote
Unexpected Shutdown – AFD1A	Circuit	Normal	Nonlatch	All Cprsr Running modes, Starting, Running and Preparing to Shutdown	The respective AFD status reported back that it is stopped when the MP thinks it should be running and no AFD shutdown diagnostic exists. This diagnostic will be logged in the active buffer and then automatically cleared. This diagnostic could be caused by intermittent communication problems from the AFD to the MP, or due to misbinding	Remote
Unexpected Shutdown – AFD2A	Circuit	Normal	Nonlatch	All Cprsr Running modes, Starting, Running and Preparing to Shutdown	The respective AFD status reported back that it is stopped when the MP thinks it should be running and no AFD shutdown diagnostic exists. This diagnostic will be logged in the active buffer and then automatically cleared. This diagnostic could be caused by intermittent communication problems from the AFD to the MP, or due to misbinding	Remote

## Diagnostics

**Table 30. Diagnostics – main processor (continued)**

Diagnostic Name	Affects Target	Severity	Persistence	Active Modes [Inactive Modes]	Criteria	Reset Level
Very Low Evaporator Rfgrt Pressure – Ckt1	Chiller	Immediate	Latch	All	The respective circuit's evaporator pressure dropped below 80% of the current Low Evap Refrig Press Cutout setting (see above) or 8 psia, whichever is less, regardless of the running state of the circuit's compressor. Note: Unlike previous products, even if the circuit associated with the suction pressure transducer is locked out, it will not defeat the protection afforded by this diagnostic	Local
Very Low Evaporator Rfgrt Pressure – Ckt2	Chiller	Immediate	Latch	All	The respective circuit's evaporator pressure dropped below 80% of the current Low Evap Refrig Press Cutout setting (see above) or 8 psia, whichever is less, regardless of the running state of the circuit's compressor. Note: Unlike previous products, even if the circuit associated with the suction pressure transducer is locked out, it will not defeat the protection afforded by this diagnostic	Local

## Communication Diagnostics

**Notes:**

1. *The following communication loss diagnostics will not occur unless that input or output is required to be present by the particular configuration and installed options for the chiller.*
2. *Communication diagnostics (with the exception of "Excessive Loss of Comm") are named by the Functional Name of the input or output that is no longer being heard from by the Main Processor. Many LLIDs, such as the Quad Relay LLID, have more than one functional output associated with it. A comm loss with such a multiple function board, will generate multiple diagnostics. Refer to the chiller's wiring diagrams to relate the occurrence of multiple communication diagnostics back to the physical LLID boards that they have been assigned to (bound).*

**Table 31. Diagnostics – communication**

Diagnostic Name	Affects Target	Severity	Persistence	Active Modes [Inactive Modes]	Criteria	Reset Level
Comm Loss: AFD 1A	Circuit	Immediate	NonLatch	All	Continual loss of communication between the MP and the Functional ID has occurred for a 30 second period	Remote
Comm Loss: AFD 2A	Circuit	Immediate	NonLatch	All	Continual loss of communication between the MP and the Functional ID has occurred for a 30 second period	Remote
Comm Loss: Chiller % Capacity Output	None	Info	Latch	All	Continual loss of communication between the MP and the Functional ID has occurred for a 30 second period	Remote

**Table 31. Diagnostics – communication (continued)**

Diagnostic Name	Affects Target	Severity	Persistence	Active Modes [Inactive Modes]	Criteria	Reset Level
Comm Loss: Cond Fan Enable Shared Ckt1&2	None	Info	Latch	All	Continual loss of communication between the MP and the Functional ID has occurred for a 30 second period. This is an info warning, as it is conceivable that the circuit may run without the center shared fan deck working if there are many other coils/fans on the circuits	Remote
Comm Loss: Cond Rfgt Pressure Ckt1	Circuit	Immediate	Latch	All	Continual loss of communication between the MP and the Functional ID has occurred for a 30 second period	Remote
Comm Loss: Cond Rfgt Pressure Ckt2	Circuit	Immediate	Latch	All	Continual loss of communication between the MP and the Functional ID has occurred for a 30 second period	Remote
Comm Loss: Condenser Fan Enable Ckt1	Circuit	Normal	Latch	All	Continual loss of communication between the MP and the Functional ID has occurred for a 30 second period	Remote
Comm Loss: Condenser Fan Enable Ckt2	Circuit	Normal	Latch	All	Continual loss of communication between the MP and the Functional ID has occurred for a 30 second period	Remote
Comm Loss: Discharge Temperature Ckt1	Circuit	Normal	Latch	All	Continual loss of communication between the MP and the Functional ID has occurred for a 30 second period	Remote
Comm Loss: Discharge Temperature Ckt2	Circuit	Normal	Latch	All	Continual loss of communication between the MP and the Functional ID has occurred for a 30 second period	Remote
Comm Loss: Drive Cooling BP Valve Ckt1	Circuit	Normal	Latch	All	Continual loss of communication between the MP and the Functional ID has occurred for a 30 second period. Note: The same diagnostic is used for comm loss with the stepper motor driven bypass valve in the Drive Cooling Temp Control = DCTC or DCTW configurations as for comm loss with the "Drive Cooling 3-Way Valve Command Outputs Ckt1 &2" dual analog I/O lliid in the TWAV configuration	Remote
Comm Loss: Drive Cooling BP Valve Ckt2	Circuit	Normal	Latch	All	Continual loss of communication between the MP and the Functional ID has occurred for a 30 second period. Note: The same diagnostic is used for comm loss with the stepper motor driven bypass valve in the Drive Cooling Temp Control = DCTC or DCTW configurations as for comm loss with the "Drive Cooling 3-Way Valve Command Outputs Ckt1 &2" dual analog I/O lliid in the TWAV configuration	Remote
Comm Loss: Drive Cooling IL Valve Ckt1	Circuit	Normal	Latch	All	Continual loss of communication between the MP and the Functional ID has occurred for a 30 second period	Remote
Comm Loss: Drive Cooling IL Valve Ckt2	Circuit	Normal	Latch	All	Continual loss of communication between the MP and the Functional ID has occurred for a 30 second period	Remote
Comm Loss: Drive Cooling Sply Temp Ckt1	Circuit	Norma	Latch	All	Continual loss of communication between the MP and the Functional ID has occurred for a 30 second period. While this diagnostic is active, the associated Drive Cooling ByPass Valve shall be commanded fully closed	Remote

## Diagnostics

**Table 31. Diagnostics – communication (continued)**

Diagnostic Name	Affects Target	Severity	Persistence	Active Modes [Inactive Modes]	Criteria	Reset Level
Comm Loss: Drive Cooling Sply Temp Ckt2	Circuit	Norma	Latch	All	Continual loss of communication between the MP and the Functional ID has occurred for a 30 second period. While this diagnostic is active, the associated Drive Cooling ByPass Valve shall be commanded fully closed	Remote
Comm Loss: Emergency Stop	Chiller	Normal	Latch	All	Continual loss of communication between the MP and the Functional ID has occurred for a 30 second period	Remote
Comm Loss: Evap Rfgt Pool Temp Ckt1	Circuit and Chiller	Special Action and Info	Latch	All	Continual loss of communication between the MP and the Functional ID has occurred for a 30 second period Note: The Evap Pool Temp Sensors are used for both On and Off -cycle freeze protection. Substitute Suction Pressure to Temperature conversion for freeze protection functions	Remote
Comm Loss: Evap Rfgt Pool Temp Ckt2	Circuit and Chiller	Special Action and Info	Latch	All	Continual loss of communication between the MP and the Functional ID has occurred for a 30 second period Note: The Evap Pool Temp Sensors are used for both On and Off -cycle freeze protection. Substitute Suction Pressure to Temperature conversion for freeze protection functions	Remote
Comm Loss: Evaporator Entering Water Temperature	Chiller	Normal	Latch	All	Continual loss of communication between the MP and the Functional ID has occurred for a 30 second period. Note: Entering Water Temp Sensor is used in EXV pressure control as well as ice making & CHW reset, so it must cause a unit shutdown even if Ice or CHW reset is not installed	Remote
Comm Loss: Evaporator Leaving Water Temperature	Chiller	Normal	Latch	All	Continual loss of communication between the MP and the Functional ID has occurred for a 30 second period	Remote
Comm Loss: Evaporator Rfgt Liquid Level Ckt1	Circuit	Normal	Latch	All	Continual loss of communication between the MP and the Functional ID has occurred for a 30 second period	Remote
Comm Loss: Evaporator Rfgt Liquid Level Ckt2	Circuit	Normal	Latch	All	Continual loss of communication between the MP and the Functional ID has occurred for a 30 second period	Remote
Comm Loss: Evaporator Water Flow Switch	Chiller	Immediate	Latch	All	Continual loss of communication between the MP and the Functional ID has occurred for a 30 second period	Remote
Comm Loss: Evaporator Water Pump Relay	Chiller	Normal	Latch	All	Continual loss of communication between the MP and the Functional ID has occurred for a 30 second period.	Remote
Comm Loss: Expansion Valve Ckt1	Circuit	Normal	Latch	All	Continual loss of communication between the MP and the Functional ID has occurred for a 30 second period	Remote
Comm Loss: Expansion Valve Ckt2	Circuit	Normal	Latch	All	Continual loss of communication between the MP and the Functional ID has occurred for a 30 second period	Remote
Comm Loss: Ext Noise Reduction Command	None	Info	Latch	All	Continual loss of communication between the MP and the Functional ID has occurred for a 30 second period	Remote

**Table 31. Diagnostics – communication (continued)**

<b>Diagnostic Name</b>	<b>Affects Target</b>	<b>Severity</b>	<b>Persistence</b>	<b>Active Modes [Inactive Modes]</b>	<b>Criteria</b>	<b>Reset Level</b>
Comm Loss: External Auto/ Stop	Chiller	Normal	Latch	All	Continual loss of communication between the MP and the Functional ID has occurred for a 30 second period	Remote
Comm Loss: External Chilled/Hot Water Setpoint	External Chilled Water Setpoint	Special Action	Latch	All	Continual loss of communication between the MP and the Functional ID has occurred for a 30 second period. Chiller shall discontinue use of the External Chilled Water Setpoint source and revert to the next higher priority for setpoint arbitration	Remote
Comm Loss: External Ckt Lockout Ckt1	None	Info	Latch	All	Continual loss of communication between the MP and the Functional ID has occurred for a 30 second period. MP will hold the last lockout state (enabled or disabled) that was in effect at the time of comm loss	Remote
Comm Loss: External Ckt Lockout Ckt2	None	Info	Latch	All	Continual loss of communication between the MP and the Functional ID has occurred for a 30 second period. MP will hold the last lockout state (enabled or disabled) that was in effect at the time of comm loss	Remote
Comm Loss: External Demand Limit Setpoint	External Current Limit Setpoint	Special Action	Latch	All	Continual loss of communication between the MP and the Functional ID has occurred for a 30 second period. Chiller shall discontinue use of the External Current limit setpoint and revert to the next higher priority for Current Limit setpoint arbitration	Remote
Comm Loss: External Ice Building Command	Ice Making Mode	Special Action	Latch	All	Continual loss of communication between the MP and the Functional ID has occurred for a 30 second period. Chiller shall revert to normal (non-ice building) mode regardless of last state	Remote
Comm Loss: Fan Inverter Fault Ckt1	None	Info	Latch	All	Continual loss of communication between the MP and the Functional ID has occurred for a 30 second period	Remote
Comm Loss: Fan Inverter Fault Ckt2	None	Info	Latch	All	Continual loss of communication between the MP and the Functional ID has occurred for a 30 second period.	Remote
Comm Loss: Fan Inverter Speed Cmd Ckt1	Circuit	Normal	Latch	All	Continual loss of communication between the MP and the Functional ID has occurred for a 30 second period	Remote
Comm Loss: Fan Inverter Speed Cmd Ckt2	Circuit	Normal	Latch	All	Continual loss of communication between the MP and the Functional ID has occurred for a 30 second period	Remote
Comm Loss: Fan Inverter Speed Cmd Shared Ckt1&2	None	Info	Latch	All	Continual loss of communication between the MP and the Functional ID has occurred for a 30 second period. This is an info warning, as it is conceivable that the circuit may run without the center shared fan deck working if there are many other coils/fans on the circuits	
Comm Loss: Heat/Cool Switch	Heat Mode	Special Action	Latch	All	Continual loss of communication between the MP and the Functional ID has occurred for a 30 second period. Chiller shall revert to normal (non-ice building) mode regardless of last state	Remote
Comm Loss: Ice-Making Status	Ice-Machine	Special Action	Latch	All	Continual loss of communication between the MP and the Functional ID has occurred for a 30 second period. Chiller shall revert to normal (non-ice building) mode regardless of last state	Remote

**Table 31. Diagnostics – communication (continued)**

<b>Diagnostic Name</b>	<b>Affects Target</b>	<b>Severity</b>	<b>Persistence</b>	<b>Active Modes [Inactive Modes]</b>	<b>Criteria</b>	<b>Reset Level</b>
Comm Loss: Local BAS Interface	Chiller	Info	NonLatch	All	Continual loss of communication between the MP and the Functional ID has occurred for a 30 second period. Use last valid BAS setpoints. Diagnostic is cleared when successful communication is established with the LonTalk LLID (LCIC) or BacNet LLID (BCIC).	Remote
Comm Loss: Off-cycle Freeze Protection Relay	Chiller	Info	Latch	All	Continual loss of communication between the MP and the Functional ID has occurred for a 30 second period.	Remote
Comm Loss: Oil Loss Level Sensor Input – Ckt1	Circuit	Normal	Latch	All	Continual loss of communication between the MP and the Functional ID has occurred for a 30 second period	Remote
Comm Loss: Oil Loss Level Sensor Input – Ckt2	Circuit	Normal	Latch	All	Continual loss of communication between the MP and the Functional ID has occurred for a 30 second period	Remote
Comm Loss: Oil Pressure Cprsr1A	Circuit	Immediate	Latch	All	Continual loss of communication between the MP and the Functional ID has occurred for a 30 second period	Remote
Comm Loss: Oil Pressure Cprsr2A	Circuit	Immediate	Latch	All	Continual loss of communication between the MP and the Functional ID has occurred for a 30 second period	Remote
Comm Loss: Op Status Programmable Relays	None	Info	Latch	All	Continual loss of communication between the MP and the Functional ID has occurred for a 30 second period	Remote
Comm Loss: Outdoor Air Temperature	Chiller	Normal Shutdown	Latch	All	Continual loss of communication between the MP and the Functional ID has occurred for a 30 second period. For RTAE if this diagnostic occurs, operational pumpdown will be performed regardless of the last valid temperature	Remote
Comm Loss: Suction Rfgr Pressure Ckt1	Circuit	Immediate	Latch	All [Ckt/Cprsr lock out]	Continual loss of communication between the MP and the Functional ID has occurred for a 30 second period. Note: This diagnostic is replaced by diagnostic 5FB below with Rev 15.0	Remote
Comm Loss: Suction Rfgr Pressure Ckt2	Circuit	Immediate	Latch	All [Ckt/Cprsr lock out]	Continual loss of communication between the MP and the Functional ID has occurred for a 30 second period. Note: This diagnostic is replaced by diagnostic 5FD below with Rev 15.0	Remote
Comm Loss: Winding Temp 1 Cprsr1A	Circuit	Normal	Latch	All	Continual loss of communication between the MP and the Functional ID has occurred for a 30 second period	Remote
Comm Loss: Winding Temp 1 Cprsr2A	Circuit	Normal	Latch	All	Continual loss of communication between the MP and the Functional ID has occurred for a 30 second period	Remote
Comm Loss: Winding Temp 2 Cprsr1A	Circuit	Normal	Latch	All	Continual loss of communication between the MP and the Functional ID has occurred for a 30 second period	Remote
Comm Loss: Winding Temp 2 Cprsr2A	Circuit	Normal	Latch	All	Continual loss of communication between the MP and the Functional ID has occurred for a 30 second period	Remote





# Unit Wiring

The following table provides a list of electrical schematics, field wiring diagrams and connection diagrams. Complete wiring package is documented in

AC-SVE001\*-EN. A laminated wiring diagram booklet is also shipped with each unit.

Document Number	Description
2311-4803 Sheet 1 Sheet 2 Sheet 3 Sheet 4 Sheet 5 Sheet 6 Sheet 7	Schematic Wiring Devices, Descriptions, Locations, Notes Adaptive Frequency Drive, Circuit 1 Adaptive Frequency Drive, Circuit 2 Condenser Fans, Circuit 1 Condenser Fans, Circuit 2 Circuit Boards Circuit Boards and Unit Sensors
2311-5014	Unit Field Wiring
2311-5066	Panel Component Location
5724-2711	Assembly; Conduit Routing
5724-2721	Assembly; Sensor Routing
5724-2731	Fan/Harness Location Diagram



## Log and Check Sheets

The following are included for use as appropriate, for installation completion verification before Trane start-up is scheduled, and for reference during the Trane start-up. Where the log or check sheet also exists outside of this publication as standalone literature, the literature order number is also listed.

- Ascend™ Model ACR Installation Completion Check Sheet and Request for Trane Service (AC-ADF001\*-EN)
- Operator Log

# Ascend™ Model ACR Installation Completion Check Sheet and Request for Trane Service

**Important:** A copy of this completed form must be submitted to the Trane service agency that will be responsible for the start-up of the chiller. Start-up will NOT proceed unless applicable items listed in this form have been satisfactorily completed.

**To:** \_\_\_\_\_

**Trane Service Office:** \_\_\_\_\_

**S.O. Number:** \_\_\_\_\_

**Serial Numbers:** \_\_\_\_\_

**Job/Project Name:** \_\_\_\_\_

**Address:** \_\_\_\_\_

**The following items are being installed and will be completed by:** \_\_\_\_\_

**Important:** Start-up must be performed by Trane or an agent of Trane specifically authorized to perform start-up and warranty of Trane® products. Contractor shall provide Trane (or an agent of Trane specifically authorized to perform start-up) with notice of the scheduled start-up at least two weeks prior to the scheduled start-up.

**Important:** It is required that heaters are energized for a minimum of 24 hours prior to start up. Therefore, chiller should have power for this amount of time before Trane Service arrives to do start-up.

Check boxes if the task is complete or if the answer is "yes".

## 1. Chiller

- Installation meets foundation requirements.
- In place and piped.
- Isolation pads or elastomeric pads installed (optional).
- For units with InvisiSound™ Ultimate Option (model number digit 12 = 3), compressor mounting bolts have been removed.

## 2. Refrigerant Pressure Check

- PRIOR to water being pumped into system, use gauges to verify positive pressure in the evaporator and condenser. Lack of pressure could indicate a system leak. When charging in the factory, approximately 95% of the refrigerant charge is isolated in the evaporator,

and the other 5% is contained in the condenser and compressor. In the event that no pressure is present, contact local Trane service.

**Note:** Verification must be done by gauges. Do NOT rely only on values from unit transducers.

## 3. Piping

- Water piping flushed before making final connections to the system
  - Chilled water piping connected to:
    - Evaporator
    - Air handling unit
    - Pumps
    - Flow switch or flow proving device installed (if not factory provided)
    - Strainer installed and cleaned
- Water supply connected to filling system
- Does unit have freeze inhibitor? If unit has freeze inhibitor:
  - Verify type and concentration correct per unit submittal
  - Calculate and record freeze point of the solution: \_\_\_\_\_
- Systems filled
- Pumps run, air bled from system
- Strainer installed and cleaned
- Relief valve ventilation piping installed (if applicable)

## 4. Flow balancing valves installed

- Leaving chilled water

## 5. Gauges, thermometers, and air vents

- Installed on both sides of evaporator

## 6. Wiring

- Wire size per submittal and NEC 310-16
- Full power available
- Interconnecting wiring, starter to panel (as required)
- External interlocks (flow switch, pumps auxiliary, etc.)
- Chilled water pump (connected and tested)
- 115 Vac power available for service tools
- All controls installed and connected
- Power distribution grounding type identified:
  - Solidly Grounded (Center Ground Wye)
  - or-
  - Non-Solidly Grounded (Any Delta, High Impedance Ground, or Ungrounded Wye)

## 7. Testing



# Log and Check Sheets

- Dry nitrogen available for pressure testing
- Trace gas amounts of R-134a available for leak testing, if necessary

- 8. Refrigerant on job site (if nitrogen charge option, model number digit 15 = 2, is chosen)
- 9. Systems can be operated under load conditions
- 10. Heaters

- If unit was factory charged (model number digit 15 = 1), energize heaters for 24 hours prior to start up.

**Important: It is required that chiller heaters are energized for a minimum of 24 hours prior to start up. Therefore, chiller should have power for this amount of time before Trane Service arrives to do start-up.**

- If unit has nitrogen charge (model number digit 15 = 2), contact Trane Service for unit charging prior to start-up.

**Important: Do NOT apply shore power to unit with nitrogen charge. Shore power will drive EXV valves, inhibiting ability to adequately vac and charge unit.**

### 11. Owner Awareness

- Does the owner have a copy of the MSDS for refrigerant?

**Note: Additional time required to properly complete the start-up and commissioning, due to any incompleteness of the installation, will be invoiced at prevailing rates.**

This is to certify that the Trane® equipment has been properly and completely installed, and that the

applicable items listed above have been satisfactorily completed.

**Checklist completed by:** \_\_\_\_\_

**Signed:** \_\_\_\_\_

**Date:** \_\_\_\_\_

In accordance with your quotation and our purchase order number \_\_\_\_\_, we will therefore require the presence of Trane service on this site, for the purpose of start-up and commissioning, by \_\_\_\_\_ (date).

**Note: Minimum two-week advance notification is required to allow scheduling of the chiller start-up.**

### Additional Comments/Instructions:

---

---

---

---

---

---

---

---

**Note: A copy of this completed form must be submitted to the Trane Service Office that will be responsible for start-up of chiller.**

# Operator Log

<b>Ascend™ ACR Chiller with UC800 Controller - Tracer® AdaptiView™ Reports - Log Sheet</b>				
	<b>Start</b>	<b>15 minutes</b>	<b>30 minutes</b>	<b>1 hour</b>
EVAPORATOR				
Active Chilled Water Setpoint				
Entering Water Temperature				
Leaving Water Temperature				
Ckt 1				
Saturated Refrigerant Temperature (°F)				
Refrigerant Pressure (psia)				
Approach Temperature (°F)				
Water Flow Status				
Spillover Tank Liquid Level (in)				
EXV % Open				
Ckt 2				
Saturated Refrigerant Temperature (°F)				
Refrigerant Pressure (psia)				
Approach Temperature (°F)				
Water Flow Status				
Spillover Tank Liquid Level (in)				
EXV % Open				
CONDENSER				
Outdoor Air Temperature				
Ckt 1				
Air Flow %				
Saturated Refrigerant Temperature (°F)				
Refrigerant Pressure (psia)				
Ckt 2				
Air Flow %				
Saturated Refrigerant Temperature (°F)				
Refrigerant Pressure (psia)				
COMPRESSOR 1A				
Running Status				
Starts				
Running Time (Hr:Min)				
Oil Pressure (psia)				
MOTOR 1A				
Active Demand Limit Setpoint				
Average Motor Current (%)				



## Log and Check Sheets

<b>Ascend™ ACR Chiller with UC800 Controller - Tracer® AdaptiView™ Reports - Log Sheet</b>				
	<b>Start</b>	<b>15 minutes</b>	<b>30 minutes</b>	<b>1 hour</b>
Percent Speed				
AFD Average Input Voltage (Volts)				
AFD Input Power (kW)				
AFD Output Power (kW)				
AFD Speed (rpm)				
<b>COMPRESSOR 2A</b>				
Running Status				
Starts				
Running Time (Hr:Min)				
Oil Pressure (psia)				
<b>MOTOR 2A</b>				
Active Demand Limit Setpoint				
Average Motor Current (%)				
Percent Speed				
AFD Average Input Voltage (Volts)				
AFD Input Power (kW)				
AFD Output Power (kW)				
AFD Speed (rpm)				

Date:
Technician:
Owner:





Ingersoll Rand (NYSE: IR) advances the quality of life by creating comfortable, sustainable and efficient environments. Our people and our family of brands – including Club Car®, Ingersoll Rand®, Thermo King® and Trane® – work together to enhance the quality and comfort of air in homes and buildings; transport and protect food and perishables; and increase industrial productivity and efficiency. We are a global business committed to a world of sustainable progress and enduring results.



[ingersollrand.com](http://ingersollrand.com)

Ingersoll Rand has a policy of continuous product and product data improvements and reserves the right to change design and specifications without notice.  
We are committed to using environmentally conscious print practices.