



Product Catalog

Ascend™ Air-Cooled Chiller Model ACR

150 to 550 Nominal Tons





Introduction

Overview of Design

The air-cooled chiller was designed to meet the demanding requirements of today's environment. The design transforms technology into performance on which you can depend.

Trane engineers brought innovation to every component in the next-generation Trane® chiller. The result: the high efficiency, improved system flexibility and performance, and low sound levels—all while delivering improved reliability and lower maintenance requirements.

At the core of the air-cooled chiller's performance is AdaptiSpeed™ technology—the integration of an adaptive frequency drive efficiently tuned to match perfectly the permanent magnet compressor motors. The result is improved full load efficiency, in addition to the typical benefits of part load efficiency.

AdaptiSpeed™ Technology

AdaptiSpeed™ technology delivers unmatched efficiency with some of the lowest sound levels in the industry.

- Variable volume ratio screw compressor—Optimized for variable-speed operation, it delivers peak efficiency under all operating conditions.
- Variable speed, permanent magnet motors—The compressor's and condenser fans' permanent magnet motor design is up to 4 percent more efficient than conventional induction motors.

Copyright

This document and the information in it are the property of Trane, and may not be used or reproduced in whole or in part without written permission. Trane reserves the right to revise this publication at any time, and to make changes to its content without obligation to notify any person of such revision or change.

Trademarks

All trademarks referenced in this document are the trademarks of their respective owners.

Revision History

Added the indirect free-cooling, pump package, and seismic options. Updates included the following chapters:

- Model Number Descriptions
- General Data
- Electrical
- Dimensions and Weights
- Mechanical Specifications
- Options



Table of Contents

- Features and Benefits 5
 - Technology 5
 - Cost of Ownership 5
 - Reliability 5
 - Precision Control 5
- Application Considerations 7
 - Water Treatment 7
 - Effect of Altitude on Capacity 7
 - Ambient Limitations 7
 - Water Flow Limits 7
 - Water Temperature 8
 - Variable Flow in the Evaporator 9
 - Series Chiller Arrangements 9
 - Typical Water Piping 10
 - Multiple Unit Operation 10
 - Thermal Battery Cooling System Operation 11
 - Unit Placement 11
 - Unit Location 12
- Model Number Descriptions 14
 - Unit Model Number 14
- General Information 16
 - Unit Length 16
 - General Data 17
- Controls 24
 - Symbio™ 800 Controller 24
 - Tracer AdaptiView TD7 Operator Interface 24
 - System Integration 25
 - Symbio 800 Controls 26
 - Integrated Comfort System (ICS) 29
- Electrical 30
 - Electrical Data 30
 - Short Circuit Rating 38
 - Customer Wiring 43
- Electrical Connections 50



Table of Contents

Dimensions and Weights	54
Weights.....	54
Service Clearance.....	57
Unit Dimensions.....	58
Mechanical Specifications	75
Certified AHRI Performance.....	75
Refrigeration Circuits.....	75
Evaporator	75
Condenser and Fans	75
Compressor and Lube Oil System	76
Drive Cooling System	76
Unit Controls	76
Adaptive Frequency Drive	78
Chilled Water Reset	78
Factory Mounted Flow Proving.....	78
Factory Mounted Flow Measurement.....	78
Options	79
Application Options.....	79
Electrical Options	79
Control Options.....	80
Sound Options	80
Other Options	81



Features and Benefits

Technology

- AdaptiSpeed™ technology assures optimal performance at all operating conditions
 - Permanent magnet motor - up to 4% more efficient than an induction motor
 - AFD Adaptive Frequency™ Drive
 - Soft start provided as standard to reduce power in-rush at start-up
 - Available with Passive Harmonic Filtering achieving 5% TDD (optional)
 - Variable volume ratio compressor design optimized for efficiency at all load conditions
 - Rotor profile designed for maximum efficiency at higher speeds
- Shuttle valve enhances compressor oil management
- Variable speed permanent magnet motors on ALL condenser fans for increased efficiency and lower sound
- Larger diameter condenser fans operate at lower speed with optimized blade design
- Compact, high-efficiency, integrated low refrigerant charge evaporator design
- Integral compressor muffler lowers sound levels by 4-10 dB compared to previous design
- Optional metallic discharge and suction bellows reduce compressor sound by 8-10 dB

Cost of Ownership

- Industry-leading efficiency
 - Over 18% better full load efficiency than ASHRAE 90.1-2016 Path B
 - Minimizing kW demand and infrastructure
 - Over 22% higher IPLV than ASHRAE 90.1-2016 Path B
 - Minimizing kW usage
- High power factor at all load points reducing the need for power factor correction capacitors
- Variable speed drives on all condenser fans save energy at part load operation, as well as lower sound levels even further as fan speeds are reduced during part load operation.
- Transverse modular coil design for easy access for coil cleaning
- Up to 40% lower refrigerant charge compared to previous evaporator designs
- Factory-engineered, tested and installed sound control options reduce jobsite time and cost
- Three levels of sound reduction available to meet various job site acoustical requirements

Reliability

- Industrial bearing system designed for the life of the chiller
- Shuttle valve reduces the differential oil pressure required for cold weather start-up
- Design eliminates brazed coil u-bends, significantly reduces potential for refrigerant leaks
- Enhanced factory-applied corrosion protection available
- Rapid Restart capability minimizes downtime

Precision Control

- 7-inch color touch screen display with graphics
- Powered by Symbio™ 800 industry-leading control algorithms — Enhanced flow management provides unmatched system performance in variable flow water systems
- Adaptive Control™ keeps the chiller running in extreme conditions
 - Tight set point control



Features and Benefits

- Graphical trending
- Maximized chiller update
- BACnet®, Modbus™, LonTalk®, communications protocol interface available without the need for gateways
- Optional condenser fan speed control to help meet preset nighttime sound requirements



Application Considerations

Certain application constraints should be considered when sizing, selecting, and installing Trane chillers. Unit and system reliability is often dependent on properly and completely complying with these considerations. When the application varies from the guidelines presented, it should be reviewed with your local sales engineer.

Note: *The terms water and solution are used interchangeably in the following paragraphs.*

Water Treatment

The use of untreated or improperly treated water may result in scaling, erosion, corrosion, and algae or slime buildup. This will adversely affect heat transfer between the water and system components. Proper water treatment must be determined locally and depends on the type of system and local water characteristics.

Neither salt nor brackish water is recommended for use in Trane air-cooled chillers. Use of either will lead to a shortened life. Trane encourages the employment of a qualified water treatment specialist, familiar with local water conditions, to assist in the establishment of a proper water treatment program.

Foreign matter in the chilled water system can also increase pressure drop and, consequently, reduce water flow. For this reason it is important to thoroughly flush all water piping to the unit before making the final piping connections to the unit.

Effect of Altitude on Capacity

At elevations substantially above sea level, the decreased air density will decrease condenser capacity and, therefore, unit capacity and efficiency.

Ambient Limitations

Trane chillers are designed for year-round operation over a range of ambient temperatures.

- Standard Ambient Range = 32 to 105°F (0 to 40.6°C)
- Low Ambient Range = 0 to 105°F (-17.7 to 40.6°C)
- Extreme Low Ambient Range:
 - 150 to 300 ton units: -16° to 105°F (-26.7 to 40.6°C)
 - 375 to 550 ton units: -15° to 105°F (-26.1 to 40.6°C)
- High Ambient Range = 32 to 125°F (0 to 52°C)
- Wide Ambient Range = 0 to 125°F (-17.7 to 52°C)

Note: *Direct free-cooling (DFC) option operates down to -40°F (-40°C). The mechanical cooling ambient range is unaffected by the DFC option.*

The minimum ambient temperatures are based on still conditions (winds not exceeding five mph). Greater wind speeds will result in a drop in head pressure, therefore increasing the minimum starting and operating ambient temperature. The AdaptiveFrequency™ microprocessor will attempt to keep the chiller on-line when high or low ambient conditions exist, making every effort to avoid nuisance trip-outs and provide the maximum allowable tonnage.

Water Flow Limits

The minimum water flow rates are given in the General Data chapter of this catalog. Evaporator flow rates below the tabulated values will result in laminar flow causing freeze-up problems, scaling, stratification and poor control.

The maximum evaporator water flow rate is also given in General Data. Flow rates exceeding those listed may result in very high pressure drop across the evaporator and/or excessive tube erosion.

Note: Flow rates in the general data tables are for water only. They do not include freeze inhibitors.

Flow Rates Out of Range

Many process cooling jobs require flow rates that cannot be met with the minimum and maximum published values within the evaporator. A simple piping change can alleviate this problem. For example: a plastic injection molding process requires 80 gpm (5.0 l/s) of 50°F (10°C) water and returns that water at 60°F (15.6°C). The selected chiller can operate at these temperatures, but has a minimum flow rate of 106 gpm (6.6 l/s). The system layout in the figure below can satisfy the process.

Figure 1. Flow rate out of range systems solution

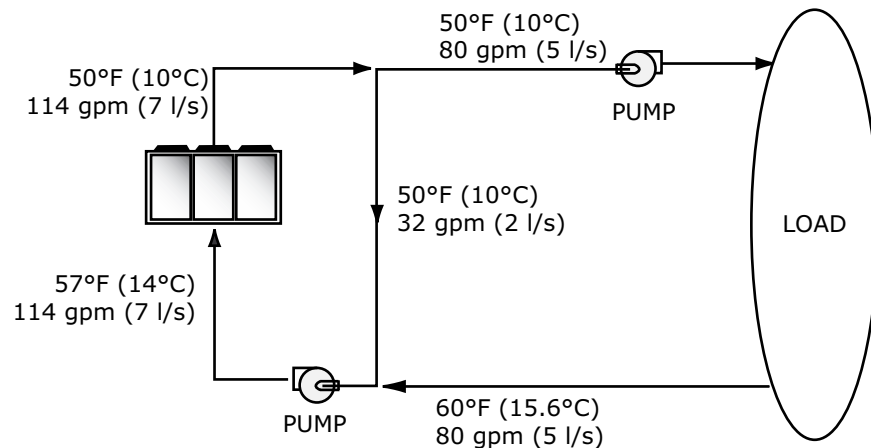

Flow Proving

Trane provides a factory-installed water flow switch monitored by Symbio™ 800 controller which protects the chiller from operating in loss of flow conditions.

Water Temperature

Leaving Water Temperature Limits

Trane chillers have distinct leaving water categories:

- Standard, with a leaving solution range of 40 to 68°F (4.4 to 20°C)
- Low temperature process cooling, with leaving solution less than 40°F (4.4°C)
- Ice-making, with a leaving solution range of 20 to 68°F (-6.7 to 20°C)

Since leaving solution temperatures below 40°F (4.4°C) result in suction temperature at or below the freezing point of water, a glycol solution is required for all low temperature and ice-making machines. Ice making control includes dual setpoints and safeties for ice making and standard cooling capabilities. Consult your local Trane account manager for applications or selections involving low temperature or ice making machines.

The maximum water temperature that can be circulated through the evaporator when the unit is not operating is 125°F (52°C). Evaporator damage may result above this temperature.

Leaving Water Temperature Out of Range

Many process cooling jobs require temperature ranges that cannot be met with the minimum and maximum published values for the chiller. A simple piping change can alleviate this problem. For example, a laboratory load requires 238 gpm (15 l/s) of water entering the process at 86°F (30°C) and returning at 95°F (35°C). The chiller's maximum leaving chilled water temperature of 68°F (20°C) prevents direct supply to the load. In the example shown, both the chiller and process flow rates are equal, however, this is not necessary. For example, if the chiller

had a higher flow rate, there would be more water bypassing and mixing with warm water returning to the chiller.

Figure 2. Temperature out of range system solution

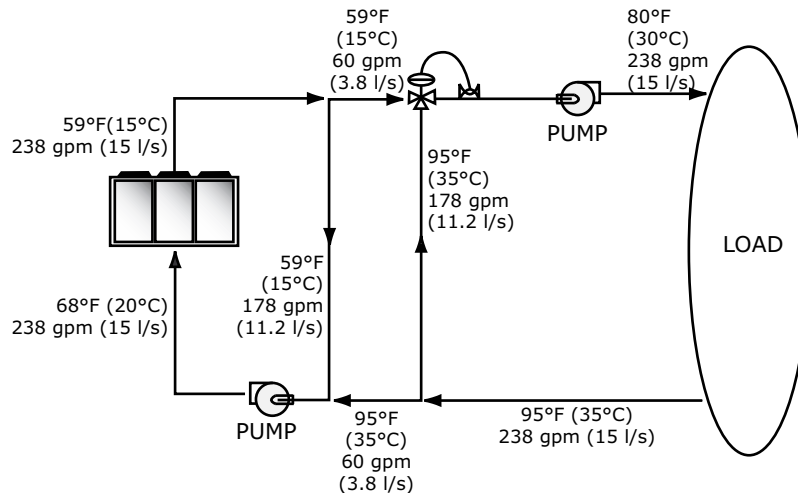

Variable Flow in the Evaporator

An attractive chilled water system option may be a variable primary flow (VPF) system. VPF systems present building owners with several cost saving benefits that are directly related to the pumps. The most obvious cost savings result from eliminating the secondary distribution pump, which in turn avoids the expense incurred with the associated piping connections (material, labor), electrical service, and variable frequency drive. Building owners often cite pump related energy savings as the reason that prompted them to install a VPF system.

The evaporator on the chiller can withstand up to 50 percent water flow reduction as long as this flow is equal to or above the minimum flow rate requirements.

With the help of a software analysis tool such as System Analyzer™, DOE-2 or TRACE™, you can determine whether the anticipated energy savings justify the use of variable primary flow in a particular application. It may also be easier to apply variable primary flow in an existing chilled water plant. Unlike the "decoupled" system design, the bypass can be positioned at various points in the chilled water loop and an additional pump is unnecessary.

Series Chiller Arrangements

Another energy saving strategy is to design the system around chillers arranged in series. The actual savings possible with such strategies depends on the application dynamics and should be researched by consulting your Trane® Systems Solutions Representative and applying an analysis tool from the Trace software family. It is possible to operate a pair of chillers more efficiently in a series chiller arrangement than in a parallel arrangement. It is also possible to achieve higher entering to leaving chiller differentials, which may, in turn, provide the opportunity for lower chilled water design temperature, lower design flow, and resulting installation and operational cost savings. The Trane screw compressor also has excellent capabilities for "lift," which provides an opportunity for savings on the evaporator water loop.

Series chiller arrangements can be controlled in several ways. The figure below shows a strategy where each chiller is trying to achieve the system design set point. If the cooling load is less than 50 percent of the systems capabilities, either chiller can fulfill the demand. As system loads increase, the Chiller 2 becomes preferentially loaded as it attempts to meet the leaving chilled water setpoint. Chiller 1 will finish cooling the leaving water from Chiller 2 down to the system design setpoint.

Staggering the chiller set points is another control technique that works well for preferentially loading Chiller 1. If the cooling load is less than 50 percent of the system capacity, Chiller 1 would

be able to satisfy the entire call for cooling. As system loads increase, Chiller 2 is started to meet any portion of the load that Chiller 1 can not meet.

Figure 3. Typical series chiller arrangement

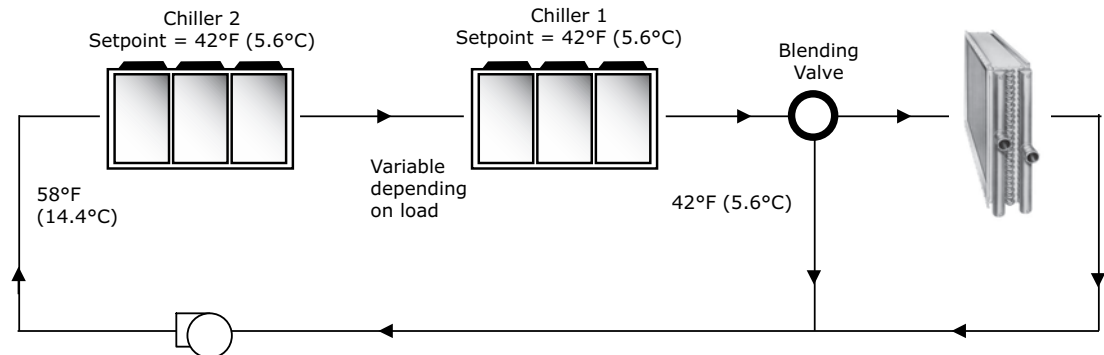

Typical Water Piping

All building water piping must be flushed prior to making final connections to the chiller. To reduce heat loss and prevent condensation, insulation should be applied. Expansion tanks are also usually required so that chilled water volume changes can be accommodated.

Avoidance of Short Water Loops

Adequate chilled water system water volume is an important system design parameter because it provides for stable chilled water temperature control and helps limit unacceptable short cycling of chiller compressors.

The chiller's temperature control sensor is located in the waterbox. This location allows the building to act as a buffer to slow the rate of change of the system water temperature. If there is not a sufficient volume of water in the system to provide an adequate buffer, temperature control can suffer, resulting in erratic system operation and excessive compressor cycling.

Typically, a two-minute water loop circulation time is sufficient to prevent short water loop issues. Therefore, as a guideline, ensure the volume of water in the chilled water loop equals or exceeds two times the evaporator flow rate. For systems with a rapidly changing load profile the amount of volume should be increased.

If the installed system volume does not meet the above recommendations, the following items should be given careful consideration to increase the volume of water in the system and, therefore, reduce the rate of change of the return water temperature.

- A volume buffer tank located in the return water piping.
- Larger system supply and return header piping (which also reduces system pressure drop and pump energy use).

Minimum Water Volume for a Process Application

If a chiller is attached to an on/off load such as a process load, it may be difficult for the controller to respond quickly enough to the very rapid change in return solution temperature if the system has only the minimum water volume recommended. Such systems may cause chiller low temperature safety trips or in the extreme case evaporator freezing. In this case, it may be necessary to add or increase the size of the mixing tank in the return line.

Multiple Unit Operation

Whenever two or more units are used on one chilled water loop, Trane recommends that their operation be coordinated with a higher level system controller for optimum system efficiency and reliability. The Trane Tracer® system has advanced chilled plant control capabilities designed to provide such operation.

Thermal Battery Cooling System Operation

A Thermal Battery™ cooling system uses the chiller to make (cooling) ice at night when utilities generate electricity more efficiently with lower demand and energy charges. The stored cooling energy reduces or even replaces mechanical cooling during the day when utility rates are at their highest. This reduced electrical demand for cooling results in significant utility cost savings and source energy savings.

Another advantage of an ice energy storage system is its ability to eliminate chiller over sizing. A “right-sized” chiller plant with ice energy storage operates more efficiently with smaller support equipment while lowering the connected load and reducing operating costs. Best of all, this system still provides a capacity safety factor and redundancy by designing reserve capacity into the ice storage system for practically no cost compared to oversized systems.

Trane air-cooled chillers are uniquely suited to low temperature applications like ice storage because of the ambient relief experienced at night. Chiller ice making efficiencies are typically similar to or even better than standard cooling daytime efficiencies as a result of night-time dry-bulb ambient relief.

Standard smart control strategies for ice storage systems are another advantage of the chiller. The dual mode control functionality is integrated right into the chiller. Trane Tracer® building management systems can measure demand and receive pricing signals from the utility and decide when to use the stored cooling and when to use the chiller.

Unit Placement

Setting the Unit

A base or foundation is not required if the selected unit location is level and strong enough to support the unit’s operating weights shown in Weights chapter.

For a detailed discussion of base and foundation construction, see the unit Installation, Operation or Maintenance (IOM) manual. Manuals are available through online product portal pages or from your local office.

HVAC equipment must be located to minimize sound and vibration transmission to the occupied spaces of the building structure it serves. If the equipment must be located in close proximity to a building, it should be placed next to an unoccupied space such as a storage room, mechanical room, etc. It is not recommended to locate the equipment near occupied, sound sensitive areas of the building or near windows. Locating the equipment away from structures will also prevent sound reflection, which can increase sound levels at property lines or other sensitive points.

Isolation and Sound Emission

Structurally transmitted sound can be reduced by elastomeric vibration eliminators. Elastomeric isolators are generally effective in reducing vibratory noise generated by compressors, and therefore, are recommended for sound sensitive installations. An acoustical engineer should always be consulted on critical applications.

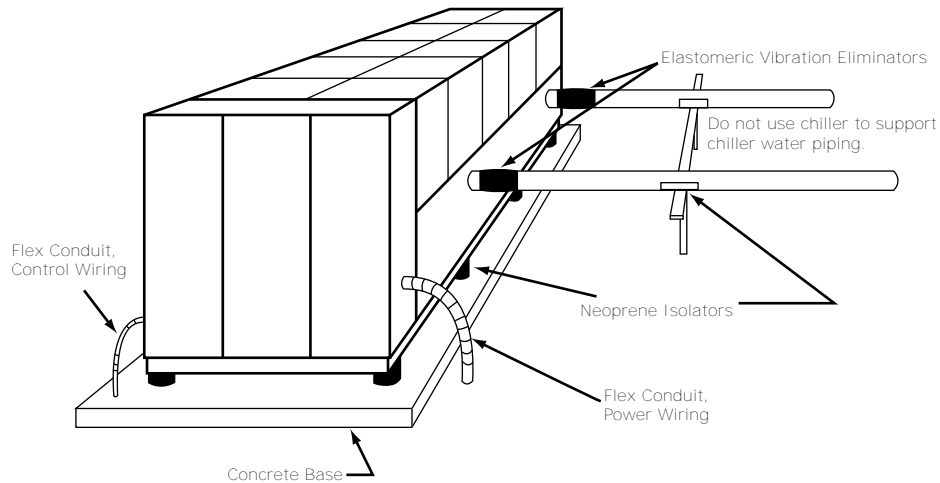
Figure 4. Installation example

For maximum isolation effect, water lines and electrical conduit should also be isolated. Wall sleeves and rubber isolated piping hangers can be used to reduce sound transmitted through water piping. To reduce the sound transmitted through electrical conduit, use flexible electrical conduit.

Local codes on sound emissions should always be considered. Since the environment in which a sound source is located affects sound pressure, unit placement must be carefully evaluated. Sound power levels for chillers are available on request.

Servicing

Adequate clearance for evaporator, condenser and compressor servicing should be provided. Recommended minimum space envelopes for servicing are located in the dimensional data section and can serve as a guideline for providing adequate clearance. The minimum space envelopes also allow for control panel door swing and routine maintenance requirements. Local code requirements may take precedence.

Unit Location

General

Unobstructed flow of condenser air is essential to maintain chiller capacity and operating efficiency. When determining unit placement, careful consideration must be given to assure a sufficient flow of air across the condenser heat transfer surface. Two detrimental conditions are possible and must be avoided: warm air recirculation and coil starvation. Air recirculation occurs when discharge air from the condenser fans is recycled back to the condenser coil inlet. Coil starvation occurs when free airflow to the condenser is restricted.

Condenser coils and fan discharge must be kept free of snow or other obstructions to permit adequate airflow for satisfactory unit operation. Debris, trash, supplies, etc., should not be allowed to accumulate in the vicinity of the air-cooled chiller. Supply air movement may draw debris into the condenser coil, blocking spaces between coil fins and causing coil starvation.

Both warm air recirculation and coil starvation cause reductions in unit efficiency and capacity due to higher head pressures. The air-cooled chiller offers an advantage over competitive equipment in these situations. Operation is minimally affected in many restricted air flow situations due to its advanced Adaptive Control™ microprocessor which has the ability to understand the operating environment of the chiller and adapt to it by first optimizing its performance and then staying on line through abnormal conditions. For example, high ambient temperatures combined with a restricted air flow situation will generally not cause the air-cooled chiller to shut down. Other chillers would typically shut down on a high pressure nuisance cut-out in these conditions.

Cross winds, those perpendicular to the condenser, tend to aid efficient operation in warmer ambient conditions. However, they tend to be detrimental to operation in lower ambients due to the accompanying loss of adequate head pressure. Special consideration should be given to low ambient units. As a result, it is advisable to protect air-cooled chillers from continuous direct winds exceeding 10 mph (4.5 m/s) in low ambient conditions.

The recommended lateral clearances are depicted in the close spacing engineering bulletin available from your local office.

Provide Sufficient Unit-to-Unit Clearance

Units should be separated from each other by sufficient distance to prevent warm air recirculation or coil starvation. Doubling the recommended single unit air-cooled chiller clearances will generally prove to be adequate. See Close-Spacing and Restricted Airflow Engineering Bulletin AC-PRB001*-EN for more information.

Walled Enclosure Installations

When the unit is placed in an enclosure or small depression, the top of the surrounding walls should be no higher than the top of the fans. The chiller should be completely open above the fan deck. There should be no roof or structure covering the top of the chiller. Ducting individual fans is not recommended. See Close-Spacing and Restricted Airflow Engineering Bulletin AC-PRB001*-EN for more information.



Model Number Descriptions

Unit Model Number

Digit 1, 2, 3, 4 — Unit Model

ACRB = Air-Cooled Screw Chiller

Digit 5, 6, 7 — Nominal Tonnage

150 = 150 Tons
165 = 165 Tons
180 = 180 Tons
200 = 200 Tons
225 = 225 Tons
250 = 250 Tons
275 = 275 Tons
300 = 300 Tons
375 = 375 Tons
380 = 380 Tons
440 = 440 Tons
450 = 450 Tons
500 = 500 Tons
550 = 550 Tons

Digit 8 — Compressor Type

4 = Mixed screw types
5 = Screw with Variable Volume Ratio

Digit 9— Unit Voltage

A = 200/60/3
B = 230/60/3
C = 380/60/3
D = 400/60/3
E = 460/60/3
F = 575/60/3
G = 400/50/3
H = 380/50/3

Digit 10 — Manufacturing Location

U = Trane Commercial Systems, Pueblo, CO USA

Digits 11, 12 — Design Sequence

****** = Factory assigned

Digit 13 — Unit Sound Package

X = InvisiSound™ Standard
L = InvisiSound™ Superior
E = InvisiSound™ Ultimate
R = InvisiSound™ Standard with Noise Reduction Request
Q = InvisiSound™ Superior with Noise Reduction Request

Digit 14 — Agency Listing

C = No Agency Listing
U = UL/cUL Listing

Digit 15 — Pressure Vessel Code

U = ASME Pressure Vessel Code
C = CRN or Canadian Equivalent Pressure Vessel Code
A = Australia Pressure Vessel Code

Digit 16 — Factory Charge

C = Refrigerant Charge R-134a
D = Nitrogen Charge, R-134a Field Supplied

Digit 17 — Auxiliary Items

X = No Auxiliary Items

Digit 18 — Evaporator Application

N = Standard Cooling
P = Low Temp Process Cooling
C = Ice Making

Digit 19, 20 — Evaporator Type

C1 = CHIL 1-pass
C2 = CHIL 2-pass
C3 = CHIL 3-pass
D1 = CHIL 1-pass with ALT tube
D2 = CHIL 2-pass with ALT tube

Digit 21 — Water Connection

X = Grooved Pipe
A = Grooved Pipe + Flange

Digit 22 — Flow Switch

C = Flow Switch Set Point 15 cm/sec
D = Flow Switch Set Point 25 cm/sec
F = Flow Switch Set Point 35 cm/sec
H = Flow Switch Set Point 45 cm/sec

Digit 23 — Insulation

N = Factory Insulation — All Cold Parts 0.75"
H = Evaporator-only Insulation for High Humidity/Low Evap Temp 1.25"

Digit 24 — Unit Application

X = Standard Ambient
L = Low Ambient
E = Extreme Low Ambient
H = High Ambient
W = Wide Ambient

Digit 25 — Condenser Length

A = 4V Condenser Coil Modules
B = 5V Condenser Coil Modules
C = 6V Condenser Coil Modules
D = 7V Condenser Coil Modules
E = 8V Condenser Coil Modules
F = 9V Condenser Coil Modules
H = 11V Condenser Coil Modules

Digit 26 — Condenser Fin Options

A = Aluminum Round Tube, Aluminum Plate Fin
C = Coated Microchannel
D = CompleteCoat™ Epoxy Coated Aluminum Fins, Aluminum Round Tube
K = Coated Copper Round Tube, Aluminum Plate Fin
M = Aluminum Microchannel
R = Copper Round Tube, Aluminum Plate Fin

Digit 27 — Fan Type

E = EC Condenser Fan Motors

Digit 28 — Compressor Starter

V = Variable Frequency Drive (1 compressor/circuit)

Digit 29 — Incoming Unit Power Line Connection

1 = Single Point Power
2 = Dual Point Unit Power Connection
3 = Single Point Power including 115V

Digit 30 — Power Line Connection Type

T = Terminal Block
C = Circuit Breaker
H = Circuit Breaker with High Fault Rated Control Panel
M = High Fault Rated Circuit Breaker with Energy Meter

Digit 31 — Short Circuit Current Rating

A = Default Short Circuit Amp Rating
B = High Short Circuit Amp Rating

Digit 32 — Electrical Accessories

X = None
B = Convenience Outlet and Under/Over Voltage Protection
C = 15A 115V Convenience Outlet (Type B)
N = 20A 115V Convenience Outlet
U = Under/Over Voltage Protection

Digit 33 — Remote Communication Option

X = None
L = LonTalk® Interface
B = BACnet® TP Interface
M = Modbus™ Interface
P = BACnet® Interface (IP)

Digit 34 — Hard Wire Communication

X = None
A = Hard Wired Bundle - All
B = Remote Leaving Water Temp Setpoint
C = Remote Leaving Temp and Demand Limit Setpoints
D = Unit Status Programmable Relay
E = Programmable Relay and Leaving Water and Demand Limit Setpoint
F = Percent Capacity
G = Percent Capacity and Leaving Water and Demand Limit Setpoint
H = Percent Capacity and Programmable Relay

Digit 35 — Smart Flow Control

X = None
F = Flow Measurement Factory Installed

Digit 36 — Structural Options

A = Standard Unit Structure
B = IBC Seismic Certification
D = Wind Load Certification
E = Combination IBC Seismic and Wind Load Certification

Digit 37 — Appearance Accessories

X = No Appearance Options
A = Architectural Louvered Panels

Digit 38 — Unit Isolation

X = None
1 = Elastomeric Isolators
4 = Seismic Elastomeric Pads

Digit 39 — Shipping Package

X = None
A = Containerization
T = Shipping Tarp Covering Full Unit
B = Containerization and Tarp

Digit 40 — Pump Package

X = None
5 = 50 HP Single Pump High Pressure with Single VFD
6 = 60 HP Single Pump High Pressure with Single VFD
7 = 75 HP Single Pump High Pressure with Single VFD

Digit 41 — Heat Recovery

X = None

Digit 42 — Free-Cooling

X = None
T = Total Direct Free-Cooling
E = Total Indirect Free-Cooling + 2V Free-Cooling Coils
H = Total Direct Free Cooling + 2V Free-Cooling Coils
F = Total Indirect Free Cooling

Digit 43 — Special

0 = None
S = Special
F = Ship to Final Finisher

Digit 44 — Line Voltage Harmonic Mitigation

X = DC Reactors (~30% TDD)
L = 5% TDD (IEEE519 Compliant)

Digit 45 — Wireless Connectivity

A = Wi-Fi
B = LTE Modem
C = Air-Fi
D = Wi-Fi and LTE Modem
E = Wi-Fi and Air-Fi
F = LTE Modem and Air-Fi
G = Wi-Fi, LTE Modem, and Air-Fi



General Information

Unit Length

For unit sizes 300 tons and smaller, units are EXTENDED length if either of the following are selected:

- Voltage: 200, 230 or 575V (model number digit 9 = A, B, or F)
- Harmonic Filtration Option: Filter circuit (model number digit 44 = L)

General Data

Table 1. General data — 150 to 275 ton units

Unit Size (tons)	150		165		180		200		225		250		275	
	4V	5V	4V	5V	4V	5V	5V	6V	5V	6V	5V	6V	6V	7V
Condenser Length^(a)														
Compressor Model	CHHSR		CHHSR		CHHSR		CHHSR		CHHSR		CHHSR		CHHSR	
Quantity #	2		2		2		2		2		2		2	
Evaporator														
Water Storage (gal)	17.5		18.7		21.9		23.9		26.6		28.7		33.0	
(L)	66.1		70.9		82.8		90.5		100.6		108.8		125.0	
2 Pass arrangement														
Evap Water Connection Size ^(b) (in)	5		5		6		6		6		6		8	
(mm)	125		125		150		150		150		150		200	
Minimum Flow ^(c) (gpm)	171		187		202		228		261		288		318	
(l/s)	10.8		11.8		12.7		14.4		16.5		18.2		20.1	
Maximum Flow ^(c) (gpm)	626		684		742		835		957		1055		1165	
(l/s)	39.5		43.1		46.8		52.7		60.4		66.5		73.5	
3 Pass arrangement														
Evap Water Connection Size ^(b) (in)	4		4		5		5		5		5		6	
(mm)	100		100		125		125		125		125		150	
Minimum Flow ^(c) (gpm)	114		124		135		152		174		192		212	
(l/s)	7.2		7.8		8.5		9.6		11.0		12.1		13.4	
Maximum Flow ^(c) (gpm)	417		456		495		557		638		703		777	
(l/s)	26.3		28.8		31.2		35.1		40.2		44.3		49.0	
Condenser														
Quantity of Coils	8		8		8		10		10		10		12	
Coil Length (in)	78.74		78.74		78.74		78.74		78.74		78.74		78.74	
(mm)	2000		2000		2000		2000		2000		2000		2000	
Coil Height (in)	50		50		50		50		50		50		50	
(mm)	1270		1270		1270		1270		1270		1270		1270	
Fins/Ft	192		192		192		192		192		192		192	
Rows	3		3		3		3		3		3		3	
Quantity of Fans #	8		8		8		10		10		10		12	
Free-Cooling^(d)														
Customer Water Connection Size (in)	n/a		n/a		n/a		6		n/a		6		n/a	
(mm)	n/a		n/a		n/a		152		n/a		152		n/a	
Qty of Coils Ckt 1 - Std Length ^(e)	n/a		n/a		n/a		4		n/a		5		n/a	



General Information

Table 1. General data — 150 to 275 ton units (continued)

Unit Size (tons)	150		165		180		200		225		250		275	
	4V	5V	4V	5V	4V	5V	4V	5V	4V	5V	4V	5V	4V	5V
Condenser Length^(a)														
Qty of Coils Ckt 1 - Ext Length ^(e)	n/a	5	n/a	5	n/a	5	n/a	5	n/a	5	n/a	5	n/a	5
Qty of Coils Ckt 2	n/a	5	n/a	5	n/a	5	n/a	5	n/a	5	n/a	5	n/a	5
Coil Length	(in)	72.49	n/a	72.49	n/a	72.49	n/a	72.49	n/a	72.49	n/a	72.49	n/a	72.49
	(mm)	1841	n/a	1841	n/a	1841	n/a	1841	n/a	1841	n/a	1841	n/a	1841
Coil Height	(in)	40	n/a	40	n/a	40	n/a	40	n/a	40	n/a	40	n/a	40
	(mm)	1016	n/a	1016	n/a	1016	n/a	1016	n/a	1016	n/a	1016	n/a	1016
Fins/Ft		192	n/a	192	n/a	192	n/a	192	n/a	192	n/a	192	n/a	192
Rows		3	n/a	3	n/a	3	n/a	3	n/a	3	n/a	3	n/a	3
Glycol Storage Volume - Std Length ^(e)	(gal)	123	n/a	123	n/a	123	n/a	123	n/a	123	n/a	123	n/a	123
	(l)	467	n/a	467	n/a	467	n/a	467	n/a	467	n/a	467	n/a	467
Glycol Storage Volume - Ext Length ^(e)	(gal)	129	n/a	129	n/a	129	n/a	129	n/a	129	n/a	129	n/a	129
	(l)	489	n/a	489	n/a	489	n/a	489	n/a	489	n/a	489	n/a	489
Ambient Temperature Range														
Standard Ambient	°F (°C)	32 to 105 (0 to 40.6)												
Low Ambient	°F (°C)	0 to 105 (-17.7 to 40.6)												
Extreme Low Ambient	°F (°C)	-16 to 105 (-26.7 to 40.6)												
High Ambient	°F (°C)	32 to 125 (0 to 52)												
Wide Ambient	°F (°C)	0 to 125 (-17.7 to 52)												
General Unit														
Refrigerant		HFC-134a												
Refrigerant Ckts	#	2												
Minimum Load	%	20	18	18	17	17	15	15	15	20	20	18	18	16
Refrigerant Charge/ckt	(lbs)	172	171	181	200	210	208	218	218	251	265	255	261	318
	(kg)	78	78	82	91	95	94	99	99	114	120	116	118	144
Oil		Trane OIL00311												
Oil Charge/ckt	(gal)	3.0	3.0	3.0	3.0	3.0	3.0	3.0	3.0	4.0	4.0	4.0	4.0	4.0
	(L)	11.4	11.4	11.4	11.4	11.4	11.4	11.4	11.4	15.1	15.1	15.1	15.1	15.1

(a) Condenser length defined by model number digit 25: 4V = A; 5V = B; 6V = C; 7V = D.
 (b) Sizes are for units without free-cooling option (model number digit 42 = X). See free-cooling section of table for water connections sizes for units with model number digit 42 = T.
 (c) Minimum and maximum flow rates apply to constant-flow chilled water systems running at AHRI conditions, without freeze inhibitors added to the water loop.
 (d) Units with free-cooling option are indicated by model number digit 42 = T.
 (e) See Unit Length section.

Table 2. General data — 300 tons units

Unit Size (tons)		300	
Condenser Length^(a)		7V	8V
Compressor Model		CHSS	CHSS
Quantity	#	2	2
Evaporator			
Water Storage	(gal)	36.0	36.0
	(L)	136.1	136.1
2 Pass arrangement			
Evap Water Connection Size ^(b)	(in)	8	8
	(mm)	200	200
Minimum Flow	(gpm)	354	354
	(l/s)	22.3	22.3
Maximum Flow	(gpm)	1299	1299
	(l/s)	81.9	81.9
3 Pass arrangement			
Evap Water Connection Size ^(b)	(in)	6	6
	(mm)	150	150
Minimum Flow	(gpm)	236	236
	(l/s)	14.9	14.9
Maximum Flow	(gpm)	866	866
	(l/s)	54.6	54.6
Condenser			
Quantity of Coils		14	16
Coil Length	(in)	78.74	78.74
	(mm)	2000	2000
Coil Height	(in)	50	50
	(mm)	1270	1270
Fins/Ft		192	192
Rows		3	3
Quantity of Fans	#	14	16
Free-Cooling^(c)			
Free-Cooling Option (model number digit 42)		X	
Free-Cooling Type		n/a	
	(in)	n/a	
Customer Water Connection Size ^(b)	(mm)	n/a	
		T	
		Direct	
		8	
		203	
		H	
		Direct	
		8	
		203	
		E	
		Indirect	
		8	
		203	
		F	
		Indirect	
		8	
		203	

Table 2. General data — 300 tons units (continued)

Unit Size (tons)		300													
Condenser Length^(a)		7V						8V							
Quantity of Free-Cooling Coils (Extended) ^(d)		n/a	15 (16)	19 (20)	15 (16)	19 (20)	15 (16)	19 (20)	15 (16)	19 (20)	15 (16)	19 (20)	15 (16)	19 (20)	
Quantity of Free-Cooling Only fans		n/a	n/a	4	n/a	4	n/a	4	N/A	4	N/A	4	N/A	4	
Coil Length	(in)	n/a	72.49	72.49	1841	72.49	1841	72.49	1841	72.49	1841	72.49	1841	72.49	
	(mm)	n/a	1841	1841	1841	1841	1841	1841	1841	1841	1841	1841	1841	1841	
Coil Height	(in)	n/a	40	40	40	40	40	40	40	40	40	40	40	40	
	(mm)	n/a	1016	1016	1016	1016	1016	1016	1016	1016	1016	1016	1016	1016	
Fins/Ft		n/a	192	192	192	192	192	192	192	192	192	192	192	192	
Rows		n/a	3	3	3	3	3	3	3	3	3	3	3	3	
Additional customer water loop storage (Extended Length) ^(d)	(gal)	n/a	211.5 (217.5)	211.5 (217.5)	211.5 (217.5)	211.5 (217.5)	211.5 (217.5)	211.5 (217.5)	211.5 (217.5)	211.5 (217.5)	211.5 (217.5)	211.5 (217.5)	211.5 (217.5)	211.5 (217.5)	
	(l)	n/a	800.7 (823.2)	800.7 (823.2)	800.7 (823.2)	800.7 (823.2)	800.7 (823.2)	800.7 (823.2)	800.7 (823.2)	800.7 (823.2)	800.7 (823.2)	800.7 (823.2)	800.7 (823.2)	800.7 (823.2)	
Free-Cooling Chiller internal glycol volume (Extended Length) ^(d)	(gal)	n/a	n/a	n/a	n/a	n/a	n/a	n/a	258 (263)	n/a	258 (263)	n/a	258 (263)	301 (307)	
	(l)	n/a	n/a	n/a	n/a	n/a	n/a	n/a	977 (997)	n/a	977 (997)	n/a	977 (997)	1141 (1161)	
Customer Side Pump															
Pump Package Option (model number digit 40) ^(e)		n/a	5	6	7	5	6	7	5	6	7	5	6	7	5
Pump HP		n/a	50	60	75	50	60	75	50	60	75	50	60	75	50
Customer Water Connection Size ^(b)	(in)	n/a	6	8	8	6	8	8	6	8	8	6	8	8	6
	(mm)	n/a	150	200	200	150	200	200	150	200	200	150	200	200	150
Additional Water Storage in Pump System	(gal)	n/a	117	148	151	117	148	151	117	148	151	117	148	151	117
	(l)	n/a	443	560	572	443	560	572	443	560	572	443	560	572	443
UAPP Ambient Starting Temperatures															
Standard Ambient	°F (°C)	32 to 105 (0 to 40.6)													
Low Ambient	°F (°C)	0 to 105 (-17.7 to 40.6)													
Extreme Low Ambient	°F (°C)	-20 to 105 (-26.1 to 40.6)													
High Ambient	°F (°C)	32 to 125 (0 to 52)													
Wide Ambient	°F (°C)	0 to 125 (-17.7 to 52)													
General Unit															
Refrigerant		HFC-134a													
Refrigerant Ckts	#	2													
Minimum Load	%	15													
Refrigerant Charge/ckt	(lbs)	325													
	(kg)	148													
Oil		Trane OIL00311													

Table 2. General data — 300 tons units (continued)

Unit Size (tons)		300	
Condenser Length ^(a)		7V	8V
Oil Charge/ckt	(gal)	4	4
	(L)	15.1	15.1

^(a) Condenser length defined by model number digit 25: 7V = D; 8V = E.

^(b) Inlet and outlet sizing changes with options. Free cooling pipe sizes override evaporator sizes and pumps sizes override all options.

^(c) Direct Free Cooling defined by model number digit 42: T = TDFC; H = DFCE; F = DFCE; E = DFCE.

^(d) Extended Length is required for voltages 200V, 230V, 575V (model number digit 9 = A, B, F) and harmonic filtration (model number digit 44 = L).

^(e) Pump Package defined by model number digit 40 = 5, 6, 7.



General Information

Table 3. General data — unit larger than 300 tons

Unit Size (tons)	375	380	440	450	500	550
Condenser Length^(a)	9V	11V	9V	11V	11V	11V
Compressor Model (ckt 1/2)	CHSS-120 / CHSS	CHSS-120 / CHSS	CHSS-120 / CHSS	CHSS-120 / CHSS	CHSS-120 / CHSS	CHSS-120 / CHSS
Quantity (ckt 1/2)	#	2 / 1	2 / 1	2 / 1	2 / 2	2 / 2
Evaporator						
Water Storage	(gal)	36.3	39.5	39.5	45.0	49.3
	(L)	137.3	149.6	149.6	170.3	186.8
1 Pass arrangement						
Evap Water Connection Size ^(b)	(in)	8	8	8	8	8
	(mm)	200	200	200	200	200
Minimum Flow ^(c)	(gpm)	398	398	450	450	591
	(l/s)	25.1	25.1	28.4	28	37.3
Maximum Flow ^(c)	(gpm)	1750	1750	1981	1981	2603
	(l/s)	110.4	110.4	125.0	125	164.2
2 Pass arrangement						
Evap Water Connection Size ^(b)	(in)	8	8	8	8	8
	(mm)	200	200	200	200	200
Minimum Flow ^(c)	(gpm)	198	198	224	224	294
	(l/s)	12.5	12.5	14.0	14.1	18.5
Maximum Flow ^(c)	(gpm)	871	871	986	986	1295
	(l/s)	55.0	55.0	62.2	62.2	81.7
Condenser						
Quantity of Coils (ckt 1/2)		12 / 6	14 / 8	14 / 8	12 / 10	12 / 10
Coil Length	(in)	78.22	78.22	78.22	78.22	78.22
	(mm)	1987	1987	1987	1987	1987
Coil Height	(in)	49	49	49	49	49
	(mm)	1252	1252	1252	1252	1252
Fins/Ft		276	276	276	276	276
Quantity of Fans (ckt 1/2)	#	12 / 6	14 / 8	14 / 8	12 / 10	12 / 10
Free-Cooling^(d)						
Customer Water Connection Size	(in)	n/a	8.0	n/a	8.0	8.0
	(mm)	n/a	203.0	n/a	203.0	203.0
Qty of Coils Ckt 1		n/a	13.0	n/a	10	10
Qty of Coils Ckt 2		n/a	7.0	n/a	10	10

Table 3. General data — unit larger than 300 tons (continued)

Unit Size (tons)	375	380	440	450	500	550
Condenser Length^(a)	9V	11V	9V	11V	11V	11V
Coil Length (in)	n/a	72.49	n/a	72.49	72.49	72.49
Coil Length (mm)	n/a	1841	n/a	1841	1841	1841
Coil Height (in)	n/a	40	n/a	40	40	40
Coil Height (mm)	n/a	1016	n/a	1016	1016	1016
Fins/Ft	n/a	192	n/a	192	192	192
Rows	n/a	3	n/a	3	3	3
Glycol Storage Volume (gal)	n/a	231.9	n/a	231.9	231.9	231.9
Glycol Storage Volume (l)	n/a	878.2	n/a	878.2	878.2	878.2
Ambient Temperature Range						
Standard Ambient °F (°C)	32 to 105 (0 to 40.6)					
Low Ambient °F (°C)	0 to 105 (-17.7 to 40.6)					
Extreme Low Ambient °F (°C)	-15 to 105 (-26.1 to 40.6)					
High Ambient °F (°C)	32 to 125 (0 to 52)					
Wide Ambient °F (°C)	0 to 125 (-17.7 to 52)					
General Unit						
Refrigerant	HFC-134a					
Refrigerant Ckts	2					
Minimum Load	15%	15%	15%	15%	10%	10%
Refrigerant Charge (ckt 1/2)	305 / 143	322 / 160	305 / 143	328 / 163	294 / 265	300 / 270
	138 / 65	146 / 73	138 / 65	149 / 74	133 / 120	136 / 122
Oil	OIL00311					
Oil Charge (ckt 1/2)	5.8 / 4.0	5.8 / 4.0	5.8 / 4.0	5.8 / 4.0	5.8 / 5.8	5.8 / 5.8
	22.0 / 15.1	22.0 / 15.1	22.0 / 15.1	22.0 / 15.1	22.0 / 22.0	22.0 / 22.0

(a) Condenser length defined by model number digit 25; 4V = A; 5V = B; 6V = C; 7V = D; 8V = E; 9V = F; 11V = H

(b) Sizes are for units without free-cooling option (model number digit 42 = X).

(c) Minimum and maximum flow rates apply to constant-flow chilled water systems running at AHRI conditions, without freeze inhibitors added to the water loop.

(d) Units with free-cooling option are indicated by model number digit 42 = T.



Controls

Symbio™ 800 Controller

Trane Ascend™ chillers offer predictive controls that anticipate and compensate for load changes. Other strategies made possible with the Symbio™ 800 controls are:

Feedforward Adaptive Control

Feedforward is an open-loop, predictive control strategy designed to anticipate and compensate for load changes. It uses evaporator entering-water temperature as an indication of load change. This allows the controller to respond faster and maintain stable leaving-water temperatures.

Soft Loading

The chiller controller uses soft loading except during manual operation. Large adjustments to setpoint changes are made gradually, preventing the compressor from cycling unnecessarily. It does this by internally filtering the setpoints to avoid reaching the differential-to-stop or the demand limit. Soft loading applies to the leaving chilled-water temperature and demand limit setpoints.

Adaptive Controls

Adaptive Controls directly sense the control variables that govern the operation of the chiller: evaporator pressure and condenser pressure. When any one of these variables approaches a limit condition when damage may occur to the unit or shutdown on a safety, Adaptive Controls takes corrective action to avoid shutdown and keep the chiller operating. This happens through combined actions of compressor and/or fan staging. Whenever possible, the chiller is allowed to continue making chilled water. This keeps cooling capacity available until the problem can be solved. Overall, the safety controls help keep the building or process running and out of trouble.

Integrated Rapid Restart

Rapid Restart™ is available on unit sizes larger than 300 tons.

Bringing a chiller back online rapidly after a loss of power is critical to operations in mission critical environments like data centers and hospitals which demand the highest levels of reliability.

A loss of cooling capacity can be costly, which is why Trane chillers are designed and engineered for Rapid Restart™. In the event of a power interruption, the chiller will start a compressor before the front panel display is fully powered up eliminating the need for UPS. This not only helps the chiller get back online faster, but it also provides a simple and reliable solution to minimize the risks of financially devastating damage to assets caused by overheating due to a power loss.

Of course, the truest test of a chiller's restart capabilities is the amount of time it takes to resume full-load cooling, and this is where the chiller really shines. An 80 percent cooling load can be achieved in less than 2.5 minutes after power restoration—your assurance that the cooling capacity your equipment requires is just a few minutes away.

Rapid Restart Test

After completion of a standard full load witness test, power to the chiller will be cut and then reapplied to demonstrate the chiller's rapid restart capabilities for disaster relief.

AdaptiSpeed Control

Compressor speed is used to control capacity of the chiller, optimizing mathematically with the condenser fan speed to provide the highest level of performance. The increased performance of the controller allows the chiller to operate longer at higher efficiency, and with greater stability.

Tracer AdaptiView TD7 Operator Interface

The standard Tracer® AdaptiView™ TD7 display provided with the Symbio™ 800 controller features a 7" LCD touch-screen, allowing access to all operational inputs and outputs. This is an

advanced interface that allows the user to access any important information concerning setpoints, active temperatures, modes, electrical data, pressure, and diagnostics. It uses full text display available in 26 languages.

Display Features Include:

- LCD touch-screen with LED backlighting, for scrolling access to input and output operating information
- Single-screen, folder/tab-style display of all available information on individual components (evaporator, condenser, compressor, etc.)
- Manual override indication
- Password entry/lockout system to enable or disable display
- Automatic and immediate stop capabilities for standard or immediate manual shutdown
- Fast, easy access to available chiller data in tabbed format, including:
 - Easy to view Operating Modes
 - Logical Sub-Component Reports:
 - Evaporator
 - Condenser
 - Compressor
 - Motor
 - 3 User Programmable Custom Reports
 - ASHRAE report
 - Log Sheet Report
 - Alarms Report
 - 8 pre-defined Standard Graphs
 - 4 User Programmable Custom Graphs
 - Unit Settings
 - Feature Settings
 - Water Reset
 - Manual Control Settings
 - Globalization Settings
 - Support of 27 languages
 - Brightness Setting
 - Cleaning Mode

System Integration

Stand-Alone Controls

Single chillers installed in applications without a building management system are simple to install and control: only a remote auto/stop for scheduling is required for unit operation. Signals from the chilled-water pump contactor auxiliary, or a flow switch, are wired to the chilled-water flow interlock. Signals from a time clock or some other remote device are wired to the external auto/stop input.

- Auto/Stop - A job-site provided contact closure turns the unit on and off.
- Emergency Stop - A job-site provided contact opening wired to this input turns the unit off and requires a manual reset of the unit microcomputer. This closure is typically triggered by a job-site provided system such as a fire alarm.



Hardwire Points

Microcomputer controls allow simple interface with other control systems, such as time clocks, building automation systems, and ice storage systems via hardwire points. This means you have the flexibility to meet job requirements while not having to learn a complicated control system.

Remote devices are wired from the control panel to provide auxiliary control to a building automation system. Inputs and outputs can be communicated via a typical 4–20 mA electrical signal, an equivalent 2–10 Vdc signal, or by utilizing contact closures.

This setup has the same features as a stand-alone water chiller, with the possibility of having additional optional features:

- Ice making control
- External chilled water setpoint, external demand limit setpoint
- Chilled water temperature reset
- Programmable relays - available outputs are: alarm-latching, alarm-auto reset, general alarm-warning, chiller limit mode, compressor running, and Tracer control.

Tracer SC

The Tracer® SC system controller acts as the central coordinator for all individual equipment devices on a Tracer building automation system. The TracerSC scans all unit controllers to update information and coordinate building control, including building subsystems such as VAV and chiller water systems. With this system option, the full breadth of Trane’s HVAC and controls experience are applied to offer solutions to many facility issues. The LAN allows building operators to manage these varied components as one system from any personal computer with web access. The benefits of this system are:

- Improved usability with automatic data collection, enhanced data logging, easier to create graphics, simpler navigation, pre-programmed scheduling, reporting, and alarm logs.
- Flexible technology allows for system sizes from 30 to 120 unit controllers with any combination of LonTalk® or BACnet® unit controllers.
- LEED certification through site commissioning report, energy data collection measurement, optimizing energy performance, and maintaining indoor air quality.

Energy savings programs include: fan pressure optimization, ventilation reset, and chiller plant control (adds and subtracts chillers to meet cooling loads).

Symbio 800 Controls

Overview

The Symbio™ 800 controller is a factory-installed, application specific and programmable controller designed to control chillers and large packaged HVAC equipment. A 7-inch user interface features a touch-sensitive color screen that provides facility managers at-a-glance operating status, performance monitoring, scheduling changes, and operating adjustments. Other advanced features include automated controller back-up, and optional features such as secure remote connectivity, wireless building communications, mobile device connectivity, and custom programming with expandable I/O.

Symbio™ 800 Advantages		Benefits
Connected	Convenient, on-the-go access to advanced monitoring, troubleshooting, and energy management	<ul style="list-style-type: none"> • Minimum first cost • Maximum comfort • Minimized downtime • Minimum operating costs • Superior building and occupant productivity
Flexible	Minimized installation hardware and labor costs – able to use existing devices for maximum convenience, lower controls upgrades and relocation	
Reliable	Maximum equipment uptime and life, minimized maintenance and troubleshooting cost	

Features and Benefits

Symbio™ 800 Feature	Benefits
Multiple, open standard protocol support <ul style="list-style-type: none"> BACnet TP BACnet/IP LON (Optional) Modbus 	Simplified, lower cost, and more flexible integration with all common open standard protocols using Trane or competitive BAS systems and controllers
Remote connection to building or equipment	Trane Connect™ provides an easy, secure option to connect remotely to a Tracer SC+ or directly to your Trane equipment
Common integration strategies and equipment specific points lists	Simplified, lower cost, and uncompromised integration
Application specific and configurable	Reduced project costs with superior reliability, comfort, performance - applications specific and configurable system ensures machine continues to run within operating envelope. Ability to upgrade firmware with a simple file transfer.
Smart Analytics	Smart analytics provide superior reliability through the life of the equipment with minimum downtime
Data logging	Standard, local or remote Intuitive review and analysis of equipment, zone, and building performance
Local scheduling	Capable of operating in stand-alone operation without a building automation system as a temporary back-up schedule for ongoing comfort and energy savings
Rugged, 7-inch color touch screen user interface	Easy, touch navigation for viewing data and making operational changes
Display preferences	Choose how to view dates, times, units (SI, IP), screen brightness, data format, and backlight timeout. A total of 27 built-in languages are supported and selectable for all TD7 screens.
Intuitive navigation	Helps operators access data and alarms for quick and accurate response and resolution
At-a-glance status	Easily readable color display showing key operating parameters of major equipment components
Reports	Quickly summarizes data for clear understanding and interpretation to enable local monitoring of expected performance and operating efficiency
Graphs	Easily visualize trend data for local troubleshooting and fine-tuning
Multiple language support	Suitable for operation in multiple geographies
Adaptive Control™ Algorithms	Pre-empts potential equipment disruptions during rapidly changing conditions - providing consistent equipment performance and building comfort
SD card backup/restore	Faster, lower cost repairs with reduced downtime
Modbus device support	Capable of integrating optional Modbus devices for local or remote diagnostics — provides faster, lower cost troubleshooting and increased equipment performance

Options

Symbio™ 800 Feature	Benefits
Remote connection to building or equipment	Trane Connect™ provides an easy, secure option to connect remotely to a Tracer SC+ or directly to your Trane equipment
Programmable	Equipment application flexibility and cost-reduced control of nearby equipment
Expandable I/O	Field or factory installed I/O for programmable feature for reduced installation costs and increased installation flexibility
User security with audit trail support	Flexible and secure access for multiple users allows monitoring, overriding/releasing points, release of all overrides, custom report editing, and tracking changes by user
LonTalk	



Building Automation Systems

BACnet Building Automation Control Network

The BACnet® control network for Symbio® 800 expands communications from the unit UCM network to the Tracer® Ensemble™ or Tracer SC+ building automation system or third party building automation system. Utilizing BACnet, the BAS allows external setpoint and configuration adjustment and monitoring of status and diagnostics. The Symbio 800 utilizes the BACnet defined TP protocol as defined in ASHRAE standard 135-2004. This controller works in standalone mode, with Tracer® Ensemble™, Tracer SC+ or when connected to a third party building automation system that supports BACnet.

Modbus Automation Control Network

Allows the user to easily interface with Modbus™ RTU communication protocol via a single twisted pair wiring from the Symbio 800 controller to a factory installed device.

LonTalk Building Automation Systems

The LonTalk® communication protocol for the Symbio™ 800 controller expands communications from the unit UCM network to a Tracer® Ensemble™ building automation system or third party building automation system. Utilizing LonTalk®, the BAS allows external setpoint and configuration adjustment and monitoring of status and diagnostics. The Symbio™ 800 utilizes an FTT-10A free topology transceiver, which supports non-polarity sensitive, free topology wiring—which in turn allows the system installer to utilize star, bus, and loop architectures. This controller works in standalone mode, peer-to-peer with one or more other units, or when connected to a Tracer® Ensemble™, Tracer SC+, or a third party building automation system that supports LonTalk®.

Specifications

Controller Specifications	
Input power	24 Vdc +/- 10%, 400mA max
Storage temperature	-67°F to 185°F (-55°C to 85°C), Humidity: Between 5% to 100% (Condensing)
Operating temperature	-40°F to 158°F (-40°C to 70°C)
Environmental rating (enclosure)	IP3x
Time clock	On-board real time clock with 10 year battery backup
Mounting weight	Mounting surface must support 1.3 lb. (0.6 kg)
Overall dimensions	5.65 in. (143.5 mm) wide x 4.00 in. (101.6 mm) high x 2.17 in. (55 mm) deep
Agency Compliance	
<ul style="list-style-type: none"> • UL916 PAZX, Open Energy Management Equipment • UL94-5V Flammability • CE • FCC Part 15, Subpart B, Class B Limit • BTL Listed—Advanced Application Profile (B-AAC) 	
User Interface Specifications	
Input power	24 Vac +/- 10%, 21 VA, 50, or 60 Hz
Storage temperature	-67°F to 203°F (-55°C to 95°C), Humidity: Between 5% to 100% (Condensing)
Operating temperature	-40°F to 158°F (-40°C to 70°C), Humidity: Between 5% to 100% (Condensing)
Environmental rating (enclosure)	IP56 (dust and strong water jet protected) with optional sealed Ethernet cable (PN: X19070632020)
Mounting weight	Mounting surface must support 1.6 lb. (0.74 kg)
Overall dimensions	8.3 in. (211.6 mm) wide x 6.3 in. (158.8 mm) high x 2.1 in. (53.2 mm) deep [bezel depth 0.4 in. (11.3 mm)]

Agency Compliance

- UL916 PAZX, Open Energy Management Equipment
- UL94-5V, Flammability
- FCC CFR Title 47, Part 15.109: Class A Limit, (30 MHz—4 GHz)
- CE EMC Directive 2004/108/EC

Integrated Comfort System (ICS)

The onboard chiller controller is designed to be able to communicate with a wide range of building automation systems. In order to take full advantage of chiller's capabilities, incorporate your chiller into a Tracer® SC building automation system.

But the benefits do not stop at the chiller plant. At Trane, we realize that all the energy used in your cooling system is important. That is why we worked closely with other equipment manufacturers to predict the energy required by the entire system. We used this information to create patented control logic for optimizing HVAC system efficiency.

The building owners challenge is to tie components and applications expertise into a single reliable system that provides maximum comfort, control, and efficiency. Trane® Integrated Comfort systems (ICS) are a concept that combines system components, controls, and engineering applications expertise into a single, logical, and efficient system. These advanced controls are fully commissioned and available on every piece of Trane equipment, from the largest chiller to the smallest VAV box. As a manufacturer, only Trane offers this universe of equipment, controls, and factory installation and verification.



Electrical

Electrical Data

Table 4. Electrical data - 150 to 300 tons, 60Hz

Unit Size	Cond Length ^(a)	Rated Voltage ^(b)	AFD Input Amps ^(c)		Fans			Control VA ^(d)		MCA ^(e)	MOP ^(f)
			Comp A	Comp B	Qty ^(g)	kW	FLA ^(h)	Without Harmonic Filtration ⁽ⁱ⁾	With Harmonic Filtration ⁽ⁱ⁾		
150	4V	200	111	111	8	2.05	2.7	1394	n/a	632	800
		230	111	111	8	2.05	2.7	1394	n/a	550	700
		380	135	135	8	2.05	3.3	894	1394	334	450
		400	128	128	8	2.05	3.1	894	1394	317	400
		460	111	111	8	2.05	2.7	894	1394	275	350
		575	111	111	8	2.05	2.7	1394	n/a	220	300
165	4V	200	115	115	8	2.05	2.7	1394	n/a	652	800
		230	115	115	8	2.05	2.7	1394	n/a	567	700
		380	139	139	8	2.05	3.3	894	1394	343	450
		400	132	132	8	2.05	3.1	894	1394	325	450
		460	115	115	8	2.05	2.7	894	1394	284	350
		575	115	115	8	2.05	2.7	1394	n/a	227	300
165	5V	200	117	117	10	2.05	2.7	1394	n/a	675	800
		230	117	117	10	2.05	2.7	1394	n/a	587	800
		380	141	141	10	2.05	3.3	894	1394	355	450
		400	134	134	10	2.05	3.1	894	1394	337	450
		460	117	117	10	2.05	2.7	894	1394	294	400
		575	117	117	10	2.05	2.7	1394	n/a	235	300
180	4V	200	129	129	8	2.05	2.7	1394	n/a	725	1000
		230	129	129	8	2.05	2.7	1394	n/a	630	800
		380	156	156	8	2.05	3.3	894	1394	381	500
		400	148	148	8	2.05	3.1	894	1394	361	500
		460	129	129	8	2.05	2.7	894	1394	315	400
		575	129	129	8	2.05	2.7	1394	n/a	252	350
180	5V	200	132	132	10	2.05	2.7	1394	n/a	753	1000
		230	132	132	10	2.05	2.7	1394	n/a	655	800
		380	159	159	10	2.05	3.3	894	1394	395	500
		400	151	151	10	2.05	3.1	894	1394	375	500
		460	132	132	10	2.05	2.7	894	1394	328	450
		575	132	132	10	2.05	2.7	1394	n/a	262	350
200	5V	200	136	136	10	2.05	2.7	1394	n/a	773	1000
		230	136	136	10	2.05	2.7	1394	n/a	672	800
		380	165	165	10	2.05	3.3	894	1394	408	500
		400	156	156	10	2.05	3.1	894	1394	386	500
		460	136	136	10	2.05	2.7	894	1394	336	450
		575	136	136	10	2.05	2.7	1394	n/a	269	350

Table 4. Electrical data - 150 to 300 tons, 60Hz (continued)

Unit Size	Cond Length ^(a)	Rated Voltage ^(b)	AFD Input Amps ^(c)		Fans			Control VA ^(d)		MCA ^(e)	MOP ^(f)
			Comp A	Comp B	Qty ^(g)	kW	FLA ^(h)	Without Harmonic Filtration ⁽ⁱ⁾	With Harmonic Filtration ^(j)		
200	6V	200	131	131	12	2.05	2.7	1394	n/a	760	1000
		230	131	131	12	2.05	2.7	1394	n/a	661	800
		380	159	159	12	2.05	3.3	894	1394	402	500
		400	151	151	12	2.05	3.1	894	1394	381	500
		460	131	131	12	2.05	2.7	894	1394	331	450
		575	131	131	12	2.05	2.7	1394	n/a	265	350
225	5V	200	166	166	10	2.05	2.7	1434	n/a	929	1200
		230	166	166	10	2.05	2.7	1434	n/a	807	1000
		380	201	201	10	2.05	3.3	894	1434	489	600
		400	191	191	10	2.05	3.1	894	1434	464	600
		460	166	166	10	2.05	2.7	894	1434	404	500
		575	166	166	10	2.05	2.7	1434	n/a	323	450
225	6V	200	160	160	12	2.05	2.7	1434	n/a	910	1200
		230	160	160	12	2.05	2.7	1434	n/a	792	1000
		380	193	193	12	2.05	3.3	894	1434	478	600
		400	183	183	12	2.05	3.1	894	1434	453	600
		460	160	160	12	2.05	2.7	894	1434	396	500
		575	160	160	12	2.05	2.7	1434	n/a	317	400
250	5V	200	182	182	10	2.05	2.7	1434	n/a	1011	1200
		230	182	182	10	2.05	2.7	1434	n/a	879	1200
		380	220	220	10	2.05	3.3	894	1434	532	700
		400	209	209	10	2.05	3.1	894	1434	505	700
		460	182	182	10	2.05	2.7	894	1434	440	600
		575	182	182	10	2.05	2.7	1434	n/a	352	450
250	6V	200	168	168	12	2.05	2.7	1434	n/a	952	1200
		230	168	168	12	2.05	2.7	1434	n/a	828	1000
		380	204	204	12	2.05	3.3	894	1434	503	700
		400	194	194	12	2.05	3.1	894	1434	478	600
		460	168	168	12	2.05	2.7	894	1434	414	500
		575	168	168	12	2.05	2.7	1434	n/a	331	450
275	6V	200	196	196	12	2.05	2.7	1434	n/a	1096	1200
		230	196	196	12	2.05	2.7	1434	n/a	953	1200
		380	237	237	12	2.05	3.3	894	1434	577	800
		400	225	225	12	2.05	3.1	894	1434	547	700
		460	196	196	12	2.05	2.7	894	1434	477	600
		575	196	196	12	2.05	2.7	1434	n/a	381	500



Electrical

Table 4. Electrical data - 150 to 300 tons, 60Hz (continued)

Unit Size	Cond Length ^(a)	Rated Voltage ^(b)	AFD Input Amps ^(c)		Fans			Control VA ^(d)		MCA ^(e)	MOP ^(f)
			Comp A	Comp B	Qty ^(g)	kW	FLA ^(h)	Without Harmonic Filtration ⁽ⁱ⁾	With Harmonic Filtration ^(j)		
275	7V	200	202	202	14	2.05	2.7	1434	n/a	1140	1600
		230	202	202	14	2.05	2.7	1434	n/a	991	1200
		380	246	246	14	2.05	3.3	894	1434	604	800
		400	234	234	14	2.05	3.1	894	1434	574	800
		460	202	202	14	2.05	2.7	894	1434	496	600
		575	202	202	14	2.05	2.7	1434	n/a	396	500
300	7V	200	209	209	14	2.05	2.7	1434	n/a	1176	1600
		230	209	209	14	2.05	2.7	1434	n/a	1023	1200
		380	253	253	14	2.05	3.3	894	1434	619	800
		400	240	240	14	2.05	3.1	894	1434	587	800
		460	209	209	14	2.05	2.7	894	1434	511	700
		575	209	209	14	2.05	2.7	1434	n/a	409	500
300	8V	200	200	200	16	2.05	2.7	1434	n/a	1142	1600
		230	200	200	16	2.05	2.7	1434	n/a	993	1200
		380	242	242	16	2.05	3.3	894	1434	602	800
		400	230	230	16	2.05	3.1	894	1434	571	800
		460	200	200	16	2.05	2.7	894	1434	497	600
		575	200	200	16	2.05	2.7	1434	n/a	398	500

- ^(a) Condenser length defined by model number digit 25: 4V = A; 5V = B; 6V = C; 7V = D; 8V = E
- ^(b) Voltage Utilization Range: +/- 10% of Rated voltage (use range): 200/60/3 (180-220), 230/60/3 (208-254), 380/60/3 (342-418), 400/60/3 (360-440), 460/50/3 (360-440), 460/60/3 (414-506), 575/60/3 (516-633)
- ^(c) All 200, 230 and 575V units consist of a voltage autotransformer with a 460V unit downstream. As a result, AFD input amp draws for these voltages are the same as those of a corresponding 460V unit.
- ^(d) Control VA includes operational controls only. It does not include evaporator heaters. A separate 115/60/1, 15 amp customer provided power connection is required to power the evaporator heaters (150T-165T; 800 watts, 180T-300T; 1200 watts).
- ^(e) MCA - Minimum Circuit Ampacity - 125 percent of largest compressor VFD input plus 100 percent of all other loads for 380V, 400V, and 460V incoming voltage. All other voltages need to have the 460V calculation reflected to the appropriate voltage.
- ^(f) Max fuse or MOP = 225 percent of largest compressor VFD input plus 100 percent of second compressor VFD input, plus sum of condenser fan FLA.
- ^(g) Number of fans is evenly distributed between the two chiller circuits.
- ^(h) FLA values listed are the maximum possible. Some unit configurations may have lower FLA values.
- ⁽ⁱ⁾ Model number digit 44 = X.
- ^(j) Model number digit 44 = L.

Table 5. Electrical data - 150 to 300 tons, 50Hz

Unit Size	Cond Length ^(a)	Rated Voltage ^(b)	AFD Input Amps ^(c)		Fans			Control VA ^(d)		MCA ^(e)	MOP ^(f)
			Comp A	Comp B	Qty ^(g)	kW	FLA ^(h)	Without Harmonic Filtration ⁽ⁱ⁾	With Harmonic Filtration ^(j)		
150	4V	380	135	135	8	2.05	3.3	894	1394	334	450
		400	128	128	8	2.05	3.1	894	1394	317	400
165	4V	380	139	139	8	2.05	3.3	894	1394	343	450
		400	132	132	8	2.05	3.1	894	1394	325	450
165	5V	380	141	141	10	2.05	3.3	894	1394	355	450
		400	134	134	10	2.05	3.1	894	1394	337	450
180	4V	380	156	156	8	2.05	3.3	894	1394	381	500
		400	148	148	8	2.05	3.1	894	1394	361	500
180	5V	380	159	159	10	2.05	3.3	894	1394	395	500
		400	151	151	10	2.05	3.1	894	1394	375	500
200	5V	380	165	165	10	2.05	3.3	894	1394	408	500
		400	156	156	10	2.05	3.1	894	1394	386	500
200	6V	380	159	159	12	2.05	3.3	894	1394	402	500
		400	151	151	12	2.05	3.1	894	1394	381	500
225	5V	380	201	201	10	2.05	3.3	934	1434	489	600
		400	191	191	10	2.05	3.1	934	1434	464	600
225	6V	380	193	193	12	2.05	3.3	934	1434	478	600
		400	183	183	12	2.05	3.1	934	1434	453	600
250	5V	380	220	220	10	2.05	3.3	934	1434	532	700
		400	209	209	10	2.05	3.1	934	1434	505	700
250	6V	380	204	204	12	2.05	3.3	934	1434	503	700
		400	194	194	12	2.05	3.1	934	1434	478	600
275	6V	380	237	237	12	2.05	3.3	934	1434	577	800
		400	225	225	12	2.05	3.1	934	1434	547	700
275	7V	380	246	246	14	2.05	3.3	934	1434	604	800
		400	234	234	14	2.05	3.1	934	1434	574	800
300	7V	380	253	253	14	2.05	3.3	934	1434	619	800
		400	240	240	14	2.05	3.1	934	1434	587	800
300	8V	380	242	242	16	2.05	3.3	934	1434	602	800
		400	230	230	16	2.05	3.1	934	1434	571	800

- (a) Condenser length defined by model number digit 25: 4V = A; 5V = B; 6V = C; 7V = D; 8V = E
- (b) Voltage Utilization Range: +/- 10% of Rated voltage (use range): 200/60/3 (180-220), 230/60/3 (208-254), 380/60/3 (342-418), 400/60/3 (360-440), 400/50/3 (360-440), 460/60/3 (414-506), 575/60/3 (516-633)
- (c) All 200, 230 and 575V units consist of a voltage autotransformer with a 460V unit downstream. As a result, AFD input amp draws for these voltages are the same as those of a corresponding 460V unit.
- (d) Control VA includes operational controls only. It does not include evaporator heaters. A separate 115/60/1, 15 amp customer provided power connection is required to power the evaporator heaters (150T-165T; 800 watts, 180T-300T; 1200 watts).
- (e) MCA - Minimum Circuit Ampacity - 125 percent of largest compressor VFD input plus 100 percent of all other loads for 380V, 400V, and 460V incoming voltage. All other voltages need to have the 460V calculation reflected to the appropriate voltage.
- (f) Max fuse or MOP = 225 percent of largest compressor VFD input plus 100 percent of second compressor VFD input, plus sum of condenser fan FLA.
- (g) Number of fans is evenly distributed between the two chiller circuits.
- (h) FLA values listed are the maximum possible. Some unit configurations may have lower FLA values.
- (i) Model number digit 44 = X.
- (j) Model number digit 44 = L.

Table 6. Electrical data - 300 tons, 60hz (direct or indirect free cooling units only)

Unit Size	Cond Length ^(a)	Rated Voltage ^(b)	AFD Input Amps		Fans			Control Power FLA		Unit Powered Outlet and Evaporator Water Box Heaters ^(c)	Indirect Free-Cooling Pump and Heater Transformer ^(d)	Evaporator Pump and Transformer ^(e)			MCA ^(f)	MOP ^(g)
			Comp A	Comp B	Qty ^(h)	kW	FLA	Control Power FLA				50HP	60HP	75HP		
								Without Harmonic Filtration ⁽ⁱ⁾	With Harmonic Filtration ^(j)							
300	8V	460	200	200	16	2.05	2.7	2.1		FLA	FLA	0	0	0	506	700
300	8V	460	200	200	16	2.05	2.7		3.2	10.9	0	0	0	0	507	700
300	8V	460	200	200	16	2.05	2.7	2.1		10.9	0	59	0	0	565	700
300	8V	460	200	200	16	2.05	2.7		3.2	10.9	0	59	0	0	566	700
300	8V	460	200	200	16	2.05	2.7	2.1		10.9	0	0	73	0	579	700
300	8V	460	200	200	16	2.05	2.7		3.2	10.9	0	0	73	0	580	700
300	8V	460	200	200	16	2.05	2.7	2.1		10.9	0	0	0	95	601	800
300	8V	460	200	200	16	2.05	2.7		3.2	10.9	0	0	0	95	602	800
300	8V	460	200	200	16	2.05	2.7	2.1		10.9	41.5	0	0	0	548	700
300	8V	460	200	200	16	2.05	2.7		3.2	10.9	41.5	0	0	0	549	700
300	10V	460	200	200	20	2.05	2.7	2.1		10.9	0	0	0	0	517	700
300	10V	460	200	200	20	2.05	2.7		3.2	10.9	0	0	0	0	518	700
300	10V	460	200	200	20	2.05	2.7	2.1		10.9	0	59	0	0	576	700
300	10V	460	200	200	20	2.05	2.7		3.2	10.9	0	59	0	0	577	700
300	10V	460	200	200	20	2.05	2.7	2.1		10.9	0	0	73	0	590	700
300	10V	460	200	200	20	2.05	2.7		3.2	10.9	0	0	73	0	591	700
300	10V	460	200	200	20	2.05	2.7	2.1		10.9	0	0	0	95	612	800
300	10V	460	200	200	20	2.05	2.7		3.2	10.9	0	0	0	95	613	800
300	10V	460	200	200	20	2.05	2.7	2.1		10.9	41.5	0	0	0	559	700
300	10V	460	200	200	20	2.05	2.7		3.2	10.9	41.5	0	0	0	560	700
300	10V	460	200	200	20	2.05	2.7	2.1		10.9	41.5	61.1	0	0	620	800
300	10V	460	200	200	20	2.05	2.7		3.2	10.9	41.5	61.1	0	0	621	800
300	10V	460	200	200	20	2.05	2.7	2.1		10.9	41.5	0	75.1	0	634	800
300	10V	460	200	200	20	2.05	2.7		3.2	10.9	41.5	0	75.1	0	635	800
300	10V	460	200	200	20	2.05	2.7	2.1		10.9	41.5	0	0	97.1	656	800
300	10V	460	200	200	20	2.05	2.7		3.2	10.9	41.5	0	0	97.1	657	800

(a) Condenser length defined by model number digit 25: 8V = E. If the unit has additional free cooling fans, digit 42: 10V = E or H.

(b) Voltage Utilization Range: +/- 10% of Rated voltage (use range): 460/60/3 (414-506)

(c) Incorporates a 5KVA transformer powered by the chiller to energize these features.

(d) Indirect free cooling units utilize a 30HP pump for glycol circulation and a 3KVA transformer to energize evaporator piping heaters in off cycle.

(e) Units with an evaporator pump may be 50, 60, or 75HP. Indirect free cooling units paired with this feature contain a 1KVA transformer for powering pipe heaters.

(f) MCA - Minimum Circuit Ampacity - 125 percent of largest compressor VFD input plus 100 percent of all other loads.

(g) MOP - Maximum Overcurrent Protection - 225 percent of largest compressor VFD input plus 100 percent of all other loads rounded down to the closest standard size.

(h) Number of fans is evenly distributed between the two chiller circuits. On units with 20 fans, four of them are dedicated to free cooling.

(i) Model number digit 44 = X.

(j) Model number digit 44 = L.

Table 7. Electrical data - units larger than 300 tons, 60Hz

Unit Size	Cond Length ^(a)	Rated Voltage ^(b)	VFD Amps ^(c)		YD Amps ^(d)		YD Locked Rotor Amps ^(e)		Circuit 1 Fans		Circuit 2 Fans	
			Comp 1A	Comp 2A	Comp 1B	Comp 2B	Comp 1B	Comp 2B	Qty	FLA	Qty	FLA
375	9-10V	380	253	242	238	-	424	-	12	3.3	6	3.3
		400	240	230	226	-	398	-	12	3.1	6	3.1
		460	206	197	197	-	346	-	12	2.7	6	2.7
		575	160	153	157	-	277	-	12	2.7	6	2.7
380	11V	380	245	228	238	-	424	-	14	3.3	8	3.3
		400	233	217	226	-	398	-	14	3.1	8	3.1
		460	200	186	196	-	346	-	14	2.7	8	2.7
		575	160	149	157	-	277	-	14	2.7	8	2.7
440	9-10V	380	305	303	246	-	424	-	12	3.3	6	3.3
		400	290	287	234	-	398	-	12	3.1	6	3.1
		460	250	248	203	-	346	-	12	2.7	6	2.7
		575	192	191	163	-	277	-	12	2.7	6	2.7
450	11V	380	302	284	246	-	424	-	14	3.3	8	3.3
		400	286	269	233	-	398	-	14	3.1	8	3.1
		460	247	232	203	-	346	-	14	2.7	8	2.7
		575	197	185	162	-	277	-	14	2.7	8	2.7
500	11V	380	277	295	251	262	424	424	12	3.3	10	3.3
		400	263	280	239	249	398	398	12	3.1	10	3.1
		460	226	241	208	216	346	346	12	2.7	10	2.7
		575	175	186	166	173	277	277	12	2.7	10	2.7
550	11V	380	318	340	257	269	424	424	12	3.3	10	3.3
		400	301	322	244	256	398	398	12	3.1	10	3.1
		460	260	278	212	222	346	346	12	2.7	10	2.7
		575	200	213	170	178	277	277	12	2.7	10	2.7

(a) Condenser length defined by model number digit 25: 9V = F; 10V = G; 11V = H.
 (b) Voltage Utilization Range: +/- 10% of Rated voltage (use range): 380/60/3 (342-418), 400/60/3 (360-440), 460/60/3 (414-506), 575/60/3 (516-633)
 (c) 575V units contain a voltage autotransformer with 460V distribution downstream of it. The amps listed are what the primary side of the autotransformer would be subject to from the VFD.
 (d) YD starter amps for compressor 1B and 2B. 375-450 ton units do not have a compressor 2B, as noted by the "-".
 (e) YD starter locked rotor amps in "wye" configuration.



Electrical

Table 8. Electrical data, MCA and MOP - units larger than 300 tons, 60Hz

Unit Size	Cond Length ^(a)	Rated Voltage ^(b)	Circuit 1 ^(c)		Circuit 2 ^(d)		Single Point Power ^(e)	
			MCA ^(f)	MOP ^(g)	MCA ^(f)	MOP ^(g)	MCA ^(f)	MOP ^(g)
375	9-10V	380	596	800	325	500	861	1000
		400	566	800	309	500	817	1000
		460	489	600	265	450	704	800
		575	393	500	211	350	565	700
380	11V	380	593	800	314	500	850	1000
		400	563	700	298	500	807	1000
		460	486	600	256	400	696	800
		575	398	500	211	350	572	700
440	9-10V	380	669	800	401	700	995	1200
		400	636	800	380	600	944	1200
		460	550	800	328	500	816	1000
		575	439	600	258	400	649	800
450	11V	380	672	800	384	600	985	1200
		400	636	800	363	600	932	1200
		460	552	700	314	500	807	1000
		575	449	600	256	400	659	800
500	11V	380	639	800	666	800	1232	1600
		400	607	800	632	800	1170	1200
		460	525	700	546	700	1011	1200
		575	420	500	436	600	810	1000
550	11V	380	697	1000	730	1000	1341	1600
		400	660	800	692	1000	1271	1600
		460	572	800	599	800	1101	1200
		575	456	600	474	600	877	1000

(a) Condenser length defined by model number digit 25: 9V = F; 10V = G; 11V = H.

(b) Voltage Utilization Range: +/- 10% of Rated voltage (use range): 380/60/3 (342-418), 400/60/3 (360-440), 460/60/3 (414-506), 575/60/3 (516-633)

(c) For units with dual point power, circuit 1 has the listed electrical statistics.

(d) For units with dual point power, circuit 2 has the listed electrical statistics.

(e) For units with a single point power connection, both circuits combined have the listed electrical statistics.

(f) MCA - Minimum Circuit Ampacity - 125 percent of largest compressor VFD input plus 100 percent of all other loads.

(g) MOP - Maximum Overcurrent Protection - 225 percent of largest compressor VFD input plus 100 percent of all other loads rounded down to the closest standard size.

Table 9. Electrical data - units larger than 300 tons, 50Hz

Unit Size	Cond Length ^(a)	Rated Voltage ^(b)	VFD Amps ^(c)		YD Amps ^(d)		YD Locked Rotor Amps ^(e)		Circuit 1 Fans		Circuit 2 Fans	
			Comp 1A	Comp 2A	Comp 1B	Comp 2B	Comp 1B	Comp 2B	Qty	FLA	Qty	FLA
375	9-10V	380	246	242	202	-	373	-	12	3.3	6	3.3
		400	233	230	191	-	354	-	12	3.1	6	3.1
380	11V	380	240	228	203	-	373	-	14	3.3	8	3.3
		400	228	217	193	-	354	-	14	3.1	8	3.1
440	9-10V	380	297	286	208	-	373	-	12	3.3	6	3.3
		400	281	271	197	-	354	-	12	3.1	6	3.1
450	11V	380	294	284	209	-	373	-	14	3.3	8	3.3
		400	279	269	198	-	354	-	14	3.1	8	3.1
500	11V	380	269	284	212	219	373	373	12	3.3	10	3.3
		400	256	270	202	208	354	354	12	3.1	10	3.1
550	11V	380	308	327	216	225	373	373	12	3.3	10	3.3
		400	292	311	206	214	354	354	12	3.1	10	3.1

- (a) Condenser length defined by model number digit 25: 9V = F; 10V = G; 11V = H.
- (b) Voltage Utilization Range: +/- 10% of Rated voltage (use range): 380/60/3 (342-418), 400/60/3 (360-440), 460/60/3 (414-506), 575/60/3 (516-633)
- (c) 575V units contain a voltage autotransformer with 460V distribution downstream of it. The amps listed are what the primary side of the autotransformer would be subject to from the VFD.
- (d) YD starter amps for compressor 1B and 2B. 375-450 ton units do not have a compressor 2B, as noted by the "-".
- (e) YD starter locked rotor amps in "wye" configuration.

Table 10. Electrical data, MCA and MOP - units larger than 300 tons, 50Hz

Unit Size	Cond Length ^(a)	Rated Voltage ^(b)	Circuit 1 ^(c)		Circuit 2 ^(d)		Single Point Power ^(e)	
			MCA ^(f)	MOP ^(g)	MCA ^(f)	MOP ^(g)	MCA ^(f)	MOP ^(g)
375	9-10V	380	552	700	325	500	816	1000
		400	522	700	309	500	773	1000
380	11V	380	552	700	314	500	809	1000
		400	524	700	298	500	768	800
440	9-10V	380	621	800	380	600	930	1200
		400	588	800	360	600	880	1000
450	11V	380	625	800	384	600	938	1200
		400	593	800	363	600	889	1000
500	11V	380	590	800	610	800	1129	1200
		400	562	800	579	800	1073	1200
550	11V	380	643	800	669	800	1231	1600
		400	611	800	636	800	1169	1200

- (a) Condenser length defined by model number digit 25: 9V = F; 10V = G; 11V = H.
- (b) Voltage Utilization Range: +/- 10% of Rated voltage (use range): 380/60/3 (342-418), 400/60/3 (360-440), 460/60/3 (414-506), 575/60/3 (516-633)
- (c) For units with dual point power, circuit 1 has the listed electrical statistics.
- (d) For units with dual point power, circuit 2 has the listed electrical statistics.
- (e) For units with a single point power connection, both circuits combined have the listed electrical statistics.
- (f) MCA - Minimum Circuit Ampacity - 125 percent of largest compressor VFD input plus 100 percent of all other loads.
- (g) MOP - Maximum Overcurrent Protection - 225 percent of largest compressor VFD input plus 100 percent of all other loads rounded down to the closest standard size.



Short Circuit Rating

Table 11. Short circuit rating (kA) - 150 to 300 ton units, 60Hz

Unit Size	Cond Length ^(a)	Rated Voltage	Terminal Block and Breaker	High Fault Circuit Breaker
150	4V	200	10	65
		230	10	65
		380	10	65
		400	10	65
		460	10	65
		575	10	25
165	4V	200	10	65
		230	10	65
		380	10	65
		400	10	65
		460	10	65
		575	10	25
165	5V	200	10	65
		230	10	65
		380	10	65
		400	10	65
		460	10	65
		575	10	25
180	4V	200	10	65
		230	10	65
		380	10	65
		400	10	65
		460	10	65
		575	10	25
180	5V	200	10	65
		230	10	65
		380	10	65
		400	10	65
		460	10	65
		575	10	25
200	5V	200	10	65
		230	10	65
		380	10	65
		400	10	65
		460	10	65
		575	10	25

Table 11. Short circuit rating (kA) - 150 to 300 ton units, 60Hz (continued)

Unit Size	Cond Length ^(a)	Rated Voltage	Terminal Block and Breaker	High Fault Circuit Breaker
200	6V	200	10	65
		230	10	65
		380	10	65
		400	10	65
		460	10	65
		575	10	25
225	5V	200	10	65
		230	10	65
		380	10	65
		400	10	65
		460	10	65
		575	10	25
225	6V	200	10	65
		230	10	65
		380	10	65
		400	10	65
		460	10	65
		575	10	25
250	5V	200	10	65
		230	10	65
		380	10	65
		400	10	65
		460	10	65
		575	10	25
250	6V	200	10	65
		230	10	65
		380	10	65
		400	10	65
		460	10	65
		575	10	25
275	6V	200	10	65
		230	10	65
		380	10	65
		400	10	65
		460	10	65
		575	10	25
275	7V	200	10	65
		230	10	65
		380	10	65
		400	10	65
		460	10	65
		575	10	25



Electrical

Table 11. Short circuit rating (kA) - 150 to 300 ton units, 60Hz (continued)

Unit Size	Cond Length ^(a)	Rated Voltage	Terminal Block and Breaker	High Fault Circuit Breaker
300	7V	200	10	65
		230	10	65
		380	10	65
		400	10	65
		460	10	65
		575	10	25
300	8V	200	10	65
		230	10	65
		380	10	65
		400	10	65
		460	10	65
		575	10	25
300	10V ^(b)	460	n/a	65

^(a) Condenser length defined by model number digit 25: 4V = A; 5V = B; 6V = C; 7V = D; 8V = E.

^(b) Extra free-cooling coils (condenser length) defined by model number digit 42: 10V = E or H.

Table 12. Short circuit rating (kA) - 150 to 300 ton units, 50Hz

Unit Size	Cond Length ^(a)	Rated Voltage	Terminal Block and Breaker	High Fault Circuit Breaker
150	4V	380	10	65
		400	10	65
165	4V	380	10	65
		400	10	65
165	5V	380	10	65
		400	10	65
180	4V	380	10	65
		400	10	65
180	5V	380	10	65
		400	10	65
200	5V	380	10	65
		400	10	65
200	6V	380	10	65
		400	10	65
225	5V	380	10	65
		400	10	65
225	6V	380	10	65
		400	10	65
250	5V	380	10	65
		400	10	65
250	6V	380	10	65
		400	10	65

Table 12. Short circuit rating (kA) - 150 to 300 ton units, 50Hz (continued)

Unit Size	Cond Length ^(a)	Rated Voltage	Terminal Block and Breaker	High Fault Circuit Breaker
275	6V	380	10	65
		400	10	65
275	7V	380	10	65
		400	10	65
300	7V	380	10	65
		400	10	65
300	8V	380	10	65
		400	10	65

^(a) Condenser length defined by model number digit 25: 4V = A; 5V = B; 6V = C; 7V = D; 8V = E

Table 13. Short circuit rating (kA) - units larger than 300 tons, 60Hz

Unit Size	Cond Length ^(a)	Rated Voltage	Dual Point Power			Single Point Power		
			Terminal Block	Ckt Breaker		Terminal Block	Ckt Breaker	
			Base Fault	Std Fault	High Fault	Base Fault	Std Fault	High Fault
375	9-10V	380	10	35	65	10	35	65
		400	10	35	65	10	35	65
		460	10	35	65	10	35	65
		575	10	18	25	10	18	25
380	11V	380	10	35	65	10	35	65
		400	10	35	65	10	35	65
		460	10	35	65	10	35	65
		575	10	18	25	10	18	25
440	9-10V	380	10	35	65	10	35	65
		400	10	35	65	10	35	65
		460	10	35	65	10	35	65
		575	10	18	25	10	18	25
450	11V	380	10	35	65	10	35	65
		400	10	35	65	10	35	65
		460	10	35	65	10	35	65
		575	10	18	25	10	18	25
500	11V	380	10	35	65	10	-	-
		400	10	35	65	10	-	-
		460	10	35	65	10	35	65
		575	10	18	25	10	18	25
550	11V	380	10	35	65	10	-	-
		400	10	35	65	10	-	-
		460	10	35	65	10	35	65
		575	10	18	25	10	18	25

^(a) Condenser length defined by model number digit 25: 9V = F; 10V = G; 11V = H.



Electrical

Table 14. Short circuit rating (kA) - units larger than 300 tons, 50Hz

Unit Size	Cond Length ^(a)	Rated Voltage	Dual Point Power			Single Point Power		
			Terminal Block	Ckt Breaker		Terminal Block	Ckt Breaker	
			Base Fault	Std Fault	High Fault	Base Fault	Std Fault	High Fault
375	9-10V	380	10	35	65	10	35	65
		400	10	35	65	10	35	65
380	11V	380	10	35	65	10	35	65
		400	10	35	65	10	35	65
440	9-10V	380	10	35	65	10	35	65
		400	10	35	65	10	35	65
450	11V	380	10	35	65	10	35	65
		400	10	35	65	10	35	65
500	11V	380	10	35	65	10	-	-
		400	10	35	65	10	-	-
550	11V	380	10	35	65	10	-	-
		400	10	35	65	10	-	-

^(a) Condenser length defined by model number digit 25: 9V = F; 10V = G; 11V = H.

Customer Wiring

Table 15. Customer wire selection - 150 to 300 tons, 60Hz

Unit Size	Cond Length ^(a)	Rated Voltage	Terminal Block	Circuit Breaker	Circuit Breaker (High Fault)
150	4V	200	n/a	(3) 3/0-500MCM	(3) 3/0-500MCM
		230	n/a	(3) 3/0-500MCM	(3) 3/0-500MCM
		380	(2) 4AWG-500MCM	(2) 2/0-500MCM	(2) 2/0-500MCM
		400	(2) 4AWG-500MCM	(2) 2/0-500MCM	(2) 2/0-500MCM
		460	(2) 4AWG-500MCM	(2) 2/0-500MCM	(2) 2/0-500MCM
		575	n/a	(3) 3/0-500MCM	(3) 3/0-500MCM
165	4V	200	n/a	(3) 3/0-500MCM	(3) 3/0-500MCM
		230	n/a	(3) 3/0-500MCM	(3) 3/0-500MCM
		380	(2) 4AWG-500MCM	(2) 2/0-500MCM	(2) 2/0-500MCM
		400	(2) 4AWG-500MCM	(2) 2/0-500MCM	(2) 2/0-500MCM
		460	(2) 4AWG-500MCM	(2) 2/0-500MCM	(2) 2/0-500MCM
		575	n/a	(3) 3/0-500MCM	(3) 3/0-500MCM
165	5V	200	n/a	(3) 3/0-500MCM	(3) 3/0-500MCM
		230	n/a	(3) 3/0-500MCM	(3) 3/0-500MCM
		380	(2) 4AWG-500MCM	(2) 2/0-500MCM	(2) 2/0-500MCM
		400	(2) 4AWG-500MCM	(2) 2/0-500MCM	(2) 2/0-500MCM
		460	(2) 4AWG-500MCM	(2) 2/0-500MCM	(2) 2/0-500MCM
		575	n/a	(3) 3/0-500MCM	(3) 3/0-500MCM
180	4V	200	n/a	(4) 3/0-500MCM	(4) 3/0-500MCM
		230	n/a	(3) 3/0-500MCM	(3) 3/0-500MCM
		380	(2) 4AWG-500MCM	(2) 2/0-500MCM	(2) 2/0-500MCM
		400	(2) 4AWG-500MCM	(2) 2/0-500MCM	(2) 2/0-500MCM
		460	(2) 4AWG-500MCM	(2) 2/0-500MCM	(2) 2/0-500MCM
		575	n/a	(3) 3/0-500MCM	(3) 3/0-500MCM
180	5V	200	n/a	(4) 3/0-500MCM	(4) 3/0-500MCM
		230	n/a	(3) 3/0-500MCM	(3) 3/0-500MCM
		380	(2) 4AWG-500MCM	(2) 2/0-500MCM	(2) 2/0-500MCM
		400	(2) 4AWG-500MCM	(2) 2/0-500MCM	(2) 2/0-500MCM
		460	(2) 4AWG-500MCM	(2) 2/0-500MCM	(2) 2/0-500MCM
		575	n/a	(3) 3/0-500MCM	(3) 3/0-500MCM
200	5V	200	n/a	(4) 3/0-500MCM	(4) 3/0-500MCM
		230	n/a	(3) 3/0-500MCM	(3) 3/0-500MCM
		380	(2) 4AWG-500MCM	(2) 2/0-500MCM	(2) 2/0-500MCM
		400	(2) 4AWG-500MCM	(2) 2/0-500MCM	(2) 2/0-500MCM
		460	(2) 4AWG-500MCM	(2) 2/0-500MCM	(2) 2/0-500MCM
		575	n/a	(3) 3/0-500MCM	(3) 3/0-500MCM
200	6V	200	n/a	(4) 3/0-500MCM	(4) 3/0-500MCM
		230	n/a	(3) 3/0-500MCM	(3) 3/0-500MCM
		380	(2) 4AWG-500MCM	(2) 2/0-500MCM	(2) 2/0-500MCM
		400	(2) 4AWG-500MCM	(2) 2/0-500MCM	(2) 2/0-500MCM
		460	(2) 4AWG-500MCM	(2) 2/0-500MCM	(2) 2/0-500MCM
		575	n/a	(3) 3/0-500MCM	(3) 3/0-500MCM



Electrical

Table 15. Customer wire selection - 150 to 300 tons, 60Hz (continued)

Unit Size	Cond Length ^(a)	Rated Voltage	Terminal Block	Circuit Breaker	Circuit Breaker (High Fault)
225	5V	200	n/a	(4) 3/0-500MCM	(4) 3/0-500MCM
		230	n/a	(4) 3/0-500MCM	(4) 3/0-500MCM
		380	(2) 4AWG-500MCM	(2) 2/0-500MCM	(2) 2/0-500MCM
		400	(2) 4AWG-500MCM	(2) 2/0-500MCM	(2) 2/0-500MCM
		460	(2) 4AWG-500MCM	(2) 2/0-500MCM	(2) 2/0-500MCM
		575	n/a	(3) 3/0-500MCM	(3) 3/0-500MCM
225	6V	200	n/a	(4) 3/0-500MCM	(4) 3/0-500MCM
		230	n/a	(4) 3/0-500MCM	(4) 3/0-500MCM
		380	(2) 4AWG-500MCM	(2) 2/0-500MCM	(2) 2/0-500MCM
		400	(2) 4AWG-500MCM	(2) 2/0-500MCM	(2) 2/0-500MCM
		460	(2) 4AWG-500MCM	(2) 2/0-500MCM	(2) 2/0-500MCM
		575	n/a	(3) 3/0-500MCM	(3) 3/0-500MCM
250	5V	200	n/a	(4) 3/0-500MCM	(4) 3/0-500MCM
		230	n/a	(4) 3/0-500MCM	(4) 3/0-500MCM
		380	(2) 4AWG-500MCM	(3) 3/0-500MCM	(3) 3/0-500MCM
		400	(2) 4AWG-500MCM	(3) 3/0-500MCM	(3) 3/0-500MCM
		460	(2) 4AWG-500MCM	(2) 2/0-500MCM	(2) 2/0-500MCM
		575	n/a	(3) 3/0-500MCM	(3) 3/0-500MCM
250	6V	200	n/a	(4) 3/0-500MCM	(4) 3/0-500MCM
		230	n/a	(4) 3/0-500MCM	(4) 3/0-500MCM
		380	(2) 4AWG-500MCM	(3) 3/0-500MCM	(3) 3/0-500MCM
		400	(2) 4AWG-500MCM	(2) 2/0-500MCM	(2) 2/0-500MCM
		460	(2) 4AWG-500MCM	(2) 2/0-500MCM	(2) 2/0-500MCM
		575	n/a	(3) 3/0-500MCM	(3) 3/0-500MCM
275	6V	200	n/a	(4) 3/0-500MCM	(4) 3/0-500MCM
		230	n/a	(4) 3/0-500MCM	(4) 3/0-500MCM
		380	(2) 4AWG-500MCM	(3) 3/0-500MCM	(3) 3/0-500MCM
		400	(2) 4AWG-500MCM	(3) 3/0-500MCM	(3) 3/0-500MCM
		460	(2) 4AWG-500MCM	(2) 2/0-500MCM	(2) 2/0-500MCM
		575	n/a	(3) 3/0-500MCM	(3) 3/0-500MCM
275	7V	200	n/a	(4) 3/0-500MCM	(4) 3/0-500MCM
		230	n/a	(4) 3/0-500MCM	(4) 3/0-500MCM
		380	(2) 4AWG-500MCM	(3) 3/0-500MCM	(3) 3/0-500MCM
		400	(2) 4AWG-500MCM	(3) 3/0-500MCM	(3) 3/0-500MCM
		460	(2) 4AWG-500MCM	(2) 2/0-500MCM	(2) 2/0-500MCM
		575	n/a	(3) 3/0-500MCM	(3) 3/0-500MCM
300	7V	200	n/a	(4) 3/0-500MCM	(4) 3/0-500MCM
		230	n/a	(4) 3/0-500MCM	(4) 3/0-500MCM
		380	(2) 4AWG-500MCM	(3) 3/0-500MCM	(3) 3/0-500MCM
		400	(2) 4AWG-500MCM	(3) 3/0-500MCM	(3) 3/0-500MCM
		460	(2) 4AWG-500MCM	(3) 3/0-500MCM	(3) 3/0-500MCM
		575	n/a	(3) 3/0-500MCM	(3) 3/0-500MCM

Table 15. Customer wire selection - 150 to 300 tons, 60Hz (continued)

Unit Size	Cond Length ^(a)	Rated Voltage	Terminal Block	Circuit Breaker	Circuit Breaker (High Fault)
300	8V	200	n/a	(4) 3/0-500MCM	(4) 3/0-500MCM
		230	n/a	(4) 3/0-500MCM	(4) 3/0-500MCM
		380	(2) 4AWG-500MCM	(3) 3/0-500MCM	(3) 3/0-500MCM
		400	(2) 4AWG-500MCM	(3) 3/0-500MCM	(3) 3/0-500MCM
		460	(2) 4AWG-500MCM	(2) 2/0-500MCM	(2) 2/0-500MCM
		575	n/a	(3) 3/0-500MCM	(3) 3/0-500MCM
300	10V ^(b)	460	n/a	n/a	(3) 3/0-500MCM

Note: Field wire insulation temperature rating must be minimum 90°C unless otherwise specified.

^(a) Condenser length defined by model number digit 25: 4V = A; 5V = B; 6V = C; 7V = D; 8V = E

^(b) Extra free-cooling coils (condenser length) defined by model number digit 42: 10V = E or H



Electrical

Table 16. Customer wire selection - 150 to 300 tons, 50Hz

Unit Size	Cond Length ^(a)	Rated Voltage	Terminal Block	Circuit Breaker	Circuit Breaker (High Fault)
150	4V	380	(2) 4AWG-500MCM	(2) 2/0-500MCM	(2) 2/0-500MCM
		400	(2) 4AWG-500MCM	(2) 2/0-500MCM	(2) 2/0-500MCM
165	4V	380	(2) 4AWG-500MCM	(2) 2/0-500MCM	(2) 2/0-500MCM
		400	(2) 4AWG-500MCM	(2) 2/0-500MCM	(2) 2/0-500MCM
165	5V	380	(2) 4AWG-500MCM	(2) 2/0-500MCM	(2) 2/0-500MCM
		400	(2) 4AWG-500MCM	(2) 2/0-500MCM	(2) 2/0-500MCM
180	4V	380	(2) 4AWG-500MCM	(2) 2/0-500MCM	(2) 2/0-500MCM
		400	(2) 4AWG-500MCM	(2) 2/0-500MCM	(2) 2/0-500MCM
180	5V	380	(2) 4AWG-500MCM	(2) 2/0-500MCM	(2) 2/0-500MCM
		400	(2) 4AWG-500MCM	(2) 2/0-500MCM	(2) 2/0-500MCM
200	5V	380	(2) 4AWG-500MCM	(2) 2/0-500MCM	(2) 2/0-500MCM
		400	(2) 4AWG-500MCM	(2) 2/0-500MCM	(2) 2/0-500MCM
200	6V	380	(2) 4AWG-500MCM	(2) 2/0-500MCM	(2) 2/0-500MCM
		400	(2) 4AWG-500MCM	(2) 2/0-500MCM	(2) 2/0-500MCM
225	5V	380	(2) 4AWG-500MCM	(2) 2/0-500MCM	(2) 2/0-500MCM
		400	(2) 4AWG-500MCM	(2) 2/0-500MCM	(2) 2/0-500MCM
225	6V	380	(2) 4AWG-500MCM	(2) 2/0-500MCM	(2) 2/0-500MCM
		400	(2) 4AWG-500MCM	(2) 2/0-500MCM	(2) 2/0-500MCM
250	5V	380	(2) 4AWG-500MCM	(3) 3/0-500MCM	(3) 3/0-500MCM
		400	(2) 4AWG-500MCM	(3) 3/0-500MCM	(3) 3/0-500MCM
250	6V	380	(2) 4AWG-500MCM	(3) 3/0-500MCM	(3) 3/0-500MCM
		400	(2) 4AWG-500MCM	(2) 2/0-500MCM	(2) 2/0-500MCM
275	6V	380	(2) 4AWG-500MCM	(3) 3/0-500MCM	(3) 3/0-500MCM
		400	(2) 4AWG-500MCM	(3) 3/0-500MCM	(3) 3/0-500MCM
275	7V	380	(2) 4AWG-500MCM	(3) 3/0-500MCM	(3) 3/0-500MCM
		400	(2) 4AWG-500MCM	(3) 3/0-500MCM	(3) 3/0-500MCM
300	7V	380	(2) 4AWG-500MCM	(3) 3/0-500MCM	(3) 3/0-500MCM
		400	(2) 4AWG-500MCM	(3) 3/0-500MCM	(3) 3/0-500MCM
300	8V	380	(2) 4AWG-500MCM	(3) 3/0-500MCM	(3) 3/0-500MCM
		400	(2) 4AWG-500MCM	(3) 3/0-500MCM	(3) 3/0-500MCM

Note: Field wire insulation temperature rating must be minimum 90°C unless otherwise specified.

^(a) Condenser length defined by model number digit 25: 4V = A; 5V = B; 6V = C; 7V = D; 8V = E

Table 17. Customer wire selection - units larger than 300 tons, 60Hz

Unit Size	Cond Length ^(a)	Rated Voltage	Terminal Block	Circuit Breaker		Single Point Power	
			Ckt 1 & 2	Ckt 1	Ckt 2	Terminal Block	Circuit Breaker
375	9-10V	380	(2) 4 AWG - 500 kcmil	(3) 3/0 AWG - 500 kcmil	(2) 2/0 AWG - 500 kcmil	(4) 1/0 AWG - 750 kcmil	(4) 3/0 AWG - 500 kcmil
		400	(2) 4 AWG - 500 kcmil	(3) 3/0 AWG - 500 kcmil	(2) 2/0 AWG - 500 kcmil	(4) 1/0 AWG - 750 kcmil	(4) 3/0 AWG - 500 kcmil
		460	(2) 4 AWG - 500 kcmil	(3) 3/0 AWG - 500 kcmil	(2) 2/0 AWG - 500 kcmil	(4) 1/0 AWG - 750 kcmil	(4) 3/0 AWG - 500 kcmil
		575	(2) 4 AWG - 500 kcmil	(3) 3/0 AWG - 500 kcmil	(2) 2/0 AWG - 500 kcmil	(4) 1/0 AWG - 750 kcmil	(4) 3/0 AWG - 500 kcmil
380	11V	380	(2) 4 AWG - 500 kcmil	(3) 3/0 AWG - 500 kcmil	(2) 2/0 AWG - 500 kcmil	(4) 1/0 AWG - 750 kcmil	(4) 3/0 AWG - 500 kcmil
		400	(2) 4 AWG - 500 kcmil	(3) 3/0 AWG - 500 kcmil	(2) 2/0 AWG - 500 kcmil	(4) 1/0 AWG - 750 kcmil	(4) 3/0 AWG - 500 kcmil
		460	(2) 4 AWG - 500 kcmil	(3) 3/0 AWG - 500 kcmil	(2) 2/0 AWG - 500 kcmil	(4) 1/0 AWG - 750 kcmil	(4) 3/0 AWG - 500 kcmil
		575	(2) 4 AWG - 500 kcmil	(3) 3/0 AWG - 500 kcmil	(2) 2/0 AWG - 500 kcmil	(4) 1/0 AWG - 750 kcmil	(4) 3/0 AWG - 500 kcmil
440	9-10V	380	(2) 4 AWG - 500 kcmil	(3) 3/0 AWG - 500 kcmil	(2) 2/0 AWG - 500 kcmil	(4) 1/0 AWG - 750 kcmil	(4) 3/0 AWG - 500 kcmil
		400	(2) 4 AWG - 500 kcmil	(3) 3/0 AWG - 500 kcmil	(2) 2/0 AWG - 500 kcmil	(4) 1/0 AWG - 750 kcmil	(4) 3/0 AWG - 500 kcmil
		460	(2) 4 AWG - 500 kcmil	(3) 3/0 AWG - 500 kcmil	(2) 2/0 AWG - 500 kcmil	(4) 1/0 AWG - 750 kcmil	(4) 3/0 AWG - 500 kcmil
		575	(2) 4 AWG - 500 kcmil	(3) 3/0 AWG - 500 kcmil	(2) 2/0 AWG - 500 kcmil	(4) 1/0 AWG - 750 kcmil	(4) 3/0 AWG - 500 kcmil
450	11V	380	(2) 4 AWG - 500 kcmil	(3) 3/0 AWG - 500 kcmil	(2) 2/0 AWG - 500 kcmil	(4) 1/0 AWG - 750 kcmil	(4) 3/0 AWG - 500 kcmil
		400	(2) 4 AWG - 500 kcmil	(3) 3/0 AWG - 500 kcmil	(2) 2/0 AWG - 500 kcmil	(4) 1/0 AWG - 750 kcmil	(4) 3/0 AWG - 500 kcmil
		460	(2) 4 AWG - 500 kcmil	(3) 3/0 AWG - 500 kcmil	(2) 2/0 AWG - 500 kcmil	(4) 1/0 AWG - 750 kcmil	(4) 3/0 AWG - 500 kcmil
		575	(2) 4 AWG - 500 kcmil	(3) 3/0 AWG - 500 kcmil	(2) 2/0 AWG - 500 kcmil	(4) 1/0 AWG - 750 kcmil	(4) 3/0 AWG - 500 kcmil
500 ^(b)	11V	380	(2) 4 AWG - 500 kcmil	(3) 3/0 AWG - 500 kcmil	(2) 2/0 AWG - 500 kcmil	(4) 1/0 AWG - 750 kcmil	-
		400	(2) 4 AWG - 500 kcmil	(3) 3/0 AWG - 500 kcmil	(2) 2/0 AWG - 500 kcmil	(4) 1/0 AWG - 750 kcmil	-
		460	(2) 4 AWG - 500 kcmil	(3) 3/0 AWG - 500 kcmil	(2) 2/0 AWG - 500 kcmil	(4) 1/0 AWG - 750 kcmil	(4) 3/0 AWG - 500 kcmil
		575	(2) 4 AWG - 500 kcmil	(3) 3/0 AWG - 500 kcmil	(2) 2/0 AWG - 500 kcmil	(4) 1/0 AWG - 750 kcmil	(4) 3/0 AWG - 500 kcmil

Table 17. Customer wire selection - units larger than 300 tons, 60Hz (continued)

Unit Size	Cond Length ^(a)	Rated Voltage	Terminal Block	Circuit Breaker		Single Point Power	
			Ckt 1 & 2	Ckt 1	Ckt 2	Terminal Block	Circuit Breaker
550 ^(b)	11V	380	(2) 4 AWG - 500 kcmil	(3) 3/0 AWG - 500 kcmil	(2) 2/0 AWG - 500 kcmil	(4) 1/0 AWG - 750 kcmil	-
		400	(2) 4 AWG - 500 kcmil	(3) 3/0 AWG - 500 kcmil	(2) 2/0 AWG - 500 kcmil	(4) 1/0 AWG - 750 kcmil	-
		460	(2) 4 AWG - 500 kcmil	(3) 3/0 AWG - 500 kcmil	(2) 2/0 AWG - 500 kcmil	(4) 1/0 AWG - 750 kcmil	(4) 3/0 AWG - 500 kcmil
		575	(2) 4 AWG - 500 kcmil	(3) 3/0 AWG - 500 kcmil	(2) 2/0 AWG - 500 kcmil	(4) 1/0 AWG - 750 kcmil	(4) 3/0 AWG - 500 kcmil

Note: Field wire insulation temperature rating must be minimum 90°C unless otherwise specified.

^(a) Condenser length defined by model number digit 25: 9V = F; 10V = G; 11V = H.

^(b) 500-550 ton units do not have an option for a single point power circuit breaker for 380/60/3 and 400/60/3.

Table 18. Customer wire selection - units larger than 300 tons, 50Hz

Unit Size	Cond Length ^(a)	Rated Voltage	Terminal Block	Circuit Breaker		Single Point Power	
			Ckt 1 & 2	Ckt 1	Ckt 2	Terminal Block	Circuit Breaker ^(b)
375	9-10V	380	(2) 4 AWG - 500 kcmil	(3) 3/0 AWG - 500 kcmil	(2) 2/0 AWG - 500 kcmil	(4) 1/0 AWG - 750 kcmil	(4) 3/0 AWG - 500 kcmil
		400	(2) 4 AWG - 500 kcmil	(3) 3/0 AWG - 500 kcmil	(2) 2/0 AWG - 500 kcmil	(4) 1/0 AWG - 750 kcmil	(4) 3/0 AWG - 500 kcmil
380	11V	380	(2) 4 AWG - 500 kcmil	(3) 3/0 AWG - 500 kcmil	(2) 2/0 AWG - 500 kcmil	(4) 1/0 AWG - 750 kcmil	(4) 3/0 AWG - 500 kcmil
		400	(2) 4 AWG - 500 kcmil	(3) 3/0 AWG - 500 kcmil	(2) 2/0 AWG - 500 kcmil	(4) 1/0 AWG - 750 kcmil	(4) 3/0 AWG - 500 kcmil
440	9-10V	380	(2) 4 AWG - 500 kcmil	(3) 3/0 AWG - 500 kcmil	(2) 2/0 AWG - 500 kcmil	(4) 1/0 AWG - 750 kcmil	(4) 3/0 AWG - 500 kcmil
		400	(2) 4 AWG - 500 kcmil	(3) 3/0 AWG - 500 kcmil	(2) 2/0 AWG - 500 kcmil	(4) 1/0 AWG - 750 kcmil	(4) 3/0 AWG - 500 kcmil
450	11V	380	(2) 4 AWG - 500 kcmil	(3) 3/0 AWG - 500 kcmil	(2) 2/0 AWG - 500 kcmil	(4) 1/0 AWG - 750 kcmil	(4) 3/0 AWG - 500 kcmil
		400	(2) 4 AWG - 500 kcmil	(3) 3/0 AWG - 500 kcmil	(2) 2/0 AWG - 500 kcmil	(4) 1/0 AWG - 750 kcmil	(4) 3/0 AWG - 500 kcmil
500 ^(b)	11V	380	(2) 4 AWG - 500 kcmil	(3) 3/0 AWG - 500 kcmil	(3) 3/0 AWG - 500 kcmil	(4) 1/0 AWG - 750 kcmil	-
		400	(2) 4 AWG - 500 kcmil	(3) 3/0 AWG - 500 kcmil	(3) 3/0 AWG - 500 kcmil	(4) 1/0 AWG - 750 kcmil	-
500 ^(b)	11V	380	(2) 4 AWG - 500 kcmil	(3) 3/0 AWG - 500 kcmil	(3) 3/0 AWG - 500 kcmil	(4) 1/0 AWG - 750 kcmil	-
		400	(2) 4 AWG - 500 kcmil	(3) 3/0 AWG - 500 kcmil	(3) 3/0 AWG - 500 kcmil	(4) 1/0 AWG - 750 kcmil	-

Note: Field wire insulation temperature rating must be minimum 90°C unless otherwise specified.

^(a) Condenser length defined by model number digit 25: 9V = F; 10V = G; 11V = H.

^(b) 500-550 ton units do not have an option for a single point power circuit breaker for 380/50/3 and 400/50/3.

Electrical Connections

Figure 5. Field wiring – 150 to 300 ton units

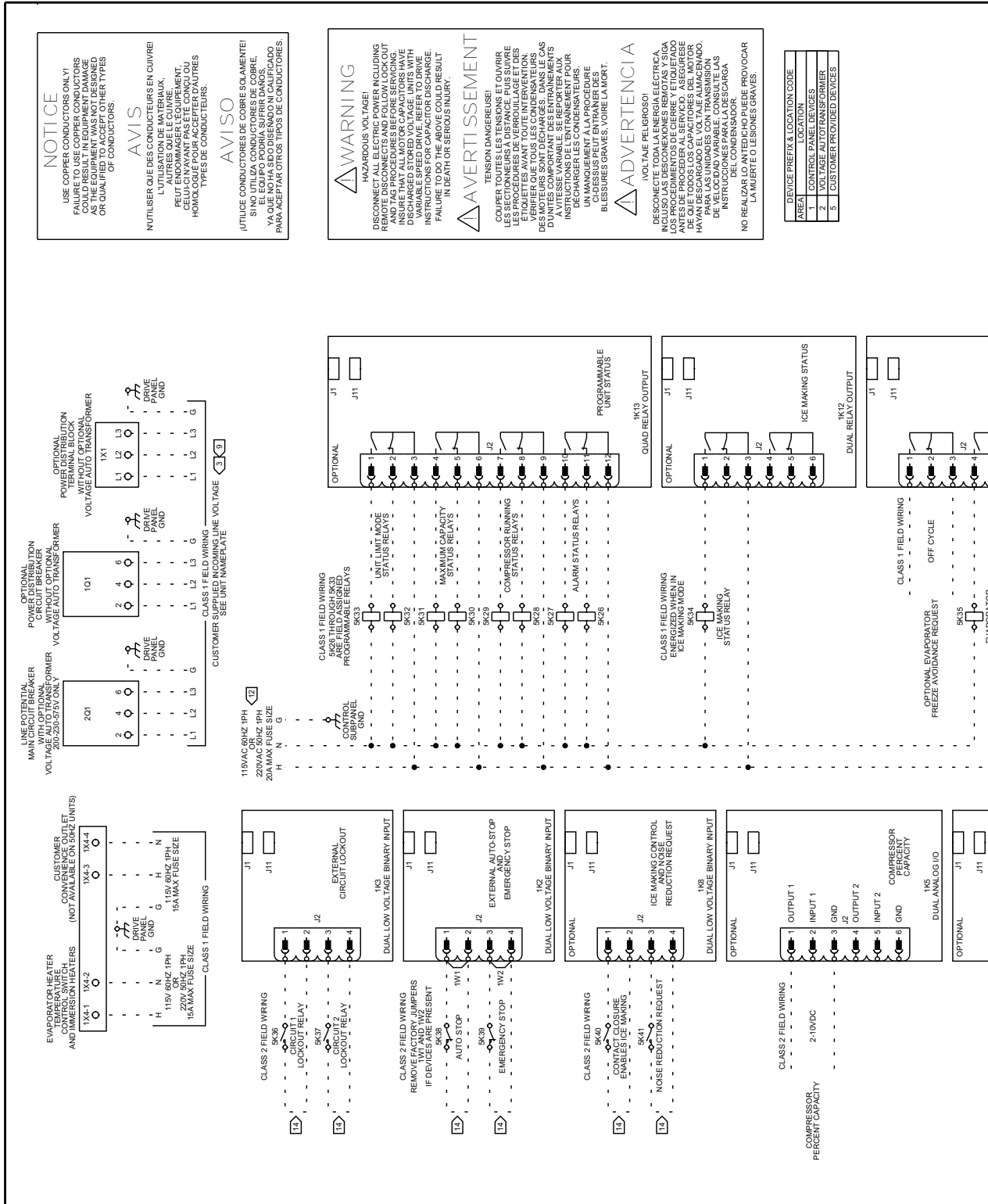

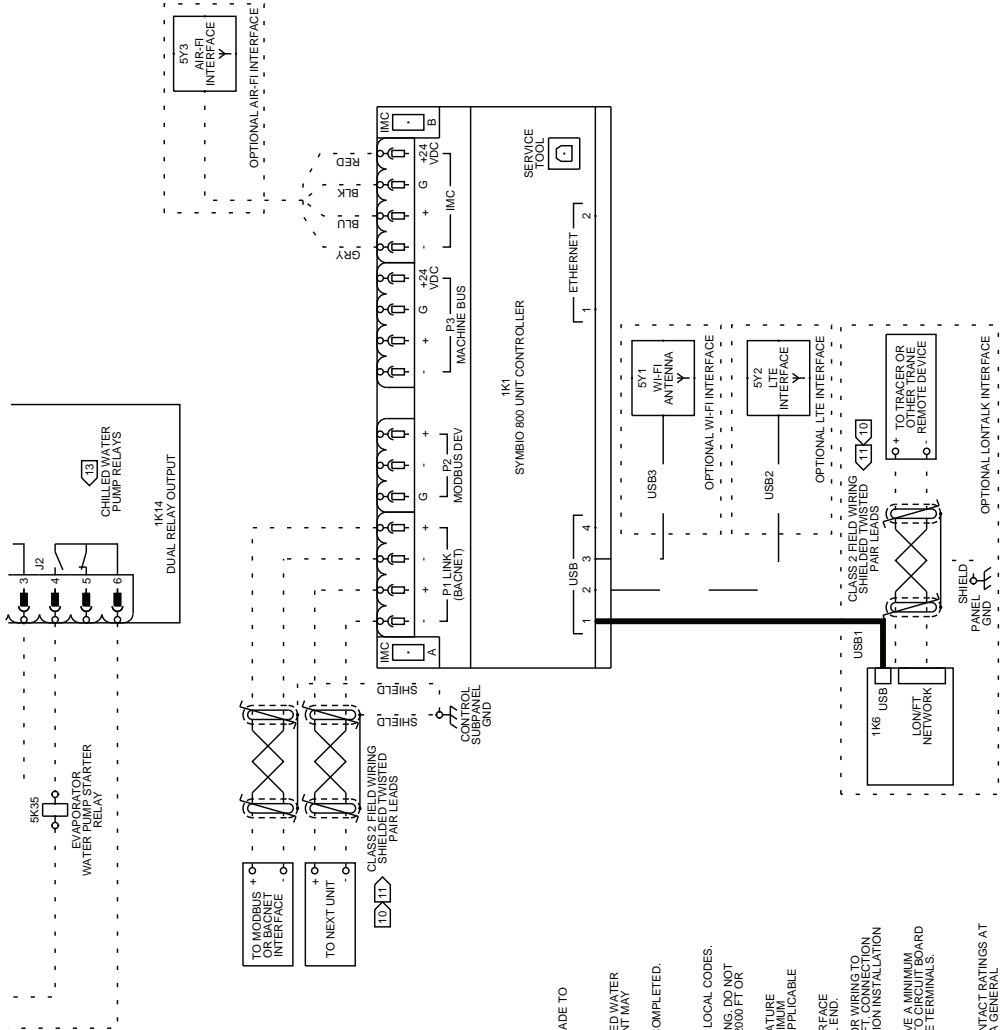

		DIAGRAM UNIT FIELD WIRING	
DRAWN BY: K.M. KULIG TRANE DATE: 03 JUN 2020 MASTER FILE:	ACRB GP4 - 2 COMPRESSORS DRAWING NUMBER 23115513		
REPLACES: SIMILAR TO:	REV SHEET 1 OF 1 B		
USED BY:	CAD: CREO SCHEMATICS		
THIS DRAWING IS PROPRIETARY AND SHALL NOT BE COPIED, REPRODUCED, OR TRANSMITTED TO OUTSIDE PARTIES WITHOUT THE WRITTEN CONSENT OF TRANE			

GENERAL NOTES:

1. WIRE REPRESENTED BY DASHED LINES INDICATE RECOMMENDED FIELD WIRING BY OTHERS.
2. ALL STANDARD AND OPTIONAL COMPONENTS SHOWN.
3. SINGLE SOURCE POWER IS PROVIDED AS STANDARD ON THIS PRODUCT. FIELD CONNECTIONS ARE MADE TO DEVICES 201, 101 OR 1X1.
4. ALL MOTORS ARE PROTECTED FROM PRIMARY SINGLE PHASE FAILURES.
5. CAUTION - TRANE PUMP CONTROL MUST BE USED TO PROVIDE PUMP CONTROL. EVAPORATOR/CHILLED WATER PUMP MUST BE CONTROLLED BY THE CHILLER OUTPUT. FAILURE TO COMPLY WITH THIS REQUIREMENT MAY RESULT IN DAMAGE TO THE UNIT.
6. CAUTION - DO NOT ENERGIZE THE UNIT UNTIL CHECK OUT AND STARTUP PROCEDURES HAVE BEEN COMPLETED.

WIRING REQUIREMENTS:

7. ALL FIELD WIRING MUST BE IN ACCORDANCE WITH THE NATIONAL ELECTRIC CODE (NEC), STATE AND LOCAL CODES.
8. ALL VOLTAGE CONTROL WIRING SHALL BE 18 AWG OR LESS IN CONDUCTIVITY. ALL 120V OR HIGHER WIRING DO NOT EXCEED THE LENGTH MAXIMUM RUN LENGTH FOR A GIVEN SIZE: 14 AWG OF 500 FT; 12 AWG OF 250 FT; 10 AWG OF 100 FT.
9. ALL UNIT POWER WIRING MUST BE 600V COPPER CONDUCTORS ONLY AND HAVE A MINIMUM TEMPERATURE INSULATION RATING OF 90°C. REFER TO UNIT NAMEPLATE FOR MINIMUM CIRCUIT AMPACITY AND MAXIMUM WIRE SIZE. REFER TO WIRE RANGE TABLE FOR WIRE SIZES.
10. SHIELDED TWISTED PAIR LEADS ARE REQUIRED FOR CONNECTIONS TO THE COMMUNICATIONS INTERFACE MODULES 1K1 OR OPTIONAL 1K6. THE SHIELD SHOULD BE GROUNDING AT THE UNIT CONTROL PANEL END.
11. 22 AWG SHIELDED COMMUNICATION WIRE EQUIVALENT TO IEC 11122/20/14 IS RECOMMENDED FOR WIRING TO NEXT UNIT. THE SUM TOTAL OF ALL INTERCONNECTED CABLE SEGMENTS ARE NOT TO EXCEED 500 FT. CONNECTION TOPOLOGY SHOULD BE Daisy Chain. REFER TO BUILDING AUTOMATION SYSTEM (BAS) COMMUNICATION INSTALLATION LITERATURE FOR END OF LINE TERMINATION RESISTOR REQUIREMENTS.
12. ALL CUSTOMER SUPPLIED CONTROL CIRCUIT WIRING MUST BE COPPER CONDUCTORS ONLY AND HAVE A MINIMUM TEMPERATURE INSULATION RATING OF 90°C. REFER TO UNIT NAMEPLATE FOR MINIMUM CIRCUIT AMPACITY AND MAXIMUM WIRE SIZE. REFER TO WIRE RANGE TABLE FOR WIRE SIZES.

CONTACT RATINGS AND REQUIREMENTS:

13. UNIT PROVIDED RELAY CONTACTS FOR THE CONDENSER/ CHILLED WATER PUMP CONTROL. RELAY CONTACT RATINGS AT 120VAC: 7.2A RESISTIVE, 2.8A PILOT DUTY, OR 1/3 HP, 7.2 FLA. CONTACTS ARE RATED FOR 240VAC, 5A GENERAL PURPOSE DUTY.
14. CUSTOMER SUPPLIED CONTACTS FOR ALL LOW VOLTAGE CONNECTIONS MUST BE COMPATIBLE WITH DRY CIRCUIT 24VDC FOR A 12mA RESISTIVE LOAD; SILVER OR GOLD PLATED CONTACTS ARE RECOMMENDED.

Figure 6. Field wiring – units larger than 300 tons

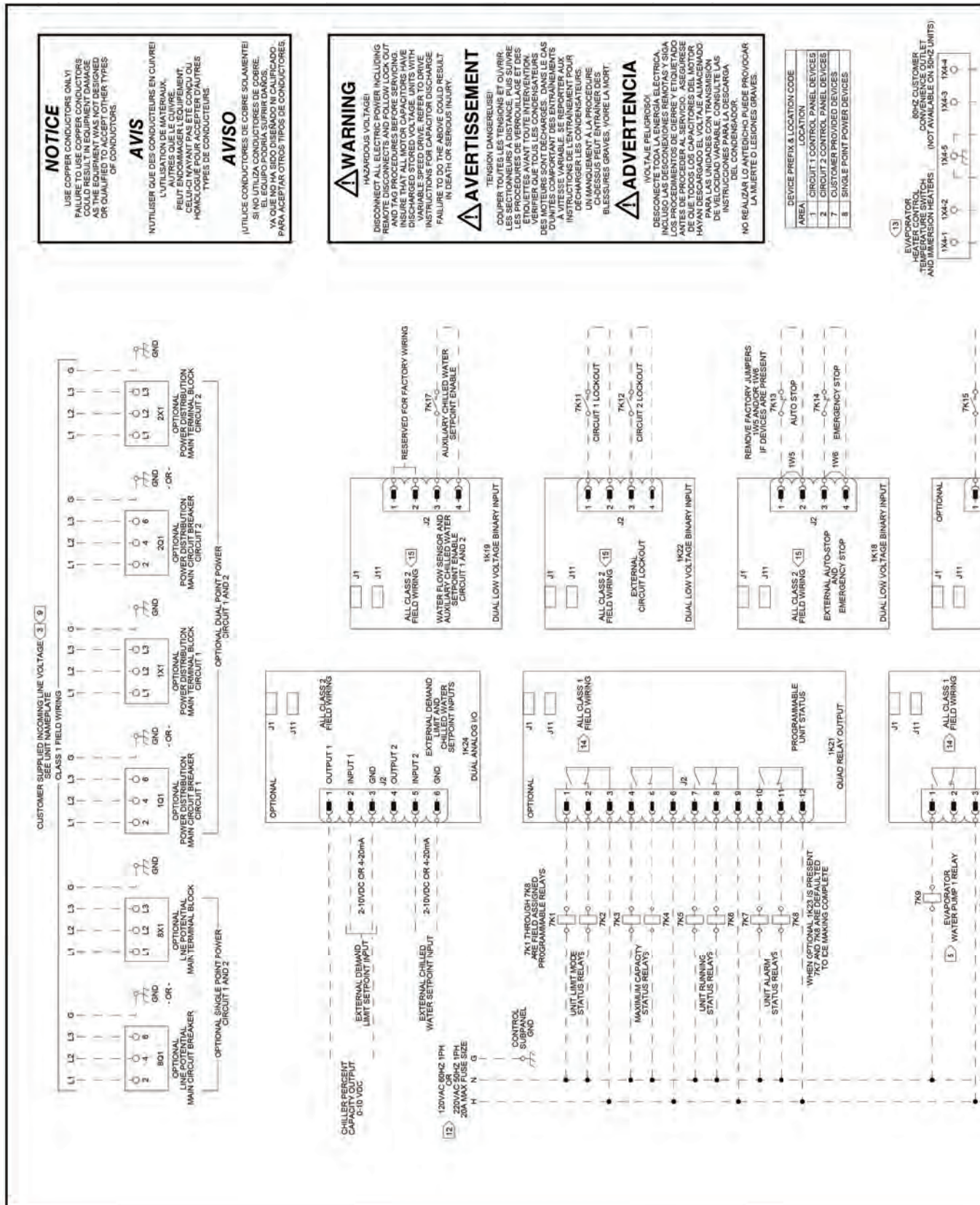

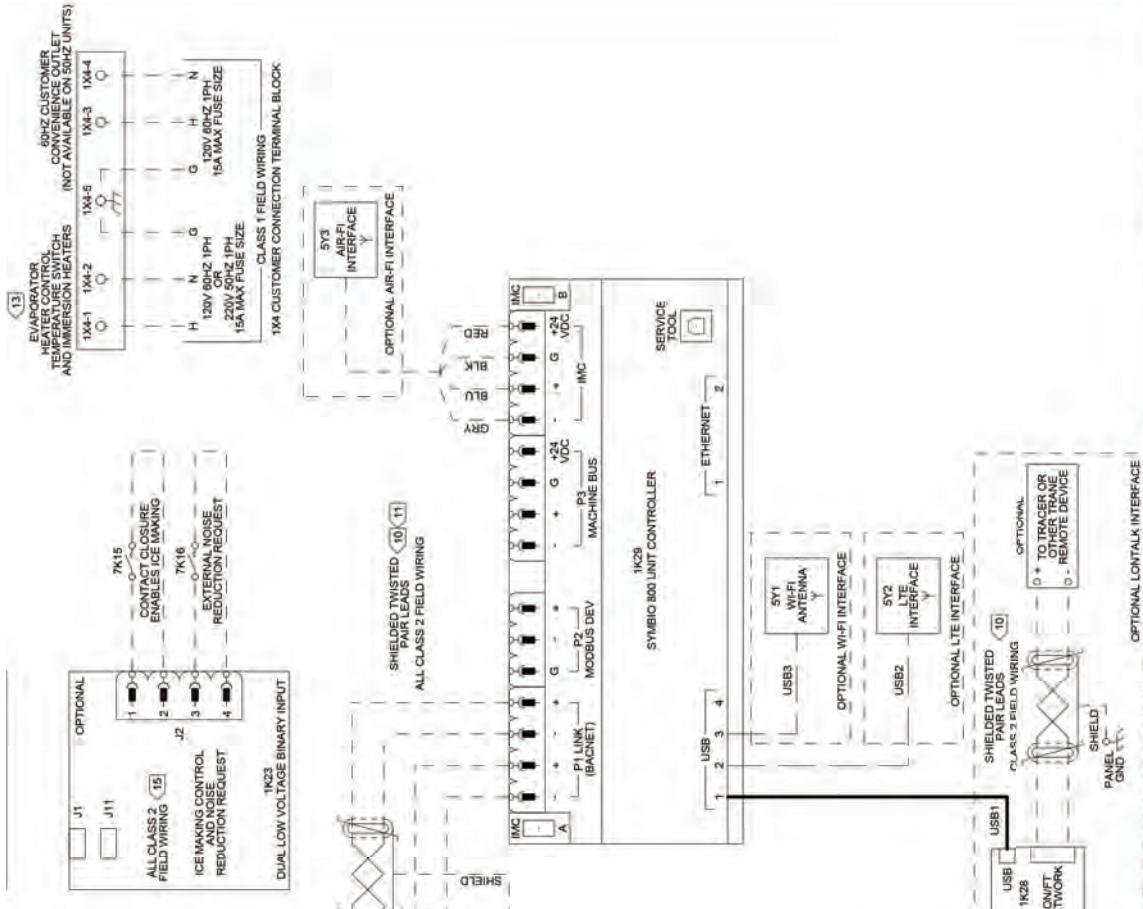

GENERAL NOTES:

1. WIRE REPRESENTED BY DASHED LINES INDICATE RECOMMENDED FIELD WIRINGS BY OTHERS.
2. ALL STANDARD AND OPTIONAL COMPONENTS SHOWN.
3. CUSTOMER SUPPLIED INCOMING LINE VOLTAGE MAY BE MADE TO OPTIONAL SINGLE OR DUAL POINT POWER CONNECTIONS ON THIS PRODUCT AT THE DEVICES SHOWN.
4. ALL MOTORS ARE PROTECTED FROM PRIMARY SINGLE PHASE FAILURES.
5. CAUTION - TRANE PROVIDED 1K20 MUST BE USED TO PROVIDE EVAPORATOR WATER PUMP CONTROL. EVAPORATOR WATER PUMP(S) MUST BE CONTROLLED BY THE CHILLER OUTPUT. FAILURE TO COMPLY WITH THIS REQUIREMENT MAY RESULT IN DAMAGE TO THE UNIT. SEE INSTALLATION, OPERATION AND MAINTENANCE MANUAL FOR ADDITIONAL DETAILS.
6. CAUTION - DO NOT ENERGIZE THE UNIT UNTIL CHECK OUT AND STARTUP PROCEDURES HAVE BEEN COMPLETED.

WIRING REQUIREMENTS:

7. ALL FIELD WIRING MUST BE IN ACCORDANCE WITH THE NATIONAL ELECTRIC CODE (NEC), STATE AND LOCAL CODES.
8. DO NOT RUN LOW VOLTAGE CONTROL WIRING (50V OR LESS) IN CONDUIT WITH 110V OR HIGHER WIRING. DO NOT EXCEED THE FOLLOWING MAXIMUM RUN LENGTH FOR A GIVEN SIZE: 14 AWG OF 5000 FT., 16 AWG OF 2000 FT. OR 18 AWG OF 1000 FT.
9. ALL UNIT POWER WIRING MUST BE 600V COPPER CONDUCTORS ONLY AND HAVE A MINIMUM TEMPERATURE INSULATION RATING OF 90°C. REFER TO UNIT NAMEPLATE FOR MINIMUM CIRCUIT AMPACITY AND MAXIMUM WIRING TEMPERATURE. REFER TO WIRE RANGE TABLE FOR LUG SIZES.
10. SHIELDED, TWISTED PAIR LEADS ARE REQUIRED FOR CONNECTIONS TO THE 1K28 SYMBIO 800 UNIT CONTROLLER AND THE OPTIONAL 1K28 LONTALK INTERFACE. THE SHIELD SHOULD BE GROUND AT THE UNIT CONTROL PANEL END.
11. 22 AWG SHIELDED COMMUNICATION WIRE EQUIVALENT TO HELIX LF229014316 IS RECOMMENDED FOR WIRING TO NEXT UNIT. THE SUM TOTAL OF ALL INTERCONNECTED CABLE SEGMENTS ARE NOT TO EXCEED 4500 FT. CONNECTION TOPOLOGY SHOULD BE DAISSY CHAIN. REFER TO BUILDING AUTOMATION SYSTEM (BAS) COMMUNICATION INSTALLATION LITERATURE FOR END OF LINE TERMINATION RESISTOR REQUIREMENTS.
12. ALL CUSTOMER SUPPLIED CONTROL CIRCUIT WIRING MUST BE COPPER CONDUCTORS ONLY AND HAVE A MINIMUM INSULATION RATING OF 90°C. REFER TO UNIT NAMEPLATE FOR MINIMUM CIRCUIT AMPACITY AND MAXIMUM WIRING TEMPERATURE. REFER TO WIRE RANGE TABLE FOR LUG SIZES.
13. EVAPORATOR HEATER CONTROL, TEMPERATURE SWITCH AND IMMERSION HEATERS ARE MANDATORY FOR NON-GLYCOL MEDIUMS. SEE IOM FREEZE AVOIDANCE FOR DETAILS.

CONTACT RATINGS AND REQUIREMENTS:

14. UNIT PROVIDED DRY CONTACTS FOR THE EVAPORATOR CHILLED WATER PUMP CONTROLS AND PROGRAMMABLE UNIT STATUS RELAYS. RELAY CONTACT RATINGS AT 20VAC: 7.2A RESISTIVE, 2.88A PILOT DUTY, OR 1.0 HP, 7.2 FLA. CONTACTS ARE RATED FOR 30VAC, 5A GENERAL PURPOSE DUTY.
15. CUSTOMER SUPPLIED CONTACTS FOR ALL LOW VOLTAGE CONNECTIONS MUST BE COMPATIBLE WITH DRY CIRCUIT 34VDC FOR A 12mA RESISTIVE LOAD. GOLD PLATED CONTACTS ARE RECOMMENDED.

DIAGRAM
UNIT FIELD WIRING

TRANE®

THIS DRAWING IS PROPRIETARY AND SHALL NOT BE COPIED OR ITS CONTENTS DISCLOSED WITHOUT THE WRITTEN CONSENT OF TRANE.

CAD: CRO SCHEMATICS

DRAWING NUMBER: ACRB 375-560 TON UNITS

23115360

SHEET 1 OF 1

REV C

DRAWN BY:	K.M. KULIG
© TRANE DATE:	18 MAR 2020
MASTER FILE:	
REVISION DATE:	13 SEP 2021
REPLACES:	
SIMILAR TO:	
USED BY:	



Dimensions and Weights

Weights

Table 19. Weights – 150 to 275 ton units

Unit Size (tons)	Condenser Length ^(a)	Standard Length ^(b)				Extended Length ^(b)			
		Shipping		Operating		Shipping		Operating	
		lb	kg	lb	kg	lb	kg	lb	kg
Units without Seismic or Direct Free-Cooling Options ^(b)									
150	4V	12000	5443	12200	5534	14200	6441	14400	6532
165	4V	12100	5489	12200	5534	14200	6441	14400	6532
	5V	13100	5942	13200	5987	15200	6895	15400	6985
180	4V	12200	5534	12400	5625	14600	6623	14800	6713
	5V	13400	6078	13500	6124	15500	7031	15700	7121
200	5V	13400	6078	13600	6169	15600	7076	15700	7121
	6V	14600	6623	14800	6713	16600	7530	16800	7620
225	5V	14800	6713	15000	6804	17000	7711	17200	7802
	6V	15900	7212	16100	7303	18100	8210	18300	8301
250	5V	14900	6759	15100	6849	17000	7711	17200	7802
	6V	16300	7394	16500	7484	18400	8346	18700	8482
275	6V	16300	7394	16600	7530	18500	8392	18800	8528
	7V	17400	7893	17700	8029	19600	8891	19800	8981
Units with Direct Free-Cooling Option (no Seismic) ^(b)									
150	4V	n/a	n/a	n/a	n/a	n/a	n/a	n/a	n/a
165	4V	n/a	n/a	n/a	n/a	n/a	n/a	n/a	n/a
	5V	16000	7258	17200	7802	18800	8528	20100	9117
180	4V	n/a	n/a	n/a	n/a	n/a	n/a	n/a	n/a
	5V	16800	7620	18000	8165	19700	8936	19900	9027
200	5V	n/a	n/a	n/a	n/a	n/a	n/a	n/a	n/a
	6V	18600	8437	20000	9072	20900	9480	22400	10161
225	5V	n/a	n/a	n/a	n/a	n/a	n/a	n/a	n/a
	6V	19900	9027	21300	9662	22300	10115	23800	10796
250	5V	n/a	n/a	n/a	n/a	n/a	n/a	n/a	n/a
	6V	20300	9208	21700	9843	22700	10297	24200	10977
275	6V	n/a	n/a	n/a	n/a	n/a	n/a	n/a	n/a
	7V	23900	10900	24200	10950	26400	12000	26600	12050
Units with Seismic Option (no Direct Free-Cooling) ^(b)									
150	4V	12600	5727	12800	5818	14800	6727	15000	6818
165	4V	12700	5773	12800	5818	14800	6727	15000	6818
	5V	13750	6250	13850	6295	15850	7205	16050	7295
180	4V	12800	5818	13000	5909	15200	6909	15400	7000
	5V	14050	6386	14150	6432	16150	7341	16350	7432
200	5V	14050	6386	14250	6477	16250	7386	16350	7432
	6V	15400	7000	15600	7091	17400	7909	17600	8000
225	5V	15450	7023	15650	7114	17650	8023	17850	8114
	6V	16700	7591	16900	7682	18900	8591	19100	8682

Table 19. Weights – 150 to 275 ton units (continued)

Unit Size (tons)	Condenser Length ^(a)	Standard Length ^(b)				Extended Length ^(b)			
		Shipping		Operating		Shipping		Operating	
		lb	kg	lb	kg	lb	kg	lb	kg
250	5V	15550	7068	15750	7159	17650	8023	17850	8114
	6V	17100	7773	17300	7864	19200	8727	19500	8864
275	6V	17100	7773	17400	7909	19300	8773	19600	8909
	7V	18250	8295	18550	8432	20450	9295	20650	9386
Units with Seismic and Direct Free-Cooling Options ^(b)									
150	4V	n/a	n/a	n/a	n/a	n/a	n/a	n/a	n/a
165	4V	n/a	n/a	n/a	n/a	n/a	n/a	n/a	n/a
	5V	16650	7568	17850	8114	19450	8841	20750	9432
180	4V	n/a	n/a	n/a	n/a	n/a	n/a	n/a	n/a
	5V	17450	7932	18650	8477	20350	9250	20550	9341
200	5V	n/a	n/a	n/a	n/a	n/a	n/a	n/a	n/a
	6V	19400	8818	20800	9455	21700	9864	23200	10545
225	5V	n/a	n/a	n/a	n/a	n/a	n/a	n/a	n/a
	6V	20700	9409	22100	10045	23100	10500	24600	11182
250	5V	n/a	n/a	n/a	n/a	n/a	n/a	n/a	n/a
	6V	21100	9591	22500	10227	23500	10682	25000	11364
275	6V	n/a	n/a	n/a	n/a	n/a	n/a	n/a	n/a
	7V	24750	11250	25050	11386	27250	12386	27450	12477

Notes:

- Weights include factory charge of refrigerant and oil, ultimate sound option, and architectural louvered panels.
- All weights are plus/minus 10%.

^(a) Condenser length defined by model number digit 25: 4V = A; 5V = B; 6V = C; 7V = D.

^(b) Direct Free-Cooling defined by model number digit 42 = T. Seismic option is defined by model number digit 36 = B, D, or E.

Table 20. Weights – 300 ton units

Unit Size (tons)	Condenser Length ^(a)	With Pump Package ^(b)	Free-Cooling Type ^(c)	Standard Length				Extended Length ^(d)			
				Shipping		Operating		Shipping		Operating	
				lb	kg	lb	kg	lb	kg	lb	kg
Without Seismic Option ^(e)											
300	7V	n/a	n/a	17500	7938	17700	8029	19600	8891	19900	9027
300	8V	n/a	n/a	18500	8392	18800	8528	20700	9389	20900	9480
		n/a	TDFC	23400	10590	25300	11460	25800	11670	27700	12560
		PUMP	TDFC	27600	12470	31100	14080	26900	12160	33500	15180
		n/a	DFCP	25600	11600	27500	12470	27800	12540	30000	13570
		PUMP	DFCP	29800	13490	33300	15090	31900	14420	35700	16190
		n/a	TIFC	26300	11900	29500	13350	28700	12980	31900	14460
		n/a	IFCP	28200	12770	31700	14370	30700	13850	34200	15470
PUMP	IFCP	32400	14660	37500	16990	34800	15730	39900	18090		
With Seismic Option ^(e)											
300	7V	n/a	n/a	18350	8324	18550	8414	20450	9276	20750	9412
300	8V	n/a	n/a	19500	8845	19800	8981	21700	9843	21900	9934
		n/a	TDFC	24400	11068	26300	11930	26800	12156	28700	13018

Notes:

- Weights include factory charge of refrigerant and oil, ultimate sound option, and architectural louvered panels.
- All weights are plus/minus 10%.

^(a) Condenser length defined by model number digit 25: 7V = D; 8V = E.



Dimensions and Weights

Table 20. Weights – 300 ton units (continued)

- (b) Pump Package defined by model number digit 40 = 5, 6, 7.
 (c) Direct Free Cooling defined by model number digit 42: T = TDFC; H = DFCP; F = TIFC; E = IFCP.
 (d) Extended Length is required for voltages 200V, 230V, or 575V (model number digit 9 = A, B, or F) and harmonic filtration model number digit 44 = L.
 (e) Seismic defined by model number digit 36 = B, D, or E.

Table 21. Weights – units larger than 300 tons

Unit Size (tons)	Standard Unit with SPP ^(a)				Std Unit with SPP and Options Box ^(b)				Additional Option Weight ^(c)	
	Shipping		Operating		Shipping		Operating		Louver	
	lb	kg	lb	kg	lb	kg	lb	kg	lb	kg
Units without Direct Free-Cooling ^(d)										
375	17300	7847	17676	8018	19554	8869	19931	9040	757 / 839	343 / 381
380	18797	8526	19174	8697	20484	9291	20860	9462	921	418
440	17300	7847	17676	8018	19554	8869	19931	9040	757 / 839	343 / 381
450	18797	8526	19174	8697	20484	9291	20860	9462	921	418
500	20678	9379	21169	9602	22365	10144	22856	10367	921	418
550	20678	9379	21169	9602	22365	10144	22856	10367	921	418
Units with Direct Free-Cooling ^(d)										
375	n/a	n/a	n/a	n/a	n/a	n/a	n/a	n/a	n/a	n/a
380	26000	11890	26500	12010	27700	12660	28200	12780	1136	515
440	n/a	n/a	n/a	n/a	n/a	n/a	n/a	n/a	n/a	n/a
450	26000	11890	26500	12010	27700	12660	28200	12780	1136	515
500	27900	12770	28500	12890	29600	13530	30100	13650	1136	515
550	27900	12770	28500	12890	29600	13530	30100	13650	1136	515

Notes:

1. Weights include factory charge of refrigerant and oil, and Superior sound option.
 2. All weights are plus/minus 10%.
- (a) Single Point Power (SPP) is indicated by model number digit 29 = 1
 (b) Options box is used for units with either 575V (model number digit 9 = F) or Low Harmonics Option (model number digit 44 = L).
 (c) Option weight is in addition to standard unit with SPP weight. (Std Unit/Unit with Options Box)
 (d) Direct Free-Cooling defined by model number digit 42 = T.

Service Clearance

Figure 7. Unit service clearance requirements — 150 to 300 ton units

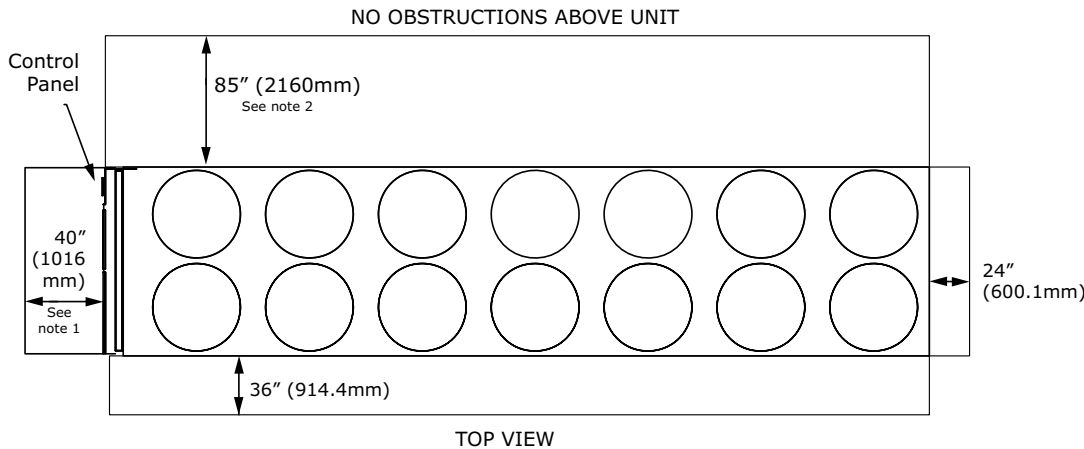
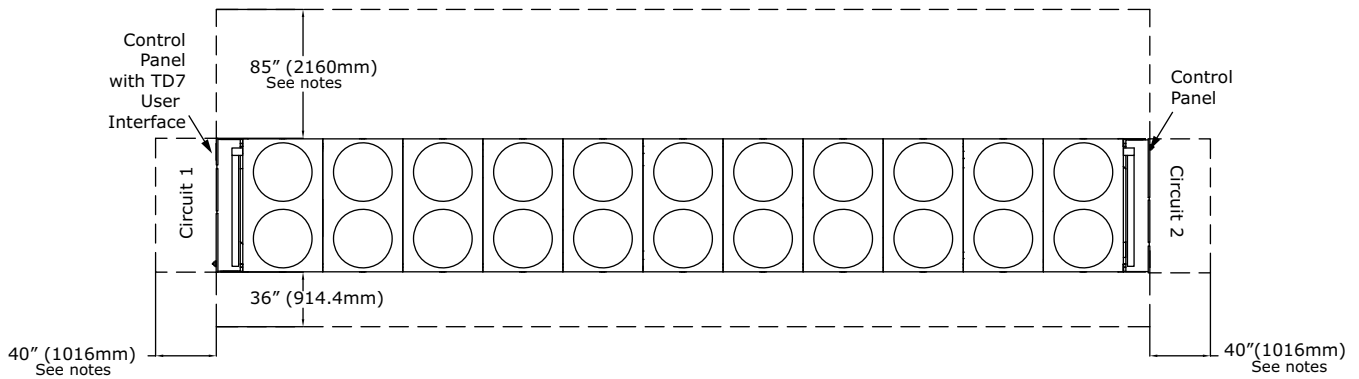

Figure 8. Unit service clearance requirements — units larger than 300 tons



Notes:

1. A full 40" clearance is required in front of the control panel(s). Must be measured from front of panel, not end of unit base. Installer must also follow NEC and local/state codes for electrical clearance requirements.
2. Area above unit is required for operation, maintenance, access panel and air flow. No obstructions above unit.
3. Clearance of 85" on the side of the unit is required for coil replacement. Preferred side for coil replacement is shown (left side of the unit, as facing control panel), however either side is acceptable.
4. For obstructions or multiple units, refer to close spacing bulletin.



Dimensions and Weights

Unit Dimensions

Unit Sizes 150 to 300 Tons

Figure 9. Dimensions — 150 to 300 ton units, standard length, 2-pass

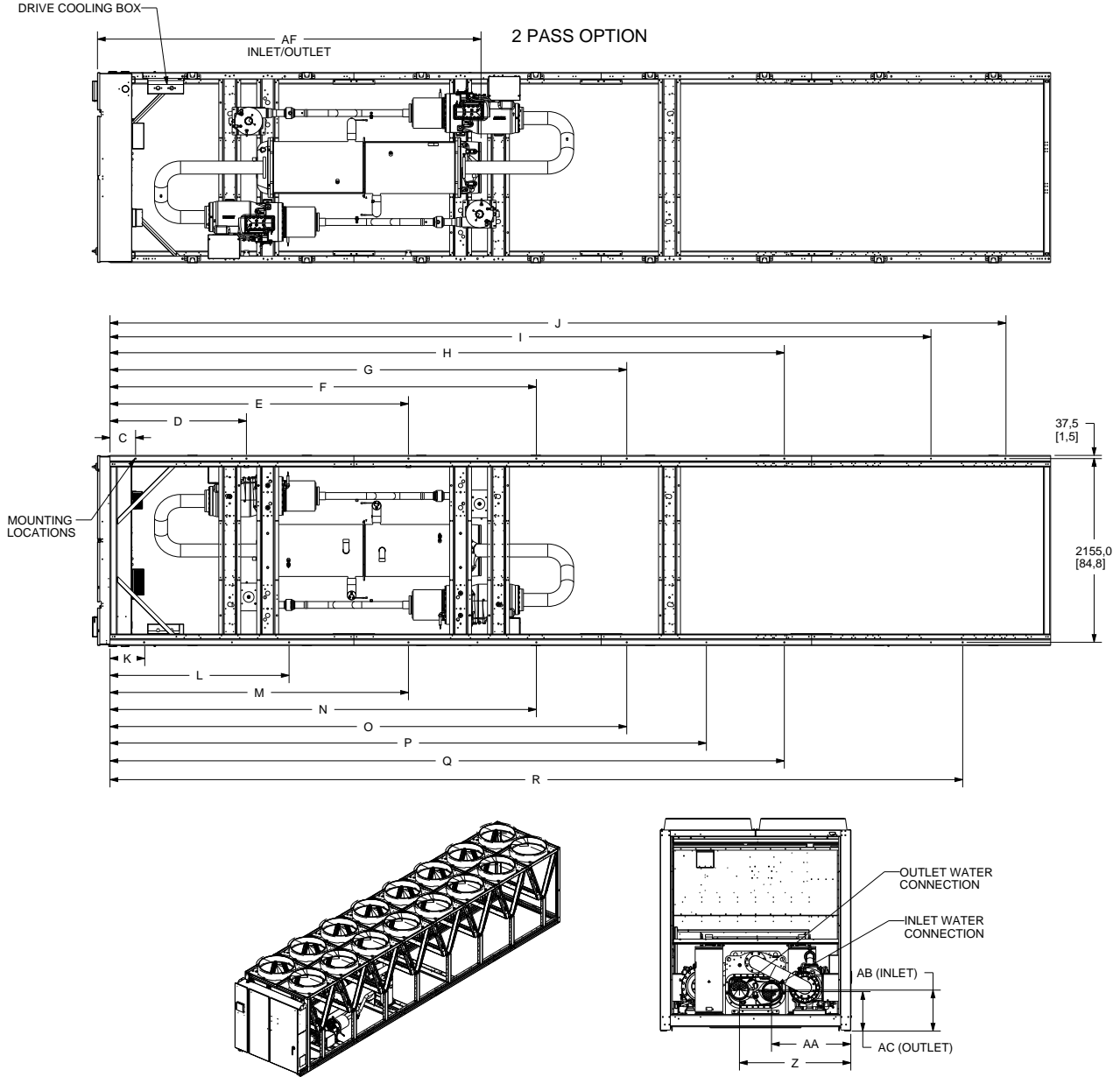
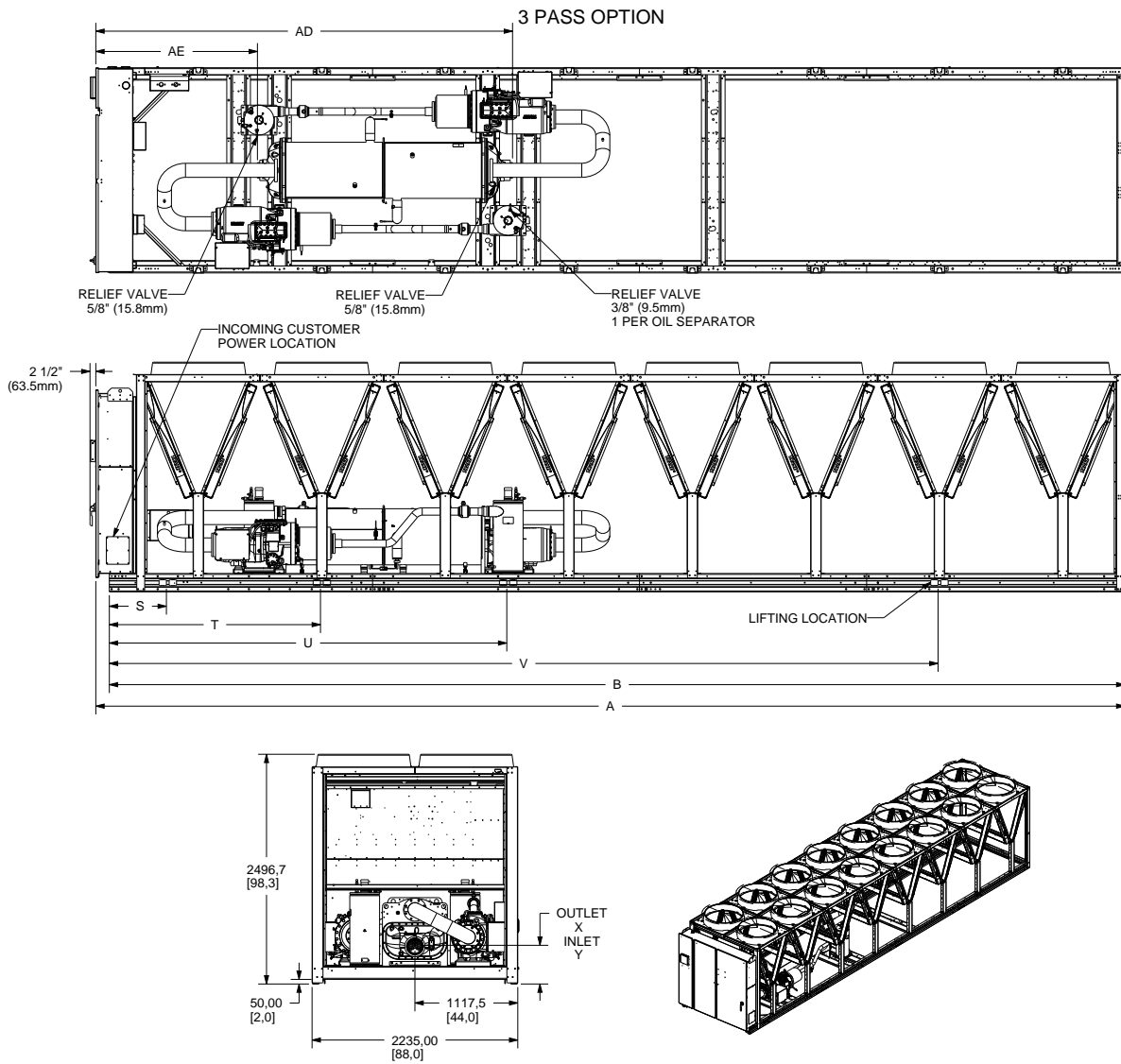

Figure 10. Dimensions – 150 to 300 ton units, standard length, 3-pass





Dimensions and Weights

Table 22. Dimensions – 150 to 275 ton units, standard length

Unit Size (tons)	150, 165, 180		165, 180, 200, 225, 250		200, 225, 250, 275		275	
Condenser Length ^(a)	4V		5V		6V		7V	
Dimension	in	mm	in	mm	in	mm	in	mm
A	228.9	5813	281.7	7155	334.5	8497	387.4	9839
B	223.0	5664	275.8	7006	328.6	8348	381.5	9690
C	11.8	300	11.8	300	11.8	300	11.8	300
D	63.0	1600	63.0	1600	63.0	1600	63.0	1600
E	141.7	3600	137.8	3500	137.8	3500	124.4	3160
F	204.7	5200	255.9	6500	238.6	6060	196.9	5000
G	n/a	n/a	n/a	n/a	315.0	8000	334.6	8500
K	15.7	400	15.7	400	15.7	400	15.7	400
L	82.7	2100	82.7	2100	82.7	2100	82.7	2100
M	141.7	3600	137.8	3500	137.8	3500	124.4	3160
N	204.7	5200	255.9	6500	238.6	6060	196.9	5000
O	n/a	n/a	n/a	n/a	315.0	8000	334.6	8500
S	25.0	635	25.0	635	25.0	635	25.0	635
T	128.1	3255	145.6	3699	65.9	1674	65.9	1674
U	n/a	n/a	n/a	n/a	120.5	3061	158.5	4026

^(a) Condenser length defined by model number digit 25: 4V = A; 5V = B; 6V = C; 7V = D.

Table 23. Dimensions — 300 ton units, standard length, without seismic option

Cond Length ^(a)	7V						8V									
	n/a		None		TDFC		TIFC		TDFC		DFCP, IFCP		DFCP		IFCP	
	in	mm	in	mm	in	mm	in	mm	in	mm	in	mm	in	mm	in	mm
Free-Cooling ^(b)	n/a		None		TDFC		TIFC		TDFC		DFCP, IFCP		DFCP		IFCP	
Pump Option ^(c)	n/a		None		None		None		Pump		None		Pump		Pump	
Dim	in	mm	in	mm	in	mm	in	mm	in	mm	in	mm	in	mm	in	mm
A	387.4	9839	440.2	11181	440.2	11181	440.2	11181	440.2	11181	545.8	13863	545.8	13863	545.8	13863
B	381.5	9690	434.3	11032	434.3	11032	434.3	11032	434.3	11032	540.0	13716	540.0	13716	540.0	13716
C	11.8	300	11.8	300	11.8	300	11.8	300	11.8	300	11.8	300	11.8	300	11.8	300
D	63.0	1600	63.0	1600	63.0	1600	63.0	1600	63.0	1600	63.0	1600	63.0	1600	63.0	1600
E	124.4	3160	137.8	3500	137.8	3500	137.8	3500	137.8	3500	137.8	3500	137.8	3500	137.8	3500
F	196.9	5000	238.6	6060	196.9	5000	196.9	5000	196.9	5000	196.9	5000	196.9	5000	196.9	5000
G	n/a	n/a	n/a	n/a	311.3	7908	413.4	10500	311.3	7908	413.4	10500	311.3	7908	413.4	10500
H	334.6	8500	413.4	10500	413.4	10500	311.3	7908	238.6	6060	311.3	7908	238.6	6060	311.3	7908
I	n/a	n/a	n/a	n/a	n/a	n/a	n/a	n/a	413.4	10500	518.0	13158	413.4	10500	449.1	11408
J	n/a	n/a	n/a	n/a	n/a	n/a	n/a	n/a	n/a	n/a	n/a	n/a	n/a	n/a	518.0	13158
K	15.7	400	15.7	400	15.7	400	15.7	400	15.7	400	15.7	400	15.7	400	15.7	400
L	82.7	2100	82.7	2100	82.7	2100	82.7	2100	82.7	2100	82.7	2100	82.7	2100	82.7	2100
M	124.4	3160	137.8	3500	137.8	3500	137.8	3500	137.8	3500	137.8	3500	137.8	3500	137.8	3500
N	196.9	5000	238.6	6060	196.9	5000	196.9	5000	196.9	5000	196.9	5000	196.9	5000	196.9	5000
O	n/a	n/a	n/a	n/a	311.3	7908	311.3	7908	238.6	6060	311.3	7908	238.6	6060	311.3	7908
P	334.6	8500	393.7	10000	393.7	10000	393.7	10000	311.3	7908	393.7	10000	311.3	7908	393.7	10000
Q	n/a	n/a	n/a	n/a	n/a	n/a	n/a	n/a	393.7	10000	518.0	13158	393.7	10000	449.1	11408
R	n/a	n/a	n/a	n/a	n/a	n/a	n/a	n/a	n/a	n/a	n/a	n/a	n/a	n/a	518.0	13158
S	25.0	635	25.0	635	25.0	635	25.0	635	25.0	635	25.0	635	25.0	635	25.0	635
T	65.9	1674	65.9	1674	65.9	1674	65.9	1674	65.9	1674	65.9	1674	65.9	1674	65.9	1674
U	158.5	4026	79.7	2024	79.7	2024	79.7	2024	79.7	2024	79.7	2024	79.7	2024	79.7	2024
V	n/a	n/a	184.5	4686	184.5	4686	184.5	4686	184.5	4686	184.5	4686	184.5	4686	184.5	4686
W	n/a	n/a	n/a	n/a	n/a	n/a	n/a	n/a	n/a	n/a	487.0	12369	487.0	12369	487.0	12369

(a) Condenser length defined by model number digit 25: 7V = D; 8V = E.

(b) Free Cooling defined by model number digit 42: T = TDFC; H = DFCP; F = TIFC; E = IFCP.

(c) Pump Package defined by model number digit 40 = 5, 6, 7.



Dimensions and Weights

Table 24. Dimensions – 300 ton units, standard length, with seismic option

Cond Length ^(a)	8V			
	None		TDFC	
Free- Cooling ^(b)	None		None	
Pump Option ^(c)	None		None	
Dim	in	mm	in	mm
A	440.2	11181	440.2	11181
B	434.3	11032	434.3	11032
C	11.8	300	11.8	300
D	63.0	1600	63.0	1600
E	137.8	3500	137.8	3500
F	238.6	6060	238.6	6060
G	311.3	7908	311.3	7908
H	413.4	10500	413.4	10500
I	n/a	n/a	n/a	n/a
J	n/a	n/a	n/a	n/a
K	15.7	400	15.7	400
L	82.7	2100	82.7	2100
M	137.8	3500	137.8	3500
N	238.6	6060	238.6	6060
O	311.3	7908	311.3	7908
P	393.7	10000	393.7	10000
Q	n/a	n/a	n/a	n/a
R	n/a	n/a	n/a	n/a
S	25.0	635	25.0	635
T	65.9	1674	65.9	1674
U	79.7	2024	79.7	2024
V	184.5	4686	184.5	4686
W	n/a	n/a	n/a	n/a

Note: Seismic is defined by model number digit 36 = B or E.

(a) Condenser length defined by model number digit 25: 7V = D; 8V = E.

(b) Free Cooling defined by model number digit 42: T = TDFC; H = DFCP; F = TIFC; E = IFCP.

(c) Pump Package defined by model number digit 40 = 5, 6, 7.

Table 25. Water connection dimensions – 150 to 300 ton units, standard length, without free-cooling or pump package

Unit Size (tons)	150, 165		180, 200		225, 250		275, 300	
	in	mm	in	mm	in	mm	in	mm
X	20.4	519.5	19.6	497.5	21.8	553.6	20.6	522.5
Y	17.7	449.5	15.4	390.5	17.6	446.6	16.1	407.7
Z	49.3	1252.5	49.9	1268.0	49.9	1268.0	51.3	1303.3
AA	38.5	977.5	37.9	962.0	37.9	962.0	36.5	927.3
AB	19.3	489.5	17.6	447.5	19.8	503.6	18.2	462.5
AC	19.7	499.5	18.2	462.5	20.4	518.6	18.9	480.5
AD	176.5	4483.1	178.2	4526.3	178.1	4523.7	178.4	4531.4
AE	70.3	1785.6	69.2	1757.7	69.2	1757.7	69.3	1760.2
AF	175.3	4452.6	176.2	4475.5	176.2	4475.5	177.1	4498.3

Dimensions and Weights

Figure 11. Dimensions – 150 to 300 ton units, extended length

VOLTAGE AUTO TRANSFORMER OPTION USED WITH 200, 230 & 575V

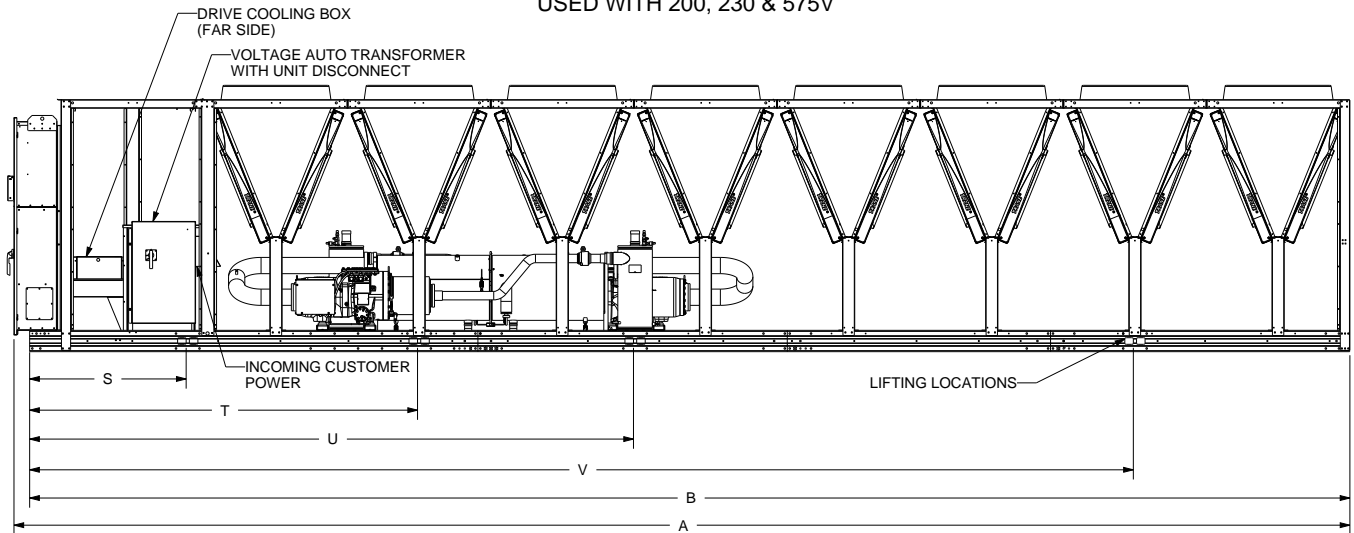

HARMONIC FILTRATION OPTION

NOTE: Side dimension locations are the same as shown for Voltage Auto Transformer option above.

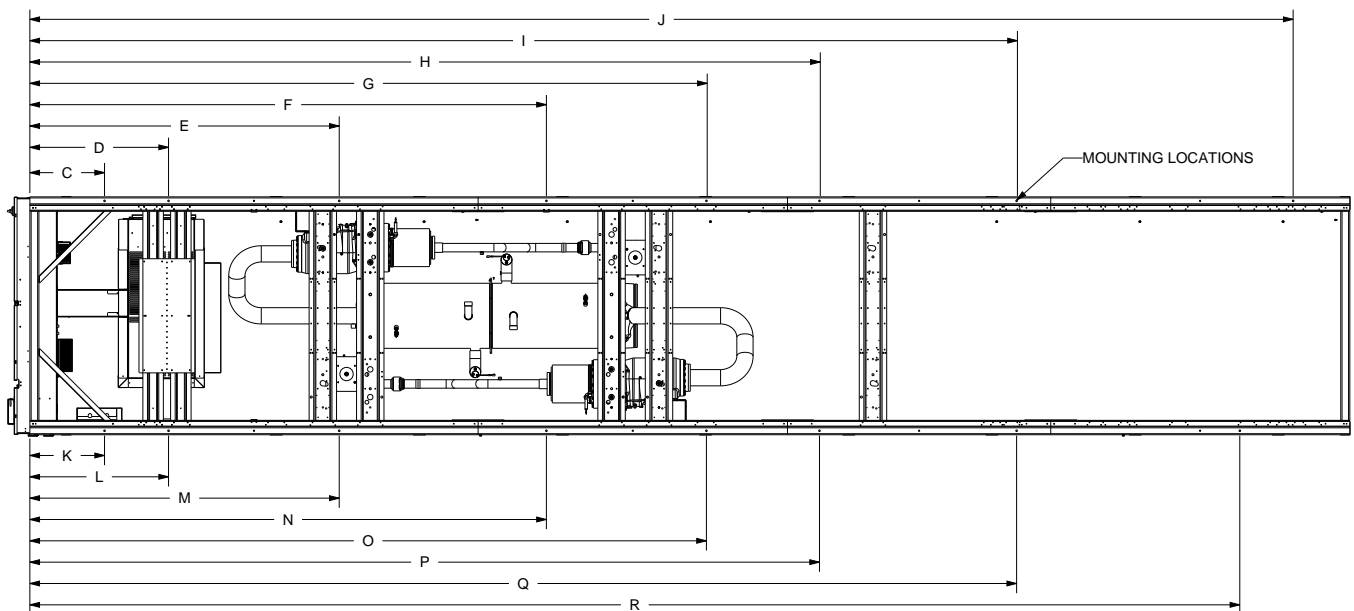
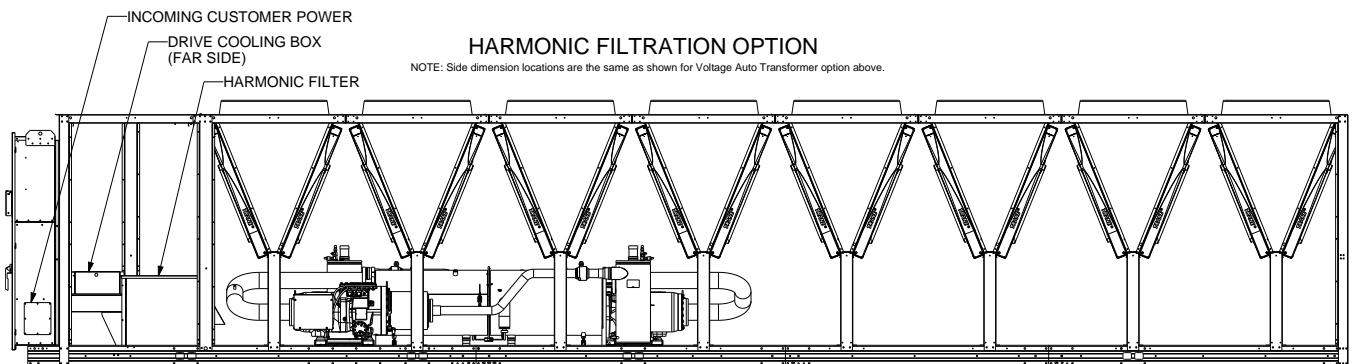

Table 26. Dimensions – 150 to 275 ton units, extended length

Unit Size (tons)	150, 165, 180		165, 180, 200, 225, 250		200, 225, 250, 275		275	
Condenser Length ^(a)	4V		5V		6V		7V	
Dimension	in	mm	in	mm	in	mm	in	mm
A	281.7	7155	334.5	8497	387.4	9839	440.2	11181
B	275.8	7006	328.6	8348	381.5	9690	434.3	11032
C	27.6	700	27.6	700	51.2	1300	51.2	1300
D	114.2	2900	114.2	2900	114.2	2900	114.2	2900
E	194.6	4942	190.6	4842	190.6	4842	177.2	4502
F	257.6	6542	308.7	7842	249.7	6342	249.7	6342
G	n/a	n/a	n/a	n/a	367.8	9342	387.5	9842
K	27.6	700	27.6	700	51.2	1300	51.2	1300
L	114.2	2900	114.2	2900	114.2	2900	114.2	2900
M	194.6	4942	190.6	4842	190.6	4842	177.2	4502
N	257.6	6542	308.7	7842	249.7	6342	249.7	6342
O	n/a	n/a	n/a	n/a	367.8	9342	387.5	9842
S	55.1	1400	55.1	1400	58.3	1482	58.3	1482
T	150.9	3832	168.4	4276	85.4	2169	85.4	2169
U	n/a	n/a	n/a	n/a	120.5	3061	158.5	4026

^(a) Condenser length defined by model number digit 25: 4V = A; 5V = B; 6V = C; 7V = D.

Table 27. Unit Dimensions — 300 ton units, extended length, without seismic option

Cond Length ^(a)	7V						8V									
	n/a		None		TDFC		TIFC		TDFC		DFCP		IFCP		DFCP, IFCP	
	in	mm	in	mm	in	mm	in	mm	in	mm	in	mm	in	mm	in	mm
Free-Cooling ^(b)	n/a		None		TDFC		TIFC		TDFC		DFCP		IFCP		DFCP, IFCP	
Pump Option ^(c)	n/a		None		None		None		Pump		None		None		Pump	
Dim	in	mm	in	mm	in	mm	in	mm	in	mm	in	mm	in	mm	in	mm
A	440.2	11181	493.0	12523	493.0	12523	493.0	12523	493.0	12523	598.6	15204	598.6	15204	598.6	15204
B	434.3	11032	487.1	12374	487.1	12374	487.1	12374	487.1	12374	592.7	15053	592.7	15053	592.7	15053
C	51.2	1300	51.2	1300	51.2	1300	51.2	1300	51.2	1300	51.2	1300	51.2	1300	51.2	1300
D	114.2	2900	114.2	2900	114.2	2900	114.2	2900	114.2	2900	114.2	2900	114.2	2900	114.2	2900
E	177.2	4502	190.6	4842	190.7	4843	190.7	4843	190.7	4843	190.7	4843	190.7	4843	190.7	4843
F	249.7	6342	291.4	7402	249.7	6342	249.7	6342	249.7	6342	249.7	6342	249.7	6342	249.7	6342
G	n/a	n/a	n/a	n/a	291.4	7402	291.4	7402	291.4	7402	291.4	7402	291.4	7402	291.4	7402
H	387.5	9842	466.2	11842	466.3	11843	466.3	11843	364.2	9250	364.2	9250	364.2	9250	364.2	9250
I	n/a	n/a	n/a	n/a	n/a	n/a	n/a	n/a	466.2	11842	502.0	12750	466.3	11843	466.3	11843
J	n/a	n/a	n/a	n/a	n/a	n/a	n/a	n/a	n/a	n/a	570.9	14500	570.9	14500	570.9	14500
K	51.2	1300	51.2	1300	51.2	1300	51.2	1300	51.2	1300	51.2	1300	51.2	1300	51.2	1300
L	114.2	2900	114.2	2900	114.2	2900	114.2	2900	114.2	2900	114.2	2900	114.2	2900	114.2	2900
M	177.2	4502	190.6	4842	190.7	4843	190.7	4843	190.7	4843	190.7	4843	190.7	4843	190.7	4843
N	249.7	6342	291.4	7402	249.7	6342	249.7	6342	249.7	6342	249.7	6342	249.7	6342	249.7	6342
O	n/a	n/a	n/a	n/a	291.4	7402	291.4	7402	291.4	7402	291.4	7402	291.4	7402	291.4	7402
P	387.5	9842	446.5	11342	446.5	11342	446.5	11342	364.2	9250	364.2	9250	364.2	9250	364.2	9250
Q	n/a	n/a	n/a	n/a	n/a	n/a	n/a	n/a	446.6	11343	502.0	12750	446.6	11343	446.6	11343
R	n/a	n/a	n/a	n/a	n/a	n/a	n/a	n/a	n/a	n/a	570.9	14500	570.9	14500	570.9	14500
S	58.3	1482	58.3	1482	58.3	1482	58.3	1482	58.3	1482	58.3	1482	58.3	1482	58.3	1482
T	85.4	2169	85.4	2169	85.4	2169	85.4	2169	85.4	2169	85.4	2169	85.4	2169	85.4	2169
U	158.5	4026	79.7	2024	79.7	2024	79.7	2024	79.7	2024	79.7	2024	79.7	2024	79.7	2024
V	n/a	n/a	184.5	4686	184.5	4686	184.5	4686	184.5	4686	184.5	4686	184.5	4686	184.5	4686
W	n/a	n/a	n/a	n/a	n/a	n/a	n/a	n/a	n/a	n/a	131.2	3550	131.2	3550	131.2	3550

(a) Condenser length defined by model number digit 25: 7V = D; 8V = E.

(b) Free Cooling defined by model number digit 42: T = TDFC; H = DFPC; F = TIFC; E = IFCP.

(c) Pump Package defined by model number digit 40 = 5, 6, 7.

Table 28. Unit Dimensions – 300 ton units, extended length, with seismic option

Cond Length ^(a)	8V			
	None		TDFC	
Free- Cooling ^(b)	None		None	
Pump Option ^(c)	None		None	
Dim	in	mm	in	mm
A	493.0	12523	493.0	12523
B	487.1	12374	487.1	12374
C	51.2	1300	51.2	1300
D	114.2	2900	114.2	2900
E	190.6	4842	190.7	4843
F	291.4	7402	291.4	7402
G	364.2	9250	364.2	9250
H	466.2	11842	466.2	11842
I	n/a	n/a	n/a	n/a
J	n/a	n/a	n/a	n/a
K	51.2	1300	51.2	1300
L	114.2	2900	114.2	2900
M	190.6	4842	190.7	4843
N	291.4	7402	291.4	7402
O	364.2	9250	364.2	9250
P	446.5	11342	446.5	11342
Q	n/a	n/a	n/a	n/a
R	n/a	n/a	n/a	n/a
S	58.3	1482	58.3	1482
T	85.4	2169	85.4	2169
U	79.7	2024	79.7	2024
V	184.5	4686	184.5	4686
W	n/a	n/a	n/a	n/a

Note: Seismic is defined by model number digit 36 = B or E.

(a) Condenser length defined by model number digit 25: 7V = D; 8V = E.

(b) Free Cooling defined by model number digit 42: T = TDFC; H = DFPC; F = TIFC; E = IFCP.

(c) Pump Package defined by model number digit 40 = 5, 6, 7.



Dimensions and Weights

Table 29. Water connection dimensions — 150 to 300 ton units, extended length, without free-cooling or pump package

Unit Size (tons)	150, 165		180, 200		225, 250		275, 300	
	in	mm	in	mm	in	mm	in	mm
X	20.4	519.5	19.6	497.5	21.8	553.6	20.6	522.5
Y	17.7	449.5	15.4	390.5	17.6	446.6	16.1	407.7
Z	49.3	1252.5	49.9	1268.0	49.9	1268.0	51.3	1303.3
AA	38.5	977.5	37.9	962.0	37.9	962.0	36.5	927.3
AB	19.3	489.5	17.6	447.5	19.8	503.6	18.2	462.5
AC	19.7	499.5	18.2	462.5	20.4	518.6	18.9	480.5
AD	229.3	5824.2	231.0	5867.4	231.0	5867.4	231.2	5872.5
AE	123.1	3126.7	122.1	3101.3	122.1	3101.3	122.1	3101.3
AF	227.9	5793.7	229.1	5819.1	229.1	5819.1	229.9	5839.5

Figure 12. Water connection dimensions – 150 to 300 ton units with free-cooling or pump package option

DIRECT FREE COOLING OPTION

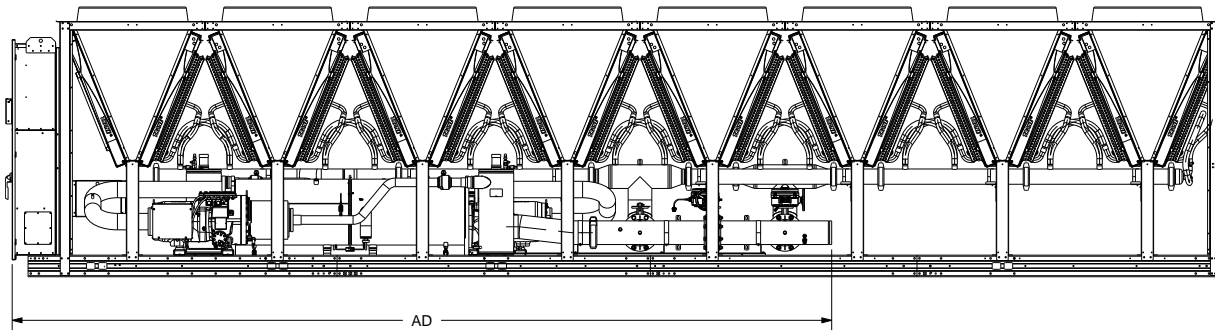

INDIRECT FREE COOLING OPTION

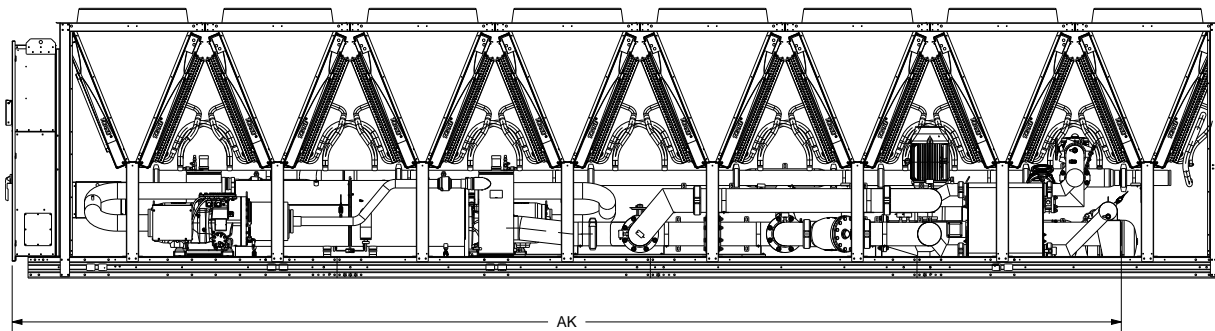

FREE COOLING OPTIONS

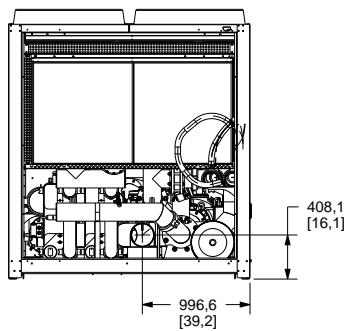

PUMP PACKAGE OPTIONS
INLET AND OUTLET/ 2PASS AND 3PASS

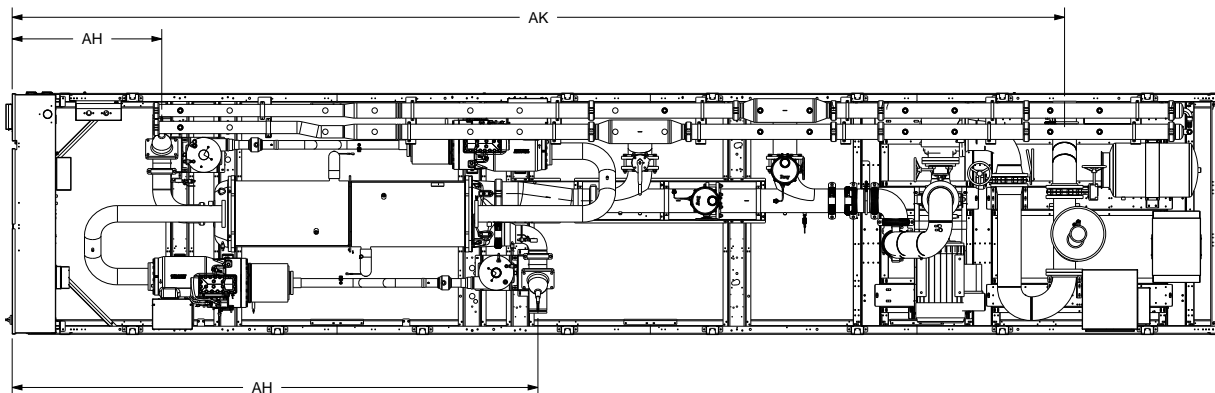
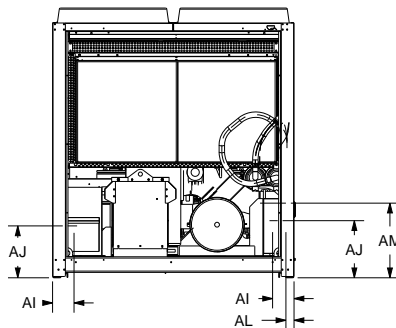



Dimensions and Weights

Table 30. Water connection dimensions – 150 to 300 ton units with free-cooling (no pump package)

Unit Size (tons)	165		180, 200		225, 250		275		300	
	in	mm	in	mm	in	mm	in	mm	in	mm
Standard Length										
X	20.4	519.5	19.6	497.5	21.8	553.6	20.6	523.2	20.6	523.2
Z	49.3	1252.5	49.9	1268.0	49.9	1268.0	51.3	1303.0	51.3	1303.0
AC	19.7	499.5	18.2	462.5	20.4	518.6	18.9	480.1	18.9	480.1
AD ^(a)	270.9	6881.6	270.9	6880.9	270.9	6880.9	298.8	7588.3	298.8	7588.3
AE	70.3	1785.6	69.2	1757.7	69.2	1757.7	69.3	1760.2	69.3	1760.2
AF	176.2	4475.5	176.2	4475.5	176.2	4475.5	177.1	4498.3	177.1	4498.3
AG	270.9	6880.9	270.9	6880.9	270.9	6880.9	298.8	7588.3	298.8	7588.3
AK ^(b)	n/a	n/a	n/a	n/a	n/a	n/a	n/a	n/a	404.1	10264.2
Extended Length^(c)										
X	20.4	519.5	19.6	497.5	21.8	553.6	20.6	523.2	20.6	523.2
Z	49.3	1252.5	49.9	1268.0	49.9	1268.0	51.3	1303.0	51.3	1303.0
AC	19.7	499.5	18.2	462.5	20.4	518.6	18.9	480.1	18.9	480.1
AD ^(a)	323.7	8222.0	323.7	8222.0	323.7	8222.0	351.6	8930.4	351.6	8930.4
AE	123.1	3126.7	122.0	3099.8	122.0	3099.8	122.0	3099.8	122.0	3099.8
AF	228.0	5791.2	229.1	5819.1	229.1	5819.1	229.1	5819.1	229.1	5819.1
AG	323.7	8222.0	323.7	8222.0	326.5	8293.1	351.6	8930.4	351.6	8930.4
AK ^(b)	n/a	n/a	n/a	n/a	n/a	n/a	n/a	n/a	456.9	11606.2

Note: Free-cooling defined by model number digit 42: T = TDFC; H = DFCP; F = TIFC; E = IFCP.

^(a) Only applicable on units with direct free-cooling cooling option (model number digit 42 = T or H).

^(b) Only applicable on units with indirect free-cooling cooling option (model number digit 42 = F or E).

^(c) Extended Length is required for voltages 200V, 230V, 575V model number digit 9 = A,B,F and harmonic filtration model number digit 44 = L.

Table 31. Water connection inlet dimensions – 300 ton unit with pump package option

Unit Option	Indirect Free-Cooling		Direct Free-Cooling	
	in	mm	in	mm
Standard Length				
AK	489.0	12419.7	383.5	9741.0
AL	3.0	75.0	2.9	72.6
AM	27.2	691.3	27.2	690.8
Extended Length^(a)				
AK	541.9	13763.7	436.3	11081.0
AL	3.0	75.0	2.9	72.6
AM	27.2	691.3	27.2	690.8

Note: Free-cooling defined by model number digit 42: T = TDFC; H = DFPC; F = TIFC; E = IFPC.

^(a) Extended Length is required for voltages 200V, 230V, 575V model number digit 9 = A,B,F and harmonic filtration model number digit 44 = L.

Table 32. Water connection outlet dimensions – 300 ton unit with pump package option

Unit Option	50HP 2-Pass		60HP or 75HP 2-Pass		50HP 3-Pass		60HP or 75HP 3-Pass	
	in	mm	in	mm	in	mm	in	mm
Standard Length								
AH	54.5	1384.5	52.3	1327.4	191.6	4866.4	193.4	4913.1
AI	7.7	196.0	8.0	203.8	7.7	196.1	0.6	15.5
AJ	20.8	528.6	19.8	503.2	18.9	480.2	18.9	480.2
Extended Length^(a)								
AH	244.4	6208.4	246.3	6255.1	107.3	2726.5	105.1	2669.4
AI	7.7	196	8	203.8	7.7	196.1	0.6	15.5
AJ	20.8	528.9	19.8	503.5	18.9	480.5	18.9	480.5

Note: Pump Package defined by model number digit 40 = 5 (50 HP), 6 (60 HP), 7 (75 HP). Pass options are defined by model number digits 19 and 20 (C2 or D2 are 2-pass, C3 is 3-pass).

^(a) Extended Length is required for voltages 200V, 230V, 575V model number digit 9 = A,B,F and harmonic filtration model number digit 44 = L.



Dimensions and Weights

Unit Sizes – Units Larger than 300 tons

Figure 13. Dimensions – units larger than 300 tons, units without direct-free cooling

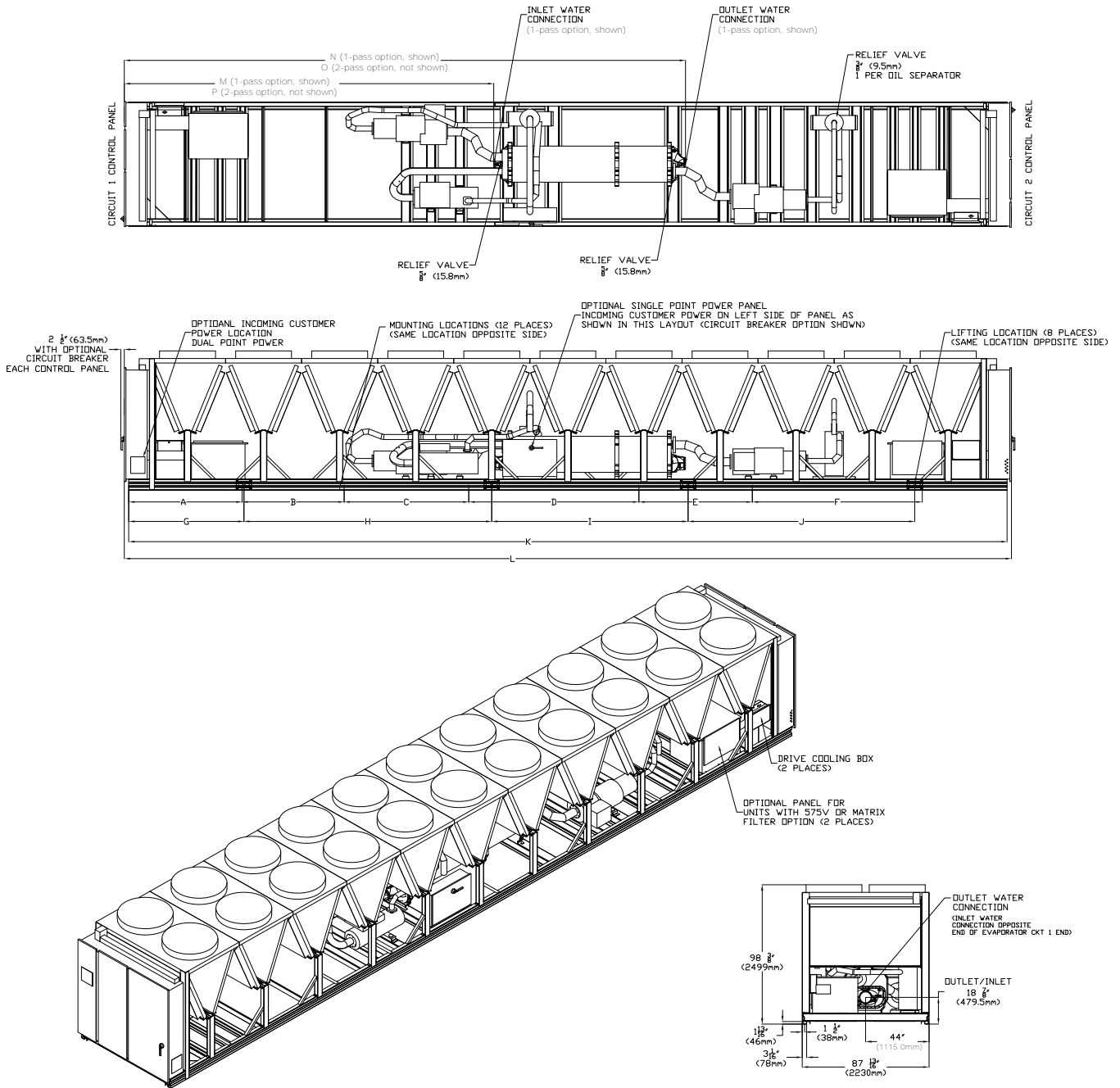

Table 33. Dimensions – units larger than 300 tons

Unit Size (tons)	375, 440		375, 440		380, 450		500, 550	
Unit Voltage^(a)	All except 575V		575V		All		All	
Harmonic Filter^(b)	Standard		Low		Low and Standard		Low and Standard	
Dimension	in	mm	in	mm	in	mm	in	mm
A	55.1	1400	78.7	2000	78.7	2000	78.7	2000
B	102.4	2600	149.6	3800	149.6	3800	149.6	3800
C	183.4	4658	236.2	6000	236.2	6000	236.2	6000
D	301.5	7658	354.3	9000	354.3	9000	354.3	9000
E	498.3	9658	433.1	11000	433.1	11000	433.1	11000
F	n/a	n/a	551.2	14000	551.2	14000	551.2	14000
G	80.0	2032	80.0	2032	80.0	2032	80.0	2032
H	199.2	5060	252.0	6402	252.0	6402	252.0	6402
I	335.6	8525	388.5	9867	388.5	9867	388.5	9867
J	446.9	11350	545.4	13852	545.4	13852	545.4	13852
K	504.3	12810	610.0	15494	610.0	15494	610.0	15494
L	510.4	12965	616.1	15648	616.1	15648	616.1	15648
M	200.7	5098	200.7	5098	253.5	6440	253.5	6440
N	333.9	8480	333.9	8480	386.7	9822	389.8	9902
O	200.7	5098	200.7	5098	253.5	6440	253.5	6440
P	200.7	5098	200.7	5098	253.5	6440	253.5	6440

^(a) Unit voltage defined by model number digit 9: 575V = F.

^(b) Harmonic filter defined by model number digit 44: STANDARD = X; LOW = L.

Dimensions and Weights

Figure 14. Dimensions – units larger than 300 tons, with direct free-cooling option

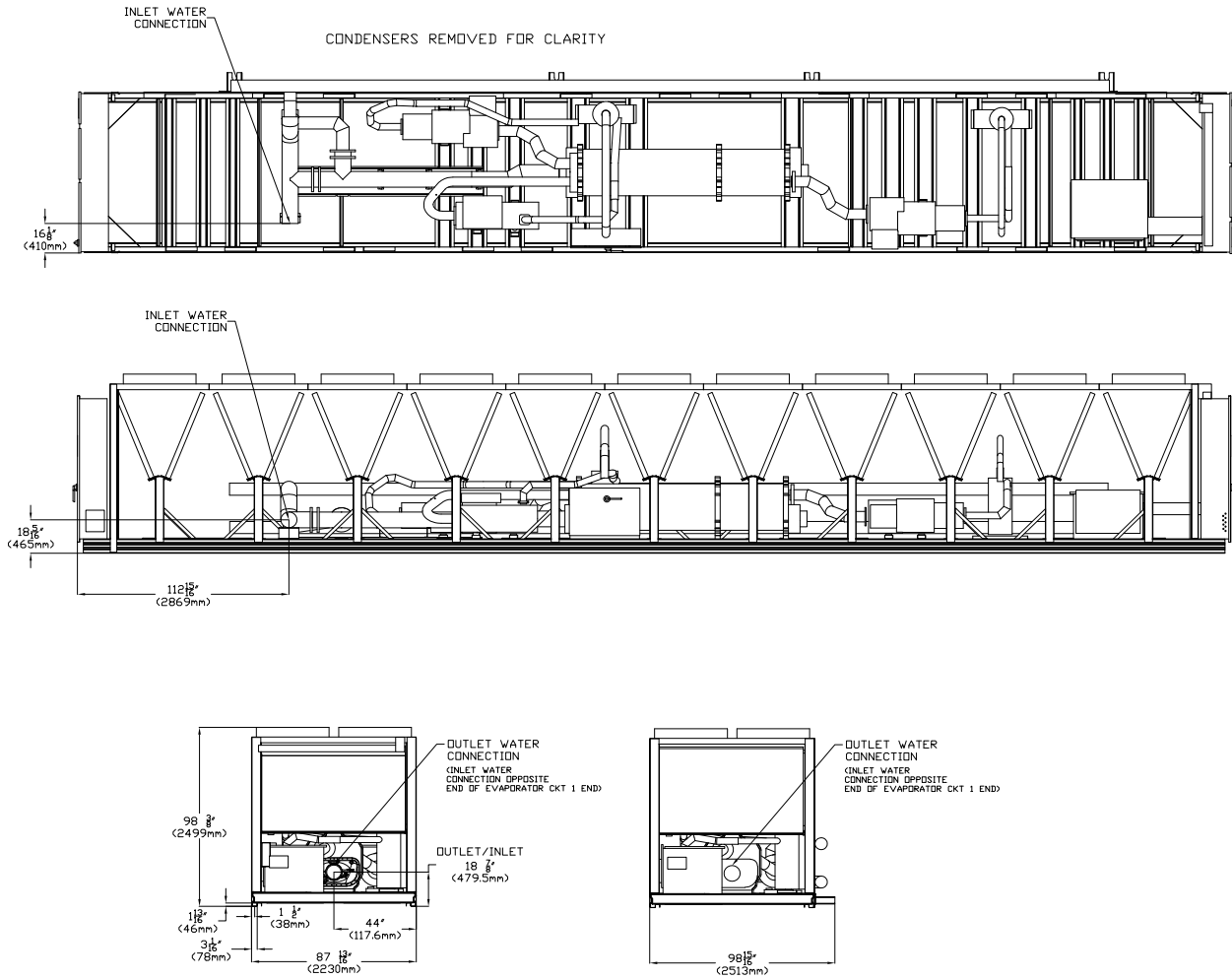

Note: Dimensions not shown remain the same as units without direct free-cooling option.



Mechanical Specifications

Certified AHRI Performance

Trane air-cooled chillers are rated within the scope of the Air-Conditioning, Heating & Refrigeration Institute (AHRI) Certification Program and display the AHRI Certified® mark as a visual confirmation of conformance to the certification sections of AHRI Standard 550/590 (I-P) and ANSI/AHRI Standard 551/591 (SI). The applications in this catalog specifically excluded from the AHRI certification program are:

- Custom Units
- Units produced outside of the USA for installations outside the USA
- Evaporatively-cooled chillers
- Units with evaporators that use fluid other than fresh water except units containing freeze protection fluids in the evaporator with a leaving chilled fluid temperature above 32°F [0°C] are certified when rated per the Standard with water.

Refrigeration Circuits

All chiller sizes are designed with two refrigerant circuits.

Each refrigeration circuit includes one or two rotary screw compressor(s), a compressor suction and discharge service valve(s), liquid line shutoff valve(s), removable core filter(s), liquid line sight glass with moisture indicator(s), charging port and an electronic expansion valve(s). Fully modulating variable volume ratio compressors and electronic expansion valves provide variable capacity modulation over the entire operating range.

Evaporator

The evaporator is a tube-in-shell heat exchanger design constructed from carbon steel shells and tubesheets with internally and externally finned seamless copper tubes mechanically expanded into the tube sheets. The evaporator is designed, tested and stamped in accordance with the ASME Boiler and Pressure Vessel Code for a refrigerant side working pressure of 200 psig. The evaporator is designed for a water side working pressure of 150 psig. Standard water connections are grooved for Victaulic style pipe couplings, with groove to flange style adapters available.

Available pass and tube arrangements vary with unit size.

- For 150 to 300 ton units, waterboxes are available in 2 and 3 pass configurations
- For units larger than 300 tons, multiple tube types are available to allow tailoring of waterside pressure drop to a wide range of flow conditions. Waterboxes are available in 1 and 2 pass configurations.

All waterboxes include a vent, a drain and fittings for temperature control sensors.

Evaporators are insulated with 3/4 inch closed cell insulation. Evaporator water heaters with thermostat are provided to help protect the evaporator from freezing at ambient temperatures down to -20°F (-29°C). A factory installed flow switch is installed on the supply waterbox in the evaporator inlet connection.

Condenser and Fans

Condenser configuration is dependent on unit size.

- For 150 to 300 ton units, air-cooled condenser coils have aluminum fins mechanically bonded to internally finned seamless copper tubing. The condenser coil has an integral subcooling circuit. Condensers are factory proof and leak tested. The copper to aluminum connections are protected against galvanic corrosion. Corrosion resistant coil coating is available if the installation site is near the ocean or in an otherwise corrosive environment. See Options chapter.



Mechanical Specifications

- For units larger than 300 tons, the air-cooled microchannel condenser coils use all aluminum brazed fin construction. The condenser coil has an integral subcooling circuit. The maximum allowable working pressure of the condenser is 350 psig. Condensers are factory proof and leak tested at 525 psig. Coils can be cleaned with high pressure water.

Condenser fans are direct-drive vertical discharge. The condenser fan motors are permanent magnet motors with integrated drive to provide variable speed fan control for all fans and are designed with permanently lubricated ball bearings, internal temperature and current overload protection, and customer fault feedback as a standard product offering. The fan impeller is a nine bladed-shrouded fan made from heavy-duty molded plastic.

Compressor and Lube Oil System

The rotary screw compressors used on 150 to 300 ton units are variable volume ratio semi-hermetic, direct drive with capacity control via a variable speed drive, rolling element bearings, differential refrigerant pressure oil flow and oil heater. The motor is a suction gas cooled, hermetically sealed, permanent magnet motor. An oil separator is provided separate from the compressor. Oil filtration is provided internal to the compressor.

For units larger than 300 ton, circuits may include a second rotary screw compressor. This secondary compressor is semi-hermetic, direct drive, with rolling element bearings, differential refrigerant pressure oil flow, and oil heater. The motor is a suction gas cooled, hermetically sealed, two-pole squirrel cage induction motor.

Drive Cooling System

Each refrigeration circuit has a compressor drive cooling circuit. Each drive cooling circuit includes a wet rotor circulation pump that circulates a secondary heat transfer fluid in a closed system between the adaptive frequency drive components in the control panel and a brazed plate heat exchanger. The pump is fed from a thermal expansion tank with a vented-pressure cap which is also used as the circuit pressure relief. Pressure relief for the drive cooling loop is set at 16 psig. The circuit also includes a particulate strainer and a drain valve for servicing.

Unit Controls

All unit controls are housed in an outdoor rated weather tight enclosure with removable plates to allow for customer connection of power wiring and remote interlocks. All controls, including sensors, are factory mounted and tested prior to shipment.

Microcomputer controls provide all control functions including startup and shut down, leaving chilled water temperature control, evaporator flow proving, compressor staging and speed control, electronic expansion valve modulation, condenser fan sequencing and speed control, anti-recycle logic, automatic lead/lag compressor starting, and load limiting.

Symbio 800 Controller

The Symbio™ 800 controller is an application-specific, programmable controller that is factory installed and designed to control packaged HVAC equipment. A 7" user interface features a touch-sensitive color screen that provides facility managers with at-a-glance operating status, performance monitoring, scheduling changes and operating adjustments. Other advanced features include automated controller backup and optional features such as secure remote connectivity, wireless building communications, and custom programming with expandable I/O.

The Symbio™ 800 control module, utilizing Adaptive Control™™ microprocessor, automatically takes action to avoid unit shut-down due to abnormal operating conditions associated with low refrigerant pressure, high condensing pressure, AFD/Compressor current overload, low oil return or low AFD cooling, low discharge superheat, and high compressor discharge temperature. Should the abnormal operating condition continue until a protective limit is violated, the unit will be shut down.

Unit protective functions of the controller include: loss of chilled water flow, evaporator freezing, loss of refrigerant, low refrigerant pressure, high refrigerant pressure, high compressor motor temperature, and loss of oil to the compressor.

BACnet Communication Protocol

The Symbio™ 800 controller shall support standard BACnet communication protocol through a RS485, two-wire communication link or BACnet/IP over Ethernet.

Trane LonTalk Communication Protocol

The LonTalk module shall provide an interface to a Tracer building automation system or other control system that supports LonTalk and shall be factory installed, allowing for control and monitoring of the unit through a RS485, two-wire communication link. Requires an additional LonTalk® Communication Kit be installed.

Modbus Communication Protocol

The Symbio™ 800 controller shall support standard Modbus® RTU communication protocol through an RS485, two-wire communication link.

Controls Expansion Hardware

Symbio™ 800 shall have field applied controls capability. Factory installed expansion hardware (XM70) shall have 19 inputs/outputs. Additional expansions may be added in the field.

Tracer AdaptiView TD7 Display

A full color Tracer AdaptiView™ TD7 touch screen display indicates all important unit and circuit parameters, in logical groupings on various screens. The parameters including chilled water set point, leaving chilled water temperature, demand limit set point, evaporator and condenser refrigerant temperatures and pressures, compressor and fan speeds, and all pertinent electrical information. The display also provides “on screen” trending graphs of predefined parameters as well as customizable trend graphs based on user defined parameters from a list of all available parameters. The display also provides indication of the chiller and circuits’ top level operating modes with detailed sub-mode reports available with a single key press, as well as diagnostics annunciation and date and time stamped diagnostic history. The color display is fully outdoor rated, and, can be viewed in full daylight without opening any control panel doors.

Standard power connections include main three phase power to the compressors, condenser fans and control power transformer and optional connections are available for the 115 volt/60 Hz single phase power for the thermostatically controlled evaporator heaters for freeze protection.

- Outdoor capable:
 - UV Resistant Touchscreen
 - -40°C to 70°C Operating Temperature
 - IP56 rated (Power Jets of Water from all directions)
- RoHS Compliant
- UL 916 Listed
- CE Certification
- Emissions: EN55011 (Class B)
- Immunity: EN61000 (Industrial)
- Display:
 - 7 inch diagonal
 - 800x480 pixels
 - TFT LCD @ 600 nits brightness
 - 16 bit color graphic display
- Display Features:
 - Alarms
 - Reports
 - Unit Settings
 - Display Settings



Mechanical Specifications

- Graphing
- Global Application with Support for 27 Languages

Adaptive Frequency Drive

The compressors on the ACR chillers are driven by Adaptive Frequency Drives (AFD). The drives are hybrid cooled by both water/glycol through the chillplate to cool the power electronics and also forced air for other components in the drive. The drives include custom programming for Trane application to provide chiller specific protections and stable compressor operation across the operating map. Protections include compressor overload, low or high line voltage, output phase loss, input phase loss, drive overheating, and more. The drives communicate over a serial connection (Modbus) to the Symbio™ 800 unit control module for run-time control, real-time data feedback, and diagnostics.

Chilled Water Reset

Control logic and factory installed sensors are provided to reset leaving chilled water temperature. The set point can be reset based on ambient temperature or return evaporator water temperature.

Factory Mounted Flow Proving

The factory installed evaporator water flow switch is provided with the control logic to turn the chilled water flow on and off as the chiller requires for operation and protection. This function is a requirement on the chiller.

Factory Mounted Flow Measurement

The factory mounted flow measurement system is provided to give a flow output to the display and customer BAS. The flow measurement is not used to control the chiller. This option is only available if a factory mounted pump package is ordered. The installed flow measurement system requires calibration at start up.



Options

Application Options

Free-Cooling

The free-cooling option delivers optimal performance by minimizing compressor operation when outdoor air temperatures are low enough to assist in cooling the chilled fluid loop.

Notes:

- *Glycol solution must be utilized in the customer chilled fluid loop for the direct free-cooling options, digit 42 = T or H and in the indirect free cooling internal chiller loop, digit 42 = E or F.*
- *Glycol concentration should be based on ambient freeze avoidance.*
- *Direct free-cooling, digit 42 = T or H only, can operate down to -40°F (-40°C). This is independent of the mechanical cooling low ambient operating limits.*
- *Indirect free cooling, digit 42 = E or F, braze plate heat exchangers and water pipes come with 3/4 inch closed cell insulation and heaters with a thermostat to help protect them from freezing at ambient temperatures down to -20°F (-29°C).*

Ice Making

The ice making option provides special control logic to handle low temperature brine applications (less than 40°F [4.4°C] leaving evaporator temperature) for thermal storage applications.

Low Temperature Fluid

Low temperature option provides special control logic to handle low temperature brine applications including part load conditions below 40°F (4.4°C) leaving evaporator temperature.

Low Ambient Option

The low ambient options adds hardware and unit controls to allow start and operation down to ambient temperatures of 0°F (-17.7°C).

Extreme Low Ambient Option

The extreme low ambient option adds hardware and unit controls to allow operation down to ambient temperatures of -16°F (-26.7°C).

High Ambient Option

High ambient option consists of special control logic, compressor motors, and variable speed drives to permit high ambient (up to 125°F [51°C]) operation. Low side ambient remains 32°F (0°C).

Wide Ambient Option

The wide ambient option combines the features of low and high ambient options for an ambient range of 0 to 125°F (-17.7 to 51°C).

Electrical Options

Circuit Breaker

A HACR rated molded case capacity circuit breaker (UL approved) is available. Circuit breaker can also be used to disconnect chiller from main power with a through-the-door handle.



Harmonic Attenuation

Harmonic attenuation to comply with IEEE 519 and achieving 5% TDD when ISC/ILOAD < 20. (Reference IEEE-519-2014, table 2.) It is important to recognize that IEEE 519 as a guideline relates to the entire system, not specifically to any one load or product. IEEE 519 establishes requirements at the point of common coupling (PCC) where the building connects to the utility system. The standard contains no specific requirements for the internal electrical loads. Even though Trane AFD-equipped chillers will attenuate their own harmonics, other nonlinear loads on the same system could still create harmonic problems. In buildings where harmonics might be a concern, Trane recommends conducting a power-distribution system analysis to determine if there is a need to further attenuate harmonics at the system level.

Control Options

BACnet Communications Interface

Allows the user to easily interface with BACnet® via a single twisted pair or Ethernet wiring to a factory installed and tested communication board.

ModBus Communications Interface

Allows the user to easily interface with ModBus™ via a single twisted pair wiring to a factory installed and tested communication board.

LonTalk Communications Interface

Provides the LONMARK® chiller profile inputs/outputs for use with a generic building automation system via a single twisted pair wiring to a factory installed and tested communication board.

Remote Input Options

Option permits remote chilled liquid setpoint, remote demand limit setpoint, or both by accepting a 4-20 mA or 2-10 Vdc analog signal.

Remote Output Options

Permits alarm relay outputs, chiller Percent Capacity via a 2–10VDC signal, or both.

Sound Options

InvisiSound Standard

For InvisiSound® Standard option, each variable speed rotary screw compressor will have a muffler as standard and each condenser fan will be low noise as standard.

InvisiSound Standard with Noise Reduction (units larger than 300 tons only)

For InvisiSound Standard with Noise reduction, each variable speed rotary screw compressor will have a muffler as standard, and reduces the maximum speed (adjustable) of the condenser fans.

InvisiSound Superior

In addition to the sound reducing features on the InvisiSound Standard , Superior adds insulating sound material to the suction and discharge lines of each refrigerant circuit, a pre-formed “sound box” encapsulating each compressor, and slightly reduces the maximum speed (adjustable units on larger than 300 tons) of the condenser fans.

InvisiSound Superior with Noise Reduction (units larger than 300 tons only)

In addition to the sound reducing features on the InvisiSound Standard , Superior with Noise Reduction adds insulating sound material to the suction and discharge lines of each refrigerant circuit, a pre-formed “sound box” encapsulating each compressor, and reduces the maximum speed (adjustable) of the condenser fans.

InvisiSound Ultimate (150 to 300 ton units only)

In addition to the sound reducing features on the Superior option, the Ultimate unit adds a flexible, metallic connection at the suction and discharge of each compressor, a pre-formed "sound box" encapsulating each compressor, and reduces the maximum speed (adjustable) of the condenser fans.

Other Options

Architectural Louvered Panels

Louvered panels cover the complete condensing and free cooling coils and service area beneath the coil box assembly.

Coil Corrosion Protection

CompleteCoat™ is available on all size units for corrosion protection. Job site conditions should be considered to determine the need to order coating to inhibit coil corrosion and ensure extended equipment life. CompleteCoat™ option provides fully assembled coils with a flexible dip and bake epoxy coating.

Convenience Outlet

Depending on the specific build, this option provides either a 15A or 20A, 115V 60Hz, convenience outlet on the unit. On non-free cooling units, the electrical contractor must make a separate connection to this device. On free cooling units, this connection is already factory made. See model number and submittal for details.

Flanged Water Connection Kit

Provides raised face flanges to convert grooved pipe evaporator water connections to flange connectors.

Insulation for High Humidity

The evaporator is covered with factory-installed 1.25 inch (31.8 mm) Armaflex II or equal (k=0.28) insulation.

Isolators — Elastomeric

Elastomeric Isolators provide isolation between chiller and structure to help eliminate vibration transmission. Elastomeric isolators are required with the InvisiSound™ Ultimate option.

Seismically Rate Unit - IBC

Unit is built and certified for seismic applications in accordance with the following International Building Code (IBC) release 2018.

Wind Load for Florida Hurricane

Unit is built and certified to meet the requirements of the 2020 Florida Building Code Seventh Edition per ASCE 7 for 186 MPH wind speed, Exposure 'C', Risk Category III. This unit is certified for both ground mounted units, and units mounted on rooftops up to 60 ft.

Neoprene Isolator Pads

Isolators provide isolation between chiller and structure to help eliminate vibration transmission. Neoprene isolator pads are required when purchasing a seismically certified unit.

Single High Head Pump Package

The pump package contains a single pump, triple duty valves, service isolation valves, pressure ports, air separator, expansion tank, and fluid strainer. -20 °F (-29 °C) ambient freeze protection for water is included.



Options

The pump skid contains an independent pump motor starter panel. The pump starter panel's power supply is prewired into the chiller's control panel assembly, an independent pump motor power supply is not required. Variable pump speed command is integrated with the chiller controller allowing variable flow functionality. Harmonic filtration is standard.

Pump package applications include short loops, decoupled systems and service for an entire loop volume. Because the fluid distribution system beyond the chiller is unknown, Trane Select Assist reports Available Head as the head leaving the chiller at the system supply connection point. Available Head includes the evaporator head loss, pump package and free cooling piping frictional effects head losses, valve head losses, air separator head loss, and strainer head loss summation.

The pump package should not be operated at $NPSH_R$. Operation at this suction head will cause cavitation. $NPSH_A$ should be at least 1.5 to 2.5 times $NPSH_R$.



The AHRI Certified mark indicates Trane U.S. Inc. participation in the AHRI Certification program. For verification of individual certified products, go to ahridirectory.org.

Trane - by Trane Technologies (NYSE: TT), a global innovator - creates comfortable, energy efficient indoor environments for commercial and residential applications. For more information, please visit trane.com or tranetechnologies.com.

Trane has a policy of continuous product and product data improvements and reserves the right to change design and specifications without notice. We are committed to using environmentally conscious print practices.