

providing insights for today's hvac system designer

Engineers Newsletter

volume 46-2

Dedicated Outdoor Air System with Sensible-Cooling Terminal Units

As buildings continue to be designed for lower energy use, the resulting reduction in sensible cooling loads presents an economically feasible opportunity for systems that use zone-level, sensible-only cooling equipment. Examples include radiant cooling panels (or tubing embedded in the building structure), chilled beams, and terminal units with sensible-only cooling coils. The common function of these devices is that they are used to provide sensible cooling only, and are not able to provide any dehumidification (no condensation).

This *Engineers Newsletter* describes one such system that uses chilled-water, sensible-cooling terminal units.

System Overview

In this system, the outdoor air required for ventilation is conditioned by a dedicated outdoor-air unit. This unit filters, cools, dehumidifies, heats, and may even humidify this outdoor air before distributing it through a duct system to a terminal unit serving each zone (Figure 1).

Each terminal unit is equipped with a fan and a chilled-water coil mounted at the inlet from the ceiling plenum. The conditioned outdoor air (CA) from

Figure 1. DOAS with chilled-water, sensible-cooling terminal units

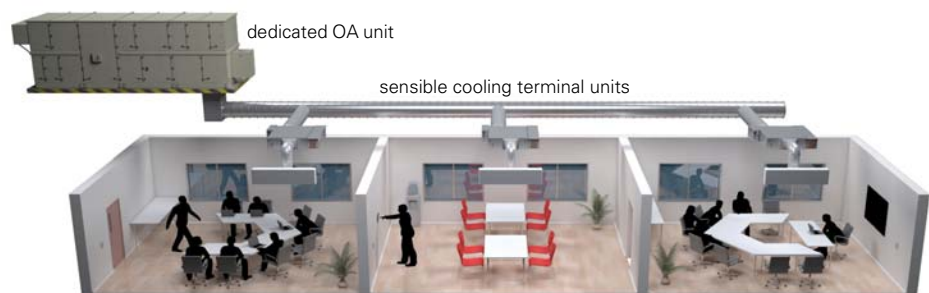

the dedicated OA unit enters each terminal unit through a flow-measuring damper (similar to, but smaller than used in a conventional VAV terminal), where it then mixes with recirculated air (RA) from the zone that has passed through the cooling coil. Finally, the terminal fan delivers this mixed supply air (SA) to the zone through downstream ductwork and diffusers (Figure 2). This fan is equipped with an electronically-commutated motor (ECM), which allows the fan speed, and therefore the supply airflow, to be varied as the zone load changes. For those zones that may require heating, a separate electric or hot-water coil may be added to the terminal unit.

The chilled water supplied to the terminal unit's cooling coil is controlled to a temperature above the zone dewpoint—typically between 56°F and 58°F—so that the cooling coil operates dry and provides only sensible cooling (no dehumidification

or condensation). Therefore, the dedicated OA unit must dehumidify the outdoor air to a dew point that is dry enough to offset the entire zone latent load (due to people and infiltration, for example) and maintain the zone dew point at or below a defined threshold—typically 55°F.

Figure 2. Example sensible-cooling terminal unit

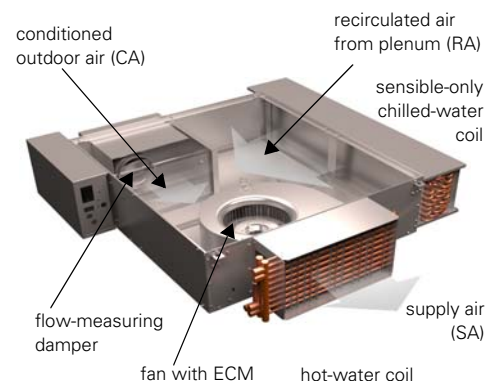

Control of Sensible-Cooling Terminal Units

Each terminal unit provides independent control of the temperature in the zone it serves, while ensuring sufficient outdoor air for ventilation. Figure 3 depicts an example of the terminal unit control sequence during Occupied Mode.

Occupied Mode, Deadband. When the zone temperature is satisfied (in the deadband between its heating and cooling setpoints, depicted by the vertical grey bar in the center of the chart), the terminal fan operates at its minimum fan airflow setpoint, with both the chilled-water and hot-water valves closed (or electric heater off). The ventilation air damper is controlled to the minimum OA setpoint.

Occupied Mode, Cooling. When the zone temperature rises to its cooling setpoint, both the terminal fan speed and chilled-water valve are modulated to maintain zone temperature at setpoint, while the hot-water valve remains closed (or electric heater remains off). Moving from the deadband in Figure 3 to the right:

- 1st stage cooling: First, the chilled-water valve is modulated further open to maintain zone temperature at its cooling setpoint, while the fan remains operating at its minimum fan airflow setpoint and the ventilation air damper remains at its minimum OA setpoint.
- 2nd stage cooling: When the requested cooling capacity has increased to the point where the chilled-water valve is 100% open, the fan speed is increased to maintain zone temperature at its cooling setpoint, while the chilled-water valve remains fully open and the ventilation air damper remains at its minimum OA setpoint.
- 3rd stage cooling ("boost" mode): If the fan reaches its maximum fan airflow setpoint, but even more cooling capacity is required, the ventilation air damper can be modulated further open (increasing the flow rate of cool, dehumidified air) to maintain zone temperature at its cooling setpoint, while the chilled-water valve remains fully open and the fan continues operating at its maximum airflow setpoint.

Figure 3. Example of sensible-cooling terminal unit control

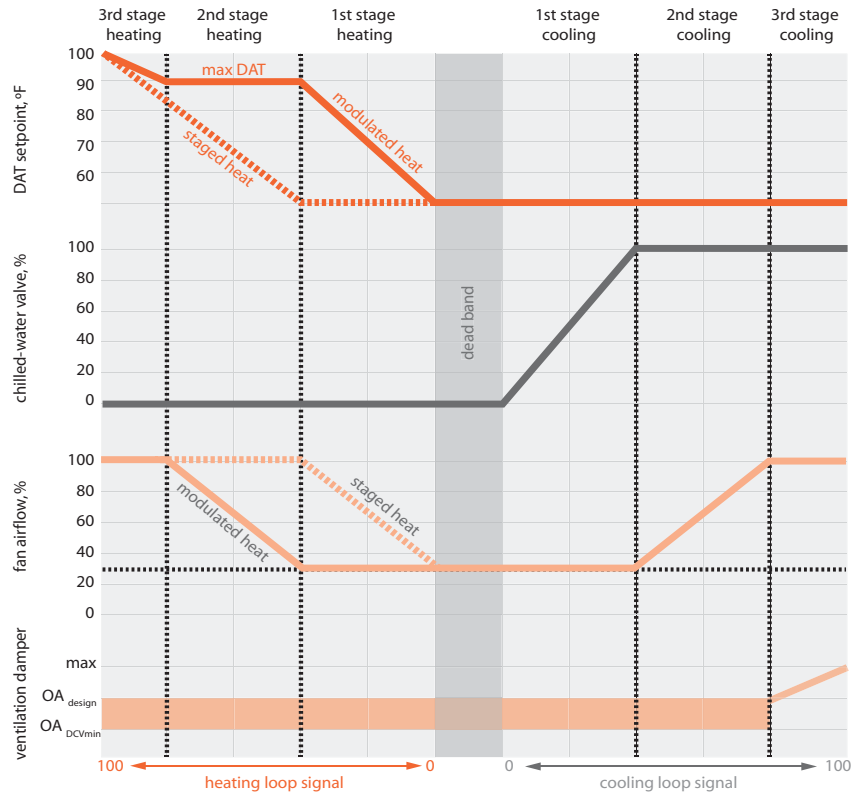

Occupied Mode, Heating. When the zone temperature drops to its heating setpoint, both the terminal fan speed and hot-water valve (or electric heater) are modulated to maintain zone temperature at setpoint, while the chilled-water valve remains closed and the ventilation air damper is controlled to the minimum OA setpoint. Moving from the deadband in Figure 3 to the left:

- 1st stage heating: First, the hot-water valve (or SCR electric heater) is modulated to maintain zone temperature at its heating setpoint, while the fan remains operating at its minimum fan airflow setpoint.
- 2nd stage heating: When the discharge air temperature (DAT) has reached the desired maximum limit (90°F, in this example), the fan speed is increased to maintain zone temperature at its heating setpoint, while the hot-water valve (or SCR electric heater) modulates to maintain DAT at this maximum limit.
- 3rd stage heating: If the fan reaches its maximum fan airflow setpoint, and more heat is still required, the hot-water valve (or SCR electric heater) can modulate further open to maintain zone temperature at its heating setpoint.

For terminal units equipped with staged electric heat, the heating sequence is reversed (depicted by dashed lines in Figure 3). First, fan speed is increased while the electric heater remains off. Then, when the fan has reached its maximum fan airflow setpoint, the electric heater is staged on to maintain zone temperature at its heating setpoint.

Demand-Controlled Ventilation.

Since the dedicated OA unit delivers 100 percent outdoor air to a flow-measuring damper in each terminal unit, implementing demand-controlled ventilation (DCV) is quite straightforward. By installing a CO₂ sensor (or an occupancy sensor), outdoor airflow delivered to the terminal unit is adjusted by modulating the ventilation air damper (Figure 3)—between the outdoor airflow required at design population (OA_{design}) and the minimum allowable outdoor airflow with DCV (OA_{DCVmin})—based on the current CO₂ concentration in the zone.

This DCV sequence can be overridden, however, if additional cooling capacity is needed (see previous discussion of 3rd stage cooling), or if additional dehumidification is needed. If a zone humidity sensor is installed and the measured zone dew point rises above the desired threshold—55°F, for example—the ventilation air damper can be modulated further open (overriding DCV and increasing the flow rate of dehumidified air) until the zone dew point drops back below this threshold.

Condensate Avoidance. While the cooling coil in the terminal unit is intended to operate dry (no condensation), a drip pan is installed underneath this coil in the event that unintended condensation does occur.

If the moisture sensor installed in this drip pan detects the presence of condensate, the chilled-water valve is closed while the terminal fan and ventilation air damper continue to operate as normal, through the 2nd and 3rd stages of cooling. The chilled-water valve is allowed to open again when condensate is no longer detected.

In addition, if a zone humidity sensor is installed and the measured zone dew point rises above the entering chilled-water temperature, the chilled-water valve is closed while the terminal fan and ventilation air damper continue to operate as normal, through the 2nd and 3rd stages of cooling. The chilled-water valve is allowed to open again when the zone dew point drops back below the entering chilled-water temperature.

Filtration. ASHRAE® Standard 62.1-2016 requires a filter, with a MERV rating of at least 8, be installed upstream of all wetted surfaces:

5.8 Particulate Matter Removal. Particulate matter filters or air cleaners having a minimum efficiency reporting value (MERV) of not less than 8 when rated in accordance with ASHRAE Standard 52.2 shall be provided upstream of all cooling coils or other devices with wetted surfaces through which air is supplied to an occupiable space. Exception: Cooling coils that are designed, controlled, and operated to provide sensible cooling only.

For this system, however, the terminal unit cooling coils are designed and operated to provide sensible cooling only. Therefore, as stated in the exception above, Standard 62.1 does not require a filter upstream of the terminal unit cooling coils.

While not required by Standard 62.1, it has the option to be equipped with a filter to clean the locally-recirculated air before it passes through the cooling coil. This provides an air cleaning benefit and keeps the coil cleaner, but it would require periodic replacement.

Dedicated OA Unit Configurations

As mentioned previously, all the outdoor air required for ventilation is conditioned by a dedicated OA unit and then distributed to a terminal unit serving each zone. To enable the chilled-water coils in the terminal units to operate dry (no condensation), the dedicated OA unit must dehumidify the outdoor air to a dew point that is dry enough to offset the entire space latent load and maintain the zone dew point at or below 55°F.

Determining Leaving-Air Dew Point (example: office space)

To compare various dedicated OA unit configurations, consider an example office building located in Jacksonville, Florida. The desired space conditions are 75°F dry bulb with 50 percent relative humidity, which equates to a 55°F indoor dew point and a humidity ratio of 64.7 gr/lb (W_{space}).

Using the default occupant density for an office (5 people/1000 ft²) from ASHRAE Standard 62.1-2016, the minimum required outdoor airflow (V_{bz}) for an office space is 17 cfm/person [(5 cfm/person) + (0.06 cfm/ft²) / (5 people/1000 ft²)]. Assuming the only latent load in the space is due to people, then the space latent load ($Q_{space,latent}$) is 200 Btu/h/person (2017 ASHRAE Handbook of Fundamentals, page 18.4, Table 1).

Therefore, to offset this space latent load ($Q_{space,latent}$) with the minimum required outdoor airflow (V_{bz}), and maintain the space humidity ratio (W_{space}) at 64.7 gr/lb, the dedicated OA unit must dehumidify the outdoor air to 47.6 gr/lb (W_{CA}), which equates to a 47°F dew point:

$$Q_{space,latent} = 0.69 \times V_{bz} \times (W_{space} - W_{CA})$$

$$200 \text{ Btu/h/person} = 0.69 \times 17 \text{ cfm/person} \times (64.7 \text{ gr/lb} - W_{CA})$$

$$W_{CA} = 47.6 \text{ gr/lb (approximately 47°F dew point)}$$

Note: The value 0.69 in the above equation is not a constant, but is derived from the properties of air at "standard" conditions. Air at other conditions and elevations will cause this factor to change.

Of course, an alternate approach could be to increase the airflow delivered by the dedicated OA unit, which would allow for a higher leaving-air dew point. But this would increase the size of the dedicated OA unit and the ductwork.

For further discussion, see the Trane "Dedicated Outdoor Air Systems" application guide (SYS-APG001-EN).¹

Figure 4. Determining DOAS leaving-air dew point

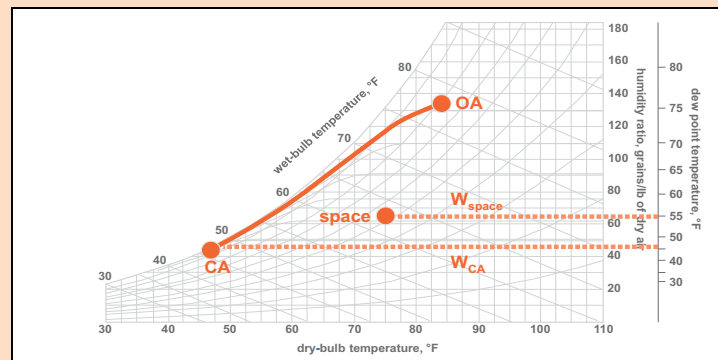

In this section, we will examine a few dedicated OA unit configurations that might be used to dehumidify the outdoor air to the required 47°F dew point in our example (see inset below). For the purpose of this EN, we will assume that a chilled-water coil in the dedicated OA unit is supplied with 40°F water to dehumidify the outdoor air to a 47°F dew point, while the sensible-cooling terminal units are supplied with 57°F water to provide sensible cooling for the zones and avoid condensation (zone dew point of 55°F plus a margin of safety).

Cooling Coil + Reheat Coil. The first configuration includes a chilled-water cooling/dehumidifying coil plus a reheat coil (Figure 5). Note that a total-energy wheel is included in all configurations, as well.

After the total-energy wheel preconditions the incoming outdoor air (transfers sensible heat and latent heat from the incoming outdoor air to the cooler, drier exhaust air), the cooling coil dehumidifies this air to the required 47°F dew point. In this example, with the exception of a few degrees of heat gain from the downstream fan, this dehumidified air is not reheated at design conditions.

Delivering this cold air (49°F) to the terminal units offsets part of the zone sensible cooling load. In this example, 20,000 cfm of this 49°F air offsets 47 tons of space sensible-cooling load, allowing the terminal fan airflows to be reduced and possibly allows for smaller cooling coils. This also allows for smaller pipes and pumps, and lower pumping energy, due to the need for less GPM to provide the remaining sensible cooling at the zone terminals.

This configuration provides the simplest and smallest footprint of the three configurations discussed in this EN. It also delivers the coldest air— 49°F, compared to 55°F or 64°F with the other two configurations—allowing for the zone-level terminals to be downsized the most (Table 1). However, delivering this cold of air requires careful attention to downstream duct insulation to prevent condensation.

A variation of this configuration is to use two separate chilled-water coils in series (Figure 6). The upstream coil is supplied with the same water produced for the

Figure 5. Dedicated OA unit #1 (cooling coil + reheat)

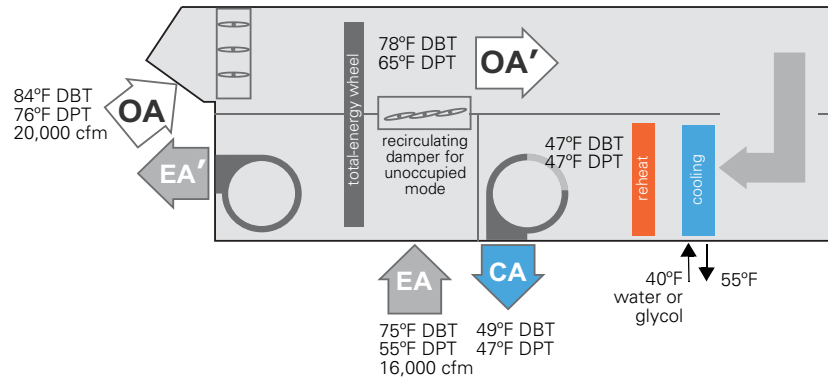

Figure 6. Dedicated OA unit #1 with two cooling coils in series

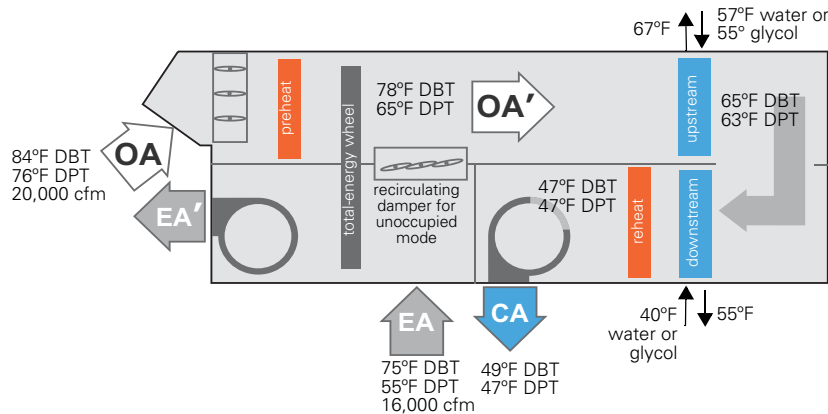
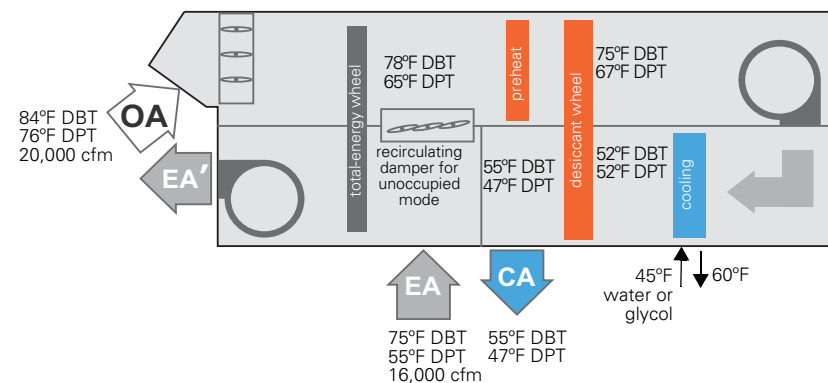

Figure 7. Dedicated OA unit #2 (cooling coil + series desiccant wheel)



sensible cooling coils in the terminal units, while the downstream coil is supplied with the colder 40°F water needed to dehumidify the outdoor air to the required 47°F dew point. The benefit of using series coils is that it shifts some of the DOAS load to the more-efficient, "warm-water" chiller. For this example, 30 tons of cooling load is provided by the

"warm-water" chiller, reducing the load on the "cold-water" chiller from 107 tons to 77 tons.

Cooling Coil + Desiccant Dehumidification Wheel. Because of the low leaving-air dew point required, this may be a good application for a series desiccant dehumidification

wheel (Figure 7). In this configuration, after the incoming outdoor air is preconditioned by the total-energy wheel, it passes through the upstream cooling coil—which need to dehumidify this air to only a 52°F dew point—and finally through the downstream side of the desiccant wheel where the air is further dehumidified to the required 47°F leaving-air dew point.

One benefit of this configuration is that it does not require the dedicated OA unit to cool the air all the way down to approximately 47°F dry bulb in order to dehumidify it to the required 47°F dew point. Therefore, the chilled water supplied to the cooling coil may not need to be as cold—only 45°F in this example, compared to 40°F without the desiccant wheel.

Another benefit is that the leaving-air dry-bulb temperature is not as cold, which may help reduce the risk of condensation on uninsulated, downstream ductwork. In this example, the conditioned outdoor air (CA) leaves the unit at 55°F dry bulb, compared to 49°F in the first configuration without a series desiccant wheel. Note, however, that delivering this air to the zone-level terminals at a warmer temperature offsets less of the zone sensible cooling load—36 tons, compared to 47 tons without the desiccant wheel—which requires higher terminal fan airflows and possibly larger cooling coils.

Of course, the desiccant wheel increases the physical size of the dedicated OA unit and it adds pressure loss in the airstream, which increases fan energy use.

This configuration could also use two chilled-water coils in series, which would shift some of the dedicated OA unit load to the more-efficient, "warm-water" chiller. In this example, this configuration allows for the smallest design load on the less-efficient, "cold-water" chiller with the other two configurations (Table 1).

Cooling Coil + Fixed-Plate Heat Exchanger. The final configuration includes a fixed-plate (sensible) heat

Figure 8. Dedicated OA unit #3 (cooling coil + fixed-plate heat exchanger)

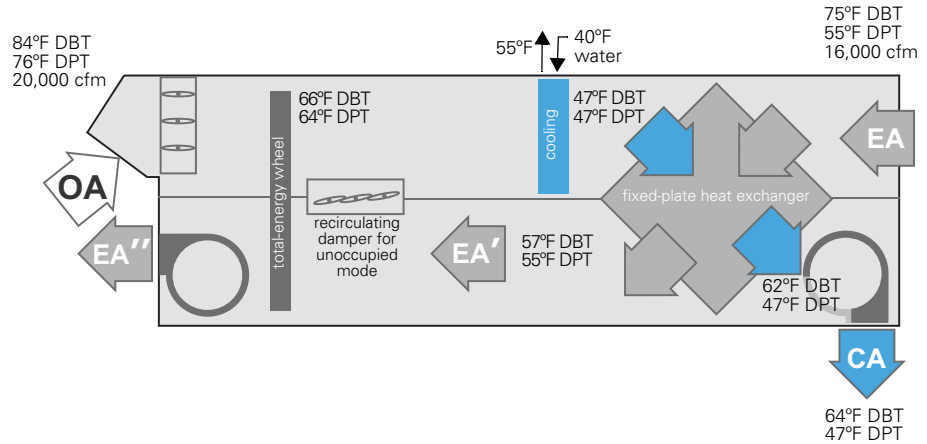

Table 1. Comparison on dedicated OA unit configurations

	unit #1 (cooling + reheat)		unit #2 (with desiccant wheel)		unit #3 (with fixed-plate HX)	
upstream cooling coil						
design load, tons	30		37		8	
supply-water temperature	55°F		55°F		55°F	
downstream cooling coil						
design load, tons	107	77	96	59	85	77
supply-water temperature	40°F	40°F	45°F	45°F	40°F	40°F
leaving-air conditions						
dry-bulb temperature	49°F	49°F	55°F	55°F	64°F	64°F
dew point temperature	47°F	47°F	47°F	47°F	47°F	47°F
sensible cooling by CA, tons	47	47	36	36	20	20
total DOAS design loads						
on "warm-water" chiller, tons	30		37		8	
on "cold-water" chiller, tons	107	77	96	59	85	77

exchanger located downstream of the cooling coil (Figure 8). After the total-energy wheel preconditions the incoming outdoor air, the cooling coil dehumidifies this air to the required 47°F dew point. This dehumidified air then passes through the heat exchanger where it is reheated (sensible heat is transferred from the warmer exhaust air) to 62°F dry bulb, in this example.

As the fixed-plate heat exchanger transfers heat to reheat the dehumidified air, it cools

the exhaust airstream from 75°F to 57°F, in this example. This improves the performance of the total-energy wheel, allowing it to pre-cool the incoming outdoor air even further. This added benefit results in the smallest design cooling load on the dedicated OA unit—85 tons compared 107 or 96 tons with the other two configurations (Table 1).

With this heat exchanger, the leaving-air dry-bulb temperature is warmer, 64°F in this example, which avoids any risk of condensation on downstream ductwork. But this warmer air does not allow the zone-level terminals to be downsized as

much as the other two configurations (Table 1).

However, the fixed-plate heat exchanger does increase the physical size of the unit, and adds pressure loss that increases fan energy use.

Finally, as with the others, this configuration could use two chilled-water coils in series.

Chiller Plant Configurations

As explained previously, the chilled water supplied to the terminal unit cooling coils must be controlled to a temperature above the zone dew point, typically in the range of 56°F to 58°F, to avoid condensation on these coils. To maintain the zone dew point at or below 55°F, the dedicated OA unit must dehumidify the outdoor air to a very low dew point—47°F for our example office space. This requires chilled water supplied to the cooling/dehumidifying coil in the dedicated OA unit to be much colder—typically in the range of 38°F to 45°F.

For the following discussion of chiller plant configurations, we will assume 57°F water is supplied to the terminal units and 40°F water is supplied to the dedicated OA unit. (See the previous EN, titled "Dual-Temperature Chiller Plants," for further discussion and comparison of various dual-temperature chiller plant configurations.²)

Plant with a Single Chiller. Many small chilled-water systems include only one water chiller. (While the diagrams in this section show an air-cooled chiller, a water-cooled chiller could be used instead.)

Intermediate heat exchanger. In the first configuration (Figure 9), the water chiller produces 40°F fluid (water or brine). Some of this fluid is distributed to the cooling coil in the dedicated OA unit; while the rest passes through a plate-and-frame heat exchanger that is controlled to produce 57°F water for the sensible-only terminal units.

Figure 9. Single-chiller, dual-temperature plant

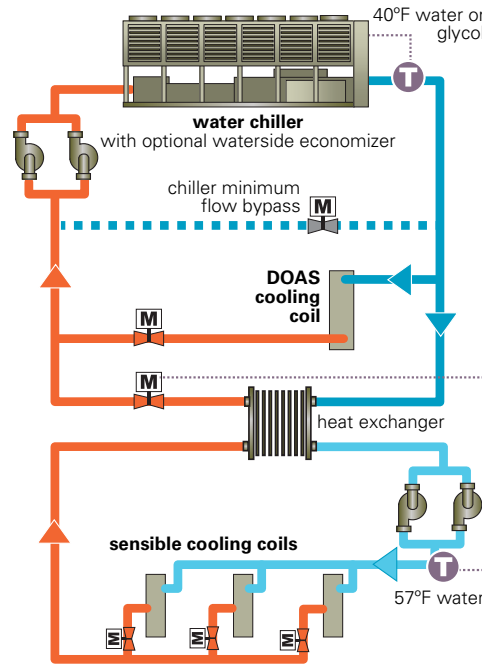

The benefit of this configuration is simplified hydronics and control. But it precludes any efficiency benefit of operating a chiller at the warmer leaving-water temperature for space sensible cooling during outdoor conditions when dehumidification is required. During drier weather, when the DOAS dehumidifying coil is no longer needed (when the outdoor dew point is below 47°F, in this example), the leaving-water temperature setpoint for the chiller can be reset up from 40°F to near 57°F.

Adding ice storage. One way to regain this efficiency advantage in a single-chiller plant is to add ice storage and configure the system as shown in Figure 10.

During **daytime operation**, the ice in the tanks is melted to produce the 40°F fluid needed by the DOAS dehumidifying coil. This allows the water chiller to raise its leaving-water setpoint (thereby increasing its efficiency) to make 57°F water for the sensible-cooling terminal units. (Note that the chiller will need to make slightly colder

Figure 10. Single-chiller, dual-temperature plant with ice storage (daytime)

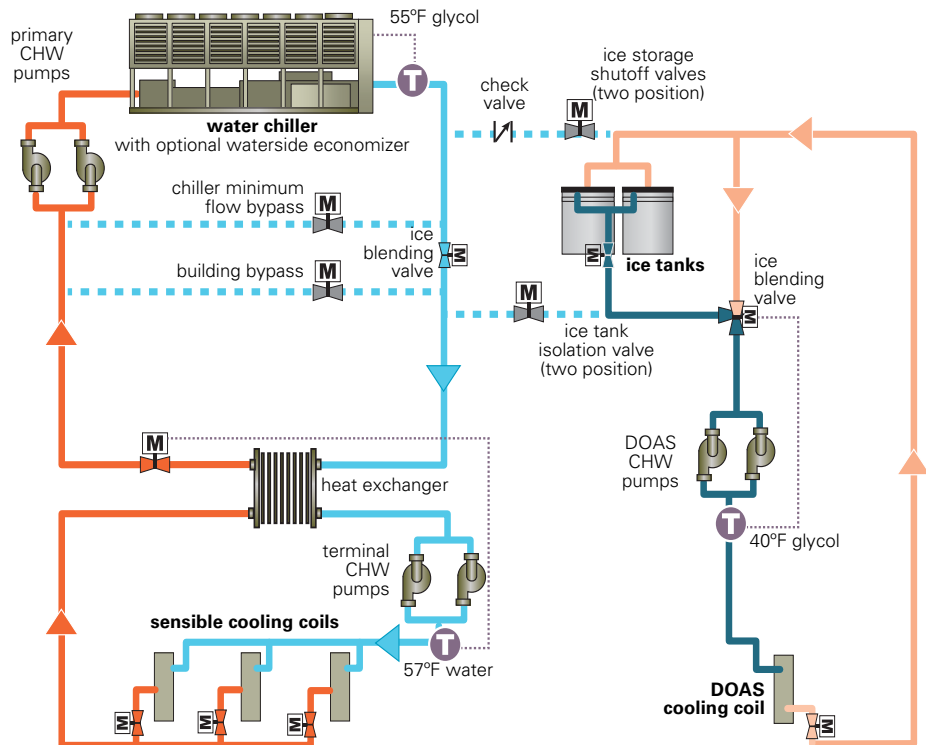

© Trane a business of Ingersoll Rand. Patent pending.

fluid—55°F in this example—due to the "approach" of the intermediate heat exchanger.)

When the building is unoccupied at night, the water chiller switches to ice-making mode and lowers its leaving-water setpoint to freeze the water inside the ice tanks for the next day (Figure 11). This configuration provides the added benefit of shifting the "cold-water" chiller load to the nighttime hours, when the cost of electricity (including demand charges) is likely to be lower.

Adding a diverting valve and connecting pipe (Figure 12), along with using two cooling coils in series in the dedicated OA unit, enhances the flexibility of this plant arrangement and allows it to:

- Operate the chiller only during the daytime, if ice is not available for some reason
- Use the melting ice to satisfy some of the terminal unit cooling loads also, on days when not all the ice is needed for DOAS dehumidification
- Provide zone sensible cooling at night, while concurrently making ice
- Provide zone dehumidification at night, while concurrently making ice

Finally, if waterside economizing is desired, it is typically provided using either air-to-water heat exchangers integrated into the air-cooled chiller (typically mounted on the outside of the air-cooled condenser coils) or a separate "dry cooler" piped into the system.

Plant with Multiple Chillers

Many chiller plants are designed to include more than one chiller, to improve plant efficiency and/or to provide redundancy if one of the chillers were to fail or require service. (While the diagrams in this section show water-cooled chillers, air-cooled chillers could be used instead.)

Figure 11. Single-chiller, dual-temperature plant with ice storage (nighttime)

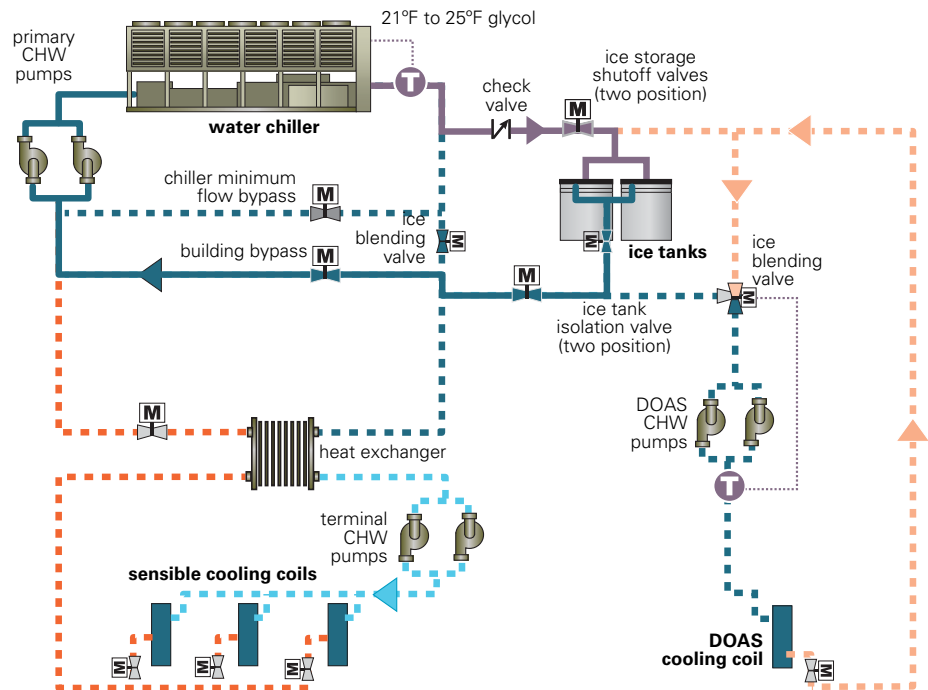

© Trane a business of Ingersoll Rand. Patent pending.

Figure 12. Single-chiller, dual-temperature plant with ice storage (enhanced)

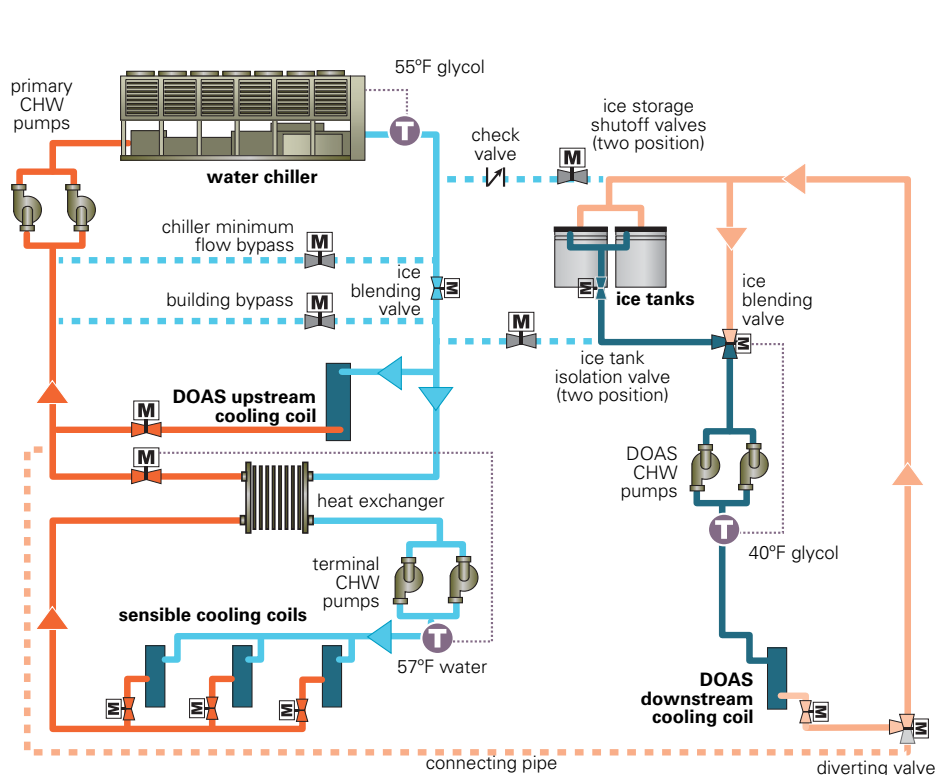

© Trane a business of Ingersoll Rand. Patent pending.

In this case, the most efficient configuration is likely to use dedicated chillers with interconnecting pipes and shutoff valves to provide redundancy (Figure 13).

In this configuration, the "warm-water" chiller #1 is selected and optimized to supply 57°F water to the sensible-cooling terminal units, while the "cold-water" chiller #2 is selected and optimized to supply 40°F water to the DOAS dehumidifying coils. Chiller #3 is then selected so that it is capable of providing either 57°F or 40°F water, in the event that one of the other two chillers is in need of service. (An operator could choose to rotate operation of chillers to "give some runtime" to the backup chiller #3.)

If waterside economizing is desired, it is typically provided using either a separate plate-and-frame exchanger connected to the condenser-water loop (as shown in Figure 13), or by using a "free-cooling" centrifugal chiller (i.e., a thermosiphon) as the "warm-water" chiller #1.

Figure 13. Multiple-chiller, dual-temperature plant

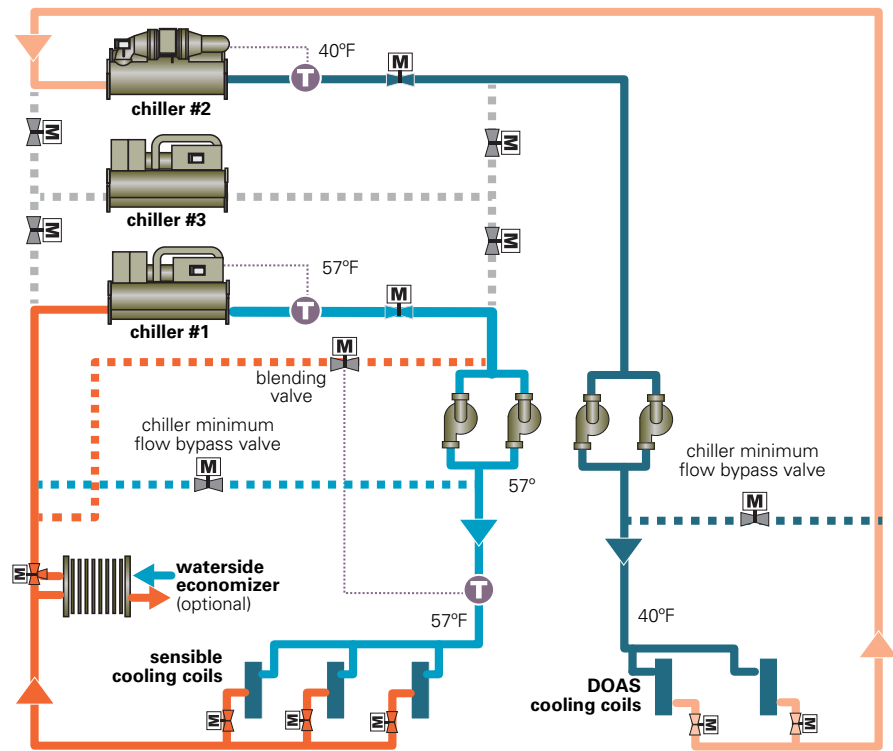

Summary

As buildings are designed for lower energy use, the resulting reduction in sensible cooling loads presents an economically feasible opportunity for systems that use zone-level, sensible-only cooling equipment. Reasons for using a dedicated OA system with sensible-cooling terminal units include:

Efficiency.

- Variable-speed fan control in both the terminal units and dedicated OA unit
- Zone sensible cooling is provided with warmer chilled water (typically 56°F to 58°F)
- Each terminal unit is equipped with a flow-measuring damper, making it easy to implement demand-controlled ventilation.

Comfort.

- Each terminal unit is controlled by a zone temperature sensor, and contains a cooling coil and (optionally) either a hot-water coil or electric heater, allowing each zone to receive either cooling or heating as needed.
- Dehumidification is provided by the centralized, dedicated OA unit; and, when equipped with a humidity sensor, the terminal unit actively adjusts dehumidified airflow from the dedicated OA unit to limit space humidity.

Flexibility and space required.

- The dedicated OA unit and its associated ductwork are typically sized for only the minimum ventilation airflow required, in turn requiring less ceiling plenum height and allowing for more usable space inside the building.
- Re-configuring a zone often requires moving only the downstream flex duct and supply-air diffusers; the sensible-cooling terminal units and water piping may not need to be moved.

- The sensible-cooling terminal units can be equipped with either a hot-water coil or electric heater, if necessary. Electric heat offers a lower installed cost option, avoiding the need to install a hot-water boiler, piping, pumps, and valves.

Maintenance.

- No condensation occurs at the zone-level terminal units, meaning no drain pans to clean and no condensate drain traps and piping lines to install and maintain.
- Since the cooling coil in each terminal unit operates dry, no filter is required upstream.

By John Murphy, applications engineer, Trane. You can find this and previous issues of the Engineers Newsletter at trane.com/engineersnewsletter. To comment, e-mail us at ENL@trane.com.

Dedicated outdoor air system with sensible-cooling terminal units

Resources

Application literature www.trane.com/bookstore

CoolSense™ Integrated Outdoor Air System (APP-PRC004-EN) systems catalog

Dual Temperature Chiller Plants (ADM-APN055-EN) *Engineers Newsletter*

Dedicated Outdoor Air Systems (SYS-APG001-EN) application guide

Chilled-Water Sensible-Cooling Terminal Units (DOAS-PRC001-EN) catalog

Online videos www.trane.com/ContinuingEducation

Dedicated Outdoor-air Equipment . Dedicated outdoor-air systems have become increasingly popular. While previous discussions covered design and control considerations for dedicated OA systems, this course focus on the equipment used to condition the outdoor air. Discussion covers the various types and configurations of equipment used for dedicated OA conditioning, from packaged DX units to split DX systems to air handlers and water chillers.

Chilled-Water Terminal Systems. Trane applications engineers discuss system design and control strategies for various types of chilled-water terminal systems, including fan-coils, chilled beams, sensible-cooling terminal units and radiant cooling. Topics include: types of terminal equipment, variable-speed terminal fan operation, dedicated OA system design, chilled-water system design, and complying with ASHRAE® 90.1 requirements.

CoolSense™ Integrated Outdoor Air System training video. This HVAC system training program introduces viewers to a new Trane® EarthWise™ System that uses chilled-water, sensible-cooling terminal units integrated with a dedicated outdoor air system. Topics include system design concepts, terminal unit and system controls, condensation prevention, dedicated outdoor air configurations, along with various dual-temperature chiller plant configurations. The discussions summarizes the features and benefits of the system, including an energy modeling comparison between ASHRAE 90.1 baseline, active chilled-beam and high-performance VAV systems. Please contact your local Trane sales office for system details.

www.trane.com/CoolSense

www.Trane.com/bookstore

HVAC Educational Resources



On-demand continuing education credit for PE, LEED®.

60 to 90-minute, on-demand programs available free of charge. Check out the newest courses or view a complete list of courses at www.trane.com/continuingeducation.

Engineers Newsletters. Quarterly articles that cover timely topics related to the design, application and operation of commercial HVAC systems. Subscribe at trane.com/EN.

Air conditioning clinics. A series of educational presentations that teach HVAC fundamentals, equipment and systems. The series includes full-color student workbooks, which can be purchased individually. Approved by the American Institute of Architects for 1.5 (Health, Safety and Welfare) learning units. Contact your **local Trane office** to sign up for training in your area.

Engineers Newsletter Live. A series of 60 to 90-minute programs that provide technical and educational information on specific aspects of HVAC design and control. Topics range from water- and airside system strategies to ASHRAE® standards and industry codes. Contact your local Trane office for a schedule of upcoming events or order DVDs of past programs by visiting www.trane.com/ENL.

Application manuals. Comprehensive reference guides that can increase your working knowledge of commercial HVAC systems. Topics range from component combinations and innovative design concepts to system control strategies, industry issues, and fundamentals. View a complete list of manuals available to order at www.trane.com/bookstore.

New HVAC Design and Selection tools...

Mobile TOPSS™ new and improved user experience.

Check out the enhanced Trane Performance Climate Changer™ portfolio selection process in the latest version. It's...

- Fast - many selections can be completed in under 30 seconds - you need to see it to believe it
- Accurate - BIM objects simplify design integration and dimensional drawings, wiring diagrams, and configuration recommendations streamline selections
- Easy - simple and clear unit graphics help configure a unit to your exact needs

Visit www.trane.com/TOPSS to select a Trane Performance ClimateChanger Air Handling Unit today!



Quickly estimate chiller energy use and cost with myPLV™.

This free, manufacturer-agnostic tool is designed to help HVAC designers quickly and accurately estimate chiller energy usage based on their project specific operating conditions. The tool uses industry standard building model data in combination with the user-specific information where users select their location and building type; building peak load; number and size of the chillers in the plant; and chiller condenser control strategy.

The latest version of myPLV includes a new water-cooled chiller plant energy simulation tool to better gauge the annualized effects of various design condenser water flow conditions as well as the overall energy effects based on component efficiency selection. Download a free copy of the tool and resources to get you started at trane.com/myPLV.

Online software tutorials to help you get the most from your Trane energy modeling software.

These short instructional tutorials cover specific topics to help you work smarter. Topics range from tips for resolving unmet load hours to modeling waterside economizers in TRACE™ 700.

Check out the **NEW C.D.S. Support site** and view the latest tutorials, visit trane.com/CDSHelp (select the eLearning tab)

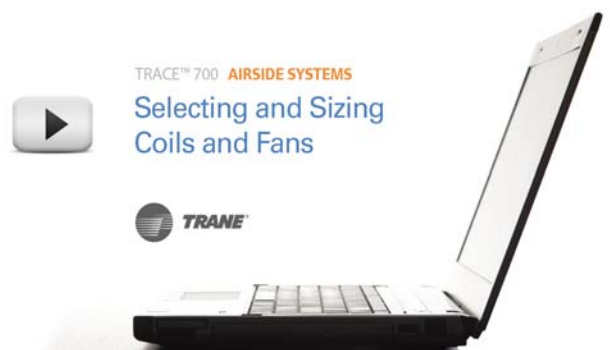
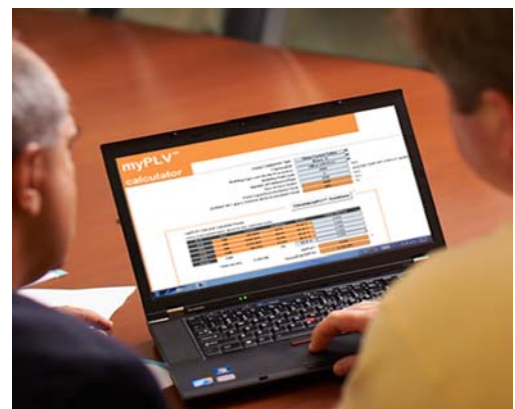

Join your local Trane office
Mark your calendar!

HVAC Myths and Realities addresses various “myths,” claims, and misunderstandings in the HVAC & R market place then follows with technically correct details, examples and situations to help design teams evaluate the likelihood of actually realizing claimed effectiveness, performance and savings. (May)

High-Performance Air Systems examines the properties of high-performance air systems and provides guidance on their design. Topics include right-sizing and proper component selection, duct design guidelines, system control strategies, selection for part-load efficiency and much more. (September)

Demand Response in Commercial Buildings discusses the relevant improvements that load shifting and demand response can provide, with examples of the types of utility and funding programs that are available. (October)

Contact your local Trane office for event details.

For more programs or to order past programs available on DVD visit **Trane.com/ENL**



*Trane,
A business of Ingersoll Rand*

For more information, contact your local Trane office or e-mail us at comfort@trane.com

Trane, the Circle Logo, TOPSS, Performance Climate Changer, myPLV, and TRACE are trademarks of Trane in the United States and other countries. ASHRAE is a registered trademark of the American Society of Heating, Refrigerating, and Air-Conditioning Engineers, Inc.. LEED is a registered trademark of U.S. Green Building Council. All trademarks referenced in this document are the trademarks of their respective owners.

This newsletter is for informational purposes only and does not constitute legal advice. Trane believes the facts and suggestions presented here to be accurate. However, final design and application decisions are your responsibility. Trane disclaims any responsibility for actions taken on the material presented.