



TRANE[®]

TRANE
TECHNOLOGIES

REFERENCE DESIGN #501

HIGH-EFFICIENCY COOLING FOR THE 1 GW AI FACTORY

CenTraVac[®] Simplex Reference Design

A scalable reference design that cuts energy,
water use and cost.





INTRODUCTION

Artificial intelligence is driving massive growth in data center demand — and advanced cooling is critical to keep innovation running. Trane leads the way with proven thermal management solutions for AI factories and data centers of all sizes.

This reference design provides:

- ✓ A 1 GW cooling blueprint for AI factory applications
- ✓ Integrated air- and liquid-cooling configurations for NVIDIA racks
- ✓ Guidance on CDUs, fan coil walls, chillers, dry coolers, pumps and facility piping
- ✓ A foundation for mechanical design that complements electrical and controls systems





DESIGN OVERVIEW

Temperature and Flow Rates

This table summarizes temperature and flow rate requirements for the water-cooled chillers in this reference design. These values represent an AI factory installed in Albuquerque, NM and can be adjusted for specific applications.

Technical Loop Supply Temperature: 30°C (86°F)

Technical Loop Return Temperature: 40°C (104°F)

Fan Coil Wall Supply Air Temperature: 27°C (80.6°F)

	Medium Temperature (Airside)	High Temperature (Liquid Direct to Chip)
Total Block Load	13.74MW (3,906T)	102.4MW (29,120T)
Load Requirement/Chiller	6.87MW (1,953T)	10.24MW (2,912T)
Evaporator Flow Rate/Chiller	9,978 LPM (2,635.9 GPM)	14,878 LPM (3,930.4 GPM)
Facility Loop Temperature (High)	32°C (89.6°F)	36°C (96.8°F)
Facility Loop Temperature (Low)	22°C (71.6°F)	26°C (78.8°F)
Facility Loop Fluid	Water*	Water*
Condenser Flow Rate/Chiller	14,771 LPM (3,902.5 GPM)	19,992 LPM (5,821.3 GPM)
Heat Rejection Loop Temperature (High)	53.3°C (128°F)	53.3°C (128°F)
Heat Rejection Loop Temperature (Low)	45.6°C (114°F)	45.6°C (114°F)
Heat Rejection Loop Fluid	Water*	Water*
Max Ambient (Albuquerque, NM)	40°C (104°F)	
Elevation (Albuquerque, NM)	1,619m (5,312')	

*Our recommendation is to utilize freeze protection.

DESIGN OVERVIEW

Reference Diagram

✓ 1 GW mechanical cooling blueprint for AI factories

✓ Integrates air- and liquid-cooling systems

✓ Modular structure for scalability and serviceability

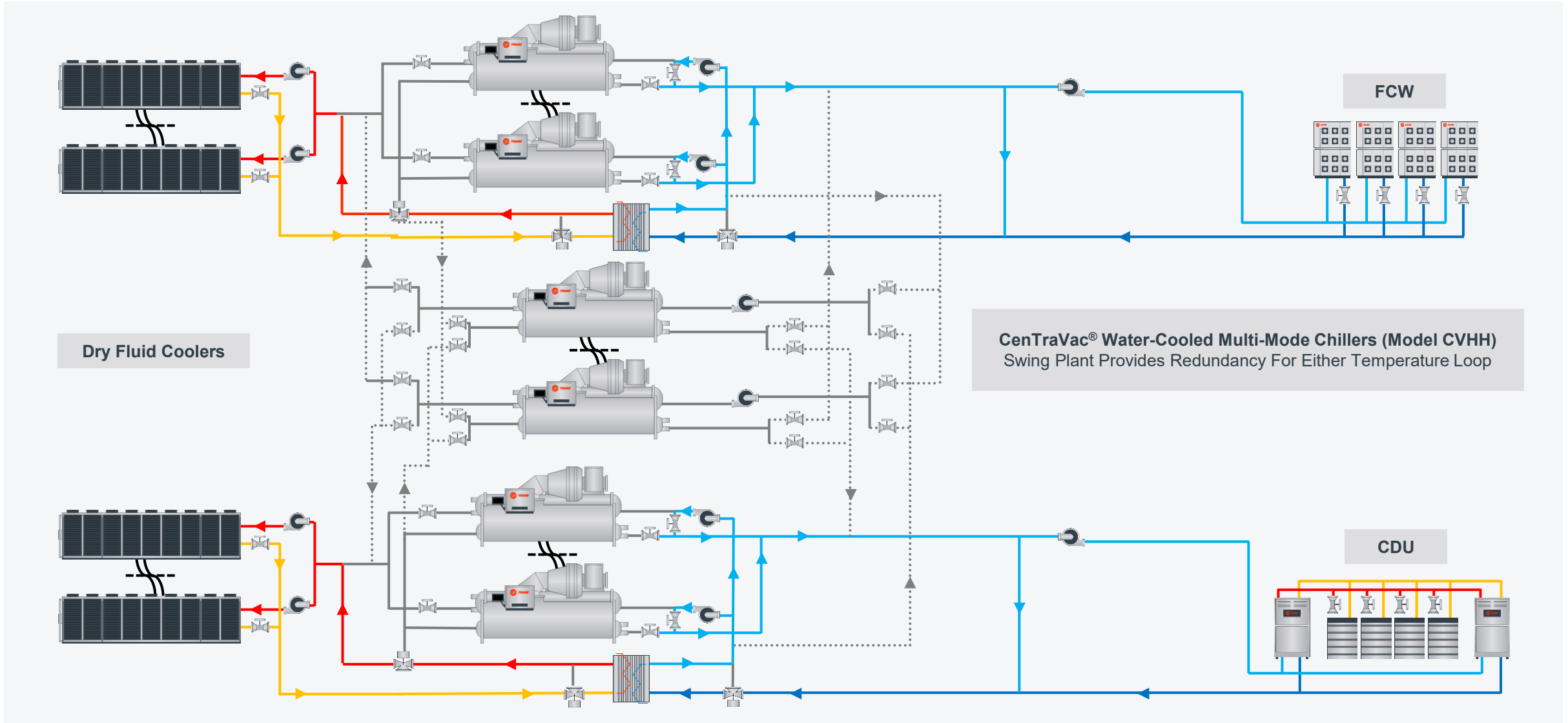

→ DESIGN OVERVIEW

Customer Outcomes



Reduce power use

- High-efficiency Trane water-cooled chillers minimize plant energy consumption
- Lower cooling power frees additional electrical capacity for compute operations, increasing token production and overall site profitability
- Advanced controls optimize chiller lift and pump energy to maintain best-in-class PUE



Future-ready design

- Built to adapt as chip densities increase and cooling demands evolve
- Supports flexible ratios of liquid and air cooling
- Dual-mode chillers in the swing plant enable smooth rebalancing between cooling loops without adding new equipment



Balanced total cost of ownership (TCO), redundancy and resiliency

- Swing chillers can be assigned to either high- or low-temperature loops, reducing the total number of chillers required
- Fewer units mean lower capital cost while maintaining redundancy and uptime
- High-efficiency water-cooled design with dry coolers keeps both energy and water costs low — improving ROI and sustainability metrics

→ SYSTEM BENEFITS

Water-cooled systems offer significant performance and sustainability advantages over air-cooled alternatives, delivering higher efficiency, lower water use and reduced environmental impact for large-scale AI data centers.

- Fewer chillers due to larger capacity per unit
- Improved efficiency — better Power Usage Effectiveness (PUE)
- Dry coolers eliminate water use —
Water Usage Effectiveness (WUE) = 0
- R-1233zd refrigerant (GWP 1) cuts carbon impact
- Dedicated temperature loops maximize free-cooling hours



→ KEY SYSTEM COMPONENTS

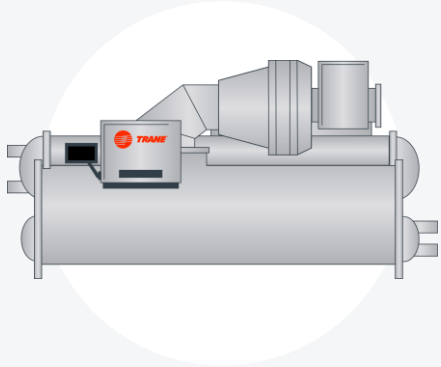

Water-Cooled Chillers

Trane CenTraVac[®] chillers are engineered for data centers, operating efficiently at higher water temperatures to deliver reliable cooling and improved overall plant performance.

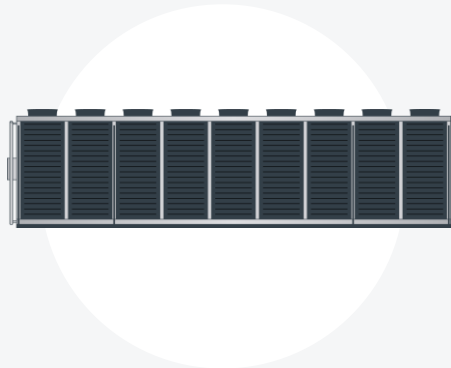

Dry Coolers

Dry coolers reject heat directly to ambient air using dry-bulb temperature, eliminating water use and achieving a WUE of zero. Trane works with leading manufacturers to assure each system is optimized for site conditions and climate.



Fan Coil Walls

Trane Fan Coil Walls provide higher capacity, efficient air cooling in the data hall, using medium chilled-water temperatures to deliver added capacity where air cooling is needed most.



Coolant Distribution Units (CDUs)

Trane CDUs support the liquid-cooled portion of the data hall, separating facility and technical loops with a liquid-to-liquid heat exchanger for efficient, high-temperature cooling compatible with AI servers.

→ KEY SYSTEM COMPONENTS

CenTraVac® Water-Cooled Chillers Model CVHH

Design Characteristic	Requirements
Capacity Range	Up to 3,000 tons (11 MW)
Leaving Condenser Temp	Up to 68.3°C (155°F)
Facility Water Temperature Range	Up to 37.8°C (100°F)
Compressor	Centrifugal Compressor
Heat Rejection Options	Dry Cooler/High Lift Application 6-pipe Heat Recovery Options
Refrigerant	Low GWP: R-1233zd
Restart After Power Loss	43-76 Seconds Depending Upon Starter/Drive
Power Feed Requirement	2300V to 12 kV Starter and Drive Options



→ KEY SYSTEM COMPONENTS

Dry Cooler

Design Characteristic	Requirements
Capacity Range	1,500 tons (5 MW+)
Max Ambient Dry Bulb	62.8+°C (145+°F)
Fans	Variable Speed VFD or ECM Driven Fans
Power Feed Requirement	380-480, 3 ph, 50/60 Hz

Dry Cooler capacity and performance is dependent on local ambient extreme conditions.

* This is based on Albuquerque, New Mexico design conditions



There are many dry coolers solutions in the market. This design is based on a general dry cooler configuration. Specifications may change depending on the dry cooler used in application.

→ KEY SYSTEM COMPONENTS

Fan Coil Wall

Design Characteristic	Requirements
Capacity Range	Up to 670 KW
Airflow Range	110K CFM+
Entering Air Temp	Up to 40°C (104°F)
Fan Type	ECM Direct Drive Fans
Additional Feature Options	Controls Teaming Application Pressure Independent Control Valve Automatic Transfer Switch
Filtration	2" or 4" Filters (MERV 8 or 11)
Harmonic Filtration	5% or Less of Total Demand Distortion
Power Draw	< 6% of Capacity Being Cooled in KW
Power Feed Requirement	415-480, 3 ph, 50/60 Hz



→ KEY SYSTEM COMPONENTS

Coolant Distribution Unit (CDU)

Design Characteristic	Requirements
Capacity Range	Up to 10 MW at 4°C (7.2°F) Approach
Effectiveness	>90% at 4°C (7.2°F) Approach
Minimum Pressure Head	40 PSID + dp Across CDU
Design Secondary (PG 25) Supply Temp	Up to 45°C (113°F)
Design Facility Water Temperature	Up to 41°C (105.8°F)
Max Ambient Temperature Operation	50°C (122°F)
Additional Feature Options	Scalable Solution Controls Teaming Application Pressure Independent Control Valve 316 Stainless Steel Plate Heat Exchanger Triple-Redundant Sensors in the Header
Secondary Side Filtration	25-Micron Filtration
Power Draw	< 1% of Capacity Being Cooled in KW
Power Feed Requirement	380-480, 3 ph, 50/60 Hz



→ KEY SYSTEM COMPONENTS

Computer Room Air Handler (CRAH)

Design Characteristic	Requirements
Capacity Range	50kW to 360kW to support varied density zones
Airflow Range	5,000 - 50,000k CFM
Fan Type	ECM Direct Drive Fans
Entering Air Temp	Up to 43°C (110°F)
Additional Feature Options	Automatic Transfer Switch (ATS) Controller Capacitor Backup Condensate Pump Motorized return air damper
Filtration	2" (Merv 8 or 11) or 4" (Merv 8) Filters
Harmonic Filtration	5% or Less of Total Demand Distortion
Deployment Configuration	Downflow horizontal discharge for electrical room cooling Flexible for downflow white space use Optional upflow configuration
Power Feed Requirement	415-480, 3-phase, 60 Hz



→ BEST PRACTICES

Decoupled Loops

Separating the production (chiller) and distribution loops allows each to operate at its optimal temperature difference (ΔT), improving efficiency and control while reducing pump energy. The decoupled design also simplifies system staging and enhances overall plant stability.

- Production and distribution loops operate independently to optimize flow and ΔT
- Pump energy consumption is reduced under varying load conditions
- Flow through the decoupler indicates plant balance and triggers chiller staging
- The design provides smoother operation and faster response to load changes

Typical Decoupled Plant

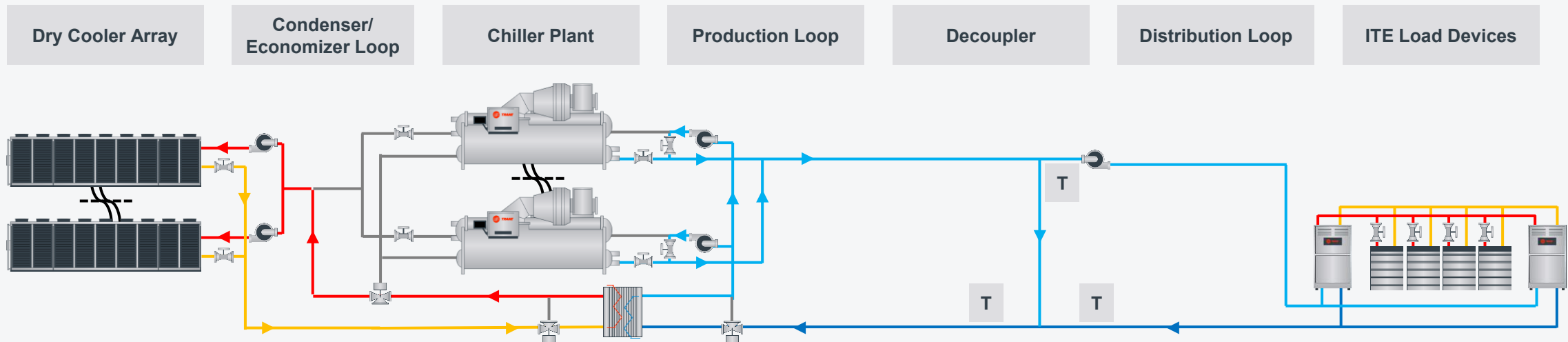

→ BEST PRACTICES

Redundancy

Air- vs. water-cooled chillers

Redundancy needs vary by system type. Air-cooled chillers are dual circuit, while water-cooled (CVHH) units have a single circuit. Air-cooled units contain more components and are more sensitive to airflow loss (reduced airflow can cause high-pressure shutdowns), while dry coolers and water-cooled chillers can continue operating at reduced capacity.

Single vs. dual compressor

Trane CVHH chillers use a single compressor, while CDHH units feature two for added reliability. Dual-compressor chillers offer built-in redundancy, maintaining operation during maintenance or partial failures.

Swing chiller plant

In most AI data centers, liquid cooling carries the majority load and air cooling handles the minority. Because air coils require colder supply water, the plant must accommodate both temperature needs efficiently.

- **Single-temperature plant**

A single-temperature system supplies colder water for air cooling and mixes part of it to a higher temperature for liquid cooling. While simple, this adds unnecessary lift to the liquid loop and increases energy use.

- **Dual-temperature plant**

A dual-temperature system uses dedicated high- and low-temperature loops, eliminating the efficiency penalty of added lift. The high-temperature loop supports more hours of free cooling, while both loops maintain redundancy through shared or swing chillers.

→ BEST PRACTICES

Redundancy

Dual-temperature chiller plant, dedicated low and high temperature chillers

A dual-temperature chiller plant with dedicated low- and high-temperature chillers uses separate equipment for each loop, providing full redundancy within both systems. This configuration maintains independent operation and ensures uninterrupted cooling even if one loop or chiller set is offline for maintenance or repair.

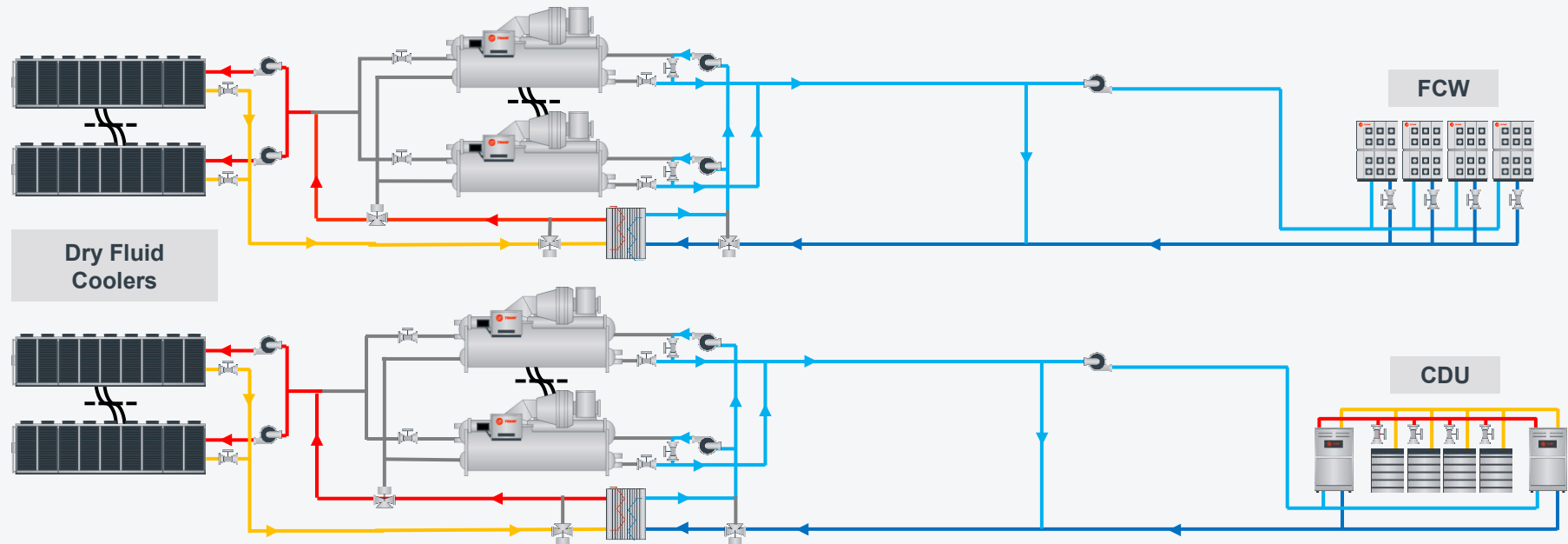

Mechanical Cooling

Free Cooling

→ BEST PRACTICES

Redundancy

Dual-temperature plant with swing chillers

A dual-temperature chiller plant with swing chillers allows redundant units to be flexibly assigned to either the high- or low-temperature loop, reducing the total number of chillers needed when full dual-loop redundancy isn't required.

The swing chillers are selected for multiple modes of operation to ensure they can serve either loop.

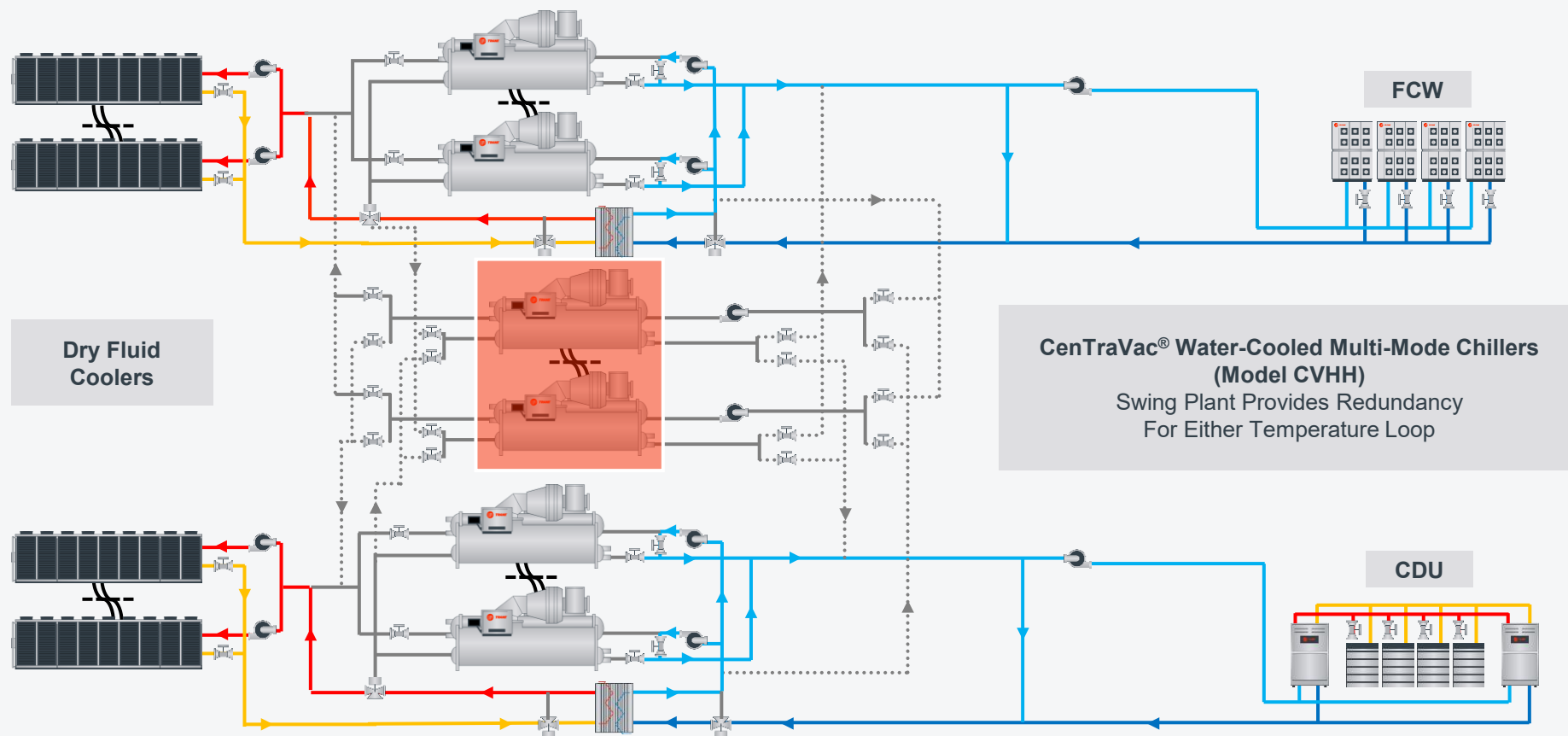

BEST PRACTICES

Block Sizing

Designing a single chiller plant for a 1 GW data center isn't practical due to the massive pipe, valve, and pump sizes required. A better solution is to divide the load into 102.4 MW partitions, typically using 48-inch piping based on system design.

- Each partition is served by 10 - 9.6 MW CDU pods and 1 - 6.4 MW CDU pod
- Each CDU has N+1 Redundancy
- Each totals 102.4 MW and includes 512 (200-kW) racks.
- 9.6 MW Deployment : 4 rows, 12 *200-kW racks per row
- 6.4 MW Deployment: 4 rows, 8 *200-kW racks per row
- Remaining site power reserved for airside cooling loop, additional IT loads and other site needs

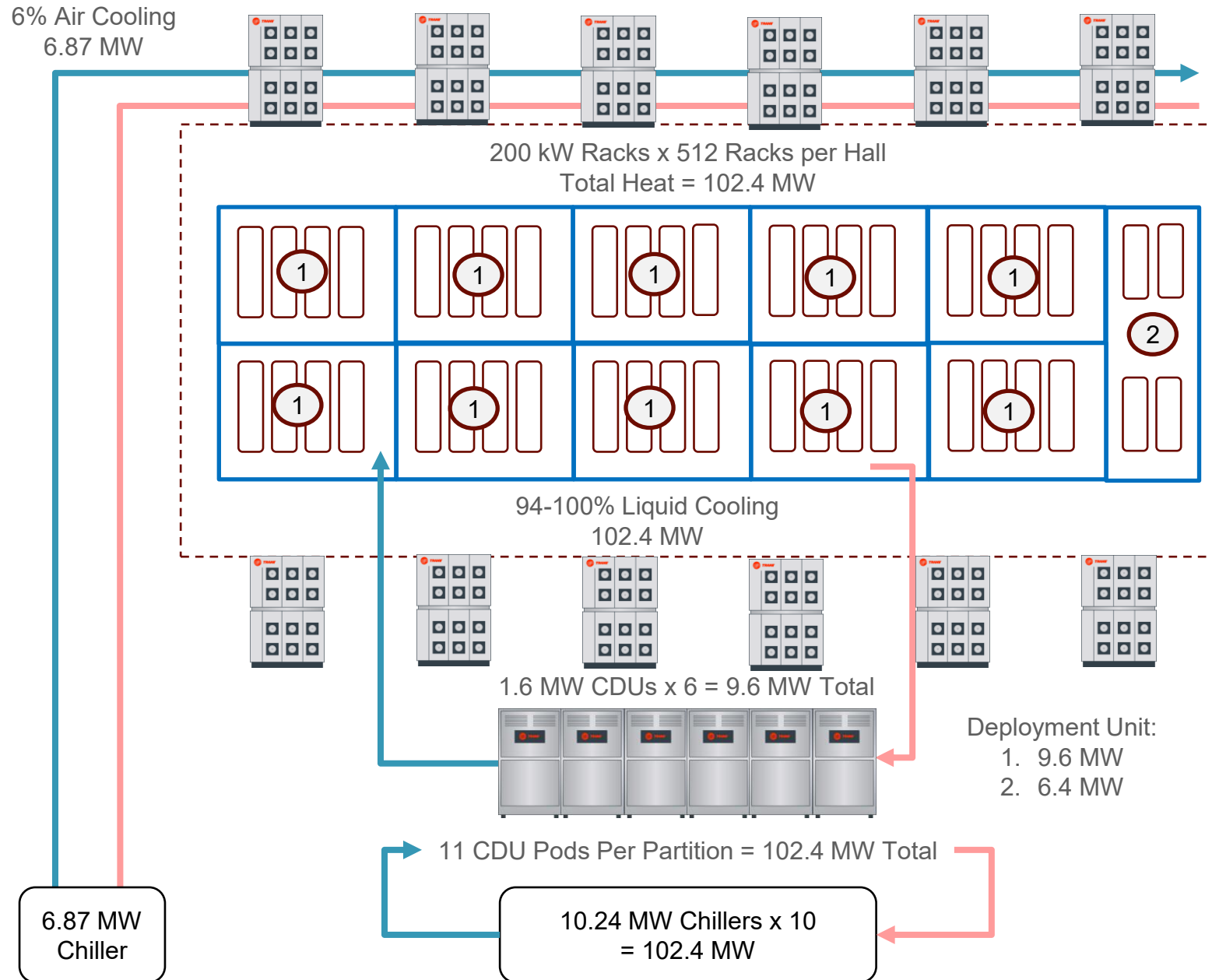

→ BEST PRACTICES

Free Cooling

Cooling loads are typically designed for the maximum expected demand, or “design point.” In practice, both the cooling load and outdoor ambient temperature fluctuate, creating opportunities for “free cooling” when conditions allow. This reference design uses dry coolers and a plate-and-frame heat exchanger to provide free cooling under favorable ambient temperatures.

Free-cooling capacity depends on the difference between the fluid temperature and outdoor dry-bulb temperature. For this reference design, operation can be grouped into two modes.

Mode 1: Free Cooling

Outdoor temperature is low enough to provide full cooling without mechanical assistance.

Mode 2: Hybrid Cooling

Outdoor temperature is lower than return temperature; exceeds temperature to provide full cooling capacity

Mode 3: Mechanical Cooling

Outdoor temperature exceeds fluid return temperature — free cooling is bypassed.

→ **BEST PRACTICES**

Freeze Protection

Outdoor equipment such as dry coolers and exposed piping is at risk of freezing when ambient temperatures drop below the fluid's freeze point. Protection can be achieved by selecting a suitable fluid or by adding heat to maintain temperature above freezing.

- Select a fluid with a freeze point below expected operating conditions
- Add heat to keep local temperatures above the fluid's freeze point

Glycol solutions (propylene or ethylene) have a freeze point, where crystals begin to form, and a burst point, where expansion can cause damage. Proper concentration ensures the fluid remains pumpable and prevents freezing under site conditions.

If water is used, heat must be added to maintain temperature above freezing — especially in heat-rejection devices like dry coolers. The required heat depends on ambient conditions, water volume, and insulation quality.

If glycol is undesirable in the full loop, install isolation heat exchangers and local pumps to confine glycol to small closed loops while maintaining protection for any connected water lines.

→ BEST PRACTICES

Thermal Energy Storage

Thermal storage can be integrated into the chiller plant in several ways, with tank location determined by system needs.

- **Tank in the decoupler line.** Locating the tank in the decoupler line includes all the benefits noted above. This location also allows it to act as a thermal battery — charging when production exceeds demand and discharging when demand is higher. This cycle can repeat throughout the day and be optimized by system controls.
- **Tank on return side.** When placed on the return side, the tank buffers large temperature swings in water returning to the chillers during rapid load changes. Maintaining stable return temperature helps chillers deliver consistent leaving-water temperature.

Thermal storage tank in the decoupler pipe

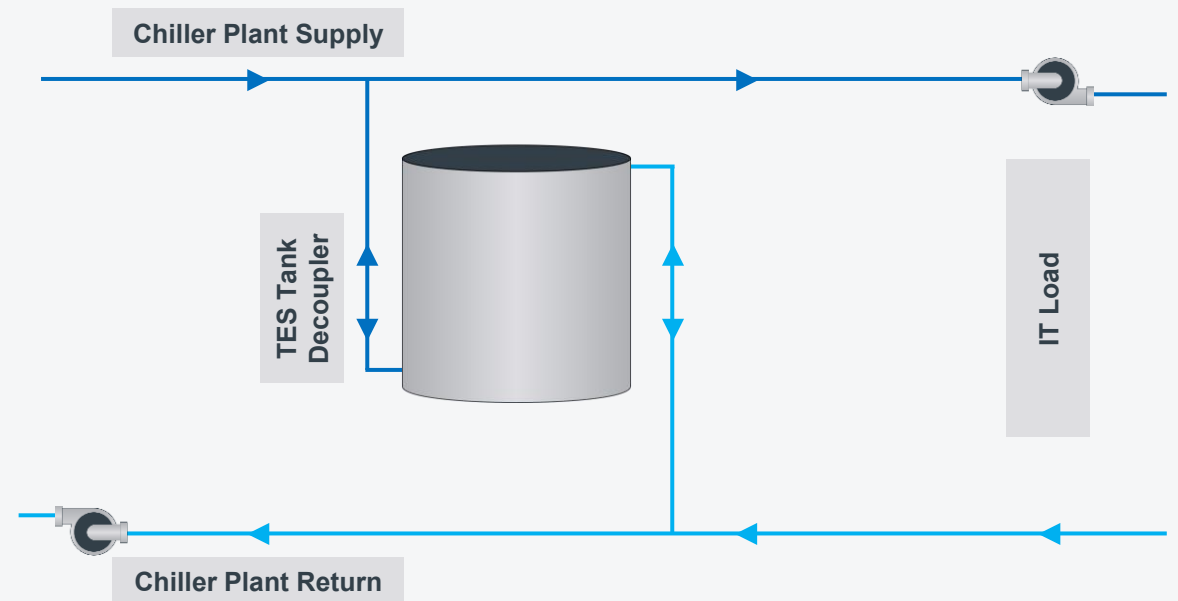

→ **SYSTEM CONTROLS**

Effective controls are critical to chiller plant performance and reliability. Trane's data center-specific control platform promotes efficiency, uptime and responsiveness by integrating all major components — chillers, dry coolers, pumps, valves, CDUs and fan coil walls — into one coordinated system.



SYSTEM CONTROLS

Reference Diagram

System Control

Tracer® is the single, powerful thermal management control system that simplifies operations by managing chiller rotation, staging and sequencing with built-in tools that ensure reliable performance and unlock data-driven capabilities.

AI Enhancements

Take your system optimization further with our AI-driven efficiency powerhouse. **Trane Autonomous Control** combines decades of building performance expertise with real-time data to drive continuous improvements in your thermal management system — finding every watt that can be optimized.

Trane Thermal Management System

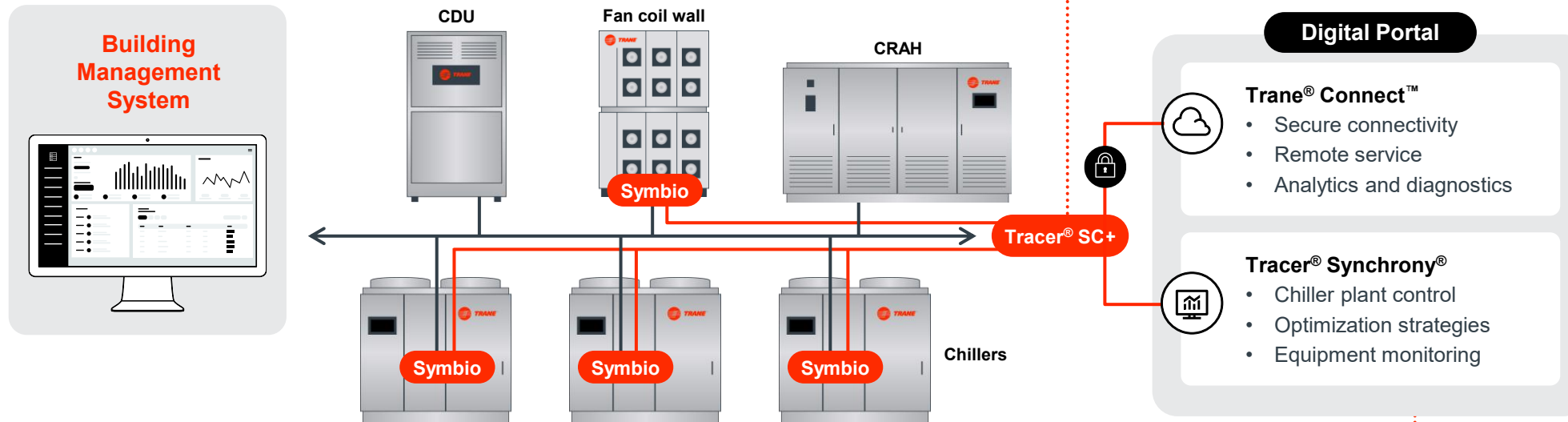

Insights + Optimization

When power access is in question, your thermal management system must run at peak efficiency — because every kilowatt saved on cooling means more racks online. **Trane Intelligent Services** pulls data from your entire system to deliver actionable energy-saving strategies.

Equipment Connectivity

Symbio® equipment controls capture and translate a broad range of equipment-based points into the Tracer SC+, providing the basis for data-driven service and optimization strategies.

Predictive Maintenance

With your permission, we can securely connect to your equipment controls or Tracer SC+ to enable **Connected Mechanical Service**. By monitoring trend data and performance metrics, we can help identify emerging issues sooner, so your team or our service technicians can take the right action before failure or downtime occurs. When you need us on-site to address issues, **Trane Service Agreements** and **local technicians** are there when you need us.



TRANE SERVICE

As data centers expand in size and complexity, the need for dependable, efficient cooling grows with them. Trane's thermal management services are designed to meet these evolving demands — providing scalable, responsive support that adapts to changing loads, tighter schedules and zero-tolerance uptime requirements.

- Embedded expertise ensures reliable operation from design through expansion and refresh
- Proactive planning helps reduce risk and downtime
- Connected insights help optimize capacity and efficiency across the lifecycle



→ TRANE RENTAL SERVICES

Need unrivaled temporary thermal management and power solutions for your data center? Trust Trane Rental Services for:

- Level 2, 3, and 4 **commissioning services**, including line flushes and load bank testing
- **Expansion and retrofits** for new chip designs
- Planned **maintenance, emergency response, and redundancy** to protect SLAs
- Overcoming **new equipment lead times** to speed up new facility launches

As one of North America's largest OEM HVAC rental companies, Trane Rental Services leads the market. Our highly trained staff, rapid emergency response, and unmatched expertise are supported by 150 locations, 230 parts centers, and 2,600 technicians. Choose Trane Rental Services for reliable, expert solutions.



→ DESIGN RESOURCES

Trane provides a complete suite of resources to support the design of high-performance thermal management systems for data centers.

- All mechanical components are selected for site-specific conditions, with detailed submittal packages available
- System control sequences and operating modes can be customized for any chiller plant configuration
- TRACE™ modeling tools evaluate annual energy performance and efficiency
- Application guides and Trane experts are available to assist with design, optimization and implementation

Reach out to Trane today for more information.





HELPFUL LINKS

Trane BIM and Selection Tools →

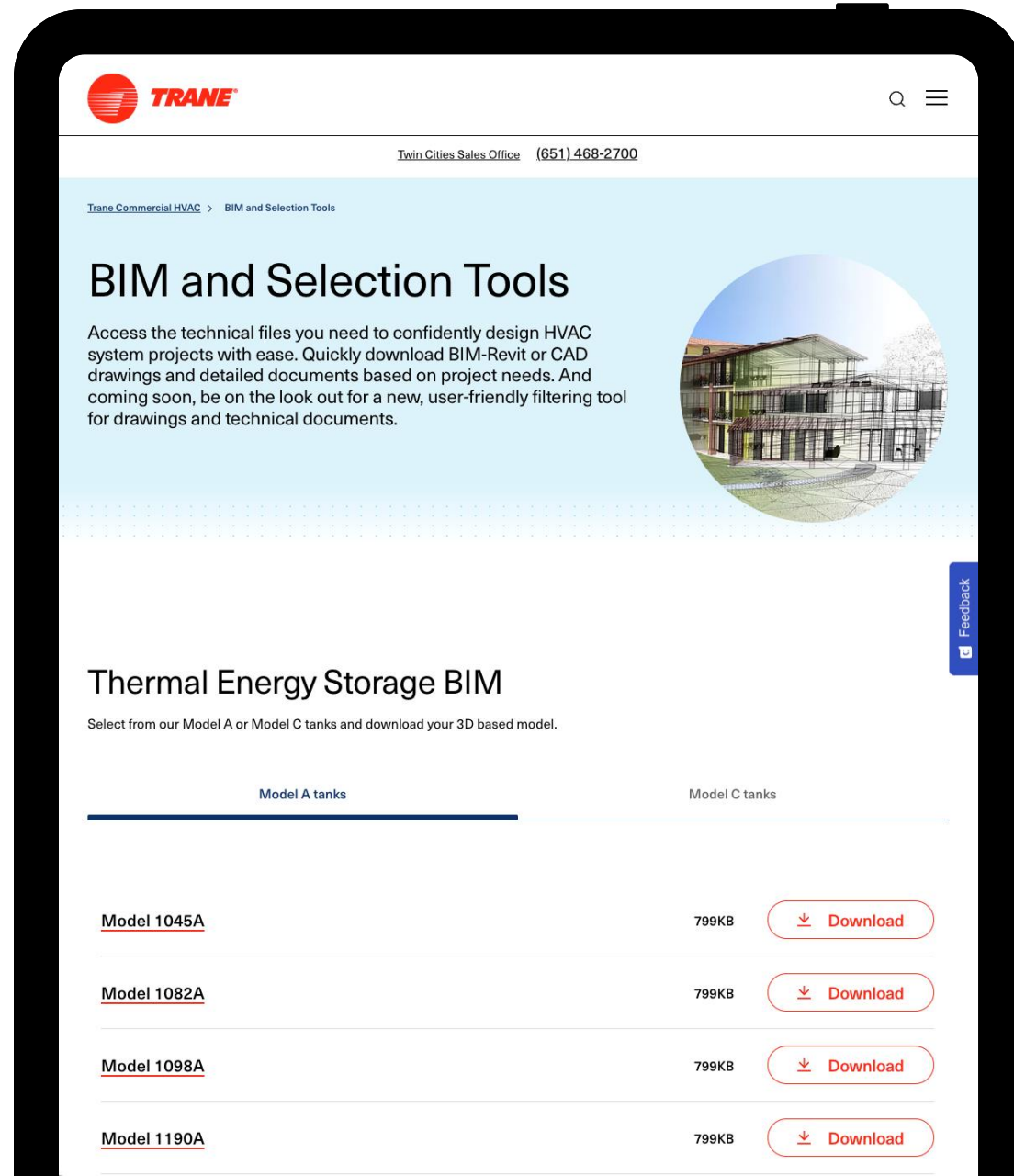

[Trane.com/DataCenters](https://www.trane.com/DataCenters)



TRANE[®]

TRANE
TECHNOLOGIES

Trane – by Trane Technologies (NYSE: TT), a global climate innovator – creates comfortable, energy efficient indoor environments through a broad portfolio of heating, ventilating and air conditioning systems and controls, services, parts and supply. For more information, please visit [trane.com](https://www.trane.com) or [tranetechnologies.com](https://www.tranetechnologies.com).

All trademarks referenced in this document are the trademarks of their respective owners. © 2025 Trane. All Rights Reserved.

DC-PRR001D-EN
03/13/2026