



# Installation Operation Maintenance

## Airfinity Rooftop units

Models

IC - Cooling only

IH - Heat pump

40 - 135 kW

R410A Refrigerant



RT-SVX056C-GB  
Original instructions



# Table of Contents

<b>General Information</b> .....	<b>4</b>
Foreword .....	4
Warnings and Cautions .....	4
Safety Recommendations .....	4
Reception.....	4
Loose Parts Inventory .....	4
Warranty .....	4
Refrigerant.....	4
Maintenance Contract .....	5
Storage .....	5
Training.....	5
<b>Unit Model Number Description</b> .....	<b>6</b>
<b>IC - IH General Data</b> .....	<b>8</b>
<b>Unit Operating Principle</b> .....	<b>17</b>
<b>Installation</b> .....	<b>18</b>
Reception of Units .....	18
Roof Curb Installation.....	18
Installing the Unit .....	19
Unit overall view.....	20
Dimensions/Weights/Clearances .....	21
Connection of Duct Network.....	21
Condensate Drain Piping .....	21
Filter Installation .....	22
Supply plug fan airflow adjustment.....	22
Supply fan Airflow measurement option .....	23
Gas Pipework Installation .....	23
Smoke outlet features .....	24
General Electrical Recommendations.....	24
Installer-Supplied Components .....	24
Electrical Connections .....	25
<b>Operating Map</b> .....	<b>26</b>
Cooling mode.....	26
Heating mode.....	26
ERC Cooling mode.....	27
ERC Heating mode.....	27

## Table of Contents

<b>Options</b> .....	<b>28</b>
Fresh air hood and grill installation .....	28
Building Pressurization Control .....	28
Hot Water Coil (HWC) .....	30
Electric Heater .....	30
Heat Recovery Module .....	31
Burner module .....	35
Energy Recovery Circuit (ERC) .....	35
Assembly procedure of fan block .....	35
ERC fan module installation .....	36
<b>Controls</b> .....	<b>37</b>
CH536 + module extension .....	37
Control Hardware Modules .....	37
Service Terminal .....	37
CO <sub>2</sub> sensor .....	38
CO <sub>2</sub> sensor maintenance .....	38
Fire Thermostat .....	38
Clogged Filter Detector .....	38
Smoke Detector .....	38
Other accessories available .....	38
Alarm and Warnings .....	38
<b>Customer option module</b> .....	<b>39</b>
Customer option module .....	39
Operation with a conventional thermostat .....	39
Economizer control .....	40
<b>Operation</b> .....	<b>41</b>
Test Procedures .....	41
Gas Burner first start .....	42
ERC first start and control .....	42
<b>Maintenance</b> .....	<b>43</b>
End-user Routine Maintenance .....	43
Service Technician Maintenance .....	43
Troubleshooting Alarm and Warnings .....	43
<b>Recommended service routine frequencies</b> .....	<b>44</b>
<b>Maintenance routine</b> .....	<b>45</b>
<b>Additional services</b> .....	<b>46</b>

# General information

## Foreword

These instructions are given as a guide to good practice in the installation, start-up, operation, and maintenance by the user, of Trane Airfinity rooftop units. They do not contain full service procedures necessary for the continued successful operation of this equipment. The services of a qualified technician should be employed through the medium of a maintenance contract with a reputable service company. Read this manual thoroughly before unit start-up.

Units are assembled, pressure tested, dehydrated, charged and tested in accordance with factory standard before shipment.

## Warnings and Cautions

Warnings and Cautions appear at appropriate sections throughout this manual. Your personal safety and the proper operation of this machine require that you follow them carefully. The constructor assumes no liability for installations or servicing performed by unqualified personnel.

**WARNING!** Indicates a potentially hazardous situation which, if not avoided, could result in death or serious injury.

**CAUTION!** Indicates a potentially hazardous situation which, if not avoided, may result in minor or moderate injury. It may also be used to alert against unsafe practices or for equipment or property-damage-only accidents.

## Safety Recommendations

To avoid death, injury, equipment or property damage, the following recommendations should be observed during maintenance and service visits:

1. The maximum allowable pressures for system leak testing on low and high pressure side are given in the chapter "Installation". Insure to do not exceed test pressure by using appropriate device.
2. Disconnect the main power supply before any servicing on the unit.
3. Service work on the refrigeration system and the electrical system should be carried out only by qualified and experienced personnel.
4. To avoid any risk, it is recommended to place the unit on an area with restricted access.

## Reception

On arrival, inspect the unit before signing the delivery note. Specify any visible damage on the delivery note, and send a registered letter of protest to the last carrier of the goods within 7 days of delivery.

Notify the local TRANE sales office at the same time. The delivery note must be clearly signed and countersigned by the driver.

Any concealed damage shall be notified by a registered letter of protest to the last carrier of the goods within 7 days of delivery. Notify the local TRANE sales office at the same time.

Important notice: No shipping claims will be accepted by TRANE if the above mentioned procedure is not respected. For more information, refer to the general sales conditions of your local TRANE sales office.

Note: Unit inspection in France. Delay to send registered letter in case of visible and concealed damage is only 72 hours.

## Loose Parts Inventory

Check all the accessories and loose parts that are shipped with the unit against the shipping list. Included in these items will be the all kind of sensors, thermostat and electrical diagrams, service literature, which are placed inside the control panel and/or indoor section for shipment.

## Warranty

Warranty is based on the general terms and conditions of the manufacturer. The warranty is void if the equipment is repaired or modified without the written approval of the manufacturer, if the operating limits are exceeded or if the control system or the electrical wiring is modified. Damage due to misuse, lack of maintenance or failure to comply with the manufacturer's instructions or recommendations is not covered by the warranty obligation. If the user does not conform to the rules of this manual, it may entail cancellation of warranty and liabilities by the manufacturer.

## Refrigerant

Consult the addendum to Manuals for units with refrigerant, for conformity to the Pressure Equipment Directive (PED) 97/23/EC and Machinery Directive 2006/42/EC.

## General information

### Maintenance Contract

It is strongly recommended that you sign a maintenance contract with your local Service Agency. This contract provides regular maintenance of your installation by a specialist in our equipment. Regular maintenance ensures that any malfunction is detected and corrected in good time and minimizes the possibility that serious damage will occur. Finally, regular maintenance ensures the maximum operating life of your equipment. We would remind you that failure to respect these installation and maintenance instructions may result in immediate cancellation of the warranty.

### Storage

Take precautions to prevent condensate formation inside the unit's electrical components and motors when:

- a. The unit is stored before it is installed; or,
- b. The unit is set on the roof curb and temporary auxiliary heat is provided in the building.

Isolate all side panel service entrances and base panel openings (e.g., conduit holes, Supply Air and Return Air openings, and flue openings) to minimize ambient air from entering the unit until it is ready for start-up.

Do not use the unit's heater as temporary heat without completing the start-up procedures detailed under "Unit Start-Up".

- Units charged with refrigerant should not be stored where temperatures exceed 68°C.
- At least every three months, attach a gauge and manually check the pressure in the refrigerant circuit.
- If the refrigerant pressure is below 13 bar at 20°C (or 10 bar at 10°C), call a qualified service organization or Trane Sales Office.

The Trane Company will not assume responsibility for equipment damage resulting from accumulation of condensate on the unit electrical components.

### Training

To assist you in obtaining the best use of it and maintaining it in perfect operating condition over a long period of time, the manufacturer has at your disposal a refrigeration and air conditioning service school. The principal aim of this is to give operators and technicians a better knowledge of the equipment they are using, or that is under their charge. Emphasis is particularly given to the importance of periodic checks on the unit operating parameters as well as on preventive maintenance, which reduces the cost of owning the unit by avoiding serious and costly breakdown.



# Unit Model Number Description

## Digit 1 - Manufacturing location

E = Epinal France

## Digit 2 - Unit Model

I = Airfinity

## Digit 3 - Unit type

C = Cooling only

H = Reversible Heat pump

## Digit 4-5-6 Unit Nominal Capacity

038 = 38 kW Cooling only

039 = 39 kW

040 = 40 kW

048 = 48 kW Cooling only

049 = 49 kW

050 = 50 kW

058 = 58 kW Cooling only

059 = 59 kW

060 = 60 kW

063 = 63 kW Cooling only

064 = 64 kW

065 = 65 kW

074 = 74 kW

075 = 75 kW

084 = 84 kW

085 = 85 kW

100 = 100 kW

110 = 110 kW

130 = 130 kW

## Digit 7 - Efficiency level

S = Standard efficiency

## Digit 8 - Refrigerant

A = R410A Factory full refrigerant charge

B = R410A Factory refrigerant pre charge

## Digit 9 - Unit voltage

E = 400 V - 3 Ph - 50 Hz

## Digit 10 - Design Sequence

## Digit 11 - Design Sequence

## Digit 12 - Auxiliary Heat

X = Without

W = Hot water coil

E = Electric heater

G = Staged gas burner

M = Modulating burner

## Digit 13 - Gas type

X = Without

1 = Propane gas

2 = Natural gas (G20)

3 = Natural gas (G25)

## Digit 14 - Airflow configuration

D = Down Supply & Down Return

H = Horizontal Supply & Horizontal Return

I = Down Supply & Horizontal Return

J = Horizontal Supply & Down Return

## Digit 15 - Available static pressure

1 = Standard External Static Pressure

2 = High External Static Pressure

## Digit 16 - Operating map (cooling mode)

A = Standard ambient

L = Low ambient

## Digit 17 - Free cooling (Economizer)

A = Temperature control

B = Enthalpy control

## Digit 18 - Heat Recovery Module

X = Without

R = Configured for Rotary Wheel

T = Energy Recovery Circuit (ERC)

## Digit 19 - Dehumidification

X = Without

A = With

## Digit 20 - Outdoor coil treatment

B = Without

E = With

## Digit 21 - Indoor coil treatment

1 = Without

2 = With

## Digit 22 - Filtration

A = G4 (50 mm) filters

B = G4 (50 mm) + F7 (100 mm) filters

C = G4 (50 mm) + F9 (100 mm) filters

D = F5 (50 mm) + F7 (100 mm) filters

## Digit 23 - Temperature Zone sensor

X = Without

A = Duct-mounted zone sensor

B = Wall mounted zone sensor

## Digit 24 - Room User Interface

X = Without

A = Wall-mounted interface THS04

B = Conventional thermostat

C = Wall mouted interface PGD1

## Digit 25 - CO<sub>2</sub> sensor

X = Without

1 = CO<sub>2</sub> sensor duct-mounted

2 = CO<sub>2</sub> sensor wall-mounted

## Digit 26 - Smoke detector

X = Without

1 = With

## Digit 27 - Airflow Measurement

X = Without

A = Airflow measurement and display

## Digit 28 - Dirty filter detection

X = Without

1 = With

## Unit Model Number Description

**Digit 29 - Network protection relay**

X = Phase reversal protection  
A = Phase reversal and asymmetry protection

**Digit 30 - Literature Language**

B = Spanish  
C = German  
D = English  
E = French  
J = Italian  
P = Polish  
V = Portuguese

**Digit 31 - Building Pressurization Control**

X = Without  
1 = Barometric relief damper  
2 = Exhaust Fan (ESP=70 Pa)  
3 = Exhaust Fan - High speed (ESP=150 Pa)  
4 = Configured for Return roofcurb

**Digit 32 - not used****Digit 33 - External Customer Input/Output**

X = Without  
1 = With

**Digit 34 - Multi-Rooftop Control**

X = Without  
C = Concierge Tracer Comfort

**Digit 35 - Communication interface**

X = Without  
1 = ModBus communication interface  
2 = LonTalk<sup>®</sup> communications interface  
3 = BACnet (MSTP)  
4 = BACnet IP

**Digit 36 - Not used****Digit 37 - Compressor Starter Type**

X = Across the line  
A = Soft starter

**Digit 38 - Service User Interface**

X = Without  
1 = Service terminal PGD (supplied loose)

**Digit 39 - Fire Thermostat**

X = Without  
1 = With

**Digit 40/41/42/43 - Not used****Digit 44 - Condenser Guard grill**

X = Without  
A = With condenser guard grill

**Digit 45 - Export Packaging**

X = Without  
A = With export packaging

**Digit 46 - Special design**

X = Standard  
S = Special design



# IC - IH General Data

## Single compressor circuit

		IC - IH 039	IC - IH 049	IC - IH 059	IC - IH 064	IC - IH 074	IC - IH 084
<b>Cooling Mode</b>							
Net Cooling Capacity (1)	kW	40.5	50.9	57	65.0	80.5	87.1
Total Power Input (1)	kW	13.0	16.9	20.3	24.8	26.5	30.5
<b>Heating Mode</b>							
Net Heating Capacity (1)	kW	37.9	47.4	53.5	62.8	70.7	78.4
Power Input (1)	kWm	11.7	14.8	17.6	20.4	20.6	23.7
<b>Electric Heater</b>							
Number of capacity step	Nb	2	2	2	2	2	2
Capacity Steps (1)	kW	12,5 / 12,5	12,5 / 12,5	12,5 / 25	12,5 / 25	12,5 / 25	12,5 / 25
<b>Electrical Data (2) (3)</b>							
Main Power Supply	V/Ph/Hz	400 / 3 / 50	400 / 3 / 50	400 / 3 / 50	400 / 3 / 50	400 / 3 / 50	400 / 3 / 50
Unit Max Amps	A	37	43	52	61	66	73
Unit Start Up Amps (without soft starter)	A	124	154	171	183	199	238
Unit Start Up Amps (with soft starter)	A	92	109	123	132	144	169
Maximum Short Circuit rating for 0,3 sec	kA	15	15	15	15	15	15
Max power cable cross section (Standard unit)	mm <sup>2</sup>	35	35	35	35	35	35
Max power cable cross section (unit with option-Heat recovery, Exhaust fan, Return fan, Auxiliary heat)	mm <sup>2</sup>	95	95	95	95	95	95
Disconnect switch std unit		Sirco 125A	Sirco 125A	Sirco 125A	Sirco 125A	Sirco 125A	Sirco 125A
Disconnect switch unit with option (heat recovery, Exhaust fan, Return Fan, Auxiliary heat)		Sirco 250A	Sirco 250A	Sirco 250A	Sirco 250A	Sirco 250A	Sirco 250A
<b>Electrical data of options (2) (3)</b>							
Electric Heater	A	36.1	36.1	54.1	54.1	54.1	54.1
Outdoor fan: Low Ambient	A	3.6	3.6	3.6	3.6	1.6	1.6
Indoor fan: Oversized	A	0.0	0.0	0.0	0.0	0.0	7.4
Exhaust Fan (70pa)	A	0.6	0.6	0.6	0.6	1.2	1.2
Exhaust Fan (150pa)	A	1.0	1.0	1.0	1.0	2.0	2.0
Return Roofcurb	A	5.3	5.3	5.3	9.0	10.6	10.6
Heat Recovery (not included current for oversized fan)	A	7.5	7.5	7.5	7.5	7.5	7.5
Gas burner (staged)	A	0.4	0.4	0.5	0.5	0.5	0.5
Gas burner (modulating)	A	0.3	0.3	0.4	0.4	0.5	0.5
ERC (compressor + exhaust fans)	A	7.9	7.9	7.9	7.9	11.7	11.7
<b>Frame</b>							
Frame		Frame1	Frame1	Frame1	Frame1	Frame2	Frame2
<b>Compressor</b>							
Number of Circuits	#	2	2	2	2	2	2
Number of Compressor per Circuits	#	1	1	1	1	1	1
Type		Scroll	Scroll	Scroll	Scroll	Scroll	Scroll
Model		ZP83KCE TFD 522	ZP104KCE TFD 455	ZP122KCE TFD 455	ZP143KCE TFD 455	SH161-4	SH184-4
Max Amps per Compressor	A	14.3	17.1	20.1	24.5	25.1	32.2
Locked Rotor Amps per Compressor	A	101.0	128.0	139.0	146.0	158.0	197.0
<b>Oil &amp; Refrigerant</b>							
Oil quantity per compressors oil58E/oil57E (6)	l	1.8	2.5	2.5	2.5	3.3	3.6
Oil quantity ckt1/ckt2 oil58E/oil57E (6)	l	1.8/1.8	2.5/2.5	2.5/2.5	2.5/2.5	3.3/3.3	3.6/3.6
Refrigerant charge per circuit (ckt1/ckt2) IH	kg	8.0/8.0	8.5/8.5	8.5/8.5	8.5/8.5	N/A	N/A
Refrigerant charge per circuit (ckt1/ckt2) IC	kg	6.0/6.0	6.0/6.0	8.0/8.0	8.0/8.0	11.0/11.0	11.0/11.0
<b>Outdoor Coil</b>							
Type		Fins & Tubes	Fins & Tubes	Fins & Tubes	Fins & Tubes	Fins & Tubes	Fins & Tubes
Tube Size	Inches	5/16"	5/16"	5/16"	5/16"	5/16"	5/16"
Face Area	m <sup>2</sup>	2.046	2.046	2.046	2.046	2.502	2.502
Rows/Fin Series	#/FPF	2 or 3 / 192	3 / 192	3 / 192	3 / 192	3 / 192	3 / 192
Number of Tubes in the height		48.0	48.0	48.0	48.0	48.0	48.0
<b>Indoor Coil</b>							
Type		Fins & Tubes	Fins & Tubes	Fins & Tubes	Fins & Tubes	Fins & Tubes	Fins & Tubes
Tube Size	Inches	3/8"	3/8"	3/8"	3/8"	3/8"	3/8"
Face Area	m <sup>2</sup>	1.8	1.8	1.8	1.8	2.4	2.4
Rows/Fin Series	#/FPF	3 / 168	3 / 168	3 / 168	3 / 168	4 / 168	4 / 168
Number of Tubes in the height		48.0	48.0	48.0	48.0	48.0	48.0
Drain Connection No./Size	mm	34.0	34.0	34.0	34.0	34.0	34.0
<b>Hot Water Coil</b>							
Type		Fins&Tubes-HWC01	Fins&Tubes-HWC01	Fins&Tubes-HWC01	Fins&Tubes-HWC01	Fins&Tubes-HWC02	Fins&Tubes-HWC02
Tube Size	Inches	3/8"	3/8"	3/8"	3/8"	3/8"	3/8"
Face Area	m <sup>2</sup>	0.769	0.769	0.769	0.769	0.769	1.087
Rows/Fin Series	#/FPF	2 / 144	2 / 144	2 / 144	2 / 144	2 / 144	2/144
Number of Tubes in the height		25.0	25.0	25.0	25.0	25.0	25.0





## IC - IH General Data

### Single compressor circuit (continued)

		IC - IH 039	IC - IH 049	IC - IH 059	IC - IH 064	IC - IH 074	IC - IH 084
<b>Indoor Fan</b>							
<b>Standard</b>							
Type		Plug Fans	Plug Fans	Plug Fans	Plug Fans	Plug Fans	Plug Fans
Model		K3G500PA2371	K3G500PA2371	K3G500PB3301	K3G500PB3301	K3G500PA2371	K3G500PA2371
Minimum Airflow	m <sup>3</sup> /h	6560.0	8000.0	8880.0	10300.0	12400.0	13360.0
Nominal Airflow	m <sup>3</sup> /h	8200.0	10000.0	11100.0	12400.0	15500.0	16700.0
Maximal Airflow	m <sup>3</sup> /h	10660.0	13000.0	14430.0	16120.0	20150.0	21710.0
Number	#	1.0	1.0	1.0	1.0	2.0	2.0
Diameter	mm	500.0	500.0	500.0	500.0	500.0	500.0
Drive Type		EC Motors	EC Motors	EC Motors	EC Motors	EC Motors	EC Motors
Motor Power (Eurovent condition)	kW	0.9	1.4	2.0	2.6	2.1	2.6
Motor Max Amps per fan	A	5.3	5.3	9.0	9.0	5.3	5.3
Motor RPM at nominal flow rate (Eurovent condition)	RPM	1247.5	1502.3	1675.8	1851.0	1321.0	1425.8
Available Static Pressure at nominal flow rate	Pa	250.0	250.0	250.0	250.0	250.0	250.0
<b>Oversized</b>							
Type		Plug Fans	Plug Fans	Plug Fans	Plug Fans	Plug Fans	Plug Fans
Model		K3G500PA2371	K3G500PA2371	K3G500PB3301	K3G500PB3301	K3G500PA2371	K3G500PB3301
Minimum Airflow	m <sup>3</sup> /h	6560	8000	8880	10300	12400	13360
Nominal Airflow	m <sup>3</sup> /h	8200	10000	11100	12400	15500	16700
Maximal Airflow	m <sup>3</sup> /h	10660	13000	14430	16120	20150	21710
Number	#	1	1	1	1	2	2
Diameter	mm	500	500	500	500	500	500
Drive Type		EC Motors	EC Motors	EC Motors	EC Motors	EC Motors	EC Motors
Motor Power (Eurovent condition)	kW	0.9	1.4	2.0	2.6	2.2	2.7
Motor Max Amps per fan	A	5.3	5.3	9.0	9.0	5.3	9.0
Motor RPM at nominal flow rate (Eurovent condition)	RPM	1247.5	1502.3	1675.8	1851.0	1321.0	1422.8
Available Static Pressure at nominal flow rate	Pa	500	500	500	500	500	500
<b>Outdoor Fan</b>							
<b>Standard Ambient</b>							
Type		Axial / Below / AC	Axial / Below / AC	Axial / Below / AC	Axial / Below / AC	Axial / Below / AC	Axial / Below / AC
Model		A6D630AN0101	A6D630AN0101	A6D630AN0101	A6D630AN0101	A8D800A10105	A8D800A10105
Nominal Airflow	m <sup>3</sup> /h	9262.0	9258.7	9256.4	9252.3	14321.0	14317.8
Number of fan / ckt	#	1.0	1.0	1.0	1.0	1.0	1.0
Diameter	mm	630.0	630.0	630.0	630.0	800.0	800.0
Motor Power	kW	0.5	0.5	0.5	0.5	0.7	0.7
Motor Max Amps per fan	A	1.2	1.2	1.2	1.2	2.2	2.2
Motor RPM	rpm	910.0	910.0	910.0	910.0	686.0	686.0
<b>Low Ambient</b>							
Type		Axial / Below / EC	Axial / Below / EC	Axial / Below / EC	Axial / Below / EC	Axial / Below / EC	Axial / Below / EC
Model		A3G800AS3905	A3G800AS3905	A3G800AS3905	A3G800AS3905	A3G800AS3905	A3G800AS3905
Nominal Airflow	m <sup>3</sup> /h	9262.0	9258.7	9256.4	9252.3	14321.0	14317.8
Number	#	1.0	1.0	1.0	1.0	1.0	1.0
Diameter	mm	690.0	690.0	690.0	690.0	690.0	690.0
Motor Power	kW						
Motor Max Amps per fan	A	3.0	3.0	3.0	3.0	3.0	3.0
Motor RPM	rpm	910.0	910.0	910.0	910.0	686.0	686.0
<b>Physical Data for Standard Unit (4)</b>							
Length	mm	3010	3010	3010	3010	3890	3890
Width	mm	2250	2250	2250	2250	2250	2250
Height	mm	1565	1565	1565	1565	1585	1585
IC Operating Weight (Downflow Without Auxiliary Heat)	kg	938	955	992	992	1280	1292
IC Shipping Weight (Downflow Without Auxiliary Heat)	kg	994	1011	1048	1048	1340	1352
IH Operating Weight (Downflow Without Auxiliary Heat)	kg	988	1005	1016	1016	1310	1322
IH Shipping Weight (Downflow Without Auxiliary Heat)	kg	1044	1061	1072	1072	1370	1382
<b>Options Extra Weight (4)</b>							
Hot Water Coil	kg	48	48	48	48	59	59
Electric Heater	kg	22	22	22	22	26	26
Gas Burner: staged	kg	76	76	90	90	116	116
Gas Burner: modulating condensing	kg	76	76	90	90	116	116
Energy Recovery Module	kg	375	375	375	375	455	455
Exhaust Fan	kg	24	24	24	24	39	39
Return Roofcurb Down	kg	380	380	380	390	470	470
Return Roofcurb Horizontal	kg	280	280	280	290	350	350
Downflow Adjustable Roofcurb	kg	150	150	150	150	170	170
Multidirectional Roofcurb	kg	190	190	190	190	220	220



## IC - IH General Data

### Single compressor circuit (continued)

		IC - IH 039	IC - IH 049	IC - IH 059	IC - IH 064	IC - IH 074	IC - IH 084
<b>Energy Recovery Module (ERM)</b>							
Minimum Airflow	m <sup>3</sup> /h	6232.0	7296.0	8816.0	10184.0	11704.0	12920.0
Maximum Airflow	m <sup>3</sup> /h	9348.0	10944.0	13224.0	15276.0	17516.0	19380.0
Exchanger Wheel Diameter	mm	1200.0	1200.0	1200.0	1200.0	1200.0	1200.0
Exhaust Air Fan Diameter	mm	400.0	400.0	400.0	400.0	400.0	400.0
Exhaust Air Fan Motor Power	kW	3.4	3.4	3.4	3.4	3.4	3.4
Length x Width x Height	mm	1750x1180x1510	1750x1180x1510	1750x1180x1510	1750x1180x1510	1750x1180x1510	250x1180x1530
Weight	kg	375.0	375.0	375.0	375.0	375.0	455.0
<b>Gas Burner</b>							
<b>Gas burner type - Basic 2 stages</b>		PRH052	PRH052	PRH072	PRH072	PRH102	PRH102
Thermal output (Hi) [Min-Max]	kW	42,4 - 52,2	42,4 - 52,2	60,0 - 73,5	60,0 - 73,5	81,8 - 100,0	81,8 - 100,0
Useful heat output [Min-Max]	kW	39,6 - 47,9	39,6 - 47,9	56,2 - 67,5	56,2 - 67,5	76,8 - 93,3	76,8 - 93,3
Gas Flow [Min-Max] (5)	m <sup>3</sup> /h	4,49 - 5,52	4,49 - 5,52	6,35 - 7,78	6,35 - 7,78	8,66 - 10,58	8,66 - 10,58
<b>Flue gas emission</b>							
Carbon monoxide - CO - (0% of O <sub>2</sub> ) (5)	ppm	<5	<5	<5	<5	<5	<5
Nitrogen oxides - NOx - (0% of O <sub>2</sub> ) (5)	mg/KWh - ppm	44 - 25	44 - 25	45 - 26	45 - 26	49 - 28	49 - 28
CO <sub>2</sub> max (5)	%	8.8	8.8	8.8	8.8	8.8	8.8
Gas Connection Pipe Diameter		UNI/ISO 228/1-G 3/4"	UNI/ISO 228/1-G 3/4"	UNI/ISO 228/1-G 3/4"	UNI/ISO 228/1-G 3/4"	UNI/ISO 228/1-G 3/4"	UNI/ISO 228/1-G 3/4"
<b>Gas burner type - Premium modulating</b>		PCH045	PCH045	PCH065	PCH065	PCH080	PCH080
Thermal output (Hi) [Min-Max]	kW	8,50 - 42,0	8,50 - 42,0	12,40 - 65,0	12,40 - 65,0	16,40 - 82	16,40 - 82
Useful heat output [Min-Max]	kW	8,97 - 40,45	8,97 - 40,45	13,40 - 62,93	13,40 - 62,93	17,77 - 80,03	17,77 - 80,03
Gas Flow [Min-Max] (5)	m <sup>3</sup> /h	0,90 - 4,45	0,90 - 4,45	1,31 - 6,88	1,31 - 6,88	1,74 - 8,68	1,74 - 8,68
<b>Flue gas emission</b>							
Carbon monoxide - CO - (0% of O <sub>2</sub> ) (5)	ppm	<5	<5	<5	<5	<5	<5
Nitrogen oxides - NOx - (0% of O <sub>2</sub> ) (5)	mg/KWh - ppm	19 - 33	19 - 33	22 - 39	22 - 39	18 - 32	18 - 32
CO <sub>2</sub> max (5)	%	9.1	9.1	9.1	9.1	9.1	9.1
Gas Connection Pipe Diameter		UNI/ISO 228/1-G 3/4"	UNI/ISO 228/1-G 3/4"	UNI/ISO 228/1-G 3/4"	UNI/ISO 228/1-G 3/4"	UNI/ISO 228/1-G 3/4"	UNI/ISO 228/1-G 3/4"
<b>Energy Recovery Circuit (ERC)</b>							
<b>Cooling Mode</b>							
Net Cooling Capacity (ERC only)	kW	15.4	15.6	15.7	15.9	21.3	21.3
ERC Compressor Power Input	kW	3.7	3.7	3.7	3.7	4.1	4.1
ERC Exhaust Fans Power Input	kW	0.5	0.5	0.5	0.5	0.9	0.9
Total ERC Power Input	kW	4.2	4.2	4.2	4.2	5	5
Net Cooling Capacity (ERC + IH standard)	kW	61.3	72.1	77.8	85.5	107.9	114.6
Total Power Input (ERC + IH standard)	kW	17.5	21.5	25.3	29.9	32.9	36.6
<b>Heating Mode</b>							
Net Heating Capacity (ERC only)	kW	15.0	15	15	15	21	21.1
ERC Compressor Power Input	kW	2.4	2.3	2.3	2.3	2.7	2.7
ERC Exhaust Fans Power Input	kW	0.5	0.5	0.5	0.5	0.9	0.9
Total ERC Power Input	kW	2.9	2.8	2.8	2.8	3.6	3.6
Net Heating Capacity (ERC + IH standard)	kW	53.6	63.3	69.5	79.3	93.3	100.3
Total Power Input (ERC + IH standard)	kW	14.2	17.2	19.9	22.8	24.4	27.2
<b>Exhaust Fans &amp; air management (7)</b>							
Number of Exhaust Fans		1	1	1	1	2	2
Exhaust Air Fans Type		Axial / AC	Axial / AC	Axial / AC	Axial / AC	Axial / AC	Axial / AC
Exhaust Air Fans Model		W4D450CO1401	W4D450CO1401	W4D450CO1401	W4D450CO1401	W4D450CO1401	W4D450CO1401
Exhaust Air Fans Diameter	mm	450	450	450	450	450	450
Minimum Fresh Air	%	20	20	20	20	20	20
Maximum Recommended Fresh Air (compared to max airflow)	%	50	41	37	33	51	47
Maximum Fresh Air (building pressurisation issues to be considered)	%	100	100	100	100	100	100
Maximum Return Air Pressure Drop (without Return Roofcurb)	Pa	100	100	100	100	100	100
Maximum Additional Air Pressure Drop (indoor coil)	Pa	10	15	15	20	20	20
<b>Oil &amp; Refrigerant (7)(6)</b>							
ERC Circuit Refrigerant Charge	kg	2.3	2.3	2.3	2.3	2.7	2.7
ERC Circuit Oil Quantity	l	1.24	1.24	1.24	1.24	1.24	1.24
<b>Dimension and weights (7)(6)</b>							
Length x Width x Height (ERC + IH standard)	mm	3010x2250x1565	3010x2250x1565	3010x2250x1565	3010x2250x1565	3890x2250x1585	3890x2250x1585
Weight (ERC + IH standard)	kg	1117	1134	1145	1145	1484	1496

- (1) Indicative performances. For detailed performances, consult order write up (OWU).
- (2) Under 400V/50Hz/3Ph.
- (3) Electrical & system data are indicative and subject to change without notice. Please refer to unit nameplate data.
- (4) Indicative data. For details consult lifting and handling instructions in document package shipped with the unit.
- (5) Value referenced to Cat G20 - for other refer to burner IOM manual.
- (6) OIL058E or OIL057E are European reference for POE oil and can be mixed in any proportion with OIL00078 or OIL00080 (same oil with US reference on compressor nameplate).
- (7) IH unit only.



# IC - IH General Data

## Dual compressor circuit

		IC - IH 040	IC - IH 050	IC - IH 060	IC - IH 065	IC - IH 075	IC - IH 085	IC - IH 100	IC - IH 110	IC - IH 130
<b>Cooling Mode</b>										
Net Cooling Capacity (1)	kW	43.6	53.7	61.0	71.7	82.4	87.5	103.5	113.4	133.4
Total Power Input (1)	kW	13.5	17.3	20.0	23.8	27.2	30.1	34.3	40.4	50.7
<b>Heating Mode</b>										
Net Heating Capacity (1)	kW	38.5	48.8	54.9	63.7	72.3	77.0	92.2	103.8	125.3
Power Input (1)	kWm	11.8	15.0	17.1	19.4	21.2	23.2	26.9	31.3	39.0
<b>Electric Heater</b>										
Number of capacity step	Nb	2	2	2	2	2	2	2	2	2
Capacity Steps (1)	kW	12.5 / 12.5	12.5 / 12.5	12.5 / 25	12.5 / 25	12.5 / 25	12.5 / 25	25 / 37.5	25 / 37,5	25 / 37,5
<b>Electrical Data (2) (3)</b>										
Main Power Supply	V/Ph/Hz	400 / 3 / 50	400 / 3 / 50	400 / 3 / 50	400 / 3 / 50	400 / 3 / 50	400 / 3 / 50	400 / 3 / 50	400 / 3 / 50	400 / 3 / 50
Unit Max Amps	A	42	48	54	63	73	72	92	104	123
Unit Start Up Amps (without soft starter)	A	78	91	111	126	160	159	203	223	244
Unit Start Up Amps (with soft starter)	A	63	73	87	100	124	123	158	174	193
Maximum Short Circuit rating for 0,3 sec	kA	15	15	15	15	15	15	15	15	15
Max power cable cross section (Standard unit)	mm <sup>2</sup>	35	35	35	35	35	35	35	50	50
Max power cable cross section (unit with option-Heat recovery, Exhaust fan, Return fan, Auxiliary heat)	mm <sup>2</sup>	95	95	95	95	95	95	150	150	150
Disconnect switch std unit		Sirco 125A	Sirco 125A	Sirco 125A	Sirco 125A	Sirco 125A	Sirco 125A	Sirco 125A	Sirco 160A	Sirco 160A
Disconnect switch unit with option (heat recovery, Exhaust fan, Return Fan, Auxiliary heat)		Sirco 250A	Sirco 250A	Sirco 250A	Sirco 250A	Sirco 250A	Sirco 250A	Sirco 315A	Sirco 315A	Sirco 315A
<b>Electrical data of options (2) (3)</b>										
Electric Heater	A	36.1	36.1	54.1	54.1	54.1	54.1	90.2	90.2	90.2
Outdoor fan: Low Ambient	A	1.6	1.6	1.6	1.6	1.6	1.6	1.6	1.6	0.0
Indoor fan: Oversized	A	0.0	0.0	0.0	1.2	0.0	7.4	0.0	9.0	9.0
Exhaust Fan (70pa)	A	0.6	0.6	0.6	0.6	1.2	1.2	1.2	1.2	1.2
Exhaust Fan (150pa)	A	1.0	1.0	1.0	1.0	2.0	2.0	2.0	2.0	2.0
Return Roofcurb	A	5.3	5.3	5.3	9.0	10.6	10.6	10.6	10.6	18.0
Heat Recovery (not included current for oversized fan)	A	7.5	7.5	7.5	7.5	7.5	7.5	7.5	7.5	7.5
Gas burner (staged)	A	0.4	0.4	0.5	0.5	0.5	0.5	0.5	0.5	0.5
Gas burner (modulating)	A	0.3	0.3	0.4	0.4	0.5	0.5	0.6	0.6	0.6
ERC (compressor + exhaust fans)	A	7.9	7.9	7.9	7.9	11.7	11.7	16.3	16.3	16.3
<b>Frame</b>										
Frame		Frame1	Frame1	Frame1	Frame1	Frame2	Frame2	Frame3	Frame3	Frame3
<b>Compressor</b>										
Number of Circuits	#	2	2	2	2	2	2	2	2	2
Number of Compressor per Circuits	#	2	2	2	2	2	2	2	2	2
Type		Scroll	Scroll	Scroll	Scroll	Scroll	Scroll	Scroll	Scroll	Scroll
Model		ZP42K5E TFD 422	ZP54K5E TFD 422	ZP61K5E TFD 422	ZP72K5E TFD 422	ZP83K5E TFD 422	ZP91K5E TFD 422	ZP104KCE TFD455	ZP122KCE TFD 455	ZP143KCE TFD 455
Max Amps per Compressor	A	6.9	8.4	9.7	12.1	14.3	13.9	17.1	20.1	24.5
Locked Rotor Amps per Compressor	A	43.0	51.5	67.1	75.0	101.0	101.0	128.0	139.0	146.0
<b>Oil &amp; Refrigerant</b>										
Oil quantity per compressors oil58E/oil57E (6)	l	1.2	1.2	1.2	1.8	1.8	1.8	2.5	2.5	2.5
Oil quantity ckt1/ckt2 oil58E/oil57E (6)	l	2.5/2.5	2.5/2.5	2.5/2.5	3.5/3.5	3.5/3.5	3.5/3.5	5.0/5.0	5.0/5.0	5.0/5.0
Refrigerant charge per circuit (ckt1/ckt2) IH	kg	8.5 / 8.5	8.5 / 8.5	9.0 / 9.0	9.0 / 9.0	11.0 / 11.0	11.0 / 11.0	14.0 / 14.0	14.0 / 14.0	14.0 / 14.0
Refrigerant charge per circuit (ckt1/ckt2) IC	kg	6.0/6.0	6.0/6.0	8.5/8.5	8.5/8.5	11.0/11.0	11.0/11.0	14.0/14.0	14.0/14.0	14.0/14.0
<b>Outdoor Coil</b>										
Type		Fins & Tubes	Fins & Tubes	Fins & Tubes	Fins & Tubes	Fins & Tubes	Fins & Tubes	Fins & Tubes	Fins & Tubes	Fins & Tubes
Tube Size	Inches	5/16"	5/16"	5/16"	5/16"	5/16"	5/16"	5/16"	5/16"	5/16"
Face Area	m <sup>2</sup>	2.046	2.046	2.046	2.046	2.502	2.502	3.128	3.128	3.128
Rows/Fin Series	#/FPF	2 or 3 / 192	2 or 3 / 192	3 / 192	3 / 192	3 / 192	3 / 192	3 / 192	3 / 192	3 / 192
Number of Tubes in the height		48.0	48.0	48.0	48.0	48.0	48.0	60.0	60.0	60.0
<b>Indoor Coil</b>										
Type		Fins & Tubes	Fins & Tubes	Fins & Tubes	Fins & Tubes	Fins & Tubes	Fins & Tubes	Fins & Tubes	Fins & Tubes	Fins & Tubes
Tube Size	Inches	3/8"	3/8"	3/8"	3/8"	3/8"	3/8"	3/8"	3/8"	3/8"
Face Area	m <sup>2</sup>	1.8	1.8	1.8	1.8	2.4	2.4	3.0	3.0	3.0
Rows/Fin Series	#/FPF	3 / 168	3 / 168	3 / 168	4 / 168	4 / 168	4 / 168	4 / 168	4 / 168	4 / 168
Number of Tubes in the height		48.0	48.0	48.0	48.0	48.0	48.0	60.0	60.0	60.0
Drain Connection No./Size	mm	34.0	34.0	34.0	34.0	34.0	34.0	34.0	34.0	34.0
<b>Hot Water Coil</b>										
Type		Fins&Tubes-HWC01	Fins&Tubes-HWC01	Fins&Tubes-HWC01	Fins&Tubes-HWC01	Fins&Tubes-HWC02	Fins&Tubes-HWC02	Fins&Tubes-HWC02	Fins&Tubes-HWC02	Fins&Tubes-HWC02
Tube Size	Inches	3/8"	3/8"	3/8"	3/8"	3/8"	3/8"	3/8"	3/8"	3/8"
Face Area	m <sup>2</sup>	0.769	0.769	0.769	0.769	1.087	1.087	1.087	1.087	1.087
Rows/Fin Series	#/FPF	2 / 144	2 / 144	2 / 144	2 / 144	2/144	2/144	2/144	2/144	2/144
Number of Tubes in the height		25.0	25.0	25.0	25.0	25.0	25.0	25.0	25.0	25.0



# IC - IH General Data

## Dual compressor circuit (continued)

	IC - IH 040	IC - IH 050	IC - IH 060	IC - IH 065	IC - IH 075	IC - IH 085	IC - IH 100	IC - IH 110	IC - IH 130	
<b>Indoor Fan</b>										
<b>Standard</b>										
Type	Plug Fans									
Model	K3G450PA2371	K3G450PA2371	K3G450PA2371	K3G450PA2371	K3G500PA2371	K3G500PA2371	K3G500PB3301	K3G500PB3301	K3G500PB3301	
Minimum Airflow	m <sup>3</sup> /h	6960.0	8480.0	9680.0	10960.0	12560.0	13360.0	15840.0	17280.0	20400.0
Nominal Airflow	m <sup>3</sup> /h	8700.0	10600.0	12100.0	13700.0	15700.0	16700.0	19800.0	21600.0	25500.0
Maximal Airflow	m <sup>3</sup> /h	11310.0	13780.0	15730.0	17810.0	20410.0	21710.0	25740.0	28080.0	33150.0
Number	#	2.0	2.0	2.0	2.0	2.0	2.0	2.0	2.0	2.0
Diameter	mm	450.0	450.0	450.0	450.0	500.0	500.0	500.0	500.0	500.0
Drive Type	EC Motors									
Motor Power (Eurovent condition)	kW	1.1	1.2	1.4	2.2	2.3	2.6	3.3	3.9	5.7
Motor Max Amps per fan	A	4.7	4.7	4.7	4.7	5.3	5.3	9.0	9.0	9.0
Motor RPM at nominal flow rate (Eurovent condition)	RPM	1091.8	1242.4	1332.2	1573.4	1357.9	1425.8	1586.7	1681.8	1941.5
Available Static Pressure at nominal flow rate	Pa	250.0	250.0	250.0	250.0	250.0	250.0	250.0	250.0	250.0
<b>Oversized</b>										
Type	Plug Fans									
Model	K3G450PA2371	K3G450PA2371	K3G450PA2371	K3G500PA2371	K3G500PA2371	K3G500PB3301	K3G500PB3301	K3G500PB3301	K3G500PB3301	
Minimum Airflow	m <sup>3</sup> /h	6960	8480	9680	10960	12560	13360	15840	17280	20400
Nominal Airflow	m <sup>3</sup> /h	8700	10600	12100	13700	15700	16700	19800	21600	25500
Maximal Airflow	m <sup>3</sup> /h	11310	13780	15730	17810	20410	21710	25740	28080	33150
Number	#	2	2	2	2	2	2	2	3	3
Diameter	mm	450	450	450	500	500	500	500	500	500
Drive Type	EC Motors									
Motor Power (Eurovent condition)	kW	1.1	1.2	1.4	2.1	2.3	2.7	3.3	3.2	4.5
Motor Max Amps per fan	A	4.7	4.7	4.7	5.3	5.3	9.0	9.0	9.0	9.0
Motor RPM at nominal flow rate (Eurovent condition)	RPM	1091.8	1242.4	1332.2	1281.1	1357.9	1422.8	1586.7	1294.9	1470.6
Available Static Pressure at nominal flow rate	Pa	500	500	500	500	500	500	500	500	500
<b>Outdoor Fan</b>										
<b>Standard Ambient</b>										
Type	Axial / Below / AC	Axial / Below / AC	Axial / Below / AC	Axial / Below / AC	Axial / Below / AC	Axial / Below / AC	Axial / Below / AC	Axial / Below / AC	Axial / Below / AC	Axial / Below / EC
Model	A8D800A10105 A8D800A10105 A8D800A10105 A8D800A10105 A8D800A10105 A8D800A10105 A8D800A10105 A8D800A10105 A8D800A10105 A3G800AS3905									
Nominal Airflow	m <sup>3</sup> /h	13694.0	13687.1	13681.4	13674.7	14321.0	14317.8	14865.3	14859.9	19628.3
Number of fan / ckt	#	1.0	1.0	1.0	1.0	1.0	1.0	1.0	1.0	1.0
Diameter	mm	800.0	800.0	800.0	800.0	800.0	800.0	800.0	800.0	800.0
Motor Power	kW	0.7	0.7	0.7	0.7	0.7	0.7	0.7	0.7	1.3
Motor Max Amps per fan	A	2.2	2.2	2.2	2.2	2.2	2.2	2.2	2.2	3.0
Motor RPM	rpm	686.0	686.0	686.0	686.0	686.0	686.0	686.0	686.0	900.0
<b>Low Ambient</b>										
Type	Axial / Below / EC	Axial / Below / EC	Axial / Below / EC	Axial / Below / EC	Axial / Below / EC	Axial / Below / EC	Axial / Below / EC	Axial / Below / EC	Axial / Below / EC	Axial / Below / EC
Model	A3G800AS3905 A3G800AS3905 A3G800AS3905 A3G800AS3905 A3G800AS3905 A3G800AS3905 A3G800AS3905 A3G800AS3905 A3G800AS3905 A3G800AS3905									
Nominal Airflow	m <sup>3</sup> /h	13694.0	13687.1	13681.4	13674.7	14321.0	14317.8	14865.3	14859.9	19628.3
Number	#	1.0	1.0	1.0	1.0	1.0	1.0	1.0	1.0	1.0
Diameter	mm	690.0	690.0	690.0	690.0	690.0	690.0	690.0	690.0	930.0
Motor Power	kW									
Motor Max Amps per fan	A	3.0	3.0	3.0	3.0	3.0	3.0	3.0	3.0	3.0
Motor RPM	rpm	686.0	686.0	686.0	686.0	686.0	686.0	686.0	686.0	900.0
<b>Physical Data for Standard Unit (4)</b>										
Length	mm	3010	3010	3010	3010	3890	3890	3890	3890	3890
Width	mm	2250	2250	2250	2250	2250	2250	2250	2250	2250
Height	mm	1565	1565	1565	1565	1585	1585	1890	1890	1890
IC Operating Weight (Downflow Without Auxiliary Heat)	kg	1050	1062	1092	1129	1311	1317	1533	1537	1537
IC Shipping Weight (Downflow Without Auxiliary Heat)	kg	1106	1118	1148	1185	1371	1377	1593	1597	1597
IH Operating Weight (Downflow Without Auxiliary Heat)	kg	1100	1112	1116	1153	1342	1348	1566	1570	1570
IH Shipping Weight (Downflow Without Auxiliary Heat)	kg	1156	1168	1172	1209	1402	1408	1626	1630	1630
<b>Options Extra Weight (4)</b>										
Hot Water Coil	kg	48	48	48	48	59	59	65	65	65
Electric Heater	kg	22	22	22	22	26	26	29	29	29
Gas Burner: staged	kg	76	76	90	90	118	118	118	118	118
Gas Burner: modulating condensing	kg	76	76	90	90	118	118	138	138	138
Energy Recovery Module	kg	375	375	375	375	455	455	535	535	535
Exhaust Fan	kg	24	24	24	24	39	39	43	43	43
Return Roofcurb Down	kg	380	380	380	390	470	470	470	470	490
Return Roofcurb Horizontal	kg	280	280	280	290	350	350	350	350	370
Downflow Adjustable Roofcurb	kg	150	150	150	150	170	170	170	170	170
Multidirectional Roofcurb	kg	190	190	190	190	220	220	220	220	220

# IC - IH General Data

## Dual compressor circuit (continued)

		IC - IH 040	IC - IH 050	IC - IH 060	IC - IH 065	IC - IH 075	IC - IH 085	IC - IH 100	IC - IH 110	IC - IH 130
<b>Energy Recovery Module (ERM)</b>										
Minimum Airflow	m <sup>3</sup> /h	6232.0	7296.0	8816.0	10184.0	11704.0	12920.0	15200.0	17480.0	20216.0
Maximum Airflow	m <sup>3</sup> /h	9348.0	10944.0	13224.0	15276.0	17556.0	19380.0	22800.0	26220.0	30324.0
Exchanger Wheel Diameter	mm	1200.0	1200.0	1200.0	1200.0	1200.0	1200.0	1500.0	1500.0	1500.0
Exhaust Air Fan Diameter	mm	400.0	400.0	400.0	400.0	400.0	400.0	400.0	400.0	400.0
Exhaust Air Fan Motor Power	kW	3.4	3.4	3.4	3.4	3.4	3.4	3.4	3.4	3.4
Length x Width x Height	mm	1750x1180x1510	1750x1180x1510	1750x1180x1510	1750x1180x1510	2250x1180x1530	2250x1180x1530	2250x1180x1835	2250x1180x1835	2250x1180x1835
Weight	kg	375.0	375.0	375.0	375.0	455.0	455.0	535.0	535.0	535.0
<b>Gas Burner</b>										
<b>Gas burner type - Basic 2 stages</b>		PRH052	PRH052	PRH072	PRH072	PRH102	PRH102	PRH102	PRH102	PRH102
Thermal output (Hi) [Min-Max]	kW	42,4 - 52,2	42,4 - 52,2	60,0 - 73,5	60,0 - 73,5	81,8 - 100,0	81,8 - 100,0	81,8 - 100,0	81,8 - 100,0	81,8 - 100,0
Useful heat output [Min-Max]	kW	39,6 - 47,9	39,6 - 47,9	56,2 - 67,5	56,2 - 67,5	76,8 - 93,3	76,8 - 93,3	76,8 - 93,3	76,8 - 93,3	76,8 - 93,3
Gas Flow [Min-Max] (5)	m <sup>3</sup> /h	4,49 - 5,52	4,49 - 5,52	6,35 - 7,78	6,35 - 7,78	8,66 - 10,58	8,66 - 10,58	8,66 - 10,58	8,66 - 10,58	8,66 - 10,58
<b>Flue gas emission</b>										
Carbon monoxide - CO - (0% of O <sub>2</sub> ) (5)	ppm	<5	<5	<5	<5	<5	<5	<5	<5	<5
Nitrogen oxides - NOx - (0% of O <sub>2</sub> ) (5)	mg/KWh -ppm	44 - 25	44 - 25	45 - 26	45 - 26	49 - 28	49 - 28	49 - 28	49 - 28	49 - 28
CO <sub>2</sub> max (5)	%	8.8	8.8	8.8	8.8	8.8	8.8	8.8	8.8	8.8
Gas Connection Pipe Diameter		UNI/ISO 228/1-G 3/4"	UNI/ISO 228/1-G 3/4"	UNI/ISO 228/1-G 3/4"	UNI/ISO 228/1-G 3/4"	UNI/ISO 228/1-G 3/4"	UNI/ISO 228/1-G 3/4"	UNI/ISO 228/1-G 3/4"	UNI/ISO 228/1-G 3/4"	UNI/ISO 228/1-G 3/4"
<b>Gas burner type - Premium modulating</b>		PCH045	PCH045	PCH065	PCH065	PCH080	PCH080	PCH105	PCH105	PCH105
Thermal output (Hi) [Min-Max]	kW	8,50 - 42,0	8,50 - 42,0	12,40 - 65,0	12,40 - 65,0	16,40 - 82	16,40 - 82	21,0 - 100,0	21,0 - 100,0	21,0 - 100,0
Useful heat output [Min-Max]	kW	8,97 - 40,45	8,97 - 40,45	13,40 - 62,93	13,40 - 62,93	17,77 - 80,03	17,77 - 80,03	22,77 - 97,15	22,77 - 97,15	22,77 - 97,15
Gas Flow [Min-Max] (5)	m <sup>3</sup> /h	0,90 - 4,45	0,90 - 4,45	1,31 - 6,88	1,31 - 6,88	1,74 - 8,68	1,74 - 8,68	2,22 - 10,58	2,22 - 10,58	2,22 - 10,58
<b>Flue gas emission</b>										
Carbon monoxide - CO - (0% of O <sub>2</sub> ) (5)	ppm	<5	<5	<5	<5	<5	<5	<5	<5	<5
Nitrogen oxides - NOx - (0% of O <sub>2</sub> ) (5)	mg/KWh -ppm	19 - 33	19 - 33	22 - 39	22 - 39	18 - 32	18 - 32	23 - 41	23 - 41	23 - 41
CO <sub>2</sub> max (5)	%	9.1	9.1	9.1	9.1	9.1	9.1	9.1	9.1	9.1
Gas Connection Pipe Diameter		UNI/ISO 228/1-G 3/4"	UNI/ISO 228/1-G 3/4"	UNI/ISO 228/1-G 3/4"	UNI/ISO 228/1-G 3/4"	UNI/ISO 228/1-G 3/4"	UNI/ISO 228/1-G 3/4"	UNI/ISO 228/1-G 3/4"	UNI/ISO 228/1-G 3/4"	UNI/ISO 228/1-G 3/4"
<b>Energy Recovery Circuit (ERC)</b>										
<b>Cooling Mode</b>										
Net Cooling Capacity (ERC only)	kW	15.5	15.7	15.8	16	21.3	21.4	26.5	26.7	27
ERC Compressor Power Input	kW	3.7	3.7	3.7	3.7	4.1	4.1	5.9	5.9	5.9
ERC Exhaust Fans Power Input	kW	0.5	0.5	0.5	0.5	0.9	0.9	0.9	0.9	0.9
Total ERC Power Input	kW	4.2	4.2	4.2	4.2	5	5	6.8	6.8	6.8
Net Cooling Capacity (ERC + IH standard)	kW	64.6	76.1	84.5	93	111.3	115.5	137.5	147.7	170
Total Power Input (ERC + IH standard)	kW	17.7	21.3	23.9	28.9	33.4	36.4	42.4	48.4	59.1
<b>Heating Mode</b>										
Net Heating Capacity (ERC only)	kW	15	15	14.9	15	21.1	21.1	27	27	27
ERC Compressor Power Input	kW	2.4	2.3	2.3	2.3	2.7	2.7	3.9	3.9	3.8
ERC Exhaust Fans Power Input	kW	0.5	0.5	0.5	0.5	0.9	0.9	0.9	0.9	0.9
Total ERC Power Input	kW	2.9	2.8	2.8	2.8	3.6	3.6	4.8	4.8	4.7
Net Heating Capacity (ERC + IH standard)	kW	54.2	64.7	70.9	80.3	94.7	100	120.8	132.9	154.8
Total Power Input (ERC + IH standard)	kW	14.3	17.3	19.9	21.9	24.7	26.4	31.6	35.4	42.8
<b>Exhaust Fans &amp; air management (7)</b>										
Number of Exhaust Fans		1	1	1	1	2	2	2	2	2
Exhaust Air Fans Type		Axial / AC	Axial / AC	Axial / AC	Axial / AC	Axial / AC	Axial / AC	Axial / AC	Axial / AC	Axial / AC
Exhaust Air Fans Model		W4D450CO1401	W4D450CO1401	W4D450CO1401	W4D450CO1401	W4D450CO1401	W4D450CO1401	W4D450CO1401	W4D450CO1401	W4D450CO1401
Exhaust Air Fans Diameter	mm	450	450	450	450	450	450	450	450	450
Minimum Fresh Air	%	20	20	20	20	20	20	20	20	20
Maximum Recommended Fresh Air (compared to max airflow)	%	47	39	34	30	50	47	41	38	32
Maximum Fresh Air (building pressurisation issues to be considered)	%	100	100	100	100	100	100	100	100	100
Maximum Return Air Pressure Drop (without Return Roofcurb)	Pa	100	100	100	100	100	100	100	100	100
Maximum Additional Air Pressure Drop (indoor coil)	Pa	10	15	25	25	20	20	20	25	25
<b>Oil &amp; Refrigerant (7)(6)</b>										
ERC Circuit Refrigerant Charge	kg	2.3	2.3	2.3	2.3	2.7	2.7	3.4	3.4	3.4
ERC Circuit Oil Quantity	l	1.24	1.24	1.24	1.24	1.24	1.24	1.24	1.24	1.24
<b>Dimensions and weights (7)(6)</b>										
Length x Width x Height (ERC + IH standard)	mm	3010x2250x1565	3010x2250x1565	3010x2250x1565	3010x2250x1565	3890x2250x1585	3890x2250x1585	3890x2250x1585	3890x2250x1585	3890x2250x1585
Weight (ERC + IH standard)	kg	1229	1241	1245	1282	1516	1522	1751	1755	1755

(1) Indicative performances. For detailed performances, consult order write up (OWU).

(2) Under 400V/50Hz/3Ph.

(3) Electrical & system data are indicative and subject to change without notice. Please refer to unit nameplate data.

(4) Indicative data. For details consult lifting and handling instructions in document package shipped with the unit.

(5) Value referenced to Cat G20 - for other refer to burner IOM manual.

(6) OIL058E or OIL057E are European reference for POE oil and can be mixed in any proportion with OIL00078 or OIL00080 (same oil with US reference on compressor nameplate).

(7) IH unit only.



# IC General Data

## Single circuit

		IC 038	IC 048	IC 058	IC 063
<b>Cooling Mode</b>					
Net Cooling Capacity (1)	kW	41.4	50.1	60.5	69.2
Total Power Input (1)	kW	14.0	16.6	20.7	25.1
<b>Electric Heater</b>					
Number of capacity step	Nb	2	2	2	2
Capacity Steps (1)	kW	12,5 / 12,5	12,5 / 12,5	12,5 / 25	12,5 / 25
<b>Electrical Data (2) (3)</b>					
Main Power Supply	V/Ph/Hz	400 / 3 /50	400 / 3 /50	400 / 3 /50	400 / 3 /50
Unit Max Amps	A	37	45	54	63
Unit Start Up Amps (without soft starter)	A	124	156	173	185
Unit Start Up Amps (with soft starter)	A	88	111	125	134
Maximum Short Circuit rating for 0.3 sec	kA	15	15	15	15
Max power cable cross section (Standard unit)	mm <sup>2</sup>			35	
Max power cable cross section (unit with option-Heat recovery, Exhaust fan, Return fan, Auxiliary heat)	mm <sup>2</sup>			95	
Disconnect switch std unit				Sirco 125A	
Disconnect switch unit with option (heat recovery, Exhaust fan, Return Fan, Auxiliary heat)				Sirco 250A	
Electric Heater	A	36.1	36.1	36.1	36.1
Outdoor fan: Low Ambient	A	0.8	1.6	1.6	1.6
Indoor fan: Oversized	A	0.0	0.0	0.0	0.0
Exhaust Fan (70pa)	A	0.6	0.6	0.6	0.6
Exhaust Fan (150pa)	A	1.0	1.0	1.0	1.0
Return Roofcurb	A	5.3	5.3	5.3	5.3
Heat Recovery (not included current for oversized fan)	A	7.5	7.5	7.5	7.5
Gas burner (staged)	A	0.4	0.4	0.4	0.4
Gas burner (modulating)	A	0.3	0.3	0.3	0.3
<b>Frame</b>					
Frame		Frame 1	Frame 1	Frame 1	Frame 1
<b>Compressor</b>					
Number of Circuits	#	1	1	1	1
Number of Compressor per Circuits	#	2	2	2	2
Type		Scroll	Scroll	Scroll	Scroll
Model		ZP83KCE TFD 422	ZP104KCE TFD455	ZP122KCE TFD 455	ZP143KCE TFD 455
Max Amps per Compressor	A	14.3	17.1	20.1	24.5
Locked Rotor Amps per Compressor	A	101	128	139	146
<b>Oil &amp; Refrigerant</b>					
Oil quantity per compressors oil58E/oil57E (6)	l	1.8	2.5	2.5	2.5
Oil quantity oil58E/oil57E (6)	l	3.5/3.5	5.0/5.0	5.0/5.0	5.0/5.0
Refrigerant charge per circuit	kg	4.33	7.44	7.20	7.70
<b>Outdoor Coil</b>					
Type		MCHE	MCHE	MCHE	MCHE
Tube Size	Inches				
Face Area	m <sup>2</sup>	2.92	2.92	2.92	2.92
Rows/Fin Series	#/FPF				
Number of Tubes in the height		128 (96-32)	128 (96-32)	128 (96-32)	128 (96-32)
<b>Indoor Coil</b>					
Type		Fins & Tubes	Fins & Tubes	Fins & Tubes	Fins & Tubes
Tube Size	Inches	3/8"	3/8"	3/8"	3/8"
Face Area	m <sup>2</sup>	1.812	1.812	1.812	1.812
Rows/Fin Series	#/FPF	3 / 168	3 / 168	3 / 168	3 / 168
Number of Tubes in the height		48	48	48	48
Drain Connection No./Size	mm	34	34	34	34
<b>Hot Water Coil</b>					
Type		Fins & Tubes	Fins & Tubes	Fins & Tubes	Fins & Tubes
Tube Size	Inches	3/8"	3/8"	3/8"	3/8"
Face Area	m <sup>2</sup>	0.769	0.769	0.769	0.769
Rows/Fin Series	#/FPF	2 / 144	2 / 144	2 / 144	2 / 144
Number of Tubes in the height		25	25	25	25
<b>Indoor Fan</b>					
<b>Standard</b>					
Type		Plug Fans	Plug Fans	Plug Fans	Plug Fans
Model		K3G500PA2371	K3G500PA2371	K3G500PB3301	K3G500PB3301
Minimum Airflow	m <sup>3</sup> /h	6240	7200	8880	10300
Nominal Airflow	m <sup>3</sup> /h	7800	9000	11100	12400
Maximal Airflow	m <sup>3</sup> /h	10140	11700	14430	16120
Number	#	1	1	1	1
Diameter	mm	500	500	500	500
Drive Type		EC Motors	EC Motors	EC Motors	EC Motors
Motor Power (Eurovent condition)	kW	0.93	1.15	1.91	2.59
Motor Max Amps per fan	A	5.3	5.3	9	9
Motor RPM at nominal flow rate (Eurovent condition)	RPM	1221	1362		
Available Static Pressure at nominal flow rate	Pa	250	250	250	250

## IC General Data

### Single circuit

		IC 038	IC 048	IC 058	IC 063
Type		Plug Fans	Plug Fans	Plug Fans	Plug Fans
Model		K3G500PA2371	K3G500PA2371	K3G500PB3301	K3G500PB3301
Minimum Airflow	m <sup>3</sup> /h	6560	8000	8880	10300
Nominal Airflow	m <sup>3</sup> /h	8200	10000	11100	12400
Maximal Airflow	m <sup>3</sup> /h	10660	13000	14430	16120
Number	#	1	1	1	1
Diameter	mm	500	500	500	500
Drive Type		EC Motors	EC Motors	EC Motors	EC Motors
Motor Power (Eurovent condition)	kW	0.929	1.15	1.91	2.59
Motor Max Amps per fan	A	5.3	5.3	9	9
Motor RPM at nominal flow rate (Eurovent condition)	RPM	1221	1362	1632	1829
Available Static Pressure at nominal flow rate	Pa	500	500	500	500
<b>Standard Ambient</b>					
Type		Axial / Below / AC	Axial / Below / AC	Axial / Below / AC	Axial / Below / AC
Model		A8D800A10105	A8D800A10105	A8D800A10105	A8D800A10105
Nominal Airflow / ckt	m <sup>3</sup> /h	14543	12078.5	12078.5	12078.5
Number of fan / ckt	#	1	2	2	2
Diameter	mm	800	800	800	800
Motor Power	kW	0.68	0.7	0.7	0.7
Motor Max Amps per fan	A	2.22	2.22	2.22	2.22
Motor RPM	rpm	686	686	686	686
<b>Low Ambient</b>					
Type		Axial / Below / EC	Axial / Below / EC	Axial / Below / EC	Axial / Below / EC
Model		A3G800AS3905	A3G800AS3905	A3G800AS3905	A3G800AS3905
Nominal Airflow	m <sup>3</sup> /h	7433	12078	12078	120278
Number	#	1	2	2	2
Diameter	mm	800	800	800	800
Motor Power	kW	0.6	0.7	0.7	0.7
Motor Max Amps per fan	A	3	3	3	3
Motor RPM	rpm	686	686	686	686
<b>Physical Data for Standard Unit</b>					
Length	mm	2830	2830	2830	2830
Width	mm	2250	2250	2250	2250
Height	mm	1565	1565	1565	1565
IC Operating Weight (Downflow Without Auxiliary Heat)	kg	864	924	935	935
IC Shipping Weight (Downflow Without Auxiliary Heat)	kg	920	980	991	991
<b>Options Extra Weight (4)</b>					
Hot Water Coil	kg	48	48	48	48
Electric Heater	kg	22	22	22	22
Gas Burner: staged	kg	76	76	90	90
Gas Burner: modulating condensing	kg	76	76	90	90
Energy Recovery Module	kg	375	375	375	375
Exhaust Fan	kg	24	24	24	24
Return Roofcurb Down	kg	380	380	380	390
Return Roofcurb Horizontal	kg	280	280	280	290
Downflow Adjustable Roofcurb	kg	150	150	150	150
Multidirectional Roofcurb	kg	190	190	190	190
<b>Energy Recovery Module (ERM)</b>					
Minimum Airflow	m <sup>3</sup> /h	6232	7296	8816	10184
Maximum Airflow	m <sup>3</sup> /h	9348	10944	13224	15276
Exchanger Wheel Diameter	mm	1200	1200	1200	1200
Exhaust Air Fan Diameter	mm	400	400	400	400
Exhaust Air Fan Motor Power	kW	3.35	3.35	3.35	3.35
External Static Pressure	Pa				
Length x Width x Height	mm	1750x1180x1510	1750x1180x1510	1750x1180x1510	1750x1180x1510
Weight	kg	375	375	375	375
<b>Gas Burner</b>					
<b>Gas burner type - Basic 2 stages</b>		PRH052	PRH052	PRH072	PRH072
Thermal output (Hi) [Min-Max]	kW	42,4 - 52,2	42,4 - 52,2	60,0 - 73,5	60,0 - 73,5
Useful heat output [Min-Max]	kW	39,6 - 47,9	39,6 - 47,9	56,2 - 67,5	56,2 - 67,5
Gas Flow [Min-Max] (5)	m <sup>3</sup> /h	4,49 - 5,52	4,49 - 5,52	6,35 - 7,78	6,35 - 7,78
<b>Flue gas emission</b>					
Carbon monoxide - CO - (0% of O <sub>2</sub> ) (5)	ppm	<5	<5	<5	<5
Nitrogen oxides - NOx - (0% of O <sub>2</sub> ) (6)	mg/KWh - ppm	44 - 25	44 - 25	45 - 26	45 - 26
CO <sub>2</sub> max (5)	%	8.8	8.8	8.8	8.8
Gas Connection Pipe Diameter		UNI/ISO 228/1-G 3/4"	UNI/ISO 228/1-G 3/4"	UNI/ISO 228/1-G 3/4"	UNI/ISO 228/1-G 3/4"
<b>Gas burner type - Premium modulating</b>		PCH045	PCH045	PCH065	PCH065
Thermal output (Hi) [Min-Max]	kW	8,50 - 42,0	8,50 - 42,0	12,40 - 65,0	12,40 - 65,0

## IC General Data

### Single circuit

		<b>IC 038</b>	<b>IC 048</b>	<b>IC 058</b>	<b>IC 063</b>
Useful heat output [Min-Max]	kW	8,97 - 40,45	8,97 - 40,45	13,40 - 62,93	13,40 - 62,93
Gas Flow [Min-Max] (5)	m <sup>3</sup> /h	0,90 - 4,45	0,90 - 4,45	1,31 - 6,88	1,31 - 6,88
<b>Flue gas emission</b>					
Carbon monoxide - CO - (0% of O <sub>2</sub> ) (5)	ppm	<5	<5	<5	<5
Nitrogen oxides - NOx - (0% of O <sub>2</sub> ) (6)	mg/KWh -ppm	19 - 33	19 - 33	22 - 39	22 - 39
CO <sub>2</sub> max (5)	%	9.1	9.1	9.1	9.1
Gas Connection Pipe Diameter		UNI/ISO 228/1-G 3/4"	UNI/ISO 228/1-G 3/4"	UNI/ISO 228/1-G 3/4"	UNI/ISO 228/1-G 3/4"

(1) Indicative performances. For detailed performances, consult order write up (OWU).

(2) Under 400V/50Hz/3Ph.

(3) Electrical & system data are indicative and subject to change without notice. Please refer to unit nameplate data.

(4) Indicative data. For details consult lifting and handling instructions in document package shipped with the unit.

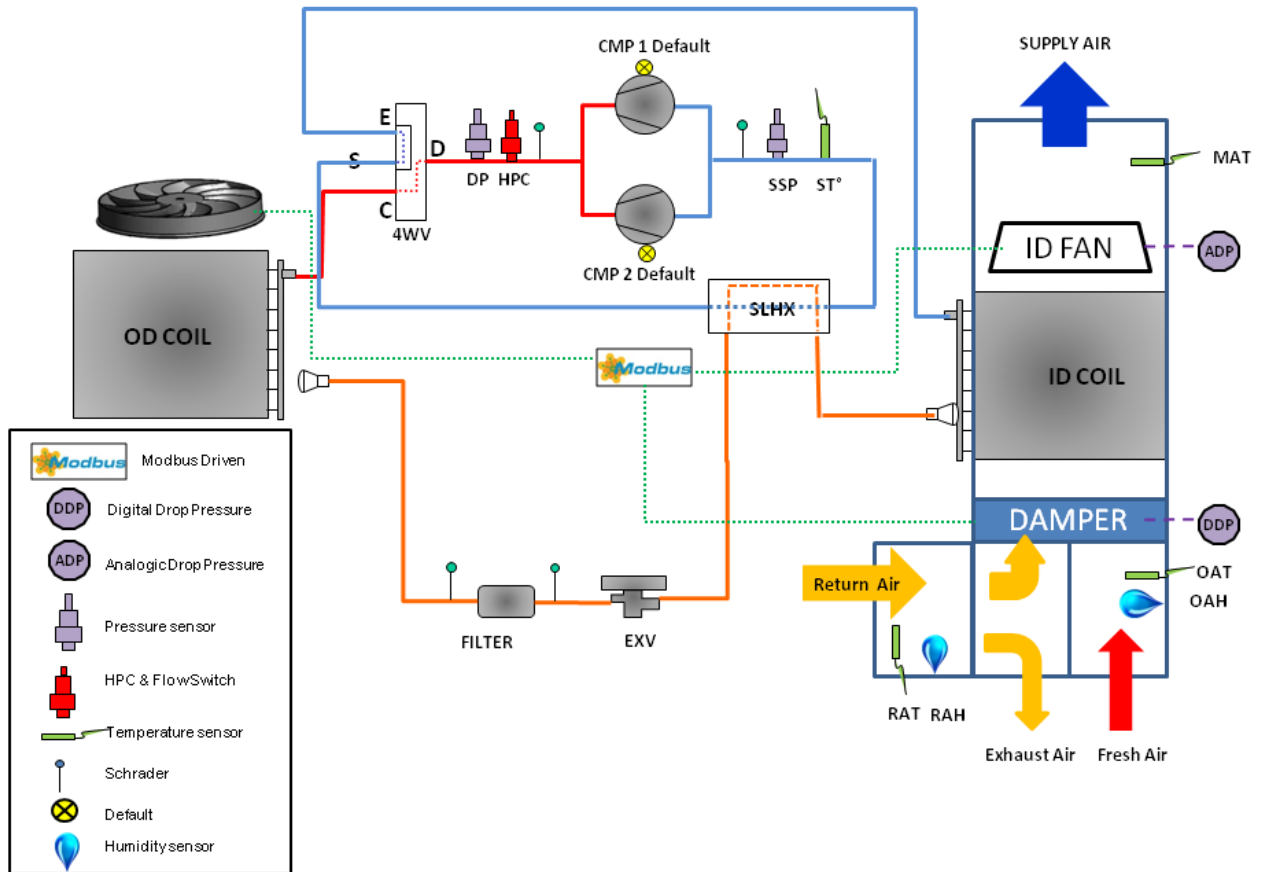
(5) Value referenced to Cat G20 - for other refer to burner IOM manual.

(6) OIL058E or OIL057E are European reference for POE oil and can be mixed in any proportion with OIL00078 or OIL00080 (same oil with US reference on compressor nameplate).



# Unit Operating Principle

Figure 1



# Installation

**General information: The installation must conform to all local standards and regulations.**

## Reception of Units

### Unit Handling

The unit is supplied on wooden blocks. It is recommended to check the machine's condition upon reception.

There are two ways to handle the unit:

- 1) Handle the machine using a forklift, in accordance with applicable safety regulations. Handling of the unit is prohibited unless forks are longer than the length of the unit (not recommended as there is a risk of damage if not done carefully).
- 2) Use a lifting beam correctly adjusted to fit the unit (recommended).

The units are supplied on the truck but are not unloaded. A lifting lug is provided on each corner of the unit's base to facilitate handling. 4 shackles and 4 slings are required.

Use a lifting beam to prevent the cables pressing too hard on top of the unit during lifting.

**Important:** For unit to fit on the roof curb the wooden blocks must be removed.

### Lifting and moving Instructions

Specific lifting method is recommended as follows:

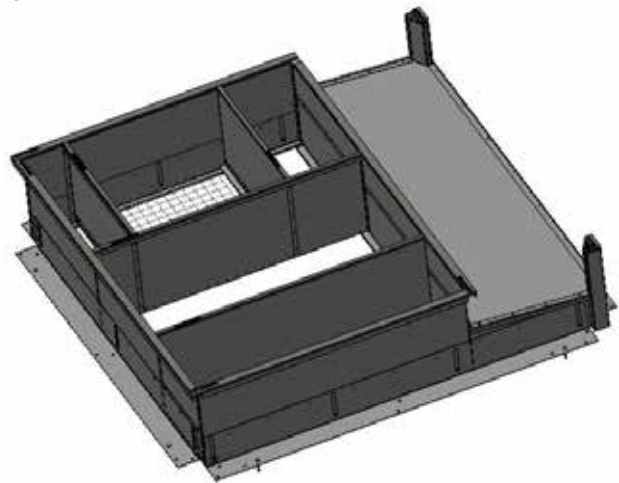
- 1 - The units are supplied with four lifting points
- 2 - Slings and spreader bar to be provided by rigger and attached to the four lifting points.
- 3 - Minimum rated lifting capacity (vertical) of each sling and spreader bar shall be no less than the unit shipping weight.
- 4 - Caution: The unit must be lifted with the utmost care. Avoid shock load by lifting slowly and evenly.
- 5 - Remove slings and spreader bars when installation is completed.

The detailed handling, lifting instructions including all weights and sling lengths are given on the specific drawings and instructions shipped with the unit.

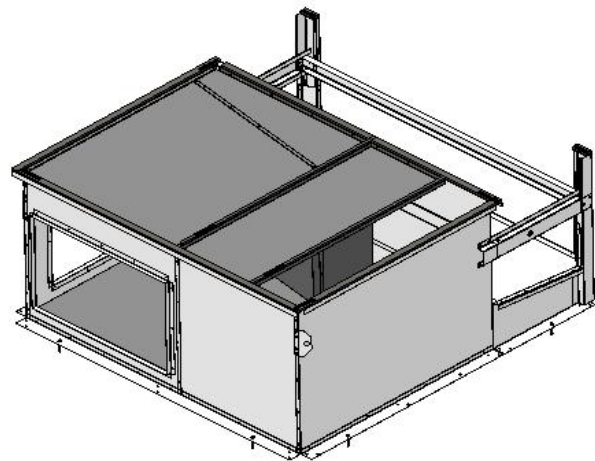
## Roof Curb Installation

Roof curbs are available as an accessory for "downflow" units to support the unit and ensure the water tightness between the rooftop and the roof. Four types of roofcurbs are available: the standard version to allow the installation of the unit on a flat roof with different return flow patterns (return roofcurb down, return roofcurb horizontal, multidirectional roofcurb) and the adjustable version for a slope roof installation (adjustable roofcurb down). The roofcurb characteristic is given in roofcurb submittal drawings sent with the unit.

*Figure 2 - Roofcurb down*



*Figure 3 - Roofcurb multidirectional assembly*

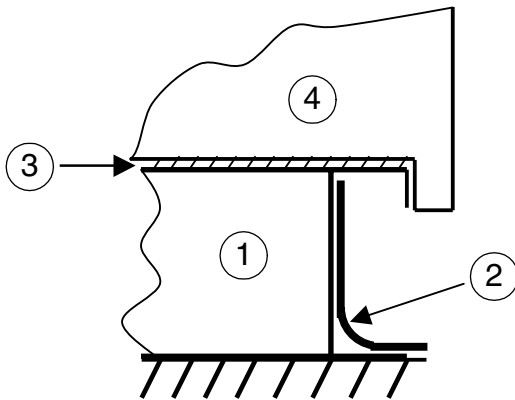


**Instructions for the roofcurb assembly and installation with curb dimensions are provided with each roofcurb kit.**

In order to insure watertightness of the roofcurb assembly, it is important to respect the schematics below and to consult the booklet for roofcurb assembly shipped with the roofcurb module. Be sure that gasket is positioned on the roofcurb and without damage before unit positioning.

To avoid any property damage or personal injury, it is the installer's responsibility to make sure that the installation will not impair the function of this curb, or the unit to be installed; and that the roofcurb and unit must be completely sealed, preventing any water or air leakage damage.

**Figure 4 - Waterproofing**



- 1. Roofcurb
- 2. Roof membrane
- 3. Seal
- 4. Rooftop

## Installing the Unit

The structure accommodating the unit(s) must be designed to support the equipment in operation, as a minimum. Refer to submittals drawings supplied with the unit for dimensions, weight and clearance requirement around unit.

### Unit support

Install the unit on a flat foundation strong enough to support unit loading and level (within 5 mm across the length and width of the unit). If the unit is to be roof mounted check the building codes for weight distribution requirements

### Location and clearances

Choose a location that will enable air to circulate freely in the condenser coil and allow air to be discharged above the fans. The clearance distances for air circulation and maintenance are indicated in the submittals drawings.

### Placing and rigging

The rooftop units are designed to be installed outdoor and must be positioned horizontally (vertical air discharge off the condenser).

### Slab mount

For ground level installation, the unit base should be adequately supported and hold the unit near level.

In areas where snowfall is common, the unit must be elevated enough to ensure that the bottom of the outdoor coil is above the height of the expected snow accumulation.

Where severely cold temperatures are a consideration, elevation of the unit is again recommended to ensure that defrost water does not create an ice build up that will interfere with unit operation. In addition, runoff water from roofs, etc... must not be allowed to fall on the outdoor coil; any blockage of airflow through the coil can be detrimental to unit operation and reliability.

The manufacturer suggests that the bottom of the outdoor coil be raised 30cm above grade or roof to prevent possible ice build-up problems.

**The unit frame structure is not designed to be supported by four points (mounting on spring isolators for instance).**

The unit must therefore rest on its whole base.

## Installation

### Unit overall view

**Figure 5 - Indoor section**

#### Embedded control solutions

Trane controller with embedded energy saving functionalities. Centralized control panel for easy access and service. Remote service terminal provided as an option.

#### EC Plug Fan

Compact, quiet and more efficient compared to traditional axial fans. Rail system for easy access and maintenance.

#### Double skin panel

Double wall and thick glass wool insulation provided as standard with all units, for higher indoor air quality.

#### Sloped drain pan

Non-corrosive sloped drain for improved condensate management, thus preventing formation of microbial agents that lead to poor air quality.

#### Epoxy coating

High quality Epoxy coating on fin & tube heat exchanger prevents corrosion and extends unit lifetime

#### Fresh air hood

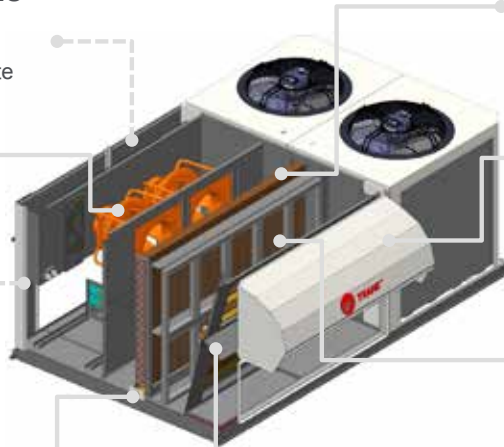
Foldable for easy transportation and installation

#### High Quality Air Filtration

Two rails for wide range of filtration up to F9, capable of meeting local regulations

#### Economizer with intelligent control

Provided as standard with the every Airfinity™ unit, the economizer permits free cooling when conditions are favorable, saving up to 20% on annual energy consumption.



**Figure 6 - Outdoor section**

#### High efficiency scroll compressors in tandem

Delivers high performance in part load thanks to capacity modulation. Capable of meeting future EcoDesign regulations, with SEER up to 3.5.

#### Easy handling

Lifting holes designed to avoid damaging of the unit during transportation. Unit's robust structure also minimizes the need for packaging, reducing on-site waste after installation.

#### Quick adapt

Airfinity units are ideal for replacement jobs thanks to their compatibility with multiple roofcurbs (Trane and non-Trane)

#### Dual refrigeration circuit

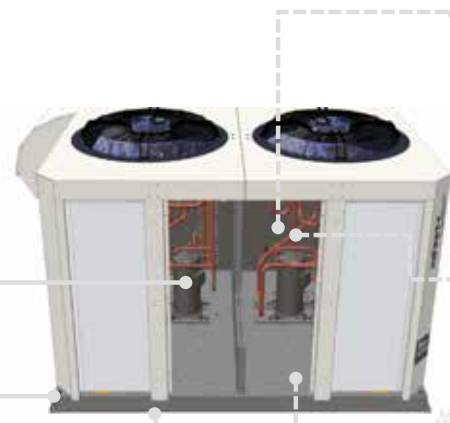
On top of improving capacity modulation and increasing part load efficiency, having two circuits also maximizes reliability by providing system redundancy

#### Electronic Expansion Valve (EEV)

Thanks to its tight control and ability to operate at a lower condensing pressure, the EEV creates additional opportunities for energy savings.

#### Easy-access panels

Can be removed easily using a common turn-key (no screws!). Prevents corrosion and missing components after service.



Protection index of unit is IPX4

## Dimensions/Weights and Clearance

This information is supplied in the document package shipped with the unit.

## Connection of Duct Network

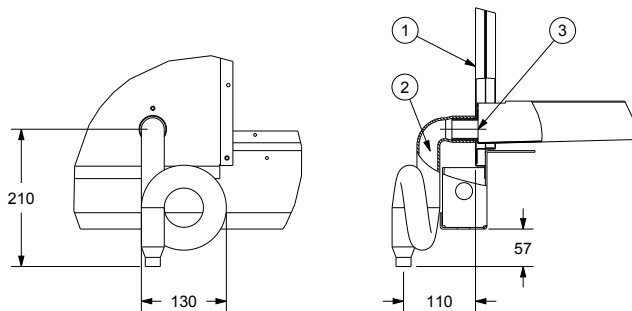
Supply and return openings have curb flanges provided for easy duct installation. It is recommended to insulate the circumference of the curb after the unit is mounted to prevent condensation.

**CAUTION!** All ductwork must be run and attached to the curb flanges before the unit is set into place.

### Guidelines for ductwork construction

- Connections to the unit should be made with 7.5cm canvas connectors to minimize noise and vibration transmission.
- Elbows with turning vanes or splitters recommended to minimize air noise and resistance.
- The first elbow in the ductwork leaving the unit should be no closer than 60cm from the unit, to minimize noise and resistance.

**Figure 7 - Supplied trap**



1. Panel enclosure
2. Atmosphere pressure
3. Static drain

## Attaching horizontal ductwork to unit

- All conditioned air ductwork should be insulated to minimize heating and cooling duct losses. Use minimum of 5cm of insulation with a vapor barrier. The outside ductwork must be weather proofed between the unit and the building.
- When attaching ductwork to a horizontal unit, provide a flexible watertight connection to prevent noise transmission from the unit to the ducts. The flexible connection must be indoors and made out of heavy canvas.

**Note:** Do not draw the canvas taut between the solid ducts.

## Condensate Drain Piping

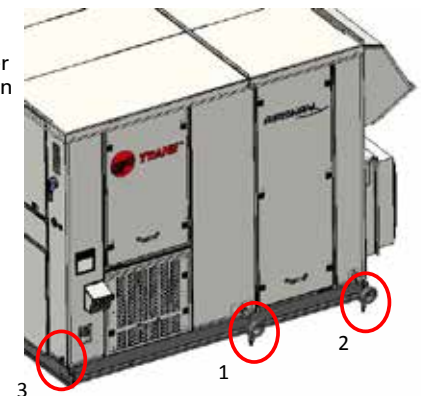
Each unit is equipped with a 1 1/4" female drainage connector. A P trap is supplied and must be connected to the drainage as shown in Figure 7.

Slope the drainage pipe down at least 1% to ensure an adequate condensate flow.

Check all the condensate drainage pipe fittings comply with the applicable construction regulations and waste disposal standards.

**Figure 8 - Drain piping location**

- 1: unit drain pan
- 2: ERC drain pan
- 3: Modulating burner 1/2" drain connection



## Installation

### Filter installation

Access to the filter cells is done via the filter access door. Filter support can be slid laterally.

Each unit is shipped with this available filter combination:

- G4
- G4+F7
- G4+F9
- F5+F7
- F7+F9 combination is not allowed

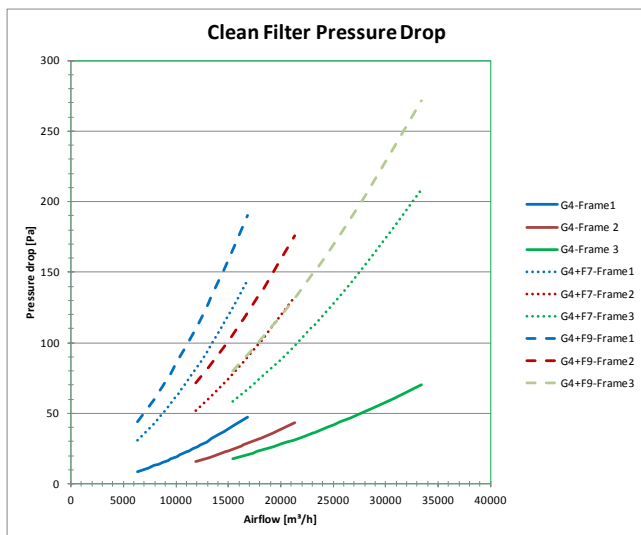
The number and the size of the filter cells are determined by the frame of the unit. Each unit has 2 rails of filter.

per rail

- Frame 1: 6 filters of 500x625
- Frame 2: 8 filters of 500x625
- Frame 3: 12 filters of 500x500

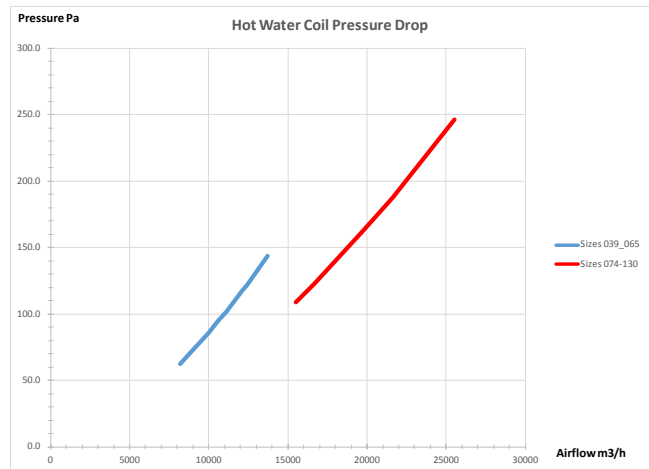
There is 3 different types of filters which are place on rails of 50 mm or 100 mm upstream of the indoor coil.

**Figure 9 - Filter Pressure Drop**

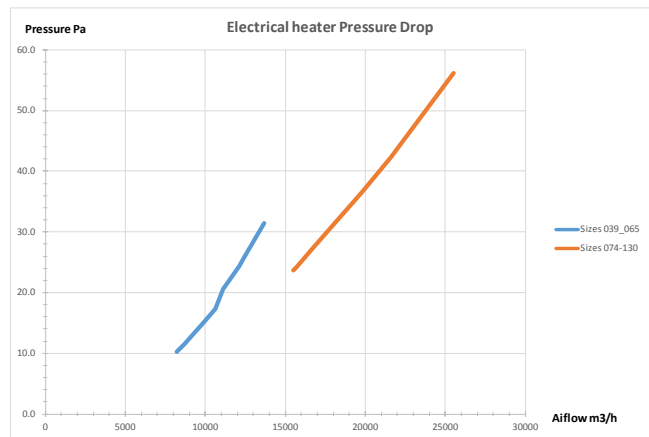


Recommended clog filter switch delta pressure value is 200 Pa with a maximum of 250 Pa according to available static pressure.

**Figure 10 - Hot water coil Pressure Drop**



**Figure 11 - Electrical heater coil Pressure Drop**



### Supply plug fan airflow adjustment

- 1) Order write up (OWU) indicate design airflow, supply and design air pressure drop.
- 2) Verify on site supply fan airflow. It should match OWU design airflow.
- 3) If on site airflow is different from OWU design airflow the actual supply and design air pressure drop should be different from design values, Trane service technician should be mandated to perform air flow adjustment and optimization.

## Installation

### Supply fan Airflow measurement option

The airflow measurement option when selected is associated with an air differential pressure sensor which measures the pressure difference before the inlet nozzle and inside the inlet nozzle.

Unit air flow can be calculated on the basis of the differential pressure (difference in pressure of the static pressures) in keeping with the following equation:

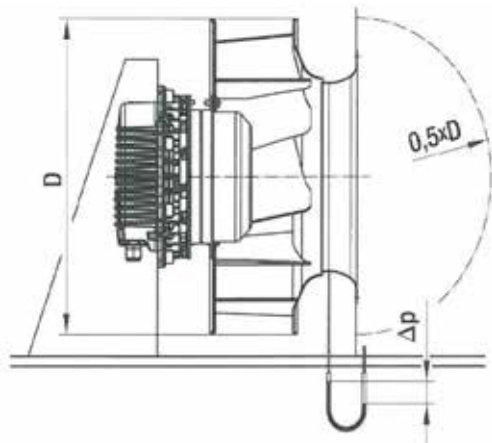
$$Qv = k \cdot \sqrt{\Delta P} \cdot N$$

$Qv$  in [ $m^3/h$ ] and  $\Delta p$  in [Pa]

$N$  number of fans

$k$  takes into account the specific nozzle characteristics.

Connection on the unit side is accomplished via a pre-mounted T tube connector. This tube connector is suited for pneumatic hoses with an internal diameter of 4 mm.



$k$  factors:

Fan diameter	400	450	500
<b>k-factor</b>	188	240	281

According to the option chosen, airflow or fan RPM can be read directly on the optional display or should be determined by connecting a pressure drop meter to the pre mounted T connector.

Setup is -20%/+30% variation versus factory setting (190 $m^3h$ -1/kW @ 250 Pa).

### Gas Pipework Installation

#### Installation of gas piping (to be performed by the contractor)

The installation rules for public buildings shall be followed: refer to the brochure in the "Journal Officiel" number 1477-1 (France only).

The gas supply piping and the gas stop valve shall be dimensioned to guarantee the gas supply pressure at the unit's inlet when it is functioning at full capacity.

It is recommended to install one expansion valve as close as possible to each installed unit. The piping must be self-supporting before the final branch connection to the unit. Allow for a dust trap (filter) upstream of the connection to the unit. Search for gas pipe leaks using tensio-active product such as "Teepol" or "1000 bulles" or another equivalent method. Soapy water must not be used.

#### WARNING!

Never use a flame to search for leaks. The required gas pressures at the unit's inlet connection are specified in table «Marking Category of gas section in different countries»

#### CAUTION!

The piping must not exert any stress on the branch connection to the burner.

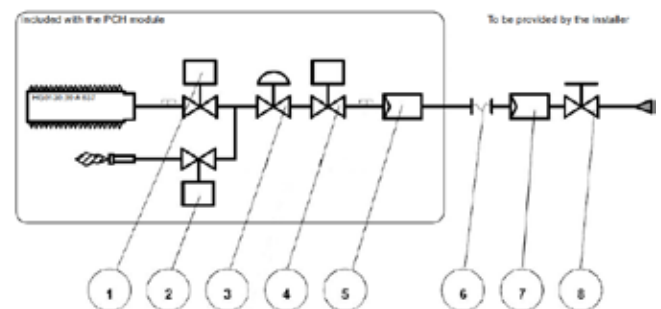
The heating system must be isolated by the gas stop valve on the gas supply piping during the pressure tests, as soon as the pressure exceeds 0.060 bar (60 mbar).

If pressure greater than 0.060 bar is applied to the gas valve inlet the unit may be damaged. In this case it is mandatory to add a pressure reducer.

Connect condensation pipe for modulating burner.

2 stages burner is not supposed produce condensate and the small amount of condensate possibly produced in particular working conditions will in case evaporate

Figure 12 - Typical Gas Supply pipework

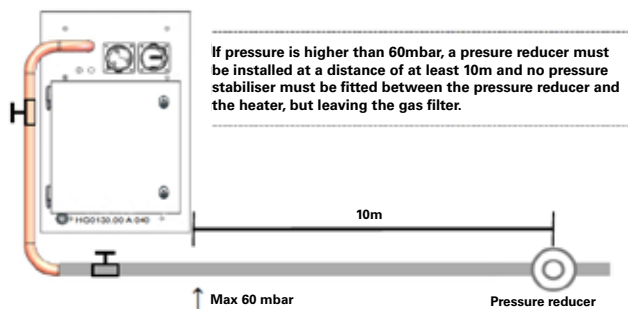


#### KEY

- 1 Main burner gas solenoid valve
- 2 Pilot burner gas solenoid valve
- 3 Pressure stabiliser
- 4 Safety gas solenoid valve
- 5 Gas filter (small section)
- 6 Anti-vibration joint
- 7 Gas filter (large section)
- 8 Gas valve



## Installation



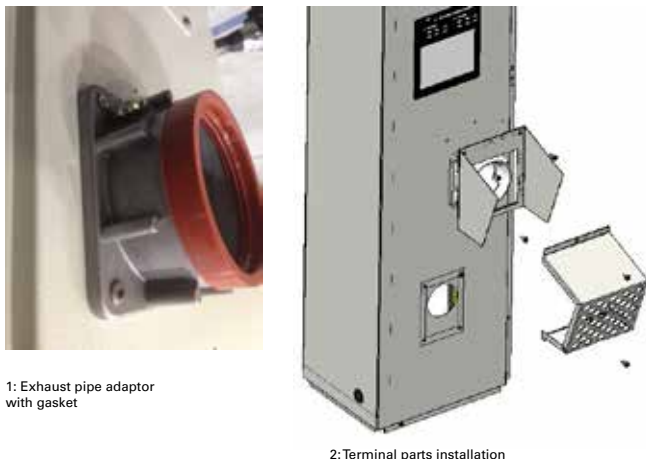
Gas connection Ø : male UNI/ISO 228/1 G3/4" tightening torque 150Nm → all range

### Smoke outlet features

Unit is shipped with an outlet adaptor for connection to exhaust pipe. If there is no exhaust pipe used, a terminal feature located on the accessories should be installed.

**Note: Exhaust pipe material has to be chosen carefully to avoid corrosion.**

Figure 13 - Exhaust gas terminal installation



## General Electrical Recommendations

### Electrical Parts

When reviewing this manual keep in mind.

- All field-installed wiring must be in accordance with local regulations, CE directives and guidelines. Be sure to satisfy proper equipment grounding requirements according CE
- The following standardized values - Maximum Amps - Short Circuit Amps - Starting Amps are displayed on unit nameplate.
- All field-installed wiring must be checked for proper terminations, and for possible shorts or grounds.

**Note:** always refer to wiring diagrams shipped with unit or unit submittal for specific electrical schematic and connection information.

### WARNING Hazardous Voltage!

Disconnect all electric power, including remote disconnects before servicing. Follow proper lockout/tagout procedures to ensure the power can not be inadvertently energized. Failure to disconnect power before servicing could result in death or serious injury.

### Important!

Do not allow conduit to interfere with other components, structural members or equipment. Control voltage (230 V) wiring in conduit must be separate from conduit carrying low voltage (<30V) wiring. To prevent control malfunctions, do not run low voltage wiring (<30V) in conduit with conductors carrying more than 30 volts.

### CAUTION!

Inverters are equipped with integrated filters. They are not compatible with insulated neutral load earthing arrangements.

### WARNING! High voltage!

Any contact with electric components, even after the unit has been switched off, can cause serious injury or death. Wait at least 5 minutes after switching off the unit, until the current dissipates.

## Installer-Supplied Components

Customer wiring interface connections are shown in the electrical schematics and connection diagrams that are shipped with the unit. The installer must provide the following components if not ordered with the unit:

- Power supply wiring (in conduit) for all field-wired connections.
- All control (interconnecting) wiring (in conduit) for field supplied devices.
- Circuit breakers.

### Grounding

Be sure to ground the unit and differential protection should be suited for industrial machinery with current leak which can be higher than 300 mA (several motors and frequency drives).

### CAUTION!

To avoid corrosion, overheating or general damage, at terminal connections of power supply wiring, unit is designed for copper mono-conductors only. In case of multiconductor cable, an intermediate connection box must be added. For cable with alternative material, bi-material connecting devices are mandatory. Cable routing inside control panel should be made case by case by installer.



## Installation

### WARNING Ground Wire!

All field-installed wiring must be completed by qualified personnel. All field-installed wiring must comply with local codes and regulations. Failure to follow this instruction could result in death or serious injury. All power supply wiring must be sized and selected accordingly by the project engineer in accordance with local codes and regulations.

### WARNING!

The Warning Label which is displayed on the equipment and shown on wiring diagrams and schematics. Strict adherence to these warnings must be observed. Failure to do so may result in personal injury or death.

### CAUTION!

Units must not be linked to the neutral wiring of the installation. Units are compatible with the following neutral operating conditions:

TNS	IT	TNC	TT
Standard**	Special	Special	Standard*

\* Differential protection should be suited for industrial machinery with current leak which can be higher than 300 mA (several motors and frequency drives). Neutral wire not distributed.

\*\* Neutral wire not distributed

### Electrical Connections

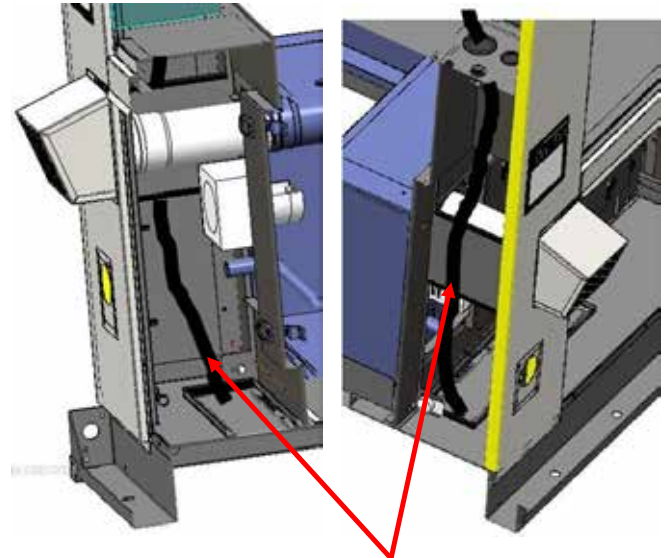
The electric panel is located on the length of the indoor section behind the plug fan section. The unit is designed to run with 400V (+/-10%) - 50 Hz (+/-1%) - 3 ph.

2 glands are available on each unit to be able to connect the unit to the main supply either from the side or from the bottom.

### CAUTION!

Be sure that layout of electrical conduit is remote enough from hot components (burner, electrical heater...).

Figure 14 - Supply Power wiring layout to avoid hot areas



Example of wiring layout of supply power to avoid hot area

**CAUTION!** After completion of wiring, check all electrical connections, and ensure all connections are tight. Replace and secure all electrical box covers and access doors before leaving unit or connecting power to circuit supplying unit.

### Scroll compressors

Proper phasing of the electrical power wiring is critical for proper operation and reliability of the scroll compressor and fans.

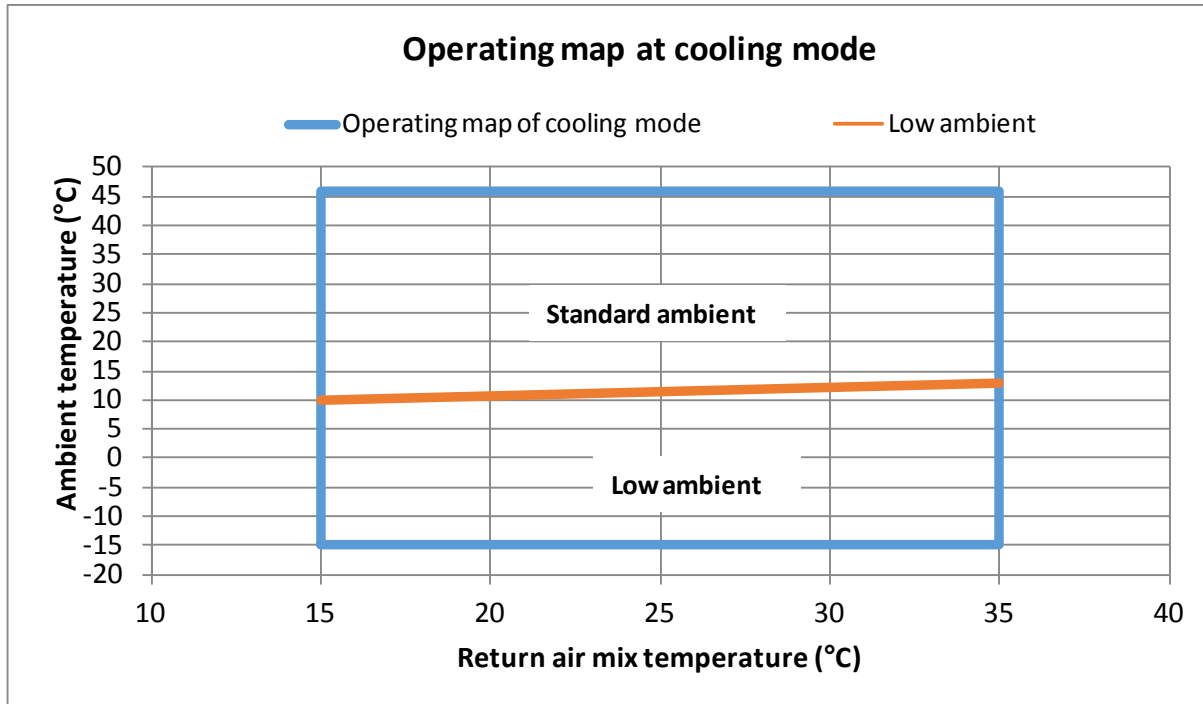
Proper rotation of the scroll compressor must be established before the unit is started. This is accomplished by confirming that the electrical phase sequence of the power supply is correct. The motor is internally connected for clockwise rotation with the inlet power supply phased A, B, C.

The direction of rotation may be reversed by interchanging any two of the line wires. It is this possible interchange of wiring that makes a phase sequence indicator necessary if the operator is to quickly determine the phase rotation of the compressor motor.

The "ABC" indicator on the face of the phase indicator will glow if phase is ABC for terminals L1, L2, and L3.

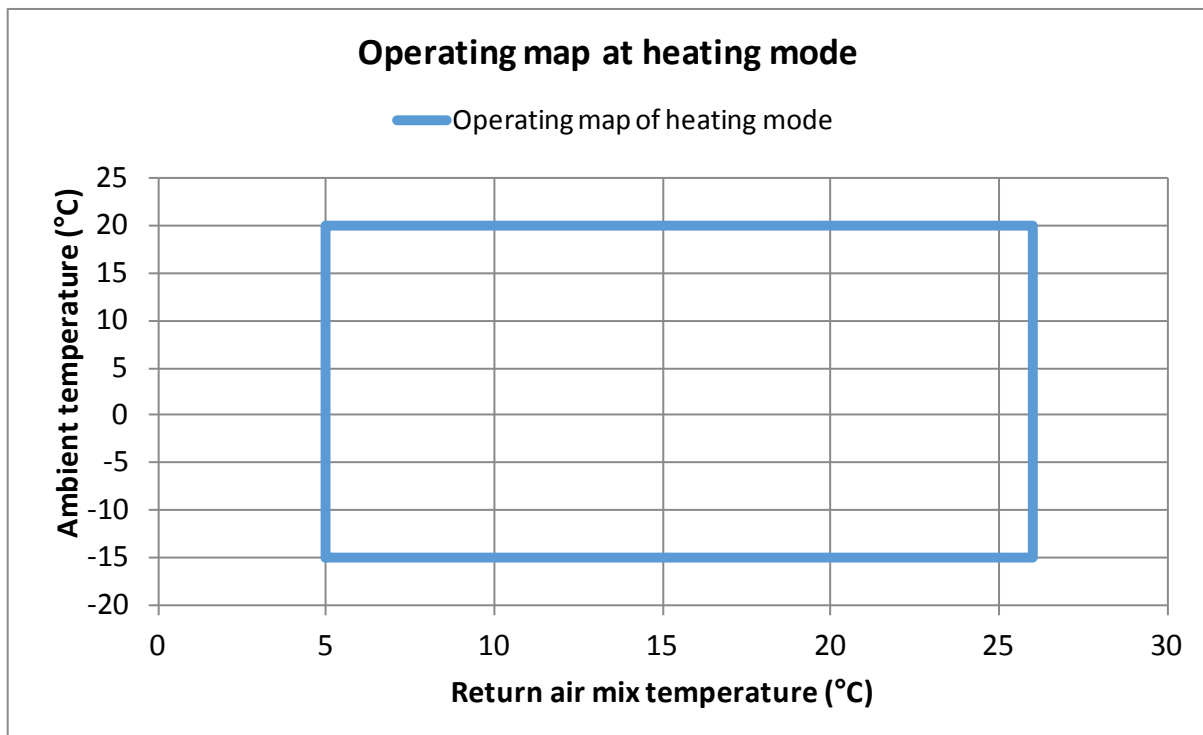
# Operating Map

## Cooling mode

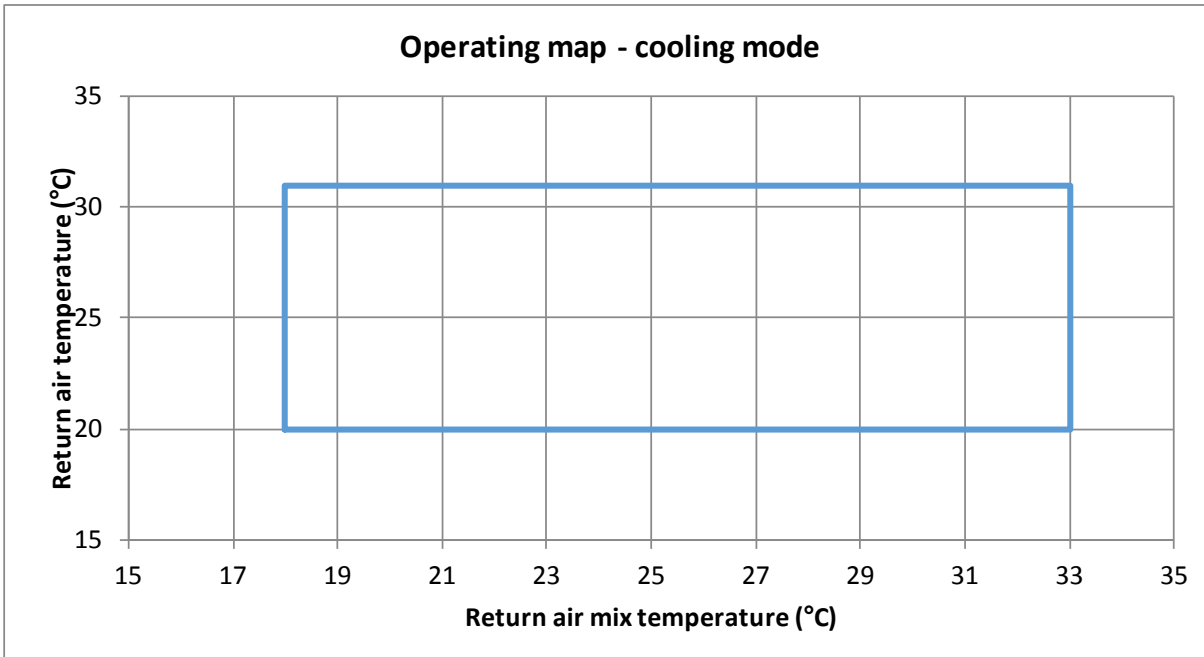


Maximum Outdoor Temperature (@ Eurovent) = 46°C  
 Minimum Outdoor Temperature = -5°C  
 Maximum Indoor Coil Entering Temperature = 35°C  
 Minimum indoor Coil Entering Temperature = 18°C

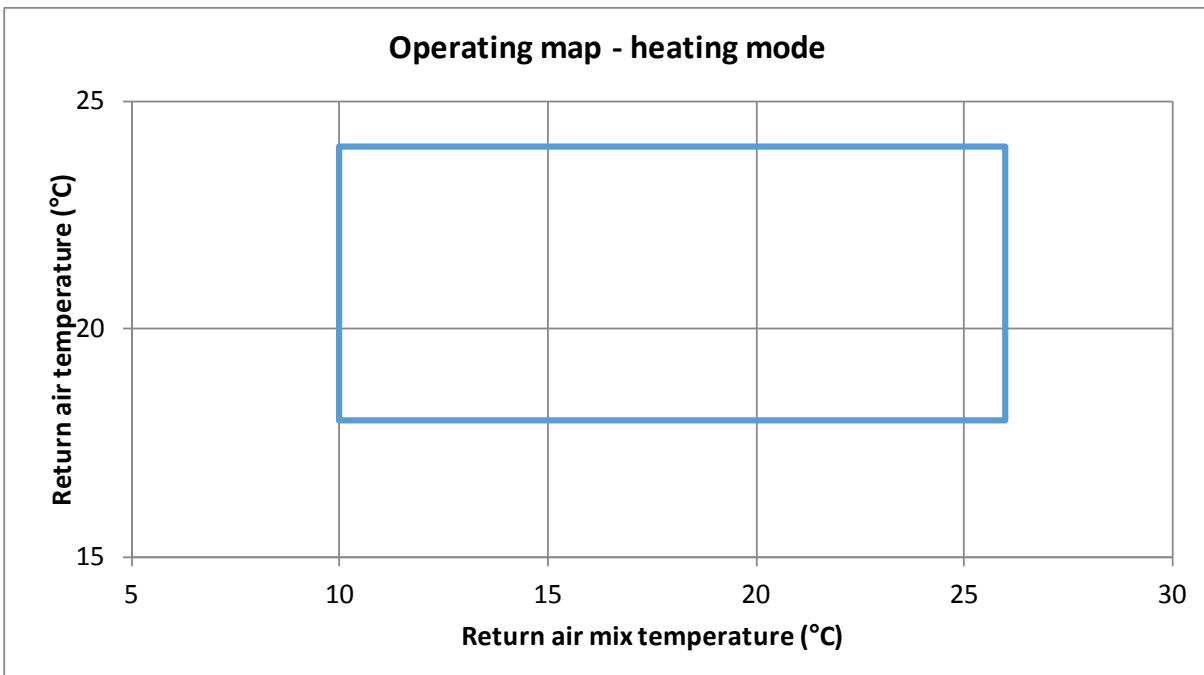
## Heating mode



Maximum Outdoor Temperature (@ Eurovent) = 20°C  
 Minimum Outdoor Temperature = -15°C  
 Maximum Indoor Coil Entering Temperature = 27°C  
 Minimum indoor Coil Entering Temperature = 5°C

**ERC Cooling mode**


Minimum Return Air Mix Temperature = 18°C  
 Maximum Return Air Mix Temperature = 33°C  
 Minimum Return Air Temperature = 20°C  
 Maximum Return Air Temperature = 31°C

**ERC Heating mode**


Minimum Return Air Mix Temperature = 10°C  
 Maximum Return Air Mix Temperature = 26°C  
 Minimum Return Air Temperature = 18°C  
 Maximum Return Air Temperature = 24°C

## Options

Free cooling economizer unit is supplied with economizer and fresh air hood as a standard feature. Fresh air percentage can vary from 0 to 100%.

An economizer consists of:

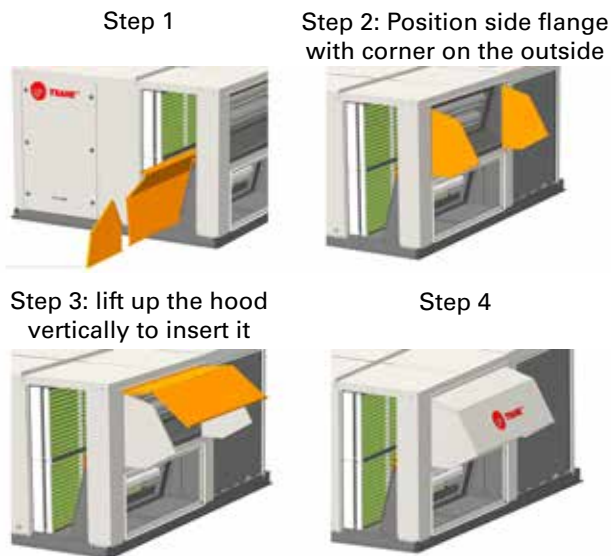
- A motorized damper with separate fresh air and return air sections.
- A fresh air hood with a grill delivered folded in the unit.
- All necessary sensors for free cooling operation.

The mechanical opening of the damper is managed by the actuator which is adjusted by Trane controller.

Damper is activated in free cooling mode and may be further controlled by temperature control with return and outdoor air sensors or by enthalpy control with addition to temperature sensor of return and outdoor humidity sensor.

### Fresh air hood installation

*Figure 12 - Fresh air hood assembly steps*



Caution: In case of ERC, installation of ERC module has to be made prior to fresh air hood.

## Building Pressurization Control

### Barometric Relief

The barometric relief allows to minimize overpressure in the building caused by the introduction of fresh air. This option is typically installed when fresh air intake is below 25% of the nominal air flow and when the return air pressure drop is below 25Pa.

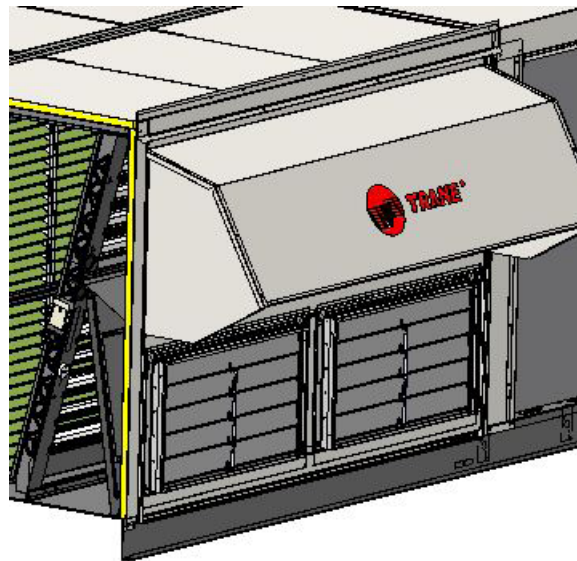
Barometric damper is integrated as standard into economizer option on downflow and not compatible with heat recovery module unit only.

When the pressure of the building increase, the dampers open and relieve air to the outside.

If the return air duct pressure drop is higher than the building overpressure, the dampers will not open.

If the return air duct pressure drop is lower than the building overpressure, the dampers will open and relieve air outside of the building.

*Figure 13 - Barometric relief*



### Exhaust Fans

The exhaust axial fans are used to minimize the overpressure in the building caused by the introduction of fresh air.

This option is typically used when the fresh air intake needed is between 40 to 50% of the nominal air flow or when the return air duct pressure drop is higher than 25Pa (<70Pa or 150Pa according to option selected).

This option includes hoods, gravity dampers and axial fans.

Optional service Terminal allow to adjust exhaust fans start and stop value according to fresh air damper position.

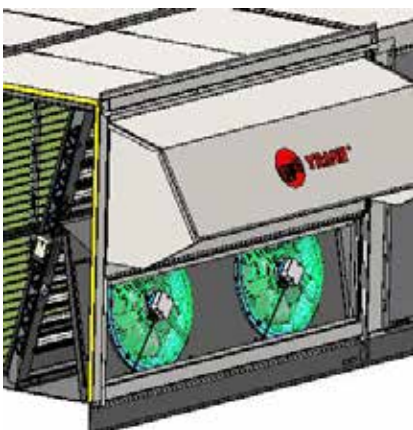
When the supply air fan is ON, the exhaust fans turn on whenever the position of the fresh air dampers meet or exceed the exhaust fan set point. (If the potentiometer is set at 40%, the exhaust fans will start when the fresh air dampers will meet or exceed 40% opening).

#### Operation

- When the exhaust fans are OFF :
  - The barometric dampers open when the air pressure inside the building increases.
  - As the building pressure increases, the pressure in the unit return section also increases, opening the dampers and relieving the air.
  - If return air pressure drop > building overpressure ( $\Delta P > P_b - P_{atm}$ ) → barometric damper is closed.
  - If return air pressure drop < building overpressure ( $\Delta P < P_b - P_{atm}$ ) → barometric damper opens and a maximum of 25% of the nominal airflow can be exhausted.
- When the exhaust fans turn ON :
  - Around 50% of airflow can be exhausted, depending on the pressure drop in the return air duct.
  - The two fans work always together, on stage ON-OFF.
  - Each fan has two speeds, which makes 2 configurable speeds by changing the wiring on site.
  - The exhaust fan is started when fresh air dampers meet or exceed a preset percentage of fresh air.

Configured for Return roofcurb (ESP=250 PA)

**Figure 14 - Exhaust fan**

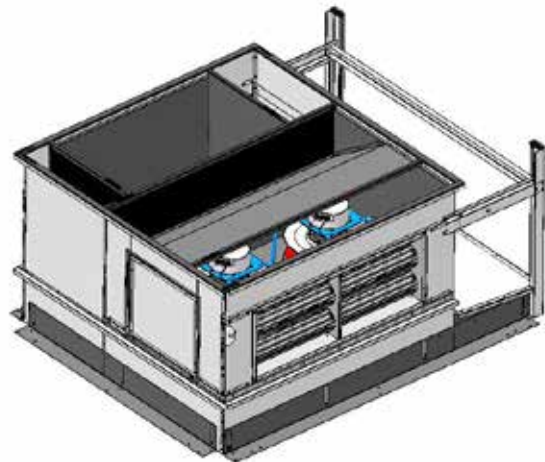


### Configured for Return roofcurb (ESP=250 PA)

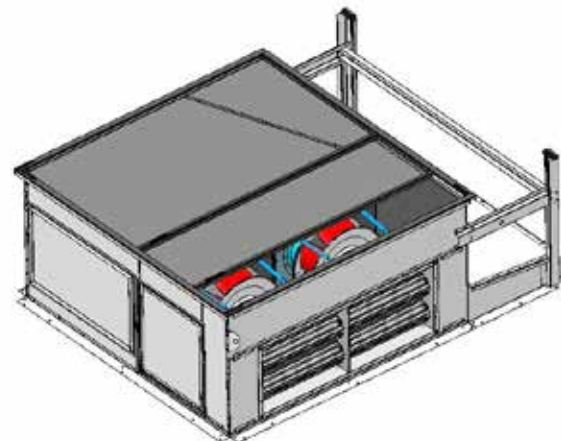
2 types of return roofcurbs modules have been developed (downflow and horizontal flow) in order to minimize overpressure in the building caused by the introduction of fresh air when there is a significant pressure drop in the return duct (250 Pa maximum) and when supply fan is not enough to overcome both supply and return external static pressure.

The module is fully controlled and powered by the rooftop control. The assembly detail is given in the submittal shipped with the document package sent with the unit.

**Figure 15 - Return roofcurb downflow**



**Figure 16 - Return roofcurb horizontal flow**





## Options

### Hot Water Coil (HWC)

Figure 17 - Hot water coil location in the unit



HWC applies when additional heat is required. Hot water comes from external boiler or other device. HWC provides heating with a coil located after the indoor coil and offer full modulation heating control through the use of a 3 ways valve. Control is based on mixed air temperature and zone temperature.

Factory setting is given to heat pump operation. ot water is called in addition. Priority can be switched on site.

Antifreeze protection opens the 3 ways valve when the coil temperature is closed to the freezing point (2°C). In antifreeze mode, unit operating, indoor fan is stopped and unit locked out in manual reset. Fresh air damper is closed and the modulating valves open. The freeze protection works with manual reset.

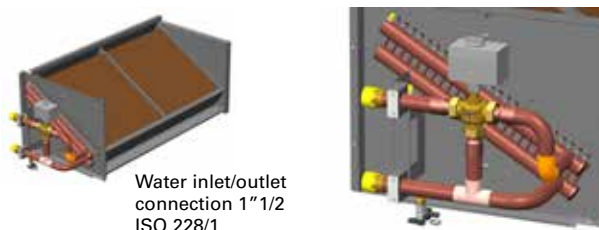
**Important notice: it is important that the pump circulating hot water is permanently working to avoid water to freeze in the coil. Otherwise, in order to prevent water from freezing in the coil during unoccupied period or shutdown limited period, it is recommended to use ethylene glycol. The service of a water treatment specialist is recommended as water used can cause scaling deposits, erosion or corrosion. Insulate and proceed to heater wire installation on all the water piping likely to be exposed to freezing temperatures in order to avoid freeze up of the coil and heat losses. The water distribution network must be fitted with vents in places where air is likely to be trapped.**

Table 1 - Ethylene glycol percentage

Ethylene glycol percentage	Freezing point
(%)	(°C)
10	-4
20	-10

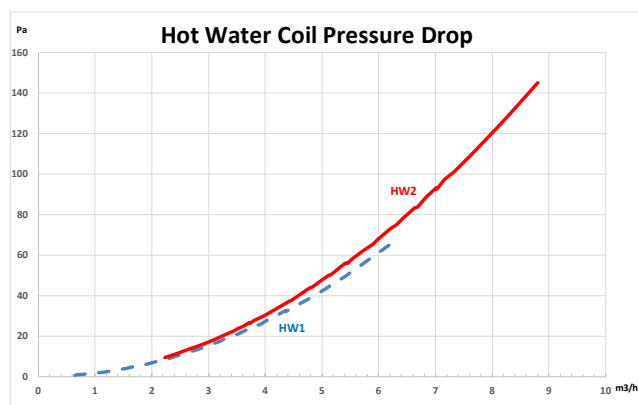
### Water connections dimensions and characteristics

Figure 18 - Hot water coil view and connections



The hot water coil is factory mounted and placed in the discharge section. Two holes are provided to connect the hot water coil. The tubes for entering and leaving water are equipped with a threaded female connection.

Figure 19



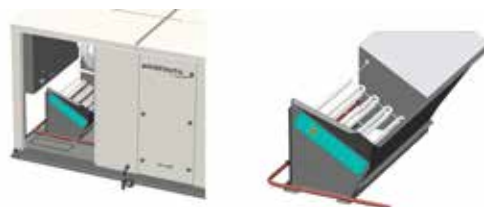
### Electric Heater

Electric heaters are fitted on the supply fan discharge.

Heaters have two heating stages and provided with two types of overheat thermostats:

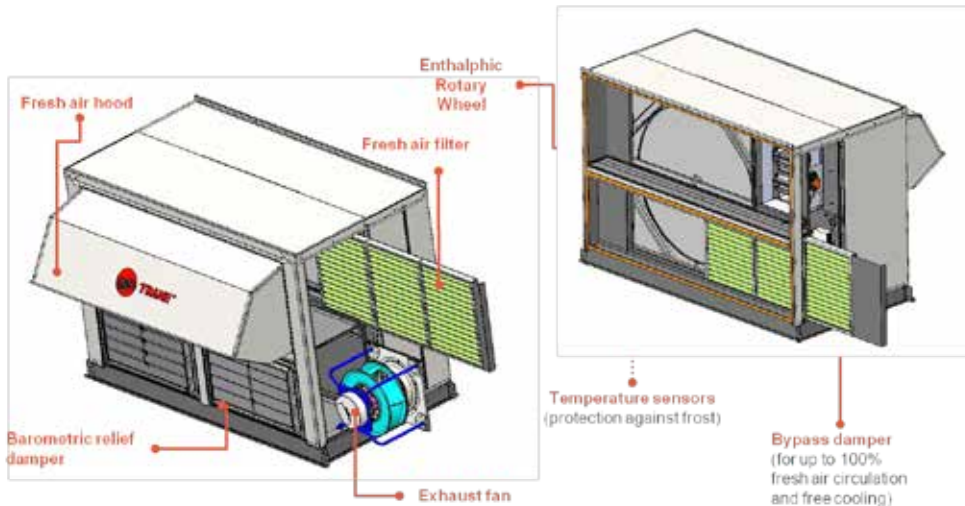
- Automatic reset thermostats which stop the electric heater when the air temperature rises to 65°C. Automatic reset at 32°C.
- The manual reset thermostat which stops the unit when the air temperature rises to 128°C.

Figure 20 - Heater onto unit and heater detail



## Heat Recovery Module

Figure 21

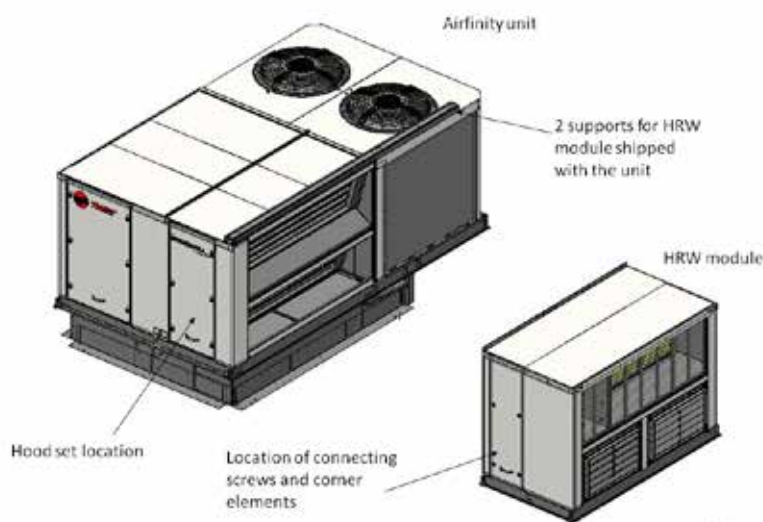


Energy Recovery Module is a module that transfers heat (cool or warm) from exhaust air to fresh air. It is an add-on module that includes a heat exchanger, exhaust fan, filters and dampers, heat exchanger: rotary wheel.

The module is shipped separately and connected to the rooftop on jobsite. The module is fully controlled and powered by the rooftop itself. Free cooling mode is still available.

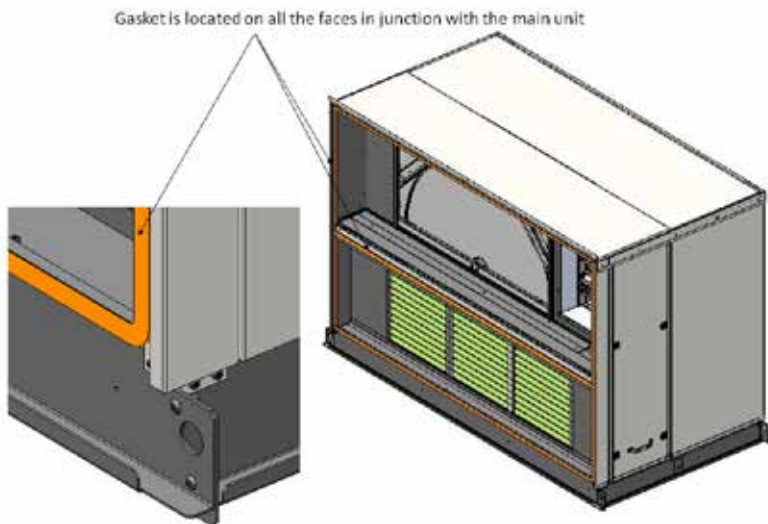
Assembly of the module should be done according to the below instructions and with the help of submittal and electrical drawings shipped with the unit.

Figure 22

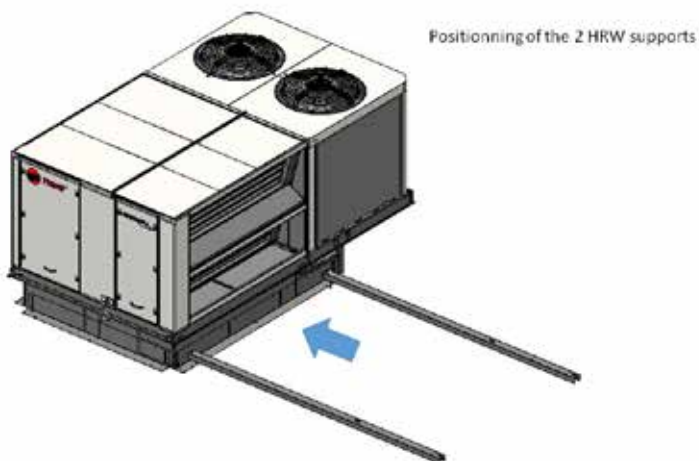


## Options

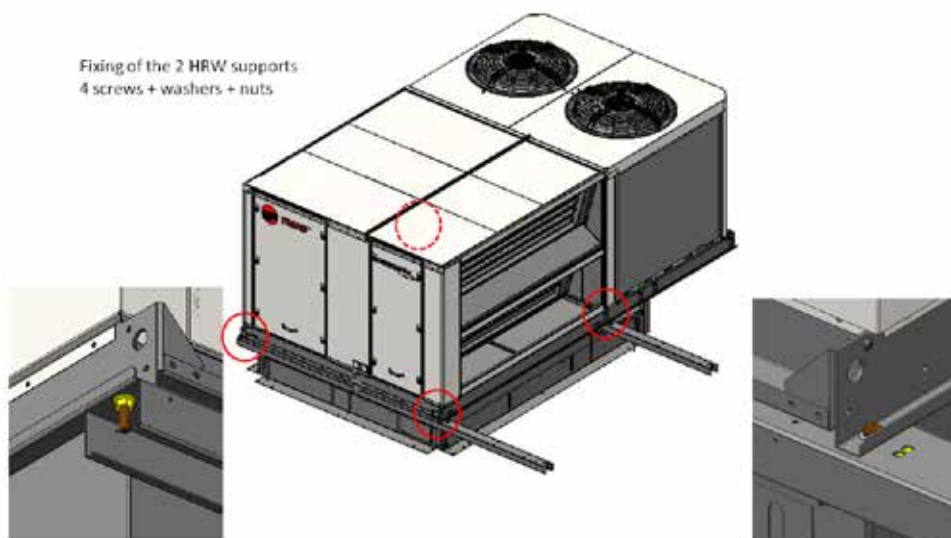
*Figure 23*



*Figure 24*



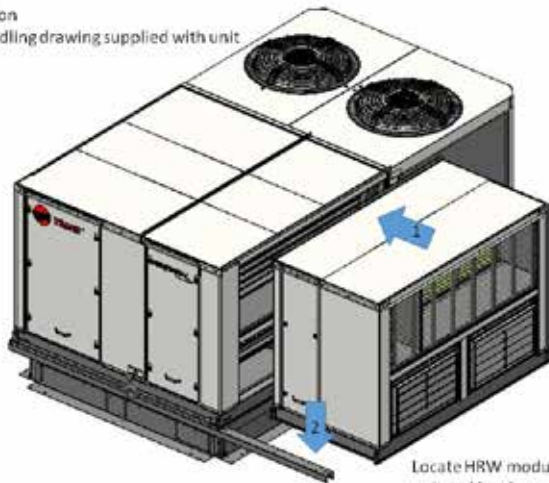
*Figure 25*



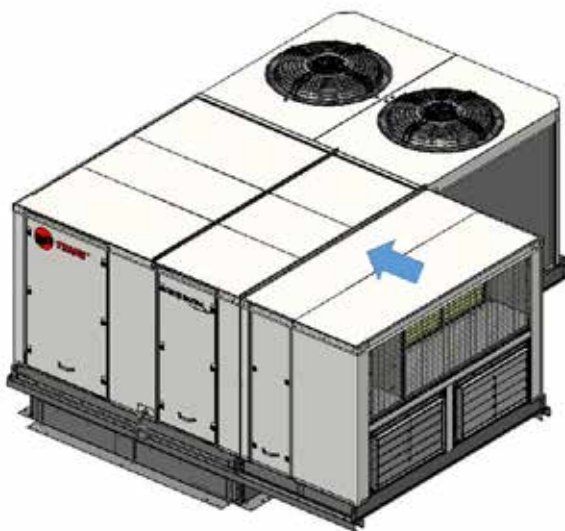


**Figure 26**

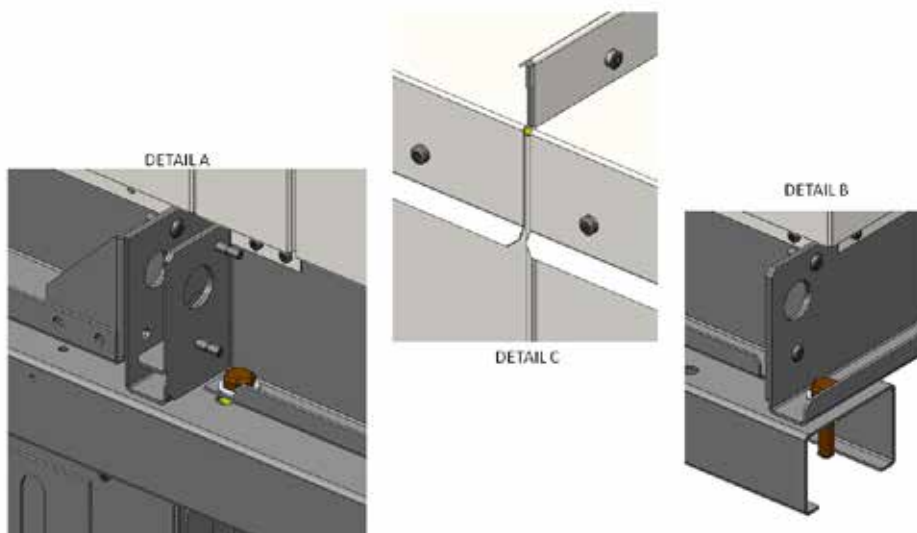
HRW module installation  
For details refer to handling drawing supplied with unit



Locate HRW module to 100 mm of the unit and lay down on the 2 support

**Figure 27**


Make a close contact to the unit to crush the seal. Assemble the HRW module on the 2 support (see details A and B) with screw set and fix the module a the roof level with 4 or 5 tapping screws according to detail C.

**Figure 28**


## Options

Figure 29

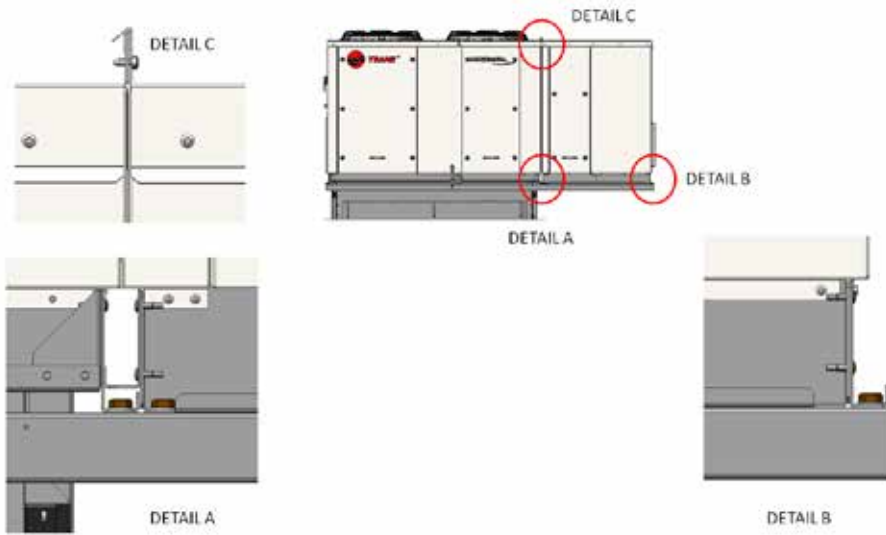
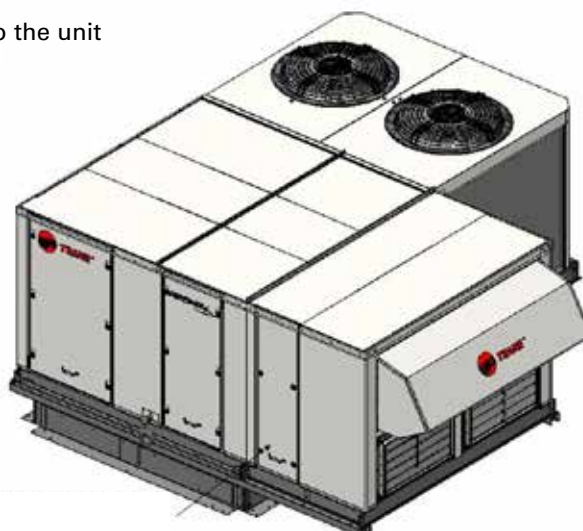
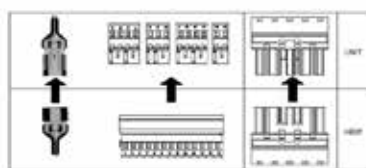


Figure 30



Figure 31

Electrical wiring of ERC module to the unit

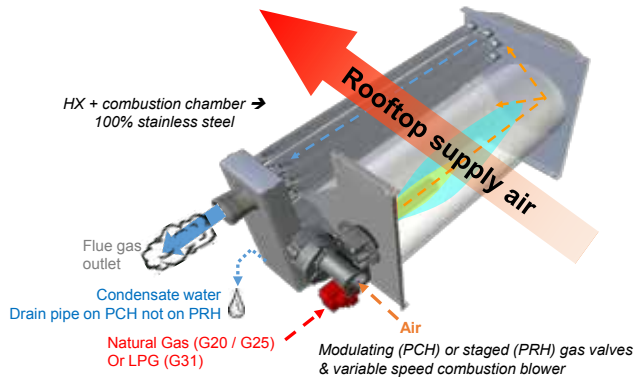


## Burner module

PHR: premix burner with a non condensing heat exchanger

PCH : premix burner with a condensing heat exchanger

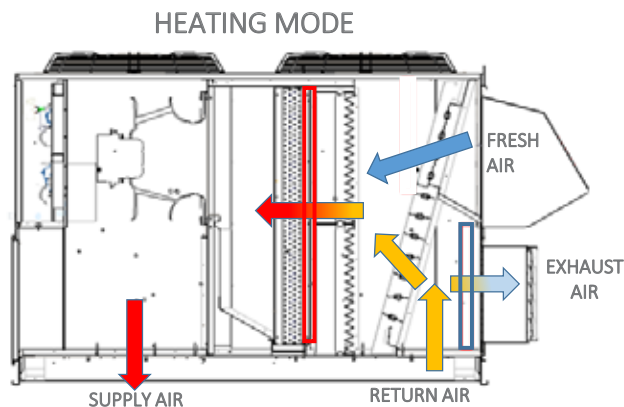
**Figure 32 - Modulating (PCH) or stage (PRH) gas valves and variable speed combustion blower**



## Energy Recovery Circuit (ERC)

The ERC consists of an additional refrigeration circuit which recovers the energy in the exhaust air to pre-heat or pre-cooled the fresh air. The ERC includes a compressor, heat exchanger coils and exhaust fan.

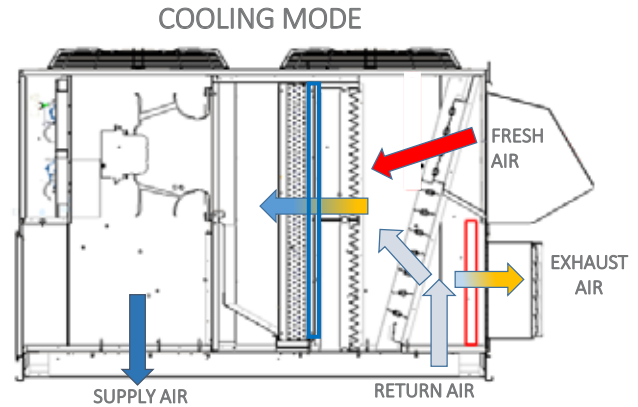
**Figure 33 - Heating mode**



- « Recovery » coil (Condenser)
- « Exhaust » coil (Evaporator)

Hot air coming from the building causes refrigerant evaporation in the "exhaust" coil. Then refrigerant is compressed and conveyed to "Recovery" coil and mix air is preheated through refrigerant condensation in "Recovery" coil.

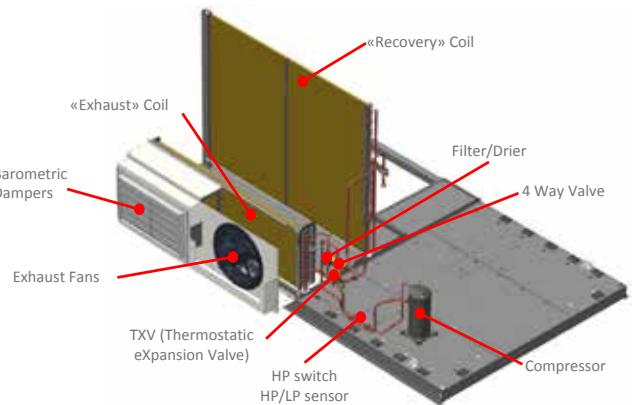
**Figure 34 - Cooling mode**



- « Exhaust » coil (Condenser)
- « Recovery » coil (Evaporator)

Cold air coming from the building causes refrigerant condensation in the "Exhaust" coil, then refrigerant is expanded and conveyed to "Recovery" coil. Mix air is pre-cooled through refrigerant evaporation in "Recovery" coil.

**Figure 35 - Thermodynamic heat recovery**



## Assembly procedure of fan block

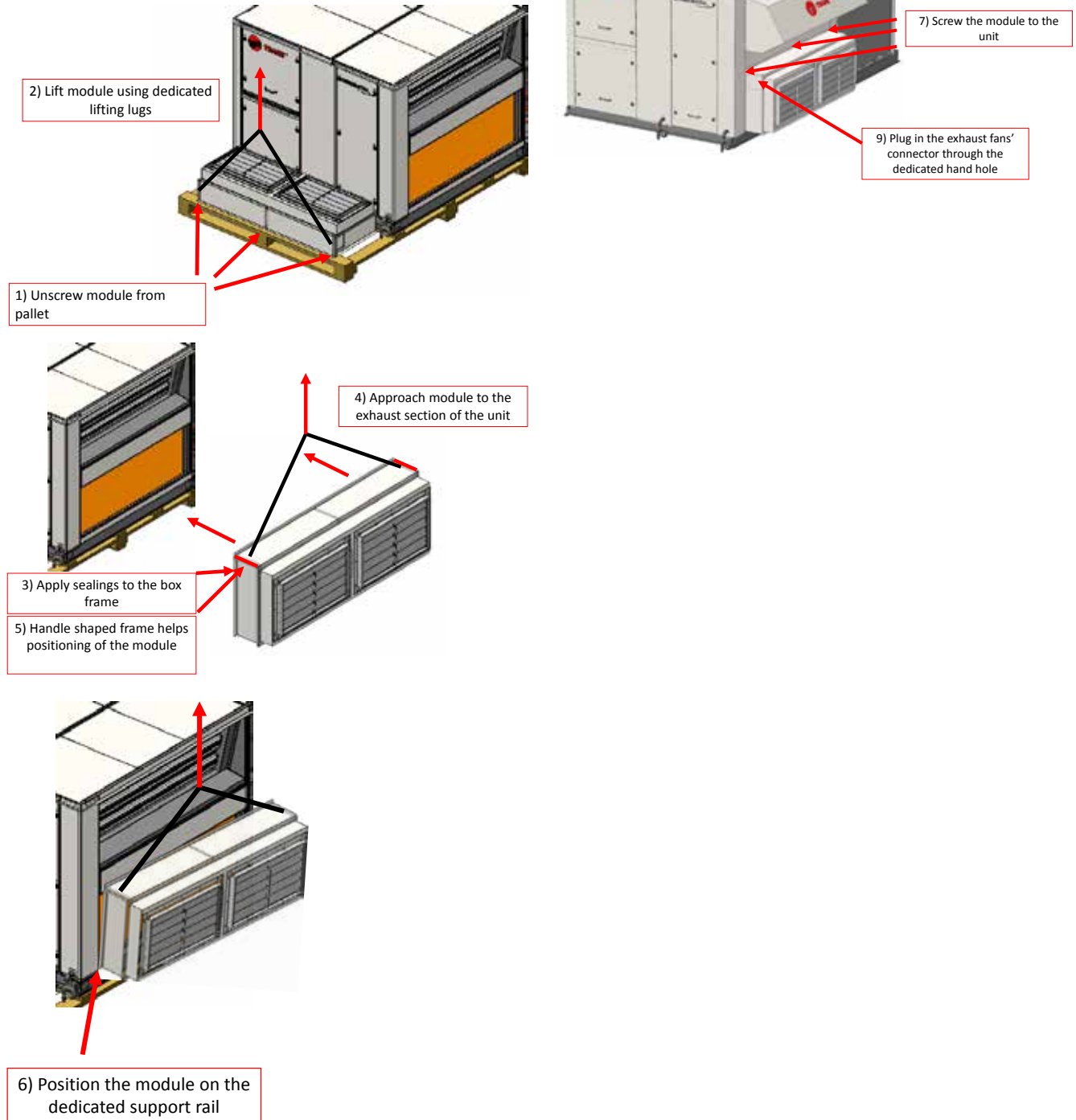
All ERC specific electrical components are located in the electrical box. Electrical connections of exhaust fan must be performed on site.

## Options

### ERC fan module installation

The module is screwed on the main unit pallet

**Figure 36 - ERC Installation process**



## CH536 + module extension

### Control Hardware Modules

The main CH536 module allows the control of the heat pump, the indoor EC fan and the outdoor fan.

3 extension module can be used :

- 1 module for auxiliary heat, economizer enthalpy, exhaust fan and for ERP.
- 1 module for heat recovery.
- 1 extension module to manage customer options.

Figure 37 - CH536 main module



## Service Terminal

The service terminal is an option to the customer, easily plugged to unit through cable. The controller is composed of six different buttons and a graphical display. This view of plug-and-play service and the controller allows personal service to read and modify some parameters of the device as setpoints (cooling and heating), airflow, alarm and warning display.

It includes scrolling menus and explanation of full text.

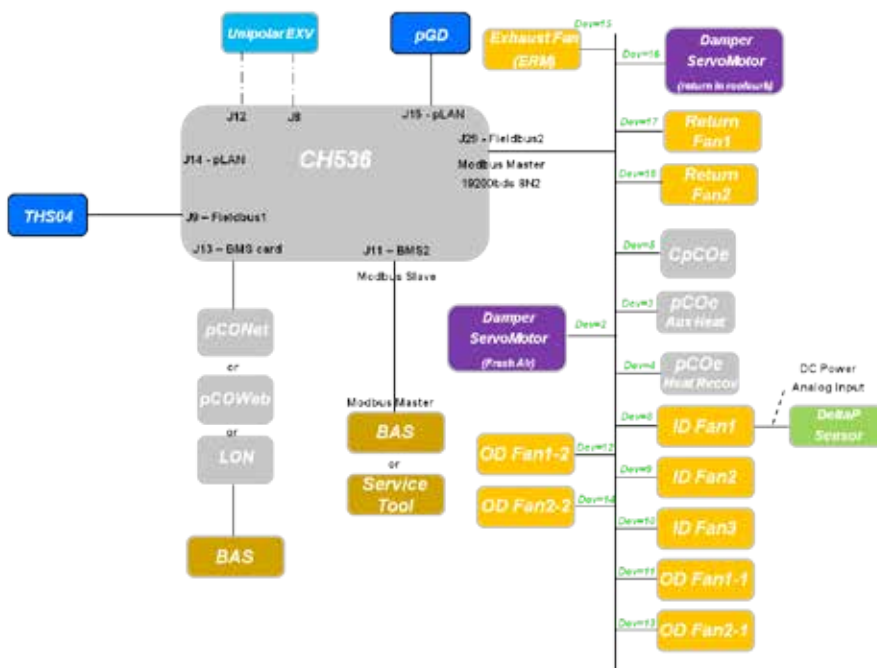
Figure 39 - Optional display



## Control Hardware Bus

This diagram is for information. For details refer to wiring diagram shipped with the unit.

Figure 38 - Control Hardware Bus





## Controls

### Zone temperature source

The zone temperature source are summarized in the table below by hierarchy order.

Source	Condition
1. BAS	BAS command enabled & Value in validity range [-10°C; +50°C]
2. Zone Temp Sensor	Ad-hoc Config enabled & Value in validity range [-10°C; +50°C]
3. Zone Temp THS04	THS04 installed & Ad-hoc Config enabled & Value in validity range [-10°C; +50°C]
4. Conventional Thermostat	Ad-hoc config enabled
4. Return Air Temp	Value in validity range [-10°C; +50°C]

### CO<sub>2</sub> sensor

CO<sub>2</sub> sensor can be either in air return duct or wall mounted. It maintains a CO<sub>2</sub> concentration below a preset value to ensure acceptable comfort.

Controls the opening of the fresh air damper of the economizer. The outside air damper will modulate in order to maintain the CO<sub>2</sub> concentration below the setpoint.

To open damper it should combine the amount of desired fresh air and the free cooling mode to modulate from 0 to 100% maximum opening of the dampers. It is possible to preset a minimum opening during commissioning.

The CO<sub>2</sub> sensor is set for 0-10V analog outputs and provide sensing of carbone dioxide over a range of 0-2000 ppm. The sensor requires a 24 VDC power supply. Consult wiring diagram supplied with the unit for details.

The resolution of analog outputs reaches 10 ppm CO<sub>2</sub>. The information is then sent to the controller CH536 to control the opening position of the fresh air damper.

Avoid locating the duct sensor on surfaces with an uncooled, unheated area behind them or in "dead" spot behind doors or in corners. The CO<sub>2</sub> wall mounted sensor should be placed on a flat surface, 1.4 m from the floor in an area of the room where there is free air circulation.

### CO<sub>2</sub> sensor maintenance

This CO<sub>2</sub> sensor has excellent stability and requires no maintenance. In most environments the recommended calibration interval is five years. A trained service technician can use a portable CO<sub>2</sub> meter to certify sensor calibration. If, when checking the sensor, the reading differs too much from the reference value, the sensor can be recalibrated in the field. A calibration kit, software, and calibration gases are required. If certified accuracy is required, the sensor must be calibrated against accurate and traceable calibration gases in a laboratory. Consult Trane BAS for further details.

### Fire thermostat

U12 is the dedicated I/O. Optional fire thermostat should be configured if present according to wiring diagram.

### Clogged filter detector

This device is mounted in the filter section. The sensor measures the difference in pressure before and after the filter section. The information is sent to the optional service terminal or the BMS.

### Smoke Detector

This device is used to detect smoke in the air stream. It includes a factory mounted detector located in the control panel. When smoke is detected, it shuts off the unit.

### Other accessories available

- DTS : duct mounted wired temperature sensor

The duct mounted sensor - mainly for unit with auxliary heat - must be installed away of any duct singularities and generally at 2 m of any duct elbow or duct inside element both upstream and downstream.

- TZS01 : wall mounted wired temperature sensor

- THS04 : wall mounted thermostat

Refer to separate documentation for more information.

### Alarm and Warnings

Alarms stop the unit or reduce the heating/cooling capacity. Alarm can be either manual reset (requires human intervention to re-start the unit) or automatic reset.

Warning run the unit in fall-back mode.

Example : if outdoor air humidity sensor is not working, the economizer runs in dry-bulb mode.

Events are accessible through optional local service terminal which display the current events and display history of past events (up to 99 alarms and 99 warnings).

# Customer option module

For Customer option module refer to wiring diagram supplied with the unit for detailed information.

## Customer option module

Input/Output are defined with the optional service terminal. Outputs are only with dry contacts.

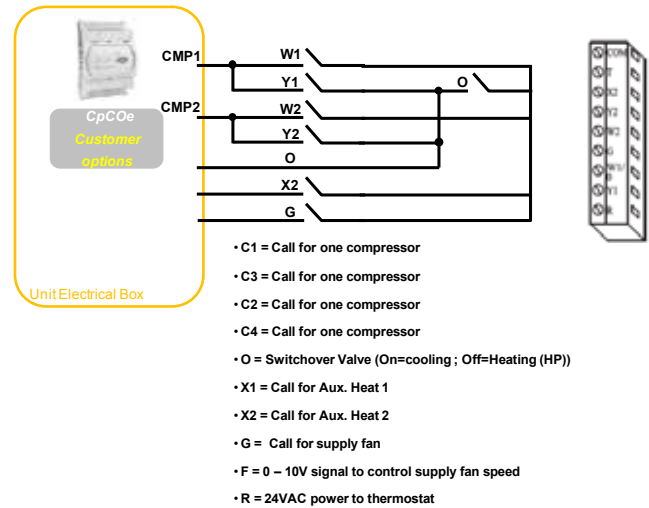
List of I/Os through universal pins

	Emergency Stop	
	External Auto / Off	Takes precedence over THS04
	Circuit1 Disable	
	Circuit2 Disable	
	Compressor 1A Disable	
	Compressor 1B Disable	
	Compressor 2A Disable	
	Compressor 2B Disable	
	Occupancy Sensor	
	Timed Override occupied initiate	
	Timed Override occupied terminate	
	Aux. Heat Disable	
	Mech to Aux Heating changeover	
<b>External Control (Digital In)</b>	Pressurize override	
	Purge override	
	Exhaust override	
	CMP1 *	Conventional Thermostat
	CMP2 *	Conventional Thermostat
	CMP3 *	Conventional Thermostat
	CMP4 *	Conventional Thermostat
	SOV *	Conventional Thermostat
	AuxHeat1 *	Conventional Thermostat
	AuxHeat2 *	Conventional Thermostat
IDFan *	Conventional Thermostat	
	Firestat	

open = OFF / closed = ON

The main module should be configured with the appropriate I/O.

## Operation with a conventional thermostat



For overall wiring, consult wiring diagram supplied with the unit.

Active Unit Mode	Conv Th	O control
OFF	Inactive	-
Auto	Active	enabled
Heat	Active	disabled
Cool	Active	disabled



## Customer option module

### Economizer control

#### Demand Control Ventilation

The 10 I/O for economizer allow 4 strategies for Demand control ventilation

#1: Fixed Ventilation (design ventilation)

It is based on design occupancy of the zone.

Occupied standby setpoint =  $0.6L/s \text{ per } m^2$   
(ASHRAE62.1) x Surface

Occupied setpoint =  $4.72L/s \text{ per person}$   
(ASHRAE62.1) x DesignOccupants# + Occupied  
standby setpoint

#2: Occupancy-based ventilation – requires an occupancy sensor

During occupied hours, depending on occupancy sensor, we can switch between 2 setpoints

no people detected: Occupied Standby Setpoint =  $0.6L/s \text{ per } m^2 \times \text{Surface}$

people detected: Occupied Setpoint =  $4.72L/s \text{ per person} \times \text{DesignOccupants\#} + \text{Occupied Standby Setpoint}$

#3: CO<sub>2</sub>-based ventilation – requires a space CO<sub>2</sub> level information (sensor or BAS)

Modulates between Occupied setpoint and Occupied Standby setpoint with Damper control.

#### Emergency Ventilation override

Three possible external requests, with following priority order

1. Pressurize
2. Purge
3. Exhaust

When those override modes are activated, heating or cooling are turned OFF. If they were ON, the emergency stop mode is used.

Those override modes can be activated through local request or BAS.

Emergency override command:

1. Normal
2. Pressurize
3. Depressurize
4. Purge
5. Shutdown
6. Fire

**Table 2 - Override mode**

Override mode	Pressurize	Purge	Exhaust (Depressurize)	Smoke Detector	Shutdown (Emergency Stop/Firestat)
ID Fan	ON - Full Speed	ON - Full Speed	OFF	OFF	OFF
OA Damper	Open 100%	Open 100%	Close 0%	Open 100%	Close 0%
Exhaust Fan	OFF	ON	ON	OFF	OFF
Heat/Cool	OFF	OFF	OFF	OFF	OFF

### Opening Airflow Damper

The mechanical opening of the damper is managed by the actuator which is adjusted by Trane controller. In Free cooling mode, fresh air flow can be adjusted thru optional terminal but the maximum opening airflow damper minimum position is set at 50% by default and maximum factory setting is 95%. At installation, Minimum Fresh Air Percentage during occupied time have to be adjusted.



# Operation

## Test Procedures

Operating checklist before start-up

- Review submittals for rooftop and accessories as well as main wiring diagrams and options shipped with the unit
- Unit is level, with sufficient clearance all round
- Duct network is correctly sized according to the unit configuration, insulated, and water-tight
- Condensate drainage line is correctly sized, equipped with a trap, and sloped
- Filters are in position, of correct size and quantity and clean
- Wiring is correctly sized and connected in accordance with wiring diagrams
- Power supply lines are protected by recommended fuses and correctly earthed
- Thermostat is correctly wired and positioned
- Unit is checked for refrigerant charge and leaks
- Indoor and outdoor fans rotate freely and are fixed on shafts
- Supply fan rotation speed is set
- Access panels and doors are replaced to prevent air entering and risks of injury

**WARNING!** If any operating checks must be performed with the unit operating, it is the technician's responsibility to recognize any possible hazards and proceed in a safe manner. Failure to do so could result in severe personal injury or death due to electrical shock or contact with moving parts.

### Power-up initialization

**CAUTION!** Before proceeding with any test procedure or operation, make sure that crankcase heaters have been energized for at least 8 hours.

### Starting the unit in cooling mode

Before start-up, ensure that all power cables are tightened.

Verify that the unit airflow rate is adjusted.

## Operating pressures

After the unit has operated in cooling mode for a short period of time, install pressure gauges on the gauge ports of the discharge and suction line valves.

**Note:** Always route refrigerant hoses through the port hole provided and ensure that the compressor access panel is in place.

### Final installation checklist

- Are all power cables tightened?  
**Check torque of power cables contact !**
- Is the condenser fan and indoor blower operating correctly, i.e. correct rotation and without undue noise?
- Are the compressors operating correctly and has the system been checked for leaks?
- Have the voltage and running currents been checked to determine if they are within limits?
- Have the air discharge grilles been adjusted to balance the system?
- Has the ductwork been checked for air leaks and any condensation?
- Has the air temperature rise been checked?
- Has the indoor airflow been checked and adjusted if necessary?
- Has the unit been checked for tubing and sheet metal rattles or any unusual noises?
- Are all covers and panels in place and properly fastened?

To keep the unit operating safely and efficiently, the manufacturer recommends that a qualified service technician check the entire system at least once each year, or more frequently if conditions warrant.

Upon power initialization, the control performs self-diagnostic checks to insure that all internal controls are functioning. It checks the configuration parameters against the components connected to the system.

## Operation

### Gas Burner first start

The PCH & PRH burners are supplied with factory settings according to model number gas selection. They are tested for the gas specified on the burner nameplate.

However it is required to

- Check the gas category
- Check the gas intake pressure on the gas valve
- Perform the combustion analysis to verify that the level of flue gases corresponds to the data contained in general data table or in manufacturer IOM manual.

When turned on for the first time, the pilot burner may not ignite due to air kept in gas hose. There is the need to reset the equipment and repeat the operation until gas hose is purged and it ignites.

Consult electrical drawing and supplier IOM shipped with the unit.

Figure 40 - Example of PCH burner

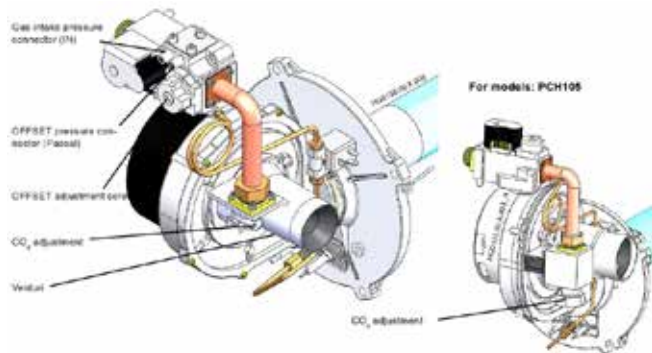


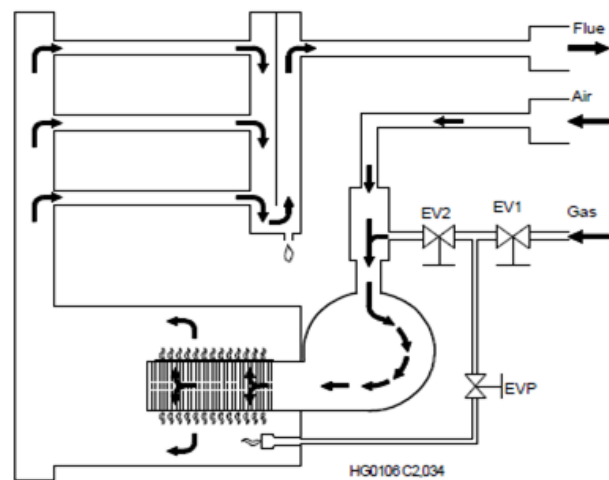
Table 3 - Marking Category of gas section in different countries

CATEGORY	G20	G25	G31
II <sub>2</sub> Esi3P	mbar	FR	
		20	25
II <sub>2</sub> H3B/P	mbar	DK, FI, GR, SE, NO, IT, CZ, EE, LT, SI, AL, MK, BG, RO, HR, TR	
		20	-
II <sub>2</sub> H3B/P	mbar	AT, CH	
		20	-
II <sub>2</sub> HS3B/P	mbar	HU	
		25	-
II <sub>2</sub> L3B/P	mbar	NL	
		-	25
II <sub>2</sub> H3P	mbar	ES, GB, IE, PT, SK	
		20	-
I <sub>2</sub> E( S )	mbar	BE < 70kW	
		20	25
I <sub>2</sub> E( R )	mbar	BE > 70kW	
		20	25
II <sub>2</sub> ELwLs3B/P	mbar	PL	
		20	-
II <sub>2</sub> E3P	mbar	LU	
		20	-
II <sub>2</sub> ELL3B/P	mbar	DE	
		20	20
I <sub>3</sub> P	mbar	BE	
		-	-
I <sub>2</sub> H	mbar	LV	
		20	-

Premix burner working cycle

1. Heat request signal coming from CH536
2. Burner fan starts to pre-wash combustion chamber
3. EV1 and EVP gas valves open to allow gas to feed pilot burner
4. Start up electrode gives ignition sparks on pilot burner
5. EV2 main gas valve opens to gas feed main burner
6. Combustion starts thanks to pilot flame ignition
7. Pilot and main burners work together for a short time, then the electronic boards close EVP and stops the pilot

Figure 41 - Premix burner of working cycle



### Interface panel

PCH

Red 3 digit LCD display

Module status (rdy, On, Off, Fxx...)

3 levels menu:

- I/O (Input/Output)
- PAR (parameters)
- Flt (Faults)



PRH

Green light : power supply

red lights : faults - diagnostics

available by pressing button for more than 5 sec.

Reset button

Summer/winter button



### ERC first start and control

- Check ERC compressor rotation
- Power indoor fans and set to design supply air flow
- Set return roofcurb fans (if present) to design air flow
- Power exhaust fans and check correct rotation.
- In both heating and cooling mode, ERC compressor has priority to start.
- ERC compressor is not authorised to start when indoor air temperature is outside its operating map or fresh air rate is under 20%.
- Outside operating conditions, ERC doesn't start and unit control is as usual
- When ERC becomes available its compressor gets loading priority.

# Maintenance

## End user Routine Maintenance

Some of the periodic maintenance functions for the unit can be undertaken by the end user. This includes replacing (disposable) or cleaning (permanent) air filters, cleaning unit cabinet, cleaning the condenser coil, and carrying out a general unit inspection on a regular basis.

**WARNING!** Disconnect the power supply before removing access panels to service the unit. Failure to disconnect power before attempting any servicing can result in severe injury or death.

### Air filters

It is very important for the central duct system air filters to be kept clean.

These should be inspected at least once a month when the system is in constant operation (in new buildings, the filters should be checked every week for the first four weeks). If disposable-type filters are used, they should only be replaced with ones of the same type and size.

The economizer fresh air filter should be inspected (washed if needed) at least once a month.

**Note:** Do not attempt to clean disposable filters. Permanent filters can be cleaned by washing with a mild detergent and water. Ensure that the filters are thoroughly dry before reinstalling them in the unit (or duct system).

**Note:** Replace permanent filters when required or at least annually if washing fails to clean them, or they show signs of deterioration. Be sure to use the same type and size as were originally installed.

### Condenser coil

Unfiltered air circulates through the unit's condenser coil and can cause the coil's surface to become clogged with dust, dirt, etc. To clean the coil, brush the coil surface in the direction of the fins with a soft bristled brush.

Keep all vegetation away from the condenser coil area.

### Hot water coil (option)

Stop the unit. Do not disconnect the main supply to the unit. This will permit the anti-frost protection to continue to operate, and avoid water to freeze-up in the coil.

## Service Technician Maintenance

**Before the cooling season, your service technician may examine the following areas of your unit:**

- Filters, for cleaning or replacement
- Motors and drives system components
- Economizer gaskets, for replacement if necessary
- Condenser coils, for cleaning
- Safety controls, for mechanical cleaning
- Electrical components and wiring, for replacement and tightening of connections as necessary
- Condensate drain, for cleaning
- Unit duct connections, to ensure they are physically sound and sealed to the unit casing
- Unit mounting support, to ensure that it is sound
- The unit, to ensure there is no obvious deterioration

**Before the heating season, your service technician may examine the following areas of your unit:**

- The unit, to ensure that the condenser coil can receive the required airflow (that the condenser fan grille is not obstructed)
- The control panel wiring, to verify that all electrical connections are tight, and that wire insulation is intact

## Troubleshooting Alarm and Warnings

The optional control display has the ability to provide the service personnel with some unit diagnostics and system status information.

1. Step the system through all of the available modes, and verify operation of all outputs, controls, and modes. If a problem in operation is noted in any mode, proceed to troubleshooting search.
2. Refer to the individual component test procedures if other microelectronic components are suspect.
3. In addition review carefully the components which can lead to the alarm: temperature sensor, zone temperature sensor, clogged filter switch



# Recommended service routine frequencies

As a commitment to our customers, we have created a wide service network staffed with experienced factory authorized technicians. At Trane we offer all the benefits of after sales service direct from the manufacturer and we are committed to our mission statement to provide efficient customer care.

We would be delighted to discuss your individual requirement with you. For further information regarding Trane maintenance agreements please contact your local TRANE sales office.

## RECOMMENDED YEARLY SERVICE ROUTINE FREQUENCIES

Year	Commissioning	500 / 1000 hr Visit	Annual Maintenance	Inspection Visit
1	X	X		XX
2			X	XXX
3			X	XXX
4			X	XXX
5			X	XXX
6			X	XXX
7			X	XXX
8			X	XXX
9			X	XXX
10			X	XXX
+10			Every year	3 Every year

This timetable is applicable to units operating in normal conditions with an average of 4000 hours per year. If operating conditions are abnormally severe, an individual timetable must be made for that unit.

# Maintenance routine

## Commissioning

- Check installation of equipment/pre-commissioning.
- Configure unit control module.
- Calibrate controls.
- Check operational set points and performance.
- Check operation of all safety devices.
- Megger the motor compressor windings.
- Check unit operation.
- Record operating temperatures pressures, amperages and voltage.
- Carry out leak test.
- Fill the start up log sheet and review with the operator.

## Gas Heat

- Check operation of gas train components.
- Check burner sequence of operation.
- Check combustion blower assembly.
- Check gas pressure to unit.
- Inspect flame condition.
- Carry out flue gas analysis.

## Electric Heat

- Inspect all electrical connections.
- Verify correct operation of heating elements.

## Hot Water/Steam

- Inspect valves and traps.
- Verify operation of heating.

## 500/1000 hours visit

- Visit at the end of running in period.
- Replace compressor oil on all circuit's.
- Replace liquid line drier cores on each circuit (if applicable).
- Carry out leak test.
- Inspect contacts and tighten terminals.
- Record operating pressures, amperages and voltage.
- Check condition of evaporator & condenser coils.
- Check operation of machines/compare conditions of operation against original commissioning data.
- Fill out the 500/1000 hours visit log sheet and review with the operator.
- Carry out flue gas analysis ( Gas Heating ).
- Log book to be stamped validating 500/1000hr. visit.

## Inspection visit

- Carry out leak test.
- Inspect contacts and tighten terminals.
- Record operating pressures, amperages and voltage.
- Check condition of evaporator & condenser coils.
- Check operation of machines/compare conditions of operation against original commissioning data.
- Carry out flue gas analysis ( Gas Heating ).
- Complete log sheet and review with the operator.

## Annual Maintenance

- Check operational set points and performance.
- Calibrate controls.
- Check operation of all safety devices.
- Inspect contacts & tighten terminals.
- Megger the motor compressor windings.
- Record operating pressures, amperages and voltage.
- Carry out leak test.
- Check configuration of unit control module.
- Replace line drier cores on each circuit (if applicable).
- Carry out system analysis.
- Change the oil as required based upon results of the Trane laboratory analysis.
- Lubricate motors/dampers/bearings (where applicable).
- Check condition of evaporator & condenser coils.
- Check operation of machines/compare conditions of operation against original commissioning data.
- Complete annual maintenance visit log sheet and review with the operator.

## Gas Heat

- Check operation of gas train components.
- Check burner sequence of operation.
- Check combustion blower assembly clean if required.
- Check gas pressure to unit.
- Inspect flame condition.
- Carry out flue gas analysis.

## Electric Heat

- Inspect all electrical connections.
- Verify correct operation of heating elements.

## Hot Water/Steam

- Inspect valves and traps.
- Verify operation of heating.
- Inspect coil.



## **Additional services**

### **Oil analysis**

Trane Oil Analysis is a predictive tool used to detect minor issues before they become major problems. It also reduces failure detection time and allows planning for appropriate maintenance. Oil changes can be reduced by half resulting in lower operating costs and a lower impact on the environment.

### **Refrigerant analysis**

This Service includes a thorough analysis for contamination and solution upgrade.

It is recommended that this analysis be performed every six months.

### **Trane Select Agreements**

Trane Select Agreements are programs tailored to your needs, your business and your application. They offer four different levels of coverage. From preventive maintenance plans to fully comprehensive solutions, you have the option of selecting the coverage that best suits your requirements.

### **5 years motor-compressor warranty**

This Service will provide a 5 years part and labor warranty for the motor compressor only.

This Service is only available for units covered by a 5 years Maintenance Contract.

### **Energy enhancement**

With Trane Building Advantage you can now explore cost effective ways to optimize the energy efficiency of your existing system and generate immediate savings. Energy management solutions are not only for new systems or buildings. Trane Building Advantage offers solutions designed to unlock energy savings in your existing system.



# Notes



Trane optimizes the performance of homes and buildings around the world. A business of Ingersoll Rand, the leader in creating and sustaining safe, comfortable and energy efficient environments, Trane offers a broad portfolio of advanced controls and HVAC systems, comprehensive building services and parts. For more information visit [www.Trane.com](http://www.Trane.com)