



RAUS air-cooled condensing units

Cooling-only units
Cooling capacity 15.4-41.7 kW



RAUS-PRC001A-GB



Contents

Technical specifications.....	3
Options and accessories	5
Regulations and certifications.....	6
General data.....	7
Performance data.....	8
Operating range.....	9
Electrical data	10
Sound data.....	11
Installation and sizing of refrigerant piping	12
Dimensions and weights	14

Technical specifications

STANDARD CONFIGURATION

The units belonging to RAUS family are air cooled cooling only condensing units for outdoor installation, to be connected to remote evaporating unit.

CASING

Casing made with robust structure in galvanized steel. The powder paint anti-corrosive treatment over the entire frame provides long lasting resistance for outdoor installation, even in aggressive environmental conditions. Easily removable panels providing total access to components inside the unit for service and maintenance purposes.

COMPRESSOR

Compressor of scroll hermetic type. These compressors are featured from high performance with low noise and vibration levels. The high values of COP are obtained:

- By means of high volumetric efficiency in the whole operating range obtained through the continuous contact between the fixed and rotating spirals which avoids the bad space and the re-expansion of the refrigerant;
- By means of low pressure losses due to the absence of suction and discharge valves and to the continuous compression;
- By means of the reduction of the heat exchanging between the suction and discharge refrigerant, thank to the complete separation of the refrigerant paths.

The acoustic features are obtained:

- For the absence of the suction and discharge valves;
- For the continuous and progressive compression process;
- For the absence of pistons which ensures the low vibrations level and pulsation of the refrigerant.

The electric motor is suction cooled and equipped with automatic reset thermal protection and electric heater to prevent the dilution of the refrigerant in the oil during the periods when the unit is stopped. The terminals are contained in a box IP 54 protected.

FANS

Direct drive propeller type fans, protected to IP 54, with statically and dynamically balanced blades. The electric motors are closed type with external rotor, equipped with built-in thermal overload and suitable for outdoor installation. Insulation class F, internal protection according to VDE, suitable for a temperature operating range from -40 to +60°C. All the models are equipped with variable fan speed electronic control with the double advantage to allow the units to work with low outdoor temperature (in cooling mode only) and to considerably reduce the noise level.

REFRIGERANT CIRCUIT

The units are equipped with one refrigerant circuit entirely constructed with copper tubes, each with:

- high pressure switches;
- low pressure switches;
- relief valve on high pressure line.

An optional connection kit is available for the connection to indoor evaporating units. It includes:

- thermostatic expansion valve;
- filter dryer with sight glass;
- liquid line solenoid valve.

Different sizes of liquid receivers are available as options according to specific needs of the plant.

AIR SIDE HEAT EXCHANGER

Condenser coils with seamless copper tubes expanded into aluminum corrugated fins. They are of high efficiency type, complete with sub cooling circuit which allows an increase of cooling capacity without an increase of the power input.

ELECTRICAL PANEL

Electrical control panel made in accordance with CEI 44-5/IEC 204-2 standards, with short circuit current of 10kA, mounted inside the unit, includes:

- safety-locked main switch;
- fuses and contactors for compressor;
- fuses and contactors for the fans;
- fuses 220V auxiliary circuit;
- fuses 24V auxiliary circuit;
- transformer for 24Vac auxiliary circuit power supply;
- low-voltage user terminals board;
- free contacts for the capacity steps activation;
- free contacts for the seasonal switch.

ELECTRONIC CONTROLS

The control of the unit is performed by an electronic card for dynamic parameters control, able to control independently the functionalities and to adjust the operating cycles of the unit.

The controller interface consists of a 2 line LED display and of several icons for quick interaction, interaction with the control is possible with six buttons on the sides of the display.

Through the monitoring system the user can intervene and regulate through the setting of appropriate parameters, the following settings:

- setting the minimum time to re-start a compressor;
- setting the minimum compressor on/off time schedule;
- setting the set point and differential for the management of the card controlling the speed of the connected fans.



Technical specifications

Safety features include:

- high and low pressure switches;
- compressor, fans thermal protection;
- EPROM not correctly connected or not operating correctly self diagnosis;
- probe failure or not connected self diagnosis.

The alphanumeric LED display allows the parameters to be easily entered. Alarms and the functional parameters are displayed immediately.

The control interface provides:

- monitor the analog state variables of the system (pressures on each circuit);
- monitor the state of the compressors, capacity control valves, etc.;
- read the text and the code of the occurred alarm;
- modify operating parameters by inserting the right password;
- defrost timings;
- monitor the analog state variables of the system (pressures on each circuit);
- monitor the state of the compressors, capacity control valves, etc.;
- read the code of the occurred alarm;
- modify the following parameters by inserting the right password:
 - on/off compressors timings;
 - defrost timings (for the heat pumps);
 - condensation control law as a function of the instantaneous high pressure.

There are two types of alarm:

- serious alarms that deactivate the unit, give a text alarm on the display, activate the buzzer and the general alarm output relay fitted. They are:
 - high/low pressure;
 - compressor thermal protection;
 - fans thermal protection;
 - temperature or pressure probe failure;
- signal-only alarms: they only give a signal text on the display and activate the buzzer and the general alarm output relay fitted on the master card. They are:
 - compressor maintenance time over limits.

By contacts (included) in the control panel you can manage the unit in its basic functions in BMS:

- remote on/off selection;
- remote summer/winter selection (for the heat pump versions);
- on/off compressors status.

The electronic controller can be interfaced with a supervision software on a local or remote PC that uses a manufacturer: communication protocol, or with complex BMS systems using ModBus.

Options and accessories

Factory-mounted options

- Compressors sound jackets
- Soft - starter
- Control panel electric heater with thermostat
- Phase failure protection relay
- Epoxy coated condensing coils

Accessories

- Remote control panel
- Communication card RS485
- Connection kit⁽¹⁾
- Liquid receiver
- Service valves on the suction and liquid lines
- Rubber antivibration mounts

⁽¹⁾ Includes: thermostatic expansion valve, filter dryer with sight glass, liquid line solenoid valve.

Regulations and certifications

REFERENCE STANDARDS

THE PRESSURE EQUIPMENT DIRECTIVE (97/23/EC).

UNI EN ISO 3744 ACOUSTIC REGULATION.

UNI-EN-ISO 9001:2008: QUALITY MANAGEMENT SYSTEMS.

LOW VOLTAGE DIRECTIVE (LVD) 2006/95/EC.

MACHINERY DIRECTIVE 2006/42/EC.

DIRECTIVE FOR ELECTROMAGNETIC COMPATIBILITY 2004/108/CE.

CEI-EN 60204-1 DIRECTIVE (CEI44-5; CEI EN 62061)

MACHINERY SAFETY – ELECTRIC MACHINERY – EQUIPMENTS.

ERP DIRECTIVE (ENERGY-RELATED-PRODUCTS ECODESIGN 2009/125/CE).

UNI EN 14511-1-2-3-4 TESTING CONDITIONS.

CERTIFICATIONS

PED RELEASED FROM IMQ SPA - NOTIFIED BODY FOR REGULATION 97/23/EC (NO. 0051) ACCORDING TO THE FOLLOWING STATEMENTS:

- DECLARATION OF QUALITY SYSTEM APPROVAL - FORM H1 (QUALITY ASSURANCE WITH DESIGN CONTROL AND MONITORING OF FINAL CHECK DETAIL): CERTIFICATE N. PEC-0051-1105003.
- CERTIFICATES OF EXAMINATION OF THE PROJECT N. 0051-PEC-1105004/05/06/07/08.

QUALITY CERTIFICATION ACCORDING TO THE STANDARD UNI EN ISO 9001:2008 ISSUED BY CSQ (ACCREDITED BY ACCREDIA).

PERFORMANCE CERTIFICATION OF THE UNIT WITH THE PRESENCE OF RINA SPA DURING THE TESTING PROCESS (OPTIONAL).

GOST CERTIFICATION - (OPTIONAL) FOR PRESSURE RECIPIENTS OF THE RUSSIAN FEDERATION.

General data

Unit size		040	060	070	080	100	110
Total capacity	kW	15,4	21,2	24,5	28,6	37,2	41,7
Compressors power input	kW	4,6	6,6	8,1	8,6	10,9	12,9
Total EER		3,17	2,96	2,83	2,93	3,07	2,95
COMPRESSORS							
Number of compressors	n	1	1	1	1	1	1
Refrigerant circuits	n	1	1	1	1	1	1
Part load	n	1	1	1	1	1	1
Refrigerant charge	kg	4,3	4,9	5,1	5,3	6,6	9,4
Oil charge	kg	1,8	3,3	3,3	3,3	6,2	6,2
FANS							
Fans number	n	2	1	1	2	2	2
Air flow	m ³ /h	5770	7768	7768	15950	14819	14819
Power input for each fan	kW	0,13	0,60	0,60	0,60	0,60	0,60
Absorbed current for each fan	A	0,59	2,62	2,62	2,62	2,62	2,62
SOUND LEVEL							
Sound power level (ISO 3744)	dB(A)	75,5	72,0	73,0	74,0	74,5	81,0
Sound pressure level at 5 m (ISO 3744)	dB(A)	49,5	45,9	46,9	47,8	48,3	54,8
Sound pressure level at 10 m (ISO 3744)	dB(A)	44,1	40,5	41,5	42,4	42,9	49,4
DIMENSIONS AND WEIGHT							
Length	mm	1125	1465	1465	1671	1671	1671
Depth	mm	440	560	560	560	560	560
Height	mm	1444	1448	1448	1687	1687	1687
Weight	kg	151	221	230	259	262	272

Cooling: Outdoor air temperature 35°C; Evaporating temperature 5°C.

Sound pressure levels refer to summer period.

Performance data

COOLING CAPACITY

Te			040						060					
			Outdoor air temperature						Outdoor air temperature					
			25	30	32	35	40	43	25	30	32	35	40	43
2	Pf	kW	15,7	14,8	14,4	13,8	12,7	12,0	21,6	20,3	19,8	19,0	17,6	16,7
	Pa	kW	3,7	4,1	4,3	4,6	5,1	5,5	5,4	5,9	6,2	6,5	7,2	7,7
3	Pf	kW	16,3	15,3	14,9	14,3	13,2	12,5	22,4	21,1	20,5	19,7	18,3	17,4
	Pa	kW	3,7	4,1	4,3	4,6	5,1	5,5	5,4	5,9	6,2	6,5	7,2	7,7
4	Pf	kW	16,9	15,9	15,5	14,8	13,7	13,0	23,2	21,8	21,3	20,4	19,0	18,0
	Pa	kW	3,7	4,1	4,3	4,6	5,1	5,5	5,4	5,9	6,2	6,5	7,2	7,7
5	Pf	kW	17,5	16,5	16,0	15,4	14,3	13,6	24,0	22,6	22,1	21,2	19,7	18,7
	Pa	kW	3,7	4,1	4,3	4,6	5,1	5,5	5,4	6,0	6,2	6,6	7,2	7,7
6	Pf	kW	18,1	17,0	16,6	16,0	14,8	14,1	24,9	23,5	22,9	21,9	20,4	19,4
	Pa	kW	3,7	4,1	4,3	4,6	5,1	5,5	5,4	6,0	6,2	6,6	7,3	7,7
7	Pf	kW	18,7	17,6	17,2	16,5	15,4	14,6	25,8	24,3	23,7	22,7	21,2	20,1
	Pa	kW	3,7	4,1	4,3	4,6	5,1	5,5	5,4	6,0	6,2	6,6	7,3	7,7

Te			070						080					
			Outdoor air temperature						Outdoor air temperature					
			25	30	32	35	40	43	25	30	32	35	40	43
2	Pf	kW	25,1	23,6	22,9	22,0	20,3	19,2	29,2	27,5	26,7	25,7	23,8	22,6
	Pa	kW	6,6	7,3	7,5	8,0	8,9	9,4	7,0	7,7	8,0	8,5	9,4	10,0
3	Pf	kW	26,1	24,5	23,8	22,8	21,0	19,9	30,2	28,5	27,8	26,6	24,7	23,5
	Pa	kW	6,6	7,3	7,6	8,0	8,9	9,4	7,0	7,7	8,0	8,5	9,4	10,0
4	Pf	kW	27,0	25,4	24,7	23,6	21,8	20,7	31,3	29,5	28,8	27,6	25,6	24,4
	Pa	kW	6,6	7,3	7,6	8,0	8,9	9,5	7,0	7,7	8,1	8,5	9,4	10,0
5	Pf	kW	28,0	26,3	25,6	24,5	22,7	21,5	32,5	30,6	29,8	28,6	26,6	25,3
	Pa	kW	6,6	7,3	7,6	8,1	8,9	9,5	7,1	7,8	8,1	8,6	9,5	10,1
6	Pf	kW	29,0	27,3	26,5	25,4	23,5	22,3	33,7	31,7	30,9	29,7	27,6	26,2
	Pa	kW	6,6	7,3	7,6	8,1	8,9	9,5	7,1	7,8	8,1	8,6	9,5	10,1
7	Pf	kW	30,1	28,2	27,5	26,4	24,4	23,1	34,9	32,9	32,0	30,8	28,6	27,2
	Pa	kW	6,6	7,3	7,6	8,1	8,9	9,5	7,1	7,8	8,1	8,6	9,5	10,1

Te			100						110					
			Outdoor air temperature						Outdoor air temperature					
			25	30	32	35	40	43	25	30	32	35	40	43
2	Pf	kW	37,9	35,7	34,8	33,4	30,9	29,3	42,5	40,1	39,0	37,5	34,7	33,0
	Pa	kW	8,9	9,8	10,2	10,9	12,2	13,0	10,7	11,7	12,1	12,8	14,1	15,0
3	Pf	kW	39,3	37,1	36,1	34,6	32,1	30,5	44,1	41,5	40,5	38,8	36,0	34,2
	Pa	kW	8,9	9,8	10,2	10,9	12,2	13,0	10,7	11,7	12,1	12,8	14,1	15,0
4	Pf	kW	40,7	38,4	37,4	35,9	33,3	31,6	45,7	43,0	41,9	40,2	37,3	35,5
	Pa	kW	8,9	9,8	10,3	10,9	12,1	13,0	10,7	11,7	12,2	12,9	14,2	15,0
5	Pf	kW	42,2	39,8	38,8	37,2	34,5	32,8	47,3	44,6	43,4	41,7	38,7	36,8
	Pa	kW	8,9	9,8	10,3	10,9	12,1	13,0	10,8	11,8	12,2	12,9	14,2	15,1
6	Pf	kW	43,7	41,2	40,2	38,6	35,8	34,0	48,9	46,1	44,9	43,1	40,1	38,1
	Pa	kW	8,9	9,9	10,3	10,9	12,1	13,0	10,8	11,8	12,2	12,9	14,2	15,1
7	Pf	kW	45,2	42,7	41,6	40,0	37,1	35,3	50,6	47,7	46,5	44,7	41,5	39,5
	Pa	kW	8,9	9,9	10,3	10,9	12,2	13,0	10,8	11,8	12,3	13,0	14,3	15,1

Te = Evaporating temperature (°C)

Pf = Cooling capacity (kW)

Pa = Compressors power input (kW)

Operating range

Operating range

Operating mode	Ta		Te	
	Min	Max	Min	Max
Cooling	5	43	-12	12

Ta = Outdoor air temperature (°C)

Te = Evaporating temperature (°C)

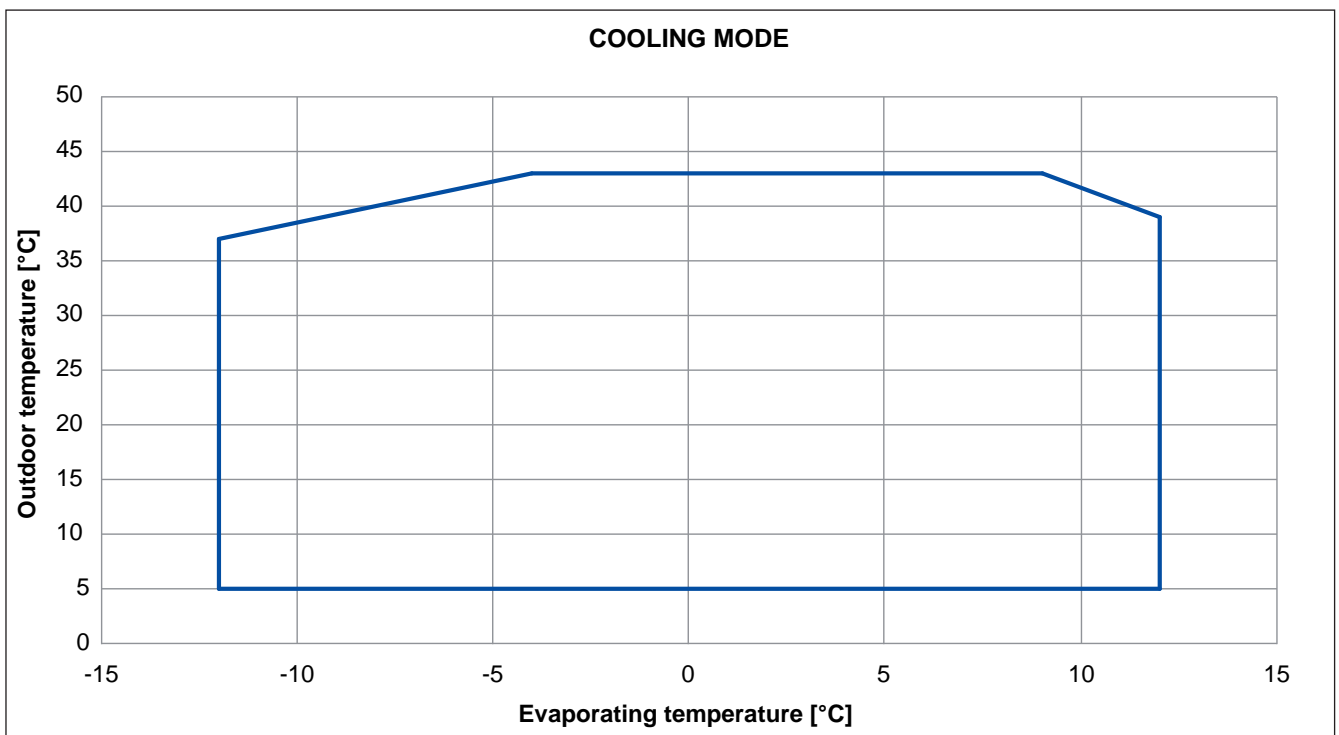

Electrical data

Unit size	NOMINAL VALUES Outdoor air temperature 35°C, evaporator water temperature in/out 12/7°C									MAXIMUM VALUES (1)		
	Compressors (2)			Fans		TOTAL			TOTAL			
	F.L.I.	F.L.A.	L.R.A.	E.P.	O.C.	F.L.I.	F.L.A.	S.A.	F.L.I.	F.L.A.	S.A.	
	kW	A	A	kW	A	kW	A	A	kW	A	A	
040	4,6	8,3	71,0	0,3	1,2	4,8	9,5	72,2	5,4	10,2	72,2	
060	6,6	12,1	98,0	0,6	2,6	7,2	14,7	100,6	13,2	24,6	100,6	
070	8,1	14,6	142,0	0,6	2,6	8,7	17,2	144,6	14,9	27,6	144,6	
080	8,6	15,9	142,0	1,2	5,2	9,8	21,1	147,2	17,8	34,2	147,2	
100	10,9	19,1	158,0	1,2	5,2	12,1	24,3	163,2	21,2	40,2	163,2	
110	12,9	23,4	197,0	1,2	5,2	14,1	28,6	202,2	21,8	41,2	202,2	

Electrical data referred to 400V - 3PH+N-50Hz: Maximum operating admitted conditions: 10%; Maximum phase unbalance: 3%.

FLI Full load power input at the conditions of the selection.

FLA Full load current at the conditions of the selection.

SA Inrush current (sum of LRA of the biggest compressor, current of the other compressors, total current of the fans).

LRA Locked rotor amperes for the biggest compressor.

FLI_{max} Full load power input at the worst conditions for compressors and fans (at the limit of the unit envelope).

FLA_{max} Full load current at the worst conditions for compressors and fans (at the limit of the unit envelope).

Samax Inrush current (sum of LRA of the biggest compressor, current of the other compressors calculated at the worst conditions, total current of the fans).

(1) maximum operating admitted conditions by the compressors manufacturer.

(2) data referred to biggest compressor for units with different compressors.

Sound data

Standard unit

Unit size	Octave bands (Hz)								Lw dB(A)
	63	125	250	500	1000	2000	4000	8000	
	Sound pressure level (dB)								
040	53,4	49,4	44,8	40,6	38,2	53,4	35,9	24,9	75,5
060	49,9	45,9	41,3	37,1	34,7	49,9	32,4	21,4	72,0
070	50,9	46,9	42,3	38,1	35,7	50,9	33,4	22,4	73,0
080	51,8	47,8	43,2	39,0	36,6	51,8	34,3	23,3	74,0
100	52,3	48,3	43,7	39,5	37,1	52,3	34,8	23,8	74,5
110	58,8	54,8	50,2	46,0	43,6	58,8	41,3	30,3	81,0

The following table refers to units equipped with compressors sound jackets (optional)

Unit size	Octave bands (Hz)								Lw dB(A)
	63	125	250	500	1000	2000	4000	8000	
	Sound pressure level (dB)								
040	49,9	45,9	41,3	37,1	34,7	49,9	32,4	21,4	72,0
060	46,9	42,9	38,3	34,1	31,7	46,9	29,4	18,4	69,0
070	47,9	43,9	39,3	35,1	32,7	47,9	30,4	19,4	70,0
080	48,8	44,8	40,2	36,0	33,6	48,8	31,3	20,3	71,0
100	49,3	45,3	40,7	36,5	34,1	49,3	31,8	20,8	71,5
110	55,8	51,8	47,2	43,0	40,6	55,8	38,3	27,3	78,0

SOUND POWER LEVEL FULL LOAD

Operating conditions:

Evaporation temperature 5°C - outdoor temp. 35°C.

Testing point:

Average sound pressure levels calculated according to ISO 3744 at 10 mt distance from unit.

Measurement conditions:

Free field on reflecting surface (Q factor Q=2).

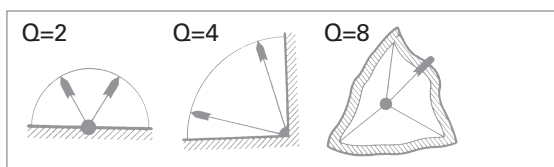

- For units installed in the presence of 2 reflecting surfaces (Q factor Q=4) 3 dB have to be added at values above mentioned.
- For units installed in the presence of 3 reflecting surfaces (Q factor Q=8) 6 dB have to be added at values above mentioned.
- For units installed at a certain height from the ground, the sound energy coming out from the bottom of the unit leads an increase of the noise pressure level of around 3 dB.

Sound emission values in octave bands are shown just as an indication and they are not to be considered as a commitment.

Sound pressure values, according to ISO 3744 standards and in observance of EUROVENT certification program, are the only ones to be used for every calculation to make a prevision of the sound pressure level at the operating conditions.

The sound pressure level data are not binding. For a more precise value please refer to the sound power level.

Installation and sizing of refrigerant piping

REFRIGERANT PIPES SIZING

The pipe sizing shall be made with the aim to ensure a proper refrigerant speed and therefore a correct oil return.

The suction line usually is sized so as to maintain a speed higher than 4 m/s to the minimum load (minimum capacity step) and lower than 20 m/s at full load.

PIPE LINES DIAMETER

Unit size		040	060	070	080	100	110
① Suction line		18	22	22	28	28	28
② Liquid line	mm	12	12	12	16	16	16

These diameters shall be considered approximate and must be verified for each installation.

MAXIMUM ALLOWED DISTANCE BETWEEN INDOOR AND OUTDOOR UNITS

Oil traps shall be installed at the base of each vertical section with upward flow direction; a very long vertical pipe shall be equipped with an oil trap every 3-4 m distance.

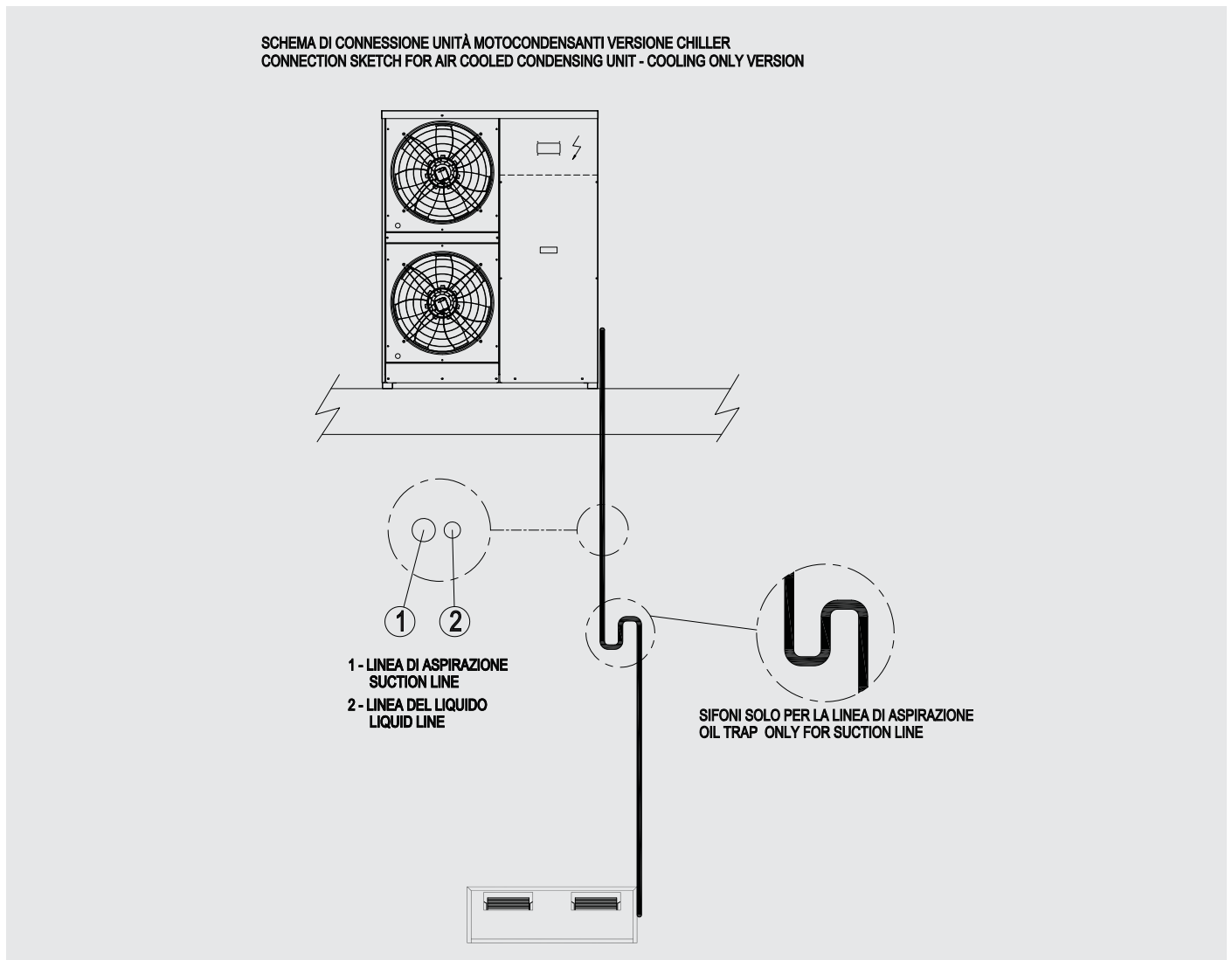

Installation and sizing of refrigerant piping

LIQUID RECEIVER SIZING AND INSTALLATION

The installation of the liquid receiver is a designer's responsibility.

In case of maintenance the liquid receiver may be used to stock the entire refrigerant volume of the plant.

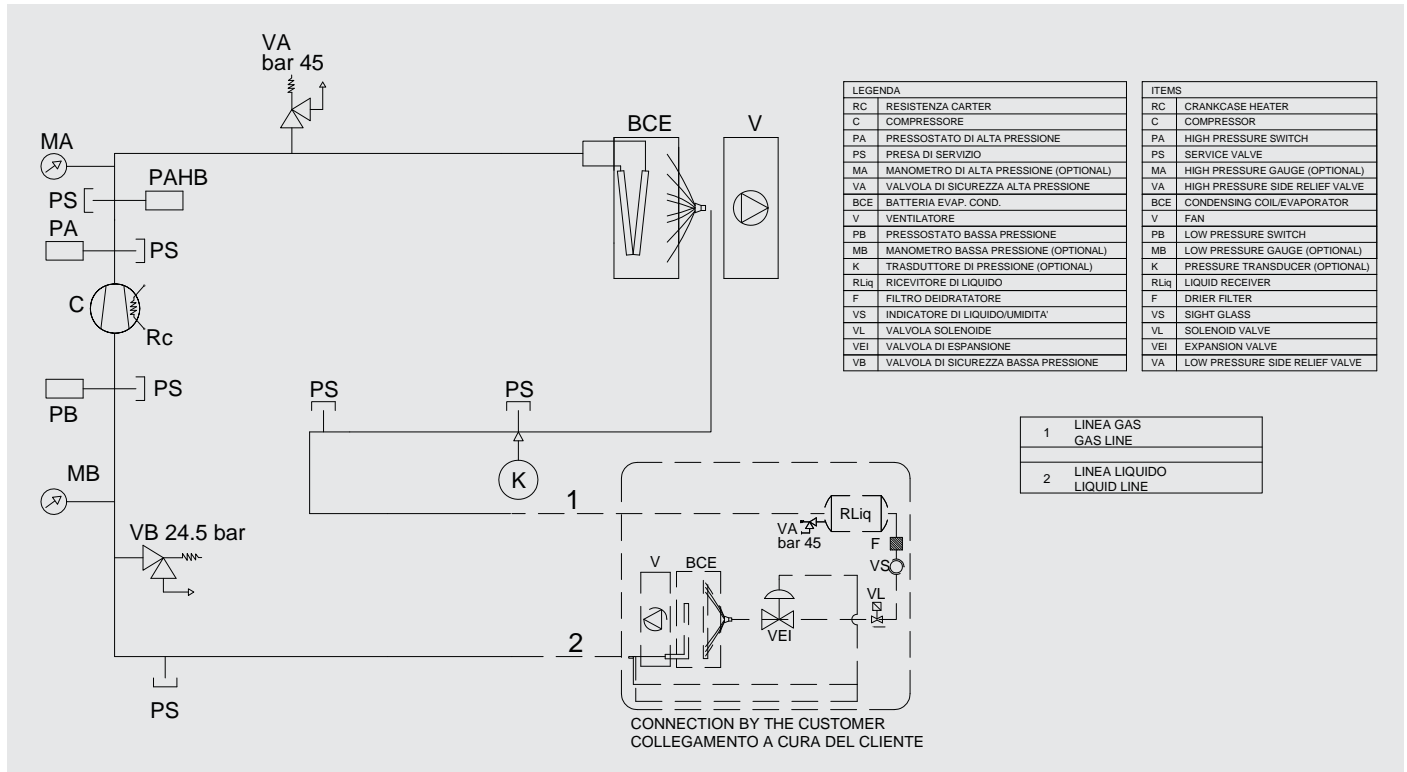

ADDITIONAL R410A REFRIGERANT CHARGE FOR A LINEAR METER OF PIPE

Diameter (mm)	Gas (Kg/m)	Liquid (Kg/m)
6	0.0014	0.0133
10	0.005	0.051
12	0.008	0.079
16	0.014	0.139
18	0.019	0.182
22	0.029	0.285
28	0.045	0.445
35	0.074	0.729
42	0.111	1.082
54	0.182	1.779
64	0.281	2.721
67	0.289	2.825
76	0.377	3.689

Dimensions and weights

040

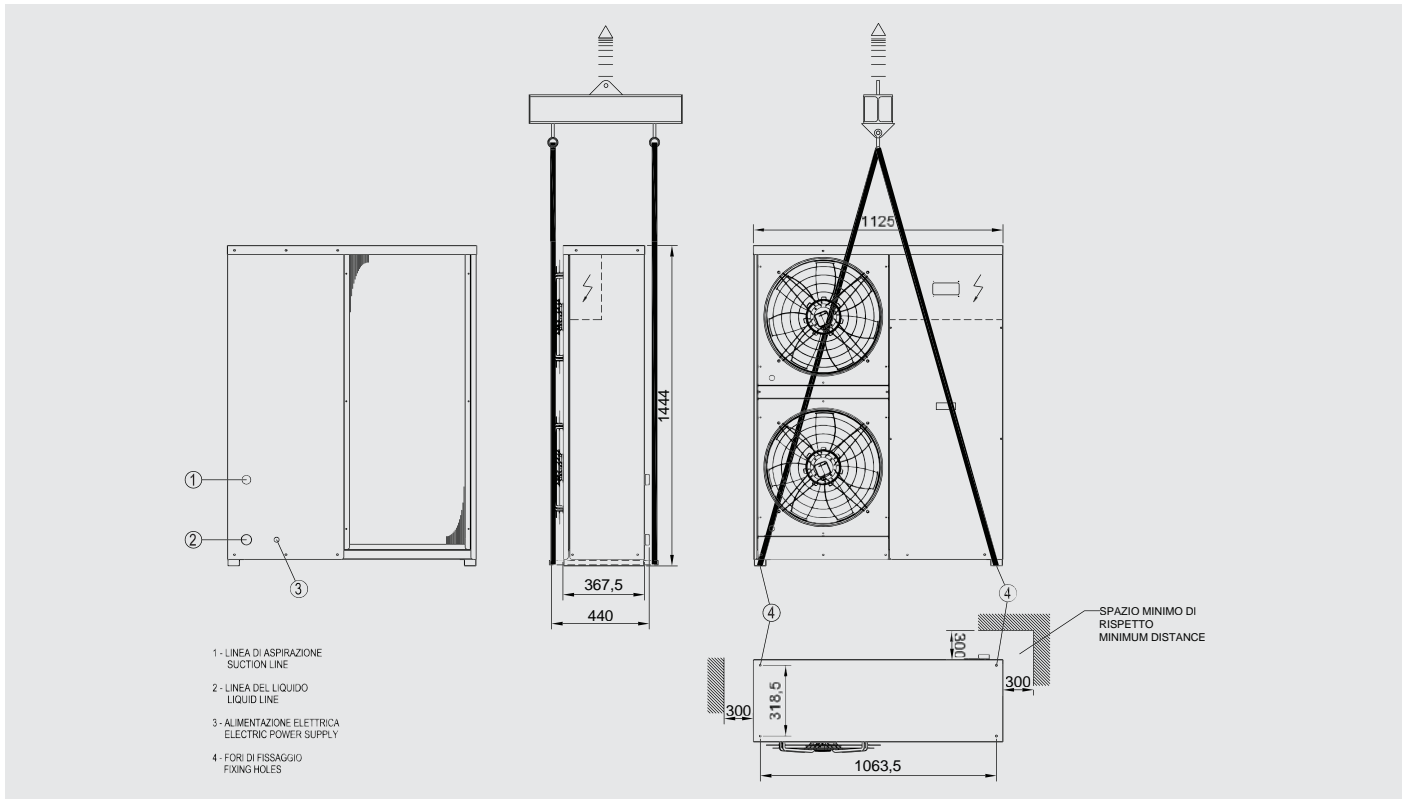

060 - 070

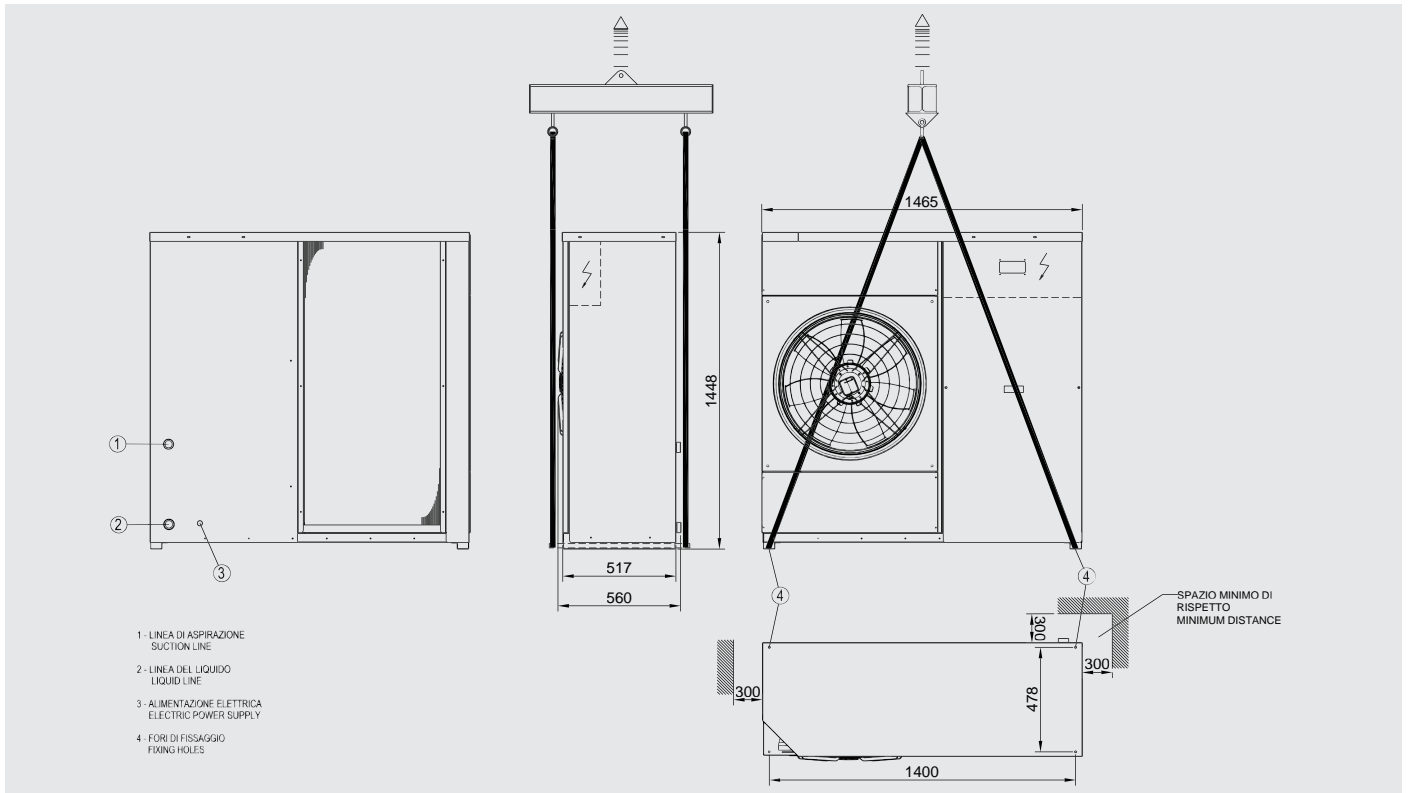

Dimensions and weights

080 - 110

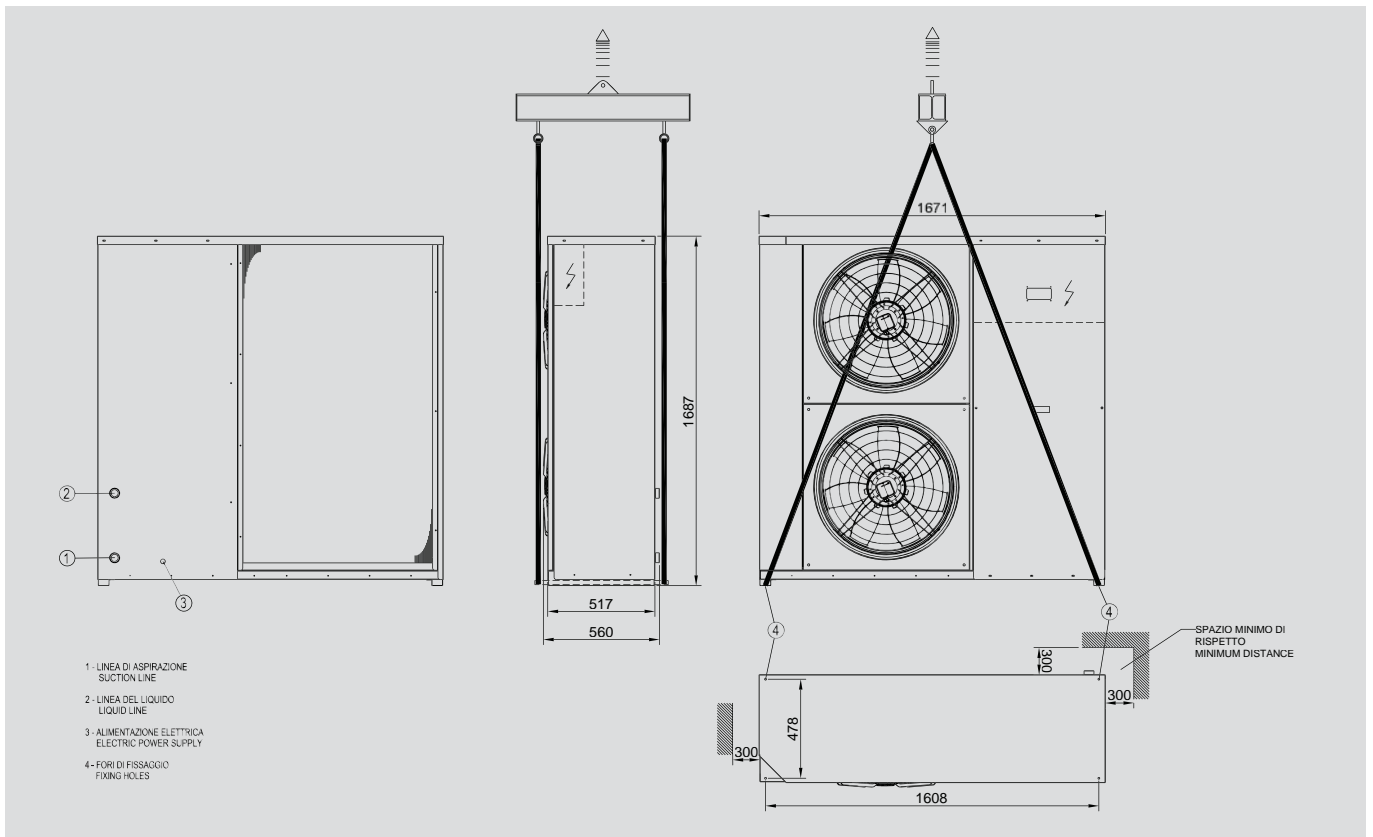

WEIGHTS

OPERATING WEIGHTS

Unit size		040	060	070	080	100	110
Standard unit	kg	168	246	255	288	291	301

SHIPPING WEIGHTS

Unit size		040	060	070	080	100	110
Standard unit	kg	163	241	249	282	285	293

Dimensions and weights

REFRIGERANT CONNECTION

The liquid and suction lines present rotalock connection.
Rotalock / welded connection are included as standard equipments but supplied separately.

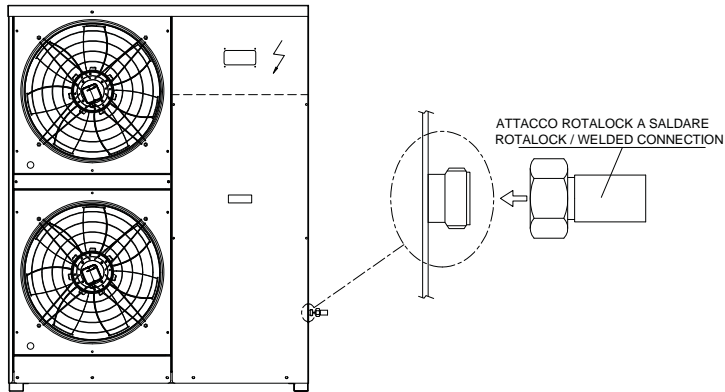

Service valves are available as options, supplied separately.

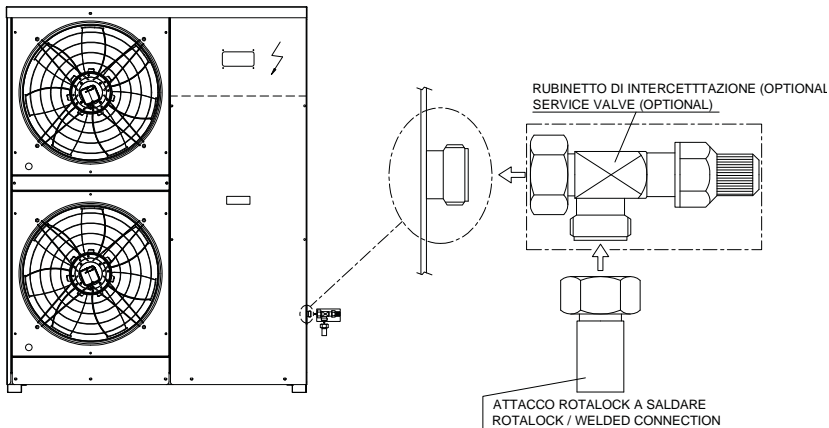

CONNECTION DIAMETERS

PIPE LINES

Unit size		040	060	070	080	100	110
①	mm	18	22	22	28	28	28
②		12	12	12	16	16	16

CONNECTIONS

Unit size		040	060	070	080	100	110
①	Rotalock	1"¼	1"¼	1"¼	1"¼	1"¼	1"¼
②		1"	1"	1"	1"¼	1"¼	1"¼

- ① Suction line
- ② Liquid line



Notes



Notes



Notes



Trane optimizes the performance of homes and buildings around the world. A business of Ingersoll Rand, the leader in creating and sustaining safe, comfortable and energy efficient environments, Trane offers a broad portfolio of advanced controls and HVAC systems, comprehensive building services and parts. For more information visit www.Trane.com

Trane has a policy of continuous product and product data improvement and reserves the right to change design and specifications without notice.

© 2015 Trane All rights reserved
RAUS-PRC001A-GB May 2015

We are committed to using environmentally
conscious print practices that reduce waste.

