



Water-cooled chillers with High Speed Centrifugal Compressors

Refrigerant R134a

GVWF 190 - 760 (395 to 2660 kW)

Refrigerant R1234ze

GVWF 135 G - 505 G (310 to 1820 kW)



XSTREAM
EXCELLENT

CTV-PRC019C-GB



Table of Contents

Introduction	3
Features and benefits.....	4
Base unit description	7
Options description.....	8
General Data	10
Operating Map.....	12
Pressure drop	13
Electrical Data	17
Acoustic Data.....	18

Introduction

The new **Trane XStream™ Excellent** series is the result of a search for higher reliability and higher energy efficiency, for today's environment.

XStream Excellent come in two versions to allow customers to make the best choice according to his main criteria, whether they are economical or environmental:

XStream Excellent GVWF with R134a refrigerant

XStream Excellent GVWF G with R1234ze refrigerant

EcoWise[™]

XStream™ Excellent GVWF G chillers with **R1234ze** low GWP refrigerants are part of the Ingersoll Rand **EcoWise™** portfolio of products that are designed to lower their environmental impact with next-generation, low global warming potential (GWP) refrigerants and high-efficiency operation.

In an effort to reduce energy consumed by cooling and to continually operate, Trane has developed the **XStream Excellent** chillers with higher efficiencies and a more reliable design than any other water-to-water equipment available on the market today.

The **XStream Excellent** uses the High Speed Centrifugal compressors.

The industrial-grade design of this chillers is ideal for both industrial and commercial markets, in applications such as office buildings, hospitals, schools, retail buildings, and industrial facilities.

The major advantages of the **XStream Excellent** are:

- Very low environmental impact thanks to near zero GWP (<1) R1234ze refrigerant.
- High efficiencies specially at part load
- Great versatility to adapt to varying applications requirements

Features and benefits

High Speed Centrifugal Compressors

- **Two stages, high speed centrifugal compressors with higher aerodynamic efficiency**
- **Magnetic bearings provide quiet, reliable and 100% oil free operation**
- **Soft start module significantly reduces high in-rush current at startup**
- **Integrated variable frequency drive**
- **Variable speed adjusts to changes in load and/or condensing temperature**
- **One main moving part. The two impellers are keyed directly to the motor rotor.**

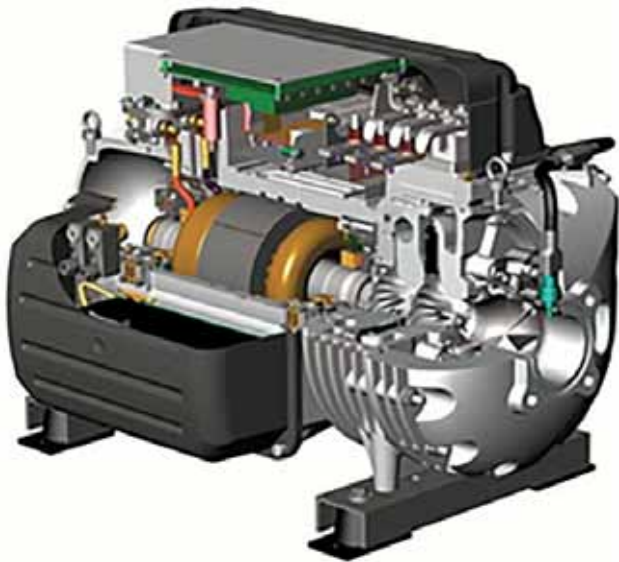

CHIL evaporator

Trane developed an evaporator specially designed for **XStream Excellent** chillers. Compact - High performance - Integrated design - Low charge (CHIL) evaporator optimizes the flow of the refrigerant to get an excellent heat exchange with water in every operating condition and minimize the quantity of refrigerant used;

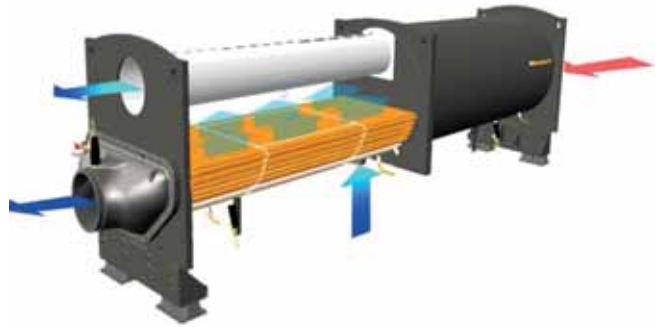

Features and benefits

Variable Primary Flow

An attractive chilled-water system option may be a variable primary flow (VPF) system. VPF systems present building owners with several cost-saving benefits that are directly related to the pumps. The most obvious cost savings result from eliminating the secondary distribution pump, which in turn avoids the expense incurred with the associated piping connections (material, labor), electrical service, and variable-frequency drive.

Building owners often cite pump related energy savings as the reason that prompted them to install a VPF system. With the help of a TRANE software analysis tool, you can determine whether the anticipated energy savings justify the use of variable primary flow in a particular application. It may also be easier to apply variable primary flow in an existing chilled-water plant.

Unlike the “decoupled” design, the bypass can be positioned at various points in the chilled-water loop and an additional pump is unnecessary. The evaporator in the **XStream Excellent** series can withstand up to 50% percent water flow reduction as long as this flow is equal to or above the minimum flow-rate requirements. The microprocessor and capacity control algorithms are designed to handle a maximum of 10% change in water flow rate per minute in order to maintain $\pm 0.3^{\circ}\text{C}$ leaving evaporator temperature control. For applications in which system energy savings is most important and tight temperature control is classified as $\pm 1.1^{\circ}\text{C}$, up to 30% changes in flow per minute are possible.

Factory Testing Means Trouble-Free Start-up

All **XStream Excellent** chillers are given a complete functional test at the factory. This computer-based test program completely checks the sensors, wiring, electrical components, microprocessor function, communication capability, expansion valve performance, and fans. In addition, each compressor is run-tested to verify capacity and efficiency. Where applicable, each unit is factory preset to the customer’s design conditions. An example would be the leaving-liquid temperature set point. The result of this test program is that the chiller arrives at the job site fully tested and ready for operation.

Factory-Installed and Tested Controls and Options Speed Installation

All **XStream Excellent** chiller options are factory installed and tested. Some manufacturers send accessories in pieces to be field installed. With Trane, the customer saves on installation expense and has assurance that ALL chiller controls and options have been tested and will function as expected.

Superior Control with UC 800™ Chiller controls

The Adaptive Control™ microprocessor system enhances the **XStream Excellent** chiller by providing the very latest chiller control technology. With the Adaptive Control microprocessor, unnecessary service calls and unhappy tenants are avoided. The unit does not nuisance-trip or unnecessarily shut down. Only when the chiller controls have exhausted all possible corrective actions and the unit is still violating an operating limit, will the chiller shut down. Controls on other equipment typically shut down the chiller, usually just when it is needed the most.



Features and benefits

SmartFlow control

XStream Excellent series units are fully compatible with variable flow operation both on evaporator and condenser sides. The modulation of the pump speed is managed to ensure that chiller ΔT stays constant. Entering and leaving temperatures at the evaporator will be measured directly by the chiller controller, through the factory-supplied sensor. A ΔT setpoint will be present on the unit controller. The option for constant ΔT is intended to be used with 3-way valves on water systems, or 2-way valves on water system but constant flow at the by-pass.

Series counterflow chiller configuration

When considering multiple chillers plant, designers conventionally go for parallel-piped chillers configuration. Nevertheless, there are ways to bring more efficiency by using a different chiller lay-out. An effective alternative to consider is to pipe the chillers in series. Larger ΔT and low flow design save energy on the pumping. Series chiller configuration allows as well, to get a better efficiency from the upstream chiller, more lightly loaded. Combining this configuration with Variable Primary Flow (VPF) will further increase system efficiency.

Series piping principle can also be applied to condenser side. This is called Series-Series counterflow configuration. This will result in similar advantages on the condenser side, enlarging the opportunity for savings on the overall system.

For more information on Series chillers arrangements, refer to Trane Application Engineering Manual about Multiple-Chiller system design and control (SYS-AP M001).

Product certification

Trane as a Global leader in the HVAC industry participates to both Eurovent and AHRI chillers certification programs. Through this third party certifications, Trane commits to deliver units that comply with the declared performance.



Base unit description

	GVWF	GVWF G
Power supply	400 V - 3 Ph - 50 Hz - Single point	
Compressor type	High Speed Centrifugal	
Compressor technology	Magnetic bearings – Oil free	
Number of circuits	2	
Compliance	CE - PED	
Refrigerant	R134a	R1234ze
Relief valve	Single relief valve on condenser	
Evaporator water connections	Direct Connection - Grooved pipes	
Evaporator water side pressure	10 bars	
Condenser water connections	Direct Connection - Grooved pipes	
Condenser water side pressure	10 bars	
Flow Control	Constant Flow - Pump signal On/Off (Condenser + Evaporator)	
Power protection	Fused	
Electrical IP protection	Enclosure with Dead Front protection	
Installation accessories	Optional	

Options description

Option Description		Application	
Power			
400 V - 3 Ph - 50 Hz - Dual point	2 distinct power supplies, one per circuit - available for units of group 2, see below	Renovation. Replacement of two smaller units by one only.	●
Disconnect switch with Fuses		Power protection	●
Disconnect Switch with Circuit Breakers		Power protection	●
Condenser Application			
Hot Water Leaving temperature control		Water to Water Heat Pump	●
Acoustics			
Sound attenuation package	Additional refrigerant lines insulation	Overall reduction of Sound Power level by -3dB(A)	●
Relief Valve			
Single relief Valve on both condenser and evaporator	Additional relief valve on Low pressure side	Additional pressure safety device	●
Dual Relief valve on condenser only	2 relief valve with bypass 3 way valve on high pressure side	Maintenance	●
Dual relief Valve on both evaporator and condenser	2 relief valve with bypass 3 way valve on both high and low side	Maintenance	●
Evaporator water connection			
Left hand Connection	Position of water box on the right side of the unit (facing control panel) - available for units of group 1, see below Additional pipe allowing Evaporator connections on the right side of the unit (facing control panel) - available for units of group 2, see below)	Supply and return water on the same side of the unit	●
Right hand connection	Position of water box on the left side of the unit (facing control panel) - available for units of group 1, see below Additional pipe allowing Evaporator connections on the left side of the unit (facing control panel) - available for units of group 2, see below)	Supply and return water on the same side of the unit	●
No insulation on cold parts	Unit delivered without insulation on Evaporator and cold parts	For field supplied insulation by customer	●
Condenser water connection			
Left hand Connection	Position of water box on the right side of the unit (facing control panel) for GVWF 190-215-260-300-135G-160G-185G-210G-250G only Additional pipe allowing Evaporator connections on the right side of the unit (facing control panel)	Supply and return water on the same side of the unit	●
Right hand connection	Position of water box on the left side of the unit (facing control panel) for GVWF 190-215-260-300-135G-160G-185G-210G-250G only Additional pipe allowing Evaporator connections on the left side of the unit (facing control panel)	Supply and return water on the same side of the unit	●
Condenser thermal insulation	Thermal insulation of condenser	Heat Pump application to avoid wasted heat	

Options description

SmartFlow Control			
VPF Constant DeltaT Evaporator	Optional PC board delivering a 2-10 V modulating signal output to control a pump motor speed inverter	Evaporator variable speed pump control based on a constant Delta T	●
VPF Constant DeltaT Condenser	Optional PC board delivering a 2-10 V modulating signal output to control a pump motor speed inverter	Condenser variable speed pump control based on a constant Delta T	●
VPF Constant DeltaT Evaporator and Condenser	Optional PC board delivering a 2-10 V modulating signal output to control a pump motor speed inverter	Evaporator and Condenser variable speed pump control based on constant Delta T's	●
Smart Com protocole			
BACNet MSTP interface	Communication card	Communication with BMS through BACNet MSTP Protocol	●
BACNet IP interface	Communication card	Communication with BMS through BACNet IP Protocol	●
ModBus RTU interface	Communication card	Communication with BMS through Modbus Protocol	●
LonTalk Interface	Communication card	Communication with BMS through LonTalk Protocol	●
External setpoints & capacity outputs	Programmable Input/Output card and sensors	Remote Control or remote monitoring	●
Outdoor Air Temp Sensor	With Outdoor Air Temp Sensor	Measurement of Outdoor ambient air temp to perform water set point offset	●
Electrical IP Protection	IP 20 protection	Electrical safety	
Master slave operation	Communication card	Operation of two chillers on a same water loop	●
Energy metering	Additional energy meter	Monitors electricity consumption (kWh) of the full unit	●
Condenser Refrigerant Pressure Output			
Condenser Water Control Output	Communication card - 0-10 V Analog output	Allows to control a valve on condenser loop to perform proper unit start when condenser water loop is cold	●
Condenser Pressure (%HPC) Output	Communication card - 0-10 V Analog output	Allows control of cooling device based on condenser pressure (I.e. Cooling tower fan, 3-Way valve....)	●
Differential Pressure Output	Communication card - 0-10 V Analog output	Allows control of a 3-way valve on condenser water loop	●
Power socket	230 V Power socket	Local Power source to connect an electrical device such as a Laptop	●
Flow Switch			
Evaporator or Condenser Flow switch	One Flow Switch delivered to be installed either on Evaporator or Condenser side	Allows to check flow detection	▲
Evaporator and Condenser Flow switch	Two Flow Switches delivered to be installed respectively on Evaporator and Condenser side	Allows to check flow detection	▲
Accessories			
Neoprene isolators			▲
Neoprene pads			▲
Grooved pipe with coupling & pipe stub	4 Grooved pipe adapters	Allows welded connection to unit	▲

● Factory mounted ▲ Accessory (not fitted)

Product groups

GVWF	190	215	260	300	275	320	325	390	370	380	410	420	480	590	515	570	695	760	135 G	160 G	185 G	210 G	220 G	250 G	270 G	290 G	350 G	375 G	405 G	465 G	505 G	
Group 1	●	●	●	●																●	●	●	●	●								
Group 2					●	●	●	●	●	●	●	●	●	●	●	●	●	●							●	●	●	●	●	●	●	●

General Data

GVWF (R134a)

		GVWF 190	GVWF 215	GVWF 260	GVWF 300	GVWF 325	GVWF 390	GVWF 275	GVWF 320	GVWF 370	GVWF 380	GVWF 410	GVWF 420	GVWF 480	GVWF 590	GVWF 515	GVWF 570	GVWF 695	GVWF 760
Compressor Lift		High	High	High	Low	Low	Low	High	High	Low	High	Low	Low	Low	Low	High	Low	Low	Low
Mac. Cooling Cap	kW	684	828	972	1056	1230	1425	1031	1167	1424	1439	1697	1582	1776	2069	1924	2123	2430	2662
Gross Performances (1)																			
Cooling Cap at Optimum SEER	kW	546.0	661.0	776.0	859.0	1089.0	1425.0	721.0	871.0	1280.0	1115.0	1271.0	1106.0	1347.0	1861.0	1538.0	1909.0	1943.0	1863.0
Power Input	kW	99.5	120.8	138.8	150.5	187.8	244.0	122.4	152.1	222.3	192.1	210.9	190.2	233.8	312.9	265.5	341.6	326.1	326.0
EER		5.49	5.47	5.59	5.71	5.80	5.84	5.89	5.73	5.76	5.81	6.03	5.82	5.76	5.95	5.79	5.59	5.96	5.71
ESEER (Not certified)		8.60	8.48	8.49	8.70	9.11	9.16	9.24	9.10	9.27	9.08	9.20	9.14	9.20	9.46	9.26	9.17	9.35	9.45
Net Performances (1) (2)																			
Cooling Cap at Optimum SEER	kW	545.5	660.5	775.4	858.4	1088.3	1424.3	720.6	870.4	1279.4	1114.3	1270.4	1105.3	1346.3	1860.4	1537.2	1908.1	1942.4	1862.4
Power Input	kW	103.9	125.3	144.2	1574	193.0	249.9	124.9	156.0	226.9	197.7	215.4	195.7	239.0	317.8	272.8	352.4	331.6	331.0
EER		5.25	5.27	5.38	5.45	5.64	5.70	5.77	5.58	5.64	5.64	5.90	5.65	5.63	5.85	5.64	5.42	5.86	5.63
Eurovent Energy class - Cooling		A	A	A	A	A	A	A	A	A	A	A	A	A	A	A	A	A	A
ESEER (Not certified)		7.21	7.31	7.29	7.29	8.10	8.26	8.46	8.17	8.48	8.06	8.44	8.11	8.36	8.83	8.23	7.99	8.70	8.81
SEER (3)		8.20	8.03	7.93	8.25	8.58	8.83	8.78	8.70	8.78	8.78	8.88	8.68	8.83	9.08	8.93	8.98	9.00	9.00
Space Cooling Efficiency $\eta_{s,c}$ (3)	(%)	320	313	309	322	335	345	343	340	343	343	347	339	345	355	349	351	352	352
Compressor																			
Circuit 1		1	1	1	1	1	1	2	2	2	2	2	2	2	2	2	2	2	2
Circuit 2		1	1	1	1	1	1	1	1	1	1	1	1	1	1	2	2	2	2
Evaporator																			
Pass		2	2	2	2	1	1	1	1	1	1	1	1	1	1	1	1	1	1
Nominal Flow (1)	l/s	18.8	22.8	26.9	29.6	42.1	61.1	26.4	32.2	46.5	43.1	56.5	39.8	50.7	81.7	52.1	69.7	86.6	99.6
Pressure Drop (1)	kPa	28	23	24	24	30	30	15	23	17	32	25	27	20	15	22	29	17	23
Minimum Flow	l/s	11.8	15.5	18.2	20.0	23.2	34.0	20.4	20.4	34.0	23.2	34.0	23.2	34.0	64.0	34.0	39.4	64.0	64.0
Maximum Flow	l/s	43.2	56.8	66.7	73.3	85.1	124.7	74.8	74.8	124.7	85.1	124.7	85.1	124.7	234.0	124.7	144.5	234.0	234.0
Water Connection Type		Grooved end																	
Water Connection Size	in	5	6	6	6	6	8	6	6	8	6	8	6	8	10	8	8	10	10
Condenser																			
Pass		2	2	2	2	1	1	1	1	1	1	1	1	1	1	1	1	1	1
Nominal Flow (1)	l/s	22.3	27.0	31.9	35.2	49.9	72.0	31.1	38.0	54.9	50.8	66.6	47.1	60.2	96.7	61.4	82.3	102.2	118.0
Pressure Drop (1)	kPa	25.8	21.5	23.5	32.2	11.4	14.8	8.5	10.2	8.5	11.8	12.7	10.1	10.3	12.3	10.7	17.5	13.8	18.4
Minimum Flow	l/s	13.0	18.0	20.5	20.5	45.8	53	29.9	34.3	53	45.8	53	45.8	53	91	53	56.4	91	91
Maximum Flow	l/s	47.6	66.0	75.2	75.2	167.9	194.5	109.5	125.7	194.5	167.9	194.5	167.9	194.5	333.0	194.5	206.8	333.0	333.0
Water Connection Type		Grooved end																	
Water Connection Size	in	6	6	6	6	6	8	6	6	8	6	8	6	8	10	8	8	10	10
Refrigerant																			
Type		R134a																	
Charge Circuit 1	kg	71	83	85	91	213	205	219	216	205	213	205	213	205	315	205	230	315	315
Charge Circuit 2	kg	71	83	85	91	93	205	104	99	205	93	205	93	205	310	205	230	315	315
Dimensions & weight																			
Length	mm	2976	2976	2976	3476	4730	4804	4730	4730	4804	4730	4804	4730	4804	5245	4804	4804	5444	5444
Width	mm	1125	1125	1125	1125	1700	1800	1700	1700	1800	1700	1800	1700	1800	2141	1800	1800	2141	2141
Height	mm	1920	1920	1920	1920	2032	2135	2032	2032	2135	2032	2135	2032	2135	2315	2135	2135	2315	2315
Operating weight	kg	2310	2810	3020	3370	4094	4954	4110	4102	5177	4317	5177	4317	5177	8076	5401	5574	8263	8323

(1) Evaporator 12/7°C and 0.0 m²K/kW, and condenser at 30/35°C and 0.0 m²K/kW.

(2) Net performances calculated as per EN 14511-2013.

(3) $\eta_{s,c}$ / SEER as defined in Directive 2009/125/EC of the European Parliament and of the Council with regard to Ecodesign requirements for Comfort Chillers with 2000 kW maximum capacity - COMMISSION REGULATION (EU) N° 2016/2281 of 20 December 2016.

GVWF G (R1234ze)

	GVWF 135 G	GVWF 160 G	GVWF 185 G	GVWF 210 G	GVWF 220 G	GVWF 250 G	GVWF 270 G	GVWF 290 G	GVWF 350 G	GVWF 375 G	GVWF 405 G	GVWF 465 G	GVWF 505 G	
Compressor Lift	High	High	High	Low	Low	Low	High	Low	Low	High	Low	Low	Low	
Mac Cooling Cap	kW	422	530	613	659	787	850	764	942	1120	1018	1356	1352	1672
Gross Performances (1)														
Cooling Cap at Optimum SEER	kW	422.0	530.0	613.0	659.0	787	850.0	764.0	942.0	1120.0	1018.0	1356.0	1352.0	1672.0
Power Input	kW	77	100	113	121	5.32	155	128	164	204	166	240	245	280
EER		5.45	5.28	5.44	5.44	8.46	5.50	5.99	5.73	5.48	6.12	5.65	5.53	5.98
ESEER (Not certified)		8.39	8.35	8.39	8.17	7.10	8.19	9.24	8.92	8.95	9.48	9.17	9.23	9.16
Net Performances (1) (2)														
Cooling Cap at Optimum SEER	kW	421.6	529.5	612.4	658.5	786.0	849.4	763.5	941.4	1119.3	1017.5	1355.3	1351.4	1669.0
Power Input	kW	80	105	118	126	154	161	131	168	210	170	247	249	283
EER		5.25	5.05	5.17	5.22	5.09	5.27	5.85	5.59	5.33	5.99	5.50	5.43	5.90
Eurovent Energy class - Cooling		A	A	A	A	A	A	A	A	A	A	A	A	A
ESEER (Not certified)		7.24	7.00	6.93	6.97	6.25	6.94	8.39	8.03	7.90	8.68	8.14	8.49	8.65
SEER (3)		7.88	7.88	7.90	7.73	7.63	7.53	8.78	8.58	8.50	9.00	8.85	8.75	8.83
Space Cooling Efficiency $\eta_{s,c}$ (3)	(%)	307	307	308	301	297	293	343	335	332	352	346	342	345
Compressor														
Circuit 1		1	1	1	1	1	1	2	2	2	2	2	2	2
Circuit 2		1	1	1	1	1	1	1	1	1	2	2	2	2
Evaporator														
Pass		2	2	2	2	2	2	1	1	1	1	1	1	1
Nominal Flow (1)	l/s	14.9	17.1	20.7	23.7	30.7	38.0	28.3	33.2	46.5	37.7	56.3	69.7	79.64
Pressure Drop (1)	kPa	20.2	22.6	29.5	25.0	30.9	40.0	17.4	18.9	36.9	16.1	30.1	29.2	14.68
Minimum Flow	l/s	10.8	11.8	12.6	15.5	18.2	20.0	20.4	23.2	23.2	28.2	30.8	39.4	64
Maximum Flow	l/s	39.6	43.2	46.2	56.8	66.7	73.3	74.8	85.1	85.1	103.4	113.0	144.5	234
Water Connection Type		Grooved end												
Water Connection Size	in	5	5	5	6	6	6	6	6	6	8	8	8	10
Condenser														
Pass		2	2	2	2	2	2	1	1	1	1	1	1	1
Nominal Flow (1)	l/s	17.6	20.2	24.5	28.2	36.6	45.4	33.3	39.2	55.7	44.2	66.5	83.1	93.94
Pressure Drop (1)	kPa	22.8	25.0	30.6	29.6	30.0	50.5	9.8	10.9	14.3	8.5	17.2	17.8	11.59
Minimum Flow	l/s	10.9	11.9	13.0	15.4	20.5	20.5	29.9	34.3	45.8	41.4	44.2	56.4	91.0
Maximum Flow	l/s	40.0	43.8	47.6	56.5	75.2	75.2	109.5	125.7	167.9	151.6	162.0	206.8	333.0
Water Connection Type		Grooved end												
Water Connection Size	in	6	6	6	6	6	6	6	6	6	8	8	8	10
Refrigerant														
Type		R1234ze												
Charge Circuit 1	kg	67	65	65	77	80	89	210	206	204	169	176	221	303
Charge Circuit 2	kg	67	65	65	77	80	89	100	92	89	169	176	221	303
Dimensions & weight														
Length	mm	2976	2976	2976	2976	2976	3476	4730	4730	4730	4804	4804	4804	5444
Width	mm	1125	1125	1125	1125	1125	1125	1700	1700	1700	1800	1800	1800	2141
Height	mm	1920	1920	1920	1920	1920	1920	2032	2032	2032	2135	2135	2135	2315
Operating weight	kg	2130	2280	2420	2740	3000	3380	4025	4085	4304	5002	5128	5556	8239

(1) Evaporator 12/7°C and 0.0 m²K/kW, and condenser at 30/35°C and 0.0 m²K/kW.

(2) Net performances calculated as per EN 14511-2013.

(3) $\eta_{s,c}$ / SEER as defined in Directive 2009/125/EC of the European Parliament and of the Council with regard to Ecodesign requirements for Comfort Chillers with 2000 kW maximum capacity - COMMISSION REGULATION (EU) N° 2016/2281 of 20 December 2016.

Operating Map

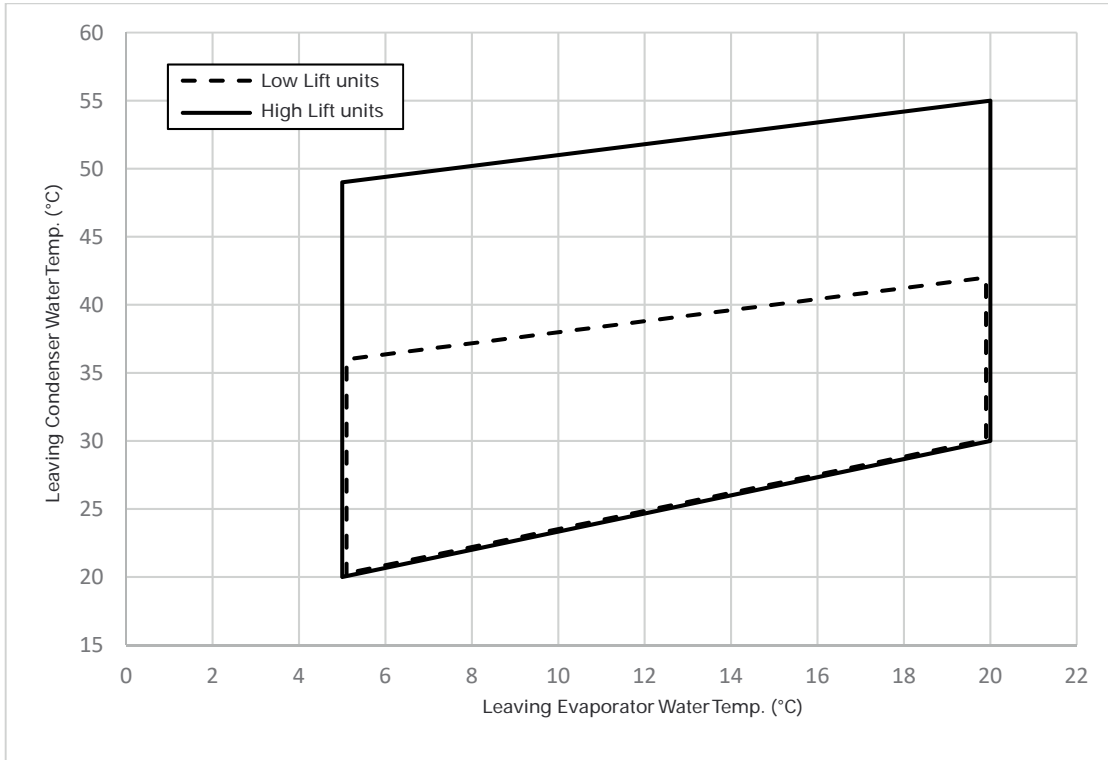

Pressure drop

Evaporator pressure drop

GVWF - Evaporator pressure drop

GVWF - Evaporator pressure drop

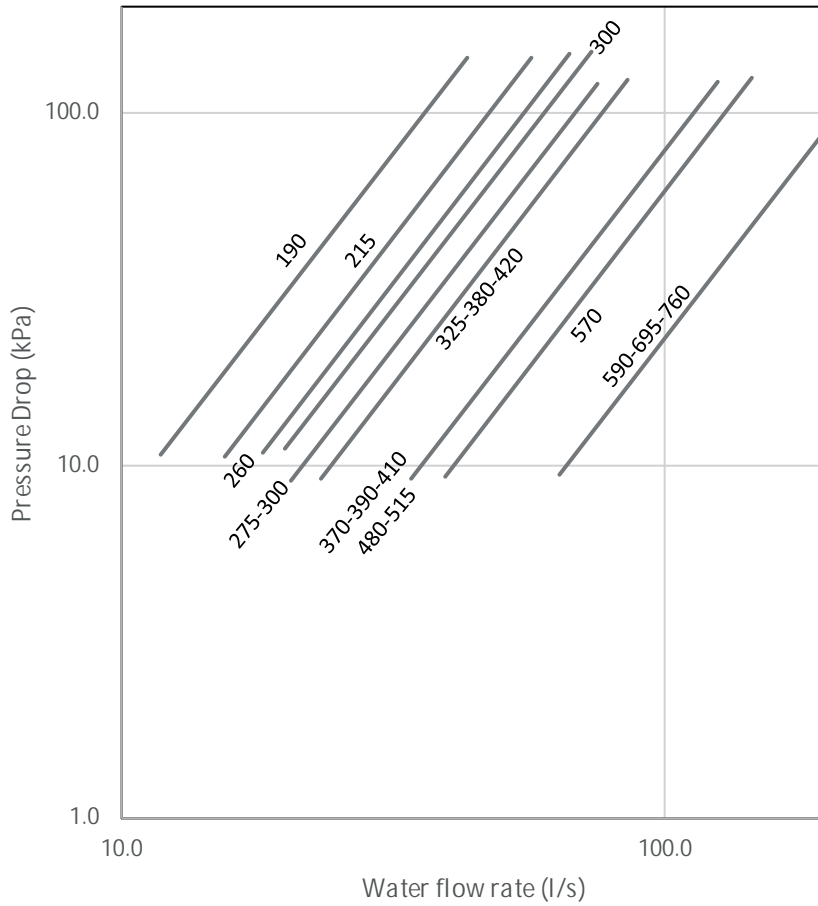

Pressure drop

GVWF G - Evaporator pressure drop

GVWF G - Evaporator pressure drop

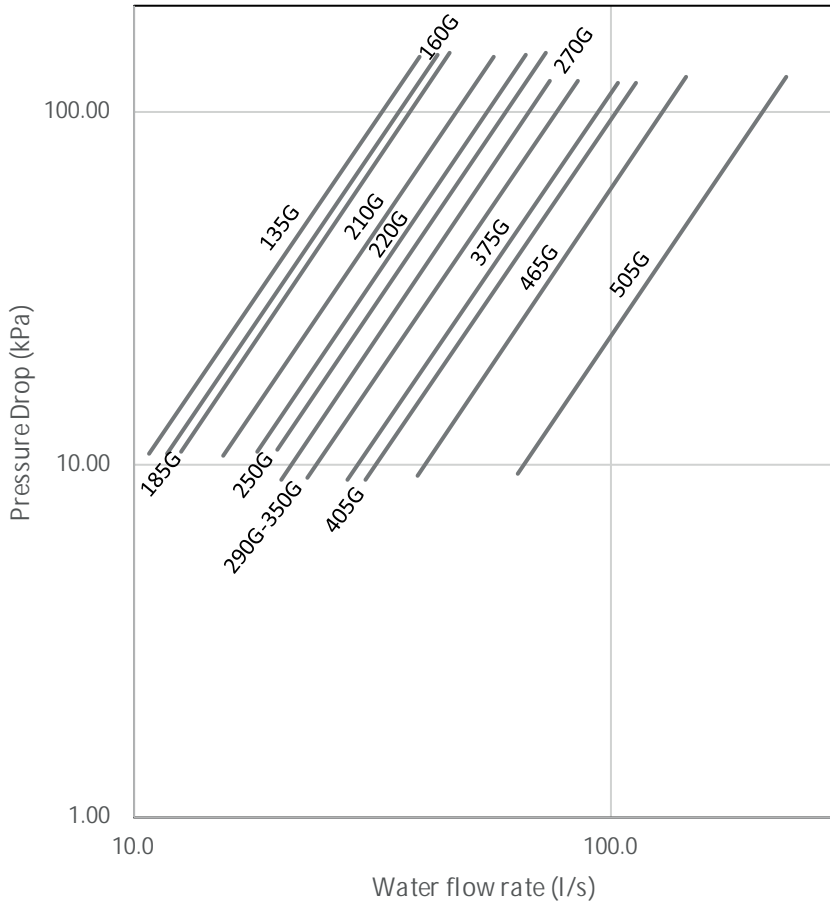

Pressure drop

Condenser pressure drop

GVWF - Condenser pressure drop

GVWF - Condenser pressure drop

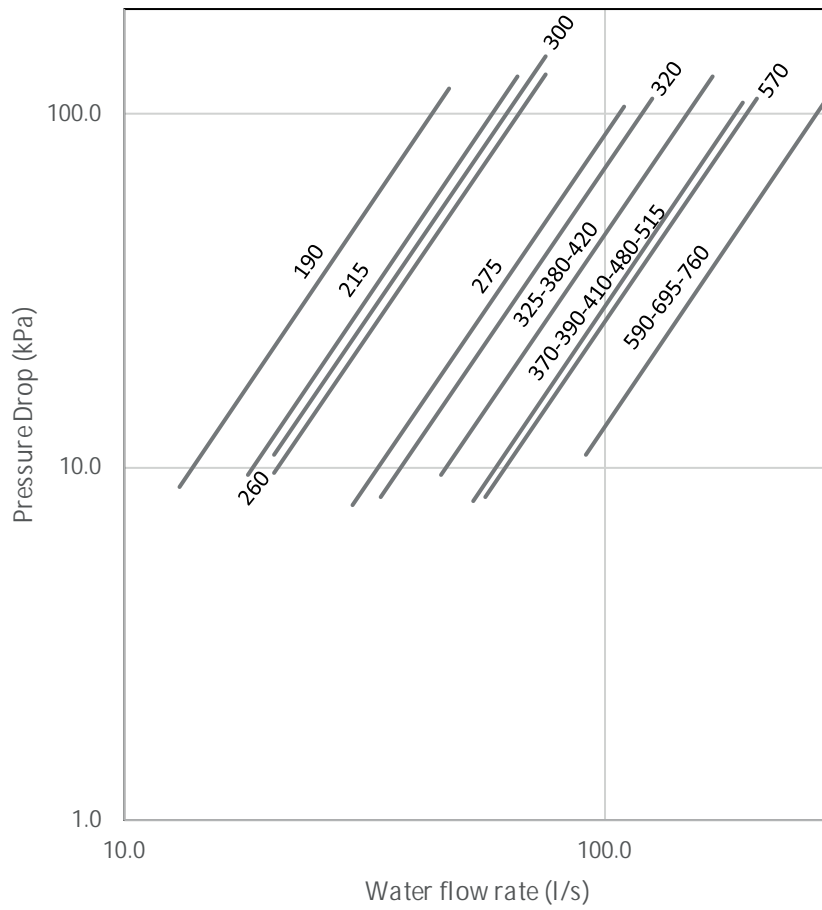

Pressure drop

GVWF G - Condenser pressure drop

GVWF G - Condenser pressure drop

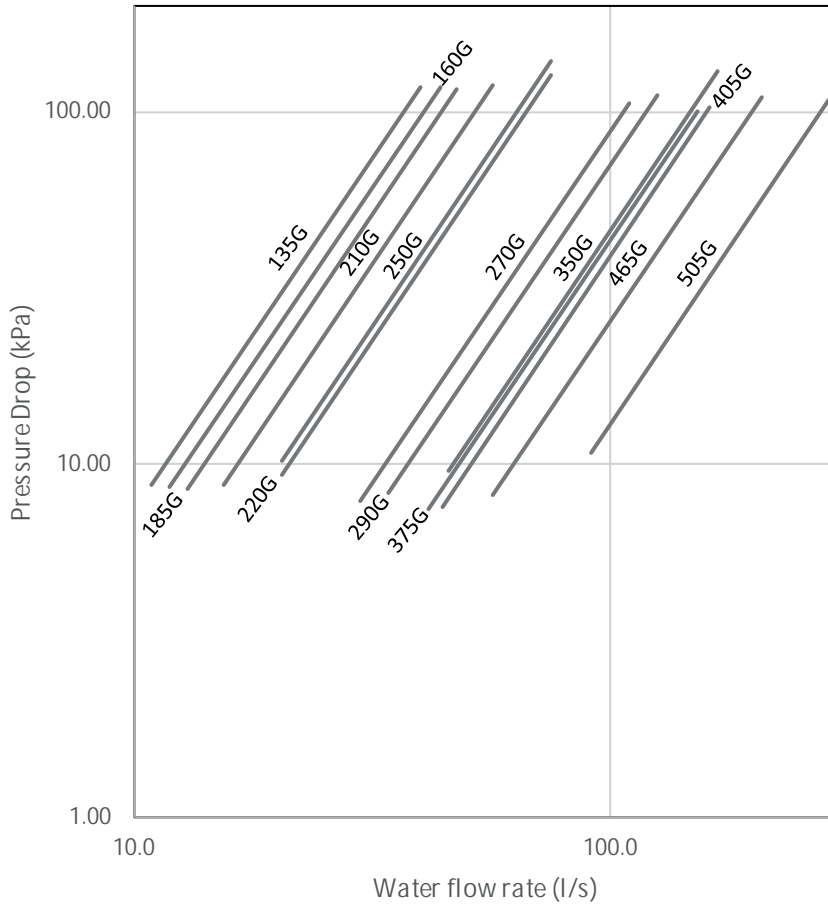

Electrical Data

GVWF

		GVWF 190	GVWF 215	GVWF 260	GVWF 300	GVWF 325	GVWF 390	GVWF 275	GVWF 320	GVWF 370	GVWF 380	GVWF 410	GVWF 420	GVWF 480	GVWF 590	GVWF 515	GVWF 570	GVWF 695	GVWF 760
Max current	(A)	291	377	463	375	400	423	438	524	503	696	675	564	587	632	927	751	796	843
Starting current	(A)	<10	<10	<10	<10	<10	<10	<10	<10	<10	<10	<10	<10	<10	<10	<10	<10	<10	<10

GVWF G

		GVWF 135 G	GVWF 160 G	GVWF 185 G	GVWF 210 G	GVWF 220 G	GVWF 250 G	GVWF 270 G	GVWF 290 G	GVWF 350 G	GVWF 375 G	GVWF 405 G	GVWF 465 G	GVWF 505 G
Max current	(A)	213	272	331	275	296	317	498	414	477	663	551	635	635
Starting current	(A)	<10	<10	<10	<10	<10	<10	<10	<10	<10	<10	<10	<10	<10



Acoustic Data

	At Optimum EER		At Max Capacity	
	Global Sound Power	Global Sound Pressure level at 10m	Global Sound Power	Global Sound Pressure level at 10m
	SWL (dB(A))	SPL (dB(A))	SWL (dB(A))	SPL (dB(A))
GVWF 190	87	55	91	59
GVWF 215	88	56	91	60
GVWF 260	89	57	93	61
GVWF 300	92	60	96	65
GVWF 325	96	64	98	66
GVWF 390	99	67	100	68
GVWF 275	88	56	92	60
GVWF 320	89	57	93	61
GVWF 370	95	63	98	66
GVWF 380	91	59	94	62
GVWF 410	96	64	98	66
GVWF 420	93	61	98	66
GVWF 480	96	64	100	68
GVWF 590	100	69	102	70
GVWF 515	92	60	96	63
GVWF 570	96	64	99	67
GVWF 695	99	67	101	69
GVWF 760	101	69	103	71
GVWF 135 G	86	55	90	58
GVWF 160 G	88	56	91	59
GVWF 185 G	89	57	92	60
GVWF 210 G	92	60	95	63
GVWF 220 G	96	64	96	64
GVWF 250 G	97	66	98	66
GVWF 270 G	90	58	93	61
GVWF 290 G	93	61	96	64
GVWF 350 G	99	67	100	68
GVWF 375 G	91	59	95	63
GVWF 405 G	95	63	98	65
GVWF 465 G	100	68	101	69
GVWF 505 G	101	68	102	70



Notes



Trane optimizes the performance of homes and buildings around the world. A business of Ingersoll Rand, the leader in creating and sustaining safe, comfortable and energy efficient environments, Trane offers a broad portfolio of advanced controls and HVAC systems, comprehensive building services and parts. For more information visit www.Trane.eu

Trane has a policy of continuous product and product data improvement and reserves the right to change design and specifications without notice.

© 2019 Trane All rights reserved
CTV-PRC019C-GB_0119
Supersedes CTV-PRC019B_GB_0218

We are committed to using environmentally
conscious print practices that reduce waste.

