



Water-cooled screw chillers and Water/Water Heat pumps

Refrigerant R1234ze

RTSF 050 G – 110 G (180 to 385 kW)



October 2020

RLC-PRC065C-GB

TRANE
TECHNOLOGIES



Table of Contents

Introduction.....	3
Features and benefits	4
Trane Helical-Rotary Compressors	4
Capacity Control and Load Matching.....	4
High Condensing temperatures applications.....	5
Variable Primary Flow	5
Factory Testing Means Trouble-Free Start-up	5
Factory-Installed and Tested Controls and Options Speed Installation	5
Superior Control with UC 800™ Chiller controls.....	5
SmartFlow control.....	6
System option: Ice storage	6
Product certification	7
Base unit description.....	8
Options description	9
General Data	11
Operating Map.....	12
Evaporator pressure drop.....	13
Condenser pressure drop	13
Pressure drop.....	13
Electrical Data	14
Acoustic Data	15

Introduction

The new **Trane City RTSF G** series is the result of a search for higher reliability and higher energy efficiency, for today's environment.

EcoWise[™]

City RTSF G chillers with **R1234ze** low GWP refrigerants are part of the **EcoWise[™]** portfolio of products that are designed to lower their environmental impact with next-generation, low global warming potential (GWP) refrigerants and high-efficiency operation.

In an effort to reduce energy consumed by cooling and heating equipment and to continually operate, Trane has developed the **City RTSF G** chillers and heat pumps with higher efficiencies and a more reliable design than any other water-to-water equipment available on the market today.

The **City RTSF G** uses the proven design of the Trane helical-rotary compressors, which embraces all of the design features that have made the Trane helical-rotary compressor liquid chillers such a success since 1987.

The industrial-grade design of this helical rotary chillers and heat pumps is ideal for both industrial and commercial markets, in applications such as office buildings, hospitals, schools, retail buildings, and industrial facilities.

The major advantages of the **City RTSF G** are:

- Very low environmental impact thanks to near zero GWP (<1) R1234ze refrigerant.
- High efficiencies both in cooling and heating.
- 99.5% reliability rate.
- Suitable with high condensing temperature and heat pump applications with possible delivery of hot water up to 85°C.
- Great versatility to adapt to varying applications requirements:
 - Comfort cooling or heating
 - High temperature heating up to 80°C
 - Process Cooling down to -12°C
 - Ice storage
- Modularity and scalability to adapt to building or process capacity evolution.



Features and benefits

Trane Helical-Rotary Compressors

- **Unequaled-reliability.** Trane helical-rotary compressor are designed, built, and tested to the same demanding and rugged standards as the previous generation helical-rotary compressors used in both air- and water-cooled chillers for more than 27 years.
- **Years of research and testing.** The Trane helical-rotary compressors have amassed thousands of hours of testing, much of it at severe operating conditions beyond normal commercial air- conditioning applications.
- **Proven track record.** The Trane Company is the world's largest manufacturer of large helical-rotary compressors used for refrigeration. Over 300,000 compressors worldwide have proven that the Trane helical- rotary compressors have a reliability rate of greater than 99.5% in the first year of operation – unequalled in the industry.
- **Resistance to liquid slugging.** The robust design of the Trane Series R™ compressor can ingest amounts of liquid refrigerant that normally would severely damage compressor.
- **Fewer moving parts.** The helical- rotary compressor has only two rotating parts: the male rotor and the female rotor.
- **Direct-drive, low-speed,** semi- hermetic compressor for high efficiency and high reliability.
- **Field-serviceable compressor** for easy maintenance.
- **Suction-gas-cooled motor.** The motor operates at lower temperatures for longer motor life.
- **Five minute** start-to-start and two minute stop-to-start anti-recycle timer allows for closer water-loop temperature control.

Figure 1 – Trane GP2 compressor

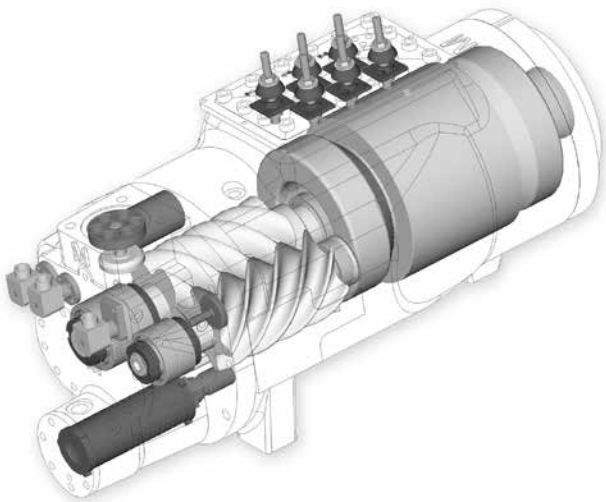

Capacity Control and Load Matching

The combination of patented unloading system on Trane helical- rotary compressors valve plus the Adaptive Frequency™ drive allows exactly matching building load and getting excellent efficiencies at full load and part. This allows the compressor to modulate infinitely, to exactly match building load and to maintain chilled-water supply temperatures within $\pm 0.3^{\circ}\text{C}$ of the set point. Helical-rotary chillers that rely on stepped capacity control must run at a capacity equal to or greater than the load, and typically can only maintain water temperature to around $\pm 1^{\circ}\text{C}$. Much of this excess capacity is lost because overcooling goes toward removing building latent heat, causing the building to be dried beyond normal comfort requirements.

City RTSF G units are fully compliant with Class C3 (Industrial environment) requirements of EN61800-3 standard.

Features and benefits

High Condensing temperatures applications

When considering heat pump or low leaving temperatures industrial process applications, compressor operates under severe pressure conditions, which, if not anticipated may be harmful for compressor or considerably decrease life and reliability of compressor. For high lift applications, **City RTSF G** units, feature a dedicated compressor design to keep up with those harsh operating conditions. Therefore, RTSF G units can reach temperatures as low as -12°C on the evaporator side or as high as 80°C on the condensing side, yet keeping high efficiency and premier reliability.

Variable Primary Flow

An attractive chilled-water system option may be a variable primary flow (VPF) system. VPF systems present building owners with several cost-saving benefits that are directly related to the pumps. The most obvious cost savings result from eliminating the secondary distribution pump, which in turn avoids the expense incurred with the associated piping connections (material, labor), electrical service, and variable-frequency drive.

Building owners often cite pump related energy savings as the reason that prompted them to install a VPF system. With the help of a TRANE software analysis tool, you can determine whether the anticipated energy savings justify the use of variable primary flow in a particular application. It may also be easier to apply variable primary flow in an existing chilled-water plant.

Unlike the “decoupled” design, the bypass can be positioned at various points in the chilled-water loop and an additional pump is unnecessary. The evaporator in the **City** series can withstand up to 50% percent water flow reduction as long as this flow is equal to or above the minimum flow-rate requirements. The microprocessor and capacity control algorithms are designed to handle a maximum of 10% change in water flow rate per minute in order to maintain $\pm 0.3^{\circ}\text{C}$ leaving evaporator temperature control. For applications in which system energy savings is most important and tight temperature control is classified as $\pm 1.1^{\circ}\text{C}$, up to 30% changes in flow per minute are possible.

Factory Testing Means Trouble-Free Start-up

All **City** chillers and heat pumps are given a complete functional test at the factory. This computer-based test program completely checks the sensors, wiring, electrical components, microprocessor function, communication capability, expansion valve performance, and fans. In addition, each compressor is run-tested to verify capacity and efficiency. Where applicable, each unit is factory preset to the customer’s design conditions. An example would be the leaving-liquid temperature set point. The result of this test program is that the chiller arrives at the job site fully tested and ready for operation.

Factory-Installed and Tested Controls and Options Speed Installation

All **City** chillers and Heat pumps options are factory installed and tested. Some manufacturers send accessories in pieces to be field installed. With Trane, the customer saves on installation expense and has assurance that ALL chiller controls and options have been tested and will function as expected.

Superior Control with UC 800™ Chiller controls

The Adaptive Control™ microprocessor system enhances the **City** chiller and heat pumps by providing the very latest control technology. With the Adaptive Control microprocessor, unnecessary service calls and unhappy tenants are avoided. The unit does not nuisance-trip or unnecessarily shut down. Only when the unit controls have exhausted all possible corrective actions and the unit is still violating an operating limit, will the unit shut down. Controls on other equipment typically shut down the unit, usually just when it is needed the most.





Features and benefits

SmartFlow control

City series units are fully compatible with variable flow operation both on evaporator and condenser sides. The modulation of the pump speed is managed to ensure that chiller ΔT stays constant. Entering and leaving temperatures at the evaporator will be measured directly by the chiller controller, through the factory-supplied sensor. A ΔT setpoint will be present on the unit controller. The option for constant ΔT is intended to be used with 3-way valves on water systems, or 2-way valves on water system but constant flow at the by-pass.

System option: Ice storage

UC 800 optimization software controls operation of the required equipment and accessories to easily move from one mode of operation to another. For example: even with ice-storage systems, there are numerous hours when ice is neither produced nor consumed, but saved.

In this mode, the chiller is the sole source of cooling. For example, to cool the building after all ice is produced but before high electrical demand charges take effect, UC 800 sets the chiller leaving- fluid set point to its most efficient setting and starts the chiller, chiller pump, and load pump.

When electrical demand is high, the ice pump is started and the chiller is either demand limited or shut down completely. UC 800 controls have the intelligence to optimally balance the contribution of the ice and the chiller in meeting the cooling load.

The capacity of the chiller plant is extended by operating the chiller and ice in tandem. UC 800 rations the ice, augmenting chiller capacity while reducing cooling costs. When ice is produced, UC 800 will lower the chiller leaving-fluid set point and start the chiller, ice and chiller pumps, and other accessories. Any incidental loads that persist while producing ice can be addressed by starting the load pump and drawing spent cooling fluid from the ice storage tanks.

For specific information on ice storage applications, contact your local sales office.

City has been designed specially to perform in all kind of applications:

Figure 2 – Typical application ranges of Chillers and Heat pumps

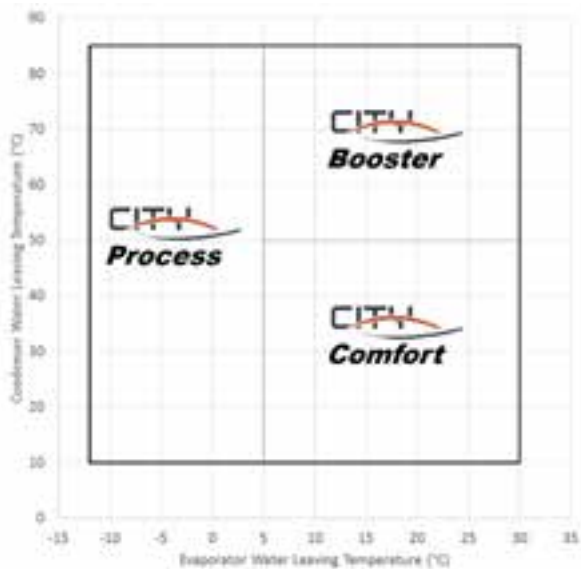

Features and benefits

CITH Comfort

Efficiency optimized for moderate comfort applications in cooling or heating up to 50°C, or industrial process applications at positive temperatures.

CITH Process

Efficiency optimized for freezing industrial process applications.

CITH Booster

Operation and Efficiency optimized to deliver High temperature hot water between 50°C and 80°C.

Product certification

Trane as a Global leader in the HVAC industry participates to Eurovent chillers and heat pump certification programs. Through this third party certifications, Trane commits to deliver units that comply with the declared performance.



Base unit description

RTSF G	
Power supply	400 V - 3 Ph - 50 Hz - Single point
Compressor type	Trane CHHP
Compressor technology	AFD
Number of circuits	1
Compliance	CE - PED
Refrigerant	R1234ze
Relief valve	Single relief valve on condenser
Evaporator water connections	Direct Connection - Grooved pipes
Evaporator water side pressure	10 bars
Condenser water connections	Direct Connection - Grooved pipes
Condenser water side pressure	10 bars
Flow Control	Constant Flow - Pump signal On/Off (Condenser + Evaporator)
Power protection	Fused
Electrical IP protection	IP20
Underover voltage – Phase reversal	Included
Installation accessories	Optional

Options description

Option Description	Application		Factory mounted	Accessory (not fitted)
Condenser application				
High Condenser temperature	Entering condenser temperatures above 50°C	Dedicated Compressor	•	
Water to water HP operation	Condenser Leaving water temperature control	Heat pump applications with Leaving water up to 80°C	•	
Evaporator application				
Process cooling	Leaving Evaporator temperature below 5°C	Dedicated Compressor	•	
Ice making	Dual setpoint (Comfort / Ice making)	Ice storage applications for Ice making temperatures as low as -7°C	•	
Aesthetics				
Enclosed unit	Additional panels	Access to all inside components protected by panels	•	
Acoustics				
Sound reduction	Additional sound proof panels	Sound reduction of up to -9 dB(A)	•	
Electrical				
Power protection	Unit protection by Circuit Breaker	Protection of compressors against over current	•	
Power socket	230 V Power socket	Local Power source to connect an electrical device such as a Laptop	•	
Relief Valve				
Single relief valve on both condenser and evaporator	Additional relief valve on Low pressure side	Additional pressure safety device	•	
Dual Relief valve on condenser only	2 relief valve with by 3 way valve on high pressure side	Maintenance	•	
Dual relief valve on both evaporator and condenser	2 relief valve with by 3 way valve on both high and low side	Maintenance	•	
Additional Insulation				
Condenser insulation	Thermal insulation of Condenser	Limit heat release in plant room	•	
SmartFlow Control				
VPF Constant Delta T Evaporator	Optional PC board delivering a 2-10 V modulating signal output to control a pump motor speed inverter	Evaporator variable speed pump control based on a constant Delta T	•	
VPF Constant Delta T Condenser	Optional PC board delivering a 2-10 V modulating signal output to control a pump motor speed inverter	Condenser variable speed pump control based on a constant Delta T	•	
VPF Constant Delta T Evaporator and Condenser	Optional PC board delivering a 2-10 V modulating signal output to control a pump motor speed inverter	Evaporator and Condenser variable speed pump control based on constant Delta T's	•	
Controls options				
BACnet MSTP interface	Communication card	Communication with BMS through BACnet MSTP Protocol	•	
BACnet IP interface	Communication card	Communication with BMS through BACnet IP Protocol	•	
ModBus RTU interface	Communication card	Communication with BMS through Modbus Protocol	•	
LonTalk Interface	Communication card	Communication with BMS through LonTalk Protocol	•	
External setpoints & capacity outputs	Programmable Input/Output card and sensors	Remote Control or remote monitoring		•
Outdoor Air Temp Sensor	With Outdoor Air Temp Sensor	Measurement of Outdoor ambient air temp to perform water set point offset		•
Master slave operation	Communication card	Operation of two chillers on a same water loop	•	
Condenser Water Control Output	Communication card - 0-10 V Analog output	Allows to control a valve on condenser loop to perform proper unit start when condenser water loop is cold	•	
Condenser Pressure (%HPC) Output	Communication card - 0-10 V Analog output	Allows control of cooling device based on condenser pressure (Ice.Cooling tower fan, 3-Way valve...)	•	
Differential Pressure Output	Communication card - 0-10 V Analog output	Allows control of a 3-way valve on condenser water loop	•	
Power socket	230 V Power socket	Local Power source to connect an electrical device such as a Laptop	•	



Options description

Anti vibration accessories		
Neoprene isolators		Eliminates vibration transmission risk to building •
Neoprene pads		Eliminates vibration transmission risk to building •
Grooved pipe with coupling & pipe stub	4 Grooved pipe adapters	Allows welded connection to unit •
Flow Switch		
Evaporator or Condenser Flow switch	One Flow Switch delivered to be installed either on Evaporator or Condenser side	Allows to check flow detection •
Evaporator and Condenser Flow switch	Two Flow Switches delivered to be installed respectively on Evaporator and Condenser side	Allows to check flow detection •

General Data

Unit size		RTSF 050 G	RTSF 060 G	RTSF 070 G	RTSF 090 G	RTSF 100 G	RTSF 110 G
Cooling Performances							
Net cooling capacity (1) (2)	(kW)	184	220	264	315	362	387
Net EER (1) (2)		5.03	5.10	5.02	4.94	4.55	4.34
Eurovent Energy class - Cooling		B	A	B	B	C	C
SEER (3)		6.70	6.95	7.03	7.48	7.20	6.38
Space cooling efficiency $\eta_{s,c}$ (3)	(%)	265	275	2.78	296	285	252
Heating Performances							
Low Temperature (5)							
Net Heating capacity (2)		216	258	311	372	434	471
Net COP (2)		5.75	5.85	5.73	5.69	5.30	5.10
SCOP (4)		6.62	6.91	6.70	7.13	7.07	6.41
Space heating efficiency $\eta_{s,h}$ (4)	(%)	257	268	260	277	275	249
Air conditioning application (6)							
Net Heating capacity (2)	(kW)	204	243	294	351	410	444
Net COP (2)		4.50	4.59	4.57	4.55	4.34	4.32
Eurovent Energy efficiency class - Heating		A	A	A	A	B	B
High temperature application (7)							
Net Heating capacity (2)	(kW)	182	221	255	308	366	420
Net COP (2)		3.74	3.78	3.92	3.90	3.80	3.68
SCOP (4)		4.82	4.91	5.08	5.09	5.09	5.11
Space heating efficiency $\eta_{s,h}$ (4)		185	188	195	196	196	196
Very High temperature application (8)							
Net Heating capacity (2)	(kW)	171	207	240	288	3.44	3.94
Net COP (2)		3.02	3.05	3.16	3.14	3.09	2.99
Compressor							
Number		1					
Evaporator							
Nominal Flow (1)	l/s	8.8	10.5	12.6	15.0	17.3	18.5
Pressure Drop (1)	kPa	30.4	25.4	35.5	29.6	38.9	43.8
Minimum Flow	l/s	3.6	4.8	4.8	6.4	6.4	6.4
Maximum Flow	l/s	38.6	38.6	38.6	38.6	38.6	38.6
Water Connection Type		Grooved ends					
Water Connection Size	in	4.0					
Condenser							
Nominal Flow (1)	l/s	10.5	12.5	15.1	18.0	21.1	22.8
Pressure Drop (1)	kPa	38.7	53.9	41.1	57.1	77.1	88.4
Minimum Flow	l/s	1.9	1.9	2.7	2.7	2.7	2.7
Maximum Flow	l/s	38.6	38.6	38.6	38.6	38.6	38.6
Water Connection Type		Grooved ends					
Water Connection Size	in	4.0					
Refrigerant							
Type		R1234ze					
Charge	(kg)	31	34	42	47	47	47
Weights and dimensions (10)							
Length	(mm)	2240	2240	2240	2240	2240	2240
Width	(mm)	900	900	900	900	900	900
Height	(mm)	1940	1940	1960	1960	1960	1960
Operating Weight	(kg)	1690	1770	2020	2130	2130	2130

(1) Evaporator 12/7°C and 0.0 m²K/kW, and condenser at 30/35°C and 0.0 m²K/kW.

(2) Net performances calculated as per EN 14511-2013.

(3) $\eta_{s,c}$ / SEER as defined in Directive 2009/125/EC of the European Parliament and of the Council with regard to Ecodesign requirements for Comfort Chillers with 2000 kW maximum capacity - COMMISSION REGULATION (EU) N° 2016/2281 of 20 December 2016.

(4) $\eta_{s,h}$ / SCOP as defined in Directive 2009/125/EC of the European Parliament and of the Council with regard to Ecodesign requirements for space heaters with 400 kW maximum rated capacity - COMMISSION REGULATION (EU) N° 813/2013/EU of 2 August 2013.

(5) At 10/7°C Entering/Leaving evaporator and 30/35°C Entering/Leaving condenser.

(6) At 10/7°C Entering/Leaving evaporator and 40/45°C Entering/Leaving condenser.

(7) At 10/7°C Entering/Leaving evaporator and 47/55°C Entering/Leaving condenser.

(8) At 10/7°C Entering/Leaving evaporator and 55/65°C Entering/Leaving condenser.

(9) At full load and in accordance with ISO9614.

(10) For base units without panels.

Operating Map

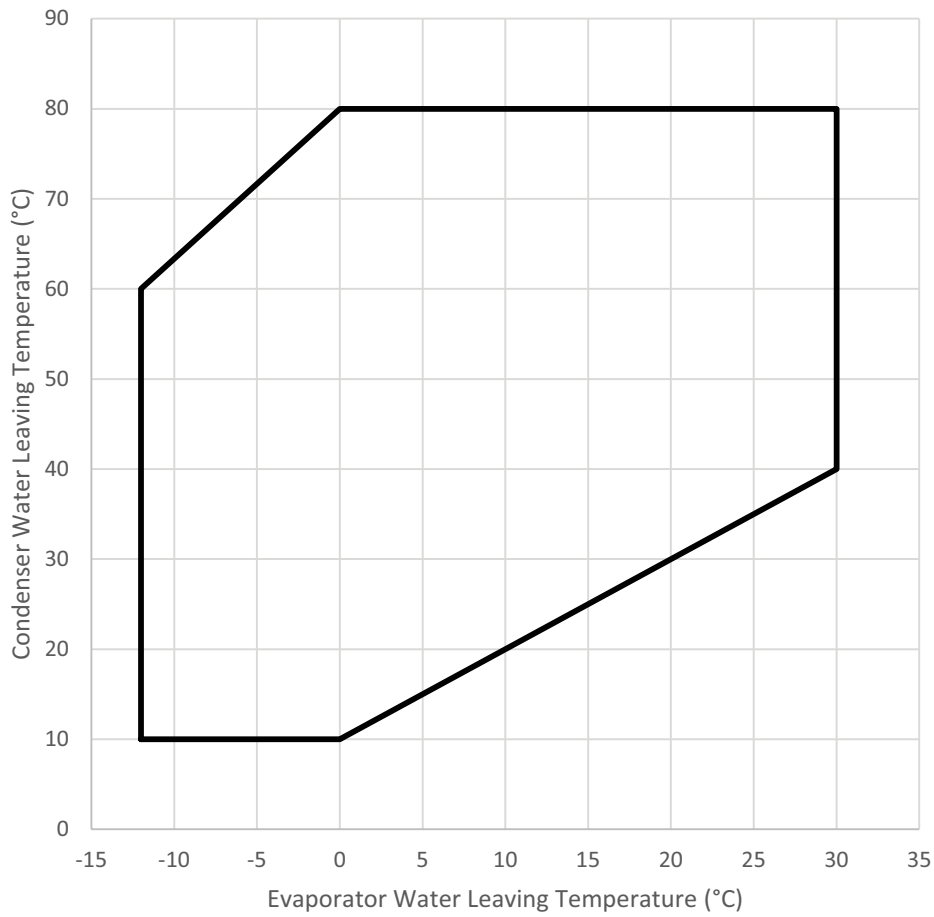

Pressure drop

Evaporator pressure drop

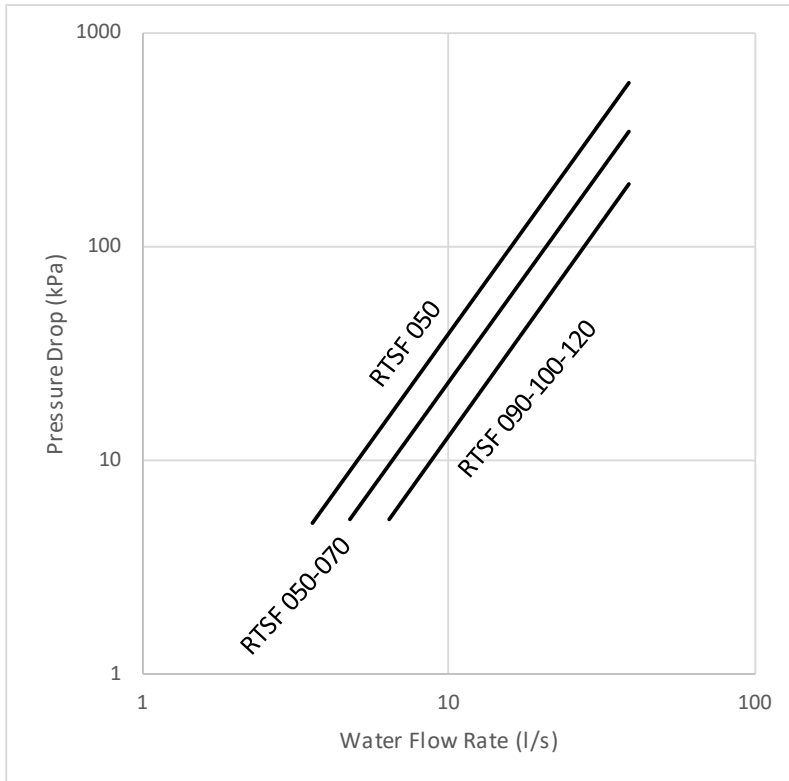

Condenser pressure drop

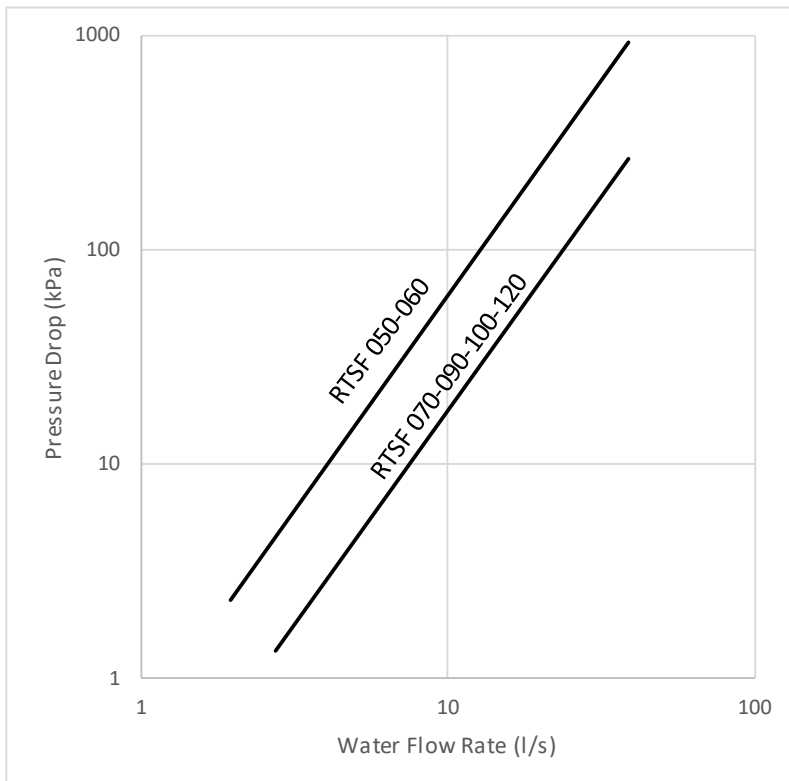



Electrical Data

			RTSF 050 G	RTSF 060 G	RTSF 070 G	RTSF 090 G	RTSF 100 G	RTSF 110 G
Comfort Cooling	Max current	(A)	102	118	140	169	206	281
Comfort Heating	Starting current	(A)	102	118	140	169	206	281
Process Cooling	Max current	(A)	136	160	193	230	281	281
Very High Temp Heating	Starting current	(A)	136	160	193	230	281	281

Acoustic Data

		RTSF 050 G	RTSF 060 G	RTSF 070 G	RTSF 080 G	RTSF 090 G	RTSF 100 G	RTSF 110 G
Global Sound Power SWL	(dB(A))	93	93	98	98	98	98	94
Global Sound pressure level at 3 m SPL	(dB(A))	70	70	75	75	75	75	71
Global Sound pressure level at 10 m SPL	(dB(A))	61	61	66	66	66	66	62
Global Sound Power with sound enclosure SWL	(dB(A))	84	84	89	89	89	89	87
Global Sound pressure level with sound enclosure at 3 m SPL	(dB(A))	61	61	66	66	66	66	64
Global Sound pressure level with sound enclosure at 10 m SPL	(dB(A))	52	52	57	57	57	57	55

Trane - by Trane Technologies (NYSE: TT), a global climate innovator - creates comfortable, energy efficient indoor environments for commercial and residential applications. For more information, please visit trane.com or tranetechnologies.com.

Trane has a policy of continuous product and product data improvement and reserves the right to change design and specifications without notice. We are committed to using environmentally conscious print practices.

RLC-PRC065C-GB (October 2020)
Supersedes RLC-PRC065B-GB (April 2020)

© 2020 Trane

Confidential and proprietary Trane information