



Product Catalogue

Solution Plus

Split System - Double Wall - 5 to 50 Ton Coil and Fan Modules

Forward-Curved and Backward-Curved Fans
with Cond. Unit TRAE - Axial Fan

with Cond. Unit TRCE - Centrifugal Fan

Condensing Unit - TRAE

Condensing Unit - TRCE

60 Hz





Introduction

IMPORTANT:
Dimensional measuring units on
this catalog are on millimetres (mm).
(Except for those locally referenced).

Refrigerant Emission Control

Gas conservation and emission reduction should be accomplished by adhering to operational and service procedures recommended by Trane, with special attention to the following:

The refrigerant used in any type of AC equipment must be always recovered and/or recycled for reuse, reclaimed or completely destroyed after being removed from the unit.

Never release the refrigerant to the atmosphere.

Always consider the possibility of recycling or reprocessing the refrigerant before starting the reclaim process by any method.

The ARI 700 Standard covers questions about recovered refrigerant and acceptable quality.

Use only approved and safe cylinders. All applicable safety and shipping standards must be met during the transportation of refrigerant containers.

Recycling equipment should be used to minimize emissions during the transfer of refrigerant gas. Always use methods that generate the lowest possible vacuum during the recovery and condensation of refrigerant into the cylinder.

Important:

Trane has a policy of continuous product development and reserves the right to change design and specifications without notice. Only qualified technicians or technicians authorized by Trane should perform the installation and servicing of equipment referred to in this publication. Failure to comply with and/or adhere to the procedures in this manual may void the product warranty.

Contents

Introduction	2
I-General Information	4
II-Model Description	12
III-General Data	15
IV-Coil Module	18
V-Air Filters	20
VI-Cooling Capacities	22
VII-Fan Performance and Transmission Option	34
VIII - Electrical Characteristics	47
IX-Electrical Diagrams	69
X-Dimensional	71
XI-Controls	98
XII-Mechanical Specification	99
XIII-Weights	104
XIV-Conversion Table	105

I-General Information

Solution Plus Solution in Split Systems

Developed to serve industrial and commercial markets. All the Solution Plus models have been designed to provide easy installation and maintenances

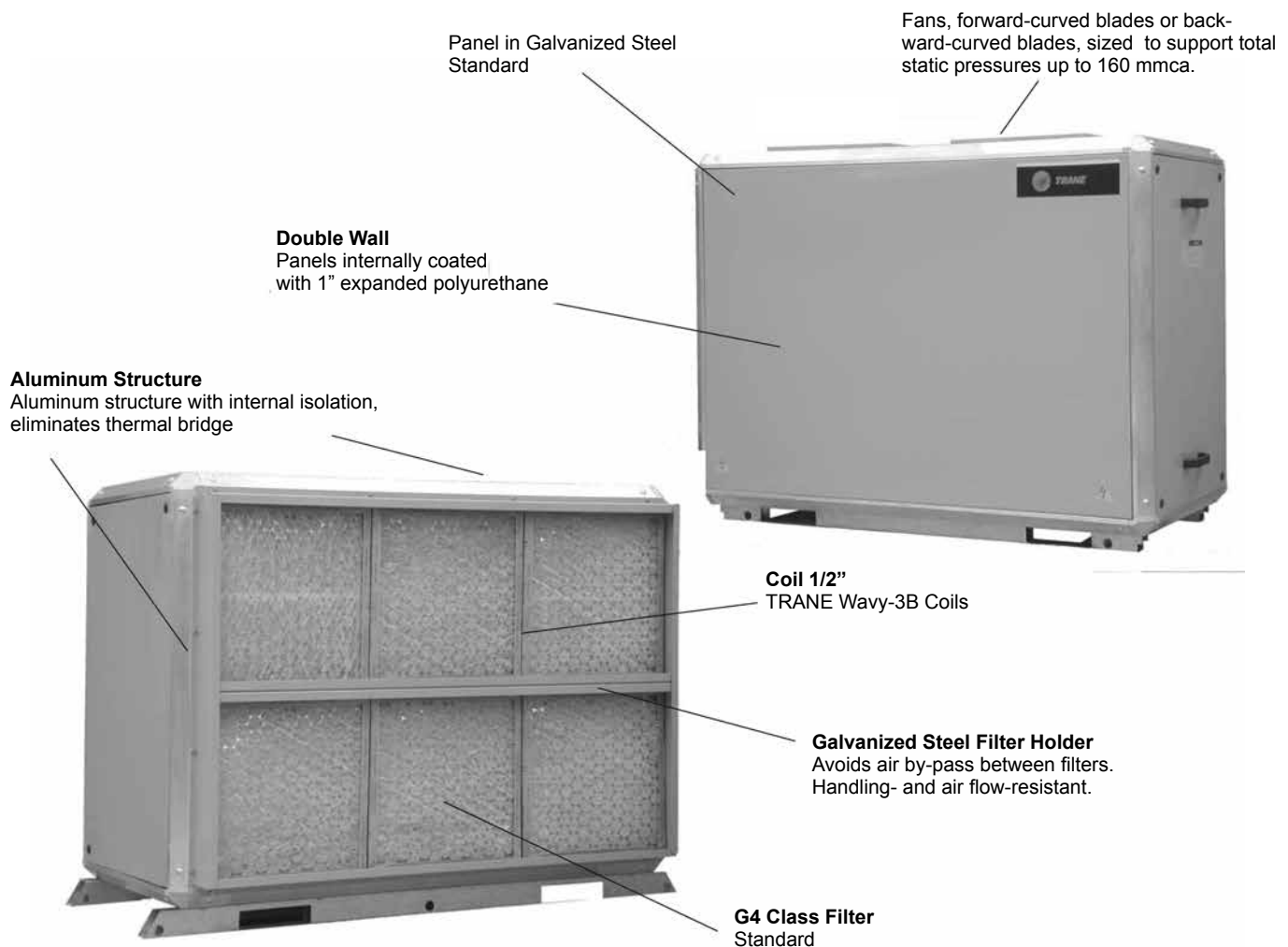

General Information

Solution Plus Condensing Unit TRAE

Capacity from 5 to 25 Ton.
Scroll Compressor. Horizontal air discharge - 5 to 15 Ton and Vertical 20 to 25 Ton. Axial Fan. Cabinet in galvanized steel sheet, with electrostatic powdered painting.

Panel in Galvanized Steel Standard

Horizontal Discharge
For 5 to 15 Ton models,
axial-type fan.

Vertical Discharge
For 20 to 25 Ton models, axial-type fan.

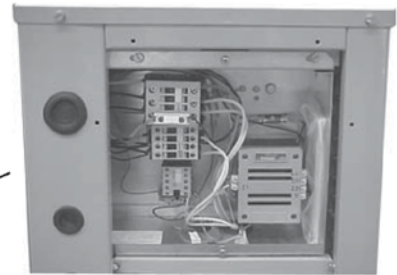

Inbuilt Electrical Panel
Unit electrical panel embedded in the structure.



Easy Installation
TRAE condensing units are easy to install.



General Information

Condensing Unit TRCE

Capacity from 5 15 Ton. Air remote
Condenser. Scroll Compressor.
Horizontal/Vertical air discharge - 5
to 15 Ton. Centrifugal Fan. Cabinet
in galvanized steel sheet, with
electrostatic powdered painting.



General Information

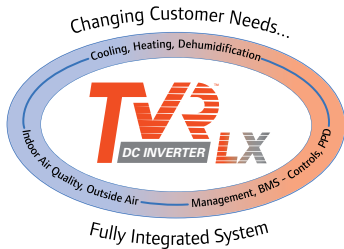

TVR LX Condensing Unit

Capacity from 5 to 70 TON (capacity according to the 34 combinations of modulations available). DC inverter scroll compressor. Vertical air discharge. Axial fan with DC motor. Wide cooling and heating operating range. Enhanced maintainability; new design of the rotary control panel for easy maintenance of the condensing unit.

Equipment fitted with components designed to improve energy efficiency, low noise and assemblies flexibilities.



4TVH0086-115

4TVH00140-210



4TVH0229-420



4TVH0438-629



4TVH0648-840

TVR LX combinations	-	1 MODULE								
		kW	25,2	28,1	33,7	41,0	45,4	49,8	56,3	61,5
		MBtu/h	86	96	115	140	155	170	192	210
TON	7,2	8,0	9,6	11,7	12,9	14,2	16,0	17,5		
4TVH0086DE(6)0	X									
4TVH0096DE(6)0			X							
4TVH0115DE(6)0				X						
4TVH0140DE(6)0					X					
4TVH0155DE(6)0						X				
4TVH0170DE(6)0							X			
4TVH0192DE(6)0								X		
4TVH0210DE(6)0									X	
Quantity Maximum Evaporator		13	16	20	23	26	29	33	36	

Note: For installation information consult the catalog VRFDX-SLB001-PB of TVR LX + Solution Plus.

General Information

Solution Plus

The main benefits of the **Solution Plus** line are:

Fast Cycle, is an option with configuration standard offering quick production time.

- **Modular Units**, factory-predefined by Client, for vertical or horizontal assembly, with many discharge options. The units are placed on galvanized steel “U” rails, which provide easy hoisting and work as a support.

- **O Solution Plus with Condensing Unit TRCE has 8 Models**, with capacities ranging from 5 to 30 Ton, and air flows from 2.000 to 25.000 m³/h.

- **Solution Plus with TVR LX** condensing unit features combinations ranging from 5 to 50 TR and air flow rates ranging from 2,000 to 40,000 m³/h.

- **Solution Plus with Condensing Unit TRAE has 11 Models**, with capacities ranging from 5 to 50 Ton, and air flows from 2.000 to 40.000 m³/h.

- **Double Wall**, the steel panels in coil and fan models are internally isolated with 25-mm expanded polyurethane.

- **Down Flow Discharge Option**, the coil and fan module set has several discharge options, including the down flow discharge, offering more versatility to your job.

- **High-efficiency TRANE Wavy-3B Coils**, the coil is built with seamless copper tubes. The copper tubes are mechanically expanded on the aluminum fins for perfect contact between fins and tubes.

- **Aluminum Structure**, the coil and fan modules have polished, laminated aluminum structure, with internal thermoinsulating coating so as to eliminate thermal bridge.

- **Several Filtering Options**, simple or double filtration, with permanent or throwaway filters.

- **Evaporator Unit with 2- or 4-pole motors**, 60 Hz (IP21 and IP55), with regulating sheave.

- **Fans**, with forward-curved blades or backward-curved blades, sized to support a total static pressure of up to 160 mmca.

- **Open Air Modules**, cabinets prepared for outdoor operation.

Precautions against product corrosion In need of installing air conditioning equipment in these areas, Trane recommends the application of extra protection against corrosion, such as Phenolic protection or the application of ADSIL®.

For more information, contact your local distributor.

General Information

Solution Plus with TRAE Axial Fan

Module



Coil Module



Fan Module

Condensing Units



TRAE 5 to 10 TON
Horizontal Discharge



TRAE 15 TON
Horizontal Discharge



TRAE 20 to 25 Ton
Vertical Discharge

Coil Module

This module consists of filter, cooling coil, expansion valve and draining tray. Alternatively, it can be supplied with heating resistances. This module has three frames for installation of up to three 1" filters in each frame.

Fan Module

It consists of forward curved blades or backward curved blades fan (Backward-Curved), driving motor, regulating motor sheave, fan sheave and belts. The fan module has several air discharge options. It has a canvas collar to provide easier installation for air intake and return air ducts. Collar width ranges from 120 to 370 mm, depending on the model.

Mixing Box Module (Optional)

The mixing box is always mounted before the coil module. The mixing box is a box where air intake and return air ducts can be installed. The mixing box module has galvanized steel dampers, with opposite blades and manual or automatic driving axis for air regulation using dampers. When **Solution Plus** is assembled with a mixing box, filters are incorporated to the box. Both sides of the box have caps to provide easy access to the filters.

Final Module Filter

This module is an option for installations that require a better air treatment.

Positioned after the fan module and the module serpentine this option makes it possible to use fine filter (type pouch) and Absolute (H. E. P. A). Filters of this type should be allocated in this module because the depth of the filters do not allows to be used in another module.

Return filter module

To the treatment of the return air there is this option of cabinet. Ditto the module final filter, the return module is used to receive filters with bigger depth (Bag F8).

Empty module

Cabinet with the same characteristics of other modules (see descriptive of cabinet). Used for installation of accessories in the field (attenuator noise, humidifier, electric heater, etc).

Condensing Unit TRAE

Condensing units TRAE are equipped with Scroll-type compressors, and offer horizontal discharge for 5 to 15 Ton models, and vertical discharge for over 20 Ton models. The structure is in galvanized steel and it is painted. Coils are built with Wavy-3B model aluminum fins, with 3/8" internally-ripped copper tube, mechanically expanded in the fins.

Solution Plus

Tab. I-01 - Solution Plus with condensing unit TRAE - available combinations

MODELS	Nominal Capacity (TR)	Set	
		Condensing unit	
		TRCE	TRAE
DXPA05 - 1 circ.	5	TRCE050	TRAE050
DXPA07 - 1 circ.	7,5	TRCE075	TRAE075
DXPA10 - 2 circ.	10	TRCE100 or 2 x TRCE050	TRAE100 or 2 x TRAE050
DXPA12 - 2 circ.	12,5	TRCE050 + TRCE075	TRAE050 + TRAE075
DXPA15 - 2 circ.	15	TRCE150 or 2 x TRCE075	TRAE150 or 2 x TRAE075
DXPA20 - 2 circ.	20	2 x TRCE100	TRAE200 or 2 x TRAE100
DXPA25 - 2 circ.	25	TRCE150 + TRCE100	TRAE250
DXPA30 - 2 circ.	30	2 x TRCE150	2 x TRAE150
DXPA35 - 2 circ.	35	without option	TRAE150 + TRAE200
DXPA40 - 2 circ.	40	without option	TRAE200 + TRAE200
DXPA50 - 2 circ.	50	without option	TRAE250 + TRAE250

**The mixing box module is supplied as an option, and the set code can be either DXTA or DLTA.

General Information

Solution Plus with TRCE Centrifugal Fan

Module



Coil Module



Fan Module

Condensing Units



TRCE 5 to 7,5 TON
Horizontal Discharge



TRCE 10 to 15 TON
Horizontal Discharge

Solution Plus is a split system, designed and planned to satisfy the most demanding markets, joining installation versatility, easy maintenance and low cost. **Solution Plus** is composed by:

- Coil Module
- Fan Module
- Mix Box Module (optional)
- Condensing Unit (TRCE)

Coil Module

This module consists of filter, cooling coil, expansion valve and draining tray. Alternatively, it can be supplied with heating resistances. This module has three frames for installation of up to three 1" filters in each frame.

Fan Module

It consists of forward curved blades or backward curved blades fan (Backward-Curved), driving motor, regulating motor sheave, fan sheave and belts. The fan module has several air discharge options. It has a canvas collar to provide easier installation for air intake and return air ducts. Collar width ranges from 120 to 370 mm, depending on the model.

Mixing Box Module (Optional)

The mixing box is always mounted before the coil module. The mixing box is a box where air intake and return air ducts can be installed. The mixing box module has galvanized steel dampers, with opposite blades and manual or automatic driving axis for air regulation using dampers. When **Solution Plus** is assembled with a mixing box, filters are incorporated to the box. Both sides of the box have caps to provide easy access to the filters.

Solution Plus

Tab. I-02 - Possible matches for Plus with TRCE

MODELS	Nominal Capacity (TR)	Set	
		Condensing unit	
		TRCE	TRAE
DXPA05 - 1 circ.	5	TRCE050	TRAE050
DXPA07 - 1 circ.	7,5	TRCE075	TRAE075
DXPA10 - 2 circ.	10	TRCE100 or 2 x TRCE050	TRAE100 or 2 x TRAE050
DXPA12 - 2 circ.	12,5	TRCE050 + TRCE075	TRAE050 + TRAE075
DXPA15 - 2 circ.	15	TRCE150 or 2 x TRCE075	TRAE150 or 2 x TRAE075
DXPA20 - 2 circ.	20	2 x TRCE100	TRAE200 or 2 x TRAE100
DXPA25 - 2 circ.	25	TRCE150 + TRCE100	TRAE250
DXPA30 - 2 circ.	30	2 x TRCE150	2 x TRAE150
DXPA35 - 2 circ.	35	without option	TRAE150 + TRAE200
DXPA40 - 2 circ.	40	without option	TRAE200 + TRAE200
DXPA50 - 2 circ.	50	without option	TRAE250 + TRAE250

** Mix box module is optional and set code should be DXTA or DLTA.

Final Module Filter

This module is an option for installations that require a better air treatment. Positioned after the fan module and the module serpentine this option makes it possible to use fine filter (type pouch) and Absolute (H. E. P. A). Filters of this type should be allocated in this module because the depth of the filters do not allow to be used in another module.

Return filter module

To the treatment of the return air there is this option of cabinet. Ditto the module final filter, the return module is used to receive filters with bigger depth (Bag F8).

Empty module

Cabinet with the same characteristics of other modules (see descriptive of cabinet). It is a empty module that is used for installation of accessories in the field (attenuator noise, humidifier, electric heater, etc).

Condensing Unit TRCE

The Condensing units TRCE consists basically in 2 modules (heat exchanger and fan), equipped with Scroll compressor, 3 possible discharges options. The structure is in galvanized steel sheet, with recives painting. The condensing coils using the new technology called "Micro-channel" (MCHX), consisting of three main components: tube Micro-Channel plates having a plan, fins located between alternating layers of two types of tubes and manifolds. All components made of aluminium.

General Information

TVR LX

Module



Coil Module



Fan Module

Condensing Units



4TVH0086-115



4TVH00140-210

Solution Plus is a split system, designed and planned to satisfy the most demanding markets, joining installation versatility, easy maintenance and low cost.

Coil Module

This module consists of filter, cooling coil, expansion valve and draining tray. Alternatively, it can be supplied with heating resistances. This module has three frames for installation of up to three 1" filters in each frame.

Fan Module

It consists of forward curved blades or backward curved blades fan (Backward-Curved), driving motor, regulating motor sheave, fan sheave and belts. The fan module has several air discharge options. It has a canvas collar to provide easier installation for air intake and return air ducts. Collar width ranges from 120 to 370 mm, depending on the model.

Mixing Box Module (Optional)

The mixing box is always mounted before the coil module. The mixing box is a box where air intake and return air ducts can be installed. The mixing box module has galvanized steel dampers, with opposite blades and manual or automatic driving axis for air regulation using dampers. When **Solution Plus** is assembled with a mixing box, filters are incorporated to the box. Both sides of the box have caps to provide easy access to the filters.

Final Module Filter

This module is an option for installations that require a better air treatment.

Positioned after the fan module and the module serpentine this option makes it possible to use fine filter (type pouch) and Absolute (H. E. P. A).

Filters of this type should be allocated in this module because the depth of the filters do not allow to be used in another module.

Return filter module

To the treatment of the return air there is this option of cabinet. Ditto the module final filter, the return module is used to receive filters with bigger depth (Bag F8).

Empty module

Cabinet with the same characteristics of other modules (see descriptive of cabinet). It is a empty module that is used for installation of accessories in the field (attenuator noise, humidifier, electric heater, etc).

TVR LX Condensing Unit

The TVR LX condensing units are TRANE's new line of condensers. This is a new product which represents a quantum leap in efficiency and innovation. This is achieved through the use of an optimized fan design with a DC fan motor, an enhanced high-performance heat exchanger, inverter scroll compressors and intelligent defrosting. It features 8 different modules which may operate individually or in a master-slave configuration up to 4 units.

Tab. I-03 - TVR LX - possible combinations Solution Plus with TVR LX.

Set				
MODELS	Nominal Capacity (TON)	Condensing unit TVR LX		
DX05 1C	5 TON	4TVH0086DE(6)0	1 module	
DX07 1C	7,5 TON	4TVH0086DE(6)0		
DX10 2C	10 TON	4TVH0115DE(6)0		
DX12 2C	12,5 TON	4TVH0155DE(6)0		
DX15 2C	15 TON	4TVH0170DE(6)0		
DX20 2C	20 TON	4TVH0249DE(6)0 (4TVH0155DE(6)0 + 4TVH0096DE(6)0)		2 module
DX25 2C	25 TON	4TVH0305DE(6)0 (4TVH0210DE(6)0 + 4TVH0096DE(6)0)		
DX30 2C	30 TON	4TVH0363DE(6)0 (4TVH0210DE(6)0 + 4TVH0155DE(6)0)		
DX35 2C	35 TON	4TVH0420DE(6)0 (2x4TVH0210DE(6)0)		3 module
DX40 2C	40 TON	4TVH0476DE(6)0 (4TVH0210DE(6)0 + 4TVH0170DE(6)0 + 4TVH0096DE(6)0)		
DX50 2C	50 TON	4TVH0590DE(6)0 (2x4TVH0210DE(6)0 + 4TVH0170DE(6)0)		

**The other modules are optionally provided and codes sets verify the page description of the model.

II-Model Description

GENERAL					FAN MODULE			FILTERS			COIL			Kit's Factory			CONTROLS					OPTIONAL		S/E																						
D	X	P	A	1	4	A	A	A	D	3	0	E	B	0	0	B	0	0	B	4	D	2	B	A	0	0	0	0	B	1	0	0	A	0	0	A	0	0	0	0	0	1	1	1	B	0
1	2	3	4	5	6	7	8	9	10	11	12	13	14	15	16	17	18	19	20	21	22	23	24	25	26	27	28	29	30	31	32	33	34	35	36	37	38	39	40	41	42	43	44	45	46	47

Digits 1,2 - General	Digit 8 - General	Digit 13 - Fan Module	Digit 17 - Air Filters	Digit 22 - Coil - Interconnection
Model (Direct Exp.)	Service Digit	Motor Power	Return - Coil Module	Condensing Units
DX = Wave Doble DX (Forward-Curved)	C = Digit C	0 = Not Applicable	0 = Without Filters or Not applicable	0 = Not Applicable
DL = Wave Doble DL (Backward-Curved)		A = 0,5 CV	A = G1 Metalic 1"	A = TRAE (except TRAE250 new cabinet)
	Digit 9 - General	B = 0,75 CV	B = G4 Throwaway 1" - Std	B = TRAE250 (new cabinet)
Digit 3 - General	Cabinet Configuration / Fan Discharge	C = 1,0 CV	D = F5 Pleat 2"	C = TRCE (All)
Modules Configuration	0 = Not Applicable	D = 1,5 CV	E = F8 Plan 3"	D = TVR LX (All)
S = Coil module	A = Vertical / Vertical	E = 2,0 CV	F = F8 Bag **	
V = Fan Module	B = Vertical / Horizontal	F = 3,0 CV	G = A + B	Digit 23 - Coil
M = Mixing Box Module - Standard	C = Vertical / Downflow	G = 4,0 CV	Y = B + D	0 = Reserved
E = Mixing Box Module - without Dampers	D = Horizontal / Horizontal	H = 5,0 CV / (5,5 CV only 50Hz)	K = B + E	Digit 24 - Coil
F = Return Filter Module	E = Horizontal / Vertical	Y = 6 CV	M = B + F **	Drain connection
G = Final Filter Module	F = Horizontal / Downflow	J = 7,5 CV	** Required Return Filter Module	0 = Not Applicable
N = Empty Module		K = 10,0 CV	Digit 18 - Air filters	B = BSP
P = S + V	Digit 10 - General	L = 12,5 CV	Final Filter Module	N = NPT
T = S + V + M	Connections (Frig / Drain)	M = 15,0 CV	0 = Without Filters or Not applicable	
Q = S + V + E	0 = Not Applicable	N = 20,0 CV	1 = F8 Bag Filter	Digit 25 - Coil
R = S + V + F	D = Right Side	P = 25,0 CV	5 = F8 + Absolute Filter A3	Type
D = S + V + G	E = Left Side	Q = 30,0 CV		0 = Not Applicable
J = S + V + E + G		R = 40,0 CV	Digit 19 - Air Filter	A = Standard
K = S + V + M + G	Digit 11 - GERAL		0 = Reserved	Y = Yellow Fin
U = S + V + F + G	Voltage	Digit 14 - Fan Module	Digit 20 - Coil	
	0 = Not Applicable	Transmission Option (NEW)	Number of circuits	
Digit 4 - General	3 = 220V / 60 Hz	0 = Not Applicable	0 = Not Applicable	
Design Sequence	K = 380V / 60 Hz	Specific table for each unit	1 = 1 circuit	
A = Sequence A	4 = 440V / 60 Hz		2 = 2 circuits	
	H = 380V / 50 Hz	Digit 15 - Fan Module	Digit 21 - Coil	
Digits 5,6 - General		0 = Reserved	Refrigerant	
Unit Size	Digit 12 - Auxiliary		0 = Not Applicable	
05 = 05TR	Factory Assembling	Digit 16 - Fan Module	4 = R407C	
07 = 07TR	S = Coil module	0 = Reserved	6 = R410A	
10 = 10TR	V = Fan Module			
12 = 12TR	M = Mixing Box Module - Standard			
15 = 15TR	E = Mixing Box Module - without Dampers			
20 = 20TR	F = Return Air Filter Module			
25 = 25TR	G = Final Filter Module			
30 = 30TR	N = Empty Module			
35 = 35TR	P = S + V			
40 = 40TR	T = S + V + M			
50 = 50TR	Q = S + V + E			
	R = S + V + F			
Digit 7 - General	D = S + V + G			
Design Sequence (Minor Changes)	J = S + V + E + G			
A = Sequence A	K = S + V + M + G			
	U = S + V + F + G			

Model Description

GENERAL								FAN MODULE				FILTERS				COIL				Kit's Factory				CONTROLS								OPTIONAL			S/E													
D	X	P	A	1	4	A	A	A	D	3	0	E	B	0	0	B	0	0	B	4	D	2	B	A	0	0	0	0	B	1	0	0	A	0	0	A	0	0	0	0	0	0	0	1	1	1	B	0
1	2	3	4	5	6	7	8	9	10	11	12	13	14	15	16	17	18	19	20	21	22	23	24	25	26	27	28	29	30	31	32	33	34	35	36	37	38	39	40	41	42	43	44	45	46	47		

Digit 26 - Factory Kits	Digit 30 - Controls	Digit 36 - Controls	Digit 42 - Optional	Digit 46 - Optional - Others
Heating	Starter Type	Thermostat	Power Factor	0 = Without Optional or Not Applicable
0 = Without heat or not applicable	0 = Not Applicable	0 = Not Applicable	0 = Not Applicable	A = Package
A = 1 x 3,0 Kw Electric	1 = X-Type Starter	A = Standard Therm. (Only Cooling)	1 = Capacitor	B = Internal Gasket Option (IGO)
B = 1 x 4,5 Kw Electric		B = Standard Therm. (or sensor)		C = Weather protection
D = 1 x 7,5 Kw Electric	Digit 31 - Controls	(Heating or Cooling)	Digit 43 - Optional	D = A + B
G = 2 x 3,0 Kw Electric	0 = Reserved	C = Programmable Therm. (or sensor)	Fan Motor - Options	E = A + C
H = 2 x 4,5 Kw Electric		(Heating or Cooling)	0 = Not Applicable / STD	F = B + C
Y = 2 x 6,0 Kw Electric	Digit 32 - Controls		1 = W22 Premium Efficiency	G = A + B + C
J = 2 x 7,5 Kw Electric	Electrical Panels	Digit 37 - Controls	3 = W22 Premium Efficiency IPW55	* Weather protection by SPE for:
K = 2 x 9,0 Kw Electric	0 = Not Applicable	0 = Not Applicable		Return Filter and Empty Modules
M = 2 x 15,0 Kw Electric	A = Standard (control voltage 220V)	B = Liquid Sight Glass	Digit 44 - Optional	* Final Filter doesn't accept weather protection
P = 2 x 24,0 Kw Electric	B = Heating		Fan module	
Digit 27 - Factory Kits	D = Standard (control voltage 220V) + Heating	Digit 38 - Controls	0 = Without Optional or Not Applicable	Digit 47 - Product
Humidification	* Fan module - panel is mandatory	Air Pressure Switch	1 = NTN Bearing + Rubber Coupling	0 = STD
0 = Without humidification or not applicable		0 = Without pressure switch or Not ap	2 = Epoxi Coated Fan	Z = SPECIAL
A = 1,5 kg/h (1,12 kW)*	Digit 33 - Controls	A = Diferential Pressure Switch (Fan)	3 = NTN Bearing + Rubber Coupling + Epoxi	F = FAST CYCLE
B = 3,0 kg/h (2,25 Kw) *	Electrical Panel From the Condenser Unit	B = Clogged Filter Switch	Digit 45 - Optional	
C = 5,0 kg/h (3,75 Kw) *	0 = Not Applicable	C = A + B	Coil module	
D = 8,0 kg/h (6,0 Kw) *	A = Standard		0 = Without Optional or Not Applicable	
E = 10,0 kg/h (7,5 Kw) *	B = ReliaTel Microprocessor (RTRM)*	Digit 39 - Controls	1 = Inox Tray	
F = 15,0 kg/h (11,25 Kw) *	* The cond. must be prepared for RTRM	0 = Reserved		
G = 25,0 kg/h (18,75 Kw) *				
* Options that already include	Digit 34 - Controls	Digit 40 - Controls		
electrical panel.	Damper	0 = Reserved		
	0 = Not Applicable			
Digit 28 - Factory Kits	3 = Manual Damper	Digit 41 - Unit destination		
0 = Reserved	4 = Damper prepared for motorized actuation	L = Local market		
		E = Export		
Digit 29 - Factory Kits	Digit 35 - Controls			
0 = Reserved	0 = Reserved			

Model Description

GENERAL										FILTER		COIL			CIRC.		OPTIONAL										S/E											
T	R	A	E	0	5	0	A	0	0	3	A	0	0	1	2	0	A	0	0	0	0	0	0	0	0	0	0	0	0	0	0	0	0	0	0	0	0	0
1	2	3	4	5	6	7	8	9	10	11	12	13	14	15	16	17	18	19	20	21	22	23	24	25	26	27	28	29	30	31	32	33						

Digits 1,2 e 3 - General

Model Unit
 TRA = **Condensing** TRA (Axial Fan)
 TRC = **Condensing** TRC (Centrifugal Fan)

Digit 4 - General

Sequência de Desenvolvimento
 E = Digit E

Digits 5, 6 e 7 - General

Capacity
 050 = 5 TR
 075 = 7.5 TR
 100 = 10 TR
 150 = 15 TR
 200 = 20 TR - (TRA)
 250 = 25 TR - (TRA)

Digit 8 - General

Service Digit
 B = **DIGIT** "B"
 C = **DIGIT** "C" (MCHX > TRC)
 D = **DIGIT** "D" Comp. Danfoss
 E = **DIGIT** "E" Change line Schneider
 F = Change Cabinet TRAE200/250
 G = **Compressors** R410a (DSH)

Digit 9 - General

Evaporator Unit
 0 = Split System (Onix/Solution Plus)

Digit 10 - General

Tension
 3 = 220V / 60 Hz / 3F
 K = 380V / 60 Hz / 3F
 4 = 440V / 60 Hz / 3F
 H = 380V / 50 Hz / 3F

Digit 11 - General

Electrical Panel (NOTA 1)
 A = Standard
 B = RTRM
 C = RTRM + RTC((Comm3)
 D= RTRM + RLC(LonTalk)

Digit 12 - General

Command Voltage
 A = 220V
 B = 24V

Digit 13 - Filters de Ar

Available Static Pressure - (TRC)
 0 = **Not Applicable** (TRA)
 A = 0 mmCA (TRC)
 B = 2,5 mmCA (TRC)
 C = 5 mmCA (TRC)

Digit 14 - Air Filters

Filter - TRC
 0 = NOT / **Not Applicable** (TRA)
 1 = G1 3TELAS (TRC)
 2 = G4 LVD (TRC)

Digit 15 - Coil

Number of Circuits
 1 = 1 circuit
 2 = 2 circuits

Digit 16 - Coil

Refrigerant
 4 = R407C
 6=R410A

Digit 17 - Coil

0 = **Reserved**

Digit 18 - Coils c/ tratamento

supercial
 A = Sem tratamento (serpentina standard)
 Y = Yellow Fin (não aplicado TRCE)
 F = Tratamento Fenólico
 G = Tratamento Adsil

Digit 19 - Coil

0 = **Reserved**

Digit 20 - Circuito Condensation Control

0 = Standard
 A = Mechanical Type KVR + NRD - (TRC)
 B = Electromechanical - Type RGE - (TRA)
 *RGE - TRAE without RTRM and only 220V command

Digit 21 - Circuito

Controls
 0 = Standard
 A = With Service Valve (Disc. / Suc. / Liq.)

Digit 22 - Optional **

Packing / coil protection (grid)
 0 = No packing / No protection
 A = With packing / No protection
 B = No packing / With protection
 C = With packing / With protection

Digit 23 - Optional

Power Factor Correction
 0 = **Not Applicable**
 1 = Capacitor*
 * TRAE: capacitor in the compressor
 * TRCE: capacitor in the compressor + motor

Digit 24 - Optional

Weld
 0 = Standard

Digit 25 - Optional

Others
 0 = **Not Applicable**

Digit 26 - Pressure High/ Low

0 = High and Low Auto without regulation
 1 = Automatic and manual High Low without regulation
 2 = Automatic and manual High Low with regulation
 3 = High and Low manual with regulation
 * PRESSURE WITH REG. WITHOUT RTRM
 ** PRESSURE MANUAL HIGH LOW
 AUTOMATIC WITH ADJUSTMENT ONLY IN 50Hz

Digit 27 - Optional

Others
 0 = **Not Applicable**
 B = Three-Phase Voltage Supervisor (STT)

Digit 28 - Optional

Optional Fan Motor
 0 = **Not Applicable** / STD

Digit 29 - Optional

Fan Module
 0 = Without Optional or **Not Applicable**
 1 = Bearing NTN + Elastic Sleeve(TRC)
 2 = Fan painted (TRC)
 3 = 1 + 2 (TRC)

Digit 30 - Optional

0 = **Reserved**

Digit 31 - Destino da Unidade

L = Mercado Local
 E = Exportação

Digit 32 - Optional

0 = **Reserved**

Digit 33 - S/E

S = STD
 Z = ESPECIAL (Via SPE)

Notas:

- 1- QUADRO RTRM / RTRM+RTCI - COMANDO 24V. Para utilização de 2 condensadores com 1 evaporador, selecionar quadro com RTRM para primeira condensadora e quadro STANDARD para a segunda cond.
- 2- Dígito 22 - proteção serpentina com Grades somente para os modelos TRAE200 e TRAE250 nos novos gabinetes.

III-General Data

Coil and Fan Modules

Tab III-01 - General Data - Coil and Fan Modules - 050 to 500 - Forward-Curved (DX) and Backward-Curved (DL)

Models	Unit	050		075		100		125		150		200		250		300		350		400		500	
		DX	DL	DX	DL	DX	DL	DX	DL	DX	DL	DX	DL	DX	DL	DX	DL	DX	DL	DX	DL	DX	DL
Nominal Capacity	Ton	5		7,5		10		12,5		15		20		25		30		35		40		50	
Width	mm	960	1120	1120	1300	1430	1430	1500	1500	1500	1700	2000	2000	2400	2400	2770	2770	2770	2770	2770	2770	2770	2770
Depth	mm	580	740	740	850	740	850	740	740	740	740	740	800	930	930	930	930	930	930	930	1050	930	1050
Height	mm	730	730	870	870	870	870	1170	1170	1170	1170	1170	1170	1170	1170	1170	1170	1370	1370	1570	1570	1750	1750
Copper Tube Diameter	in.	3/8"		3/8"		3/8"		3/8"		3/8"		1/2"		1/2"		1/2"		1/2"		1/2"		1/2"	
Rows		4		4		4		4		4		4		4		4		4		4		4	
FPF (Fins per foot)		132		132		132		132		132		144		144		144		144		144		144	
Number of circuits		1		1		2		2		2		2		2		2		3		2		2	
Fin side area	m2	0,38		0,54		0,72		0,94		1, 12		1,54		1,91		2,34		2,81		3,28		3,75	
Fan Module																							
Width	mm	960	1120	1120	1300	1430	1430	1500	1500	1500	1700	2000	2000	2400	2400	2770	2770	2770	2770	2770	2770	2770	2770
Depth	mm	580	740	740	850	740	850	740	740	740	740	740	800	930	930	930	930	930	930	930	1050	930	1050
Height	mm	730	870	870	970	870	870	1170	1170	1170	1170	1170	1320	1170	1420	1170	1570	1370	1570	1370	1670	1370	1670
Number of Fans		1	1	1	1	1	1	2	2	2	2	2	2	2	2	3	2	3	2	3	2	3	2
Minimum Motor	HP	1	2	1,5	2	2	3	2	3	2	5	2	5	3	7,5	3	7,5	5	15	5	15	7,5	15
Maximum Motor	HP	2	5	3	5	5	7,5	5	10	7,5	10	10	15	10	25	10	25	15	25	15	40	20	40
Air Flow - Min	m3/h	2000		3000		4400		5500		6000		9000		12000		15000		17500		20000		25000	
Air Flow - Max	m3/h	4000		6000		8000		10000		12000		17000		21000		25000		31000		35000		40000	
Filters																							
Dimension	mm	424X525		504X665		439X665		462X477		462X477		472X477		572X477		531X477		531X577		531X677		531X767	
Quantity		02		02		03		06		06		08		08		10		10		10		10	

Notes:
 (1) Width, depth and height dimensions on table above are nominal reference measures; consider fan discharge and module assembly possibilities. Refer to model dimensions in this catalog.
 (2) Capacity are based on ARI 210 for equipments up to 5,0 TR and ARI 340 for equipments exceeding 5,0 TR.

General Data

TRAE / TRCE

Tab III-02 - General Data - Condensing Units TRAE - 050 to 250

Model	50	75	100	150	200	250
Nominal Cap.	Ton 5	7,5	10	15	20	25
Dimensions						
Width	mm 920	930	1140	1590	1067	1067
Depth	mm 420	620	800	800	1096	1096
Height	mm 818	920	1021	1275	1452	1452
Compressor						
Type	Scroll	Scroll	Scroll	Scroll	Scroll	Scroll
Qty./Ton	1	1	1 2	1 2	1 2	1 2
Condensing Coil						
Rows	2	2	2	2	2	2 2
FPF (Fins per foot)	228	216	216	216	204	204
Fin Side Area	m ² 0,8	1,01	1,67	1,67	2,24	2,97
Condensing Fan						
Quantity	1	1	1	1	2	1
Propeller diameter	mm 22"	26"	30"	30"	26"	35"
Motor	HP 0,25	0,75	1,	0	0,75	1,0
Number of Phases	1	1	1	1	1	1
Power	kW 0,35	0,55	0,75	0,75	0,75	0,55
RLA (2)	A 1,6	4	5,44	8	10,88	10,88
FLA(3)	A 1,6	4	5,44	5,44	8	10,88
Motor Rotation / No. Of Poles	RPM 800/8	790/8	800/8	800/8	790/8	830/8
Air Flow	m ³ /h 7234	9180	11900	11900	18360	23800
Pipe Diameters						
Number of Circuits	1	1	1	2	1	2
Liquid Line	In. 1/2"	1/2"	5/8"	1/2"	7/8"	1/2"
Suction Line	In. 7/8"	1 1/8"	1 3/8"	7/8"	1 5/8"	1 1/8"
Equipment Weight	kg 108	127	198	196	335	275

Tab. III-03 - General Data - Condensing Units TRCE 050 to 150

Model	050	075	100	150
Nominal Cap.	Ton 5	7,5	10	15
Dimensions				
Width	mm 993	1217	1491	1712
Depth	mm 560	560	560	560
Height	mm 1393	1494	1545	1849
Compressor				
N° Circuits	1	1	1	2
Type	Scroll	Scroll	Scroll	Scroll
Qty./Ton	Ton 1/5	1 /7,5	1/10	2/5
Condensing Coil				
Rows	4	4	4	4
FPF (Fin per Feet)	ft 144	144	144	144
Fin Side Area	m ² 0,55	0,83	0,99	1,72
Quantity	1	1	1	1
Condensing Fan				
Motor	CV 1,5	3	4	5
N° Fase	3	3	3	3
Air Flow	m ³ /h 5500	8250	9950	15750
Equipment Weigth	kg 184	210	305	310

Notes:

(1) RLA = Rated Load Amps(A); (2) FLA = Full Load Amps (A); (3) LRA = Locked Rated Amps (A).

General Data

TVR LX

Tab. III-04 - General Data Condensing Units TVR LX – 4TVH0086 to 4TVH0210

Model Numbers		<E>	4TVH0086DE0	4TVH0096DE0	4TVH0115DE0	4TVH0140DE0	4TVH0155DE0	4TVH0170DE0	4TVH0192DE0	4TVH0210DE0	
		<6>	4TVH0086D60	4TVH0096D60	4TVH0115D60	4TVH0140D60	4TVH0155D60	4TVH0170D60	4TVH0192D60	4TVH0210D60	
Cooling	Capacity	kW	25,2	28	33,5	40	45	50	56	61,5	
		BTU/H	86.000	95.500	114.300	136.500	153.500	170.500	191.100	210.000	
	Power Input	kW	5,36	6,22	7,79	9,30	10,98	12,87	14,51	16,44	
	Capacity Range (50% - 130%)	MBH	43-112	48-124	58-150	69-177	78-202	85-222	96-248	105-273	
	EER	WW	4,7	4,5	4,3	4,3	4,1	3,9	3,86	3,74	
Heating	Capacity	kW	27	31,5	37,5	45	50	56	63	69	
		BTU/H	92.100	107.500	128.000	153.500	170.600	191.100	214.900	235.400	
	Power Input	kW	4,87	5,94	7,65	9,38	10,87	13,18	15,29	17,12	
	Capacity Range (50% - 130%)	MBH	46-120	54-139	64-166	77-200	85-222	96-248	107-279	118-306	
	COP	WW	5,6	5,3	4,9	4,8	4,6	4,25	4,12	4,03	
Cooling Operation Range	C	-5 °C ~ 48 °C									
Heating Operation Range	C	-20 °C ~ 24 °C									
Air Flow	m³/h	12.000				14.000			16.000		
Sound Pressure	dB(A)	57			58		60		61		
Fin Type		Hydrophilic Aluminium									
Dimensions (W/H/D)	mm	990×1635×790				1340×1635×790					
Net Weight	kg	219			237		297		340		
Refrigerant		R410A									
Refrigerant Charge	kg	9			11		13		16		
Refrigerant Type		FVC68D / 500 ml									
Refrigerant Oil	ml	500				500x2					
Refrigerant Piping	Liquid Side	mm	Ø9,53			Ø12,7			Ø15,9		
	Gas Side	mm	Ø22,2			Ø25,4			Ø28,6		
	Oil Balance Pipe	mm	Ø6								
	Max. Equivalent Pipe Length	m	200								
	Max. Height difference between IUs	m	30								
	Max. Height difference for OU above IU	m	90								
Max. Height difference for OU below IU	m	110									
Max. Amount of IUs connected to OU		13	16	20	23	26	29	33	36		

<E> = 380-415 V, 3ø, 60 Hz

<6> = 220 V, 3ø, 60 Hz

Note: For installation information consult the catalog VRFDX-SLB001-PB of TVR LX + Solution Plus.

IV-Coil Module

Electrical Heaters

The Electrical heaters are tubular type, shielded and mounted on stainless steel box with closing of the connections with copper wire coated with suitable thermal insulation.

They are protected by a safety thermostat with automatic reactivation.

The following tables show the electrical heating options available for each model.

Control Panel

Trane optionally supplies control panels for heating. The control panels are supplied with:

- Electrical box, protection level IP54.
- Circuit breakers;
- Command contactors;
- Transformer;
- Terminal strip.

The electrical boxes are supplied in light gray coating, with slot-type latch, rubber-sealed door, wide power ranges, specifications as per Standard IEC 60947 and bottom flange. The control panel's table shows dimensions for heating panels.

Important:

When electrical heating is specified, panels are supplied separately, and are not inbuilt.

Tab IV-01 - Electrical Heating

		Electrical Heating								
		Power (kW)								
		1st Stage			2nd Stage					
		3	4,5	7,5	3	4,5	6	7,5	9	24
05	1x 3	1x 4,5			2x3	2x4,5				
07	1x 3	1x 4,5		1x 7,5	2x3	2x4,5				
10	1x 3	1x 4,5		1x 7,5	2x3	2x4,5	2x6			
12	1x 3	1x 4,5		1x 7,5	2x3	2x4,5	2x6	2x7,5		
15	1x 3	1x 4,5		1x 7,5	2x3	2x4,5	2x6	2x7,5	2x9	
20		1x 4,5		1x 7,5		2x4,5	2x6	2x7,5	2x9	
25		1x 4,5		1x 7,5		2x4,5	2x6	2x7,5	2x9	
30								2x7,5	2x9	
35								2x7,5	2x9	2x24
40								2x7,5	2x9	2x24
50								2x7,5	2x9	2x24
		3	4,5	6 7,5	6	9	12	15	18	48
		Total Power (kW) per Unit								

Tab IV-02 - Electrical panel dimensions: Heating

		Electrical Box			Mounting Plate	
		Height	Width	Depth	Height	Width
Heating	1 Stage	400	400	200	345	346
	2 Stages	500	500	200	445	446

Unit: mm

Coil Module

Tab IV-03 - Losses through coil - Solution Plus 05 to 50

Module DX* or DL* 05	Air Flow (m ³ /h)	2000	2200	2400	2600	2800	3000	3200	3400	3600	3800	4000
	Coil Loss (mmca)	8	10	11	13	15	17	19	21	23	25	27
Module DX* or DL* 07	Air Flow (m ³ /h)	3000	3300	3600	3900	4200	4500	4800	5100	5400	5700	6000
	Coil Loss (mmca)	9	11	12	14	16	18	20	22	25	27	29
Module DX* or DL* 10	Air Flow (m ³ /h)	4400	4800	5200	5600	6000	6400	6800	7200	7600	8000	
	Coil Loss (mmca)	11	12	14	16	18	20	22	25	27	29	
Module DX* or DL* 12	Air Flow (m ³ /h)	5500	6000	6500	7000	7500	8000	8500	9000	9500	10000	
	Coil Loss (mmca)	10	11	13	15	17	19	21	23	25	27	
Module DX* or DL* 15	Air Flow (m ³ /h)	6000	6600	7200	7800	8400	9000	9600	10200	10800	11400	12000
	Coil Loss (mmca)	8	10	12	13	15	17	19	21	23	25	28
Module DX* or DL* 20	Air Flow (m ³ /h)	9000	9800	10600	11400	12200	13000	13800	14600	15400	16200	17000
	Coil Loss (mmca)	11	12	14	16	18	20	22	24	27	29	32
Module DX* or DL* 25	Air Flow (m ³ /h)	12000	13000	14000	15000	16000	17000	18000	19000	20000	21000	
	Coil Loss (mmca)	12	14	16	18	20	22	24	27	29	31	
Module DX* or DL* 30	Air Flow (m ³ /h)	15000	16000	17000	18000	19000	20000	21000	22000	23000	24000	25000
	Coil Loss (mmca)	12	14	16	17	19	21	22	24	26	28	30
Module DX* or DL* 35	Air Flow (m ³ /h)	17500	19000	20500	22000	23500	25000	26500	28000	29500	31000	
	Coil Loss (mmca)	12	14	16	18	20	22	24	27	29	32	
Module DX* or DL* 40	Air Flow (m ³ /h)	20000	21500	23000	24500	26000	27500	29000	30500	32000	33500	35000
	Coil Loss (mmca)	11	13	15	16	18	20	22	24	26	28	30
Module DX* or DL* 50	Air Flow (m ³ /h)	25000	26500	28000	29500	31000	32500	34000	35500	37000	38500	40000
	Coil Loss (mmca)	13	15	16	18	19	21	23	24	26	28	30

Nota:

- Coil losses are losses of the set: coil module + fan module, equipped with class G1 filter.

V-Air Filters

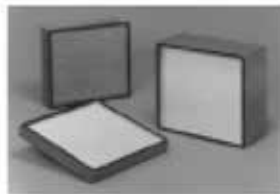
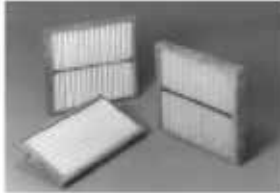

Available filtering for Solution Plus handler ranges from thick filters (G1 and G4) and fine filtering options (F5 and F8) up to absolute filters (A3) H.E.P.A.*

Filters can be placed both in the coil module and the mixing box. There is also the possibility of a final filtering module where fine filtering (class F) and absolute filtering (class A) can be configured.

In the coil module you may set a frame to place up to two filters of 1" each, resulting in a filtering option of two stages. When a mixing box module is used in the climate control assembly, the filter frame is installed inside the module so as to allow filter removal from the sides. The mixing box features the same filtering options as the coil module.

Disposable flat filters (class G) are made with a cardboard frame which is reinforced by perforated metallic fabric (treated with anti-corrosive resin) on both sides. The filter medium consists of a mesh of expanded glass wool with long threads and different diameters with a

progressive density. There is a filtering option which includes antibacterial treatment to further avoid the proliferation of microorganisms.

There is also the possibility of an additional module for final filtering. This option provides fine filtering (class F8 filter) and absolute filtering (classes A1 and A3) options to the climate control. Absolute filters are made of microfiber (pleated glass) with progressive density. On the other hand, class F filters are made of pleated synthetic mesh (F5) and micropleated paper (F8); they provide a large filtering surface along with a high resistance to humidity.

Dimensions and number

Dimensions and number of available filters can be found in general data tables. The standard filtering consists of a disposable glass wool filter, 1" thick and a grade of filtering ABNT G4, according to NBR6401.

As an option, other filter types and double filtering can be supplied, as listed below:

Tab. V-01 – Remote air filter coil/mixing box module

Filtering class	Features	Average gravimetric efficiency
F5	Pleated synthetic mesh 2"	96%
F8	Flat 3" Microfiber	>90%
F8	Bag 300mm	>90%
G1	Aluminium corrugated fabric 1"	60-70%
G4	Glass wool 1"	>90%

Tab. V-02 – Air filter final filtering module

Filtering class	Features	Average gravimetric efficiency
F8	Bag 300mm	>90%
A3	Absolute H.E.P.A.*	>99.97%

(*)H.E.P.A. – High Efficiency Particulate Air Filter

Air Filters

Tab. V-03 – Comparison of standards.

Thick filter			
Rated efficiency (coarse particles)	EN779 / NBR16401-3:2008	NBR6401	Ashrae 52.2
39%	G - 1	G - 0	MERV 1
50%			
59%			
60%			
64%			
65%	G - 2	G - 1	MERV 2
69%			
70%			
74%			
75%			
79%	G - 2	G - 2	MERV 4
80%			
84%			
85%	G - 3	G - 3	MERV 5
89%			
> 90%			

Thick filter			
Rated efficiency (coarse particles)	EN779	NBR6401	Ashrae 52.2
20%	F - 5	F - 1	MERV 7
24%			
25%			
29%			
30%			
39%			
40%			
45%			
50%			
55%			
59%	F - 6	F - 2	MERV 9
60%			
65%			
69%			
70%			
75%	F - 7	F - 2	MERV 10
79%			
80%			
89%	F - 8	F - 3	MERV 11
90%			
94%			
95%	F - 9	F - 3	MERV 12
> 95%			

Filters

The coil module includes a frame to place up to two filters of 1" each, to suit the option of 02-stage filtering. When using the mixing box module, the filter frame is placed inside the mixing box so as to allow the filters removal from the sides. The mixing box has the same filtering options as the coil module.

Standard filter

The standard filtering consists of a disposable glass wool filter, 1" thick and a grade of filtering ABNT G4. As an option, other types of filters and double filtering can be provided, as shown in the list below:

Tab. V-04 – Pressure drop in filters (clean)

Filter	Drop (mmca) Initial (phase velocity 2.0 m/s)	Final (Recommended)
G4	3	16
F5	8	30
F8	12	50
A3	38	60



VI-Cooling Capacities

TRAE (60Hz)

Tab. VI - 01 - Cooling Capacity - Solution Plus 050: DX050 with TRAE 050 - 1 Circuit

Air Flow (m³/h)	TEAE BS	Inlet Air Temperature on Condenser - BU (°C)																																			
		29,5						35						40,5						46																	
		Evaporator Entering Wet Bulb Temperature - BU (°C)																																			
		16			19,5			23			16			19,5			23			16			19,5			23											
°C	Total cap.	Sens. Cap.	KW	Total cap.	Sens. Cap.	KW	Total cap.	Sens. Cap.	KW	Total cap.	Sens. Cap.	KW	Total cap.	Sens. Cap.	KW	Total cap.	Sens. Cap.	KW	Total cap.	Sens. Cap.	KW	Total cap.	Sens. Cap.	KW	Total cap.	Sens. Cap.	KW	Total cap.	Sens. Cap.	KW							
2000	24	12,91	10,09	5,35	14,31	7,94	5,46	15,79	5,70	5,58	12,33	9,81	5,84	13,67	7,66	5,97	15,07	5,42	6,09	11,67	9,49	6,37	12,95	7,36	6,50	14,27	5,13	6,62	10,93	9,14	6,92	12,14	7,02	7,05	13,38	4,80	7,17
	27	12,92	11,84	5,35	14,31	9,70	5,46	15,79	7,48	5,58	12,34	11,56	5,85	13,66	9,42	5,97	15,06	7,20	6,09	11,68	11,24	6,37	12,94	9,12	6,50	14,27	6,90	6,62	10,94	10,89	6,92	12,14	8,78	7,05	13,38	6,58	7,17
	29,5	12,93	12,93	5,34	14,31	11,16	5,46	15,79	8,95	5,58	12,35	12,35	5,85	13,66	10,88	5,97	15,06	8,68	6,09	11,69	11,69	6,37	12,94	10,58	6,50	14,26	8,38	6,62	10,95	10,95	6,92	12,14	10,24	7,05	13,37	8,06	7,17
2600	24	14,31	13,60	5,81	15,72	9,96	5,93	17,22	6,22	6,04	13,61	13,29	6,31	14,94	9,66	6,44	16,33	5,92	6,55	12,83	12,83	6,84	14,08	9,33	6,97	15,38	5,61	7,08	11,96	11,96	7,38	13,14	8,98	7,51	14,35	5,27	7,62
	27	14,33	14,33	5,81	15,72	12,95	5,93	17,21	9,25	6,04	13,63	13,63	6,31	14,94	12,65	6,44	16,33	8,95	6,56	12,85	12,85	6,84	14,09	12,33	6,97	15,37	8,63	7,08	12,01	12,01	7,37	13,15	11,98	7,51	14,34	8,30	7,62
	29,5	14,43	14,43	5,80	15,74	15,44	5,93	17,21	11,76	6,04	13,83	13,83	6,31	14,95	14,95	6,44	16,33	11,46	6,56	13,18	13,18	6,85	14,10	14,10	6,97	15,37	11,14	7,08	12,45	12,45	7,41	13,17	13,17	7,51	14,34	10,81	7,62
3400	24	14,99	14,99	5,84	15,75	15,75	5,93	17,21	14,26	6,05	14,39	14,39	6,36	14,97	14,97	6,44	16,33	13,96	6,56	13,73	13,73	6,90	14,12	14,12	6,97	15,38	13,65	7,08	12,98	12,98	7,46	13,19	13,19	7,50	14,35	13,31	7,62
	27	14,66	14,66	6,10	16,06	10,79	6,22	17,56	6,42	6,34	13,92	13,92	6,60	15,24	10,48	6,73	16,63	6,12	6,86	13,11	13,11	7,13	14,35	10,15	7,26	15,64	5,80	7,38	12,21	12,21	7,67	13,38	9,80	7,80	14,57	5,46	7,92
	29,5	14,68	14,68	6,10	16,07	14,31	6,22	17,55	9,98	6,35	13,96	13,96	6,59	15,25	14,01	6,73	16,62	9,68	6,86	13,18	13,18	7,11	14,37	13,68	7,26	15,63	9,36	7,38	12,38	12,38	7,65	13,39	13,32	7,80	14,57	9,01	7,92
4000	24	15,03	15,03	6,10	16,09	16,09	6,23	17,55	12,93	6,35	14,40	14,40	6,61	15,27	15,27	6,74	16,63	12,63	6,86	13,70	13,70	7,15	14,38	14,38	7,26	15,64	12,31	7,38	12,93	12,93	7,71	13,41	13,41	7,80	14,57	11,97	7,92
	27	15,63	15,63	6,15	16,10	16,10	6,23	17,56	15,88	6,35	14,99	14,99	6,67	15,29	15,29	6,73	16,63	15,58	6,86	14,27	14,27	7,21	14,42	14,42	7,25	15,65	15,26	7,38	13,47	13,47	7,76	13,48	13,48	7,77	14,58	14,58	7,92

Tab. VI - 02 - Cooling Capacity - Solution Plus 075: DX075 with TRAE 075 - 1 Circuit

Air Flow (m³/h)	TEAE BS	Inlet Air Temperature on Condenser - BU (°C)																																			
		29,5						35						40,5						46																	
		Evaporator Entering Wet Bulb Temperature - BU (°C)																																			
		16			19,5			23			16			19,5			23			16			19,5			23											
°C	Total cap.	Sens. Cap.	KW	Total cap.	Sens. Cap.	KW	Total cap.	Sens. Cap.	KW	Total cap.	Sens. Cap.	KW	Total cap.	Sens. Cap.	KW	Total cap.	Sens. Cap.	KW	Total cap.	Sens. Cap.	KW	Total cap.	Sens. Cap.	KW	Total cap.	Sens. Cap.	KW	Total cap.	Sens. Cap.	KW							
3000	24	19,05	14,98	8,20	21,10	11,75	8,45	23,27	8,38	8,71	18,20	14,57	9,04	20,13	11,33	9,31	22,17	7,97	9,59	17,29	14,13	9,95	19,10	10,89	10,23	20,99	7,53	10,52	16,30	13,67	10,92	17,96	10,42	11,19	19,71	7,07	11,47
	27	19,06	17,60	8,20	21,09	14,39	8,45	23,26	11,05	8,71	18,21	17,19	9,04	20,13	13,97	9,31	22,16	10,64	9,59	17,30	16,75	9,95	19,09	13,53	10,23	20,98	10,20	10,52	16,31	16,29	10,92	17,96	13,06	11,19	19,70	9,73	11,47
	29,5	19,07	19,07	8,20	21,09	16,58	8,45	23,26	13,27	8,71	18,22	18,22	9,04	20,13	16,16	9,31	22,16	12,85	9,59	17,32	17,32	9,95	19,09	15,72	10,23	20,98	12,41	10,52	16,32	16,32	10,92	17,96	15,26	11,19	19,70	11,95	11,47
3900	24	20,13	17,27	8,50	22,20	13,08	8,76	24,37	8,74	9,01	19,17	16,84	9,35	21,11	12,64	9,63	23,14	8,30	9,90	18,15	16,37	10,26	19,96	12,18	10,54	21,83	7,85	10,83	17,05	15,88	11,21	18,71	11,69	11,49	20,43	7,37	11,77
	27	20,14	20,14	8,51	22,19	16,51	8,76	24,36	12,20	9,02	19,19	19,19	9,35	21,11	16,07	9,63	23,14	11,77	9,90	18,17	18,17	10,26	19,96	15,61	10,54	21,83	11,32	10,83	17,08	17,08	11,22	18,71	15,12	11,49	20,43	10,84	11,77
	29,5	20,16	20,16	8,50	22,20	19,36	8,76	24,35	15,08	9,02	19,21	19,21	9,34	21,12	18,92	9,63	23,13	14,65	9,90	18,22	18,22	10,25	19,97	18,46	10,55	21,82	14,20	10,83	17,20	17,20	11,21	18,72	17,97	11,49	20,42	13,72	11,77
5100	24	21,07	20,23	8,98	23,14	14,77	9,25	25,28	9,15	9,50	20,02	19,77	9,83	21,95	14,31	10,12	23,95	8,70	10,39	18,90	18,90	10,74	20,69	13,84	11,03	22,54	8,23	11,32	17,70	17,70	11,69	19,34	13,33	11,97	21,04	7,75	12,26
	27	21,10	21,10	8,99	23,14	19,26	9,25	25,27	13,68	9,50	20,05	20,05	9,83	21,95	18,80	10,12	23,94	13,24	10,39	18,94	18,94	10,73	20,70	18,33	11,03	22,53	12,77	11,32	17,77	17,77	11,67	19,35	17,82	11,97	21,03	12,28	12,26
	29,5	21,27	21,27	8,96	23,15	22,99	9,25	25,27	17,45	9,50	20,38	20,38	9,84	21,97	21,97	10,12	23,93	17,00	10,39	19,44	19,44	10,78	20,72	20,72	11,04	22,52	16,54	11,32	18,40	18,40	11,76	19,37	19,37	11,98	21,03	16,05	12,26
6000	24	22,11	22,11	9,07	23,17	23,17	9,25	25,27	21,20	9,50	21,20	21,20	9,96	21,99	21,99	10,12	23,94	20,76	10,39	20,22	20,22	10,90	20,74	20,74	11,03	22,53	20,29	11,32	19,14	19,14	11,88	19,41	19,41	11,96	21,04	19,80	12,26
	27	21,57	21,57	9,44	23,63	16,01	9,71	25,75	9,43	9,97	20,47	20,47	10,29	22,39	15,55	10,58	24,36	8,98	10,87	19,30	19,30	11,20	21,07	15,06	11,50	22,89	8,51	11,79	18,04	18,04	12,14	19,67	14,55	12,43	21,35	8,02	12,73
	29,5	21,60	21,60	9,43	23,64	21,29	9,71	25,74	14,77	9,97	20,53	20,53	10,27	22,40	20,83	10,59	24,35	14,32	10,87	19,41	19,41	11,16	21,09	20,34	11,50	22,89	13,85	11,79	18,29	18,29	12,12	18,32	18,32	12,14	21,34	13,36	12,73
32	23,04	23,04	9,57	23,67	23,67	9,72	25,74	23,62	9,97	22,05	22,05	10,46	22,45	22,45	10,58	24,36	23,17	10,87	20,99	20,99	11,41	21,17	21,17	11,48	22,89	22,70	11,80	19,83	19,83	12,38	19,84	19,84	12,40	21,36	21,36	12,73	

Notes:

- (1)TEAE - Inlet air temperature on evaporator;
 - (2)BS - Dry Bulb;
 - (3)BU - Humid Bulb;
 - (4)Consumption values refers only to condensers units;
 - (5)Capacity do not include heat effect of motor on evaporator;
 - (6)Capacities are based on 15m max. linear and 10m max. gap between evaporator and condenser unit;
 - (7)Total and sensitive capacity: Mkal/h;
 - (8)Heat generated by fan motor and fan performance table. MBH = Mkal/h x 3,9682.10⁶;
- Cap. Total => 0.96
 Cap. Sens. => 0.98
 KW => 1.01

Cooling Capacities

TRAE (60Hz)

Tab. VI - 03 - Cooling Capacity - Solution Plus 100: DX100 with TRAE 100 - 1 Circuit

Air Flow (m3/h)	TEAE BS	Inlet Air Temperature on Condenser - BU (°C)																																																														
		29,5									35									40,5									46																																			
		16							19,5							23							16							19,5							23							16							19,5							23						
		°C	Total cap.	Sens. Cap.	KW	Total cap.	Sens. Cap.	KW	Total cap.	Sens. Cap.	KW	Total cap.	Sens. Cap.	KW	Total cap.	Sens. Cap.	KW	Total cap.	Sens. Cap.	KW	Total cap.	Sens. Cap.	KW	Total cap.	Sens. Cap.	KW	Total cap.	Sens. Cap.	KW	Total cap.	Sens. Cap.	KW	Total cap.	Sens. Cap.	KW	Total cap.	Sens. Cap.	KW																										
4400	24	25,12	20,61	9,06	27,91	15,94	9,30	30,92	11,10	9,54	23,99	20,08	9,95	26,63	15,41	10,21	29,46	10,57	10,49	22,77	19,52	10,93	25,25	14,84	11,20	27,90	10,00	11,49	21,45	18,91	12,00	23,76	14,24	12,27	26,20	9,40	12,55																											
	27	25,13	24,45	9,06	27,90	19,81	9,30	30,91	15,01	9,54	24,01	23,92	9,95	26,63	19,28	10,21	29,46	14,48	10,49	22,80	22,80	10,93	25,25	18,71	11,20	27,89	13,92	11,49	21,48	21,48	12,01	23,75	18,11	12,27	26,19	13,31	12,55																											
	29,5	25,16	25,16	9,07	27,91	23,02	9,30	30,91	18,26	9,54	24,02	24,02	9,95	26,63	22,49	10,22	29,45	17,73	10,49	22,81	22,81	10,93	25,26	21,93	11,21	27,88	17,16	11,49	21,52	21,52	11,99	23,77	21,32	12,27	26,18	16,56	12,55																											
5600	24	26,35	23,64	9,43	29,19	17,70	9,67	32,23	11,57	9,91	25,11	23,08	10,32	27,77	17,14	10,59	30,63	11,02	10,87	23,77	22,49	11,30	26,27	16,55	11,58	28,93	10,44	11,88	22,34	21,86	12,36	24,64	15,92	12,64	27,08	9,82	12,93																											
	27	26,39	26,39	9,43	29,19	22,63	9,67	32,22	16,55	9,91	25,14	25,14	10,33	27,77	22,07	10,59	30,62	16,00	10,87	23,81	23,81	11,31	26,27	21,48	11,59	28,92	15,42	11,88	22,37	22,37	12,36	24,65	20,85	12,64	27,07	14,80	12,93																											
	29,5	26,44	26,44	9,42	29,20	26,72	9,68	32,21	20,69	9,91	25,25	25,25	10,30	27,79	26,16	10,60	30,61	20,14	10,87	24,06	24,06	11,29	26,29	25,58	11,59	28,91	19,56	11,88	22,88	22,88	12,38	24,67	24,67	12,65	27,06	18,93	12,93																											
6800	24	27,24	26,60	9,88	30,09	19,40	10,13	33,13	12,00	10,38	25,90	25,90	10,78	28,58	18,82	11,06	31,43	11,44	11,34	24,48	24,48	11,76	26,97	18,22	12,05	29,63	10,84	12,35	22,96	22,96	12,81	25,25	17,58	13,10	27,68	10,21	13,41																											
	27	27,28	27,28	9,88	30,10	25,39	10,13	33,12	18,05	10,38	25,95	25,95	10,77	28,59	24,81	11,06	31,42	17,49	11,34	24,55	24,55	11,74	26,99	24,21	12,05	29,62	16,89	12,35	23,09	23,09	12,78	25,27	23,57	13,11	27,67	16,26	13,41																											
	29,5	27,66	27,66	9,86	30,12	30,12	10,14	33,11	23,07	10,38	26,55	26,55	10,78	28,62	28,62	11,07	31,42	22,51	11,34	25,35	25,35	11,79	27,02	27,02	12,06	29,62	21,91	12,36	24,05	24,05	12,88	25,31	25,31	13,11	27,68	21,28	13,41																											
8000	24	27,90	27,90	10,45	30,76	21,07	10,72	33,80	12,41	10,97	26,51	26,51	11,35	29,18	20,48	11,65	32,03	11,83	11,94	25,02	25,02	12,33	27,50	19,86	12,64	30,15	11,23	12,96	23,42	23,42	13,39	25,71	19,21	13,69	28,12	10,58	14,01																											
	27	27,62	27,62	10,34	30,78	28,11	10,72	33,79	19,52	10,97	26,47	26,47	11,26	29,20	27,52	11,65	32,02	18,95	11,94	25,23	25,23	12,27	27,52	26,91	12,64	30,14	18,34	12,96	23,88	23,88	13,35	25,74	25,74	13,69	28,11	17,70	14,01																											
	29,5	28,85	28,85	10,45	30,81	30,81	10,72	33,78	25,43	10,97	27,65	27,65	11,39	29,23	29,23	11,66	32,02	24,86	11,94	26,37	26,37	12,40	27,56	27,56	12,65	30,14	24,25	12,96	24,96	24,96	13,49	25,77	25,77	13,70	28,12	23,61	14,01																											
32	30,10	30,10	10,56	30,84	30,84	10,71	33,80	31,32	10,97	28,86	28,86	11,51	29,29	29,29	11,63	32,03	30,75	11,95	27,51	27,51	12,53	27,69	27,69	12,60	30,16	30,15	12,96	26,04	26,04	13,62	26,05	26,05	13,65	28,15	28,15	14,02																												

Tab. VI - 04 - Tab. VI -04 - Cooling Capacity - Solution Plus 100: DX100 with TRAE 100 - 2 Circuits

Air Flow (m3/h)	TEAE BS	Inlet Air Temperature on Condenser - BU (°C)																																			
		29,5									35									40,5									46								
		16			19,5			23			16			19,5			23			16			19,5			23			16			19,5			23		
		°C	Total cap.	Sens. Cap.	KW	Total cap.	Sens. Cap.	KW	Total cap.	Sens. Cap.	KW	Total cap.	Sens. Cap.	KW	Total cap.	Sens. Cap.	KW	Total cap.	Sens. Cap.	KW	Total cap.	Sens. Cap.	KW	Total cap.	Sens. Cap.	KW	Total cap.	Sens. Cap.	KW	Total cap.	Sens. Cap.	KW	Total cap.	Sens. Cap.	KW		
4400	24	26,50	21,27	10,75	29,37	16,55	10,98	32,44	11,66	11,22	25,30	20,70	11,73	28,03	15,99	11,98	30,92	11,10	12,23	23,94	20,06	12,77	26,55	15,37	13,03	29,27	10,49	13,28	22,40	19,35	13,86	24,87	14,68	14,12	27,42	9,83	14,36
	27	26,51	25,11	10,75	29,36	20,42	10,98	32,43	15,57	11,22	25,32	24,54	11,73	28,03	19,86	11,98	30,92	15,01	12,23	23,96	23,90	12,77	26,54	19,24	13,03	29,26	14,41	13,28	22,43	22,43	13,86	24,87	18,56	14,12	27,41	13,75	14,36
	29,5	26,54	26,54	10,75	29,36	23,64	10,98	32,43	18,82	11,22	25,34	25,34	11,73	28,03	23,07	11,98	30,91	18,26	12,23	23,98	23,98	12,77	26,54	22,46	13,03	29,25	17,66	13,28	22,45	22,45	13,85	24,88	21,77	14,12	27,41	16,99	14,36
5600	24	27,84	24,31	11,12	30,75	18,32	11,36	33,83	12,13	11,59	26,52	23,72	12,10	29,26	17,73	12,36	32,16	11,55	12,60	25,05	23,06	13,14	27,65	17,09	13,40	30,36	10,93	13,65	23,39	22,33	14,22	25,85	16,39	14,48	28,36	10,25	14,72
	27	27,87	27,87	11,12	30,74	23,25	11,36	33,82	17,12	11,59	26,55	26,55	12,11	29,26	22,66	12,36	32,15	16,53	12,60	25,08	25,08	13,15	27,65	22,02	13,41	30,35	15,91	13,65	23,43	23,43	14,23	25,85	21,32	14,48	28,35	15,23	14,72
	29,5	27,90	27,90	11,11	30,75	27,34	11,36	33,82	21,25	11,59	26,60	26,60	12,09	29,27	26,75	12,36	32,15	20,67	12,60	25,20	25,20	13,13	27,66	26,11	13,41	30,34	20,04	13,65	23,77	23,77	14,22	25,87	25,41	14,48	28,35	19,36	14,72
6800	24	28,46	28,46	11,13	30,77	30,77	11,36	33,81	25,37	11,60	27,38	27,38	12,14	29,30	29,30	12,36	32,15	24,79	12,60	26,16	26,16	13,21	27,69	27,69	13,41	30,34	24,16	13,65	24,79	24,79	14,33	25,90	25,90	14,49	28,35	23,49	14,72
	27	28,79	27,28	11,57	31,71	20,02	11,82	34,78	12,56	12,06	27,38	26,66	12,56	30,13	19,42	12,82	33,00	11,96	13,07	25,83	25,83	13,60	28,41	18,76	13,86	31,09	11,32	14,11	24,09	24,09	14,67	26,51	18,05	14,93	29,00	10,64	15,17
	29,5	28,83	28,83	11,57	31,71	26,01	11,82	34,77	18,61	12,06	27,43	27,43	12,56	30,14	25,40	12,82	32,99	18,01	13,07	25,87	25,87	13,59	28,42	24,74	13,86	31,08	17,37	14,11	24,17	24,17	14,65	26,53	26,03	14,94	28,99	16,69	15,17
8000	24	29,50	29,50	12,14	32,43	21,69	12,40	35,48	12,96	12,65	28,03	28,03	13,13	30,77	21,07	13,40	33,62	12,35	13,66	26,41	26,41	14,17	28,97	20,40	14,44	31,63	11,70	14,71	24,60	24,60	15,24	27,01	19,68	15,51	29,47	11,01	15,76
	27	29,55	29,55	12,14	32,44	28,73	12,40	35,47	20,07	12,66	27,99	27,99	13,08	30,78	28,11	13,41	33,60	19,46	13,66	26,54	26,54	14,13	28,99	27,45	14,45	31,62	18,82	14,71	24,90	24,90	15,18	27,03	26,73	15,51	29,46	18,13	15,76
	29,5	30,19	30,19	12,11	32,46	32,46	12,41	35,46	25,98	12,66	28,94	28,94	13,13	30,81	30,81	13,41	33,60	25,37	13,67	27,56	27,56	14,20	29,03	29,03	14,45	31,62	24,73	14,71	26,01	26,01	15,30	27,07	27,07	15,52	29,46	24,04	15,77
32	31,44	31,44	12,22	32,49	32,49	12,41	35,47	31,87	12,66	30,15	30,15	13,24	30,85	30,85	13,40	33,61	31,26	13,67	28,72	28,72	14,31	29,09	29,09	14,42	31,64	30,62	14,71	27,12	27,12	15,41	27,21	27,21	15,46	29,48	29,48	15,77	

- Notes:
 (1) TEAE - Inlet air temperature on evaporator;
 (2) BS - Dry Bulb;
 (3) BU - Humid Bulb;
 (4) Consumption values refers only to condensers units;
 (5) Capacity do not include heat effect of motor on evaporator;
 (6) Capacities are based on 15m max. linear and 10m max. gap between evaporator and condenser unit;
 (7) Total and sensitive capacity: Mkal/h;
 (8) Heat generated by fan motor and fan



Cooling Capacities

TRAE (60Hz)

Tab. VI - 05 - Cooling Capacity - Solution 125: DX125 with TRAE050 1C + TRAE075 1C

Air Flow (m3/h)	TEAE BS	Inlet Air Temperature on Condenser - BU (°C)																																							
		29,5										35										40,5										46									
		Evaporator Entering Wet Bulb Temperature - BU (°C)																																							
		16			19,5			23			16			19,5			23			16			19,5			23			16			19,5			23						
°C	Total cap.	Sens. Cap.	KW	Total cap.	Sens. Cap.	KW	Total cap.	Sens. Cap.	KW	Total cap.	Sens. Cap.	KW	Total cap.	Sens. Cap.	KW	Total cap.	Sens. Cap.	KW	Total cap.	Sens. Cap.	KW	Total cap.	Sens. Cap.	KW	Total cap.	Sens. Cap.	KW	Total cap.	Sens. Cap.	KW	Total cap.	Sens. Cap.	KW								
5500	24	32,75	26,41	13,83	36,22	20,49	14,20	39,88	14,33	14,57	31,24	25,70	15,17	34,53	19,78	15,57	37,97	13,63	15,96	29,61	24,93	16,61	26	32,69	19,02	17,02	35,91	12,88	17,42	27,81	24,10	18,12	38	30,68	18,19	18,52	39	33,66	12,08	18,91	
	27	32,77	31,22	13,83	36,21	25,32	14,20	39,87	19,22	14,57	31,27	30,50	15,17	34,52	24,61	15,57	37,96	18,52	15,96	29,64	29,57	16,61	29	32,69	23,85	17,02	35,90	17,77	17,42	27,84	27,84	18,13	41	30,68	23,03	18,52	42	33,65	16,97	18,91	
	29,5	32,80	32,80	13,83	36,21	29,34	14,20	39,86	23,28	14,57	31,30	31,30	15,17	34,53	28,63	15,57	37,95	22,58	15,96	29,65	29,65	16,60	32	32,70	27,87	17,02	35,89	21,83	17,42	27,87	27,87	18,10	44	30,69	27,05	18,52	45	33,64	21,03	18,92	
7000	24	34,35	30,19	14,33	37,84	22,66	14,71	41,50	14,90	15,07	32,69	29,44	15,68	35,98	21,92	16,08	39,41	14,17	16,47	30,90	28,64	17,11	74	33,98	21,14	17,53	37,16	13,40	17,93	28,95	27,78	18,61	86	31,79	20,29	19,01	87	34,74	12,58	19,40	
	27	34,39	34,39	14,34	37,83	28,82	14,71	41,49	21,12	15,07	32,74	32,74	15,68	35,97	28,08	16,08	39,40	20,39	16,47	30,95	30,95	17,12	77	33,98	27,30	17,53	37,15	19,62	17,93	28,85	28,85	18,56	89	31,81	26,45	19,02	90	34,73	18,80	19,41	
	29,5	34,43	34,43	14,32	37,85	33,94	14,71	41,48	26,29	15,07	32,83	32,83	15,65	35,99	33,20	16,08	39,39	25,56	16,47	31,18	31,18	17,08	80	34,01	32,42	17,53	37,14	24,79	17,93	29,48	29,48	18,62	92	31,83	31,52	19,02	93	34,73	23,97	19,41	
8500	24	35,48	33,87	14,92	38,96	24,77	15,30	42,62	15,41	15,67	33,72	33,11	16,27	36,98	24,01	16,68	40,39	14,66	17,07	31,81	31,81	17,70	122	34,86	23,21	18,12	38,02	13,88	18,53	29,75	29,75	19,20	134	32,56	22,34	19,60	135	35,48	13,05	20,00	
	27	35,53	35,53	14,93	38,97	32,25	15,31	42,60	22,97	15,67	33,77	33,77	16,27	36,99	31,49	16,68	40,38	22,23	17,07	31,88	31,88	17,68	125	34,88	30,69	18,13	38,00	21,44	18,53	29,89	29,89	19,14	137	32,59	22,83	19,61	138	35,47	20,61	20,00	
	29,5	35,85	35,85	14,87	38,99	38,47	15,31	42,60	29,25	15,67	34,32	34,32	16,25	37,02	37,02	16,69	40,37	28,50	17,08	32,72	32,72	17,73	128	34,91	34,91	18,13	38,00	27,72	18,53	30,95	30,95	19,26	140	32,62	32,62	19,61	141	35,48	26,89	20,00	
10000	24	37,23	37,23	15,01	39,03	39,03	15,31	42,61	35,50	15,67	35,71	35,71	16,42	37,06	37,06	16,69	40,38	34,76	17,08	34,06	34,06	17,90	131	34,95	34,95	18,12	38,02	33,97	18,53	32,23	32,23	19,44	143	32,69	32,69	19,58	144	35,50	33,15	20,00	
	27	36,33	36,33	15,64	39,79	26,84	16,04	43,43	15,90	16,42	34,48	34,48	17,00	37,72	26,07	17,42	41,11	15,14	17,82	32,49	32,49	18,43	170	35,51	25,25	18,86	38,64	14,35	19,28	30,34	30,34	19,92	182	33,13	24,38	20,34	183	36,02	13,51	20,74	
	29,5	36,39	36,39	15,62	39,81	35,64	16,04	43,42	24,80	16,42	34,57	34,57	16,93	37,75	34,87	17,42	41,09	24,04	17,83	32,72	32,72	18,35	173	35,54	34,05	18,86	38,63	23,24	19,28	30,78	30,78	19,84	185	33,16	33,00	20,34	186	36,01	22,41	20,75	
32	38,81	38,81	15,78	39,88	39,88	16,04	43,43	39,54	16,42	37,16	37,16	17,19	37,83	37,83	17,40	41,11	38,78	17,83	35,38	35,38	18,68	179	35,69	35,69	18,79	38,66	37,99	19,28	33,41	33,41	20,21	191	33,43	33,43	20,24	192	36,05	36,05	20,75		

Tab. VI - 06 - Cooling Capacity - Solution Plus 150: DX150 with TRAE 150 - 1 Circuit

Air Flow (m3/h)	TEAE BS	Inlet Air Temperature on Condenser - BU (°C)																																							
		29,5										35										40,5										46									
		Evaporator Entering Wet Bulb Temperature - BU (°C)																																							
		16			19,5			23			16			19,5			23			16			19,5			23			16			19,5			23						
°C	Total cap.	Sens. Cap.	KW	Total cap.	Sens. Cap.	KW	Total cap.	Sens. Cap.	KW	Total cap.	Sens. Cap.	KW	Total cap.	Sens. Cap.	KW	Total cap.	Sens. Cap.	KW	Total cap.	Sens. Cap.	KW	Total cap.	Sens. Cap.	KW	Total cap.	Sens. Cap.	KW	Total cap.	Sens. Cap.	KW	Total cap.	Sens. Cap.	KW								
6000	24	40,32	31,07	15,58	44,35	24,46	16,03	48,62	17,59	16,50	38,41	30,12	17,12	42,22	23,53	17,62	46,23	16,67	18,13	36,40	29,14	18,74	39,97	22,56	19,28	43,69	15,71	19,81	34,21	28,10	20,40	37,48	21,51	20,95	40,93	14,70	21,50				
	27	40,44	36,19	15,58	44,37	29,74	16,04	48,61	22,92	16,49	38,57	35,23	17,13	42,24	28,81	17,63	46,21	22,00	18,12	36,59	34,23	18,76	39,99	27,84	19,28	43,67	21,05	19,81	34,44	33,15	20,42	37,50	26,79	20,96	40,92	20,03	21,50				
	29,5	40,79	40,57	15,61	44,39	34,13	16,04	48,61	27,35	16,49	38,99	38,99	17,17	42,27	33,20	17,63	46,21	26,43	18,13	37,14	37,14	18,82	40,03	32,24	19,29	43,68	25,48	19,81	35,25	35,25	20,54	37,57	31,19	20,96	40,93	24,46	21,50				
7800	24	41,96	41,96	15,73	44,50	38,54	16,04	48,62	31,76	16,50	40,36	40,36	17,34	42,41	37,62	17,64	46,23	30,85	18,13	38,63	38,63	19,04	40,20	36,44	19,30	43,69	29,89	19,81	36,69	36,69	20,78	37,77	35,37	20,98	40,95	28,88	21,50				
	27	42,23	35,47	16,19	46,22	26,92	16,65	50,44	18,10	17,11	40,17	34,51	17,74	43,89	25,96	18,25	47,85	17,17	18,75	37,98	33,26	19,37	41,44	24,98	19,91	45,09	16,21	20,43	35,61	32,14	21,02	38,75	23,91	21,57	42,15	15,19	22,11				
	29,5	42,64	42,06	16,21	46,25	33,79	16,65	50,43	25,04	17,11	40,64	40,64	17,78	43,93	32,83	18,25	47,83	24,11	18,75	38,56	38,56	19,42	41,48	31,85	19,91	45,08	23,14	20,43	36,35	36,35	21,11	38,81	30,79	21,57	42,15	22,13	22,11				
10200	24	45,61	45,61	16,51	46,71	44,94	16,67	50,46	36,54	17,11	43,73	43,73	18,15	44,46	43,96	18,28	47,88	35,61	18,75	41,72	41,71	19,87	42,11	42,11	19,96	45,14	34,65	20,43	39,48	39,48	21,61	39,61	39,61	21,65	42,24	33,64	22,11				
	27	43,93	40,81	17,17	47,74	30,12	17,67	51,89	18,75	18,15	41,73	39,79	18,74	45,24	29,15	19,28	49,13	17,83	19,79	39,43	38,72	20,38	42,62	28,15	20,94	46,21	16,85	21,47	36,93	36,93	22,03	39,77	27,08	22,60	43,12	15,84	23,15				
	29,5	45,05	45,05	17,22	47,82	39,11	17,66	51,88	27,83	18,15	43,08	43,08	18,85	45,34	38,15	19,27	49,12	26,90	19,79	40,96	40,96	20,55	42,74	37,16	20,92	46,21	25,93	21,47	38,62	38,62	22,26	39,94	35,64	22,59	43,13	24,92	23,15				
12000	24	48,95	48,95	17,66	49,04	49,04	17,70	52,00	42,89	18,13	46,79	46,79	19,33	46,84	46,84	19,36	49,27	41,97	19,78	44,47	44,47	21,05	44,51	44,51	21,08	46,39	40,55	21,46	41,98	41,97	22,80	42,01	42,01	22,83	43,36	39,47	23,14				
	27	44,90	44,90	18,13	48,50	32,49	18,68	52,62	19,25	19,18	42,64	42,64	19,70	45,92	31,52	20,29	49,77	18,32	20,82	40,30	40,30	21,34	43,21	30,52	21,95	46,76	17,34	22,51	37,78	37,78	22,99	40,29	29,44	23,61	43,60	16,33	24,18				
	29,5	46,71	46,71	18,26	48,65	42,62	18,65	52,61	29,92	19,18	44,58	44,57	19,90	46,11	41,60	20,26	49,76	20,83	20,83	42,31	42,31	21,60	43,44	40,53	21,92	46,77	28,02	22,51	39,83	39,82	23,32	40,59	39,38	23,58	43,61	27,01	24,18				
32	48,73	48,73	18,49	49,22	49,22	18,64	52,64	38,79	19,18	46,51	46,51	20,15	46,76																												

Cooling Capacities

TRAE (60Hz)

Tab. VI - 07 - Cooling Capacity - Solution Plus 150: DX150 with TRAE 150 - 2 Circuits

Air Flow (m3/h)	TEAE BS	Inlet Air Temperature on Condenser - BU (°C)																																			
		29,5						35						40,5						46																	
		Evaporator Entering Wet Bulb Temperature - BU (°C)																																			
		16		19,5		23		16		19,5		23		16		19,5		23		16		19,5		23													
°C		Total cap.	Sens. Cap.	KW	Total cap.	Sens. Cap.	KW	Total cap.	Sens. Cap.	KW	Total cap.	Sens. Cap.	KW	Total cap.	Sens. Cap.	KW	Total cap.	Sens. Cap.	KW	Total cap.	Sens. Cap.	KW	Total cap.	Sens. Cap.	KW												
6000	24	38,97	30,39	16,01	43,31	23,98	16,51	47,95	17,31	17,03	37,25	29,55	17,66	41,35	23,13	18,20	45,72	16,46	18,78	35,41	28,66	19,46	39,27	22,24	20,03	43,35	15,57	20,63	33,40	27,71	21,41	36,97	21,28	21,96	40,72	14,61	22,54
	27	38,98	35,62	16,01	43,29	29,26	16,51	47,94	22,64	17,03	37,26	34,78	17,66	41,34	28,41	18,20	45,71	21,80	18,78	35,43	33,90	19,47	39,25	27,52	20,03	43,33	20,91	20,63	33,43	32,95	21,42	36,96	26,56	21,96	40,72	19,94	22,54
	29,5	39,00	39,00	16,01	43,29	33,64	16,51	47,93	27,07	17,03	37,29	37,29	17,66	41,34	32,79	18,20	45,70	26,22	18,78	35,47	35,47	19,47	39,26	31,90	20,03	43,32	25,33	20,63	33,44	33,44	21,41	36,96	30,94	21,96	40,71	24,37	22,54
7800	24	41,28	35,02	16,67	45,70	26,68	17,19	50,37	18,06	17,71	39,34	34,13	18,33	43,50	25,79	18,90	47,89	17,17	19,47	37,28	33,19	20,14	41,17	24,85	20,72	45,23	16,24	21,32	35,03	32,18	22,06	38,61	23,84	22,63	42,34	15,24	23,21
	27	41,32	41,32	16,68	45,68	33,55	17,19	50,36	25,00	17,71	39,38	39,38	18,34	43,49	32,65	18,90	47,87	24,11	19,47	37,33	37,33	20,15	41,16	31,72	20,72	45,22	23,18	21,32	35,08	35,08	22,07	38,61	30,71	22,63	42,33	22,18	23,21
	29,5	41,35	41,35	16,67	45,69	39,24	17,19	50,35	30,75	17,71	39,42	39,42	18,33	43,51	38,35	18,90	47,86	29,87	19,47	37,40	37,40	20,13	41,18	37,42	20,72	45,21	28,94	21,32	35,29	35,29	22,05	38,64	36,41	22,64	42,32	27,94	23,21
10200	24	41,86	41,86	16,69	45,72	44,93	17,20	50,34	36,49	17,71	40,30	40,30	18,41	43,53	43,51	18,91	47,86	35,61	19,47	38,60	38,60	20,28	41,22	41,22	20,73	45,21	34,67	21,32	36,71	36,71	22,27	38,68	38,68	22,64	42,33	33,68	23,21
	27	43,38	43,38	17,75	47,76	39,09	18,28	52,38	27,99	18,80	41,24	41,24	19,42	45,35	38,16	20,00	49,66	27,07	20,58	38,99	38,99	21,20	42,80	37,18	21,82	46,79	26,11	22,43	36,58	36,58	23,09	40,03	36,14	23,71	43,69	25,10	24,30
	29,5	43,68	43,68	17,69	47,79	46,54	18,28	52,37	35,52	18,80	41,84	41,84	19,41	45,38	45,38	20,00	49,65	34,60	20,58	39,95	39,95	21,28	42,84	42,84	21,83	46,78	33,65	22,43	37,86	37,86	23,25	40,08	40,08	23,72	43,69	32,63	24,31
12000	24	44,41	45,41	17,90	47,84	47,84	18,29	52,37	43,02	18,81	43,58	43,58	19,65	45,43	45,43	20,01	49,66	42,11	20,58	41,62	41,62	21,53	42,88	42,88	21,83	46,80	41,15	22,43	39,44	39,44	23,50	40,14	40,14	23,70	43,71	40,14	24,31
	27	44,40	44,40	18,76	48,84	32,61	19,32	53,44	19,51	19,86	42,16	42,16	20,44	46,30	31,66	21,04	50,60	18,58	21,64	39,79	39,79	22,24	43,63	30,67	22,87	47,61	17,61	23,50	37,21	37,21	24,14	40,73	29,60	24,75	44,40	16,58	25,37
	29,5	44,48	44,48	18,75	48,86	43,18	19,32	53,42	30,18	19,86	42,27	42,27	20,40	46,32	42,23	21,05	50,58	29,25	21,65	39,99	39,99	22,17	43,66	41,23	22,87	47,59	28,28	23,50	37,66	37,66	24,07	40,77	40,17	24,75	44,38	27,25	25,37
12000	29,5	45,52	45,52	18,77	48,90	48,90	19,33	53,41	39,04	19,86	43,61	43,61	20,51	46,37	46,37	21,06	50,58	38,12	21,65	41,57	41,57	22,19	43,71	43,71	22,89	47,59	37,15	23,50	39,30	39,30	24,34	40,83	40,83	24,76	44,39	36,12	25,37
	32	47,42	47,42	19,00	48,95	48,95	19,34	53,43	47,88	19,87	45,43	45,43	20,77	46,43	46,43	21,04	50,60	46,95	21,65	43,31	43,30	22,66	43,82	43,82	22,84	47,62	45,98	23,51	40,95	40,95	24,61	41,07	41,07	24,69	44,42	44,42	25,38

Tab. VI - 08 - Cooling Capacity - Solution Plus 200: DX200 with TRAE 200 - 2 Circuits

Air Flow (m3/h)	TEAE BS	Inlet Air Temperature on Condenser - BU (°C)																																			
		29,5						35						40,5						46																	
		Evaporator Entering Wet Bulb Temperature - BU (°C)																																			
		16		19,5		23		16		19,5		23		16		19,5		23		16		19,5		23													
°C		Total cap.	Sens. Cap.	KW	Total cap.	Sens. Cap.	KW	Total cap.	Sens. Cap.	KW	Total cap.	Sens. Cap.	KW	Total cap.	Sens. Cap.	KW	Total cap.	Sens. Cap.	KW	Total cap.	Sens. Cap.	KW	Total cap.	Sens. Cap.	KW												
9000	24	51,20	42,07	19,52	56,36	32,29	20,16	61,67	22,12	20,81	48,83	40,96	21,43	53,70	31,19	22,11	58,70	21,04	22,81	46,28	39,78	23,50	50,85	30,02	24,19	55,50	19,90	24,90	43,56	38,53	25,72	47,82	28,80	26,39	52,13	18,72	27,07
	27	51,23	49,93	19,52	56,35	40,21	20,16	61,65	30,12	20,81	48,86	48,81	21,43	53,69	39,10	22,11	58,68	29,05	22,81	46,32	46,32	23,50	50,84	37,94	24,19	55,48	27,90	24,90	43,62	43,62	25,72	47,82	36,72	26,39	52,12	18,72	27,07
	29,5	51,34	51,34	19,51	56,35	46,78	20,17	61,64	36,76	20,81	49,07	49,07	21,42	53,70	45,68	22,11	58,67	35,69	22,81	46,72	46,72	23,50	50,85	44,51	24,20	55,47	34,55	24,91	44,43	44,43	25,78	47,84	43,30	26,39	52,10	18,72	27,07
11300	24	52,70	52,70	19,64	56,37	53,33	20,17	61,63	43,38	20,81	50,72	50,72	21,62	53,72	52,23	22,12	58,66	42,31	22,81	48,57	48,57	23,77	50,88	50,88	24,20	55,46	41,16	24,91	46,24	46,24	26,06	47,86	47,86	26,38	52,11	19,98	27,07
	27	53,43	47,81	20,39	58,55	35,57	21,04	63,78	22,92	21,69	50,84	46,65	22,30	55,64	34,42	22,99	60,59	21,82	23,70	48,09	45,43	24,37	52,57	33,23	25,07	57,16	20,65	25,79	45,15	44,14	26,56	49,33	31,98	27,24	53,57	19,45	27,94
	29,5	53,50	53,50	20,37	58,55	45,51	21,04	63,76	32,97	21,69	50,96	50,96	22,28	55,65	44,37	22,99	60,57	31,87	23,70	48,29	48,29	24,33	52,58	43,17	25,07	57,14	30,71	25,79	45,52	45,52	26,52	49,35	41,93	27,24	53,55	19,50	27,94
13600	24	54,96	54,96	20,68	58,60	58,60	21,04	63,75	49,62	21,69	54,35	54,35	22,68	55,74	55,74	22,98	60,56	48,52	23,70	51,90	51,90	24,83	52,74	52,74	25,05	57,14	47,36	25,80	49,26	49,26	27,09	49,61	49,61	27,21	53,55	46,15	27,94
	27	55,26	55,26	21,34	60,04	50,71	22,08	65,17	35,74	22,74	52,70	52,70	23,25	57,00	49,55	24,05	61,82	34,63	24,76	50,15	50,15	25,35	53,77	48,33	26,12	58,26	33,46	26,86	47,48	47,48	27,60	50,38	47,06	28,27	54,51	32,24	28,99
	29,5	57,24	57,24	21,54	60,06	60,06	22,09	65,16	45,78	22,74	54,83	54,83	23,53	57,02	57,02	24,05	61,82	44,67	24,76	52,24	52,24	25,67	53,80	53,80	26,10	58,25	43,50	26,86	49,47	49,47	27,92	50,45	50,45	28,23	54,50	42,28	28,99
17000	24	59,51	59,51	21,82	60,26	60,26	22,03	65,16	55,78	22,74	57,02	57,02	23,85	57,36	57,36	23,98	61,82	54,67	24,77	54,32	54,32	26,00	54,37	54,37	26,04	58,26	53,50	26,86	51,43	51,43	28,24	51,46	51,46	28,28	54,50	52,28	28,99
	27	56,52	56,52	23,35	61,53	43,34	24,08	66,61	24,67	24,77	53,63	53,63	25,24	58,33	42,16	26,05	63,10	23,55	26,81	50,60	50,60	27,25	54,93	49,92	28,12	59,39	22,36	28,91	47,45	47,45	29,37	51,38	39,64	30,26	55,49	21,14	31,03
	29,5	57,81	57,81	23,26	61,54	58,29	24,08	66,58	39,79	24,78	55,26	55,26	25,26	58,34	57,12	26,05	63,08	38,67	26,82	52,53	52,53	27,39	54,95	54,88	28,12	59,36	37,49	28,91	49,61	49,61	29,61	51,40	51,40	30,26	55,47	36,26	31,03
17000	29,5	60,21	60,21	23,58	61,59	61,59	24,02	66,57	52,34	24,78	57,56	57,56	25,61	58,46	58,46	25,97	63,07	51																			



Cooling Capacities

TRAE (60Hz)

Tab. VI - 09 - Cooling Capacity - Solution Plus 250: DX250 with TRAE 250 - 2 Circuits

Air Flow (m3/h)	TEAE BS	Inlet Air Temperature on Condenser - BU (°C)																																			
		29,5							35							40,5							46														
		Evaporator Entering Wet Bulb Temperature - BU (°C)																																			
		16	19,5	23	16	19,5	23	16	19,5	23	16	19,5	23	16	19,5	23	16	19,5	23	16	19,5	23	Total cap.	Sens. Cap.	KW												
°C	Total cap.	Sens. Cap.	KW	Total cap.	Sens. Cap.	KW	Total cap.	Sens. Cap.	KW	Total cap.	Sens. Cap.	KW	Total cap.	Sens. Cap.	KW	Total cap.	Sens. Cap.	KW	Total cap.	Sens. Cap.	KW	Total cap.	Sens. Cap.	KW													
12000	24	64,28	54,24	25,81	70,51	41,16	26,63	76,96	27,61	27,43	61,29	52,86	28,34	67,15	39,79	29,20	73,23	26,28	30,06	58,09	51,40	31,07	63,54	38,34	31,93	69,16	24,86	32,79	54,58	49,82	33,93	59,70	36,82	34,76	64,95	23,40	35,58
	27	64,35	64,04	25,81	70,52	51,72	26,63	76,94	27,61	27,43	61,36	52,86	28,34	67,16	40,35	29,20	73,20	26,28	30,06	58,06	51,40	31,07	63,56	38,34	31,93	69,14	24,86	32,79	54,75	54,75	33,92	59,74	36,82	34,76	64,93	23,40	35,58
	29,5	64,66	64,66	25,79	70,55	60,49	26,63	76,93	27,61	27,43	61,86	52,86	28,33	67,19	40,35	29,20	73,19	26,28	30,06	58,09	51,40	31,12	63,60	38,34	31,93	69,13	24,86	32,79	56,16	56,16	34,07	59,79	36,82	34,76	64,93	23,40	35,58
	32	66,74	66,74	26,02	70,60	68,46	26,64	76,93	27,61	27,43	64,19	52,86	28,33	67,23	40,35	29,21	73,20	26,28	30,06	61,42	61,41	31,47	63,65	38,34	31,93	69,15	24,86	32,79	58,40	58,40	34,42	59,88	36,82	34,76	64,95	23,40	35,58
15000	24	66,80	61,63	26,90	72,99	45,38	27,74	79,35	28,62	28,53	63,56	60,20	29,44	69,36	43,96	30,31	75,33	27,26	31,17	60,12	57,82	32,16	65,49	42,48	33,03	71,03	25,81	33,89	56,40	56,10	34,99	61,43	40,93	35,83	67,14	24,53	36,81
	27	66,96	66,96	26,87	73,02	58,58	27,74	79,32	28,62	28,53	63,82	63,82	29,40	69,39	43,96	30,31	75,31	27,26	31,17	60,51	60,51	32,10	65,54	42,48	33,03	71,01	25,81	33,89	57,14	57,14	34,94	61,48	40,93	35,83	67,13	24,53	36,81
	29,5	68,59	68,59	26,97	73,06	68,61	27,74	79,32	28,62	28,53	65,80	65,80	29,60	69,45	43,96	30,32	75,31	27,26	31,17	62,77	62,77	32,40	65,59	42,48	33,03	71,02	25,81	33,89	59,52	59,52	35,32	61,53	40,93	35,83	67,15	24,53	36,81
	32	71,29	71,29	27,32	73,16	73,16	27,72	79,33	28,62	28,53	68,39	68,39	29,97	73,32	43,96	30,31	75,32	27,26	31,17	65,24	65,24	32,78	65,86	42,48	33,03	71,04	25,81	33,89	61,86	61,86	35,69	62,01	40,93	35,83	67,18	24,53	36,82
17000	24	68,03	65,53	27,74	74,19	48,12	28,58	80,48	29,24	29,38	64,68	63,98	30,28	70,44	46,70	31,16	76,34	27,87	32,02	61,09	61,09	32,98	66,44	45,19	33,87	71,92	26,42	34,75	57,27	57,27	35,79	62,26	43,63	36,66	67,98	25,14	37,67
	27	68,43	68,43	27,66	74,22	63,08	28,58	80,46	29,24	29,38	65,27	65,27	30,17	70,48	46,70	31,17	76,32	27,87	32,02	62,10	62,10	32,92	66,49	45,19	33,87	71,90	26,42	34,75	58,77	58,77	35,83	62,31	43,63	36,66	67,97	25,14	37,67
	29,5	70,84	70,84	27,89	74,26	74,26	28,59	80,46	29,24	29,38	67,85	67,85	30,52	70,53	46,70	31,17	76,32	27,87	32,02	64,65	64,65	33,32	66,54	45,19	33,86	71,91	26,42	34,75	61,21	61,21	36,22	62,40	43,63	36,66	68,00	25,14	37,67
	32	73,61	73,61	28,25	74,52	74,52	28,51	80,46	29,24	29,38	70,53	70,53	30,91	70,94	46,70	31,16	76,33	27,87	32,02	67,17	67,17	33,71	67,24	45,19	33,77	71,92	26,42	34,75	63,61	63,61	36,60	63,65	43,63	36,66	68,03	25,14	37,67
21000	24	69,85	69,85	29,76	75,94	53,53	30,64	82,13	30,45	31,47	66,30	66,30	32,27	72,01	52,08	33,23	77,82	29,07	34,13	62,56	62,56	34,91	67,82	45,19	33,93	73,22	27,61	36,85	58,65	58,65	37,66	63,46	48,98	38,70	69,20	26,34	39,78
	27	71,34	71,34	29,62	75,97	70,67	30,65	82,11	30,45	31,48	68,20	68,20	32,24	72,06	52,08	33,24	77,79	29,07	34,14	64,83	64,83	35,02	67,86	45,19	34,04	73,20	27,61	36,86	61,24	61,24	37,90	63,51	48,98	38,71	69,20	26,34	39,78
	29,5	74,25	74,25	30,01	76,03	76,03	30,59	82,10	30,45	31,47	71,01	71,01	32,66	72,18	52,08	33,14	77,79	29,07	34,13	67,47	67,47	35,45	68,07	45,19	34,07	73,20	27,61	36,85	63,75	63,75	38,32	63,91	48,98	38,48	69,23	26,34	39,78
	32	77,15	77,15	30,38	77,19	77,19	30,44	82,10	30,45	31,47	73,77	73,77	33,07	73,81	52,08	33,13	77,79	29,07	34,13	70,10	70,10	35,87	70,13	45,19	33,93	73,18	27,61	36,85	66,48	66,48	38,80	66,52	48,98	38,86	69,24	26,34	39,78

Tab. VI - 10 - Cooling Capacity - Solution Plus 300: DX300 with TRAE 300 - 2 Circuits

Air Flow (m3/h)	TEAE BS	Inlet Air Temperature on Condenser - BU (°C)																																			
		29,5							35							40,5							46														
		Evaporator Entering Wet Bulb Temperature - BU (°C)																																			
		16	19,5	23	16	19,5	23	16	19,5	23	16	19,5	23	16	19,5	23	16	19,5	23	16	19,5	23	Total cap.	Sens. Cap.	KW												
°C	Total cap.	Sens. Cap.	KW	Total cap.	Sens. Cap.	KW	Total cap.	Sens. Cap.	KW	Total cap.	Sens. Cap.	KW	Total cap.	Sens. Cap.	KW	Total cap.	Sens. Cap.	KW	Total cap.	Sens. Cap.	KW	Total cap.	Sens. Cap.	KW													
15000	24	83,71	69,37	31,75	92,30	53,16	32,57	101,40	36,38	33,40	79,73	67,51	34,81	87,76	51,28	35,72	96,29	34,53	36,63	75,50	65,56	38,02	82,96	49,33	39,00	90,83	32,60	39,97	70,93	63,48	41,34	77,75	42,35	42,35	84,93	30,54	43,34
	27	83,80	81,74	31,76	92,29	66,35	32,58	101,37	49,72	33,40	79,83	79,80	34,82	87,76	64,48	35,72	96,26	47,88	36,63	75,60	75,60	38,03	82,97	62,54	39,00	90,80	32,60	39,97	71,06	61,06	41,33	77,78	60,46	42,36	84,90	43,88	43,34
	29,5	84,07	84,07	31,73	92,33	77,32	32,58	101,35	60,79	33,41	80,26	80,26	34,79	87,81	75,45	35,72	96,24	58,95	36,63	76,36	76,36	38,02	83,02	73,50	39,01	90,79	32,60	39,97	72,47	72,47	41,45	77,85	71,42	42,37	84,90	54,95	43,35
	32	86,34	86,34	31,88	92,39	88,25	32,58	101,35	71,82	33,41	83,01	83,01	35,06	87,88	86,38	35,73	96,25	69,98	36,64	79,40	79,40	38,41	83,10	83,10	39,02	90,81	32,60	39,98	75,40	75,40	41,88	77,94	77,94	42,37	84,93	65,99	43,35
18000	24	86,68	76,88	32,87	95,29	57,48	33,71	104,36	37,49	34,55	82,40	74,96	35,95	90,43	55,56	36,87	98,91	35,60	37,79	77,85	72,93	39,17	85,27	53,54	40,16	93,11	33,62	41,13	72,97	69,81	42,49	79,76	51,41	43,51	86,88	31,52	44,50
	27	86,81	86,81	32,86	95,32	73,33	33,72	104,33	53,50	34,56	82,59	82,59	35,93	90,47	71,41	36,88	98,88	51,61	37,80	78,14	78,14	39,14	85,32	69,39	40,16	93,08	33,62	41,14	73,43	73,43	42,44	79,82	67,26	43,52	86,85	47,53	44,50
	29,5	87,95	87,95	32,82	95,38	86,49	33,73	104,32	66,78	34,56	84,37	84,37	36,00	90,54	84,57	36,89	98,88	64,90	37,80	80,49	80,49	39,35	85,39	82,55	40,17	93,09	33,62	41,14	76,23	76,23	42,80	79,91	79,14	43,53	86,87	60,82	44,51
	32	91,56	91,55	33,17	95,47	95,47	33,73	104,35	80,03	34,56	87,81	87,80	36,38	90,66	90,66	36,88	98,91	78,14	37,80	83,76	83,76	39,76	85,57	85,57	40,15	93,13	33,62	41,15	79,34	79,34	43,24	80,22	43,48	86,91	74,07	44,51	
20400	24	88,49	82,77	33,90	97,11	60,86	34,76	106,15	38,31	35,62	84,04	80,81	37,00	92,05	58,90	37,93	100,48	36,39	38,87	79,30	77,60	40,23	86,67	56,84	41,22	94,48	34,39	42,21	74,21	74,21	43,54	80,97	54,69	44,57	88,03	32,27	45,57
	27	88,77	88,77	33,85	97,16	78,82	34,77	106,12	56,45	35,62	84,44	84,44	36,92	92,11	76,86	37,94	100,45	54,54	38,87	79,95	79,95	40,13	86,75	74,81	41,23	94,45	34,39	42,22	75,41	75,41	43,49	81,05	72,65	44,58	88,01	50,41	45,57
	29,5	91,17	91,16	33,94	97,23	93,73	34,78	106,12	71,52	35,63	87,30	87,30	37,14	92,19	90,44	37,95	100,45	69,60	38,88	83,15	83,15	40,50	86,84	86,84	41,24	94,47	34,39	42,22	78,62	78,62	43,96	81,14	81,14	44,58	88,07	65,49	45,58
	32	94,91	94,91	34,29	97,40	97,40	34,74	106,16	86,53	35,63	90,90	90,90	37,54	92,46	92,46	37,90	100,50	84,61	38,88	86,56	86,56	40,93	87,29	87,29	41,16	94,52	34,39	42,23	81,82	81,82	44,41	81,94	81,94	44,48	88,12	80,50	45,59
25000	24	91,12	91,12	36,33	99,69	67,18	37,25	108,67	39,79	38,16	86,35	86,35	39,44	94,34	65,18	40,43	102,68	37,83	41,41	81,35	81,35	42,66	88,69	63,09	43,72	96,40	35,80	44,76	76,01	76,01	45,91	82,68	60,89	47,06	89,6		



Cooling Capacities

TRAE (60Hz)

Tab. VI - 11 - Cooling Capacity - Solution Plus 300: DX300 with TRAE 300 with TRAE 150 + TRAE150 - 2 Circuit

Vazão de Ar (m³/h)	TEAE BS	Temperatura de Entrada de Ar no Condensador - BU (°C)																																			
		29,5									35									40,5									46								
		Temperatura Bulbo Úmido Entrada do Evaporador - BU (°C)																																			
		16			19,5			23			16			19,5			23			16			19,5			23			16			19,5			23		
°C	Total cap.	Sens. Cap.	KW	Total cap.	Sens. Cap.	KW	Total cap.	Sens. Cap.	KW	Total cap.	Sens. Cap.	KW	Total cap.	Sens. Cap.	KW	Total cap.	Sens. Cap.	KW	Total cap.	Sens. Cap.	KW	Total cap.	Sens. Cap.	KW	Total cap.	Sens. Cap.	KW	Total cap.	Sens. Cap.	KW	Total cap.	Sens. Cap.	KW				
15000	24	83,18	69,12	32,36	91,52	52,83	33,29	100,23	35,96	34,21	79,27	67,29	35,49	87,19	51,05	36,53	95,41	34,22	37,54	75,14	65,39	38,77	82,57	49,18	39,89	90,24	32,39	40,97	70,67	63,36	42,21	77,46	47,13	43,26	84,59	30,42	44,37
	27	83,26	81,48	32,37	91,52	66,03	33,29	100,20	49,30	34,21	79,36	79,36	35,51	87,20	64,25	36,53	95,38	47,56	37,54	75,25	75,25	38,78	82,59	62,38	39,90	90,21	45,73	40,97	70,81	70,81	42,20	77,46	60,33	43,26	84,56	43,76	44,37
	29,5	83,54	83,54	32,35	91,56	77,00	33,30	100,18	60,37	34,21	79,82	79,82	35,49	87,24	75,22	36,54	95,36	58,63	37,55	76,05	76,05	38,80	82,65	73,35	39,90	90,19	56,80	40,97	72,27	72,27	42,33	77,53	71,30	43,27	84,55	54,83	44,38
18000	24	86,06	76,60	33,52	94,40	57,13	34,47	103,04	37,02	35,38	81,90	74,73	36,68	89,76	55,30	37,72	97,89	35,25	38,73	77,48	72,76	39,97	84,86	53,38	41,09	92,41	33,38	42,16	72,71	69,69	43,37	79,42	51,28	44,44	86,50	31,39	45,56
	27	86,20	86,20	33,52	94,42	72,97	34,47	103,01	53,03	35,39	82,10	82,10	36,67	89,79	71,14	37,73	97,86	51,26	38,73	77,77	77,77	39,94	84,91	69,23	41,10	92,38	49,39	42,16	73,19	73,19	43,31	79,50	67,14	44,46	86,47	47,40	45,56
	29,5	87,42	87,42	33,51	94,47	86,13	34,47	102,99	66,32	35,39	83,93	83,93	36,78	89,85	84,29	37,73	97,85	64,55	38,74	80,17	80,17	40,20	84,98	82,39	41,11	92,38	62,68	42,16	75,98	75,98	43,69	79,60	79,02	44,48	86,49	60,70	45,57
20400	24	87,83	82,47	34,58	96,13	60,47	35,53	104,71	37,82	36,46	83,51	80,58	37,75	91,31	58,61	38,80	99,38	36,02	39,82	78,90	77,42	41,05	86,24	56,68	42,17	93,72	34,14	43,25	73,94	73,94	44,42	80,63	54,56	45,53	87,64	32,14	46,64
	27	88,10	88,10	34,53	96,16	78,43	35,54	104,67	55,96	36,47	83,93	83,93	37,68	91,35	76,57	38,80	99,35	54,17	39,82	79,59	79,59	40,96	86,29	74,63	42,18	93,69	52,28	43,25	75,18	75,18	44,37	80,72	72,53	45,54	87,61	50,28	46,65
	29,5	90,51	90,51	34,65	96,22	93,34	35,54	104,67	71,02	36,47	86,80	86,80	37,96	91,43	90,13	38,82	99,35	69,23	39,83	82,83	82,83	41,41	86,36	86,36	42,19	93,70	67,35	43,26	78,37	78,37	44,89	80,82	80,82	45,54	87,66	65,36	46,66
25000	24	90,91	90,91	33,89	94,54	94,54	34,47	103,01	79,56	35,39	87,31	87,31	37,21	89,95	89,95	37,72	97,88	77,79	38,74	83,44	83,44	40,68	85,15	85,15	41,08	92,41	75,92	42,17	79,09	79,09	44,19	79,92	79,92	44,44	86,55	73,95	45,58
	27	91,35	91,35	36,81	98,62	88,76	38,04	107,00	61,49	39,02	87,38	87,38	40,09	93,58	86,88	41,33	101,44	59,68	42,40	83,19	83,19	43,52	88,25	83,30	44,72	95,52	57,77	45,83	78,51	78,51	46,98	82,44	80,96	48,07	89,24	55,77	49,22
	29,5	95,13	95,13	37,22	98,68	98,68	38,05	107,01	79,95	39,03	91,05	91,05	40,57	93,66	93,66	41,30	101,45	78,14	42,40	86,69	86,69	44,04	88,38	88,38	44,64	95,53	76,23	45,83	81,85	81,85	47,53	82,71	82,71	47,94	89,30	74,24	49,23
	32	98,93	98,92	37,64	99,36	99,36	37,84	107,04	98,34	39,03	94,71	94,71	41,04	94,77	94,77	41,08	101,48	96,53	42,40	90,15	90,15	44,55	90,20	90,20	44,63	95,54	92,58	45,83	85,18	85,18	48,07	85,23	85,23	48,15	89,35	89,35	49,25

Tab. VI - 12 - Cooling Capacity - Solution Plus 350: DX350 with TRAE 150 + TRAE 200 - 2 Circuits

Air Flow (m³/h)	TEAE BS	Inlet Air Temperature on Condenser - BU (°C)																																			
		29,5									35									40,5									46								
		Evaporator Entering Wet Bulb Temperature - BU (°C)																																			
		16			19,5			23			16			19,5			23			16			19,5			23			16			19,5			23		
°C	Total cap.	Sens. Cap.	KW	Total cap.	Sens. Cap.	KW	Total cap.	Sens. Cap.	KW	Total cap.	Sens. Cap.	KW	Total cap.	Sens. Cap.	KW	Total cap.	Sens. Cap.	KW	Total cap.	Sens. Cap.	KW	Total cap.	Sens. Cap.	KW	Total cap.	Sens. Cap.	KW	Total cap.	Sens. Cap.	KW	Total cap.	Sens. Cap.	KW	Total cap.	Sens. Cap.	KW	
17500	24	96,70	80,54	39,09	106,21	61,47	40,39	116,05	41,69	41,71	92,18	78,43	42,80	101,14	59,38	44,20	110,40	39,66	45,62	87,37	76,21	46,73	95,72	57,18	48,17	104,35	37,51	49,64	82,21	73,86	50,87	89,91	54,85	52,25	97,83	35,23	53,65
	27	96,76	93,64	39,09	106,21	76,87	40,39	116,02	57,25	41,72	92,24	90,17	42,78	101,15	74,78	44,20	110,37	55,22	45,62	87,45	85,97	46,68	95,74	72,58	48,17	104,32	53,07	49,64	82,35	81,65	50,77	89,94	70,26	52,25	97,79	50,80	53,65
	29,5	97,35	97,35	39,03	106,24	89,65	40,40	116,00	70,17	41,72	93,24	93,24	42,81	101,19	87,57	44,21	110,35	68,14	45,62	88,83	88,83	46,80	95,80	85,37	48,18	104,31	65,99	49,64	84,11	84,11	50,99	90,00	82,51	52,26	97,80	63,72	53,65
22000	24	99,81	99,81	39,30	106,29	101,24	40,40	115,99	83,04	41,72	96,01	96,01	43,18	101,22	97,58	44,20	110,35	81,01	45,62	91,88	91,88	47,28	95,84	93,62	48,15	104,32	78,86	49,65	87,36	87,36	51,54	90,08	88,59	52,19	97,83	76,60	53,66
	27	100,98	100,98	40,88	110,26	87,20	42,32	119,88	62,79	43,65	96,32	96,32	44,60	104,77	85,05	46,14	113,81	60,72	47,57	91,47	91,47	48,57	98,97	82,79	50,11	107,35	58,53	51,59	86,27	86,27	52,69	92,62	80,40	54,13	100,44	56,23	55,56
	29,5	103,07	103,07	41,02	110,31	102,63	42,33	119,87	79,03	43,66	98,77	98,77	44,85	104,83	99,70	46,15	113,80	76,96	47,58	94,25	94,25	48,94	99,04	95,65	50,11	107,35	74,77	51,59	89,32	89,32	53,15	92,79	91,13	54,09	100,46	72,47	55,57
23800	24	106,99	106,99	41,51	110,40	109,57	42,24	119,87	95,21	43,66	102,64	102,64	45,45	105,04	105,04	46,02	113,82	93,14	47,58	97,99	97,99	49,57	99,65	99,65	50,02	107,36	90,95	51,59	92,83	92,83	53,76	93,84	93,84	54,09	100,50	88,66	55,57
	27	102,03	95,49	41,83	111,45	70,33	43,17	121,08	43,80	44,51	97,00	92,61	45,56	105,81	68,15	46,99	114,87	41,71	48,44	91,63	88,77	49,46	99,87	65,88	50,95	108,29	39,52	52,44	85,93	83,86	53,50	93,49	63,47	54,97	101,82	37,39	56,54
	29,5	102,50	102,50	41,67	111,48	91,28	43,18	121,04	64,97	44,52	97,84	97,84	45,45	105,87	89,10	47,00	114,84	62,88	48,44	92,87	92,87	49,42	99,94	86,84	50,97	108,25	60,69	52,45	87,55	87,55	53,52	93,56	83,69	54,97	101,23	58,38	56,41
31000	24	109,28	109,28	42,45	111,77	111,77	43,02	121,04	100,04	44,52	104,75	104,75	46,40	106,54	106,54	46,87	114,84	97,95	48,45	99,90	99,90	50,53	101,05	101,05	50,90	108,26	95,76	52,46	94,55	94,55	54,70	95,13	95,13	54,95	101,28	92,53	56,43
	27	105,67	104,87	45,79	114,96	80,11	47,30	124,42	46,01	48,73	100,28	100,28	49,49	108,97	77,89	51,14	117,81	43,88	52,66	94,49	94,49	53,18	102,65	75,57	55,09	110,87	41,66	56,67	88,74	88,74	57,25	95,89	73,12	59,06	104,21	39,56	60,77
	29,5	107,68	107,67	45,64	115,00	106,45	47,31	124,38	73,59	48,74	102,72	102,72	49,42	109,03	103,42	51,16	117,77	71,45	52,67	97,71	97,71	53,48	102,71	99,32	55,11	110,84	69,24	56,68	92,19	92,19	57,62	95,95	93,51	59,03	104,21	67,14	60,78
	32	116,21	116,21	46,75	116,87	116,87	47,09	124,37	117,25	48,75	111,13	111,13	50,75	111,36	111,36	50,97	117,76	113,13	52,68	105,64	105,64	54,89	105,69	105,69	55,00	110,80	107,30										



Cooling Capacities

TRAE (60Hz)

Tab. VI - 13 - Cooling Capacity - Solution Plus 400: DX400 with TRAE 200 + TRAE 200 - 2 Circuits

Air Flow (m ³ /h)	TEAE BS	Inlet Air Temperature on Condenser - BU (°C)																																							
		29.5									35									40.5									46												
		Evaporator Entering Wet Bulb Temperature - BU (°C)						16						19.5						23						16						19.5						23			
°C	Total cap.	Sens Cap.	KW	Total cap.	Sens Cap.	KW	Total cap.	Sens Cap.	KW	Total cap.	Sens Cap.	KW	Total cap.	Sens Cap.	KW	Total cap.	Sens Cap.	KW	Total cap.	Sens Cap.	KW	Total cap.	Sens Cap.	KW	Total cap.	Sens Cap.	KW	Total cap.	Sens Cap.	KW											
20000	24	110.93	92.17	45.55	121.56	70.25	47.23	132.49	47.53	48.97	105.76	89.76	49.84	115.73	67.85	51.61	125.95	45.18	53.45	100.25	87.22	54.38	109.50	65.33	56.18	118.94	42.70	58.03	94.26	84.50	59.07	102.91	62.70	60.84	112.60	40.49	62.88				
20000	27	111.03	108.64	45.57	121.56	87.85	47.24	132.46	65.31	48.97	105.86	105.86	49.85	115.73	85.45	51.61	125.92	62.97	53.45	100.37	100.37	54.39	109.51	82.93	56.18	118.90	60.49	58.03	94.45	94.45	59.06	102.94	80.30	60.85	111.67	57.97	62.66				
20000	32	114.47	114.46	45.93	121.65	117.03	47.26	132.43	94.78	48.98	110.06	110.06	50.42	115.83	113.37	51.63	125.90	92.44	53.45	105.30	105.30	55.17	109.63	109.63	56.21	118.89	89.96	58.04	100.14	100.14	60.08	103.11	103.11	60.86	111.68	87.45	62.67				
24500	24	115.01	103.30	47.49	125.54	76.59	49.21	136.29	49.03	50.96	109.41	100.80	51.79	119.25	74.12	53.58	129.32	46.64	55.44	103.50	98.18	56.32	112.60	71.53	58.13	121.85	44.11	60.00	97.15	94.01	60.97	105.64	68.86	62.76	115.37	41.94	64.85				
24500	27	115.18	115.18	47.47	125.57	98.15	49.22	136.25	70.82	50.97	109.67	109.67	51.75	119.27	95.67	53.59	129.28	68.43	55.44	103.92	103.92	56.26	112.64	93.09	58.14	121.81	65.90	60.00	97.90	97.90	60.90	105.71	90.43	62.77	115.33	63.73	64.85				
24500	32	121.68	121.68	48.29	125.72	125.72	49.22	136.23	106.92	50.97	116.69	116.69	52.82	119.49	119.49	53.57	129.28	104.53	55.45	111.33	111.33	57.57	112.98	112.98	58.11	121.83	102.01	60.02	105.61	105.61	62.44	106.28	106.28	62.72	115.41	99.85	64.88				
27200	24	116.85	109.85	48.77	127.33	80.31	50.51	137.97	49.87	52.27	111.07	105.92	53.07	120.83	77.80	54.88	130.81	47.46	56.76	104.97	103.10	57.59	113.99	75.19	59.42	123.16	44.92	61.31	98.44	98.44	62.22	106.87	72.51	64.03	116.61	42.77	66.16				
27200	27	117.20	117.20	48.69	127.37	104.24	50.52	137.92	74.06	52.28	111.63	111.63	52.97	120.88	101.74	54.90	130.77	71.66	56.76	105.86	105.86	57.46	114.05	99.13	59.44	123.12	69.12	61.32	100.15	100.15	62.24	106.94	96.44	64.05	116.58	66.97	66.17				
27200	32	125.11	125.11	49.77	127.65	127.65	50.47	137.92	114.14	52.29	119.85	119.85	54.32	121.33	121.33	54.83	130.77	111.74	56.77	114.18	114.18	59.07	114.75	114.75	59.35	123.16	109.20	61.34	108.17	108.17	63.91	108.24	108.24	63.99	116.67	107.07	66.20				
35000	24	120.71	120.71	53.22	131.03	90.86	55.06	141.42	52.21	56.91	114.52	114.52	57.50	124.15	88.32	59.45	133.87	49.78	61.41	108.01	108.01	61.92	116.88	85.65	63.97	125.86	47.22	65.95	101.24	101.24	66.43	109.39	82.93	68.53	119.17	45.11	70.80				
35000	27	122.76	122.76	52.99	131.07	121.65	55.07	141.38	83.35	56.93	117.30	117.29	57.47	124.21	116.92	59.47	133.83	80.91	61.42	111.47	111.47	62.16	116.94	114.00	63.99	125.82	78.36	65.97	105.31	105.31	66.95	109.46	109.46	68.56	119.16	76.25	70.81				
35000	32	132.52	132.52	54.63	132.60	132.60	54.70	141.34	134.91	56.93	126.63	126.62	59.24	126.69	126.69	59.37	133.80	129.68	61.44	120.23	120.23	63.98	120.29	120.29	64.11	125.80	125.80	65.99	114.61	114.61	69.00	114.67	69.13	119.24	119.24	70.86					

Tab. VI - 14 - Cooling Capacity - Solution Plus 500: DX500 with TRAE 250 + TRAE 250 - 2 Circuits

Air Flow (m ³ /h)	TEAE BS	Inlet Air Temperature on Condenser - BU (°C)																																							
		29.5									35									40.5									46												
		Evaporator Entering Wet Bulb Temperature - BU (°C)						16						19.5						23						16						19.5						23			
°C	Total cap.	Sens Cap.	KW	Total cap.	Sens Cap.	KW	Total cap.	Sens Cap.	KW	Total cap.	Sens Cap.	KW	Total cap.	Sens Cap.	KW	Total cap.	Sens Cap.	KW	Total cap.	Sens Cap.	KW	Total cap.	Sens Cap.	KW	Total cap.	Sens Cap.	KW	Total cap.	Sens Cap.	KW	Total cap.	Sens Cap.	KW								
25000	24	132.79	112.47	56.05	145.27	85.06	58.11	158.02	56.68	60.21	126.55	109.59	61.39	138.23	82.21	63.55	150.19	53.91	65.76	119.91	106.57	67.13	130.76	79.22	69.31	141.87	51.00	71.56	112.75	103.35	73.12	122.88	76.11	75.27	134.48	48.46	77.80				
25000	27	132.90	132.90	56.06	145.26	107.06	58.12	157.97	78.91	60.21	126.68	126.68	61.41	138.25	104.21	63.56	150.15	76.14	65.76	120.07	120.07	67.13	130.79	101.22	69.32	141.83	73.24	71.57	113.04	113.04	73.10	122.93	98.11	75.28	134.44	70.69	77.80				
25000	32	137.83	137.82	56.65	145.38	141.99	58.14	157.94	115.75	60.22	132.42	132.42	62.23	138.39	138.39	63.58	150.13	112.98	65.77	126.63	126.63	68.23	130.95	130.95	69.33	141.83	110.08	71.57	120.37	120.37	74.47	123.16	123.16	75.27	134.48	107.54	77.82				
29500	24	136.60	123.54	58.23	148.94	91.35	60.33	161.52	58.14	62.45	129.96	120.58	63.58	141.54	88.44	65.77	153.31	55.34	68.00	122.92	117.47	69.30	133.67	85.39	71.52	144.61	52.40	73.79	115.43	112.47	75.25	125.43	82.24	77.43	137.09	49.89	80.03				
29500	27	136.82	136.82	58.21	148.97	117.30	60.33	161.47	84.38	62.45	130.28	130.28	63.53	141.58	114.40	65.79	153.26	81.58	68.01	123.44	123.44	69.22	133.72	111.35	71.53	144.57	78.64	73.80	116.36	116.36	75.17	125.49	108.20	77.44	137.04	76.13	80.03				
29500	32	144.58	144.58	59.24	149.13	149.13	60.33	161.45	127.85	62.46	138.68	138.68	64.87	141.84	141.84	65.76	153.26	125.05	68.02	132.30	132.30	70.86	134.11	134.11	71.47	144.58	122.11	73.81	125.50	125.50	77.05	126.20	126.20	77.37	137.11	119.61	80.06				
34000	24	139.47	134.42	60.69	151.71	97.50	62.83	164.12	59.53	64.99	132.53	129.51	66.05	144.02	94.57	68.29	155.64	56.71	70.56	125.20	125.20	71.75	135.84	91.48	74.02	146.65	53.75	76.34	117.43	117.43	77.68	127.34	88.30	79.90	139.03	51.27	82.58				
34000	27	140.04	140.04	60.57	151.75	127.42	62.85	164.06	89.77	65.00	133.38	133.38	65.88	144.07	124.49	68.30	155.59	86.95	70.57	126.71	126.70	71.63	135.88	121.39	74.03	146.61	84.00	76.34	119.97	119.97	77.79	127.41	118.21	79.91	139.00	81.52	82.59				
34000	32	149.90	149.90	62.03	152.16	152.16	62.75	164.05	139.87	65.01	143.58	143.58	67.69	144.74	144.74	68.18	155.58	137.04	70.58	136.71	136.71	73.67	136.98	136.98	73.86	146.57	134.08	76.34	129.47	129.47	79.83	129.55	129.55	79.95	139.07	131.63	82.61				
40000	24	142.37	142.37	64.60	154.46	105.60	66.81	166.71	61.32	69.06	135.08	135.08	69.94	146.50	102.64	72.28	157.95	58.48	74.64	127.48	127.48	75.57	137.99	99.50	77.99	148.64	55.50	80.39	119.53	119.53	81.38	129.25	96.31	83.85	140.98	53.06	86.65				
40000	27	144.09	144.09	64.26	154.51	140.80	66.83	166.66	96.91	69.07	137.78	137.77	69.85	146.55	137.83	72.30	157.90	94.07	74.65	131.02	131.01	75.76	138.05	131.99	78.01	148.59	91.08	80.40	123.84	123.83	81.88	129.31	128.47	83.87	140.96	88.65	86.67				
40000	32	155.44	155.44	66.25	155.79	155.79	66.50	166.61	155.83	69.07	148.64	148.63	71.95	148.72	148.72	72.12	157.87	151.44	74.66	141.30	141.30	77.94	141.38	141.37	78.10	148.55	146.56	80.42	134.79	134.79	84.37	134.87	134.86	84.54	141.02	141.02	86.70				

- Notes:
 (1)TEAE - Inlet air temperature on evaporator;
 (2)BS - Dry Bulb;
 (3)BU - Humid Bulb;
 (4)Consumption values refers only to condensers units;
 (5)Capacity do not include heat effect of motor on evaporator;
 (6)Capacities are based on 15m max. linear and 10m max. gap between evaporator and condenser unit;
 (7)Total and sensitive capacity: Mkc/h;
 (8)Heat generated by fan motor and fan performance table. MBH = Mkc/h x 3.9682.10⁻⁶;
 Cap. Total => 0.96
 Cap. Sens. => 0.98
 kW => 1.01

Cooling Capacities

TRCE (60Hz)

Tab. VI - 15 - Cooling Capacity - Solution Plus 050 - DX050 with TRCE 050 - 1 Circuit

Air Flow (m3/h)	TEAE BS	Inlet Air Temperature on Condenser - BU (°C)																																			
		29.5									35									40.5									46								
		Evaporator Entering Wet Bulb Temperature - BU (°C)																																			
°C	16			19.5			23			16			19.5			23			16			19.5			23			16			19.5			23			
	Total cap.	Sens Cap.	KW	Total cap.	Sens Cap.	KW	Total cap.	Sens Cap.	KW	Total cap.	Sens Cap.	KW	Total cap.	Sens Cap.	KW	Total cap.	Sens Cap.	KW	Total cap.	Sens Cap.	KW	Total cap.	Sens Cap.	KW	Total cap.	Sens Cap.	KW	Total cap.	Sens Cap.	KW							
2000	24	13.05	10.16	5.86	14.51	8.03	5.92	16.02	5.79	5.97	12.54	9.91	6.34	13.95	7.78	6.40	15.39	5.54	6.46	11.96	9.63	6.84	13.32	7.51	6.91	14.69	5.28	6.97	11.30	9.32	7.37	12.61	7.21	7.44	13.90	4.99	7.50
	27	13.05	11.91	5.86	14.51	9.79	5.92	16.02	7.56	5.97	12.55	11.66	6.34	13.95	9.54	6.40	15.38	7.32	6.46	11.97	11.38	6.84	13.32	9.27	6.91	14.68	7.06	6.97	11.31	11.06	7.37	12.60	8.97	7.44	13.90	6.77	7.50
	29.5	13.06	13.06	5.86	14.50	11.25	5.92	16.01	9.04	5.97	12.56	12.56	6.34	13.95	11.00	6.40	15.38	8.80	6.46	11.99	11.99	6.84	13.32	10.73	6.91	14.68	8.54	6.97	11.32	11.32	7.37	12.61	10.43	7.44	13.89	8.24	7.50
2600	24	13.84	11.71	6.00	15.31	8.93	6.06	16.79	6.02	6.12	13.28	11.45	6.48	14.68	8.67	6.55	16.08	5.77	6.61	12.64	11.16	6.99	13.99	8.39	7.06	15.31	5.50	7.12	11.92	10.84	7.52	13.20	8.08	7.59	14.45	5.20	7.65
	27	13.85	13.85	6.00	15.30	11.21	6.06	16.79	8.33	6.12	13.29	13.29	6.48	14.68	10.96	6.55	16.08	8.08	6.61	12.66	12.66	6.99	13.98	10.68	7.06	15.31	7.81	7.12	11.94	11.94	7.52	13.20	10.37	7.59	14.45	7.51	7.65
	29.5	13.86	13.86	6.00	15.31	13.11	6.06	16.79	10.25	6.12	13.30	13.30	6.48	14.68	12.86	6.55	16.07	10.00	6.61	12.68	12.68	6.98	13.99	12.58	7.06	15.31	9.73	7.12	11.99	11.99	7.51	13.21	12.27	7.59	14.45	9.43	7.65
3400	24	14.53	13.70	6.27	15.98	10.06	6.33	17.44	6.30	6.40	13.92	13.43	6.75	15.29	9.80	6.82	16.66	6.03	6.89	13.23	13.13	7.26	14.54	9.51	7.33	15.83	5.76	7.40	12.46	12.46	7.78	13.70	9.19	7.86	14.90	5.45	7.92
	27	14.55	14.55	6.27	15.98	13.05	6.33	17.43	9.32	6.40	13.94	13.94	6.75	15.29	12.79	6.82	16.65	9.06	6.89	13.25	13.25	7.25	14.54	12.50	7.33	15.82	8.78	7.40	12.49	12.49	7.77	13.71	12.18	7.86	14.90	8.48	7.92
	29.5	14.63	14.63	6.25	15.99	15.54	6.33	17.43	11.83	6.40	14.09	14.09	6.73	15.30	15.27	6.82	16.65	11.57	6.89	13.52	13.52	7.24	14.55	14.55	7.33	15.82	11.29	7.40	12.87	12.87	7.78	13.71	13.71	7.86	14.90	10.99	7.92
4000	24	15.18	15.18	6.27	16.00	16.00	6.33	17.43	14.33	6.40	14.66	14.66	6.76	15.31	15.31	6.82	16.65	14.07	6.89	14.08	14.08	7.27	14.56	14.56	7.33	15.82	13.79	7.40	13.41	13.41	7.81	13.72	13.72	7.85	14.89	13.49	7.92
	27	14.90	14.90	6.54	16.33	10.89	6.62	17.76	6.49	6.69	14.25	14.25	7.03	15.61	10.62	7.10	16.95	6.22	7.18	13.54	13.54	7.53	14.83	10.33	7.61	16.09	5.94	7.69	12.74	12.74	8.06	13.96	10.01	8.14	15.13	5.63	8.21
	29.5	14.92	14.92	6.54	16.33	14.41	6.62	17.76	10.65	6.69	14.28	14.28	7.01	15.61	14.14	7.10	16.94	9.78	7.18	13.49	13.49	7.49	14.83	13.85	7.61	16.08	9.50	7.69	12.82	12.82	8.03	13.96	13.53	8.14	15.13	9.19	8.21

Tab. VI - 16 - Cooling Capacity - Solution Plus 075 - DX075 with TRCE 075 - 1 Circuit

Air Flow (m3/h)	TEAE BS	Inlet Air Temperature on Condenser - BU (°C)																																			
		29.5									35									40.5									46								
		Evaporator Entering Wet Bulb Temperature - BU (°C)																																			
°C	16			19.5			23			16			19.5			23			16			19.5			23			16			19.5			23			
	Total cap.	Sens Cap.	KW	Total cap.	Sens Cap.	KW	Total cap.	Sens Cap.	KW	Total cap.	Sens Cap.	KW	Total cap.	Sens Cap.	KW	Total cap.	Sens Cap.	KW	Total cap.	Sens Cap.	KW	Total cap.	Sens Cap.	KW	Total cap.	Sens Cap.	KW	Total cap.	Sens Cap.	KW							
3000	24	19.77	15.34	9.04	22.01	12.15	9.15	24.33	8.79	9.27	19.04	14.97	9.81	21.19	11.79	9.95	23.41	8.44	10.09	18.24	14.59	10.66	20.30	11.40	10.81	22.40	8.06	10.96	17.38	14.18	11.57	19.32	10.99	11.72	21.28	7.64	11.88
	27	19.78	17.95	9.04	22.01	14.79	9.15	24.32	11.46	9.27	19.04	17.59	9.81	21.19	14.43	9.95	23.40	11.10	10.09	18.25	17.21	10.66	20.29	14.04	10.81	22.39	10.72	10.96	17.39	16.80	11.57	19.31	13.63	11.72	21.28	10.31	11.88
	29.5	19.79	19.79	9.04	22.00	16.98	9.15	24.32	13.67	9.27	19.06	19.06	9.81	21.18	16.62	9.95	23.40	13.32	10.09	18.27	18.27	10.66	20.29	16.23	10.81	22.39	12.94	10.96	17.41	17.41	11.57	19.31	15.82	11.72	21.27	12.52	11.88
3900	24	21.00	17.68	9.27	23.25	13.51	9.39	25.53	9.15	9.50	20.18	17.30	10.06	22.34	13.13	10.20	24.51	8.79	10.34	19.29	16.89	10.91	21.34	12.73	11.06	23.39	8.39	11.22	18.32	16.45	11.82	20.25	12.29	11.98	22.15	7.96	12.14
	27	21.02	21.02	9.27	23.25	16.94	9.39	25.53	12.62	9.50	20.19	20.19	10.06	22.33	16.56	10.20	24.50	12.26	10.34	19.31	19.31	10.91	21.33	16.16	11.06	23.38	11.86	11.22	18.34	18.34	11.82	20.24	15.72	11.98	22.15	11.43	12.14
	29.5	21.03	21.03	9.27	23.25	19.79	9.39	25.52	15.50	9.50	20.21	20.21	10.05	22.33	19.41	10.20	24.50	15.14	10.34	19.32	19.32	10.90	21.34	19.01	11.06	23.38	14.74	11.22	18.39	18.39	11.80	20.25	18.57	11.98	22.14	14.31	12.14
5100	24	22.08	20.67	9.69	24.31	15.22	9.82	26.53	9.57	9.93	21.17	20.27	10.49	23.30	14.83	10.64	25.41	9.19	10.78	20.19	19.85	11.34	22.21	14.41	11.50	24.20	8.78	11.66	19.14	19.14	12.25	21.02	13.96	12.42	22.86	8.34	12.59
	27	22.10	22.10	9.69	24.31	19.71	9.82	26.52	14.10	9.93	21.20	21.20	10.48	23.30	19.32	10.64	25.40	13.73	10.78	20.22	20.22	11.33	22.21	18.90	11.50	24.19	13.32	11.67	19.16	19.16	12.23	21.02	18.45	12.42	22.85	12.88	12.59
	29.5	22.19	22.19	9.66	24.31	23.43	9.82	26.51	17.87	9.93	21.36	21.36	10.45	23.31	23.05	10.64	25.40	17.49	10.78	20.53	20.53	11.31	22.22	22.22	11.50	24.19	17.09	11.67	19.65	19.65	12.24	21.03	21.03	12.42	22.85	16.64	12.59
6000	24	22.98	22.98	9.69	24.32	24.32	9.82	26.51	21.62	9.93	22.22	22.22	10.51	23.32	23.32	10.63	25.39	21.24	10.78	21.38	21.38	11.38	22.23	22.23	11.50	24.18	20.84	11.67	20.45	20.45	12.31	21.04	21.04	12.41	22.84	20.39	12.59
	27	22.65	22.65	10.11	24.86	16.47	10.25	27.03	9.86	10.37	21.70	21.70	10.91	23.81	16.08	11.08	25.87	9.47	11.22	20.67	20.67	11.77	22.67	15.65	11.95	24.61	9.06	12.12	19.56	19.56	12.68	21.42	15.19	12.86	23.22	8.62	13.04
	29.5	22.67	22.67	10.11	24.86	21.75	10.25	27.02	15.19	10.37	21.73	21.73	10.90	23.81	21.35	11.08	25.86	14.81	11.23	20.50	20.50	11.69	22.67	20.93	11.95	24.60	14.40	12.12	19.58	19.58	12.61	21.42	20.47	12.86	23.21	13.95	13.05

Notes:

- (1)TEAE - Inlet air temperature on evaporator;
 - (2)BS - Dry Bulb;
 - (3)BU - Humid Bulb;
 - (4)Consumption values refers only to condensers units;
 - (5)Capacity do not include heat effect of motor on evaporator;
 - (6)Capacities are based on 15m max. linear and 10m max. gap between evaporator and condenser unit;
 - (7)Total and sensitive capacity: Mcal/h;
 - (8)Heat generated by fan motor and fan performance table. MBH = Mcal/h x 3,9682.10⁻⁶;
- Cap. Total => 0.96
 Cap. Sens. => 0.98
 kW => 1.01



Cooling Capacities

TRCE (60Hz)

Tab. VI - 17 - Cooling Capacity - Solution Plus 100 - DX100 with TRCE 100 - 1 Circuits

Air Flow (m3/h)	TEAE BS	Inlet Air Temperature on Condenser - BU (°C)																																														
		29,5								35								40,5								46																						
		Evaporator Entering Wet Bulb Temperature - BU (°C)							16							19,5							23							16							19,5							23				
°C	Total cap.	Sens. Cap.	KW	Total cap.	Sens. Cap.	KW	Total cap.	Sens. Cap.	KW	Total cap.	Sens. Cap.	KW	Total cap.	Sens. Cap.	KW	Total cap.	Sens. Cap.	KW	Total cap.	Sens. Cap.	KW	Total cap.	Sens. Cap.	KW	Total cap.	Sens. Cap.	KW	Total cap.	Sens. Cap.	KW																		
4400	24	23,07	19,82	10,67	25,83	15,19	10,83	28,66	10,32	22,24	19,43	11,54	24,92	14,82	11,73	27,64	9,96	11,92	21,32	19,00	12,50	23,90	14,40	12,69	26,51	9,55	12,90	20,32	18,54	13,56	22,78	13,94	13,74	25,24	9,10	13,95												
	27	23,05	21,72	10,68	25,82	19,09	10,84	28,66	14,29	11,00	22,21	21,34	11,55	24,90	18,72	11,73	27,64	13,92	11,92	21,27	20,95	12,51	23,88	18,30	12,70	26,50	13,52	12,90	20,23	20,23	13,57	22,76	17,84	13,75	25,24	13,07	13,96											
	29,5	22,80	22,80	10,67	25,81	22,32	10,84	28,65	17,57	11,00	21,87	21,87	11,54	24,89	21,95	11,73	27,63	17,20	11,92	20,78	20,78	12,47	23,87	21,53	12,70	26,50	16,79	12,91	19,60	19,60	13,50	22,76	20,76	13,75	25,23	16,34	13,96											
	32	22,09	22,09	10,59	25,79	23,85	10,84	28,64	20,82	11,00	21,34	21,34	11,46	24,87	23,12	11,74	27,62	20,45	11,92	20,54	20,54	12,42	23,83	22,73	12,71	26,49	20,04	12,91	19,81	19,81	13,49	22,69	22,33	13,76	25,22	19,59	13,96											
5600	24	24,42	22,68	11,02	27,19	17,03	11,19	30,00	10,85	11,35	23,49	21,85	11,90	26,18	16,63	12,09	28,87	10,46	12,29	22,48	20,83	12,86	25,05	16,19	13,06	27,61	10,03	13,27	21,38	20,01	13,91	23,82	15,71	14,11	26,22	9,57	14,32											
	27	24,29	24,29	11,04	27,18	21,98	11,19	29,99	15,88	11,35	23,31	23,31	11,92	26,16	21,58	12,09	28,86	15,50	12,29	21,41	21,41	12,76	25,04	21,14	13,06	27,61	15,07	13,28	20,41	20,41	13,82	23,81	20,66	14,11	26,22	14,60	14,32											
	29,5	23,33	23,33	10,94	27,16	25,06	11,20	29,98	20,05	11,35	22,49	22,49	11,81	26,15	24,19	12,10	28,85	19,66	12,29	21,57	21,57	12,76	25,02	23,32	13,07	27,60	19,23	13,28	20,62	20,62	13,81	23,78	22,91	14,12	26,21	18,76	14,33											
	32	23,80	23,80	10,95	27,07	27,07	11,21	29,98	24,18	11,36	23,12	23,12	11,84	26,01	26,01	12,12	28,85	23,79	12,29	22,36	22,36	12,82	24,80	24,80	13,09	27,60	23,37	13,28	21,52	21,52	13,88	23,44	23,44	14,13	26,22	22,89	14,33											
6800	24	25,30	24,65	11,42	28,06	18,67	11,60	30,82	11,24	11,77	24,32	23,81	12,31	26,98	18,26	12,50	29,62	10,85	12,70	23,24	23,04	13,27	25,79	17,82	13,47	28,29	10,41	13,70	22,06	22,06	14,32	24,48	17,33	14,52	26,82	9,94	14,74											
	27	24,00	24,00	11,32	28,05	24,67	11,60	30,82	17,32	11,77	23,16	23,16	12,20	26,97	24,26	12,51	29,61	16,92	12,71	22,19	22,19	13,17	25,78	23,81	13,48	28,28	16,49	13,70	21,11	21,11	14,21	24,48	23,33	14,52	26,82	16,01	14,74											
	29,5	24,29	24,29	11,31	28,04	27,41	11,61	30,81	22,35	11,77	23,48	23,48	12,19	26,95	26,94	12,52	29,60	21,96	12,71	22,66	22,66	13,16	25,75	25,75	13,50	28,28	21,52	13,70	21,77	21,77	14,23	24,42	24,42	14,55	26,81	21,05	14,75											
	32	25,22	25,22	11,36	27,86	27,86	11,63	30,80	27,36	11,77	24,47	24,47	12,26	26,68	26,68	12,53	29,60	26,97	12,71	23,63	23,63	13,24	25,38	25,38	13,50	28,28	26,54	13,71	22,71	22,71	14,31	23,90	23,90	14,53	26,82	25,51	14,76											
8000	24	25,97	26,05	11,94	28,72	20,29	12,12	31,44	11,63	12,30	24,94	24,94	12,83	27,58	19,88	13,03	30,17	11,22	13,25	23,81	23,81	13,79	26,33	19,43	14,01	28,79	10,78	14,24	22,57	22,57	14,85	24,97	18,94	15,05	27,27	10,30	15,29											
	27	24,72	24,72	11,83	28,71	27,33	12,12	31,43	18,74	12,30	23,47	23,47	12,63	27,57	26,92	13,03	30,16	18,34	13,25	22,62	22,62	13,60	26,33	26,38	14,01	28,78	17,90	14,24	21,69	21,69	14,67	24,97	25,18	15,06	27,26	17,42	15,29											
	29,5	25,29	25,29	11,81	28,68	28,68	12,14	31,42	24,65	12,31	24,50	24,50	12,71	27,53	27,53	13,06	30,16	24,25	13,25	23,63	23,63	13,69	26,26	26,26	14,04	28,78	23,81	14,25	22,67	22,67	14,76	24,86	24,86	15,09	27,26	23,34	15,30											
	32	26,33	26,33	11,88	28,37	28,37	12,16	31,42	30,54	12,31	25,52	25,52	12,79	27,13	27,13	13,06	30,15	30,14	13,26	24,62	24,62	13,78	25,75	25,75	14,01	28,78	28,86	14,26	23,63	23,63	14,85	24,24	24,24	15,01	27,25	27,77	15,31											

Tab. VI - 18 - Cooling Capacity - Solution Plus 100 - DX100 with TRCE 100 - 2 Circuits

Air Flow (m3/h)	TEAE BS	Inlet Air Temperature on Condenser - BU (°C)																																														
		29,5								35								40,5								46																						
		Evaporator Entering Wet Bulb Temperature - BU (°C)							16							19,5							23							16							19,5							23				
°C	Total cap.	Sens. Cap.	KW	Total cap.	Sens. Cap.	KW	Total cap.	Sens. Cap.	KW	Total cap.	Sens. Cap.	KW	Total cap.	Sens. Cap.	KW	Total cap.	Sens. Cap.	KW	Total cap.	Sens. Cap.	KW	Total cap.	Sens. Cap.	KW	Total cap.	Sens. Cap.	KW	Total cap.	Sens. Cap.	KW	Total cap.	Sens. Cap.	KW															
4400	24	26,79	21,41	12,55	29,60	16,65	12,69	32,45	11,66	12,84	25,74	20,91	13,51	28,45	16,17	13,67	31,17	11,19	13,82	24,54	20,34	14,53	27,17	15,63	14,70	29,77	10,68	14,85	23,17	19,70	15,59	25,71	15,03	15,76	28,19	10,11	15,91											
	27	26,80	25,25	12,55	29,59	20,52	12,70	32,44	15,58	12,84	25,75	24,75	13,51	28,45	20,04	13,67	31,17	15,10	13,83	24,56	24,18	14,53	27,16	15,50	14,70	29,76	14,59	14,85	23,20	23,20	15,59	25,71	18,90	15,76	28,18	14,02	15,91											
	29,5	26,82	26,82	12,55	29,59	23,74	12,70	32,44	18,83	12,84	25,77	25,77	13,51	28,45	23,25	13,67	31,16	18,35	13,83	24,57	24,57	14,53	27,16	22,71	14,70	29,76	17,84	14,85	23,21	23,21	15,58	25,71	22,11	15,76	28,17	17,27	15,91											
	32	26,83	26,83	12,53	29,59	26,94	12,69	32,43	22,06	12,84	25,81	25,81	13,49	28,45	26,46	13,67	31,15	21,59	13,83	24,72	24,72	14,51	27,17	25,92	14,70	29,75	21,07	14,85	23,64	23,64	15,59	25,72	25,32	15,76	28,17	20,50	15,91											
5600	24	28,13	24,45	12,88	30,92	18,39	13,03	33,70	12,09	13,18	26,99	23,93	13,85	29,67	17,89	14,01	32,30	11,60	14,16	25,70	23,35	14,87	28,28	17,34	15,03	30,79	11,08	15,19	24,24	22,70	15,93	26,72	16,73	16,10	29,09	10,49	16,24											
	27	28,15	28,15	12,88	30,91	23,32	13,03	33,69	17,07	13,18	27,01	27,01	13,85	29,66	22,82	14,01	32,29	16,58	14,16	25,73	25,73	14,86	28,28	22,27	15,03	30,78	16,06	15,19	24,27	24,27	15,92	26,72	21,65	16,10	29,08	15,48	16,24											
	29,5	28,17	28,17	12,87	30,91	27,41	13,03	33,68	21,20	13,18	27,05	27,05	13,83	29,67	26,91	14,01	32,29	20,72	14,16	25,80	25,80	14,84	28,28	26,36	15,03	30,77	20,19	15,19	24,46	24,46	15,89	26,73	25,75	16,09	29,07	19,61	16,24											
	32	28,66	28,66	12,86	30,92	30,92	13,03	33,68	25,32	13,18	27,73	27,73	13,84	29,68	29,68	14,01	32,28	24,83	14,16	26,67	26,67	14,88	28,30	28,30	15,03	30,77	24,31	15,19	25,47	25,47	15,96	26,74	26,74	16,09	29,07	23,73	16,24											
6800	24	29,07	27,40	13,30	31,82	20,07	13,46	34,53	12,47	13,62	27,86	26,87	14,27	30,49	19,55	14,44	33,05	11,98	14,60	26,51	26,28	15,29	29,04	19,00	15,47	31,46	11,45	15,63	24,98	24,98	16,35	27,40	18,38	16,53	29,69	10,86	16,68											
	27	29,09	29,09	13,30	31,81	26,05	13,46	34,52	18,52	13,62	27,89	27,89	14,27	30,49	25,54	14,44	33,04	18,03	14,61	26,53	26,53	15,28	29,03	24,98	15,47	31,45	17,49	15,63	25,02	25,02	16,33	27,40	24,36	16,53	29,68	16,91	16,68											
	29,5	29,23	29,23	13,25	31,82	31,01	13,46	34,52	23,54	13,62	28,14	28,14	14,22	30,49	30,49	14,44	33,04	23,05	14,61	27,02	27,02	15,26	29,04	29,04	15,47	31,44	22,51	15,63	25																			

Cooling Capacities

TRCE (60Hz)

Tab. VI - 19 - Cooling Capacity - Solution Plus 125: DX125 with TRCE050 1C + TRCE075 1C

Air Flow (m³/h)	TEAE BS	Temperatura de Entrada de Ar no Condensador - BU (°C)																																																														
		29,5									35									40,5									46																																			
		Temperatura Bulbo Umido Entrada do Evaporador - BU (°C)																																																														
		16							19,5							23							16							19,5							23							16							19,5							23						
		16							19,5							23							16							19,5							23							16							19,5							23						
		°C	Total cap.	Sens Cap.	KW	Total cap.	Sens Cap.	KW	Total cap.	Sens Cap.	KW	Total cap.	Sens Cap.	KW	Total cap.	Sens Cap.	KW	Total cap.	Sens Cap.	KW	Total cap.	Sens Cap.	KW	Total cap.	Sens Cap.	KW	Total cap.	Sens Cap.	KW	Total cap.	Sens Cap.	KW	Total cap.	Sens Cap.	KW	Total cap.	Sens Cap.	KW																										
5500	24	33,67	26,86	15,15	37,39	20,99	15,32	41,21	14,83	15,49	32,37	26,24	16,40	35,95	20,37	16,61	39,58	14,22	16,80	30,94	25,56	17,75	26,00	34,35	19,70	17,97	37,80	13,56	18,19	29,35	24,81	19,19	38,00	32,59	18,97	19,42	39,00	35,81	12,85	19,64																								
	27	33,69	31,66	15,14	37,38	25,83	15,32	41,20	19,72	15,49	32,40	31,04	16,40	35,94	25,21	16,61	39,57	19,11	16,80	30,97	30,36	17,75	29,00	34,34	24,54	17,97	37,79	18,46	18,19	29,39	29,26	19,19	41,00	32,58	23,81	19,42	42,00	35,80	17,74	19,64																								
	29,5	33,72	33,72	15,14	37,38	29,85	15,32	41,19	23,78	15,49	32,43	32,43	16,40	35,94	29,23	16,61	39,56	23,17	16,80	30,99	30,99	17,74	32,00	34,35	28,56	17,97	37,78	22,52	18,19	29,40	29,40	19,17	44,00	32,59	27,83	19,42	45,00	35,80	21,80	19,64																								
	32	33,72	33,72	15,11	37,39	33,85	15,32	41,18	27,82	15,49	32,53	32,53	16,37	35,95	33,24	16,61	39,55	27,22	16,80	31,23	31,23	17,72	35,00	34,36	32,57	17,97	37,77	26,56	18,19	29,89	29,89	19,18	47,00	32,61	31,84	19,42	48,00	35,79	25,84	19,64																								
7000	24	35,45	30,70	15,56	39,17	23,20	15,74	42,92	15,40	15,91	34,02	30,04	16,83	37,57	22,56	17,04	41,13	14,77	17,24	32,45	29,33	18,18	74,00	35,83	21,87	18,41	39,19	14,09	18,63	30,72	28,56	19,62	86,00	33,90	21,11	19,85	87,00	37,04	13,35	20,08																								
	27	35,49	35,49	15,56	39,16	29,36	15,74	42,91	21,62	15,91	34,06	34,06	16,83	37,57	28,72	17,04	41,12	20,99	17,24	32,49	32,49	18,18	77,00	35,83	28,03	18,41	39,18	20,32	18,63	30,76	30,76	19,62	89,00	33,91	27,27	19,85	90,00	37,03	19,58	20,08																								
	29,5	35,51	35,51	15,54	39,17	34,47	15,74	42,90	26,79	15,91	34,07	34,07	16,78	37,58	33,83	17,04	41,11	26,16	17,24	32,63	32,63	18,14	80,00	35,84	33,14	18,41	39,17	25,49	18,63	31,05	31,05	19,57	92,00	33,92	32,39	19,85	93,00	37,02	24,75	20,08																								
	32	36,14	36,14	15,52	39,19	39,07	15,74	42,89	31,94	15,91	34,98	34,98	16,81	37,60	37,60	17,04	41,10	31,31	17,24	33,69	33,69	18,18	83,00	35,86	35,86	18,41	39,17	30,63	18,63	32,24	32,24	19,65	95,00	33,94	33,94	19,85	96,00	37,02	29,90	20,08																								
8500	24	36,71	34,42	16,09	40,39	25,33	16,28	44,08	15,91	16,45	35,18	33,74	17,36	38,69	24,67	17,58	42,17	15,26	17,79	33,51	32,92	18,72	122,00	36,84	23,96	18,96	40,13	14,58	19,19	31,67	31,67	20,16	134,00	34,80	23,19	20,40	135,00	37,86	13,83	20,64																								
	27	36,75	36,75	16,08	40,39	32,81	16,28	44,06	23,47	16,45	35,22	35,22	17,36	38,69	32,15	17,58	42,16	22,83	17,79	33,55	33,55	18,70	125,00	36,84	31,44	18,96	40,11	22,14	19,19	31,71	31,71	20,10	137,00	34,81	30,67	20,40	138,00	37,85	21,39	20,64																								
	29,5	36,99	36,99	16,02	40,40	39,01	16,28	44,06	29,74	16,45	35,60	35,60	17,29	38,70	38,12	17,58	42,15	29,10	17,79	34,15	34,15	18,65	128,00	36,86	36,86	18,96	40,11	28,42	19,19	32,62	32,62	20,12	140,00	34,83	34,83	20,40	141,00	37,84	27,67	20,64																								
	32	38,28	38,28	16,06	40,42	40,42	16,28	44,05	35,99	16,45	36,99	36,99	17,36	38,72	38,72	17,58	42,15	35,35	17,79	35,56	35,56	18,75	131,00	36,87	36,87	18,95	40,10	34,67	19,19	33,96	33,96	20,21	143,00	34,84	34,84	20,38	144,00	37,83	33,91	20,64																								
10000	24	37,35	37,35	16,69	41,29	27,40	16,97	44,92	16,39	17,16	36,04	36,04	18,04	39,51	26,73	18,28	42,94	15,74	18,50	34,29	34,29	19,40	170,00	37,58	26,01	19,66	40,01	15,94	19,91	32,38	32,38	20,84	182,00	35,46	25,23	21,11	183,00	38,46	14,29	21,36																								
	27	37,69	37,69	16,74	41,52	36,29	17,01	44,91	25,29	17,16	36,10	36,10	18,01	39,51	35,53	18,28	42,92	24,64	18,51	34,09	34,09	19,25	173,00	37,59	34,81	19,66	40,79	23,94	19,91	32,50	32,50	20,71	185,00	35,47	34,03	21,10	186,00	38,45	23,19	21,36																								
	29,5	38,40	38,40	16,67	41,31	41,31	16,97	44,90	32,67	17,16	37,05	37,05	17,97	39,53	39,53	18,28	42,91	32,02	18,51	35,56	35,56	19,35	176,00	37,60	37,60	19,66	40,78	31,32	19,91	33,90	33,90	20,81	188,00	35,48	35,48	21,10	189,00	38,43	30,57	21,36																								
	32	39,94	39,94	16,74	41,32	41,32	16,96	44,89	40,02	17,16	38,54	38,54	18,06	39,54	39,54	18,26	42,90	39,37	18,51	37,00	37,00	19,45	179,00	37,63	37,63	19,61	40,77	38,67	19,91	35,27	35,27	20,92	191,00	35,62	35,62	21,02	192,00	38,42	37,64	21,35																								

Tab. VI - 20 - Cooling Capacity - Solution Plus 150 - DX150 with TRCE 150 - 1 Circuit

Air Flow (m³/h)	TEAE BS	Inlet Air Temperature on Condenser - BU (°C)																																																														
		29,5									35									40,5									46																																			
		Evaporator Entering Wet Bulb Temperature - BU (°C)																																																														
		16							19,5							23							16							19,5							23							16							19,5							23						
		16							19,5							23							16							19,5							23							16							19,5							23						
		°C	Total cap.	Sens Cap.	KW	Total cap.	Sens Cap.	KW	Total cap.	Sens Cap.	KW	Total cap.	Sens Cap.	KW	Total cap.	Sens Cap.	KW	Total cap.	Sens Cap.	KW	Total cap.	Sens Cap.	KW	Total cap.	Sens Cap.	KW	Total cap.	Sens Cap.	KW	Total cap.	Sens Cap.	KW	Total cap.	Sens Cap.	KW	Total cap.	Sens Cap.	KW																										
6000	24	41,67	31,75	17,31	45,86	25,13	17,53	50,12	18,17	17,76	40,03	30,92	18,88	44,07	24,33	19,14	48,15	17,40	19,40	38,28	30,06	20,53	42,14	23,49	20,83	46,04	16,59	21,11	36,42	29,15	22,25	40,05	22,59	22,58	43,71	15,72	22,89																											
	27	41,77	36,88	17,30	45,87	30,41	17,53	50,11	23,50	17,76	40,15	36,04	18,87	44,07	29,61	19,13	48,14	22,74	19,40	38,43	35,16	20,53	42,15	28,77	20,82	46,02	21,93	21,11	36,61	34,23	22,25	40,06	27,87	22,57	43,69	21,06	22,89																											
	29,5	42,07	41,24	17,30	45,88	34,79	17,52	50,10	27,93	17,76	40,51	40,43	18,87	44,08	34,00	19,13	48,13	27,17	19,39	38,86	38,86	20,54	42,17	33,16	20,82	46,01	26,36	21,11	37,16	37,16	22,28	40,10	32,26	22,57	43,69	25,48	22,89																											
	32	43,09	43,09	17,33	45,96	39,19	17,52	50,09	32,34	17,76	41,72	18,93	44,19	38,40	19,12	48,13	31,58	19,39	40,26	40,26	20,63	42,30	37,57	20,81	46,01	30,77	21,11	38,66	38,65	22,40	40,25	36,47	22,57	43,69	29,89	22,88																												
7800	24	43,73	36,17	17,80	47,83	27,58	18,05	51,97	18,65	18,29	41,95	35,33	19,39	45,89	26,78	19,67	49,85	17,89	19,94	40,06	34,46	21,05	43,80	25,93	21,36	47,57	17,07	21,66	38,04	33,29	22,78	41,54	25,02	23,12	45,07	16,20	23,44																											
	27	44,08	42,76	17,79	47,84	34,44	18,05	51,95	25,59	18,29	42,35	41,91	19,38	45,90	33,64	19,66	49,83	24,82	19,94	40,53	40,53	21,05	43,81	32,79	21,36	47,55	24,01	21,66	38,60	38,60	22,79	41,55	31,88	23,11	45,05	23,13	23,44																											
	29,5	45,08	45,08	17,81	47,91	40,16	18,03	51,94	31,34	18,29	43,55	43,55	19,42	45,99	39,37	19,65	49,82	30,57	19,93	41,91	41,91	21,13	43,93	38,53	21,34	47,54	29,76	21,65	40,11	40,11	22,90	41,70	37,31	23,10	45,04	28,89	23,43																											
	32	46,87	46,87	17,91	48,19	45,58	18,03	51,94	37,07	18,29	45,30	45,30	19,53	46,30	44,76	19,64	49,82	36,30	19,93	43,61	43,60	21,25	44,30	43,89	21,34	47,54	35,50	21,64	41,73	41,73	23,04	42,12	42,12	23,11	45,05	34,62	23,42																											
10200	24	45,51	41,55	18,70	49,41	30,76	18,99	53,43	19,27	19,26	43,63	40,67	20,29	47,34	29,96	20,62	51,18	18,51	20,91	41,63	39,74	21,96	45,12	29,10	22,32	48,77	17,71	22,64	39,50	38,76	23,70	42,72	28,18	24,09	46,14	16,83	24,42																											
	27	46,45	46,45	18,67	49,43	39,74	18,97	53,41	28,35	19,26	44,76	44,76	20,29	47,37	38,94	20,60	51,16	27,58	20,91	42,97	42,97	21,99	45,17	38,09	22,29	48,75	26,78	22,64	41,00	41,00	23,77	42,79	36,79	24,05	46,12	25,90	24,42																											
	29,5	48,34	48,34	18,77	49,69	46,78	18,95	53,39	35,87	19,26	46,62	46,62	20,41	47,67	45,94	20,57	51,14	35,10	20,91	44,77	44,77	22,13	45,52	45,05	22,27	48,73	34,29	22,64	42,72	42,72	23,92	43,18	43,18	24,03	46,09	33,42	24,41																											
	32	50,23	50,23	18,89	50,41	50,41	18,94	53,41	43,37	19,24	48,45	48,45	20,54	48,51	48,51	20,57	51,18	42,61	20,88	46,53	46,53	22,27	46,57	46,57	22,30	48,79	41,81	22,61	44,39																																			



Cooling Capacities

TRCE (60Hz)

Tab. VI - 21 - Cooling Capacity - Solution Plus 150 - DX150 with TRCE 150 - 2 Circuits

Air Flow (m³/h)	TEAE BS	Inlet Air Temperature on Condenser - BU (°C)																																			
		29.5									35									40.5									46								
		Evaporator Entering Wet Bulb Temperature - BU (°C)																																			
		16			19.5			23			16			19.5			23			16			19.5			23			16			19.5			23		
°C	Total cap.	Sens. Cap.	KW	Total cap.	Sens. Cap.	KW	Total cap.	Sens. Cap.	KW	Total cap.	Sens. Cap.	KW	Total cap.	Sens. Cap.	KW	Total cap.	Sens. Cap.	KW	Total cap.	Sens. Cap.	KW	Total cap.	Sens. Cap.	KW	Total cap.	Sens. Cap.	KW	Total cap.	Sens. Cap.	KW	Total cap.	Sens. Cap.	KW	Total cap.	Sens. Cap.	KW	
6000	24	40.07	30.93	17.81	44.54	24.52	18.07	49.15	17.77	18.33	38.58	30.20	19.39	42.89	23.80	19.69	47.31	17.06	19.99	36.97	29.41	21.10	41.09	23.02	21.43	45.30	16.30	21.76	35.24	28.58	22.96	39.14	22.19	23.29	43.08	15.47	23.64
	27	40.08	36.17	17.81	44.53	29.80	18.07	49.13	23.10	18.33	38.59	35.43	19.39	42.88	29.08	19.69	47.29	22.40	19.99	36.98	34.65	21.10	41.08	28.30	21.43	45.29	21.64	21.76	35.26	33.81	22.96	39.13	27.46	23.29	43.06	20.81	23.64
	29.5	40.10	40.10	17.81	44.52	34.18	18.07	49.12	27.53	18.33	38.61	38.61	19.39	42.87	33.46	19.69	47.28	26.83	19.99	37.01	37.01	21.10	41.07	32.68	21.43	45.28	26.06	21.76	35.29	35.29	22.96	39.12	31.85	23.29	43.06	25.23	23.64
7800	24	40.07	40.07	17.80	44.52	38.55	18.07	49.11	31.95	18.33	38.58	38.58	19.37	42.87	37.82	19.69	47.27	31.24	19.99	36.99	36.99	21.07	41.08	37.05	21.42	45.27	30.48	21.76	35.34	35.34	22.93	39.13	36.22	23.29	43.05	29.65	23.64
	27	42.57	42.41	18.36	47.01	34.09	18.63	51.54	25.42	18.88	40.91	40.91	19.95	45.17	33.33	20.26	49.50	24.69	20.57	39.11	39.11	21.67	43.18	32.53	22.01	47.28	23.90	22.35	37.18	37.18	23.52	41.00	31.65	23.87	44.82	23.04	24.23
	29.5	42.60	42.60	18.35	47.01	39.79	18.63	51.53	31.18	18.88	40.93	40.93	19.94	45.17	39.03	20.26	49.49	30.44	20.57	39.14	39.14	21.65	43.18	38.22	22.01	47.27	29.66	22.35	37.18	37.18	23.48	41.01	37.35	23.87	44.81	28.80	24.23
10200	24	42.88	42.88	18.32	47.02	45.46	18.63	51.52	36.92	18.88	41.52	41.52	19.94	45.19	44.71	20.26	49.48	36.18	20.57	40.06	40.06	21.69	43.20	43.20	22.01	47.26	35.39	22.35	38.47	38.47	23.57	41.03	41.03	23.87	44.80	34.53	24.23
	27	44.73	44.73	19.31	49.12	39.62	19.60	53.52	28.37	19.86	42.91	42.91	20.92	47.11	38.84	21.25	51.30	27.62	21.57	40.95	40.95	22.64	44.95	38.00	23.01	48.90	26.81	23.37	38.84	38.84	24.47	42.58	37.10	24.87	46.24	25.93	25.25
	29.5	44.91	44.91	19.25	49.13	47.06	19.60	53.51	35.90	19.86	43.24	43.24	20.84	47.12	46.29	21.25	51.29	35.15	21.58	41.58	41.58	22.60	44.96	44.96	23.01	48.88	34.34	23.37	39.80	39.80	24.49	42.59	42.59	24.87	46.23	33.46	25.25
12000	24	46.48	46.48	19.33	49.14	49.14	19.60	53.50	43.40	19.86	44.95	44.95	20.98	47.14	47.14	21.25	51.28	42.65	21.58	43.27	43.27	22.75	44.97	44.97	23.01	48.87	41.84	23.37	41.43	41.43	24.64	42.60	42.60	24.86	46.22	40.96	25.25
	27	45.83	45.83	20.27	50.22	33.13	20.58	54.55	19.87	20.86	43.92	43.92	21.89	48.12	32.34	22.25	52.23	19.11	22.59	41.86	41.86	23.62	45.86	31.49	24.02	49.74	18.30	24.39	39.64	39.64	25.47	43.38	30.58	25.88	46.98	17.41	26.27
	29.5	46.64	46.64	20.19	50.22	50.22	20.58	54.52	39.41	20.86	45.04	45.04	21.84	48.13	48.13	22.25	52.20	38.65	22.59	43.29	43.29	23.61	45.86	45.86	24.01	49.71	37.83	24.40	41.37	41.37	25.50	43.39	43.39	25.87	46.95	36.94	26.28
32	48.49	48.49	20.31	50.23	50.23	20.58	54.50	48.23	20.86	46.84	46.84	21.98	48.13	48.13	22.24	52.19	47.47	22.59	45.03	45.03	23.77	45.88	45.88	23.98	49.69	46.65	24.40	43.03	43.03	25.66	43.46	43.46	25.81	46.93	45.76	26.27	

Tab. VI - 22 - Cooling Capacity - Solution Plus 200 - DX200 with TRCE 100 + TRCE 100 - 2 Circuits

Air Flow (m³/h)	TEAE BS	Inlet Air Temperature on Condenser - BU (°C)																																			
		29.5									35									40.5									46								
		Evaporator Entering Wet Bulb Temperature - BU (°C)																																			
		16			19.5			23			16			19.5			23			16			19.5			23			16			19.5			23		
°C	Total cap.	Sens. Cap.	KW	Total cap.	Sens. Cap.	KW	Total cap.	Sens. Cap.	KW	Total cap.	Sens. Cap.	KW	Total cap.	Sens. Cap.	KW	Total cap.	Sens. Cap.	KW	Total cap.	Sens. Cap.	KW	Total cap.	Sens. Cap.	KW	Total cap.	Sens. Cap.	KW	Total cap.	Sens. Cap.	KW	Total cap.	Sens. Cap.	KW	Total cap.	Sens. Cap.	KW	
9000	24	53.18	43.01	20.82	58.55	33.21	21.09	63.73	22.87	21.34	51.13	42.04	22.73	56.39	32.30	23.03	61.45	22.03	23.34	48.91	41.00	24.82	54.04	31.33	25.14	58.97	21.14	25.47	46.56	39.91	27.09	51.46	30.27	27.39	56.19	20.14	27.71
	27	53.20	50.86	20.82	58.53	41.13	21.09	63.71	30.87	21.34	51.15	49.89	22.73	56.37	40.22	23.03	61.43	30.04	23.34	48.95	48.85	24.81	54.03	39.24	25.14	58.95	29.14	25.47	46.60	46.60	27.07	51.46	38.19	27.38	56.17	28.15	27.71
	29.5	53.26	53.26	20.79	58.53	47.70	21.09	63.69	37.52	21.34	51.27	51.27	22.69	56.37	46.79	23.03	61.41	36.68	23.34	49.16	49.16	24.77	54.03	45.82	25.13	58.94	35.78	25.47	47.00	47.00	27.03	51.46	44.76	27.38	56.16	34.79	27.71
11300	24	54.32	54.32	20.79	58.53	54.24	21.08	63.68	44.13	21.34	52.67	52.67	22.73	56.38	53.34	23.03	61.40	43.30	23.34	50.88	50.88	24.84	54.04	52.37	25.13	58.92	42.40	25.47	48.93	48.93	27.13	51.47	51.31	27.37	56.15	41.41	27.71
	27	55.62	55.62	21.55	60.80	54.66	21.81	65.75	42.00	22.06	54.46	54.46	23.39	58.52	53.75	23.77	63.34	41.17	24.09	52.51	52.51	25.50	56.04	52.77	25.87	60.73	40.27	26.23	50.37	50.37	27.77	53.30	51.69	28.11	57.79	39.27	28.47
	29.5	56.27	56.27	21.44	60.80	54.66	21.81	65.75	42.00	22.06	54.46	54.46	23.39	58.52	53.75	23.77	63.34	41.17	24.09	52.51	52.51	25.50	56.04	52.77	25.87	60.73	40.27	26.23	50.37	50.37	27.77	53.30	51.69	28.11	57.79	39.27	28.47
13600	24	57.28	54.42	22.44	62.35	39.63	22.74	67.19	24.31	23.00	55.00	53.42	24.37	59.97	38.72	24.73	64.65	23.46	25.06	52.54	52.35	26.46	57.39	37.73	26.84	61.95	22.57	27.21	49.87	49.87	28.71	54.53	36.65	29.08	58.92	21.57	29.45
	27	57.45	57.45	22.36	62.32	51.58	22.74	67.16	36.41	23.00	55.28	55.28	24.27	59.95	50.67	24.72	64.63	35.56	25.06	52.99	52.99	26.34	57.37	49.69	26.83	61.93	34.66	27.21	50.65	50.65	28.57	54.52	48.61	29.07	58.90	33.67	29.45
	29.5	59.14	59.14	22.37	62.30	61.50	22.74	67.14	46.45	23.00	57.21	57.21	24.34	59.93	59.85	24.72	64.60	45.59	25.06	55.12	55.12	26.46	57.36	57.36	26.82	61.89	44.70	27.21	52.80	52.80	28.72	54.51	54.51	29.04	58.86	43.70	29.45
17000	24	61.34	61.34	22.49	62.38	62.38	22.67	67.12	56.44	23.00	59.39	59.39	24.48	60.08	60.08	24.64	64.55	55.58	25.06	57.26	57.26	26.61	57.63	57.63	26.72	61.84	54.68	27.20	54.88	54.88	28.87	54.97	54.97	28.92	58.80	53.68	29.44
	27	59.81	59.81	24.06	63.80	59.13	24.62	68.64	40.46	24.94	57.78	57.77	26.03	61.34	58.22	26.63	65.89	39.57	27.02	55.57	55.57	28.15	58.67	57.24	28.74	63.09	38.68	29.18	53.13	53.13	30.41	55.70	55.70	30.97	59.96	37.68	31.43
	29.5	62.11	62.11	24.20	63.76	63.76	24.58	68.60	53.00	24.94	60.05	60.05	26.20	61.33	61.33	26.55	65.82	52.10	27.01	57.81	57.81	28.33	58.71	58.71	28.63	63.02	51.20	29.18	55.30	55.30	30.59	55.82	55.82	30.82	59.87	50.20	31.42
32	64.33	64.33	24.32	64.37	64.37	24.36	68.55	65.49	24.94	62.23	62.23	26.36	62.26	62.26	26.42	65.72	64.57	27.01	59.94	59.94	28.51	59.97	59.97	28.57	62.91	62.91	29.17	57.37	57.37	30.77	57.39	57.39	30.83	59.77	59.77	31.41	

Notes:
 (1) TEAE - Inlet air temperature on evaporator;
 (2) BS - Dry Bulb;
 (3) BU - Humid Bulb;
 (4) Cunsumption values refers only to condensers units;
 (5) Capacity do not include heat effect of motor on evaporator;
 (6) Capacities are based on 15m max. linear and 10m max. gap between evaporator and condenser unit;
 (7) Total and sensitive capacity: Mkkal/h;
 (8) Heat generated by fan motor and fan performance table. MBH = Mkkal/h x 3,9682.10⁻⁶;
 Cap. Total => 0.96
 Cap. Sens. => 0.98
 kW => 1.01

Cooling Capacities

TRCE (60Hz)

Tab. VI - 23 - Cooling Capacity - Solution Plus 250 - DX250 with TRCE 150 + TRCE 100 - 2 Circuits

Air Flow (m3/h)	TEAE BS	Inlet Air Temperature on Condenser - BU (°C)																																			
		29,5									35									40,5									46								
		16						19,5			23			16			19,5			23			16			19,5			23								
		°C	Total cap.	Sens. Cap.	KW	Total cap.	Sens. Cap.	KW	Total cap.	Sens. Cap.	KW	Total cap.	Sens. Cap.	KW	Total cap.	Sens. Cap.	KW	Total cap.	Sens. Cap.	KW	Total cap.	Sens. Cap.	KW	Total cap.	Sens. Cap.	KW	Total cap.	Sens. Cap.	KW								
12000	24	68,40	56,30	28,08	75,26	43,26	28,42	82,05	29,59	28,76	65,82	55,08	30,64	72,53	42,11	31,04	79,12	28,51	31,44	63,04	53,49	33,38	69,54	40,87	33,81	75,93	27,35	34,26	60,07	52,08	36,26	66,28	39,53	36,73	72,37	26,08	37,19
	27	68,36	64,41	28,05	75,24	53,81	28,42	82,03	40,26	28,76	65,78	62,45	30,60	72,51	52,66	31,04	79,10	39,19	31,44	63,00	60,30	33,32	69,53	51,42	33,81	75,90	38,02	34,26	60,04	57,83	36,17	66,27	50,09	36,72	72,34	36,75	37,19
	29,5	68,76	68,13	28,02	75,23	62,56	28,41	82,01	49,11	28,76	66,43	66,19	30,59	72,51	61,08	31,03	79,07	48,04	31,44	63,91	63,91	33,33	69,54	59,82	33,80	75,88	46,88	34,25	61,20	61,20	36,21	66,29	58,45	36,71	72,32	45,60	37,19
	32	70,11	70,11	28,05	75,18	69,38	28,40	81,97	57,93	28,76	67,88	67,88	30,64	72,44	67,44	31,00	79,04	56,85	31,44	65,57	65,57	33,38	69,47	65,30	33,76	75,84	55,69	34,25	63,14	63,14	36,31	66,22	62,88	36,65	72,29	54,41	37,18
15000	24	71,48	63,44	29,00	78,23	47,56	29,37	84,84	30,62	29,73	68,72	62,16	31,58	75,31	46,39	32,01	81,71	29,53	32,43	65,73	60,34	34,32	72,12	45,13	34,79	78,31	28,36	35,26	62,51	58,03	37,20	68,62	43,76	37,71	74,52	27,07	38,20
	27	71,46	69,51	28,89	78,20	60,74	29,36	84,81	43,96	29,73	68,92	67,78	31,48	75,28	59,57	32,00	81,68	42,87	32,43	66,17	65,52	34,23	72,10	58,31	34,78	78,28	41,70	35,26	63,20	63,20	37,13	68,61	56,50	37,70	74,49	40,40	38,20
	29,5	72,74	72,74	28,93	78,18	70,76	29,35	84,78	55,03	29,73	70,26	70,26	31,53	75,25	68,78	31,98	81,63	53,93	32,42	67,58	67,58	34,27	72,06	66,61	34,75	78,23	52,75	35,25	64,75	64,75	37,17	68,57	64,20	37,65	74,43	51,46	38,18
	32	74,99	74,99	28,98	78,07	74,97	29,26	84,74	66,04	29,72	72,69	72,69	31,62	75,26	72,74	31,88	81,56	64,93	32,41	70,18	70,18	34,41	72,33	70,88	34,67	78,16	63,24	35,24	67,40	67,40	37,35	69,10	68,33	37,60	74,37	61,89	38,17
17000	24	72,97	67,27	29,74	79,66	50,34	30,14	86,20	31,27	30,51	70,11	65,24	32,32	76,65	49,16	32,78	82,95	30,17	33,22	67,01	63,03	35,05	73,36	47,89	35,58	79,45	28,99	36,06	63,69	60,62	37,93	69,75	46,51	38,50	75,55	27,69	39,00
	27	73,37	73,05	29,63	79,62	64,80	30,13	86,17	46,39	30,52	70,74	70,74	32,23	76,60	63,59	32,77	82,91	45,28	33,23	67,87	67,87	34,99	73,33	62,28	35,56	79,41	44,10	36,06	64,78	64,78	37,88	69,72	60,85	38,48	75,50	42,80	39,00
	29,5	74,82	74,82	29,65	79,53	73,93	30,09	86,12	58,92	30,51	72,32	72,32	32,25	76,53	71,87	32,72	82,83	57,80	33,22	69,76	69,76	35,01	73,27	69,60	35,49	79,33	56,62	36,05	66,90	66,90	37,95	69,69	67,01	38,37	75,42	55,32	38,98
	32	77,54	77,54	29,73	79,83	78,78	29,99	86,06	71,40	30,51	75,11	75,11	32,39	77,03	76,48	32,66	82,74	69,63	33,21	72,46	72,46	35,21	73,98	73,98	35,46	79,24	68,40	36,04	69,52	69,52	38,15	70,60	70,60	38,38	75,33	66,95	38,97
21000	24	75,11	72,33	31,56	81,74	55,78	32,09	88,26	32,53	32,53	72,14	70,16	34,13	78,58	54,59	34,75	84,76	31,38	35,25	68,94	67,73	36,85	75,15	53,31	37,55	81,11	30,20	38,10	65,55	64,39	39,70	71,37	51,91	40,48	77,06	28,89	41,05
	27	76,22	76,22	31,48	81,65	73,15	32,08	88,20	51,20	32,54	73,47	73,47	34,08	78,50	71,19	34,74	84,67	50,04	35,25	70,50	70,50	36,84	75,08	69,05	37,53	81,02	48,86	38,10	67,30	67,30	39,71	71,29	66,54	40,42	76,96	47,55	41,04
	29,5	78,51	78,51	31,46	81,56	79,48	31,91	88,12	66,68	32,53	75,94	75,94	34,13	78,46	76,99	34,51	84,54	65,50	35,24	73,15	73,15	36,94	75,26	74,25	37,34	80,89	63,58	38,08	70,04	70,04	39,89	71,70	71,70	40,26	76,82	62,20	41,02
	32	81,40	81,40	31,63	82,63	82,63	31,91	88,03	79,34	32,52	78,74	78,74	34,32	79,60	79,60	34,58	84,41	77,09	35,22	75,87	75,87	37,16	76,41	76,41	37,38	80,71	74,78	38,03	72,66	72,66	40,12	72,90	72,90	40,28	76,64	72,19	40,93

Tab. VI - 24 - Cooling Capacity - Solution Plus 300 - DX300 with TRCE 150 + TRCE 150 - 2 Circuits

Air Flow (m3/h)	TEAE BS	Inlet Air Temperature on Condenser - BU (°C)																																			
		29,5									35									40,5									46								
		16			19,5			23			16			19,5			23			16			19,5			23			16			19,5			23		
		°C	Total cap.	Sens. Cap.	KW	Total cap.	Sens. Cap.	KW	Total cap.	Sens. Cap.	KW	Total cap.	Sens. Cap.	KW	Total cap.	Sens. Cap.	KW	Total cap.	Sens. Cap.	KW	Total cap.	Sens. Cap.	KW	Total cap.	Sens. Cap.	KW	Total cap.	Sens. Cap.	KW	Total cap.	Sens. Cap.	KW					
15000	24	86,12	70,51	35,72	94,61	54,12	36,12	102,96	36,95	36,57	82,87	68,97	38,98	91,14	52,68	39,43	99,24	35,60	39,91	79,36	67,34	42,43	87,41	51,14	42,93	95,23	34,16	43,44	75,66	65,63	46,01	83,31	49,47	46,57	90,77	32,58	47,11
	27	86,17	83,60	35,70	94,59	67,31	36,12	102,93	50,29	36,57	82,93	81,32	38,97	91,13	65,87	39,42	99,21	48,94	39,92	79,45	79,45	42,41	87,40	64,33	42,93	95,21	47,50	43,45	75,75	75,75	45,98	83,31	62,67	46,56	90,75	45,92	47,11
	29,5	86,35	86,35	35,66	94,59	78,26	36,11	102,91	61,36	36,57	83,21	83,21	38,91	91,14	76,82	39,42	99,19	60,01	39,92	79,89	79,89	42,34	87,41	75,29	42,91	95,18	58,57	43,45	76,49	76,49	45,91	83,33	73,62	46,54	90,72	56,99	47,11
	32	88,24	88,24	35,66	94,60	89,17	36,10	102,88	72,38	36,57	85,58	85,58	38,96	91,15	87,74	39,41	99,17	71,03	39,91	82,71	82,71	42,46	87,44	85,28	42,90	95,16	69,59	43,44	79,59	79,59	46,11	83,36	83,36	46,53	90,70	68,01	47,10
18000	24	89,21	78,03	36,69	97,54	58,39	37,14	105,66	37,94	37,62	85,77	76,47	39,97	93,89	56,93	40,46	101,75	36,58	40,98	82,07	74,81	43,43	89,96	55,37	43,97	97,55	35,13	44,51	78,13	73,05	47,03	85,64	53,68	47,61	92,88	33,54	48,18
	27	89,27	89,27	36,67	97,52	74,21	37,13	105,64	53,95	37,63	85,87	85,87	39,93	93,88	72,76	40,45	101,72	52,59	40,98	82,23	82,23	43,37	89,96	71,20	43,96	97,52	51,14	44,51	78,38	78,38	46,94	85,64	69,51	47,60	92,85	49,55	48,18
	29,5	90,06	90,06	36,54	97,51	87,35	37,13	105,61	67,23	37,63	87,11	87,11	39,83	93,88	85,89	40,44	101,69	65,87	40,98	84,04	84,04	43,34	89,96	84,34	43,94	97,49	64,42	44,51	80,71	80,71	46,99	85,64	82,65	47,57	92,81	62,83	48,17
	32	93,40	93,40	36,69	97,51	97,51	37,12	105,56	80,46	37,62	90,52	90,52	40,02	93,88	93,88	40,42	101,65	79,09	40,97	87,39	87,39	43,54	90,00	90,00	43,90	97,45	77,64	44,50	83,94	83,94	47,22	85,74	85,74	47,51	92,76	76,04	48,16
20400	24	91,06	83,91	37,63	99,29	61,71	38,12	107,34	38,71	38,64	87,51	82,34	40,92	95,53	60,24	41,44	103,24	37,32	41,99	83,70	80,66	44,39	91,48	58,68	44,96	98,93	35,87	45,53	79,61	77,75	47,99	87,03	56,98	48,61	94,13	34,27	49,20
	27	91,19	91,19	37,56	99,26	79,64	38,11	107,31	56,86	38,65	87,74	87,74	40,82	95,51	78,17	41,43	103,21	55,47	42,00	84,08	84,08	44,26	91,47	76,61	44,94	98,90	54,02	45,54	80,20	80,20	47,82	87,02	74,91	48,58	94,10	52,42	49,20
	29,5	93,11	93,10	37,49	99,24	94,52	38,10	107,28	71,91	38,65	90,13	90,13	40,81	95,49	92,43	41,42	103,17	70,52	42,																		



VII-Fan Performance and Transmission Option

(Forward-Curved)

Tab. VII-01 - Fan Performance - Solution Plus 05 - Forward-Curved

Air flow (m³/h)	Total static pressure (mmca)																					
	10		15		20		25		30		35		40		45		50		55		60	
	rpm	bhp	rpm	bhp	rpm	bhp	rpm	bhp	rpm	bhp	rpm	bhp	rpm	bhp	rpm	bhp	rpm	bhp	rpm	bhp	rpm	bhp
2000	----	----	710	0,20	820	0,25	920	0,31	1020	0,37	1110	0,44	1200	0,51	1280	0,57	1370	0,65	1450	0,72	1530	0,79
2200	----	----	720	0,22	820	0,28	920	0,34	1010	0,41	1100	0,48	1180	0,55	1260	0,62	1340	0,70	1420	0,77	1500	0,85
2400	----	----	730	0,26	820	0,32	920	0,38	1010	0,45	1090	0,52	1170	0,60	1250	0,67	1330	0,75	1400	0,83	1470	0,91
2600	----	----	740	0,29	830	0,36	920	0,42	1000	0,50	1090	0,57	1160	0,65	1240	0,73	1310	0,81	1380	0,89	1450	0,98
2800	----	----	750	0,34	840	0,40	930	0,47	1010	0,55	1090	0,62	1160	0,70	1230	0,78	1300	0,87	1370	0,96	1440	1,04
3000	----	----	760	0,38	850	0,45	930	0,52	1010	0,60	1090	0,68	1160	0,76	1230	0,85	1300	0,94	1370	1,02	1430	1,12
3200	----	----	780	0,44	860	0,51	940	0,58	1020	0,66	1090	0,74	1160	0,83	1230	0,92	1300	1,01	1360	1,10	1420	1,19
3400	710	0,41	790	0,50	870	0,57	950	0,65	1030	0,73	1100	0,81	1170	0,90	1230	0,99	1300	1,08	1360	1,18	1420	1,28
3600	730	0,46	810	0,56	890	0,64	960	0,72	1040	0,80	1110	0,89	1170	0,98	1240	1,07	1300	1,17	1360	1,27	1420	1,37
3800	750	0,52	830	0,63	900	0,71	980	0,80	1050	0,88	1110	0,97	1180	1,06	1240	1,16	1300	1,26	1360	1,36	1420	1,46
4000	770	0,57	850	0,70	920	0,79	990	0,88	1060	0,97	1130	1,06	1190	1,16	1250	1,25	1310	1,36	1370	1,46	----	----

Tab. VII-02 - Fan Performance - Solution Plus 07 - Forward-Curved

Air flow (m³/h)	Total static pressure (mmca)																					
	10		15		20		25		30		35		40		45		50		55		60	
	rpm	bhp	rpm	bhp	rpm	bhp	rpm	bhp	rpm	bhp	rpm	bhp	rpm	bhp	rpm	bhp	rpm	bhp	rpm	bhp	rpm	bhp
3000	----	----	510	0,29	590	0,37	670	0,46	740	0,55	810	0,64	870	0,74	940	0,85	1000	0,96	1060	1,07	1110	1,19
3300	----	----	510	0,33	590	0,42	660	0,51	730	0,60	790	0,70	860	0,80	920	0,91	980	1,02	1040	1,14	1090	1,26
3600	----	----	510	0,38	590	0,47	660	0,56	720	0,66	790	0,77	850	0,87	910	0,98	960	1,10	1020	1,22	1070	1,34
3900	----	----	510	0,43	590	0,53	650	0,63	720	0,73	780	0,84	840	0,95	900	1,06	950	1,18	1000	1,31	1060	1,43
4200	----	----	520	0,48	590	0,59	650	0,69	720	0,80	780	0,92	830	1,03	890	1,15	940	1,27	990	1,40	1040	1,53
4500	----	----	530	0,55	590	0,66	660	0,77	720	0,88	770	1,00	830	1,12	880	1,25	940	1,37	990	1,50	1030	1,64
4800	----	----	540	0,61	600	0,73	660	0,85	720	0,97	770	1,10	830	1,22	880	1,35	930	1,48	980	1,61	1030	1,75
5100	----	----	550	0,69	610	0,81	670	0,94	720	1,07	780	1,20	830	1,33	880	1,46	930	1,60	970	1,73	1020	1,88
5400	500	0,64	560	0,77	610	0,90	670	1,04	730	1,17	780	1,30	830	1,44	880	1,58	930	1,72	970	1,86	1020	2,01
5700	510	0,72	570	0,85	620	1,00	680	1,14	730	1,28	780	1,42	830	1,56	880	1,71	930	1,85	970	2,00	1020	2,15
6000	----	----	580	0,95	630	1,10	690	1,25	740	1,40	780	1,54	830	1,69	880	1,84	930	1,99	970	2,15	1010	2,31

Tab. VII-03 - Transmission Options - Solution Plus 05 and 07 - Forward-Curved

TRANS. OPTION	UNIT MODEL	DISCH. TYPE	MOTOR	MOTOR RPM	VENT	MIN. RPM	MAX. RPM	Φ MOTOR	Φ VENT.													
A	05	VERT.	1	1720	TDA-10/10 L	701	1056	88	184													
B		HOR.																				
C		FLOOR																				
D		VERT.																				
E		HOR.	1,5	1710		1075	1619	88	120													
F		FLOOR																				
G		VERT.																				
H		HOR.																				
Y	FLOOR	07	1,5	1710	TDA-15/11 L	491	740	88	261													
A	VERT.																					
B	HOR.																					
C	FLOOR																					
D	VERT.		2	1700		697	1050	88	184													
E	HOR.																					
F	FLOOR																					
G	VERT.																					
H	HOR.	3	1730	692	1044	88	184															
Y	FLOOR																					
J	VERT.																					
K	HOR.																					
L	FLOOR																					

- Note:
- (1) Total static pressure in fan performance tables is at standard density. Standard density is based on air density at 21°C and a barometric pressure of 760 mmHg. This total pressure is the external static pressure required to the fan under operating condition, and shall include the pressure drop sums occurring in the components placed along the air flow and the typical drops in the duct that takes the expelled air through the fan.
 - (2) Heat produced by fan motor (MBh) = 3.15 x BHP

Fan Performance and Transmission Option

(Forward-Curved)

Tab. VII-04 - Fan Performance - Solution Plus 10 - Forward-Curved

Air flow (m ³ /h)	Total static pressure (mmca)																					
	10		15		20		25		30		35		40		45		50		55		60	
	rpm	bhp	rpm	bhp	rpm	bhp	rpm	bhp	rpm	bhp	rpm	bhp	rpm	bhp	rpm	bhp	rpm	bhp	rpm	bhp	rpm	bhp
4400	----	----	510	0,44	600	0,58	670	0,72	750	0,88	820	1,05	880	1,23	950	1,42	1010	1,62	1070	1,82	1130	2,04
4800	----	----	510	0,49	590	0,63	670	0,79	740	0,95	810	1,12	870	1,30	930	1,49	990	1,69	1050	1,90	1110	2,12
5200	----	----	510	0,55	590	0,70	660	0,86	730	1,02	800	1,20	860	1,39	920	1,58	980	1,78	1030	1,99	1090	2,21
5600	----	----	520	0,62	590	0,77	660	0,93	730	1,10	790	1,29	850	1,48	910	1,67	970	1,88	1020	2,10	1070	2,32
6000	----	----	520	0,69	590	0,85	660	1,02	730	1,19	790	1,38	850	1,57	900	1,78	960	1,99	1010	2,21	1060	2,43
6400	450	0,61	530	0,77	600	0,93	660	1,11	720	1,29	780	1,48	840	1,68	900	1,89	950	2,10	1000	2,33	1050	2,56
6800	460	0,70	530	0,86	600	1,03	660	1,21	720	1,40	780	1,59	840	1,80	890	2,01	940	2,23	1000	2,46	1050	2,69
7200	470	0,79	540	0,95	600	1,13	670	1,32	730	1,51	780	1,72	840	1,92	890	2,14	940	2,37	990	2,60	1040	2,84
7600	480	0,89	550	1,06	610	1,24	670	1,44	730	1,64	780	1,85	840	2,06	890	2,28	940	2,51	990	2,75	1030	3,00
8000	490	1,00	560	1,18	620	1,37	670	1,57	730	1,77	780	1,99	840	2,21	890	2,44	940	2,67	980	2,91	1030	3,16

Tab. VII-05 - Fan Performance - Solution Plus 12,5 - Forward-Curved

Air flow (m ³ /h)	Total static pressure (mmca)																					
	10		15		20		25		30		35		40		45		50		55		60	
	rpm	bhp	rpm	bhp	rpm	bhp	rpm	bhp	rpm	bhp	rpm	bhp	rpm	bhp	rpm	bhp	rpm	bhp	rpm	bhp	rpm	bhp
5500	----	----	660	0,55	770	0,74	870	0,95	960	1,18	1040	1,43	----	----	----	----	----	----	----	----	----	----
6000	----	----	660	0,60	770	0,80	860	1,01	950	1,24	1030	1,50	1110	1,77	1180	2,05	----	----	----	----	----	----
6500	550	0,49	660	0,67	770	0,87	860	1,08	950	1,32	1030	1,57	1100	1,84	1170	2,13	1240	2,43	----	----	----	----
7000	550	0,56	660	0,74	760	0,94	860	1,16	940	1,40	1020	1,66	1100	1,93	1170	2,22	1240	2,52	1300	2,84	1360	3,18
7500	560	0,64	670	0,82	760	1,03	850	1,25	940	1,50	1020	1,75	1090	2,03	1160	2,32	1230	2,62	1290	2,94	1360	3,28
8000	570	0,72	670	0,91	770	1,12	850	1,35	940	1,60	1010	1,86	1090	2,14	1160	2,43	1230	2,74	1290	3,06	1350	3,39
8500	580	0,82	680	1,01	770	1,23	850	1,46	940	1,71	1010	1,98	1090	2,26	1150	2,56	1220	2,86	1280	3,19	1350	3,52
9000	590	0,92	680	1,12	770	1,34	860	1,58	940	1,84	1010	2,11	1080	2,39	1150	2,69	1220	3,00	1280	3,33	1340	3,67
9500	600	1,04	690	1,25	780	1,47	860	1,72	940	1,98	1010	2,25	1080	2,54	1150	2,84	1210	3,16	1280	3,49	1340	3,83
10000	610	1,17	700	1,38	780	1,61	860	1,86	940	2,12	1010	2,40	1080	2,70	1150	3,01	1210	3,32	1270	3,66	1330	4,00

Tab. VII-06 - Transmission Options - Solution Plus 10 and 12 - Forward-Curved

TRANS. OPTION	UNIT MODEL	DISCH. TYPE	MOTOR	RPM MOTOR	VENT	MIN. RPM	MAX. RPM	ΦMOTOR	Φ VENT.		
A	10	VERT.	2	1700	TDA-15/11 L	445	671	88	261		
B		HOR.									
C		FLOOR									
D		VERT.								3	1730
E		HOR.									
F		FLOOR									
G		VERT.	4	1715							
H		HOR.									
Y		FLOOR									
J		VERT.	12	2		1700	TDA-12/12 T2L	542	817	88	235
K		HOR.									
L		FLOOR									
A	VERT.	3		1730							
B	HOR.										
C	FLOOR										
D	VERT.	4		1715							
E	HOR.										
Y	FLOOR										

Note:

- (1) Total static pressure in fan performance tables is at standard density. Standard density is based on air density at 21°C and a barometric pressure of 760 mmHg. This total pressure is the external static pressure required to the fan under operating condition, and shall include the pressure drop sums occurring in the components placed along the air flow and the typical drops in the duct that takes the expelled air through the fan.
- (2) Heat produced by fan motor (MBh) = 3.15 x BHP



Fan Performance and Transmission Option

(Forward-Curved)

Tab. VII-07 - Fan Performance - Solution Plus 15 - Forward-Curved

Air flow (m³/h)	Total static pressure (mmca)																					
	10		15		20		25		30		35		40		45		50		55		60	
	rpm	bhp	rpm	bhp	rpm	bhp	rpm	bhp	rpm	bhp	rpm	bhp	rpm	bhp	rpm	bhp	rpm	bhp	rpm	bhp	rpm	bhp
6000	440	0,46	530	0,62	620	0,79	700	0,98	770	1,17	850	1,38	920	1,60	980	1,82	1050	2,06	1110	2,31	1170	2,56
6600	440	0,53	530	0,71	620	0,89	690	1,09	760	1,29	830	1,51	900	1,73	960	1,96	1030	2,20	1090	2,46	1150	2,72
7200	450	0,62	540	0,81	620	1,01	690	1,21	760	1,42	830	1,65	890	1,88	950	2,12	1010	2,37	1070	2,62	1130	2,89
7800	460	0,71	540	0,92	620	1,13	690	1,35	750	1,57	820	1,80	880	2,04	940	2,29	1000	2,54	1050	2,81	1110	3,08
8400	470	0,82	550	1,04	620	1,27	690	1,49	750	1,73	830	1,97	880	2,22	930	2,47	990	2,74	1040	3,01	1100	3,29
9000	480	0,93	550	1,18	620	1,42	690	1,66	750	1,90	810	2,15	870	2,41	930	2,68	980	2,95	1040	3,23	1090	3,52
9600	490	1,06	560	1,32	630	1,58	690	1,83	750	2,09	810	2,35	870	2,62	920	2,90	970	3,18	1030	3,47	1080	3,77
10200	510	1,21	570	1,48	640	1,75	700	2,02	760	2,30	810	2,57	870	2,85	920	3,14	970	3,43	1020	3,73	1070	4,04
10800	520	1,37	580	1,65	650	1,94	700	2,23	760	2,52	820	2,80	870	3,10	920	3,39	970	3,70	1020	4,01	1070	4,32
11400	540	1,55	600	1,83	660	2,14	710	2,45	770	2,75	820	3,05	870	3,36	920	3,67	970	3,98	1020	4,31	1070	4,63
12000	----	----	610	2,04	670	2,36	720	2,68	770	3,00	830	3,32	880	3,64	930	3,96	970	4,29	1020	4,62	1070	4,96

Tab. VII-08 - Fan Performance - Solution Plus 20- Forward-Curved

Air flow (m³/h)	Total static pressure (mmca)																					
	10		15		20		25		30		35		40		45		50		55		60	
	rpm	bhp	rpm	bhp	rpm	bhp	rpm	bhp	rpm	bhp	rpm	bhp	rpm	bhp	rpm	bhp	rpm	bhp	rpm	bhp	rpm	bhp
9000	----	----	540	0,98	630	1,27	710	1,59	780	1,93	850	2,30	920	2,68	990	3,09	1050	3,51	1120	3,96	----	----
9800	450	0,81	540	1,09	620	1,40	700	1,73	770	2,08	840	2,45	910	2,85	980	3,26	1040	3,69	1100	4,14	----	----
10600	450	0,93	540	1,22	620	1,54	700	1,88	770	2,24	840	2,63	900	3,03	960	3,45	1020	3,88	1080	4,34	1140	4,81
11400	460	1,06	540	1,37	620	1,70	690	2,05	760	2,42	830	2,82	890	3,23	950	3,65	1010	4,10	1070	4,56	1130	5,04
12200	470	1,20	550	1,53	620	1,87	690	2,24	760	2,62	830	3,02	890	3,44	950	3,88	1000	4,34	1060	4,81	1110	5,29
13000	480	1,37	550	1,70	630	2,06	700	2,44	760	2,84	820	3,25	880	3,68	940	4,13	1000	4,59	1050	5,07	1100	5,57
13800	490	1,55	560	1,90	630	2,27	700	2,66	760	3,07	820	3,50	880	3,94	940	4,40	990	4,87	1040	5,36	1100	5,87
14600	500	1,75	570	2,11	640	2,50	700	2,90	760	3,32	820	3,76	880	4,22	930	4,69	990	5,17	1040	5,67	1090	6,18
15400	510	1,97	580	2,35	640	2,75	710	3,16	770	3,60	820	4,05	880	4,52	930	5,00	980	5,49	1030	6,00	1080	6,53
16200	520	2,21	590	2,60	650	3,02	710	3,45	770	3,89	830	4,36	880	4,84	930	5,33	980	5,84	1030	6,36	1080	6,89
17000	540	2,48	600	2,88	660	3,31	720	3,75	770	4,21	830	4,69	880	5,18	930	5,69	980	6,21	1030	6,74	1080	7,29

Tab. VII-09 - Transmission Options - Solution Plus 15 and 20 - Forward-Curved

TRANS. OPTION	UNIT MODEL	DISCH. TYPE	MOTOR	RPM MOTOR	VENT	MIN. RPM	MAX. RPM	Φ MOTOR	Φ VENT.						
A	15	VERT.	2	1700	TDA-15/11/T2L	440	671	88	261						
B		HOR.													
C		FLOOR													
D		VERT.													
E		HOR.													
F		FLOOR													
G		VERT.	3	1730		625	795	142	346						
H		HOR.													
Y		FLOOR													
J		VERT.													
K		HOR.													
L		FLOOR													
M		VERT.	4	1715		724	921	142	296						
N		HOR.													
P		FLOOR													
Q	VERT.														
R	HOR.														
S	FLOOR														
T	VERT.	5	1735	959	1220	142	226								
U	HOR.														
V	FLOOR														
A	VERT.							20	2	1700	TDA-15/15-T2L	445	671	88	286
B	HOR.														
C	FLOOR														
D	VERT.														
E	HOR.														
F	FLOOR														
G	VERT.	3	1730	544	692	142	296								
H	HOR.														
Y	FLOOR														
J	VERT.														
K	HOR.														
L	FLOOR														
M	VERT.	5	1735	626	797	142	346								
N	HOR.														
P	FLOOR														
Q	VERT.														
R	HOR.														
S	FLOOR														
T	VERT.	7,5	1740	885	1125	142	245								
U	HOR.														
V	FLOOR														
						897	1142	142	245						

Note:

- (1) Total static pressure in fan performance tables is at standard density. Standard density is based on air density at 21°C and a barometric pressure of 760 mmHg. This total pressure is the external static pressure required to the fan under operating condition, and shall include the pressure drop sums occurring in the components placed along the air flow and the typical drops in the duct that takes the expelled air through the fan.
- (2) Heat produced by fan motor (MBh) = 3.15 x BHP

Fan Performance and Transmission Option

(Forward-Curved)

Tab. VII-10 - Fan Performance - Solution Plus 25 - Forward-Curved

Air flow (m³/h)	Total static pressure (mmca)																					
	1 0		1 5		2 0		2 5		3 0		3 5		4 0		4 5		5 0		5 5		6 0	
	rpm	bhp	rpm	bhp	rpm	bhp	rpm	bhp	rpm	bhp	rpm	bhp	rpm	bhp	rpm	bhp	rpm	bhp	rpm	bhp	rpm	bhp
12000	----	----	460	1,18	530	1,56	600	1,97	660	2,41	720	2,87	----	----	----	----	----	----	----	----	----	----
13000	----	----	460	1,30	530	1,69	600	2,12	660	2,57	720	3,04	770	3,54	----	----	----	----	----	----	----	----
14000	----	----	460	1,43	530	1,84	590	2,28	650	2,74	710	3,22	770	3,73	820	4,24	870	4,79	----	----	----	----
15000	----	----	460	1,57	530	2,00	590	2,45	650	2,93	710	3,43	760	3,95	810	4,47	860	5,03	910	5,61	----	----
16000	----	----	470	1,73	530	2,17	590	2,64	650	3,13	700	3,64	750	4,18	800	4,70	850	5,28	900	5,87	940	6,48
17000	----	----	470	1,90	530	2,36	590	2,84	650	3,35	700	3,87	750	4,42	800	4,96	840	5,55	890	6,15	940	6,78
18000	----	----	480	2,08	540	2,56	590	3,06	650	3,58	700	4,12	750	4,68	800	5,27	840	5,83	890	6,45	930	7,09
19000	----	----	480	2,28	540	2,78	600	3,29	650	3,83	700	4,39	750	4,96	790	5,56	840	6,13	880	6,77	920	7,42
20000	----	----	490	2,50	540	3,01	600	3,54	650	4,10	700	4,67	750	5,26	790	5,87	830	6,45	880	7,10	920	7,76
21000	440	2,23	490	2,73	550	3,26	600	3,81	650	4,38	700	4,97	750	5,58	790	6,15	830	6,79	870	7,45	920	8,13

Tab. VII-11 - Fan Performance - Solution Plus 30 - Forward-Curved

Air flow (m³/h)	Total static pressure (mmca)																					
	rpm	bhp	rpm	bhp	rpm	bhp	rpm	bhp	rpm	bhp	rpm	bhp	rpm	bhp	rpm	bhp	rpm	bhp	rpm	bhp		
15000	----	----	460	1,57	530	2,00	590	2,45	650	2,93	700	3,40	760	3,92	810	4,47	860	5,03	910	5,61	----	----
16000	----	----	470	1,73	530	2,17	590	2,64	650	3,13	700	3,61	750	4,15	800	4,70	850	5,28	900	5,87	940	6,48
17000	----	----	470	1,90	530	2,36	590	2,84	650	3,35	700	3,84	750	4,39	800	4,96	840	5,55	890	6,15	940	6,78
18000	----	----	480	2,08	540	2,56	590	3,06	650	3,58	700	4,09	750	4,65	800	5,27	840	5,83	890	6,45	930	7,09
19000	----	----	480	2,28	540	2,78	600	3,29	650	3,83	700	4,34	740	4,92	790	5,56	840	6,13	880	6,77	920	7,42
20000	----	----	490	2,50	540	3,01	600	3,54	650	4,10	700	4,62	740	5,21	790	5,87	830	6,45	880	7,10	920	7,76
21000	440	2,23	490	2,73	550	3,26	600	3,81	650	4,38	700	4,92	740	5,52	790	6,15	830	6,79	870	7,45	920	8,13
22000	440	2,41	500	2,93	550	3,48	600	4,04	650	4,63	700	5,23	740	5,85	790	6,49	830	7,15	870	7,83	910	8,52
23000	450	2,65	500	3,20	560	3,76	610	4,34	660	4,94	700	5,56	750	6,20	790	6,86	830	7,53	870	8,22	910	8,93
24000	460	2,92	510	3,48	560	4,06	610	4,66	660	5,28	700	5,92	750	6,57	790	7,24	830	7,93	870	8,64	----	----
25000	470	3,20	520	3,78	570	4,38	620	5,00	660	5,64	710	6,29	750	6,96	790	7,65	830	8,35	870	9,07	----	----

Tab. VII-12 - Transmission Options - Solution Plus 25 and 30

TRANSM. OPTION	UNIT MODEL	DISCH. TYPE	MOTOR	MOTOR RPM	VENT	MIN. RPM	MAX. RPM	Φ MOTOR	Φ VENT.		
A	25	VERT.	3	1730	TDA-18/18-T2L	433	551	142	499		
B		HOR.									
C		FLOOR				5	1735	581	739	142	372
D		VERT.									
E		HOR.				7,5	1740	434	552	142	499
F		FLOOR									
G		VERT.				10	1760	583	741	142	372
H		HOR.									
Y		FLOOR				7,5	1740	732	931	142	296
J		VERT.									
K		HOR.	10	1760		677	861	142	321		
L		FLOOR									
M		VERT.	7,5	1740		734	934	142	296		
N		HOR.									
P		FLOOR	10	1760		743	945	142	296		
Q		VERT.									
R		HOR.	3	1730		433	551	142	499		
S		FLOOR									
T		VERT.	5	1735		581	739	142	372		
U		HOR.									
V	FLOOR	7,5	1740	434	552	142	499				
X	VERT.										
Z	HOR.	10	1760	583	741	142	372				
W	FLOOR										
A	30	VERT.	3	1730	TDA-18/18-T2L	433	551	142	499		
B		HOR.									
C		FLOOR				5	1735	581	739	142	372
D		VERT.									
E		HOR.				7,5	1740	434	552	142	499
F		FLOOR									
G		VERT.				10	1760	583	741	142	372
H		HOR.									
Y		FLOOR				7,5	1740	732	931	142	296
J		VERT.									
K		HOR.	10	1760		677	861	142	321		
L		FLOOR									
M		VERT.	7,5	1740		734	934	142	296		
N		HOR.									
P		FLOOR	10	1760		743	945	142	296		
Q		VERT.									
R		HOR.	3	1730		433	551	142	499		
S		FLOOR									
T		VERT.	5	1735		581	739	142	372		
U		HOR.									
V	FLOOR	7,5	1740	434	552	142	499				
X	VERT.										
Z	HOR.	10	1760	583	741	142	372				
W	FLOOR										

Note:
 (1) Total static pressure in fan performance tables is at standard density. Standard density is based on air density at 21°C and a barometric pressure of 760 mmHg. This total pressure is the external static pressure required to the fan under operating condition, and shall include the pressure drop sums occurring in the components placed along the air flow and the typical drops in the duct that takes the expelled air through the fan.
 (2) Heat produced by fan motor (MBh) = 3.15 x BHP



Fan Performance and Transmission Option

(Forward-Curved)

Tab. VII-13 - Fan Performance - Solution Plus 35 - Forward-Curved

Air flow (m ³ /h)	Total static pressure (mmca)																					
	10		15		20		25		30		35		40		45		50		55		60	
	rpm	bhp	rpm	bhp	rpm	bhp	rpm	bhp	rpm	bhp	rpm	bhp	rpm	bhp	rpm	bhp	rpm	bhp	rpm	bhp	rpm	bhp
17500	----	----	470	1,73	550	2,30	620	2,91	690	3,56	750	4,25	----	----	----	----	----	----	----	----	----	----
19000	----	----	470	1,90	540	2,49	610	3,12	680	3,80	740	4,50	800	5,25	----	----	----	----	----	----	----	----
20500	----	----	470	2,09	540	2,70	610	3,36	670	4,05	730	4,78	790	5,54	840	6,34	----	----	----	----	----	----
22000	----	----	470	2,30	540	2,94	610	3,61	670	4,33	730	5,07	780	5,86	840	6,67	890	7,52	940	8,35	----	----
23500	----	----	480	2,53	550	3,19	610	3,89	670	4,62	720	5,39	780	6,20	830	7,03	880	7,89	930	8,74	----	----
25000	----	----	480	2,78	550	3,47	610	4,19	670	4,94	720	5,74	770	6,56	820	7,41	870	8,30	920	9,16	----	----
26500	----	----	490	3,05	550	3,76	610	4,51	670	5,29	720	6,10	770	6,95	820	7,82	870	8,72	910	9,60	950	10,88
28000	----	----	490	3,35	550	4,08	610	4,85	670	5,66	720	6,49	770	7,36	820	8,26	860	9,18	910	10,06	950	11,04
29500	440	2,94	500	3,67	560	4,43	620	5,23	670	6,05	720	6,91	770	7,80	820	8,72	860	9,67	900	10,56	950	11,56
31000	450	3,26	510	4,01	560	4,80	620	5,62	670	6,48	720	7,36	770	8,27	820	9,21	860	10,18	900	11,09	940	12,10

Tab. VII-14 - Transmission Options - Solution Plus 35 - Forward-Curved

TRANSM. OPTION	UNIT MODEL	DISCH. TYPE	MOTOR	MOTOR RPM	VENT	MIN. RPM	MAX. RPM	Φ MOTOR	Φ VENT.				
A	35	VERT.	3	1730	TDA-18/18-T3R	433	551	142	499				
B		HOR.											
C		FLOOR											
D		VERT.											
E		HOR.											
F		FLOOR											
G		VERT.	5	1735		434	552	142	499				
H		HOR.											
Y		FLOOR											
J		VERT.											
K		HOR.											
L		FLOOR											
M		VERT.	7,5	1740		732	931	142	296				
N		HOR.											
P		FLOOR											
Q		VERT.											
R		HOR.											
S		FLOOR											
T		VERT.	10	1760		734	934	142	296				
U		HOR.											
V	FLOOR												
X	VERT.	15			1760					743	945	142	296
Z	HOR.												
W	FLOOR												

- Note:
- (1) Total static pressure in fan performance tables is at standard density. Standard density is based on air density at 21°C and a barometric pressure of 760 mmHg. This total pressure is the external static pressure required to the fan under operating condition, and shall include the pressure drop sums occurring in the components placed along the air flow and the typical drops in the duct that takes the expelled air through the fan.
 - (2) Heat produced by fan motor (MBh) = 3.15 x BHP

Fan Performance and Transmission Option

(Forward-Curved)

Tab. VII-15 - Fan Performance - Solution Plus 40 - Forward-Curved

Air flow (m³/h)	Total static pressure (mmca)																					
	10		15		20		25		30		35		40		45		50		55		60	
	rpm	bhp	rpm	bhp	rpm	bhp	rpm	bhp	rpm	bhp	rpm	bhp	rpm	bhp	rpm	bhp	rpm	bhp	rpm	bhp	rpm	bhp
20000	—	—	470	2.03	540	2.63	610	3.28	670	3.96	730	4.68	790	5.44	850	6.23	—	—	—	—	—	—
21500	—	—	470	2.23	540	2.86	610	3.53	670	4.23	730	4.97	780	5.75	840	6.56	890	7.40	—	—	—	—
23000	—	—	480	2.45	540	3.10	610	3.79	670	4.52	720	5.28	780	6.08	830	6.91	880	7.76	930	8.61	980	9.52
24500	—	—	480	2.69	550	3.37	610	4.09	670	4.84	720	5.62	770	6.43	830	7.28	880	8.16	920	9.01	970	9.95
26000	—	—	490	2.96	550	3.66	610	4.40	670	5.17	720	5.98	770	6.81	820	7.68	870	8.58	910	9.45	960	10.40
27500	—	—	490	3.25	550	3.97	610	4.74	670	5.53	720	6.36	770	7.22	820	8.11	870	9.03	910	9.91	950	10.88
29000	430	2.84	500	3.56	560	4.31	610	5.10	670	5.92	720	6.77	770	7.65	820	8.56	860	9.50	900	10.4	950	11.38
30500	440	3.15	500	3.89	560	4.67	620	5.49	670	6.33	720	7.21	770	8.11	820	9.04	860	10.00	900	10.9	940	11.92
32000	450	3.48	510	4.26	570	5.06	620	5.90	670	6.77	720	7.67	770	8.60	820	9.56	860	10.54	900	11.5	940	12.48
33500	460	3.84	520	4.65	570	5.48	630	6.35	680	7.24	720	8.17	770	9.12	820	10.10	860	11.10	900	12	940	13.08
35000	470	4.23	530	5.07	580	5.93	630	6.82	680	7.74	730	8.69	770	9.67	820	10.67	860	11.70	900	12.6	—	—

Tab. VII-16 - Transmission Options - Solution Plus 40 - Forward-Curved

TRANSM. OPTION	UNIT MODEL	DISCH. TYPE	MOTOR	RPM MOTOR	VENT	MIN. RPM	MAX. RPM	Φ MOTOR	Φ VENT.
A	40	VERT.	5	1735	TDA-18/18-T3R	434	552	142	499
B		HOR.							
C		FLOOR							
D		VERT.							
E		HOR.							
F		FLOOR							
G		VERT.	7.5	1440		677	861	142	321
H		HOR.							
Y		FLOOR							
J		VERT.							
K		HOR.							
L		FLOOR							
M		VERT.	10	1760		743	945	142	296
N		HOR.							
P		FLOOR							
Q		VERT.							
R		HOR.							
S		FLOOR							
T		VERT.	15	1760		957	-	161	296
U		HOR.							
V	FLOOR								

Note:

- Total static pressure in fan performance tables is at standard density. Standard density is based on air density at 21°C and a barometric pressure of 760 mmHg. This total pressure is the external static pressure required to the fan under operating condition, and shall include the pressure drop sums occurring in the components placed along the air flow and the typical drops in the duct that takes the expelled air through the fan.
- Heat produced by fan motor (MBh) = 3.15 x BHP



Fan Performance and Transmission Option

(Forward-Curved)

Tab. VII-17 - Fan Performance - Solution Plus 50 - Forward-Curved

Air flow (m³/h)	Total static pressure (mmca)																					
	10		15		20		25		30		35		40		45		50		55		60	
	rpm	bhp	rpm	bhp	rpm	bhp	rpm	bhp	rpm	bhp	rpm	bhp	rpm	bhp	rpm	bhp	rpm	bhp	rpm	bhp	rpm	bhp
25000	----	----	480	2,78	550	3,47	610	4,19	670	4,94	720	5,74	770	6,56	820	7,41	870	8,30	920	9,16	----	----
26500	----	----	490	3,05	550	3,76	610	4,51	670	5,29	720	6,10	770	6,95	820	7,82	870	8,72	910	9,60	----	----
28000	----	----	490	3,35	550	4,08	610	4,85	670	5,66	720	6,49	770	7,36	820	8,26	860	9,18	910	10,06	950	11,04
29500	440	2,94	500	3,67	560	4,43	620	5,23	670	6,05	720	6,91	770	7,80	820	8,72	860	9,67	900	10,56	950	11,56
31000	450	3,26	510	4,01	560	4,80	620	5,62	670	6,48	720	7,36	770	8,27	820	9,21	860	10,18	900	11,09	940	12,10
32500	450	3,60	510	4,38	570	5,20	620	6,05	670	6,93	720	7,83	770	8,77	820	9,73	860	10,72	900	11,64	940	12,68
34000	460	3,97	520	4,78	580	5,63	630	6,50	680	7,41	730	8,34	770	9,30	820	10,28	860	11,30	900	12,23	940	13,29
35500	480	4,37	530	5,21	580	6,08	630	6,99	680	7,91	730	8,87	770	9,86	820	10,87	860	11,90	900	12,84	940	13,92
37000	490	4,80	540	5,67	590	6,57	640	7,50	690	8,46	730	9,44	780	10,45	820	11,48	860	12,54	900	13,49	940	14,60
38500	500	5,26	550	6,16	600	7,09	650	8,05	690	9,03	740	10,04	780	11,07	820	12,13	860	13,22	900	14,17	----	----
40000	510	5,75	560	6,68	610	7,64	650	8,62	700	9,64	740	10,67	790	11,73	830	12,82	870	13,92	900	14,89	----	----

Tab. VII-18 - Transmission Options - Solution Plus 50 - Forward-Curved

TRANSM. OPTION	UNIT MODEL	DISCH. TYPE	MOTOR	RPM MOTOR	VENT	MIN. RPM	MAX. RPM	Φ MOTOR	Φ VENT.
A	50	VERT.	5	1735	TDA-18/18-T3R	434	552	142	499
B		HOR.							
C		FLOOR							
D		VERT.							
E		HOR.							
F		FLOOR							
G		VERT.	7,5	1740		677	861	142	321
H		HOR.							
Y		FLOOR							
J		VERT.							
K		HOR.							
L		FLOOR							
M		VERT.	10	1760		685	871	142	321
N		HOR.							
P		FLOOR							
Q		VERT.							
R		HOR.							
S		FLOOR							
T		VERT.	15	1760		768	-	151	346
U		HOR.							
V		FLOOR							
X		VERT.							
Z		HOR.							
W		FLOOR							
1		VERT.	15	1760		957	-	161	296
2		HOR.							
3		FLOOR							

- Note:
- (1) Total static pressure in fan performance tables is at standard density. Standard density is based on air density at 21°C and a barometric pressure of 760 mmHg. This total pressure is the external static pressure required to the fan under operating condition, and shall include the pressure drop sums occurring in the components placed along the air flow and the typical drops in the duct that takes the expelled air through the fan.
 - (2) Heat produced by fan motor (MBh) = 3.15 x BHP

Fan Performance and Transmission Option

(Backward-Curved)

Tab. VII-19 - Fan Performance - Solution Plus 05 - Backward-Curved

Air flow (m ³ /h)	Total static pressure (mmca)																										
	40		50		60		70		80		90		100		110		120		130		140		150		160		
	rpm	bhp	rpm	bhp	rpm	bhp	rpm	bhp	rpm	bhp	rpm	bhp	rpm	bhp	rpm	bhp	rpm	bhp	rpm	bhp	rpm	bhp	rpm	bhp	rpm	bhp	rpm
2000			1918	0,53	2042	0,63	2165	0,74	2287	0,85	2410	0,97	2534	1,10	2660	1,24	2788	1,38	2920	1,54	3054	1,71	3193	1,89	3336	2,09	
2200			1988	0,60	2104	0,70	2217	0,81	2329	0,92	2440	1,05	2552	1,17	2663	1,31	2776	1,45	2890	1,60	3006	1,76	3124	1,92	3244	2,10	
2400	1948	0,57	2064	0,68	2174	0,78	2280	0,90	2385	1,01	2488	1,13	2590	1,26	2692	1,4	2794	1,54	2896	1,68	2999	1,84	3104	2,00	3209	2,16	
2600	2033	0,65	2144	0,76	2249	0,87	2351	0,99	2449	1,11	2546	1,24	2642	1,37	2736	1,5	2831	1,64	2925	1,79	3019	1,94	3113	2,10	3208	2,26	
2800	2120	0,74	2227	0,86	2329	0,98	2426	1,10	2521	1,22	2613	1,35	2703	1,49	2792	1,62	2880	1,77	2968	1,91	3056	2,06	3143	2,22	3230	2,38	
3000	2209	0,85	2313	0,96	2412	1,09	2506	1,21	2596	1,34	2685	1,48	2771	1,62	2856	1,76	2940	1,90	3022	2,05	3105	2,21	3187	2,37	3268	2,53	
3200	2299	0,96	2401	1,08	2497	1,21	2588	1,34	2676	1,48	2761	1,62	2844	1,76	2925	1,91	3005	2,05	3084	2,21	3163	2,36	3240	2,53	3317	2,69	
3400	2391	1,08	2490	1,21	2584	1,35	2673	1,48	2758	1,62	2841	1,77	2921	1,92	2999	2,07	3076	2,22	3152	2,38	3227	2,54	3301	2,70	3375	2,87	
3600	2483	1,22	2581	1,36	2672	1,49	2759	1,64	2842	1,78	2923	1,93	3001	2,08	3077	2,24	3151	2,40	3225	2,56	3297	2,73	3368	2,89	----	----	
3800	2577	1,38	2672	1,51	2762	1,66	2847	1,80	2928	1,96	3007	2,11	3083	2,27	3157	2,43	3230	2,59	3301	2,76	3370	2,93	----	----	----	----	
4000	2671	1,55	2765	1,69	2853	1,83	2936	1,99	3016	2,14	3093	2,30	3167	2,47	3240	2,63	3310	2,80	3379	2,97	3447	3,15	----	----	----	----	

Tab. VII-20 - Fan Performance - Solution Plus 07 - Backward-Curved

Air flow (m ³ /h)	Total static pressure (mmca)																										
	40		50		60		70		80		90		100		110		120		130		140		150		160		
	rpm	bhp	rpm	bhp	rpm	bhp	rpm	bhp	rpm	bhp	rpm	bhp	rpm	bhp	rpm	bhp	rpm	bhp	rpm	bhp	rpm	bhp	rpm	bhp	rpm	bhp	rpm
3000	1315	0,60	1430	0,74	1538	0,89	1641	1,04	1740	1,19	1834	1,35	1925	1,51	2012	1,68	2097	1,84	2180	2,01	2260	2,18	2339	2,35	----	----	
3300	1354	0,67	1463	0,82	1537	0,97	1667	1,14	1762	1,30	1853	1,47	1942	1,64	2027	1,82	2109	2,00	2189	2,18	2267	2,36	2343	2,54	2418	2,72	
3600	1397	0,74	1502	0,90	1601	1,07	1697	1,24	1789	1,42	1877	1,60	1963	1,78	2046	1,96	2126	2,15	2204	2,34	2280	2,54	2354	2,73	2426	2,93	
3900	1444	0,83	1544	1,00	1639	1,17	1731	1,35	1820	1,54	1905	1,73	1988	1,92	2069	2,12	2147	2,31	2223	2,52	2297	2,72	2369	2,93	2440	3,14	
4200	1493	0,92	1589	1,10	1681	1,28	1769	1,47	1854	1,66	1937	1,86	2017	2,07	2096	2,27	2172	2,48	2246	2,69	2318	2,91	2389	3,13	2458	3,35	
4500	1545	1,02	1637	1,21	1725	1,40	1810	1,60	1893	1,80	1972	2,01	2050	2,22	2126	2,44	2200	2,66	2272	2,88	2342	3,10	2411	3,33	2479	3,56	
4800	1598	1,12	1687	1,32	1772	1,53	1854	1,73	1934	1,95	2011	2,16	2086	2,38	2160	2,61	2231	2,84	2301	3,07	2370	3,30	2437	3,54	2505	3,78	
5100	1654	1,24	1739	1,45	1822	1,66	1901	1,88	2040	2,33	2052	2,33	2125	2,56	2196	2,79	2266	3,03	2334	3,27	2401	3,52	2466	3,76	2531	4,01	
5400	1710	1,37	1793	1,59	1873	1,81	1949	2,04	2024	2,27	2096	2,50	2167	2,74	2236	2,98	2303	3,23	2370	3,48	2435	3,74	2498	3,99	2561	4,25	
5700	1767	1,51	1848	1,74	1926	1,97	2000	2,20	2072	2,44	2142	2,69	2211	2,94	2278	3,19	2343	3,44	2408	3,70	2471	3,97	2533	4,23	----	----	
6000	1825	1,66	1905	1,89	1980	2,14	2052	2,38	2122	2,63	2190	2,89	2257	3,14	2322	3,40	2386	3,67	2448	3,94	2510	4,21	----	----	----	----	

Tab. VII-21 - Transmission Options - Solution Plus 05 and 07 - Backward-Curved

TRANSM. OPTION	UNIT MODEL	DISCH. TYPE	MOTOR	RPM MOTOR	VENT	MIN. RPM	MAX. RPM	Φ MOTOR	Φ VENT.
A	05	VERT.	1	3420	LMD315Q	1953	2631	88	133
B		HOR.							
C		FLOOR							
D		VERT.	2	3385		2391	3226	88	108
E		HOR.							
F		FLOOR							
G		VERT.	3	3450		3167	4028	142	143
H		HOR.							
Y		FLOOR							
A	07	VERT.	2	3385	LMD400Q	1236	1667	88	209
B		HOR.							
C		FLOOR							
D		VERT.							
E		HOR.							
F		FLOOR							
G		VERT.	3	3450		1760	2239	142	245
H		HOR.							
Y		FLOOR							
J		VERT.	5	3500		2255	2868	142	194
K		HOR.							
L		FLOOR							

Note:

- (1) Total static pressure in fan performance tables is at standard density. Standard density is based on air density at 21°C and a barometric pressure of 760 mmHg. This total pressure is the external static pressure required to the fan under operating condition, and shall include the pressure drop sums occurring in the components placed along the air flow and the typical drops in the duct that takes the expelled air through the fan.
- (2) Heat produced by fan motor (MBh) = 3.15 x BHP



Fan Performance and Transmission Option

(Backward-Curved)

Tab. VII-22 - Fan Performance - Solution Plus 10 - Backward-Curved

Air flow (m³/h)	Total static pressure (mmca)																									
	40		50		60		70		80		90		100		110		120		130		140		150		160	
	rpm	bhp	rpm	bhp	rpm	bhp	rpm	bhp	rpm	bhp	rpm	bhp	rpm	bhp	rpm	bhp	rpm	bhp	rpm	bhp	rpm	bhp	rpm	bhp	rpm	bhp
4400	1503	0.93	1626	1.16	1749	1.40	1872	1.67	1997	1.96	2125	2.28	2257	2.63	2395	3.02	2538	3.45	—	—	—	—	—	—	—	—
4800	1552	1.04	1667	1.27	1780	1.51	1892	1.78	2004	2.06	2118	2.37	2234	2.70	2353	3.06	2475	3.45	2601	3.88	2731	4.34	2866	4.85	—	—
5200	1606	1.15	1714	1.39	1820	1.64	1924	1.91	2027	2.20	2131	2.50	2235	2.82	2341	3.17	2449	3.54	2559	3.93	2672	4.35	2787	4.81	2906	5.30
5600	1663	1.28	1766	1.53	1866	1.79	1964	2.06	2060	2.35	2156	2.66	2253	2.98	2349	3.32	2447	3.67	2545	4.05	2646	4.45	2748	4.88	2852	5.33
6000	1722	1.43	1822	1.68	1917	1.95	2010	2.24	2101	2.53	2191	2.84	2281	3.16	2370	3.49	2460	3.85	2551	4.22	2642	4.61	2734	5.01	2828	5.44
6400	1783	1.58	1879	1.85	1971	2.13	2060	2.42	2147	2.72	2232	3.04	2317	3.36	2401	3.70	2485	4.05	2569	4.42	2654	4.80	2739	5.20	2824	5.62
6800	1846	1.76	1939	2.04	2028	2.33	2114	2.63	2197	2.94	2279	3.26	2359	3.59	2439	3.93	2518	4.29	2597	4.66	2676	5.04	2756	5.43	2835	5.84
7200	1910	1.94	2001	2.24	2087	2.54	2170	2.85	2250	3.17	2329	3.50	2406	3.83	2482	4.18	2557	4.54	2633	4.92	2707	5.30	2782	5.70	2857	6.11
7600	1975	2.15	2063	2.45	2147	2.76	2228	3.09	2306	3.42	2382	3.75	2456	4.10	2529	4.46	2602	4.83	2673	5.20	2744	5.59	2815	5.99	2886	6.40
8000	2041	2.37	2127	2.69	2209	3.01	2288	3.34	2363	3.68	2437	4.03	2509	4.39	2580	4.75	2649	5.13	2718	5.51	2786	5.91	2854	6.31	—	—

Tab. VII-23 - Fan Performance - Solution Plus 12 - Backward-Curved

Air flow (m³/h)	Total static pressure (mmca)																									
	40		50		60		70		80		90		100		110		120		130		140		150		160	
	rpm	bhp	rpm	bhp	rpm	bhp	rpm	bhp	rpm	bhp	rpm	bhp	rpm	bhp	rpm	bhp	rpm	bhp	rpm	bhp	rpm	bhp	rpm	bhp	rpm	bhp
5500	1923	1.36	2068	1.66	2206	2.00	2340	2.32	2471	2.68	2601	3.04	2730	3.40	2859	3.80	2988	4.20	3119	4.60	—	—	—	—	—	—
6000	1991	1.50	2131	1.84	2262	2.18	2389	2.54	2512	2.90	2633	3.28	2753	3.66	2871	4.06	2989	4.46	3108	4.88	3227	5.32	3346	5.76	—	—
6500	2063	1.68	2198	2.02	2325	2.40	2446	2.76	2563	3.14	2678	3.54	2790	3.94	2901	4.34	3011	4.76	3120	5.20	3230	5.64	3339	6.10	3448	6.56
7000	2136	1.86	2268	2.22	2391	2.62	2508	3.00	2621	3.40	2731	3.82	2838	4.22	2943	4.66	3046	5.10	3149	5.54	3251	6.00	3353	6.46	3454	6.94
7500	2211	2.04	2340	2.44	2460	2.84	2574	3.26	2684	3.68	2789	4.10	2892	4.54	2993	4.98	3092	5.44	3189	5.90	3286	6.36	3381	6.84	3477	7.34
8000	2287	2.26	2414	2.68	2532	3.10	2643	3.52	2750	3.96	2852	4.42	2952	4.88	3049	5.34	3144	5.80	3237	6.28	3330	6.76	3421	7.26	3511	7.76
8500	2365	2.48	2490	2.92	2605	3.36	2715	3.82	2819	4.28	2919	4.74	3015	5.22	3109	5.70	3201	6.20	3292	6.68	3380	7.18	3468	7.70	—	—
9000	2443	2.72	2566	3.18	2680	3.66	2787	4.12	2890	4.60	2987	5.10	3082	5.58	3174	6.08	3263	6.60	3351	7.12	3437	7.64	3521	8.16	—	—
9500	2521	2.98	2643	3.46	2756	3.96	2862	4.46	2962	4.96	3058	5.46	3151	5.98	3241	6.50	3328	7.02	3413	7.56	3497	8.10	—	—	—	—
10000	2601	3.26	2721	3.76	2833	4.28	2937	4.80	3036	5.32	3131	5.86	3222	6.38	3310	6.92	3395	7.48	3479	8.02	—	—	—	—	—	—

Tab. VII-24 - Transmission Options - Solution Plus 10 and 12 - Backward-Curved

TRANSM. OPTION	UNIT MODEL	DISCH. TYPE	MOTOR	RPM MOTOR	VENT	MIN. RPM	MAX. RPM	Φ MOTOR	Φ VENT.						
A	10	VERT.	3	3370	RLD355L	1423	1810	142	296						
B		HOR.													
C		FLOOR													
D		VERT.													
E		HOR.													
F		FLOOR													
G		VERT.	5	3500		2255	2868	142	194						
H		HOR.													
Y		FLOOR													
J		VERT.								7,5	3495	2585	3288	142	169
K		HOR.													
L		FLOOR													
A	VERT.	12	3	3370	RLD280Q	1923	2446	142	219						
B	HOR.														
C	FLOOR														
D	VERT.														
E	HOR.														
F	FLOOR														
G	VERT.		5	3500		2588	3292	142	169						
H	HOR.														
Y	FLOOR														
J	VERT.									7,5	3495	3055	3886	142	143
K	HOR.														
L	FLOOR														

Note:

- (1) Total static pressure in fan performance tables is at standard density. Standard density is based on air density at 21°C and a barometric pressure of 760 mmHg. This total pressure is the external static pressure required to the fan under operating condition, and shall include the pressure drop sums occurring in the components placed along the air flow and the typical drops in the duct that takes the expelled air through the fan.
- (2) Heat produced by fan motor (MBh) = 3.15 x BHP

Fan Performance and Transmission Option

(Backward-Curved)

Tab. VII-25 - Fan Performance - Solution Plus 15 - Backward-Curved

Air flow (m ³ /h)	Total static pressure (mmca)																									
	40		50		60		70		80		90		100		110		120		130		140		150		160	
	rpm	bhp	rpm	bhp	rpm	bhp	rpm	bhp	rpm	bhp	rpm	bhp	rpm	bhp	rpm	bhp	rpm	bhp	rpm	bhp	rpm	bhp	rpm	bhp	rpm	bhp
6000	—	—	1803	1.62	1970	2.02	2141	2.46	2321	2.98	2510	3.56	—	—	—	—	—	—	—	—	—	—	—	—	—	—
6600	—	—	1828	1.76	1976	2.14	2127	2.58	2281	3.04	2441	3.58	2607	4.16	2780	4.80	—	—	—	—	—	—	—	—	—	—
7200	—	—	1865	1.92	2001	2.30	2137	2.72	2274	3.18	2414	3.68	2558	4.22	2706	4.82	2859	5.46	3018	6.18	3184	6.96	—	—	—	—
7800	1780	0.86	1910	2.08	2037	2.48	2162	2.90	2288	3.36	2414	3.84	2543	4.36	2673	4.92	2807	5.54	2944	6.18	3085	6.88	3231	7.64	3383	8.46
8400	1837	1.90	1961	2.28	2081	2.70	2198	3.12	2315	3.58	2431	4.06	2548	4.58	2667	5.12	2787	5.70	2909	6.30	3033	6.96	3161	7.66	3291	8.42
9000	1897	2.10	2016	2.50	2130	2.92	2242	3.36	2351	3.82	2460	4.30	2569	4.82	2678	5.36	2788	5.92	2899	6.52	3011	7.14	3125	7.82	3241	8.52
9600	1960	2.32	2075	2.74	2184	3.18	2291	3.62	2395	4.10	2498	4.58	2600	5.10	2702	5.64	2804	6.20	2906	6.78	3010	7.40	3114	8.04	3219	8.72
10200	2024	2.58	2136	3.00	2241	3.46	2344	3.92	2444	4.40	2542	4.90	2639	5.42	2735	5.96	2831	6.52	2927	7.10	3023	7.72	3119	8.36	3217	9.02
10800	2090	2.84	2198	3.28	2301	3.76	2400	4.22	2496	4.72	2590	5.24	2683	5.76	2774	6.32	2865	6.88	2956	7.46	3047	8.08	3137	—	—	—
11400	2157	3.14	2263	3.60	2363	4.08	2459	4.56	2552	5.08	2643	5.60	2732	6.14	2820	6.70	2906	7.28	2993	7.86	3079	8.48	3165	—	—	—
12000	2225	3.46	2329	3.92	2426	4.42	2520	4.94	2610	5.46	2698	6.00	2784	6.56	2869	7.12	2952	7.70	3035	8.30	3117	8.92	3199	—	—	—

Tab. VII-26 - Fan Performance - Solution Plus 20 - Backward-Curved

Air flow (m ³ /h)	Total static pressure (mmca)																									
	40		50		60		70		80		90		100		110		120		130		140		150		160	
	rpm	bhp	rpm	bhp	rpm	bhp	rpm	bhp	rpm	bhp	rpm	bhp	rpm	bhp	rpm	bhp	rpm	bhp	rpm	bhp	rpm	bhp	rpm	bhp	rpm	bhp
9000	—	—	1636	2.36	1755	2.86	1875	3.38	1997	3.96	2121	4.60	2249	5.28	2380	6.04	2517	6.88	2660	7.80	—	—	—	—	—	—
9800	—	—	1678	2.60	1789	3.08	1899	3.62	2009	4.18	2120	4.80	2233	5.46	2348	6.16	2466	6.94	2587	7.76	2712	8.66	2842	9.64	2976	10.72
10600	1620	2.36	1727	2.84	1831	3.36	1933	3.90	2035	4.46	2136	5.08	2238	5.72	2342	6.40	2447	7.14	2553	7.92	2663	8.74	2774	9.64	2889	10.58
11400	1677	2.64	1780	3.14	1879	3.66	1975	4.22	2070	4.80	2164	5.40	2259	6.04	2353	6.72	2449	7.42	2545	8.18	2643	8.98	2742	9.82	2844	10.70
12200	1737	2.92	1836	3.46	1930	4.00	2022	4.56	2112	5.16	2201	5.76	2289	6.42	2377	7.08	2466	7.80	2554	8.54	2644	9.30	2734	10.12	2826	10.96
13000	1799	3.26	1894	3.80	1985	4.36	2073	4.94	2159	5.56	2244	6.18	2327	6.84	2410	7.52	2493	8.22	2576	8.96	2659	9.72	2742	10.52	2826	11.34
13800	1862	3.60	1954	4.16	2043	4.76	2127	5.36	2210	5.98	2291	6.62	2370	7.30	2449	7.98	2528	8.70	2606	9.44	2683	10.20	2761	11.00	2840	11.82
14600	1926	3.98	2016	4.58	2102	5.18	2184	5.82	2264	6.46	2342	7.12	2418	7.80	2493	8.50	2568	9.22	2642	9.98	2716	10.74	2790	11.54	2863	12.36
15400	1991	4.40	2079	5.02	2163	5.64	2243	6.30	2320	6.96	2395	7.64	2469	8.34	2542	9.06	2613	9.80	2684	10.56	2754	11.34	2825	12.14	2894	12.96
16200	2057	4.86	2143	5.50	2225	6.14	2303	6.82	2378	7.50	2451	8.20	2523	8.92	2593	9.66	2662	10.42	2730	11.18	2798	11.98	2865	12.78	—	—
17000	2124	5.36	2208	6.00	2288	6.68	2364	7.38	2438	8.08	2509	8.82	2578	9.56	2646	10.30	2713	11.08	2779	11.86	2844	12.68	2909	13.50	—	—

Tab. VII-27 - Transmission Options - Solution Plus 15 and 20- Backward-Curved

TRANS. OPTION	UNIT MODEL	DISCH. TYPE	MOTOR	RPM MOTOR	VENT	MIN. RPM	MAX. RPM	Φ MOTOR	Φ VENT.
A	15	VERT.	5	3500	RLD315Q	1785	2271	142	245
B		HOR.							
C		FLOOR							
D		VERT.							
E		HOR.							
F		FLOOR							
G		VERT.	7.5	3495					
H		HOR.							
Y		FLOOR							
J		VERT.							
K		HOR.							
L		FLOOR							
A	20	VERT.	5	3500	RLD355Q	1478	1880	142	296
B		HOR.							
C		FLOOR							
D		VERT.							
E		HOR.							
F		FLOOR							
G		VERT.	7.5	3495					
H		HOR.							
Y		FLOOR							
J		VERT.							
K		HOR.							
L		FLOOR							
M	VERT.	10	3515						
N	HOR.								
P	FLOOR								
	VERT.			15	3520				
	HOR.								
	FLOOR								
	VERT.								
	HOR.								
	FLOOR								

Note:

- (1) Total static pressure in fan performance tables is at standard density. Standard density is based on air density at 21°C and a barometric pressure of 760 mmHg. This total pressure is the external static pressure required to the fan under operating condition, and shall include the pressure drop sums occurring in the components placed along the air flow and the typical drops in the duct that takes the expelled air through the fan.
- (2) Heat produced by fan motor (MBH) = 3.15 x BHP



Fan Performance and Transmission Option

(Backward-Curved)

Tab. VII-28 - Fan Performance - Solution Plus 25 - Backward-Curved

Air flow (m³/h)	Total static pressure (mmca)																										
	40		50		60		70		80		90		100		110		120		130		140		150		160		
	rpm	bhp	rpm	bhp	rpm	bhp	rpm	bhp	rpm	bhp	rpm	bhp	rpm	bhp	rpm	bhp	rpm	bhp	rpm	bhp	rpm	bhp	rpm	bhp	rpm	bhp	rpm
12000	----	----	1436	2,98	1544	3,58	1647	4,18	1745	4,82	1840	5,44	1930	6,10	2017	6,74	2102	7,40	2185	8,08	2265	8,76	----	----	----	----	----
13000	1355	2,66	1465	3,26	1569	3,88	1669	4,52	1764	5,18	1856	5,86	1944	6,54	2030	7,22	2113	7,94	2193	8,64	2271	9,36	2347	10,08	2422	10,80	----
14000	1391	2,92	1497	3,54	1598	4,20	1694	4,88	1787	5,56	1876	6,28	1962	7,00	2045	7,72	2126	8,46	2205	9,22	2281	9,96	2356	10,74	----	----	----
15000	1430	3,20	1532	3,86	1629	4,54	1722	5,24	1812	5,96	1899	6,70	1983	7,46	2064	8,22	2143	9,00	2220	9,80	2295	10,58	2368	11,40	----	----	----
16000	1471	3,50	1569	4,18	1662	4,90	1753	5,64	1840	6,40	1924	7,16	2006	7,96	2085	8,76	2163	9,56	2238	10,38	2311	11,22	2383	12,06	----	----	----
17000	1513	3,82	1608	4,54	1699	5,28	1736	6,06	1870	6,84	1952	7,64	2032	8,46	2109	9,30	2185	10,14	2258	11,00	2330	11,86	2400	12,74	----	----	----
18000	1557	4,16	1649	4,92	1737	5,70	1821	6,50	1903	7,32	1983	8,14	2060	9,00	2136	9,86	2209	10,74	2281	11,62	2352	12,54	2420	13,44	----	----	----
19000	1603	4,54	1692	5,34	1777	6,14	1859	6,96	1938	7,82	2016	8,68	2091	9,56	2165	10,46	2236	11,36	2307	12,28	2375	13,22	----	----	----	----	----
20000	1650	4,94	1736	5,76	1818	6,60	1898	7,46	1975	8,34	2050	9,24	2124	10,14	2195	11,08	2265	12,02	2334	12,96	2401	13,94	----	----	----	----	----
21000	1697	5,38	1781	6,22	1861	7,10	1939	8,00	2014	8,90	2087	9,82	2158	10,76	2228	11,72	2297	12,70	2364	13,68	----	----	----	----	----	----	----

Tab. VII-29 - Fan Performance - Solution Plus 30 - Backward-Curved

Air flow (m³/h)	Total static pressure (mmca)																										
	40		50		60		70		80		90		100		110		120		130		140		150		160		
	rpm	bhp	rpm	bhp	rpm	bhp	rpm	bhp	rpm	bhp	rpm	bhp	rpm	bhp	rpm	bhp	rpm	bhp	rpm	bhp	rpm	bhp	rpm	bhp	rpm	bhp	rpm
15000	----	----	1273	3,72	1370	4,46	1461	5,22	1549	6,00	1633	6,80	1714	7,60	1792	8,42	1868	9,24	1941	10,08	2013	10,92	----	----	----	----	----
16000	----	----	1293	3,98	1387	4,76	1476	5,56	1562	6,36	1644	7,20	1723	8,04	1800	8,90	1874	9,76	1946	10,64	2016	11,52	2085	12,42	2152	13,32	----
17000	----	----	1314	4,26	1405	5,06	1493	5,90	1577	6,74	1657	7,60	1735	8,48	1810	9,38	1883	10,28	1953	11,20	2022	12,14	2089	13,06	2155	14,00	----
18000	----	----	1337	4,56	1426	5,40	1511	6,26	1593	7,14	1672	8,04	1748	8,94	1822	9,88	1893	10,82	1963	11,78	2030	12,74	2096	13,72	2161	14,70	----
19000	1271	4,02	1362	4,86	1448	5,74	1531	6,62	1611	7,54	1688	8,46	1763	9,42	1835	10,38	1905	11,36	1973	12,36	2040	13,36	2105	14,38	2168	15,40	----
20000	1300	4,32	1388	5,20	1472	6,10	1552	7,02	1630	7,96	1706	8,92	1779	9,90	1850	10,90	1919	11,92	1986	12,94	2051	13,98	2115	15,04	2178	16,10	----
21000	1329	4,64	1415	5,54	1496	6,46	1575	7,42	1651	8,40	1725	9,40	1796	10,40	1866	11,44	1934	12,48	2000	13,56	2064	14,62	2127	15,72	2186	16,82	----
22000	1360	4,98	1443	5,90	1523	6,86	1599	7,84	1673	8,86	1746	9,88	1816	10,92	1884	12,00	1950	13,08	2015	14,18	2078	15,28	2140	16,40	2201	17,54	----
23000	1391	5,34	1472	6,30	1550	7,28	1625	8,30	1697	9,34	1767	10,40	1836	11,46	1903	12,56	1968	13,68	2032	14,80	2094	15,96	2155	17,12	2214	18,28	----
24000	1423	5,70	1502	6,70	1578	7,72	1651	8,76	1722	9,84	1791	10,92	1858	12,02	1923	13,16	1987	14,30	2049	15,46	2111	16,64	2170	17,84	----	----	----
25000	1456	6,10	1533	7,14	1607	8,18	1678	9,26	1747	10,36	1815	11,48	1880	12,62	1945	13,78	2007	14,94	2068	16,14	2129	17,36	2187	18,58	----	----	----

Tab. VII-30 - Transmission Options - Solution Plus 25 and 30 - Backward-Curved

TRANSM. OPTION	UNIT MODEL	DISCH. TYPE	MOTOR	RPM MOTOR	VENT	MIN. RPM	MAX. RPM	Φ MOTOR	Φ VENT.
A	25	VERT.	5	3500	RLD400Q	1264	1608	142	346
B		HOR.							
C		FLOOR							
D		VERT.							
E		HOR.							
F		FLOOR							
G		VERT.	7,5	3495					
H		HOR.							
Y		FLOOR							
J		VERT.							
K		HOR.							
L		FLOOR							
M		VERT.	10	3515					
N		HOR.							
P		FLOOR							
Q		VERT.							
R	HOR.								
S	FLOOR								
A	30	VERT.	7,5	3495	RLD450Q	1271	1617	142	346
B		HOR.							
C		FLOOR							
D		VERT.							
E		HOR.							
F		FLOOR							
G		VERT.	10	3515					
H		HOR.							
Y		FLOOR							
J		VERT.							
K		HOR.							
L		FLOOR							
M		VERT.	15	3520					
N		HOR.							
P		FLOOR							
N		VERT.				20	3530		
N	HOR.								
P	FLOOR								
P	FLOOR								

Note:
 (1) Total static pressure in fan performance tables is at standard density. Standard density is based on air density at 21°C and a barometric pressure of 760 mmHg. This total pressure is the external static pressure required to the fan under operating condition, and shall include the pressure drop sums occurring in the components placed along the air flow and the typical drops in the duct that takes the expelled air through the fan.
 (2) Heat produced by fan motor (MBh) = 3.15 x BHP

Fan Performance and Transmission Option

(Backward-
Curved)

Tab. VII-31 - Fan Performance - Solution Plus 35 - Backward-Curved

Air flow (m ³ /h)	Total static pressure (mmca)																										
	40		50		60		70		80		90		100		110		120		130		140		150		160		
	rpm	bhp	rpm	bhp	rpm	bhp	rpm	bhp	rpm	bhp	rpm	bhp	rpm	bhp	rpm	bhp	rpm	bhp	rpm	bhp	rpm	bhp	rpm	bhp	rpm	bhp	rpm
17500	1231	3,62	1325	4,40	1415	5,22	1502	6,08	1584	6,94	1664	7,82	1741	8,72	1816	9,64	1888	10,56	1958	11,50	2026	12,44	2092	13,40	2157	14,36	
19000	1271	4,02	1362	4,86	1448	5,74	1531	6,62	1611	7,54	1688	8,46	1763	9,42	1835	10,38	1905	11,36	1973	12,36	2040	13,36	2105	14,38	2168	15,40	
20500	1315	4,48	1401	5,36	1484	6,28	1564	7,22	1641	8,18	1715	9,16	1787	10,16	1858	11,18	1926	12,20	1993	13,24	2058	14,30	2121	15,38	2183	16,46	
22000	1360	4,98	1443	5,90	1523	6,86	1599	7,84	1673	8,86	1746	9,88	1816	10,92	1884	12,00	1950	13,08	2015	14,18	2078	15,28	2140	16,40	2201	17,54	
23500	1407	5,52	1487	6,50	1564	7,50	1638	8,52	1709	9,58	1779	10,66	1847	11,74	1913	12,86	1977	13,98	2040	15,14	2102	16,30	2162	17,48	2222	18,66	
25000	1456	6,10	1533	7,14	1607	8,18	1678	9,26	1747	10,36	1815	11,48	1880	12,62	1945	13,78	2007	14,94	2068	16,14	2129	17,36	2187	18,58	----	----	
26500	15C6	6,74	1581	7,82	1652	8,92	1721	10,04	1788	11,18	1853	12,34	1917	13,54	1979	14,74	2040	15,96	2099	17,20	2158	18,46	2215	19,72	----	----	
28000	1557	7,44	1629	8,56	1699	9,70	1765	10,88	1830	12,06	1893	13,28	1955	14,50	2015	15,76	2074	17,02	2132	18,30	2189	19,62	----	----	----	----	
29500	1609	8,18	1679	9,34	1747	10,54	1812	11,76	1874	13,00	1936	14,26	1995	15,54	2054	16,84	2111	18,14	2168	19,48	2223	20,82	----	----	----	----	
31000	1661	8,98	1730	10,20	1796	11,44	1859	12,72	1920	14,00	1979	15,30	2038	16,62	2095	17,98	2150	19,34	2205	20,70	----	----	----	----	----	----	

Tab. VII-32 - Transmission Options - Solution Plus 35 - Backward-Curved

TRANSM. OPTION	UNIT MODEL	DISCH. TYPE	MOTOR	RPM MOTOR	VENT	MIN. RPM	MAX. RPM	Φ MOTOR	Φ VENT.
A	35	VERT.	7.5	3495	RLD450Q	1262	1606	14	346
B		HOR.							
C		FLOOR							
D		VERT.							
E		HOR.	10	3515		1484	1888	142	296
F		FLOOR							
G		VERT.							
H		HOR.							
Y		FLOOR	15	3520		1621	2062	142	271
J		VERT.							
K		HOR.							
L		FLOOR							
M		VERT.	20	3530		2091	-	161	271
N		HOR.							
P		FLOOR							

Note:
 (1) Total static pressure in fan performance tables is at standard density. Standard density is based on air density at 21°C and a barometric pressure of 760 mmHg. This total pressure is the external static pressure required to the fan under operating condition, and shall include the pressure drop sums occurring in the components placed along the air flow and the typical drops in the duct that takes the expelled air through the fan.
 (2) Heat produced by fan motor (MBh) = 3.15 x BHP



Fan Performance and Transmission Option

(Backward-Curved)

Tab. VII-33 - Fan Performance - Solution Plus 40 - Backward-Curved

Air flow (m³/h)	Total static pressure (mmca)																									
	40		50		60		70		80		90		100		110		120		130		140		150		160	
	rpm	bhp	rpm	bhp	rpm	bhp	rpm	bhp	rpm	bhp	rpm	bhp	rpm	bhp	rpm	bhp	rpm	bhp	rpm	bhp	rpm	bhp	rpm	bhp	rpm	bhp
20000	1078	4,04	1167	4,96	1251	5,92	1331	6,92	1408	7,92	1482	8,96	1553	10,00	1622	11,06	1688	12,14	1753	13,24	1815	14,34	1877	15,24	1937	16,56
21500	1106	4,42	1191	5,40	1272	6,40	1350	7,44	1425	8,50	1497	9,58	1566	10,68	1633	11,80	1698	12,94	1761	14,08	1823	15,24	1883	16,42	1941	17,60
23000	1135	4,82	1217	5,84	1296	6,90	1371	7,98	1444	9,10	1514	10,22	1581	11,38	1647	12,56	1710	13,74	1772	14,94	1833	16,16	1891	17,40	1949	18,64
24500	1166	5,26	1245	6,34	1321	7,42	1394	8,56	1464	9,72	1533	10,90	1599	12,10	1663	13,32	1725	14,56	1785	15,82	1845	17,10	1902	18,38	1958	19,68
26000	1198	5,74	1275	6,84	1348	8,00	1419	9,16	1487	10,36	1553	11,60	1618	12,84	1680	14,12	1741	15,42	1801	16,72	1858	18,06	19,15	19,40	1970	20,76
27500	1232	6,24	1306	7,40	1377	8,60	1445	9,82	1512	11,06	1576	12,34	1639	13,64	1700	14,96	1759	16,30	1817	17,66	1874	19,04	1930	20,44	1984	21,84
29000	1266	6,78	1338	8,00	1407	9,22	1474	10,50	1538	11,78	1601	13,10	1662	14,46	1721	15,82	1779	17,22	1836	18,62	1892	20,06	1946	21,50	1999	22,96
30500	1302	7,36	1371	8,62	1438	9,90	1503	11,22	1566	12,56	1627	13,92	1686	15,32	1744	16,72	1801	18,16	1856	19,62	1911	21,10	1964	22,60	2016	24,10
32000	1338	7,98	1406	9,28	1471	10,62	1534	11,98	1595	13,36	1654	14,78	1712	16,22	1769	17,68	1824	19,16	1878	20,66	1931	22,18	1984	23,72		
33500	1375	8,64	1441	10,00	1504	11,38	1566	12,78	1625	14,22	1683	15,68	1739	17,16	1795	18,66	1849	20,18	1902	21,74	1954	23,32	2005	24,90		
35000	1412	9,36	1477	10,76	1539	12,18	1598	13,64	1656	15,12	1713	16,62	1768	18,14	1822	19,70	1875	21,26	1926	22,86	1977	24,48				

Tab. VII-34 - Fan Performance - Solution Plus 50 - Backward-Curved

Air flow (m³/h)	Total static pressure (mmca)																									
	40		50		60		70		80		90		100		110		120		130		140		150		160	
	rpm	bhp	rpm	bhp	rpm	bhp	rpm	bhp	rpm	bhp	rpm	bhp	rpm	bhp	rpm	bhp	rpm	bhp	rpm	bhp	rpm	bhp	rpm	bhp	rpm	bhp
25000	1176	5,42	1255	6,50	1330	7,62	1402	8,76	1472	9,92	1539	11,12	1605	12,34	1668	13,58	1730	14,84	1790	16,12	1849	17,42	1906	18,72	1962	20,04
26500	1209	5,90	1285	7,02	1358	8,18	1428	9,38	1495	10,60	1561	11,84	1625	13,10	1687	14,40	1747	15,70	1806	17,04	1863	18,38	1920	19,74	1975	21,12
28000	1243	6,42	1316	7,60	1387	8,80	1455	10,04	1520	11,30	1584	12,58	1646	13,90	1707	15,24	1766	16,30	1823	17,98	1880	19,38	1935	20,78	1989	22,22
29500	1278	6,98	1349	8,20	1417	9,44	1483	10,72	1547	12,04	1609	13,38	1670	14,74	1729	16,12	1786	17,52	1843	18,96	1898	20,40	1952	21,86	2005	13,34
31000	1314	7,56	1383	8,84	1449	10,14	1513	11,46	1575	12,82	1636	14,20	1695	15,60	1752	17,04	1808	18,48	1864	19,96	1917	21,46	1970	22,96	2022	24,50
32500	1350	8,20	1417	9,52	1482	10,86	1544	12,24	1605	13,64	1664	15,06	1721	16,52	1777	18,00	1832	19,50	1886	21,02	1939	22,56	1990	24,12	----	----
34000	1387	8,88	1453	10,24	1516	11,64	1576	13,06	1635	14,50	1693	15,98	1749	17,48	1803	19,00	1857	20,54	1910	22,12	1961	23,70	----	----	----	----
35500	1425	9,60	1489	11,02	1550	12,46	1610	13,92	1667	15,42	1723	16,94	1778	18,48	1831	20,06	1883	21,64	1935	23,26	1985	24,88	----	----	----	----
37000	1463	10,36	1526	11,82	1586	13,32	1644	14,84	1700	16,38	1754	17,94	1808	19,54	1860	21,14	1911	22,78	1961	24,44	----	----	----	----	----	----
38500	1501	11,18	1563	12,68	1622	14,24	1678	15,80	1733	17,38	1736	19,00	1839	20,64	1890	22,30	1940	23,98	----	----	----	----	----	----	----	----
40000	1539	12,04	1601	13,60	1658	15,20	1714	16,80	1767	18,44	1819	20,10	1870	21,80	1920	23,50	----	----	----	----	----	----	----	----	----	----

Tab. VII-35 - Transmission Options - Solution Plus 40 and 50 - Backward-Curved

TRANS. OPTION	UNIT MODEL	DISCH. TYPE	MOTOR	RPM MOTOR	VENT	MIN. RPM	MAX. RPM	Φ MOTOR	Φ VENT.						
A	40	VERT.	10	3515	RLD500Q	996	1267	142	441						
B		HOR.													
C		FLOOR													
D		VERT.													
E		HOR.													
F		FLOOR													
G		VERT.	15	3520		1984	-	181	321						
H		HOR.													
Y		FLOOR													
J		VERT.								20	3530	1990	-	181	321
K		HOR.													
L		FLOOR													
M		VERT.	25	3530		2034	-	200	347						
N		HOR.													
P		FLOOR													
Q		VERT.								50	10	3515	RLD500Q	996	1267
R	HOR.														
S	FLOOR														
A	VERT.	15	3520	1984	-	181	321								
B	HOR.														
C	FLOOR														
D	VERT.							20	3530		1990	-		181	321
E	HOR.														
F	FLOOR														
G	VERT.	25	3530	2034	-	200	347								
H	HOR.														
Y	FLOOR														
J	VERT.							10	3515		1984	-		181	321
K	HOR.														
L	FLOOR														
M	VERT.	15	3520	1990	-	181	321								
N	HOR.														
P	FLOOR														
Q	VERT.							20	3530	1990	-	181	321		
R	HOR.														
S	FLOOR														

Note:

- (1) Total static pressure in fan performance tables is at standard density. Standard density is based on air density at 21°C and a barometric pressure of 760 mmHg. This total pressure is the external static pressure required to the fan under operating condition, and shall include the pressure drop sums occurring in the components placed along the air flow and the typical drops in the duct that takes the expelled air through the fan.
- (2) Heat produced by fan motor (MBh) = 3.15 x BHP

VIII - Electrical Characteristics Motor and Compressor

60 Hz

Tab. VIII-01-Pole Motor Electrical Characteristics - 60 Hz - Forward-Curved Fans

Motor Capacities	0,5	0,75	1	1,5	2	3	4	5	6	7,5	10	12,5	15	20	25	30	40	
N° Poles	4	4	4	4	4	4	4	4	4	4	4	4	4	4	4	4	4	
Protection level	IP21	IP21	IP21	IP21	IP21	IP21	IP55	IP55	IP55	IP55	IP55	IP55	IP55	IP55	IP55	IP55	IP55	
Nominal RPM	1730	1735	1720	1710	1710	1740	1715	1735	1740	1740	1760	1760	1760	1765	1765	1765	1770	
Nom. Power (kW)	0,38	0,60	0,81	1,18	1,50	2,12	2,40	2,96	3,60	4,40	6,00	7,36	8,80	12,00	14,80	17,60	24,00	
Máx. Power (kW)	0,48	0,75	1,01	1,47	1,88	2,65	3,00	3,70	4,50	5,50	7,50	9,20	11,00	15,00	18,50	22,00	30,00	
220 V	RLA (A)	1,54	2,26	2,84	3,85	5,18	7,94	8,88	10,96	13,28	16,16	20,64	25,12	29,76	42,08	51,68	59,20	79,36
	FLA (A)	1,92	2,82	3,55	4,81	6,48	9,93	11,10	13,70	16,60	20,20	25,80	31,40	37,20	52,60	64,60	74,00	99,20
	LRA (A)	9,62	15,00	19,20	27,42	37,58	77,45	71,04	109,60	102,92	127,26	203,82	251,20	305,04	357,68	439,28	473,60	615,04
380 V	RLA (A)	0,89	1,30	1,64	2,22	2,99	4,58	5,12	6,32	7,66	9,32	11,91	14,49	17,17	24,28	29,82	34,16	45,79
	FLA (A)	1,11	1,63	2,05	2,78	3,74	5,73	6,40	7,90	9,58	11,66	14,89	18,12	21,46	30,35	37,27	42,70	57,24
	LRA (A)	5,55	8,66	11,08	15,82	21,69	44,69	40,99	63,24	59,38	73,43	117,60	144,94	176,01	206,38	253,46	273,27	354,88
440 V	RLA (A)	0,77	1,13	1,42	1,92	2,59	3,97	4,44	5,48	6,64	8,08	10,32	12,56	14,88	21,04	25,84	29,60	39,68
	FLA (A)	0,96	1,41	1,78	2,41	3,24	4,97	5,55	6,85	8,30	10,10	12,90	15,70	18,60	26,30	32,30	37,00	49,60
	LRA (A)	4,81	7,50	9,60	13,71	18,79	38,73	35,52	54,80	51,46	63,63	101,91	125,60	152,52	178,84	219,64	236,80	307,52
460 V	RLA (A)	0,73	1,08	1,36	1,84	2,48	3,80	4,25	5,24	6,35	7,73	9,87	12,01	14,23	20,13	24,72	28,31	37,95
	FLA (A)	0,92	1,35	1,70	2,30	3,10	4,75	5,31	6,55	7,94	9,66	12,34	15,02	17,79	25,16	30,90	35,39	47,44
	LRA (A)	4,60	7,17	9,18	13,11	17,97	37,04	33,98	52,42	49,22	60,86	97,48	120,14	145,89	171,06	210,09	226,50	294,15

Tab. VIII-02-Pole Motor Electrical Characteristics - 60 Hz - Backward-Curved Fans

Motor Capacities	0,5	0,75	1	1,5	2	3	4	5	6	7,5	10	12,5	15	20	25	30	40	
N° Poles	2	2	2	2	2	2	2	2	2	2	2	2	2	2	2	2	2	
Protection level	IP21	IP21	IP21	IP21	IP21	IP21	IP55	IP55	IP55	IP55	IP55	IP55	IP55	IP55	IP55	IP55	IP55	
Nominal RPM	3450	3455	3465	3440	3450	3400	3450	3500	3480	3495	3515	3515	3520	3530	3530	3535	3550	
Nom. Power (kW)	0,42	0,62	0,81	1,10	1,47	2,22	2,40	2,96	3,60	4,40	6,00	7,36	8,80	12,00	14,80	17,60	24,00	
Máx. Power (kW)	0,53	0,77	1,01	1,37	1,84	2,78	3,00	3,70	4,50	5,50	7,50	9,20	11,00	15,00	18,50	22,00	30,00	
220 V	RLA (A)	1,38	2,00	2,62	3,27	4,50	6,48	8,56	10,24	12,08	15,04	20,00	24,00	28,96	39,84	48,80	57,76	79,20
	FLA (A)	1,73	2,50	3,27	4,09	5,62	8,10	10,70	12,80	15,10	18,80	25,00	30,00	36,20	49,80	61,00	72,20	99,00
	LRA (A)	13,84	14,25	21,26	34,77	45,52	53,46	79,18	112,64	108,72	156,04	180,00	225,00	300,46	328,68	414,80	541,50	633,60
380 V	RLA (A)	0,80	1,15	1,51	1,89	2,59	3,74	4,94	5,91	6,97	8,68	11,54	13,85	16,71	22,99	28,16	33,33	45,70
	FLA (A)	1,00	1,44	1,89	2,36	3,24	4,67	6,17	7,39	8,71	10,85	14,43	17,31	20,89	28,73	35,20	41,66	57,12
	LRA (A)	7,99	8,22	12,26	20,06	26,27	30,85	45,69	64,99	62,73	90,04	103,86	129,83	173,37	189,65	239,34	312,45	365,59
440 V	RLA (A)	0,69	1,00	1,31	1,64	2,25	3,24	4,28	5,12	6,04	7,52	10,00	12,00	14,48	19,92	24,40	28,88	39,60
	FLA (A)	0,87	1,25	1,64	2,05	2,81	4,05	5,35	6,40	7,55	9,40	12,50	15,00	18,10	24,90	30,50	36,10	49,50
	LRA (A)	6,92	7,13	10,63	17,38	22,76	26,73	39,59	56,32	54,36	78,02	90,00	112,50	150,23	164,34	207,40	270,75	316,80
460 V	RLA (A)	0,66	0,96	1,25	1,56	2,15	3,10	4,09	4,90	5,78	7,19	9,57	11,48	13,85	19,05	23,34	27,62	37,88
	FLA (A)	0,83	1,20	1,56	1,96	2,69	3,87	5,12	6,12	7,22	8,99	11,96	14,35	17,31	23,82	29,17	34,53	47,35
	LRA (A)	6,62	6,82	10,17	16,63	21,77	25,57	37,87	53,87	52,00	74,63	86,09	107,61	143,70	157,19	198,38	258,98	303,03

Tab. VIII-03 - Compressor Electrical Characteristics - 60 Hz

Nominal Capacity	Kw (Nominal)			Kw (Maximum)			RLA			FLA			LRA		
	220V / 380V / 440V	220V / 380V / 440V	220V / 380V / 440V	220	380	440	220	380	440	220	380	440	220	380	440
5	5,7	7,18		16,8	11,0	7,9	20,5	13,2	9,5	170,0	96,0	82,0			
7,5	8,57	10,83		26,2	16,3	13,2	31,6	19,7	15,9	203,0	124,0	98,0			
10	9,96	12,51		31,3	19,0	15,3	37,5	22,8	18,3	267,0	160,0	142,0			
12,5	12,94	16,22		38,8	23,8	19,0	46,8	28,8	22,9	304,0	168,0	147,0			
15	16,45	20,45		50,0	29,8	25,0	59,8	35,7	29,9	351,0	239,0	197,0			
20	22,56	28,18		74,6	40,9	31,2	86,5	49,5	38,6	485,0	260,0	215,0			
25	27,21	34,29		81,3	48,7	39,2	98,7	59,6	48,0	560,0	310,0	260,0			
1	2	5	8	9	10	11	12	13	14	15	16				

Tab. VIII-04 - Motors and Condensers Electrical Characteristics - TRAE (60 Hz)

Motor Power (cv)	One-Phase - IP21				RLA			FLA			LRA		
	N. Polos	rpm	kW		220	260	440	220	260	440	220	260	440
0,25	8	800	0,35		1,6	1,40	-	1,76	1,54	-	4,8	4,20	-
0,75	8	800	0,55		3,9	-	2	4,29	-	2,2	9,75	-	6
1	8	800	0,75		5,44	-	2,72	5,98	-	2,99	14,14	-	7,62

Notes:
 (1) RLA = Rated Load Amps (A)
 (2) FLA = Full Load Amps (A)
 (3) LRA = Locked Rotor Amps (A)

Electrical Characteristics

DXPA - TRAE
(60Hz)

Tab. VIII-05 - Electrical data Solution Plus 050 with TRAE

Compressor	Condenser Motor	Evaporator Motor	Total Cons. (kW)		Voltage (V)	Evap. Motor (cv)	Total Current		
			Nom.	Máx.			RLA	FLA	Partida
1 x 5 TR	1 x 0,25 CV	1 x 1 CV	6,51	8,11	220	1	21,44	25,81	176,93
						1,5	22,45	27,07	178,19
		1 x 1,5 CV	6,79	8,46	380	1	14,42	17,00	101,43
						1,5	15,00	17,73	102,16
		440	1	11,13	13,05	87,16			
			1,5	11,63	13,68	87,79			

Tab. VIII-06 - Electrical data Solution Plus 075 with TRAE

Compressor	Condenser Motor	Evaporator Motor	Total Cons. (kW)		Voltage (V)	Evap. Motor (cv)	Total Current		
			Nom.	Máx.			RLA	FLA	Partida
1 x 7,5 TR	1 x 0,75 CV	1 x 1,5 CV	10,00	12,48	220	1,5	34,39	40,71	220,71
						2	35,72	42,38	222,38
		1 x 2 CV	10,32	12,88	380	3	38,48	45,83	225,83
						1,5	22,84	26,74	139,68
		440	2	23,61	27,70	140,64			
			3	25,20	29,69	142,63			
1 x 3 CV	10,88	13,58	440	1,5	17,14	20,33	106,41		
				2	17,81	21,16	107,24		
3	19,19	22,89	108,97						

Tab. VIII-07 - Electrical data Solution Plus 100 (1 ckt) with TRAE

Compressor	Condenser Motor	Evaporator Motor	Total Cons. (kW)		Voltage (V)	Evap. Motor (cv)	Total Current		
			Nom.	Máx.			RLA	FLA	Partida
1 x 10 TR	1 x 1,0 CV	1 x 2 CV	11,91	14,76	220	2	41,36	48,89	287,68
						3	44,12	52,34	291,13
		1 x 3 CV	12,47	15,46	380	4	45,06	53,51	292,30
						2	26,88	31,41	177,94
		440	3	28,47	33,40	179,93			
			4	29,01	34,07	180,60			
1 x 4 CV	13,11	16,26	440	2	20,28	23,98	151,94		
				3	21,66	25,71	153,67		
4	22,13	26,29	154,25						

Notes:

- (1) RLA = Rated Load Amps(A);
- (2) FLA = Full Load Amps (A);
- (3) Cominal consumption as per ARI standard.;
- (4) Evaporator motor oa a 4-pole motor with Forward-Curved fan; for 2-pole motor (Backward-Curved);
- (5) Voltage variation: +/- 10%;
- (6) Electrical wiring should be sized using Full Load Amps (FLA) in the table above.

Electrical Characteristics

DXPA - TRAE
(60Hz)

Tab. VIII-08 - Electrical data Solution Plus 100 (2 ckt) with TRAE

Compressor	Condenser Motor	Evaporator Motor	Total Cons. (kW)		Voltage (V)	Evap. Motor (cv)	Total Current			
			Nom.	Máx.			RLA	FLA	Partida	
2 x 5 TR	1 x 1,0 CV	1 x 2 CV	13,41	16,61	220	2	43,70	52,32	201,85	
						3	46,46	55,77	205,30	
						4	47,40	56,94	206,47	
		1 x 3 CV	13,97	17,31		380	2	29,87	34,96	117,80
							3	31,46	36,95	119,79
							4	32,00	37,62	120,46
1 x 4 CV	14,61	18,11	440	2	20,83		24,60	97,12		
				3	22,21		26,33	98,85		
				4	22,68		26,91	99,43		

Tab. VIII-09 - Electrical data Solution Plus 125 (2 ckt) with TRAE075+TRAE050

Compressor	Condenser Motor	Evaporator Motor	Total Cons. (kW)		Voltage (V)	Evap. Motor (cv)	Total Current			
			Nom.	Máx.			RLA	FLA	Partida	
1 x 7,5 TR 1 x 5 TR	1 x 0,75 CV 1 x 0,25 CV	1 x 2 CV	16,23	20,24	220	2	54,32	64,64	244,64	
						3	57,08	68,09	248,09	
						4	58,02	69,26	249,26	
		1 x 3 CV	16,79	20,94		380	2	36,39	42,65	155,59
							3	37,98	44,64	157,58
							4	38,52	45,31	158,25
		1 x 4 CV	17,43	21,74	440		2	27,52	32,43	118,51
							3	28,90	34,16	120,24
							4	29,37	34,74	120,82

Tab. VIII-10 - Electrical data Solution Plus 150 (1ckt) with TRAE

Compressor	Condenser Motor	Evaporator Motor	Total Cons. (kW)		Voltage (V)	Evap. Motor (cv)	Total Current			
			Nom.	Máx.			RLA	FLA	Partida	
1 x 15 TR	2 x 0,75 CV	1 x 2 CV	18,75	23,05	220	2	63,77	74,90	383,28	
						3	66,53	78,35	386,73	
						5	69,55	82,12	390,50	
		1 x 3 CV	19,31	23,75		380	2	41,42	48,04	268,54
							3	43,01	50,03	270,53
							5	44,75	52,20	272,70
		1 x 5 CV	20,51	25,25	440		2	31,58	37,15	212,24
							3	32,96	38,88	213,97
							5	34,47	40,76	215,85

Notes:

- (1) RLA = Rated Load Amps(A);
- (2) FLA = Full Load Amps (A);
- (3) Cominal consumption as per ARI standard.;
- (4) Evaporator motor oa a 4-pole motor with Forward-Curved fan; for 2-pole motor (Backward-Curved);
- (5) Voltage variation: +/- 10%;
- (6) Electrical wiring should be sized using Full Load Amps (FLA) in the table above.

Electrical Characteristics

DXPA - TRAE
(60Hz)

Tab. VIII-11 - Electrical data Solution Plus 150 (2 ckt) with TRAE

Compressor	Condenser Motor	Evaporator Motor	Total Cons. (kW)		Voltage (V)	Evap. Motor (cv)	Total Current			
			Nom.	Máx.			RLA	FLA	Partida	
2 x 7,5 TR	2 x 0,75 CV	1 x 2 CV	19,44	24,26	220	2	66,26	78,28	249,68	
						3	69,02	81,73	253,13	
						5	72,04	85,50	256,90	
		1 x 3 CV	20,00	24,96		380	2	44,23	51,66	156,00
							3	45,82	53,65	157,99
							5	47,56	55,82	160,16
1 x 5 CV	21,20	26,46	440	2	33,03		39,08	121,16		
				3	34,41		40,81	122,89		
				5	35,92		42,69	124,77		

Tab. VIII-12 - Electrical data Solution Plus 200 (1ckt) with TRAE.

Compressor	Condenser Motor	Evaporator Motor	Total Cons. (kW)		Voltage (V)	Evap. Motor (cv)	Total Current				
			Nom.	Máx.			RLA	FLA	Partida		
1 x 20 TR	1 x 1,0 CV	1 x 2 CV	24,51	30,43	220	2	84,65	97,92	505,68		
						3	87,41	101,37	509,13		
						5	90,43	105,14	512,90		
						7,5	95,63	111,64	519,40		
		1 x 3 CV	25,07	31,13		380	2	48,79	58,14	277,94	
							3	50,38	60,13	279,93	
							5	52,12	62,30	282,10	
							7,5	55,12	66,06	285,86	
		1 x 5 CV	26,27	32,63			440	2	36,21	44,19	224,94
								3	37,59	45,92	226,67
								5	39,10	47,80	228,55
								7,5	41,70	51,05	231,80

Tab. VIII-13 - Electrical data Solution Plus 200 (2ckt) with TRAE.

Compressor	Condenser Motor	Evaporator Motor	Total Cons. (kW)		Voltage (V)	Evap. Motor (cv)	Total Current				
			Nom.	Máx.			RLA	FLA	Partida		
2 x 10 TR	1 x 1,0 CV	1 x 2 CV	21,87	27,27	220	2	72,64	86,40	315,89		
						3	75,40	89,85	319,34		
						5	78,42	93,62	323,11		
						7,5	83,62	100,12	329,61		
		1 x 3 CV	22,43	27,97		380	2	45,87	54,18	191,41	
							3	47,46	56,17	193,40	
							5	49,20	58,34	195,57	
							7,5	52,20	62,10	199,33	
		1 x 5 CV	23,63	29,47			440	2	35,57	42,32	165,98
								3	36,95	44,05	167,71
								5	38,46	45,93	169,59
								7,5	41,06	49,18	172,84

Notes:

- (1) RLA = Rated Load Amps(A);
- (2) FLA = Full Load Amps (A);
- (3) Cominal consumption as per ARI standard.;
- (4) Evaporator motor oa a 4-pole motor with Forward-Curved fan; for 2-pole motor (Backward-Curved);
- (5) Voltage variation: +/- 10%;
- (6) Electrical wiring should be sized using Full Load Amps (FLA) in the table above.

Electrical Characteristics

DXPA - TRAE
(60Hz)

Tab. VIII-14 - Electrical data Solution Plus 250 (1ckt) with TRAE

Compressor	Condenser Motor	Evaporator Motor	Total Cons. (kW)		Voltage (V)	Evap. Motor (cv)	Total Current				
			Nom.	Máx.			RLA	FLA	Partida		
1 x 25 TR	1 x 1,0 CV	1 x 3 CV	29,72	37,24	220	3	94,18	113,51	584,13		
							5	97,20	117,28	587,90	
							7,5	102,40	123,78	594,40	
		1 x 5 CV	30,92	38,74		380	3	58,14	70,18	329,93	
								5	59,88	72,35	332,10
								7,5	62,88	76,11	335,86
1 x 7,5 CV	32,36	40,54	440	3	45,58	55,36	271,67				
					5	47,09	57,24	273,55			
					7,5	49,69	60,49	276,80			
1 x 10 CV	33,96	42,54	440	7,5	49,69	60,49	276,80				
					10	51,93	63,29	279,60			

Tab. VIII-15 - Electrical data Solution Plus 250 (2ckt) with TRAE

Compressor	Condenser Motor	Evaporator Motor	Total Cons. (kW)		Voltage (V)	Evap. Motor (cv)	Total Current				
			Nom.	Máx.			RLA	FLA	Partida		
2 x 12,5 TR	1 x 1,0 CV	1 x 3 CV	28,39	35,39	220	3	90,38	108,35	365,59		
							5	93,40	112,12	369,36	
							7,5	98,60	118,62	375,86	
		1 x 5 CV	29,59	36,89		380	3	57,16	68,15	207,39	
								5	58,90	70,32	209,56
								7,5	61,90	74,08	213,32
1 x 7,5 CV	31,03	38,69	440	3	44,39	53,23	177,30				
					5	45,90	55,11	179,18			
					7,5	48,50	58,36	182,43			
1 x 10 CV	32,63	40,69	440	7,5	48,50	58,36	182,43				
					10	50,74	61,16	185,23			

Notes:

- (1) RLA = Rated Load Amps(A);
- (2) FLA = Full Load Amps (A);
- (3) Cominal consumption as per ARI standard.;
- (4) Evaporator motor oa a 4-pole motor with Forward-Curved fan; for 2-pole motor (Backward-Curved);
- (5) Voltage variation: +/- 10%;
- (6) Electrical wiring should be sized using Full Load Amps (FLA) in the table above.

Electrical Characteristics

DXPA - TRAE
(60Hz)

Tab. VIII-16 - Electrical data Solution Plus 300 with TRAE

Compressor	Condenser Motor	Evaporator Motor	Total Cons. (kW)		Voltage (V)	Evap. Motor (cv)	Total Current			
			Nom.	Máx.			RLA	FLA	Partida	
1 x 15 TR 1 x 15 TR	2 x 0,75 CV	1 x 3 CV	36,86	45,30	220	3	125,12	146,77	455,15	
							128,14	150,54	458,92	
							133,34	157,04	465,42	
		1 x 5 CV	38,06	46,80		137,82	162,64	471,02		
						380	3	81,44	94,33	314,83
						5	83,18	96,50	317,00	
	2 x 0,75 CV	1 x 7,5 CV	39,50	48,60	380	7,5	86,18	100,26	320,76	
							10	88,77	103,49	323,99
							440	3	61,95	72,79
	2 x 0,75 CV	1 x 10 CV	41,10	50,60	440	5	63,46	74,67	249,76	
							7,5	66,06	77,92	253,01
							10	68,30	80,72	255,81

Tab. VIII-17 - Electrical data Solution Plus 350 with TRAE

Compressor	Condenser Motor	Evaporator Motor	Total Cons. (kW)		Voltage (V)	Evap. Motor (cv)	Total Current			
			Nom.	Máx.			RLA	FLA	Partida	
1 x 20 TR 1 x 15 TR	1 x 1,0 CV 2 X 0,75 CV	1 x 3 CV	42,62	52,68	220	3	146,00	169,79	577,55	
							149,02	173,56	581,32	
							154,22	180,06	587,82	
		1 x 5 CV	43,82	54,18		158,70	185,66	593,42		
						15	167,82	197,06	604,82	
						380	3	88,81	104,43	324,23
	2 X 0,75 CV	1 x 7,5 CV	45,26	55,98	380	5	90,55	106,60	326,40	
							7,5	93,55	110,36	330,16
							10	96,14	113,59	333,39
	2 X 0,75 CV	1 x 10 CV	46,86	57,98	380	15	101,40	120,16	339,96	
							3	66,58	79,83	260,58
							5	68,09	81,71	262,46
2 X 0,75 CV	1 x 15 CV	49,66	61,48	440	7,5	70,69	84,96	265,71		
						10	72,93	87,76	268,51	
						15	77,49	93,46	274,21	

Notes:

- (1) RLA = Rated Load Amps(A);
- (2) FLA = Full Load Amps (A);
- (3) Cominal consumption as per ARI standard.;
- (4) Evaporator motor oca a 4-pole motor with Forward-Curved fan; for 2-pole motor (Backward-Curved);
- (5) Voltage variation: +/- 10%;
- (6) Electrical wiring should be sized using Full Load Amps (FLA) in the table above.

Electrical Characteristics

DXPA - TRAE
(60Hz)

Tab. VIII-18 - Electrical data Solution Plus 400 with TRAE

Compressor	Condenser Motor	Evaporator Motor	Total Cons. (kW)		Voltage (V)	Evap. Motor (cv)	Total Current			
			Nom.	Máx.			RLA	FLA	Partida	
1 x 20 TR 1 x 20 TR	1 x 1,0 CV 1 x 1,0 CV	1 x 5 CV	49,58	61,56	220	5	169,90	196,58	604,34	
						7,5	175,10	203,08	610,84	
						10	179,58	208,68	616,44	
						15	188,70	220,08	627,84	
		1 x 7,5 CV	51,02	63,36		380	5	97,92	116,70	336,50
							7,5	100,92	120,46	340,26
							10	103,51	123,69	343,49
							15	108,77	130,26	350,06
1 x 10 CV	52,62	65,36	440	5	72,72		88,75	269,50		
				7,5	75,32		92,00	272,75		
				10	77,56		94,80	275,55		
				15	82,12		100,50	281,25		
1 x 15 CV	55,42	68,86								

Tab. VIII-19 - Electrical data Solution Plus 500 with TRAE

Compressor	Condenser Motor	Evaporator Motor	Total Cons. (kW)		Voltage (V)	Evap. Motor (cv)	Total Current			
			Nom.	Máx.			RLA	FLA	Partida	
1 x 25 TR 1 x 25 TR	1 x 1,0 CV 1 x 1,0 CV	1 x 5 CV	58,88	73,78	220	5	183,44	220,86	691,48	
						7,5	188,64	227,36	697,98	
						10	193,12	232,96	703,58	
						15	202,24	244,36	714,98	
		1 x 7,5 CV	60,32	75,58		380	5	113,44	136,80	396,55
							7,5	116,44	140,56	400,31
							10	119,03	143,79	403,54
							15	124,29	150,36	410,11
1 x 10 CV	61,92	77,58	440	5	88,70		107,63	323,94		
				7,5	91,30		110,88	327,19		
				10	93,54		113,68	329,99		
				15	98,10		119,38	335,69		
1 x 15 CV	64,72	81,08								

Notes:

- (1) RLA = Rated Load Amps(A);
- (2) FLA = Full Load Amps (A);
- (3) Cominal consumption as per ARI standard.;
- (4) Evaporator motor oa a 4-pole motor with Forward-Curved fan; for 2-pole motor (Backward-Curved);
- (5) Voltage variation: +/- 10%;
- (6) Electrical wiring should be sized using Full Load Amps (FLA) in the table above.

Electrical Characteristics

DLPA - TRAE
(60Hz)

Tab. VIII-20 - Electrical data Solution Plus 050 DLPA with TRAE.

Compressor	Condenser Motor	Evaporator Motor	Total Cons. (kW)		Voltage (V)	Evap. Motor (cv)	Total Current			
			Nom.	Máx.			RLA	FLA	Partida	
1 x 5 TR	1 x 0,25 CV	1 x 1 CV	6,51	8,11	220	1	21,22	25,53	176,65	
						2	23,10	27,88	179,00	
						3	25,08	30,36	181,48	
		1 x 2 CV	7,11	8,86		380	1	14,29	16,84	101,27
							2	15,37	18,19	102,62
							3	16,52	19,62	104,05
1 x 3 CV	7,67	9,56	440	1	11,02		12,91	87,02		
				2	11,96		14,08	88,19		
				3	12,95		15,32	89,43		

Tab. VIII-21 - Electrical data Solution Plus 075 DLPA with TRAE.

Compressor	Condenser Motor	Evaporator Motor	Total Cons. (kW)		Voltage (V)	Evap. Motor (cv)	Total Current				
			Nom.	Máx.			RLA	FLA	Partida		
1 x 7,5 TR	1 x 0,75 CV	1 x 1,5 CV	10,32	12,88	220	2	35,04	41,52	221,52		
						3	37,02	44,00	224,00		
						5	40,78	48,70	228,70		
		1 x 2 CV	10,88	13,58		380	2	23,21	27,20	140,14	
							3	24,36	28,63	141,57	
							5	26,53	31,35	144,29	
		1 x 3 CV	12,08	15,08			440	2	17,47	20,73	106,81
								3	18,46	21,97	108,05
								5	20,34	24,32	110,40

Tab. VIII-22 - Electrical data Solution Plus 100 (1 ckt) DLPA with TRAE

Compressor	Condenser Motor	Evaporator Motor	Total Cons. (kW)		Voltage (V)	Evap. Motor (cv)	Total Current				
			Nom.	Máx.			RLA	FLA	Partida		
1 x 10 TR	1 x 1,0 CV	1 x 2 CV	12,47	15,46	220	3	42,66	50,51	289,30		
						5	46,42	55,21	294,00		
						7,5	51,22	61,21	300,00		
		1 x 3 CV	13,67	16,96		380	3	27,63	32,34	178,87	
							5	29,80	35,06	181,59	
							7,5	32,57	38,52	185,05	
		1 x 4 CV	15,11	18,76			440	3	20,93	24,79	152,75
								5	22,81	27,14	155,10
								7,5	25,21	30,14	158,10

Notes:

- (1) RLA = Rated Load Amps(A);
- (2) FLA = Full Load Amps (A);
- (3) Cominal consumption as per ARI standard.;
- (4) Evaporator motor oa a 4-pole motor with Forward-Curved fan; for 2-pole motor (Backward-Curved);
- (5) Voltage variation: +/- 10%;
- (6) Electrical wiring should be sized using Full Load Amps (FLA) in the table above.

Electrical Characteristics

DLPA - TRAE
(60Hz)

Tab. VIII-23 - Electrical data Solution Plus 100 (2 ckt) DLPA with TRAE

Compressor	Condenser Motor	Evaporator Motor	Total Cons. (kW)		Voltage (V)	Evap. Motor (cv)	Total Current		
			Nom.	Máx.			RLA	FLA	Partida
2 x 5 TR	1 x 1,0 CV	1 x 2 CV	13,97	17,31	220	3	45,00	53,94	203,47
						5	48,76	58,64	208,17
						7,5	53,56	64,64	214,17
		1 x 3 CV	15,17	18,81	380	3	30,62	35,89	118,73
						5	32,79	38,61	121,45
						7,5	35,56	42,07	124,91
1 x 4 CV	16,61	20,61	440	3	21,48	25,41	97,93		
				5	23,36	27,76	100,28		
				7,5	25,76	30,76	103,28		

Tab. VIII-24 - Electrical data Solution Plus 125 (2 ckt) with TRAE075+TRAE050 DLPA with TRAE

Compressor	Condenser Motor	Evaporator Motor	Total Cons. (kW)		Voltage (V)	Evap. Motor (cv)	Total Current		
			Nom.	Máx.			RLA	FLA	Partida
1 x 7,5 TR 1 x 5 TR	1 x 0,75 CV 1 x 0,25 CV	1 x 2 CV	16,79	20,94	220	3	55,62	66,26	246,26
						5	59,38	70,96	250,96
						7,5	64,18	76,96	256,96
		1 x 3 CV	17,99	22,44	380	3	37,14	43,58	156,52
						5	39,31	46,30	159,24
						7,5	42,08	49,76	162,70
1 x 4 CV	19,43	24,24	440	3	28,17	33,24	119,32		
				5	30,05	35,59	121,67		
				7,5	32,45	38,59	124,67		

Tab. VIII-25 - Electrical data Solution Plus 150 (1ckt) DLPA / TRAE

Compressor	Condenser Motor	Evaporator Motor	Total Cons. (kW)		Voltage (V)	Evap. Motor (cv)	Total Current		
			Nom.	Máx.			RLA	FLA	Partida
1 x 15 TR	2 x 0,75 CV	1 x 2 CV	20,51	25,25	220	5	68,83	81,22	389,60
						7,5	73,63	87,22	395,60
						10	78,59	93,42	401,80
		1 x 3 CV	21,95	27,05	380	5	44,34	51,69	272,19
						7,5	47,11	55,15	275,65
						10	49,97	58,73	279,23
1 x 5 CV	23,55	29,05	440	5	34,11	40,31	215,40		
				7,5	36,51	43,31	218,40		
				10	38,99	46,41	221,50		

Notes:

- (1) RLA = Rated Load Amps(A);
- (2) FLA = Full Load Amps (A);
- (3) Cominal consumption as per ARI standard.;
- (4) Evaporator motor oa a 4-pole motor with Forward-Curved fan; for 2-pole motor (Backward-Curved);
- (5) Voltage variation: +/- 10%;
- (6) Electrical wiring should be sized using Full Load Amps (FLA) in the table above.

Electrical Characteristics

DLPA - TRAE
(60Hz)

Tab. VIII-26 - Electrical data Solution Plus 150 (2 ckt) DLPA with TRAE

Compressor	Condenser Motor	Evaporator Motor	Total Cons. (kW)		Voltage (V)	Evap. Motor (cv)	Total Current			
			Nom.	Máx.			RLA	FLA	Partida	
2 x 7,5 TR	2 x 0,75 CV	1 x 2 CV	21,20	26,46	220	5	71,32	84,60	256,00	
						7,5	76,12	90,60	262,00	
						10	81,08	96,80	268,20	
		1 x 3 CV	22,64	28,26		380	5	47,15	55,31	159,65
							7,5	49,92	58,77	163,11
							10	52,78	62,35	166,69
1 x 5 CV	24,24	30,26	440	5	35,56		42,24	124,32		
				7,5	37,96		45,24	127,32		
				10	40,44		48,34	130,42		

Tab. VIII-27 - Electrical data Solution Plus 200 (1ckt) DLPA with TRAE

Compressor	Condenser Motor	Evaporator Motor	Total Cons. (kW)		Voltage (V)	Evap. Motor (cv)	Total Current				
			Nom.	Máx.			RLA	FLA	Partida		
1 x 20 TR	1 x 1,0 CV	1 x 2 CV	26,27	32,63	220	5	89,71	104,24	512,00		
						7,5	94,51	110,24	518,00		
						10	99,47	116,44	524,20		
						15	108,43	127,64	535,40		
		1 x 3 CV	27,71	34,43		380	5	51,71	61,79	281,59	
							7,5	54,48	65,25	285,05	
							10	57,34	68,83	288,63	
							15	62,51	75,29	295,09	
		1 x 5 CV	29,31	36,43			440	5	38,74	47,35	228,10
								7,5	41,14	50,35	231,10
								10	43,62	53,45	234,20
								15	48,10	59,05	239,80

Tab. VIII-28 - Electrical data Solution Plus 200 (2ckt) DLPA with TRAE

Compressor	Condenser Motor	Evaporator Motor	Total Cons. (kW)		Voltage (V)	Evap. Motor (cv)	Total Current				
			Nom.	Máx.			RLA	FLA	Partida		
2 x 10 TR	1 x 1,0 CV	1 x 2 CV	23,63	29,47	220	5	77,70	92,72	322,21		
						7,5	82,50	98,72	328,21		
						10	87,46	104,92	334,41		
						15	96,42	116,12	345,61		
		1 x 3 CV	25,07	31,27		380	5	48,79	57,83	195,06	
							7,5	51,56	61,29	198,52	
							10	54,42	64,87	202,10	
							15	59,59	71,33	208,56	
		1 x 5 CV	26,67	33,27			440	5	38,10	45,48	169,14
								7,5	40,50	48,48	172,14
								10	42,98	51,58	175,24
								15	47,46	57,18	180,84

Notes:

- (1) RLA = Rated Load Amps(A);
- (2) FLA = Full Load Amps (A);
- (3) Cominal consumption as per ARI standard.;
- (4) Evaporator motor oa a 4-pole motor with Forward-Curved fan; for 2-pole motor (Backward-Curved);
- (5) Voltage variation: +/- 10%;
- (6) Electrical wiring should be sized using Full Load Amps (FLA) in the table above.

Electrical Characteristics

DLPA - TRAE
(60Hz)

Tab. VIII-29 - Electrical data Solution Plus 250 (1ckt) DLPA with TRAE

Compressor	Condenser Motor	Evaporator Motor	Total Cons. (kW)		Voltage (V)	Evap. Motor (cv)	Total Current			
			Nom.	Máx.			RLA	FLA	Partida	
1 x 25 TR	1 x 1,0 CV	1 x 3 CV	32,36	40,54	220	5	101,28	122,38	593,00	
						7,5	106,24	128,58	599,20	
		10	115,20	139,78		610,40				
		15	126,08	153,38		624,00				
		1 x 5 CV	33,96	42,54	380	5	62,24	75,30	335,05	
						7,5	65,10	78,88	338,63	
1 x 7,5 CV	36,76				46,04	440	10	70,27	85,34	345,09
							15	76,55	93,18	352,93
1 x 10 CV	39,96	50,04	440	5	49,13	59,79	276,10			
				7,5	51,61	62,89	279,20			
				10	56,09	68,49	284,80			
						15	61,53	75,29	291,60	

Tab. VIII-30 - DadElectrical data Solution Plus 250 (2ckt) DLPA with TRAE

Compressor	Condenser Motor	Evaporator Motor	Total Cons. (kW)		Voltage (V)	Evap. Motor (cv)	Total Current			
			Nom.	Máx.			RLA	FLA	Partida	
2 x 12,5 TR	1 x 1,0 CV	1 x 3 CV	31,03	38,69	220	5	97,48	117,22	374,46	
						7,5	102,44	123,42	380,66	
		10	111,40	134,62		391,86				
		15	122,28	148,22		405,46				
		1 x 5 CV	32,63	40,69	380	5	61,26	73,27	212,51	
						7,5	64,12	76,85	216,09	
1 x 7,5 CV	35,43				44,19	440	10	69,29	83,31	222,55
							15	75,57	91,15	230,39
1 x 10 CV	38,63	48,19	440	5	47,94	57,66	181,73			
				7,5	50,42	60,76	184,83			
				10	54,90	66,36	190,43			
						15	60,34	73,16	197,23	

Notes:

- (1) RLA = Rated Load Amps(A);
- (2) FLA = Full Load Amps (A);
- (3) Cominal consumption as per ARI standard.;
- (4) Evaporator motor oa a 4-pole motor with Forward-Curved fan; for 2-pole motor (Backward-Curved);
- (5) Voltage variation: +/- 10%;
- (6) Electrical wiring should be sized using Full Load Amps (FLA) in the table above.

Electrical Characteristics

DLPA - TRAE
(60Hz)

Tab. VIII-31 - Electrical data Solution Plus 300 DLPA with TRAE.

Compressor	Condenser Motor	Evaporator Motor	Total Cons. (kW)		Voltage (V)	Evap. Motor (cv)	Total Current										
			Nom.	Máx.			RLA	FLA	Partida								
1 x 15 TR 1 x 15 TR	2 x 0,75 CV 2 x 0,75 CV	1 x 3 CV	39,50	48,60	220	7,5	132,22	155,64	464,02								
						10	137,18	161,84	470,22								
						15	146,14	173,04	481,42								
		20	157,02	186,64		495,02											
		1 x 5 CV	41,10	50,60		7,5	85,54	99,45	319,95								
						10	88,40	103,03	323,53								
	15				93,57	109,49	329,99										
	1 x 7,5 CV	43,90	54,10	20	99,85	117,33	337,83	7,5	65,50	77,22	252,31						
								10	67,98	80,32	255,41						
								15	72,46	85,92	261,01						
								20	77,90	92,72	267,81						
								1 x 10 CV	47,10	58,10	20	77,90	92,72	267,81	7,5	65,50	77,22
10															67,98	80,32	255,41
15	72,46	85,92	261,01														

Tab. VIII-32 - Electrical data Solution Plus 350 DLPA with TRAE.

Compressor	Condenser Motor	Evaporator Motor	Total Cons. (kW)		Voltage (V)	Evap. Motor (cv)	Total Current										
			Nom.	Máx.			RLA	FLA	Partida								
1 x 20 TR 1 x 15 TR	1 x 1,0 CV 2 X 0,75 CV	1 x 3 CV	45,26	55,98	220	7,5	153,10	178,66	586,42								
						10	158,06	184,86	592,62								
						15	167,02	196,06	603,82								
		20	177,90	209,66		617,42											
		1 x 5 CV	46,86	57,98		7,5	92,91	109,55	329,35								
						10	95,77	113,13	332,93								
	15				100,94	119,59	339,39										
	1 x 7,5 CV	49,66	61,48	20	107,22	127,43	347,23	7,5	70,13	84,26	265,01						
								10	72,61	87,36	268,11						
								15	77,09	92,96	273,71						
								20	82,53	99,76	280,51						
								1 x 15 CV	52,86	65,48	20	82,53	99,76	280,51	7,5	70,13	84,26
10															72,61	87,36	268,11
15	77,09	92,96	273,71														

Notes:

- (1) RLA = Rated Load Amps(A);
- (2) FLA = Full Load Amps (A);
- (3) Cominal consumption as per ARI standard.;
- (4) Evaporator motor oa a 4-pole motor with Forward-Curved fan; for 2-pole motor (Backward-Curved);
- (5) Voltage variation: +/- 10%;
- (6) Electrical wiring should be sized using Full Load Amps (FLA) in the table above.

Electrical Characteristics

DLPA - TRAE
(60Hz)

Tab. VIII-33 - Electrical data Solution Plus 400 DLPA with TRAE.

Compressor	Condenser Motor	Evaporator Motor	Total Cons. (kW)		Voltage (V)	Evap. Motor (cv)	Total Current				
			Nom.	Máx.			RLA	FLA	Partida		
1 x 20 TR 1 x 20 TR	1 x 1,0 CV 1 x 1,0 CV	1 x 5 CV	52,62	65,36	220	10	178,94	207,88	615,64		
							187,90	219,08	626,84		
							198,78	232,68	640,44		
							207,74	243,88	651,64		
		1 x 7,5 CV	55,42	68,86		380	10	103,14	123,23	343,03	
								108,31	129,69	349,49	
								114,59	137,53	357,33	
								119,76	144,00	363,80	
		1 x 10 CV	58,62	72,86			440	10	77,24	94,40	275,15
									81,72	100,00	280,75
									87,16	106,80	287,55
									91,64	112,40	293,15
1 x 15 CV	61,42	76,36									

Tab. VIII-34 - Electrical data Solution Plus 500 DLPA with TRAE.

Compressor	Condenser Motor	Evaporator Motor	Total Cons. (kW)		Voltage (V)	Evap. Motor (cv)	Total Current				
			Nom.	Máx.			RLA	FLA	Partida		
1 x 25 TR 1 x 25 TR	1 x 1,0 CV 1 x 1,0 CV	1 x 5 CV	61,92	77,58	220	10	192,48	232,16	702,78		
							201,44	243,36	713,98		
							212,32	256,96	727,58		
							221,28	268,16	738,78		
		1 x 7,5 CV	64,72	81,08		380	10	118,66	143,33	403,08	
								123,83	149,79	409,54	
								130,11	157,63	417,38	
								135,28	164,10	423,85	
		1 x 10 CV	67,92	85,08			440	10	93,22	113,28	329,59
									97,70	118,88	335,19
									103,14	125,68	341,99
									107,62	131,28	347,59
1 x 15 CV	70,72	88,58									

Notes:

- (1) RLA = Rated Load Amps(A);
- (2) FLA = Full Load Amps (A);
- (3) Cominal consumption as per ARI standard.;
- (4) Evaporator motor oa a 4-pole motor with Forward-Curved fan; for 2-pole motor (Backward-Curved);
- (5) Voltage variation: +/- 10%;
- (6) Electrical wiring should be sized using Full Load Amps (FLA) in the table above.

Electrical Characteristics

DXPA - TRCE
(60Hz)

Tab. VIII-35 - Electrical data Solution Plus 050 DXPA with TRCE.

Compressor	Condenser Motor	Evaporator Motor	Total Cons. (kW)		Voltage (V)	Evap. Motor (cv)	Total Current			
			Nom.	Máx.			RLA	FLA	Partida	
1 x 5 TR	1 x 1,5 CV	1 x 1 CV	7,21	9,03	220	1	23,50	28,83	200,97	
						1,5	24,51	30,09	202,23	
		1 x 1,5 CV	7,49	9,38		380	1	14,85	17,98	113,87
							1,5	15,43	18,71	114,59
440	1	11,26	13,66	97,48						
	1,5	11,77	14,29	98,11						

Tab. VIII-36 - Electrical data Solution Plus 075 DXPA with TRCE.

Compressor	Condenser Motor	Evaporator Motor	Total Cons. (kW)		Voltage (V)	Evap. Motor (cv)	Total Current			
			Nom.	Máx.			RLA	FLA	Partida	
1 x 7,5 TR	1 x 3 CV	1 x 1,5 CV	11,21	14,13	220	1,5	38,03	46,34	285,26	
						2	39,37	48,01	286,93	
						3	42,13	51,46	290,38	
		1 x 2 CV	11,53	14,53		380	1,5	23,12	28,16	171,47
							2	23,89	29,13	172,43
							3	25,49	31,12	174,42
1 x 3 CV	12,09	15,23	440	1,5	19,12		23,29	139,13		
				2	19,78		24,13	139,97		
				3	21,16		25,85	141,69		

Tab. VIII-37 - Electrical data Solution Plus 100 (1 ckt) DXPA with TRCE

Compressor	Condenser Motor	Evaporator Motor	Total Cons. (kW)		Voltage (V)	Evap. Motor (cv)	Total Current			
			Nom.	Máx.			RLA	FLA	Partida	
1 x 10 TR	1 x 4 CV	1 x 2 CV	13,56	17,01	220	2	45,34	55,09	344,52	
						3	48,10	58,54	347,97	
						4	49,04	59,71	349,14	
		1 x 3 CV	14,12	17,71		380	2	27,10	32,91	204,73
							3	28,70	34,90	206,72
							4	29,24	35,58	207,39
1 x 4 CV	14,76	18,51	440	2	22,32		27,13	180,76		
				3	23,70		28,86	182,49		
				4	24,17		29,44	183,07		

Notes:

- (1) RLA = Rated Load Amps(A);
- (2) FLA = Full Load Amps (A);
- (3) Cominal consumption as per ARI standard.;
- (4) Evaporator motor oa a 4-pole motor with Forward-Curved fan; for 2-pole motor (Backward-Curved);
- (5) Voltage variation: +/- 10%;
- (6) Electrical wiring should be sized using Full Load Amps (FLA) in the table above.

Electrical Characteristics

**DXPA - TRCE
(60Hz)**

Tab. VIII-38 - Electrical data Solution Plus 100 (2 ckt) DXPA with TRCE

Compressor	Condenser Motor	Evaporator Motor	Total Cons. (kW)		Voltage (V)	Evap. Motor (cv)	Total Current			
			Nom.	Máx.			RLA	FLA	Partida	
2 x 5 TR	1 x 4 CV	1 x 2 CV	15,06	18,86	220	2	47,68	58,52	208,05	
						3	50,44	61,97	211,50	
						4	51,38	63,14	212,67	
		1 x 3 CV	15,62	19,56		380	2	30,09	36,46	119,30
							3	31,69	38,45	121,29
							4	32,23	39,13	121,97
1 x 4 CV	16,26	20,36	440	2	22,87		27,75	100,27		
				3	24,25		29,48	102,00		
				4	24,72		30,06	102,58		

Tab. VIII-39 - Electrical data Solution Plus 125 (2 ckt) DXPA with TRCE.

Compressor	Condenser Motor	Evaporator Motor	Total Cons. (kW)		Voltage (V)	Evap. Motor (cv)	Total Current				
			Nom.	Máx.			RLA	FLA	Partida		
1 x 7,5 TR 1 x 5 TR	1 x 3 CV 1 x 1,5 CV	1 x 2 CV	18,14	22,81	220	2	60,03	73,29	312,21		
						3	62,79	76,74	315,66		
						4	63,72	77,91	316,83		
		1 x 3 CV	18,70	23,51		380	2	37,11	45,06	188,37	
							3	38,70	47,05	190,36	
							4	39,24	47,73	191,03	
		1 x 4 CV	19,34	24,31			440	2	29,63	36,01	151,85
								3	31,01	37,74	153,58
								4	31,48	38,32	154,16

Tab. VIII-40 - Electrical data Solution Plus 150 (1ckt) DXPA with TRCE

Compressor	Condenser Motor	Evaporator Motor	Total Cons. (kW)		Voltage (V)	Evap. Motor (cv)	Total Current				
			Nom.	Máx.			RLA	FLA	Partida		
1 x 15 TR	1 x 5 CV	1 x 2 CV	20,61	25,65	220	2	66,13	80,00	467,08		
						3	68,89	83,45	470,53		
						5	71,91	87,22	474,30		
		1 x 3 CV	21,17	26,35		380	2	39,15	47,34	305,98	
							3	40,74	49,33	307,97	
							5	42,48	51,51	310,14	
		1 x 5 CV	22,37	27,85			440	2	33,06	40,00	255,04
								3	34,44	41,73	256,77
								5	35,95	43,61	258,65

Notes:

- (1) RLA = Rated Load Amps(A);
- (2) FLA = Full Load Amps (A);
- (3) Cominal consumption as per ARI standard.;
- (4) Evaporator motor oca a 4-pole motor with Forward-Curved fan; for 2-pole motor (Backward-Curved);
- (5) Voltage variation: +/- 10%;
- (6) Electrical wiring should be sized using Full Load Amps (FLA) in the table above.

Electrical Characteristics

**DXPA - TRCE
(60Hz)**

Tab. VIII-41 - Electrical data Solution Plus 150 (2 ckt) DXPA with TRCE - 2 Circuitos.

Compressor	Condenser Motor	Evaporator Motor	Total Cons. (kW)		Voltage (V)	Evap. Motor (cv)	Total Current			
			Nom.	Máx.			RLA	FLA	Partida	
2 x 7,5 TR	1 x 5 CV	1 x 2 CV	21,30	26,86	220	2	68,62	83,38	254,78	
						3	71,38	86,83	258,23	
						5	74,40	90,60	262,00	
		1 x 3 CV	21,86	27,56		380	2	41,96	50,96	155,30
							3	43,55	52,95	157,29
							5	45,29	55,13	159,47
1 x 5 CV	23,06	29,06	440	2	34,51		41,93	124,01		
				3	35,89		43,66	125,74		
				5	37,40		45,54	127,62		

Tab. VIII-42 - Electrical data Solution Plus 200 (2ckt) DXPA with TRCE.

Compressor	Condenser Motor	Evaporator Motor	Total Cons. (kW)		Voltage (V)	Evap. Motor (cv)	Total Current				
			Nom.	Máx.			RLA	FLA	Partida		
1 x 10 TR 1 x 10 TR	1 x 4 CV 1 x 4 CV	1 x 2 CV	25,92	32,52	220	2	85,50	103,70	393,13		
						3	88,26	107,15	396,58		
						5	91,28	110,92	400,35		
						7,5	96,48	117,42	406,85		
		1 x 3 CV	26,48	33,22		380	2	51,22	62,09	233,90	
							3	52,81	64,08	235,89	
							5	54,55	66,25	238,07	
							7,5	57,55	70,00	241,82	
		1 x 5 CV	27,68	34,72			440	2	42,05	51,02	204,65
								3	43,43	52,75	206,38
								5	44,94	54,63	208,26
								7,5	47,54	57,88	211,51
1 x 7,5 CV	29,12	36,52									

Notes:

- (1) RLA = Rated Load Amps(A);
- (2) FLA = Full Load Amps (A);
- (3) Cominal consumption as per ARI standard.;
- (4) Evaporator motor oa a 4-pole motor with Forward-Curved fan; for 2-pole motor (Backward-Curved);
- (5) Voltage variation: +/- 10%;
- (6) Electrical wiring should be sized using Full Load Amps (FLA) in the table above.

Electrical Characteristics

**DXPA - TRCE
(60Hz)**

Tab. VIII-43 - Electrical data Solution Plus 250 (2ckt) DXPA with TRCE.

Compressor	Condenser Motor	Evaporator Motor	Total Cons. (kW)		Voltage (V)	Evap. Motor (cv)	Total Current		
			Nom.	Máx.			RLA	FLA	Partida
1 x 15 TR 1 x 10 TR	1 x 5 CV 1 x 4 CV	1 x 3 CV	33,53	41,86	220	3	109,05	132,06	519,14
						5	112,07	135,83	522,91
						7,5	117,27	142,33	529,41
						10	121,75	147,93	535,01
					3	64,85	78,51	337,14	
					5	66,59	80,68	339,32	
		1 x 5 CV	34,73	43,36	380	7,5	69,59	84,44	343,07
						10	72,18	87,67	346,30
						3	54,17	65,62	280,66
		1 x 7,5 CV	36,17	45,16	440	5	55,68	67,50	282,54
						7,5	58,28	70,75	285,79
						10	60,52	73,55	288,59
						3			
		1 x 10 CV	37,77	47,16					

Tab. VIII-44 - Electrical data Solution Plus 300 DXPA with TRCE.

Compressor	Condenser Motor	Evaporator Motor	Total Cons. (kW)		Voltage (V)	Evap. Motor (cv)	Total Current				
			Nom.	Máx.			RLA	FLA	Partida		
1 x 15 TR 1 x 15 TR	1 x 5 CV 1 x 5 CV	1 x 5 CV	40,58	50,50	220	3	129,84	156,97	544,05		
						5	132,86	160,74	547,82		
						7,5	138,06	167,24	554,32		
						10	142,54	172,84	559,92		
				1 x 7,5 CV	41,78	52,00	380	3	76,89	92,94	351,57
								5	78,63	95,11	353,75
					7,5	81,63		98,87	357,50		
		1 x 10 CV	43,22	53,80	440	10	84,22	102,10	360,73		
						3	64,91	78,49	293,53		
						5	66,42	80,37	295,41		
						7,5	69,02	83,62	298,66		
		1 x 15 CV	44,82	55,80		10	71,26	86,42	301,46		

Notes:

- (1) RLA = Rated Load Amps(A);
- (2) FLA = Full Load Amps (A);
- (3) Cominal consumption as per ARI standard.;
- (4) Evaporator motor oa a 4-pole motor with Forward-Curved fan; for 2-pole motor (Backward-Curved);
- (5) Voltage variation: +/- 10%;
- (6) Electrical wiring should be sized using Full Load Amps (FLA) in the table above.

Electrical Characteristics

DLPA - TRCE
(60Hz)

Tab. VIII-45 - Electrical data Solution Plus 050 DLPA with TRCE.

Compressor	Condenser Motor	Evaporator Motor	Total Cons. (kW)		Voltage (V)	Evap. Motor (cv)	Total Current			
			Nom.	Máx.			RLA	FLA	Partida	
1 x 5 TR	1 x 1,5 CV	1 x 1 CV	7,21	9,03	220	1	23,27	28,55	200,69	
						2	25,15	30,90	203,04	
						3	27,14	33,38	205,52	
		1 x 2 CV	7,81	9,78		380	1	14,72	17,82	113,71
							2	15,80	19,18	115,06
							3	16,95	20,61	116,49
1 x 3 CV	8,37	10,48	440	1	11,15		13,52	97,34		
				2	12,09		14,70	98,52		
				3	13,08		15,94	99,76		

Tab. VIII-46 - Electrical data Solution Plus 075 DLPA with TRCE.

Compressor	Condenser Motor	Evaporator Motor	Total Cons. (kW)		Voltage (V)	Evap. Motor (cv)	Total Current				
			Nom.	Máx.			RLA	FLA	Partida		
1 x 7,5 TR	1 x 3 CV	1 x 1,5 CV	11,53	14,53	220	2	38,68	47,15	286,07		
						3	40,66	49,63	288,55		
						5	44,42	54,33	293,25		
		1 x 2 CV	12,09	15,23		380	2	23,50	28,63	171,93	
							3	24,64	30,06	173,36	
							5	26,81	32,78	176,08	
		1 x 3 CV	13,29	16,73			440	2	19,44	23,70	139,54
								3	20,43	24,94	140,78
								5	22,31	27,29	143,13

Tab. VIII-47 - Electrical data Solution Plus 100 (1 ckt) DLPA with TRCE

Compressor	Condenser Motor	Evaporator Motor	Total Cons. (kW)		Voltage (V)	Evap. Motor (cv)	Total Current				
			Nom.	Máx.			RLA	FLA	Partida		
1 x 10 TR	1 x 4 CV	1 x 2 CV	14,12	17,71	220	3	46,64	56,71	346,14		
						5	50,40	61,41	350,84		
						7,5	55,20	67,41	356,84		
		1 x 3 CV	15,32	19,21		380	3	27,85	33,85	205,66	
							5	30,02	36,56	208,38	
							7,5	32,79	40,02	211,84	
		1 x 4 CV	16,76	21,01			440	3	22,97	27,94	181,57
								5	24,85	30,29	183,92
								7,5	27,25	33,29	186,92

Notes:

- (1) RLA = Rated Load Amps(A);
- (2) FLA = Full Load Amps (A);
- (3) Cominal consumption as per ARI standard.;
- (4) Evaporator motor oa a 4-pole motor with Forward-Curved fan; for 2-pole motor (Backward-Curved);
- (5) Voltage variation: +/- 10%;
- (6) Electrical wiring should be sized using Full Load Amps (FLA) in the table above.

Electrical Characteristics

DLPA - TRCE
(60Hz)

Tab. VIII-48 - Electrical data Solution Plus 100 (2 ckt) DLPA with TRCE

Compressor	Condenser Motor	Evaporator Motor	Total Cons. (kW)		Voltage (V)	Evap. Motor (cv)	Total Current			
			Nom.	Máx.			RLA	FLA	Partida	
2 x 5 TR	1 x 4 CV	1 x 2 CV	15,62	19,56	220	3	48,98	60,14	209,67	
						5	52,74	64,84	214,37	
						7,5	57,54	70,84	220,37	
		1 x 3 CV	16,82	21,06		380	3	30,84	37,40	120,24
							5	33,01	40,11	122,95
							7,5	35,78	43,57	126,41
1 x 4 CV	18,26	22,86	440	3	23,52		28,56	101,08		
				5	25,40		30,91	103,43		
				7,5	27,80		33,91	106,43		

Tab. VIII-49 - Electrical data Solution Plus 125 (2 ckt) with TRCE075+TRCE050 DLPA with TRCE.

Compressor	Condenser Motor	Evaporator Motor	Total Cons. (kW)		Voltage (V)	Evap. Motor (cv)	Total Current				
			Nom.	Máx.			RLA	FLA	Partida		
1 x 7,5 TR 1 x 5 TR	1 x 3 CV 1 x 1,5 CV	1 x 2 CV	18,70	23,51	220	3	61,32	74,91	313,83		
						5	65,08	79,61	318,53		
						7,5	69,88	85,61	324,53		
		1 x 3 CV	19,90	25,01		380	3	37,85	46,00	189,30	
							5	40,02	48,71	192,01	
							7,5	42,79	52,17	195,47	
		1 x 4 CV	21,34	26,81			440	3	30,28	36,82	152,66
								5	32,16	39,17	155,01
								7,5	34,56	42,17	158,01

Tab. VIII-50 - Electrical data Solution Plus 150 (1ckt) DLPA with TRCE

Compressor	Condenser Motor	Evaporator Motor	Total Cons. (kW)		Voltage (V)	Evap. Motor (cv)	Total Current			
			Nom.	Máx.			RLA	FLA	Partida	
1 x 15 TR	1 x 5 CV	1 x 2 CV	22,37	27,85	220	5	71,19	86,32	473,40	
						7,5	75,99	92,32	479,40	
						10	80,95	98,52	485,60	
		1 x 3 CV	23,81	29,65		380	5	42,06	50,99	309,62
							7,5	44,83	54,45	313,09
							10	47,69	58,03	316,66
1 x 5 CV	25,41	31,65	440	5	35,59		43,16	258,20		
				7,5	37,99		46,16	261,20		
				10	40,47		49,26	264,30		

Notes:

- (1) RLA = Rated Load Amps(A);
- (2) FLA = Full Load Amps (A);
- (3) Cominal consumption as per ARI standard.;
- (4) Evaporator motor oa a 4-pole motor with Forward-Curved fan; for 2-pole motor (Backward-Curved);
- (5) Voltage variation: +/- 10%;
- (6) Electrical wiring should be sized using Full Load Amps (FLA) in the table above.

Electrical Characteristics

DLPA - TRCE
(60Hz)

Tab. VIII-51 - Electrical data Solution Plus 150 (2 ckt) DLPA with TRCE -2 Circuitos.

Compressor	Condenser Motor	Evaporator Motor	Total Cons. (kW)		Voltage (V)	Evap. Motor (cv)	Total Current		
			Nom.	Máx.			RLA	FLA	Partida
		1 x 2 CV	23,06	29,06	220	5	73,68	89,70	261,10
						7,5	78,48	95,70	267,10
						10	83,44	101,90	273,30
2 x 7,5 TR	1 x 5 CV	1 x 3 CV	24,50	30,86	380	5	44,87	54,61	158,95
						7,5	47,64	58,07	162,41
						10	50,50	61,65	165,99
		1 x 5 CV	26,10	32,86	440	5	37,04	45,09	127,17
						7,5	39,44	48,09	130,17
						10	41,92	51,19	133,27

Tab. VIII-52 - Electrical data Solution Plus 200 (2ckt) DLPA with TRCE.

Compressor	Condenser Motor	Evaporator Motor	Total Cons. (kW)		Voltage (V)	Evap. Motor (cv)	Total Current		
			Nom.	Máx.			RLA	FLA	Partida
		1 x 2 CV	27,68	34,72	220	5	90,56	110,02	399,45
						7,5	95,36	116,02	405,45
						10	100,32	122,22	411,65
1 x 10 TR 1 x 10 TR	1 x 4 CV 1 x 4 CV	1 x 3 CV	29,12	36,52	380	15	109,28	133,42	422,85
						5	54,14	65,74	237,55
						7,5	56,91	69,20	241,01
		1 x 5 CV	30,72	38,52	440	10	59,77	72,77	244,59
						15	64,94	79,24	251,05
						5	44,58	54,18	207,81
		1 x 7,5 CV	33,52	42,02	440	7,5	46,98	57,18	210,81
						10	49,46	60,28	213,91
						15	53,94	65,88	219,51

Notes:

- (1) RLA = Rated Load Amps(A);
- (2) FLA = Full Load Amps (A);
- (3) Cominal consumption as per ARI standard.;
- (4) Evaporator motor oa a 4-pole motor with Forward-Curved fan; for 2-pole motor (Backward-Curved);
- (5) Voltage variation: +/- 10%;
- (6) Electrical wiring should be sized using Full Load Amps (FLA) in the table above.

Electrical Characteristics

DLPA - TRCE
(60Hz)

Tab. VIII-53 - Electrical data Solution Plus 250 (2ckt) DLPA with TRCE.

Compressor	Condenser Motor	Evaporator Motor	Total Cons. (kW)		Voltage (V)	Evap. Motor (cv)	Total Current				
			Nom.	Máx.			RLA	FLA	Partida		
1 x 15 TR 1 x 10 TR	1 x 5 CV 1 x 4 CV	1 x 3 CV	36,17	45,16	220	5	116,15	140,93	528,01		
						7,5	121,11	147,13	534,21		
						10	130,07	158,33	545,41		
		15	140,95	171,93		559,01					
		1 x 5 CV	37,77	47,16		5	68,95	83,63	342,26		
						7,5	71,81	87,20	345,84		
	10				76,98	93,67	352,30				
	1 x 7,5 CV	40,57	50,66	380	15	83,26	101,51	360,15			
					5	57,72	70,05	285,09			
					7,5	60,20	73,15	288,19			
					10	64,68	78,75	293,79			
					1 x 10 CV	43,77	54,66	440	7,5	60,20	73,15
10									64,68	78,75	293,79
						15	70,12	85,55	300,59		

Tab. VIII-54 - Electrical data Solution Plus 300 DLPA with TRCE.

Compressor	Condenser Motor	Evaporator Motor	Total Cons. (kW)		Voltage (V)	Evap. Motor (cv)	Total Current				
			Nom.	Máx.			RLA	FLA	Partida		
1 x 15 TR 1 x 15 TR	1 x 5 CV 1 x 5 CV	1 x 3 CV	44,82	55,80	220	7,5	141,90	172,04	559,12		
						10	150,86	183,24	570,32		
						15	161,74	196,84	583,92		
		20	170,70	208,04		595,12					
		1 x 5 CV	47,62	59,30		7,5	83,85	101,63	360,27		
						10	89,02	108,10	366,73		
	15				95,30	115,94	374,58				
	1 x 7,5 CV	50,82	63,30	380	20	100,47	122,41	381,04			
					7,5	70,94	86,02	301,06			
					10	75,42	91,62	306,66			
					15	80,86	98,42	313,46			
					1 x 10 CV	53,62	66,80	440	7,5	70,94	86,02
10									75,42	91,62	306,66
						15	80,86	98,42	313,46		
						20	85,34	104,02	319,06		

Notes:

- (1) RLA = Rated Load Amps(A);
- (2) FLA = Full Load Amps (A);
- (3) Cominal consumption as per ARI standard.;
- (4) Evaporator motor oa a 4-pole motor with Forward-Curved fan; for 2-pole motor (Backward-Curved);
- (5) Voltage variation: +/- 10%;
- (6) Electrical wiring should be sized using Full Load Amps (FLA) in the table above.

Electrical Characteristics

Fig.VIII-01 - Crankcase Heater

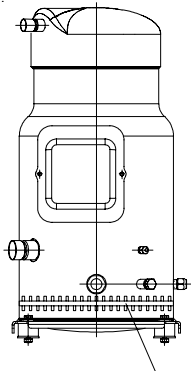

Recommended for position fixing

Crankcase Heater

Trane recommends the use of crankcase heaters when the load of the system refrigerant load exceeds the refrigerant compressor limit (RCL). The needs of crankcase heater are directly related to the possibility of liquid migration to the compressor, and consequently causing poor lubrication of it. Migration can occur during long periods of compressor shutdown (over 8 hours). The crankcase heater is recommended to eliminate the liquid migration when these downtime long periods. The crankcase heater must be installed on the compressor housing and below the removal oil point. The crankcase heater must remain energized while the compressor is off.



Attention:

The crankcase heater must be energized at least 12 hours before the startup of the compressor (with the service valves open) and should be maintained until the compressor energized startup.

This will prevent the dilution of oil and the bearings overload in the initial compressor starts. When the compressor is off, the crankcase temperature should be kept at least 10°C above the refrigerant temperature in the suction side (low pressure side). This requirement ensures that the refrigerant will not be retained in the compressor crankcase. Tests can be done to ensure that the appropriate temperature of the oil is maintained below the ambient conditions (temperature and wind). Therefore, for a temperature below -5°C and an over 5m/s wind speed, it is recommended that the resistors be thermally isolated to limit the energy loss to the environment.

Tab. VIII-55 - Crankcase Heater

Crankcase Heater									
Power W	Voltage V	Trane Code X1314	Mnemonic Code	Quantity	Diameter (mm)		Length (mm)		
					min.	máx.	Conexion Cable	Resistance	Fixing Chape
70	240	X13140710-11	HTR00199B	1	185	210	520	460	60
	480	X13140710-12	HTR00200B	1	185	210	520	460	60
100	240	X13140712-05	HTR12361	1	230	290	460	740	60
	480	X13140712-08	HTR00002B	1	230	290	460	740	60
160	230	X13140712-11	HTR12523	2	300	375	560	890	60
	460	X13140712-14	HTR12525	2	300	375	560	890	60

IX-Electrical Diagrams

050 to 500

Fig. IX-01 - Electrical Diagram - Starter - 050 to 500

(UNLESS OTHERWISE SPECIFIED ALL DIMENSIONS ARE IN MILLIMETERS.) (TOLERANCE) X, = ± X _{10L} (FINISH) ✓ X.X = ± X _{10L} X.XX = ± X _{10L} (ANGLES) = ± (HOLE DIA) (NOT INDICATED TOLERANCES MUST BE USED ISO 2768-1 CLASS MIDDLE)	TRANE (THIS DRAWING IS PROPRIETARY AND SHALL NOT BE COPIED OR ITS CONTENTS DISCLOSED TO OUTSIDE PARTIES WITHOUT THE WRITTEN CONSENT OF TRANE.)		X39010086 PAGE 01/01 REV A	
	(DRAWN BY) EFFGEN DATE 07/02/2005 (CHECKED BY) - DATE - (APPROVED BY) - DATE -	(FIRST ANGLE PROJECTION) 		ELECTRIC SCHEMA WAVE DX HEAT/HUMIDIF. INTERFACE
		(DO NOT SCALE PRINT)	(REPLACE) -	CF 0
				0

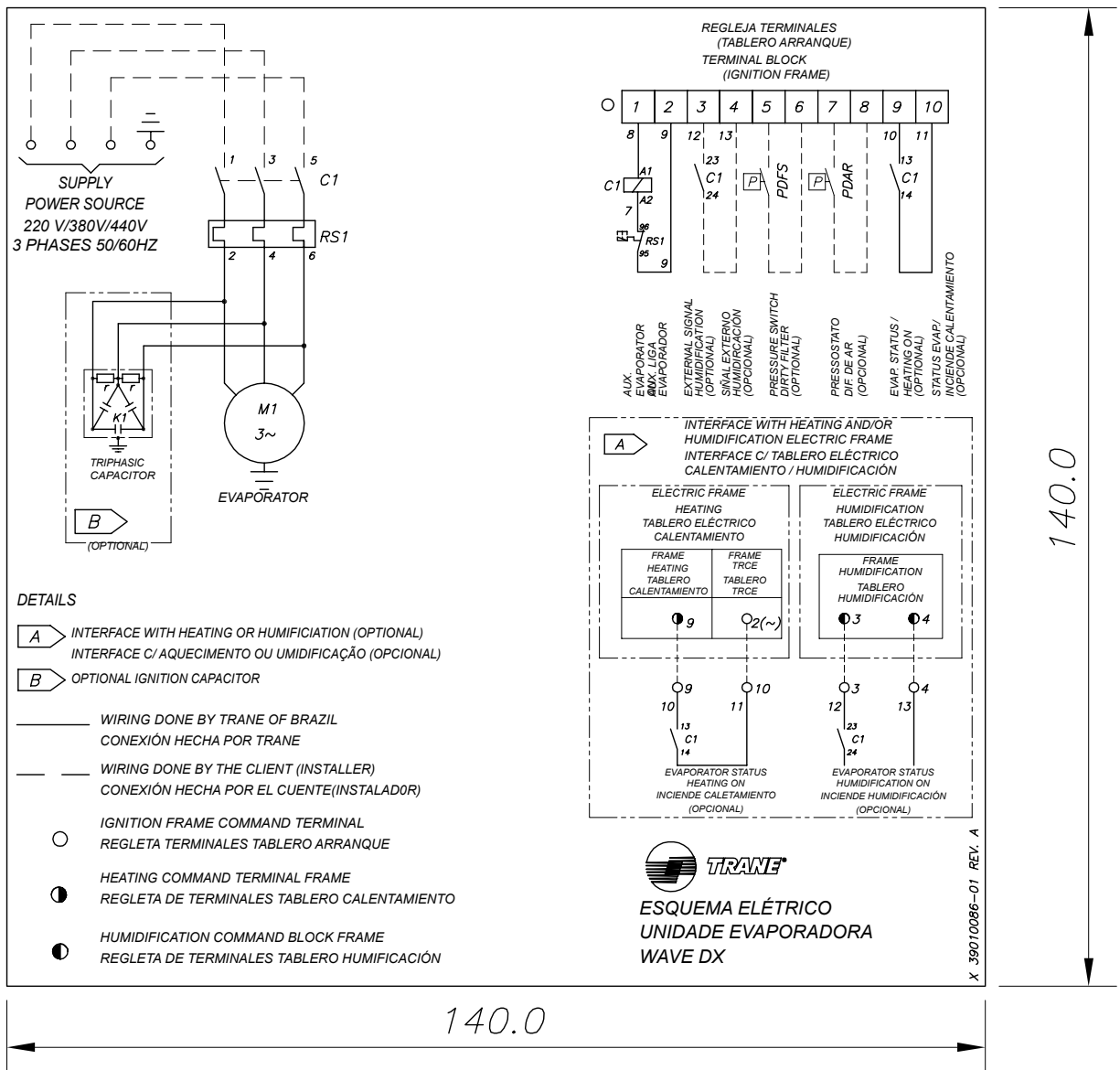

- NOTES:
- 1 - VINYL SELF-ADHESIVE TAG
 - 2 - PERMANENT TYPE ADHESIVE ON THE BACK OF THE TAG
 - 3 - SAYINGS PRINTED IN BLACK WITH A WHITE BACKGROUND

Electrical Diagrams

050 to 500

Fig. IX-02 - Power and Command Wiring Diagram for Heating - 1 or 2 stages (inbuilt direct start panel interface)

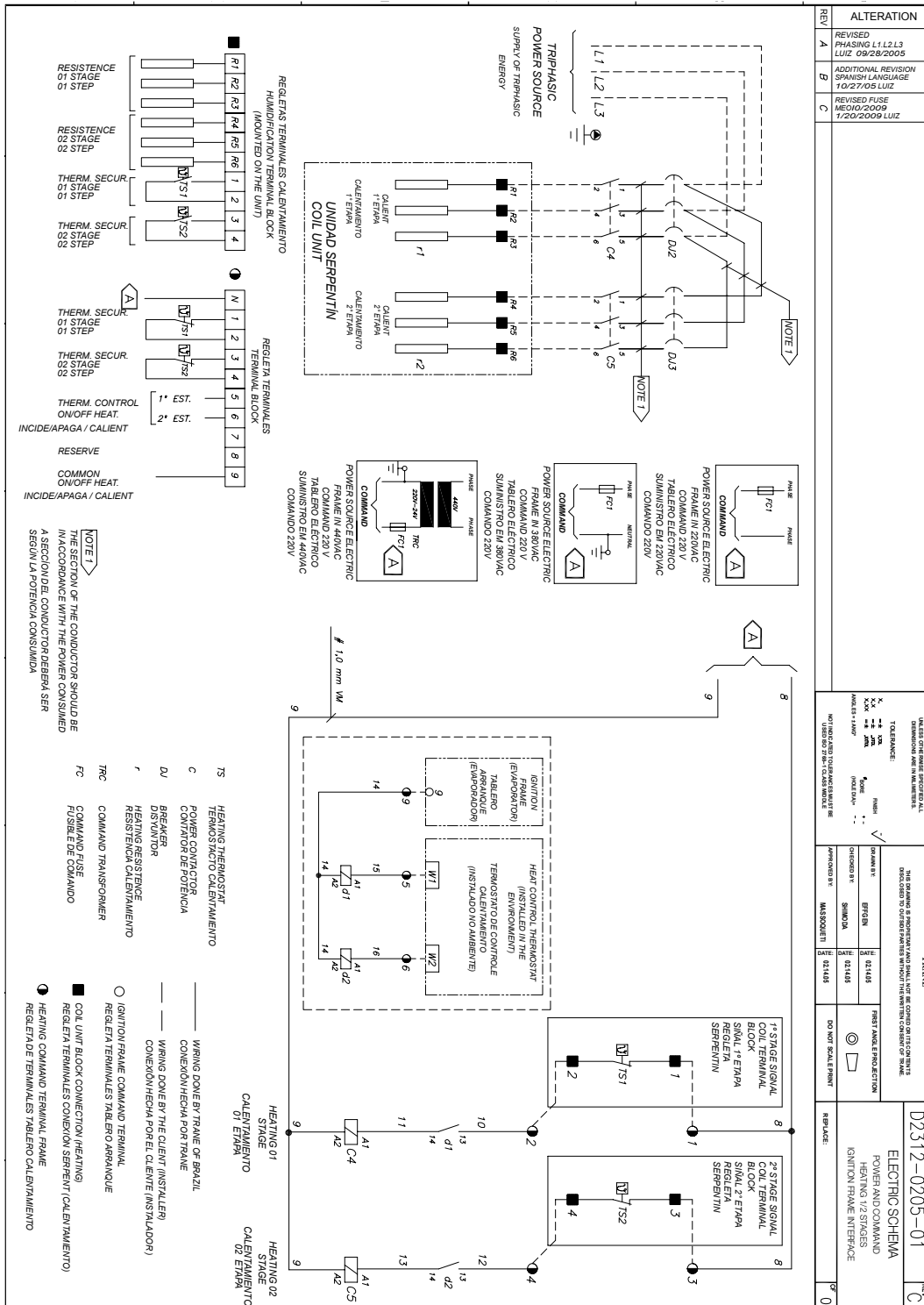

X-Dimensional Data

Module Empty

Fig. X 01 - Dimensions Module Empty 05 to 50 (DX and DL)

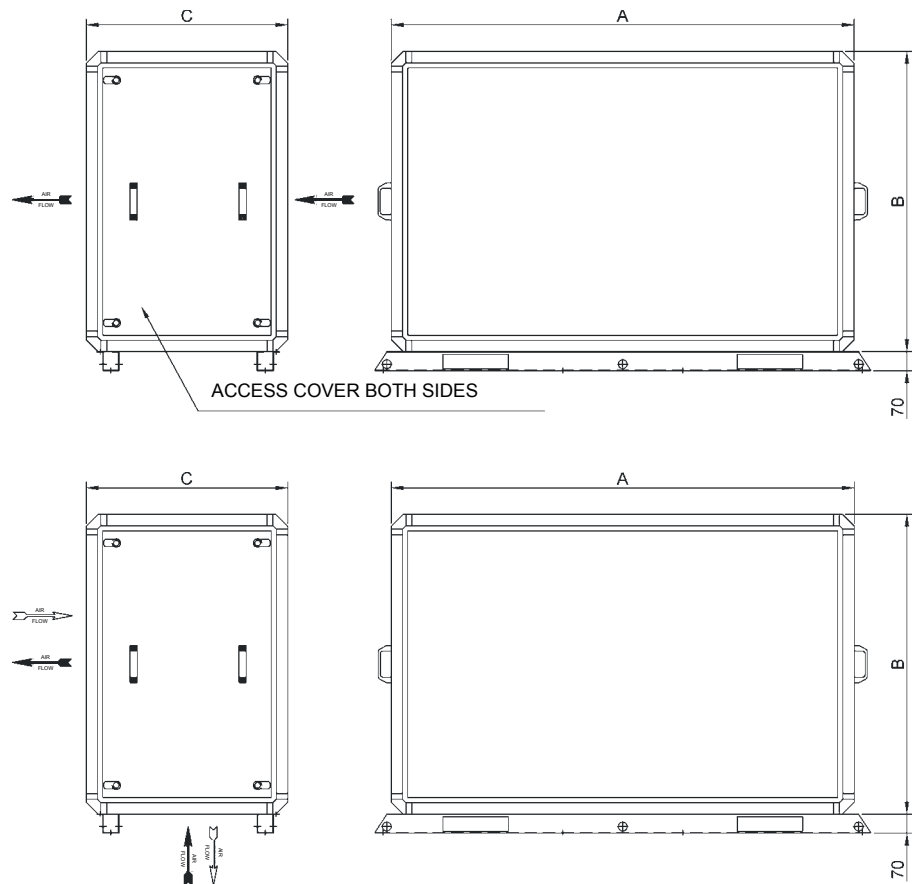

Tab. X 01 - Dimensions Module Empty 05 to 50 Forward-Curved

MOD.	5	7	10	12	15	20	25	30	35	40	50
A	960	1120	1430	1500	1500	2000	2400	2770	2770	2770	2770
B	660	800	800	1100	1100	1100	1100	1100	1300	1300	1300
C	580	740	740	740	740	740	930	930	930	930	930

Tab. X 02 - Dimensions Module Empty 05 to 50 Backward-Curved

MOD.	5	7	10	12	15	20	25	30	35	40	50
A	1120	1300	1430	1500	1700	2000	2400	2770	2770	2770	2770
B	800	900	800	1100	1100	1250	1350	1500	1500	1600	1600
C	740	850	850	740	740	800	930	930	930	1050	1050

Dimensional Data

Return Filter

Fig. X 02 - Dimensions Module Return Filter - F8 Bag + 1" or only F8 Bag (05 to 10) Forward-Curved and Backward-Curved

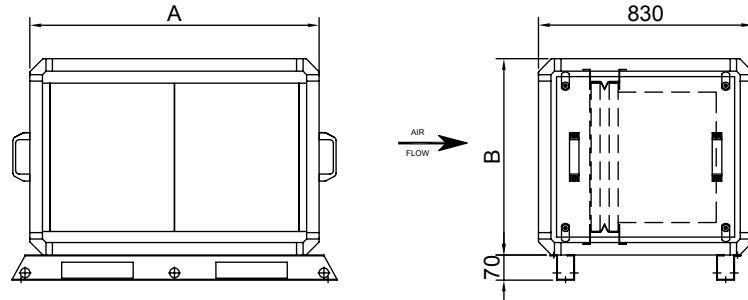

MOD	5	7	10
A	960	1120	1430
B	660	800	800

MOD	5	7	10
A	1120	1300	1430
B	660	800	800

Fig. X 03 - Dimensions Module Return Filter - F8 Bag + 1" or only F8 Bag (12 to 50) Forward-Curved and Backward-Curved

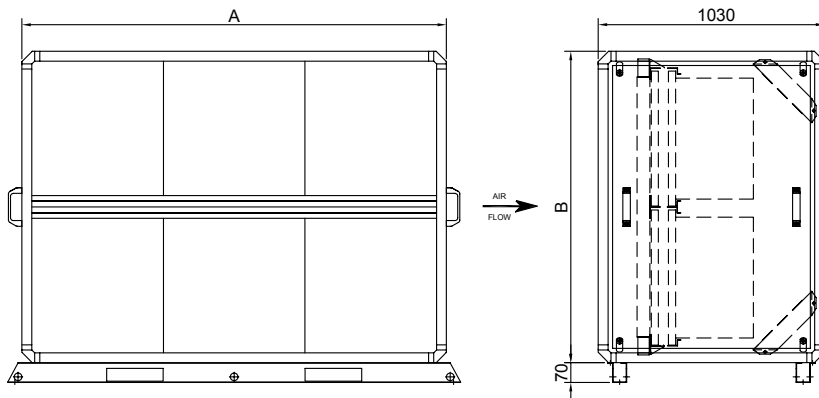

Tab. X 03 - Dimensions Module Return Filter 12 to 50 Forward-Curved

MOD	12	15	20	25	30	35	40	50
A	1500	1500	2000	2400	2770	2770	2770	2770
B	1100	1100	1100	1100	1100	1300	1500	1680

Tab. X 04 - Dimensions Module Return Filter 12 to 50 Backward-Curved

MOD	12	15	20	25	30	35	40	50
A	1500	1700	2000	2400	2770	2770	2770	2770
B	1100	1100	1100	1100	1100	1300	1500	1680

Dimensional Data

Final Filter

Fig. X 04 - Dimensions Module Final Filter 1 Filtering Stage 05 to 50.

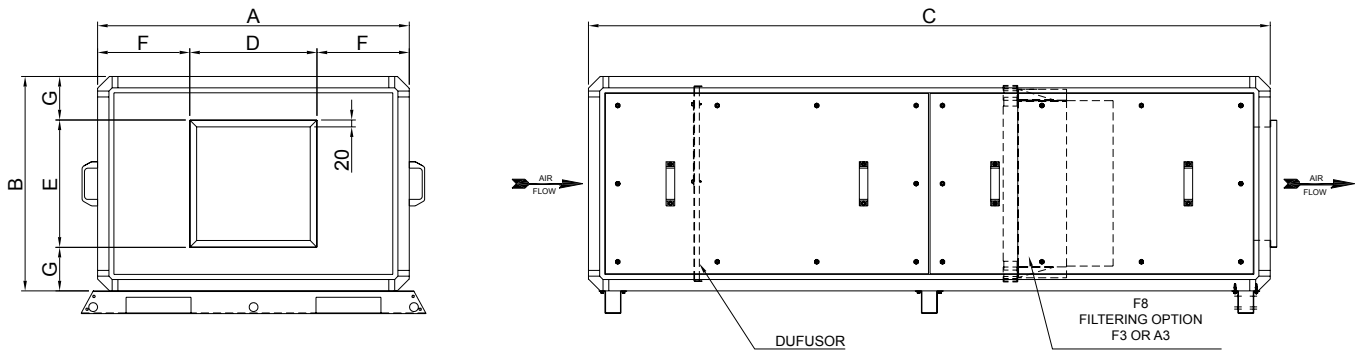

Tab. X 05 - Dimensions Module Final Filter 1 Filtering Stage 05 to 50.

MOD.	5	7	10	12	15	20	25	30	35	40	50
A	1120	1300	1430	1500	1700	2000	2400	2770	2770	2770	2770
B	800	900	800	1100	1100	1250	1350	1500	1500	1600	1600
C	2100	2100	2100	2100	2100	2450	2450	2450	2450	2450	2450
D	540	740	740	740	840	1040	1040	1240	1240	1540	1540
E	390	390	390	440	490	540	640	790	790	790	790
F	290	280	345	380	430	480	680	765	765	615	615
G	205	255	205	330	305	355	355	355	355	405	405

Fig. X 05 - Dimensions Module Final Filter 2 Filtering Stage 05 to 50.

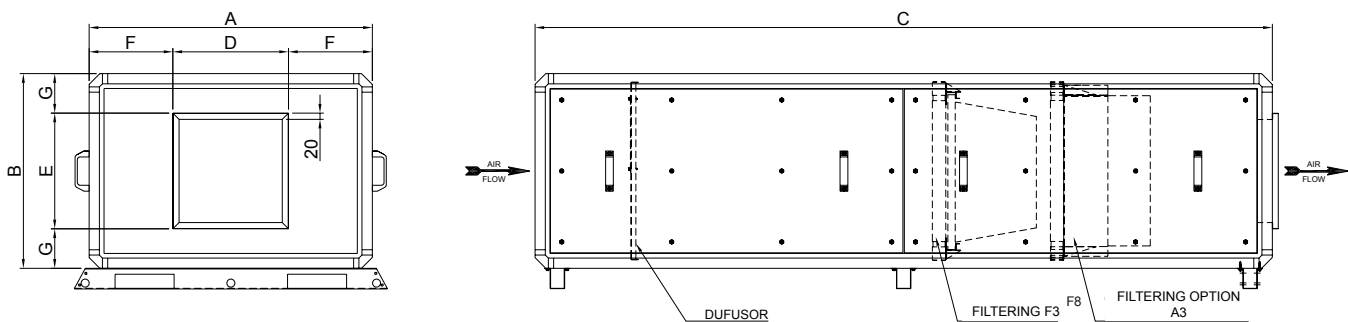

Tab. X 06 - Dimensions Module Final Filter 2 Filtering Stage 05 to 50.

MOD.	5	7	10	12	15	20	25	30	35	40	50
A	1120	1300	1430	1500	1700	2000	2400	2770	2770	2770	2770
B	800	900	800	1100	1100	1250	1350	1500	1500	1600	1600
C	2500	2500	2500	2500	2500	2850	2850	2850	2850	2850	2850
D	540	740	740	740	840	1040	1040	1240	1240	1540	1540
E	390	390	390	440	490	540	640	790	790	790	790
F	290	280	345	380	430	480	680	765	765	615	615
G	205	255	205	330	305	355	355	355	355	405	405

Dimensional Data

Fan Module

Fig. X-06 - Dimensions - Fan Module 05 to 10

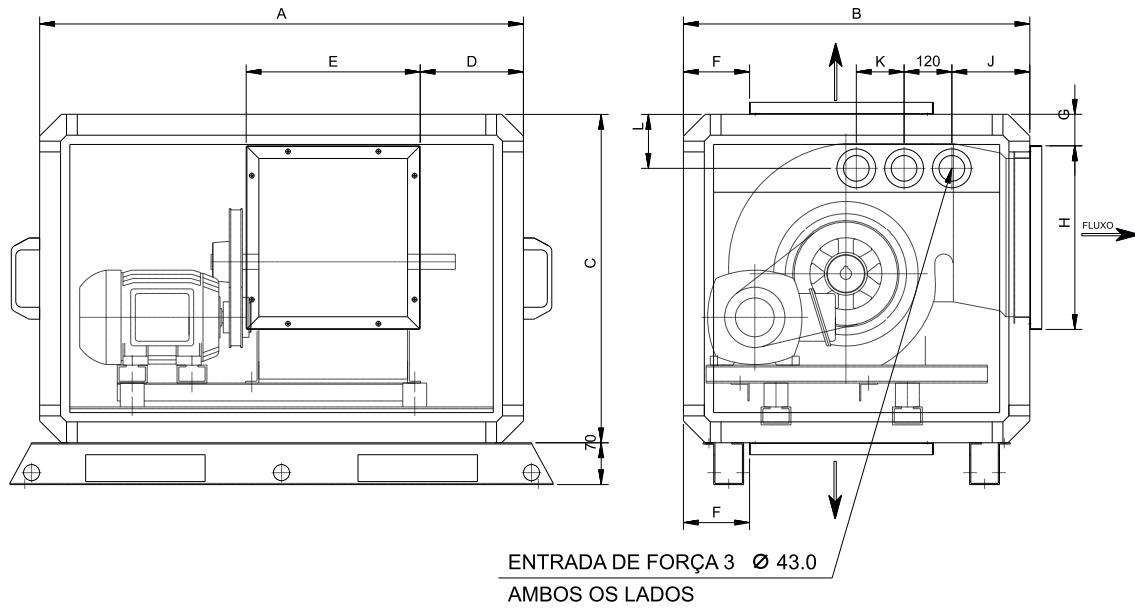

Tab. X-07 - Dimensions - Fan Module 05 to 10 - Forward-Curved

MODEL	A	B	C	D	E	F	G	H	J	K	L
05	860	580	660	189	366	111	89	329	98	120	97
07	1120	740	800	283	412	111	56	442	124	150	112
10	1430	740	800	458	513	111	56	442	124	150	112

Tab. X-08 - Dimensions - Fan Module 05 to 10 - Backward-Curved

MODEL	A	B	C	D	E	F	G	H	J	K	L
05	1120	740	800	209	418	111	118	270	98	120	97
07	1300	850	900	279	518	111	68	325	124	150	112
10	1430	850	800	329	573	111	56	397	124	150	112

Dimensional Data

Fan Module

Fig. X - 07 - Dimensions - Fan Modules 12,5 to 30 - Backward-Curved y Forward-Curved

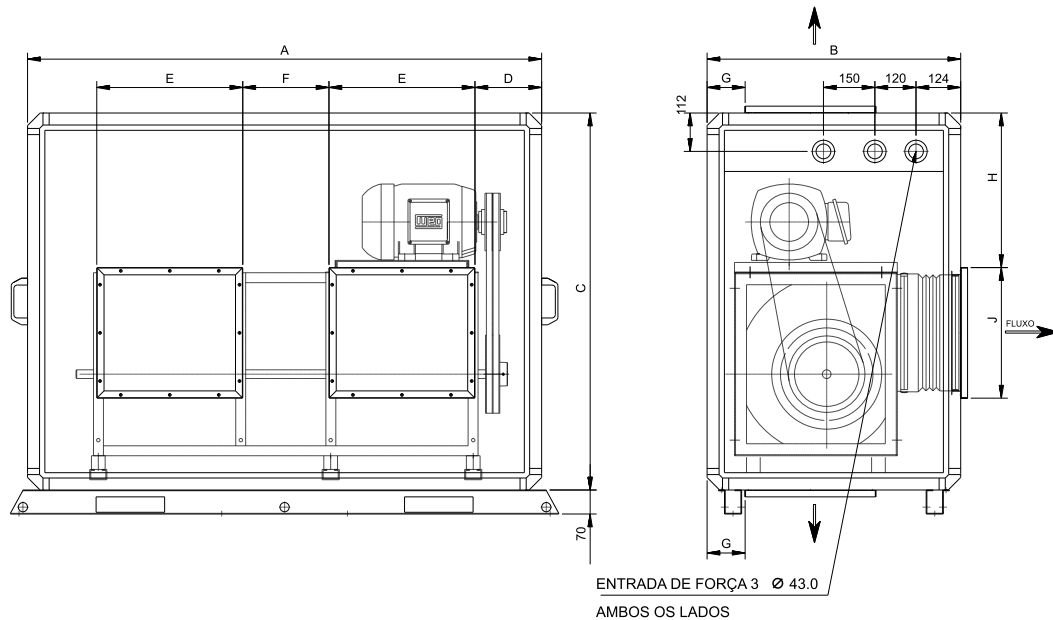

Tab. X-09 - Dimensions - Fan Modules 12,5 to 30 - Forward-Curved

MODEL	A	B	C	D	E	F	G	H	J
12,5	1500	740	1100	216,5	426	215	111	450	381
15	1500	740	1100	167,5	412	341	111	362	442
20	2000	740	1100	316,5	513	341	111	362	442
25	2400	930	1100	239,5	596	417	111	230	520
30	2770	930	1100	409,5	596	417	111	230	520

Tab. X-10 - Dimensions - Fan Modules 12,5 to 30 - Backward-Curved

MODEL	A	B	C	D	E	F	G	H	J
12,5	1500	740	1100	161,5	468	240	111	312	322
15	1700	740	1100	194	518	275	111	347	357
20	2000	800	1250	269	573	315	111	387	397
25	2400	930	1350	375,5	644	360	111	432	443
30	2770	930	1500	464,5	715	410	111	482	493
35	2770	930	1500	464,5	715	410	111	482	493
40	2770	1050	1600	359,5	795	460	111	532	543
50	2770	1050	1600	359,5	795	460	111	532	543

Dimensional Data

Fan Module

Fig. X-08 - Dimensions - Fan Modules 35/40/50 - Backward-Curved

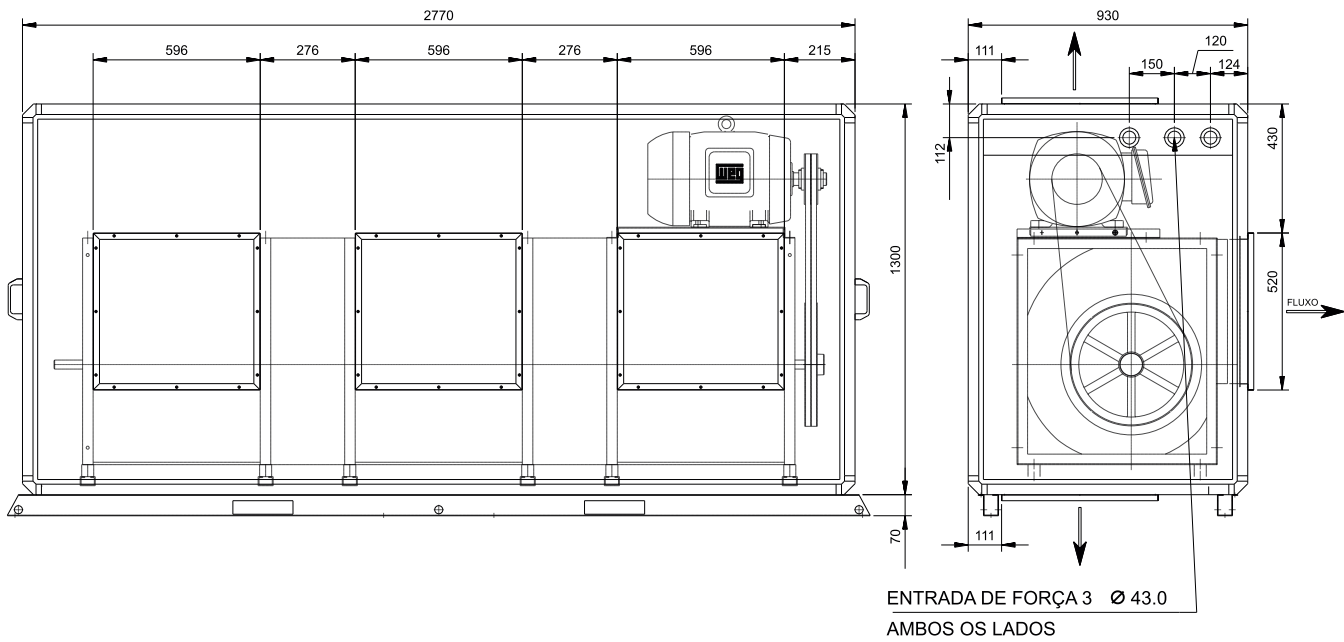

Dimensional Data

Coil Module

Fig. X-09- Dimensions - Coil Modules TRAE - 050 to 500 / TRCE - 05 to 35

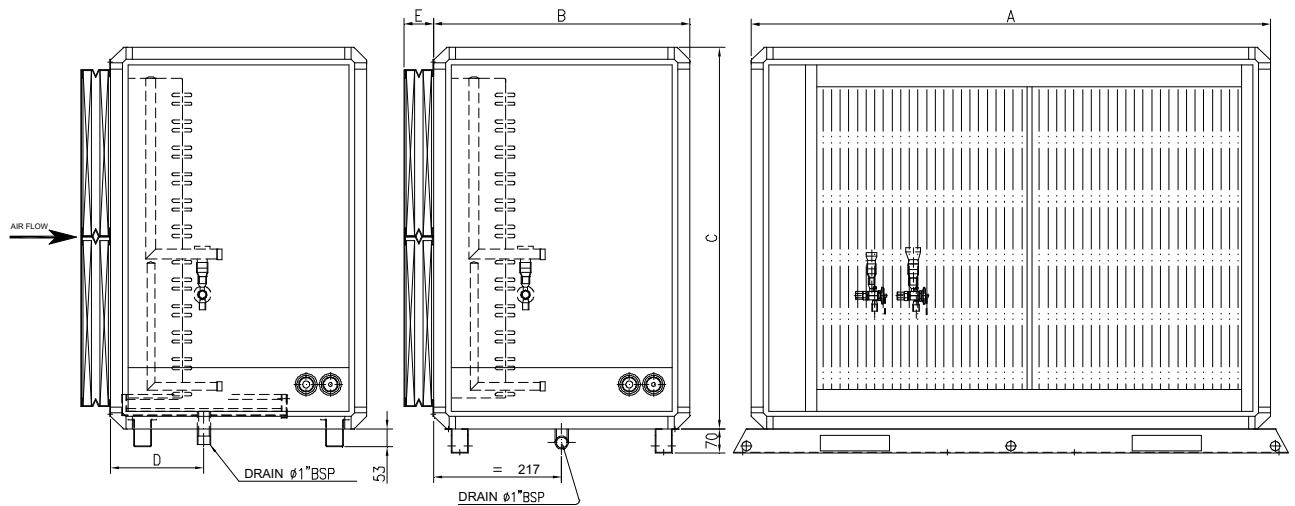

OPTIONAL MODULE ASSEMBLY FOR VERTICAL
MACHINE WITH LOW POINT DISCHARGE

Tab. X-11 - Dimensions - Coil Modules 05 to 50 - with fan module Forward-Curved 40 and 50 only TRAE

Modelo	050	075	100	125	150	200	250	300	350	400	500
A	960	1120	1430	1500	1500	2000	2400	2770	2770	2770	2770
B	580	740	740	740	740	740	930	930	930	930	930
C	660	800	800	1100	1100	1100	1100	1100	1300	1500	1680
D	205	232	232	232	232	232	232	232	232	232	232

Tab. X-12 - Dimensions - Coil Modules 05 to 50 - with fan module Backward-Curved 40 and 50 only TRAE

Modelo	050	075	100	125	150	200	250	300	350	400	500
A	1120	1300	1430	1500	1700	2000	2400	2770	2770	2770	2770
B	740	850	850	740	740	800	930	930	930	1050	1050
C	660	800	800	1100	1100	1100	1100	1100	1300	1500	1680
D	205	232	232	232	232	232	232	232	232	232	232

Tab. X-13 - Filtering stages

MODELO	FILTERING STAGES	E
05 TO 50 FOWARD-CURVED AND BACKWARD-CURVED	01 STAGE 1"	36
	02 STAGES 1" + 1"	86
	01 STAGE 2"	93
	01 STAGE 3"	143
	02 STAGES 1"+ 2"	61
	02 STAGES 1"+ 3"	110

Dimensional Data

Coil Module (Refrigerating Circuits)

Fig. X-10 - Refrigerating Circuits of Coil Modules 05 to 30

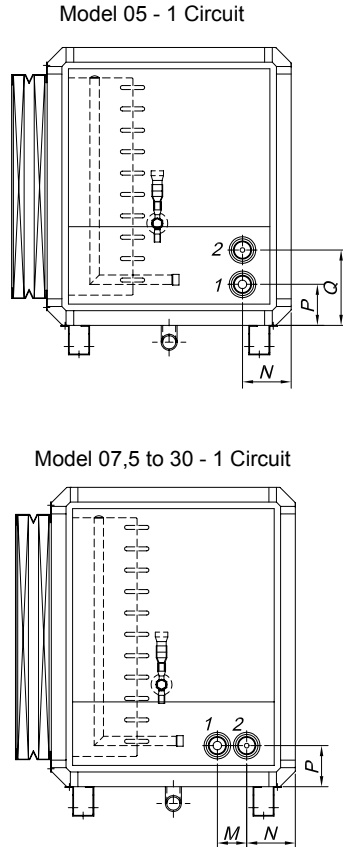

Tab. X-14 - Measures - 1 circuit

Model	05	07	10	15	20	25	30
M	-	70	80	80	80	80	80
N	98	98	98	98	98	108	108
P	110	130	123	123	123	178	147
Q	180	-	-	-	-	-	-
Φsuction 1	Φ7/8"	Φ1.1/8"	Φ1.3/8"	Φ1.5/8"	Φ1.5/8"	Φ2.1/8"	Φ2.1/8"
Φliquid 2	Φ1/2"	Φ1/2"	Φ1.5/8"	Φ7/8"	Φ7/8"	Φ1.1/8"	Φ1.1/8"
Circuit	5,0 Ton	7,0 Ton	10,0 Ton	15,0 Ton	20,0 Ton	25,0 Ton	30,0 Ton

Fig. X-11 - Refrigerating Circuits of Coil Modules 10 to 50

2 Circuits

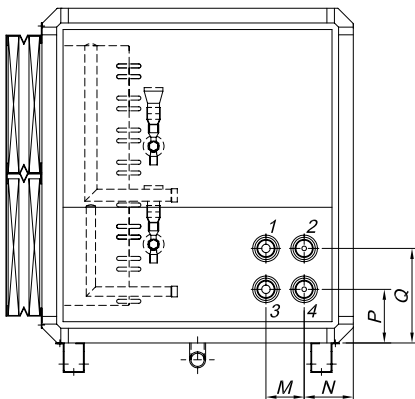

Tab. X-15 - Measures - 2 circuits

Model	10	12,5	15	20	25	30	35	40	50
M	80	80	80	80	100	100	100	100	100
N	98	98	98	98	108	108	108	108	108
P	127	127	127	112	117	117	122	122	152
Q	227	227	227	212	212	212	222	222	252
Φsuction 1	Φ7/8"	Φ1.1/8"	Φ1.1/8"	Φ1.3/8"	Φ 1.3/8"	Φ1.5/8"	Φ1.5/8"	Φ1.5/8"	Φ2.1/8"
Φliquid 2	Φ1/2"	Φ1/2"	Φ1/2"	Φ5/8"	Φ 5/8"	Φ7/8"	Φ7/8"	Φ7/8"	Φ1.1/8"
Circuit 1	5,0 Ton	7,5 Ton	7,5 Ton	10,0 Ton	12,5 Ton	15,0 Ton	20,0 Ton	20,0 Ton	25,0 Ton
Φsuction 3	Φ7/8"	Φ7/8"	Φ1.1/8"	Φ1.3/8"	Φ1.3/8"	Φ1.5/8"	Φ1.5/8"	Φ1.5/8"	Φ2.1/8"
Φliquid 4	Φ1/2"	Φ1/2"	Φ1/2"	Φ5/8"	Φ5/8"	Φ7/8"	Φ7/8"	Φ7/8"	Φ1.1/8"
Circuit 2	5,0 Ton	5,0 Ton	7,5 Ton	10,0 Ton	12,5 Ton	15,0 Ton	15,0 Ton	20,0 Ton	25,0 Ton

Dimensional Data

Assembly of Coil Module with Heating

Fig. X-12 - Assembly Details for Coil Module 05 to 50

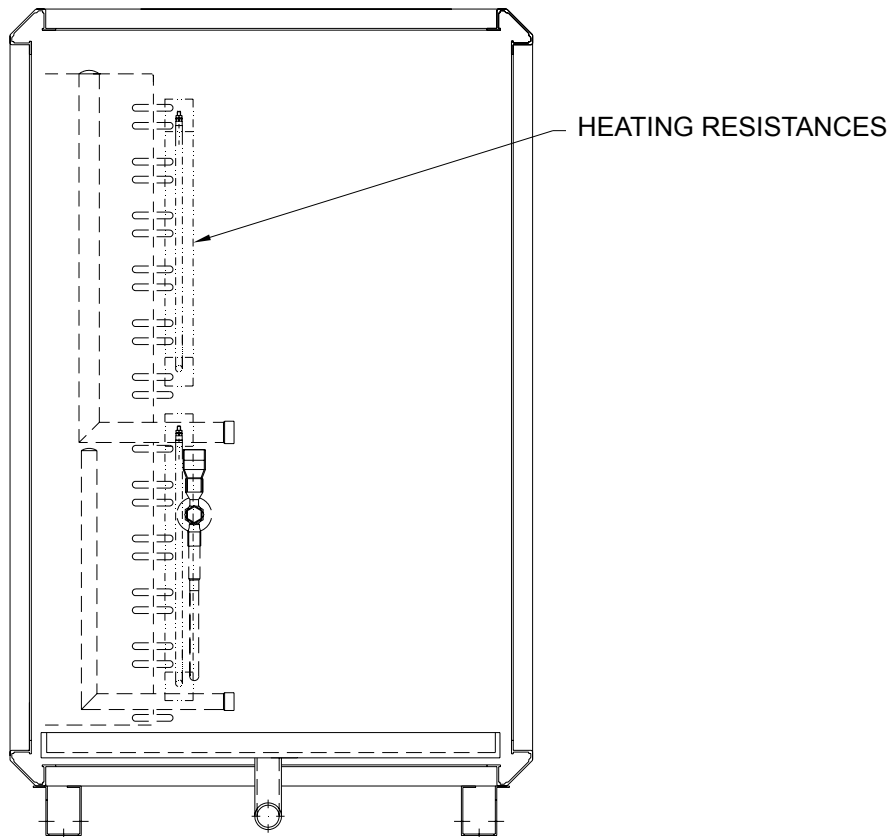

Assembly Options

Assembly A

- Cooling coil plus electrical heating without humidification tank.

Tab. X-16 - Assembly Options

Pipe Diameter	No. of Rows	Coil Module
1/2"	4	20 to 50
3/8"	4	05 to 15

Dimensional Data

Module Assembly

Fig. X-13 - Assembly of Fan and Coil Modules 05 to 50

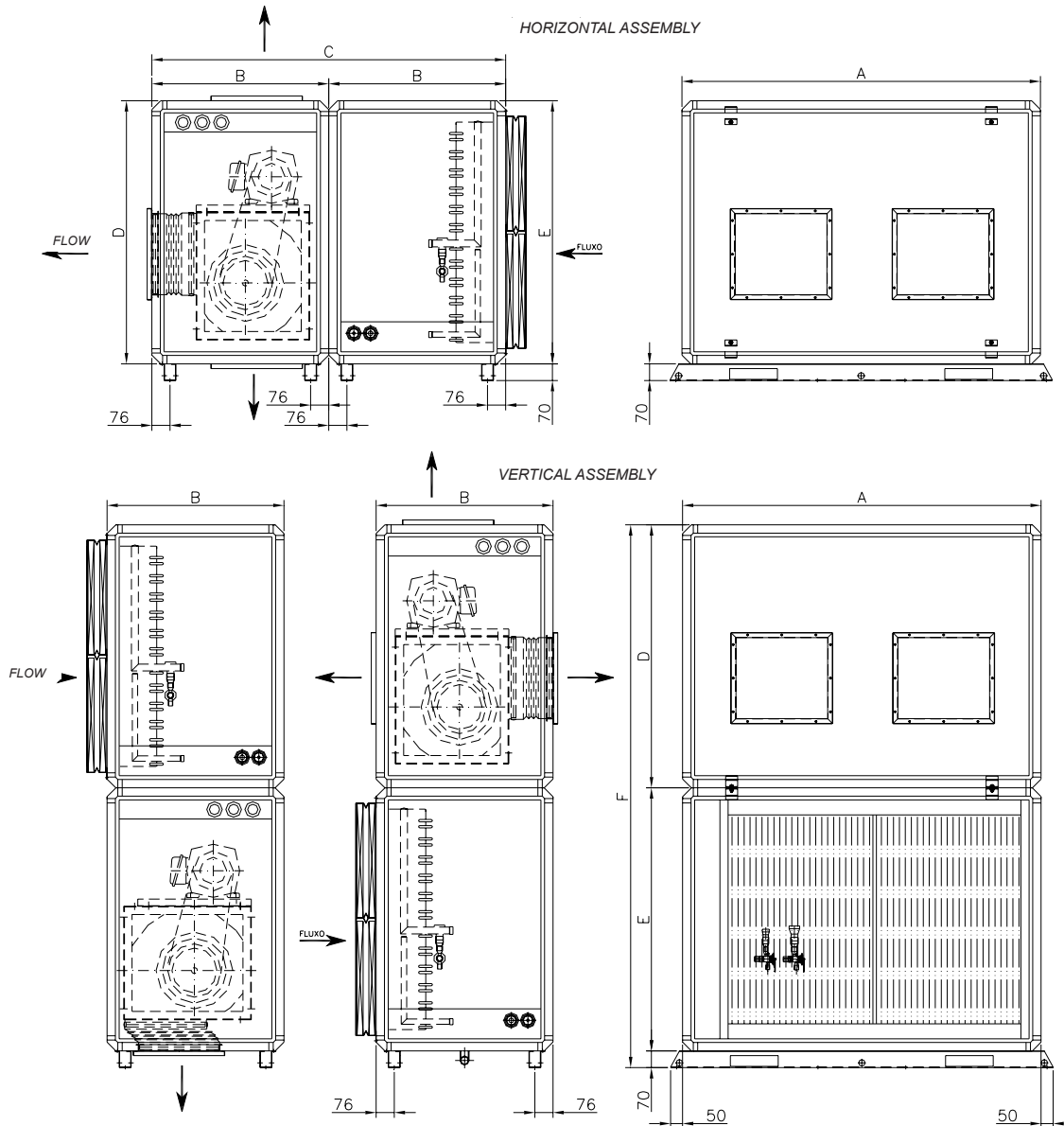

Tab. X-17 - Assembly Dimensions for Fan and Coil Modules 05 to 50 - with Forward-Curved Fan

Mod.	050	075	100	125	150	200	250	300	350	400	500
A	960	1120	1430	1500	1500	2000	2400	2770	2770	2770	2770
B	580	740	740	740	740	740	930	930	930	930	930
C	1160	1480	1480	1480	1480	1480	1860	1860	1860	1860	1860
D	660	800	800	1100	1100	1100	1100	1100	1300	1300	1300
E	660	800	800	1100	1100	1100	1100	1100	1300	1500	1680
F	1390	1670	1670	2270	2270	2270	2270	2270	2670	2870	3050

Tab. X-18 - Assembly Dimensions for Fan and Coil Modules 05 to 50 - with Backward-Curved Fan

Mod.	050	075	100	125	150	200	250	300	350	400	500
A	1120	1300	1430	1500	1700	2000	2400	2770	2770	2770	2770
B	740	850	850	740	740	800	930	930	930	1050	1050
C	1480	1700	1700	1480	1480	1600	1860	1860	1860	2100	2100
D	800	900	800	1100	1100	1250	1350	1500	1500	1600	1600
E	660	800	800	1100	1100	1100	1100	1100	1300	1500	1680
F	1530	1770	1670	2270	2270	2420	2520	2670	2870	3170	3350

Dimensional Data

Module Assembly

Fig. X-14 - Horizontal Mount 05-50 - DX / DL

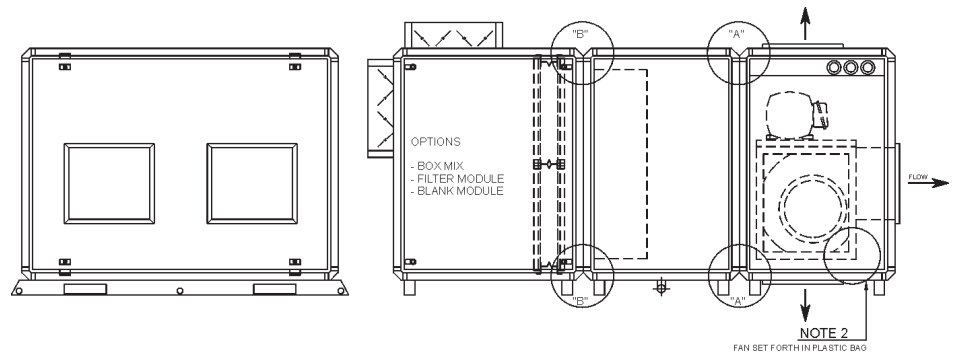
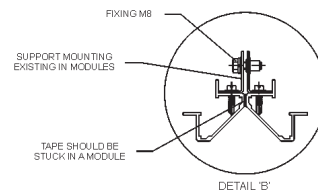
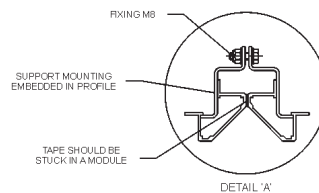
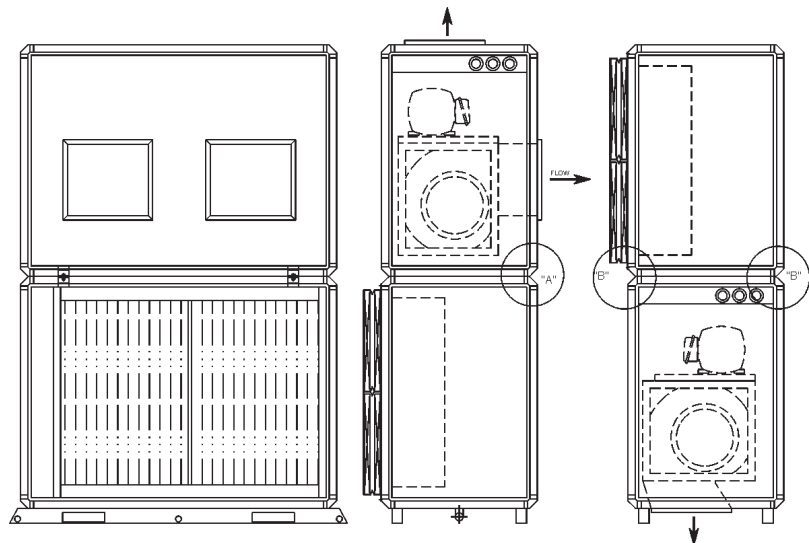

Fig. X-15 - Vertical Mount 05-50 - DX / DL



- Notes:
 1. Can not set up a vertical unit desc. Floor box for mixing.
 2. Module assembly for removing the plastic bag with fixing kit is fan within the module.

Dimensional Data

Module Assembly

Fig. X-16 – Horizontal assembly 05 to 50 – DX/DL

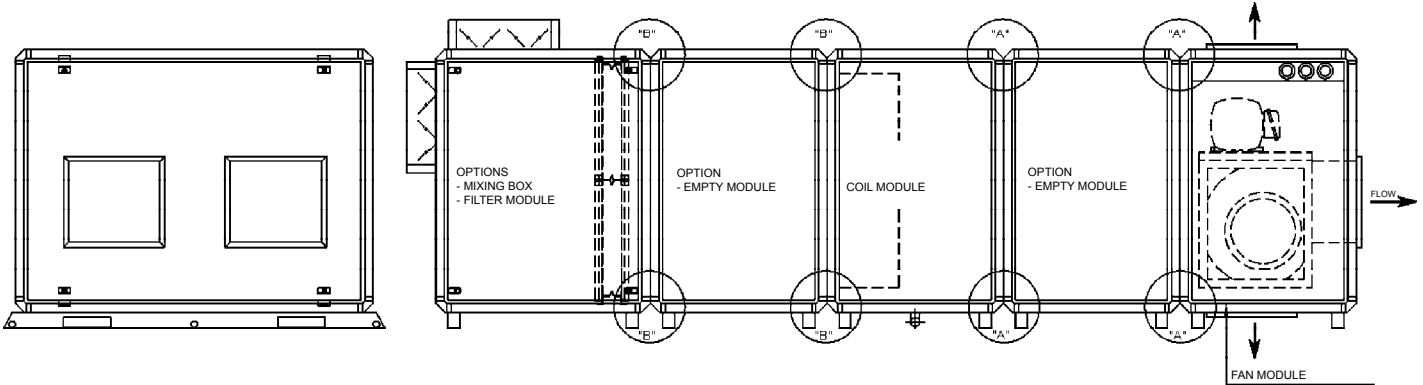

Fig. X-17 – Horizontal/vertical assembly 05 to 50 – DL (Only by design special requiring)

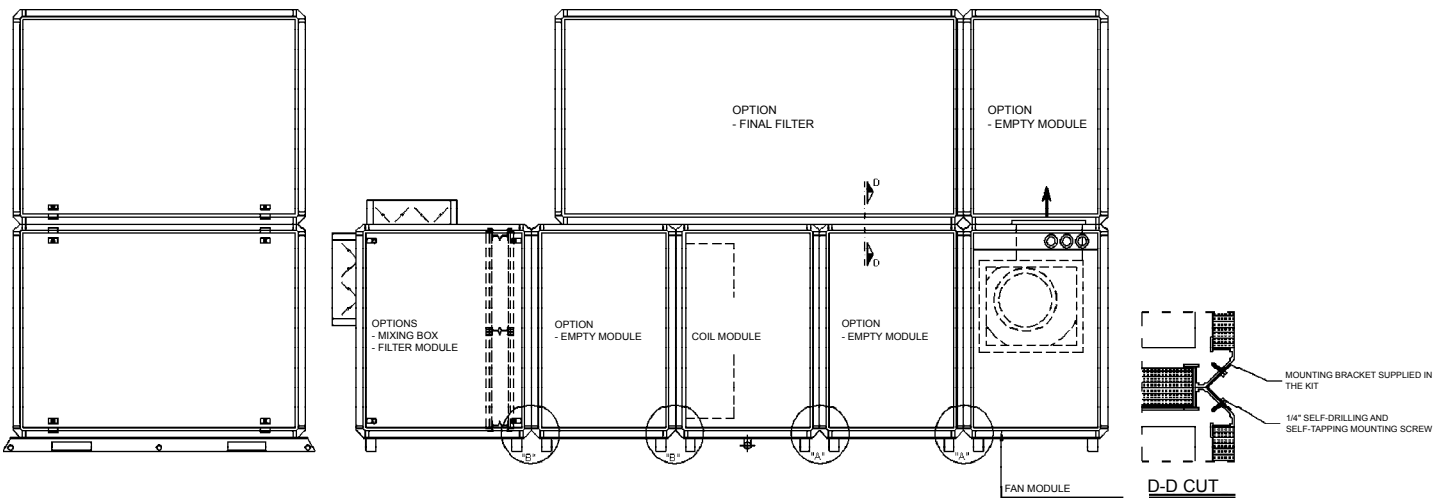
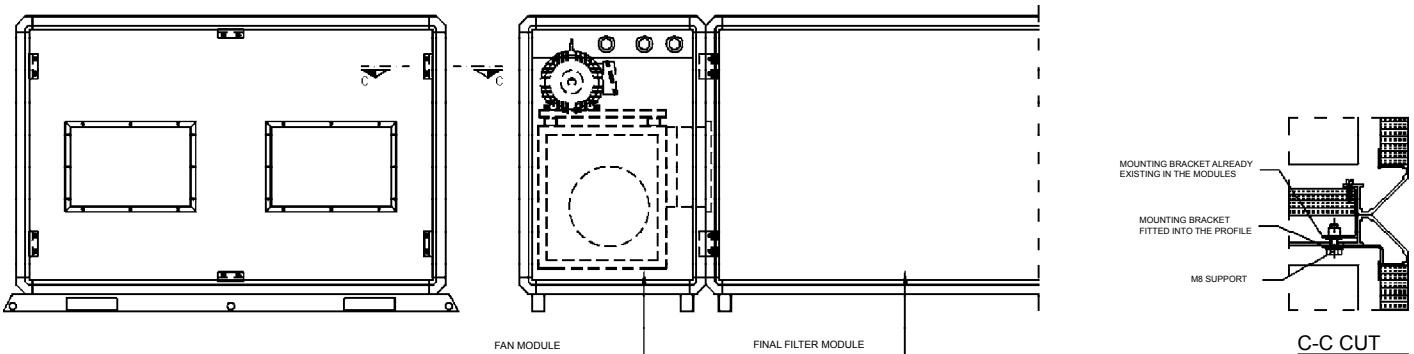

Fig. X-18 – Horizontal assembly with Final Filter



Dimensional Data

Mixing Box Module Standard

Fig. X-19 - Mixing Box Dimensions Modules 05 to 50 (1 or 2 stages of 1 "2 stage 1" + 2 "2 stage 1" + 3 ").

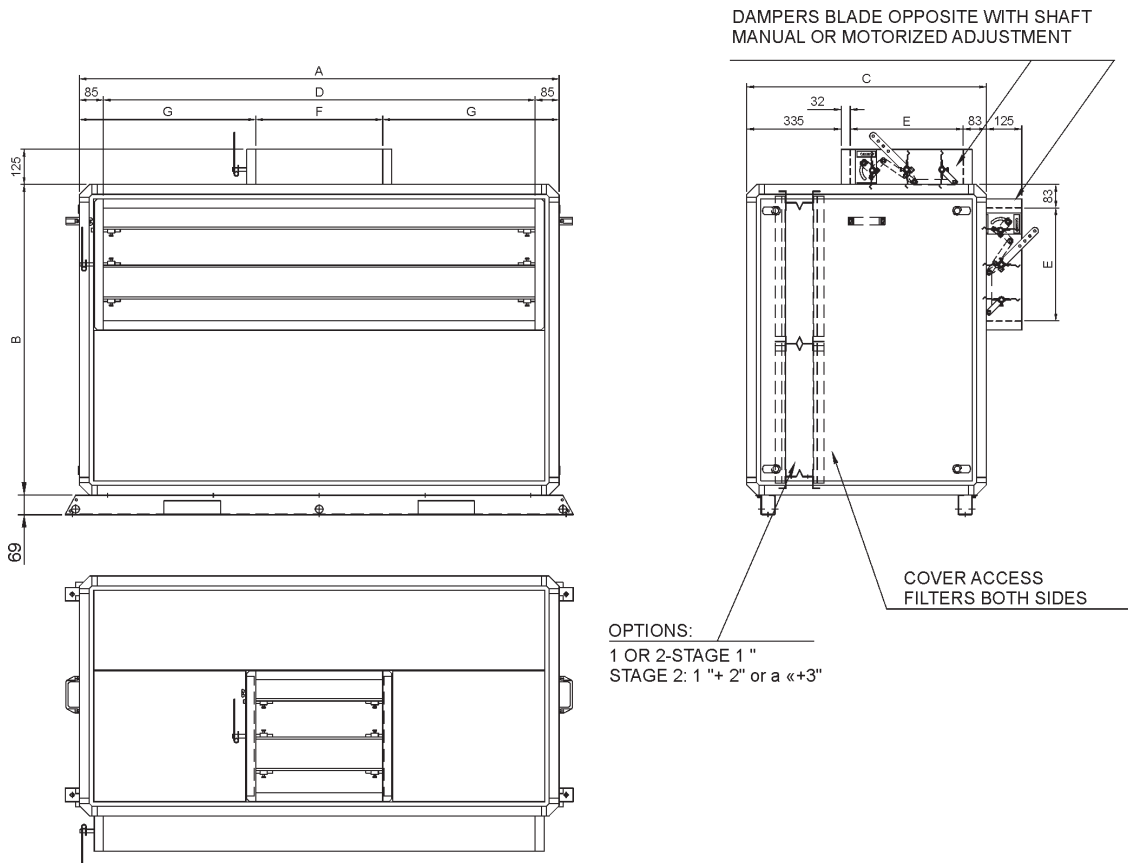

Tab. X-19 - Dimensional data box mix the DX05 DX50 - Forward-Curved

MODELO	A	B	C	D	E	F	G
05	960	660	650	790	200	200	380
07	1120	800	700	950	250	300	410
10	1430	800	750	1260	300	300	565
12	1500	1100	800	1330	350	350	575
15	1500	1100	850	1330	400	400	550
20	2000	1100	850	1830	400	450	775
25	2400	1100	850	2230	400	550	925
30	2770	1100	850	2600	400	650	1060
35	2770	1300	950	2600	500	700	1035
40	2770	1500	1000	2600	550	750	1010
50	2770	1680	1050	2600	600	800	985

Tab. X-20 - Dimensional data box mix the DL05 DL50 Limit Load - Backward-Curved

MODELO	A	B	C	D	E	F	G
05	1120	660	650	950	200	200	460
07	1300	800	700	1130	250	300	500
10	1430	800	750	1260	300	300	565
12	1500	1100	800	1330	350	350	575
15	1700	1100	850	1530	400	450	625
20	2000	1100	850	1830	400	450	775
25	2400	1100	850	2230	400	550	925
30	2770	1100	850	2600	400	650	1060
35	2770	1300	950	2600	500	700	1035
40	2770	1500	1000	2600	550	750	1010
50	2770	1680	1050	2600	600	800	985

Dimensional Data

Mixing Box Module Standard Bag

Fig. X-20 - Mixing Box Dimensions Modules 05 to 50 (2 stages: a 1" + Bag 560mm).

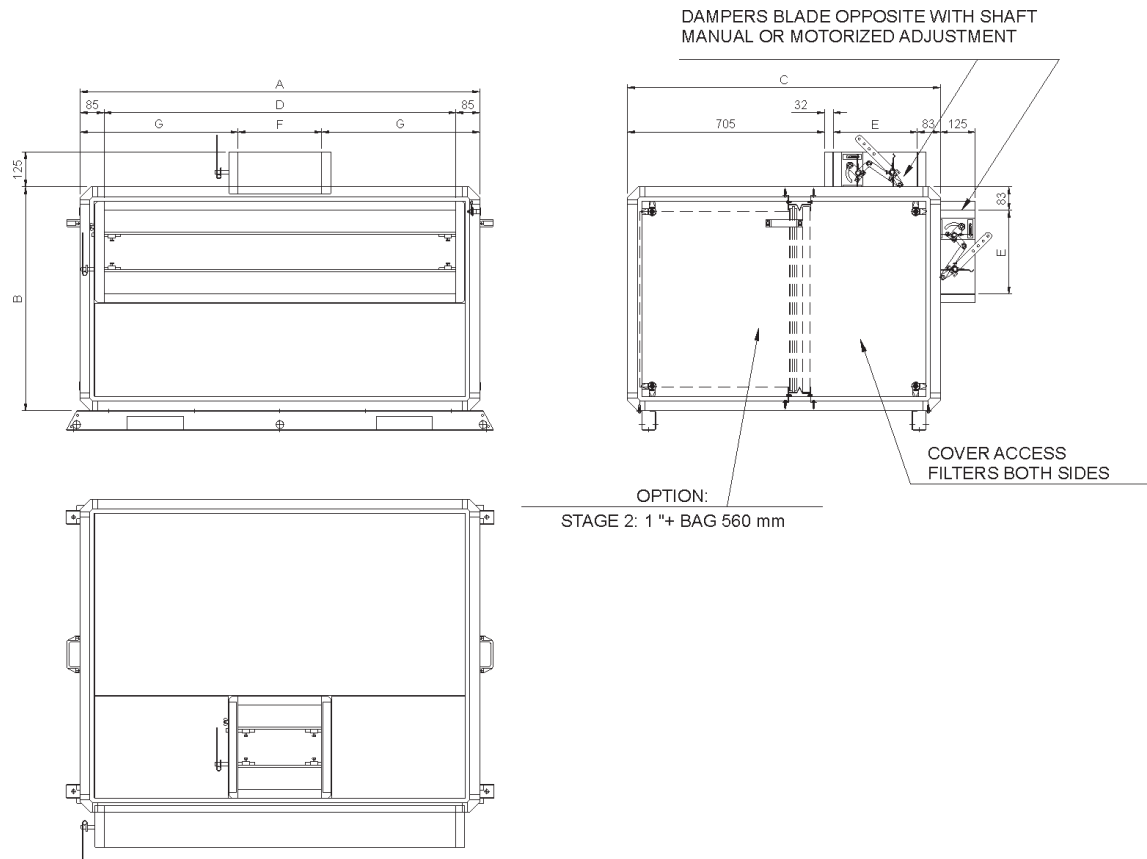

Tab. X-21 - Dimensional data box mix the DX05
DX50 - Forward-Curved

MODELO	A	B	C	D	E	F	G
05	960	660	1020	790	200	200	380
07	1120	800	1070	950	250	300	410
10	1430	800	1120	1260	300	300	565
12	1500	1100	1200	1330	350	350	575
15	1500	1100	1250	1330	400	400	550
20	2000	1100	1250	1830	400	450	775
25	2400	1100	1250	2230	400	550	925
30	2770	1100	1250	2600	400	650	1060
35	2770	1300	1380	2600	500	700	1035
40	2770	1500	1430	2600	550	750	1010
50	2770	1680	1520	2600	600	800	985

Tab. X-22 - Dimensional data box mix the DL05
DL50 Limit Load - Backward-Curved

MODELO	A	B	0	D	E	F	G
05	1120	660	1020	950	200	200	460
07	1300	800	1070	1130	250	300	500
10	1430	800	1120	1260	300	300	565
12	1500	1100	1200	1330	350	350	575
15	1700	1100	1250	1530	400	450	625
20	2000	1100	1250	1830	400	450	775
25	2400	1100	1250	2230	400	550	925
30	2770	1100	1250	2600	400	650	1060
35	2770	1300	1380	2600	500	700	1035
40	2770	1500	1430	2600	550	750	1010
50	2770	1680	1520	2600	600	800	985

Dimensional Data

Mixing Box Module Without Damper

Fig. X-21 - Mixing Box Dimensions Without the dampers 05 to 50 modules (1 or 2 stages of 1", 2 stage 1" + 2", 2 stages 1" + 3")

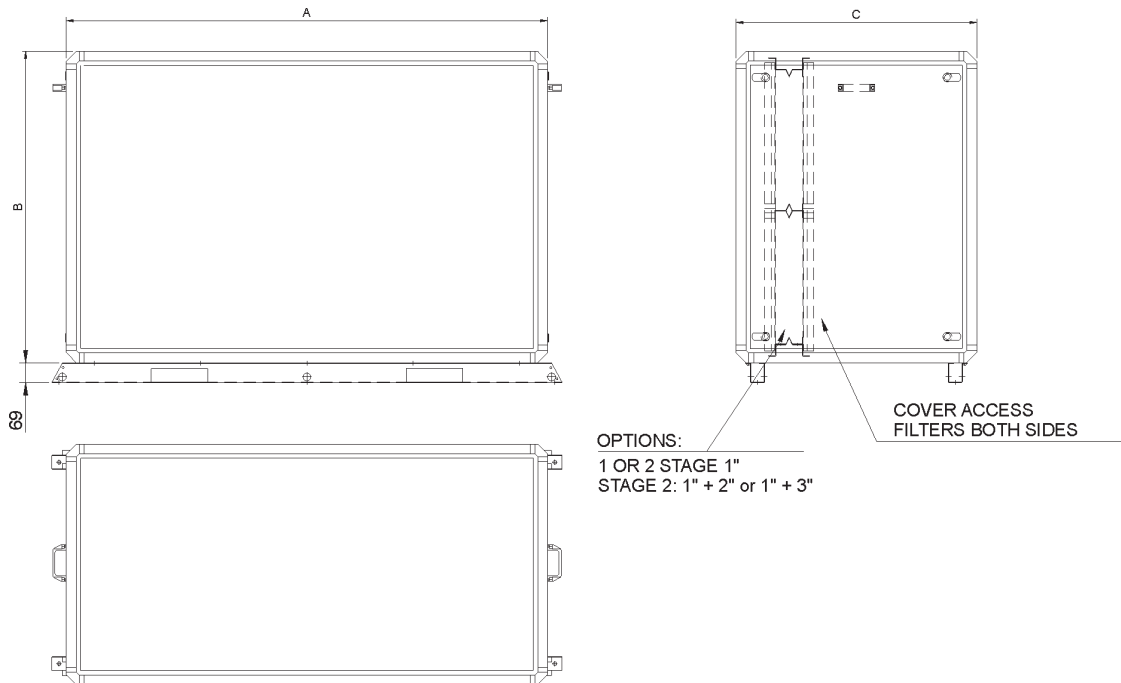

Tab. X-23 - Dimensional data box mix the DX05 DX50 - Forward-Curved

MODEL	A	B	C
05	960	660	650
07	1120	800	700
10	1430	800	750
12	1500	1100	800
15	1500	1100	850
20	2000	1100	850
25	2400	1100	850
30	2770	1100	850
35	2770	1300	950
40	2770	1500	1000
50	2770	1680	1050

Tab. X-24 - Dimensional data box mix the DL05 DL50 Limit Load - Backward-Curved

MODEL	A	B	C
05	1120	660	650
07	1300	800	700
10	1430	800	750
12	1500	1100	800
15	1700	1100	850
20	2000	1100	850
25	2400	1100	850
30	2770	1100	850
35	2770	1300	950
40	2770	1500	1000
50	2770	1680	1050

Dimensional Data

Mixing Box Module Without Damper Bag

Fig. X-22 - Mixing Box Dimensions Without Dampers Modules 05 to 50 (2 stages: 1" + Bag 560mm)

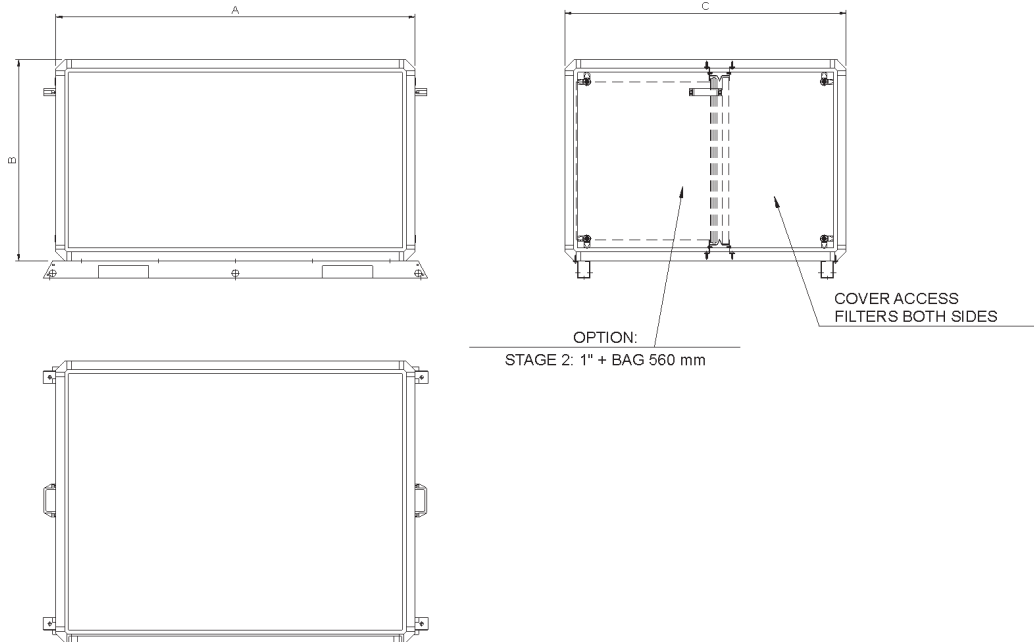

Tab. X-25 - Dimensional data box mix the DX05 DX50 - Forward-Curved

DOBLE	A	B	C
05	960	660	1020
07	1120	800	1070
10	1430	800	1120
12	1500	1100	1200
15	1500	1100	1250
20	2000	1100	1250
25	2400	1100	1250
30	2770	1100	1250
35	2770	1300	1380
40	2770	1500	1430
50	2770	1680	1520

Tab. X-26 - Dimensional data box mix the DL05 DL50 Limit Load - Backward-Curved

DOBLE	A	B	C
05	1120	660	1020
07	1300	800	1070
10	1430	800	1120
12	1500	1100	1200
15	1700	1100	1250
20	2000	1100	1250
25	2400	1100	1250
30	2770	1100	1250
35	2770	1300	1380
40	2770	1500	1430
50	2770	1680	1520

Dimensional Data

Assembly Considerations

Fans

The fan module has double inlet centrifugal fans with forward- or backward-curved blades. The fans are built in galvanized steel, with statically and dynamically balanced rotors, operating on self-aligning, self-lubricating bearings.

Discharge Option

All modules are manufactured with previous definition of vertical or horizontal assembly. Once the type is defined (H or V) it is not possible to change it in field.

The following discharge options are available for fan and coil modules:

Fig. X-23a - Discharge Options - Vertical Cabinet

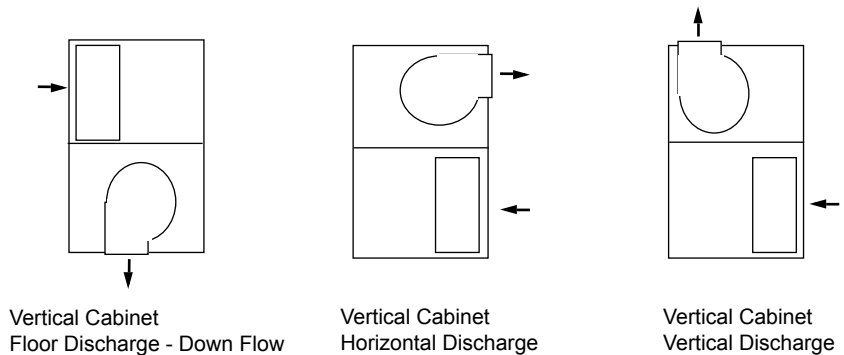
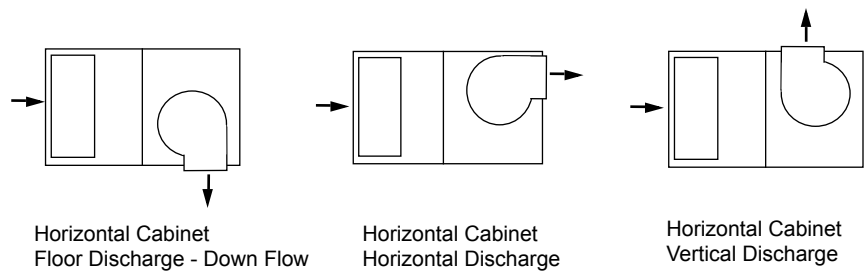

Fig. X-23b - Discharge Options - Horizontal Cabinet



Dimensional Data

TRAE

Fig. X-24 - Dimensions - Condensing Units TRAE 050 -1 circuit

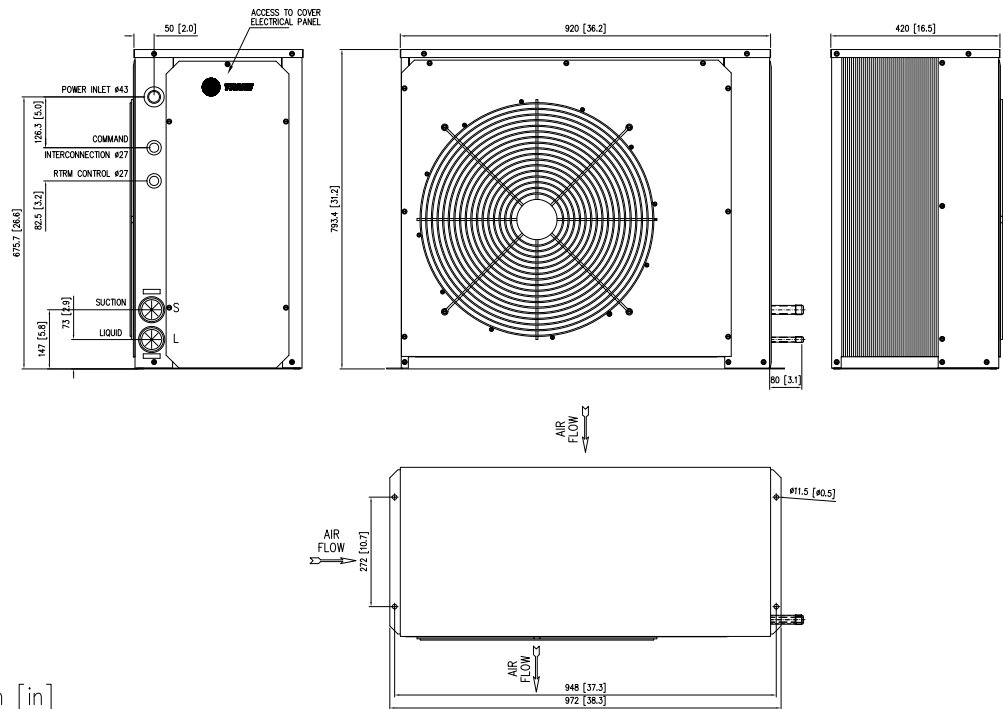

Unit: mm [in]

Fig. X-25 - Dimensions - Condensing Units TRAE 075 - 1 circuit

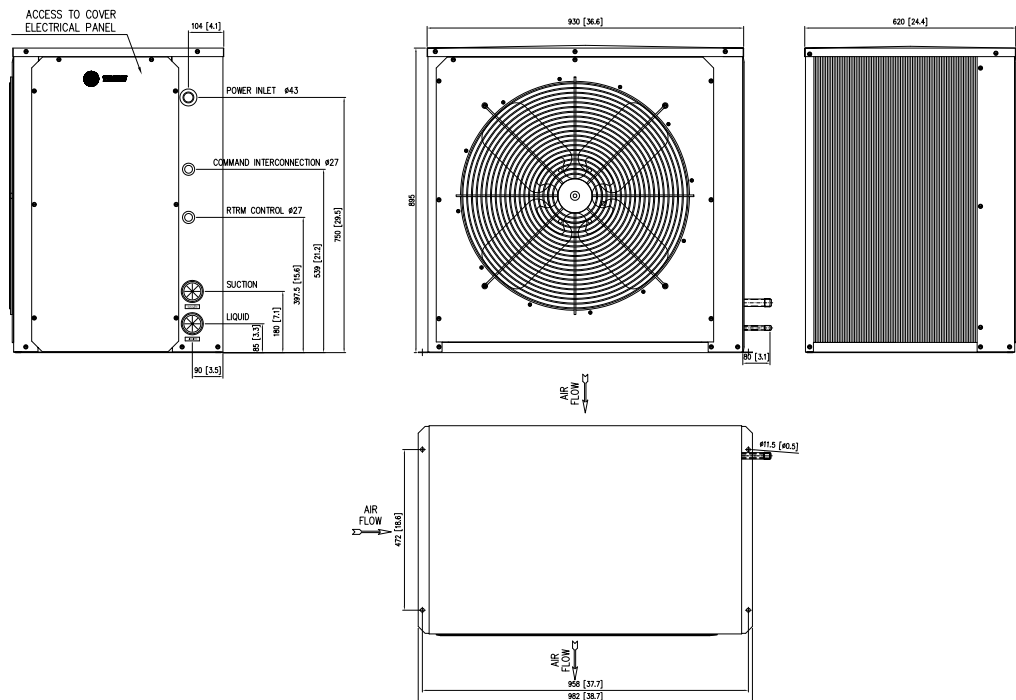

Unit: mm [in]

Dimensional Data

TRAE

Fig. X-26 - Dimensions - Condensing Units TRAE 100 - 1 circuit

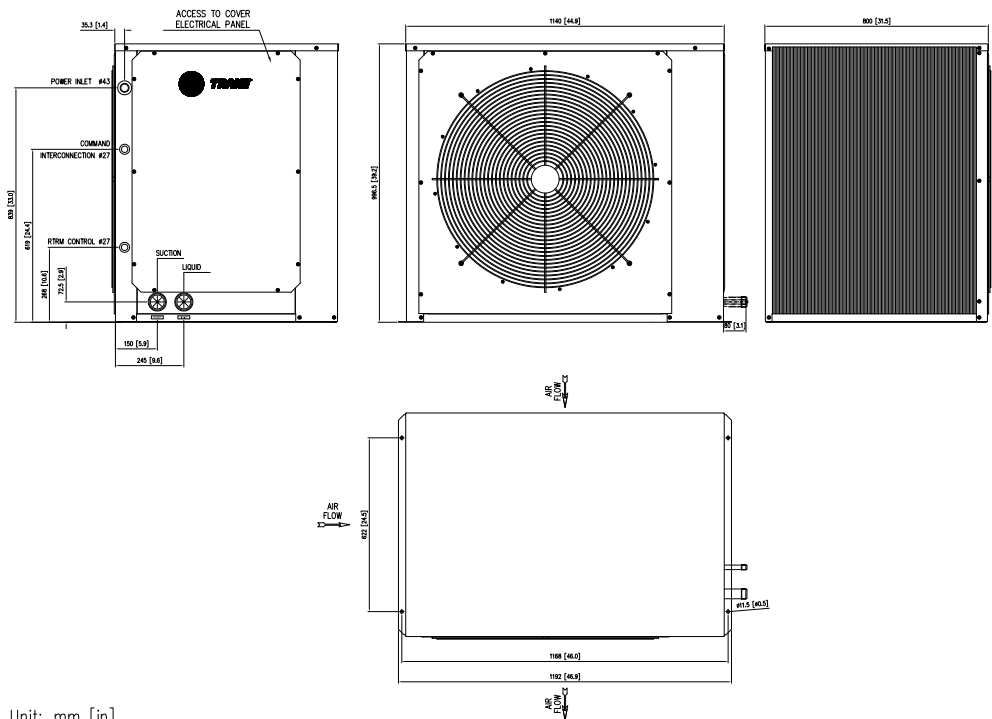

Unit: mm [in]

Fig. X-27 - Dimensions - Condensing Units TRAE 100 - 2 circuits

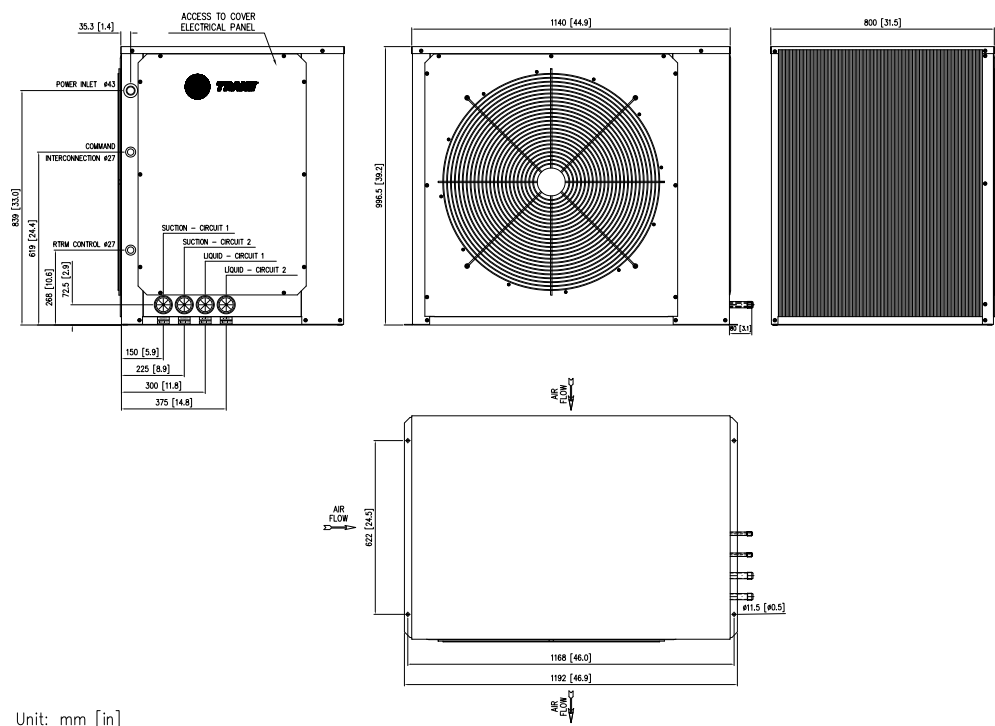

Unit: mm [in]

Dimensional Data

TRAE

Fig. X-28 - Dimensions - Condensing Units TRAE 150 - 1 circuit

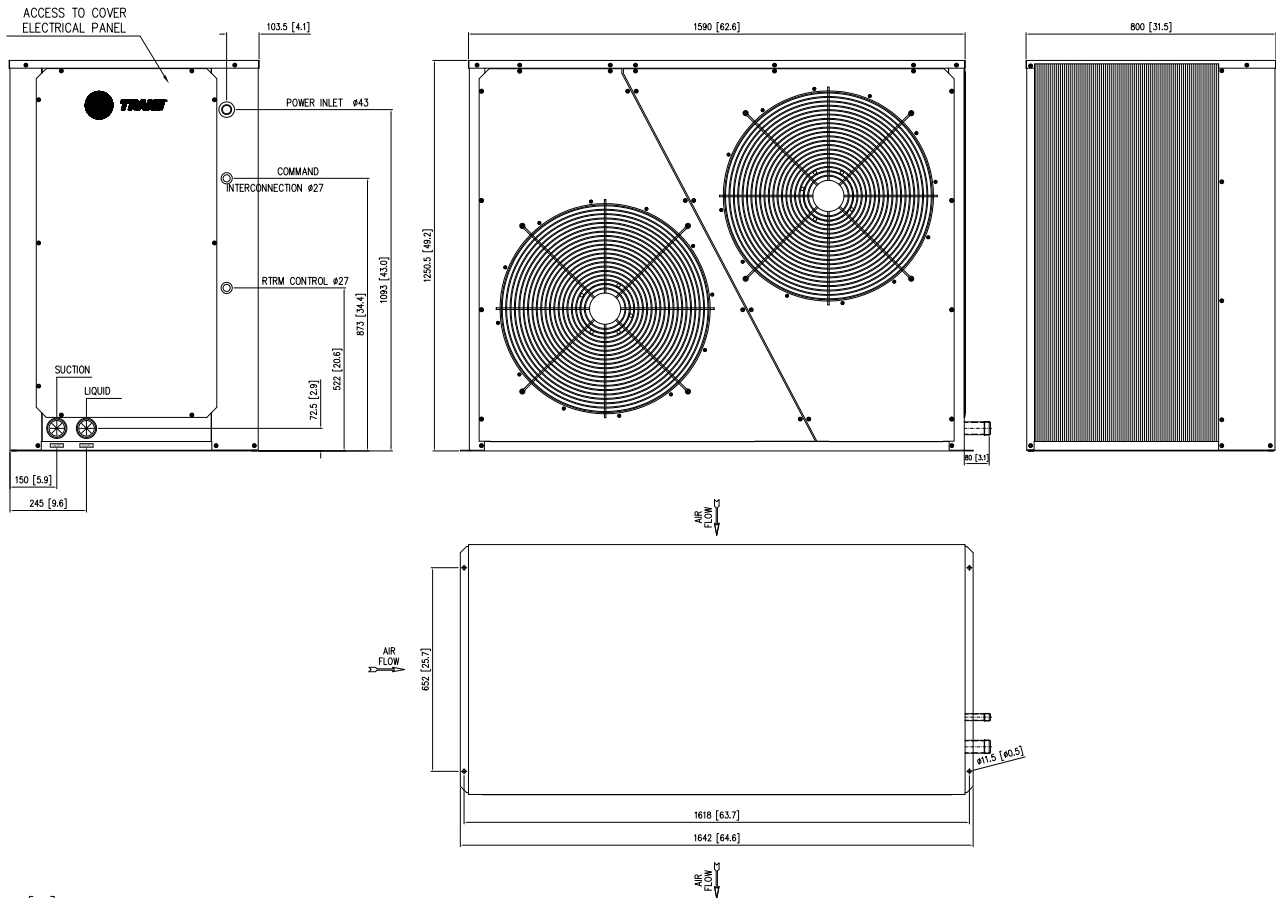

Unit: mm [in]

Dimensional Data

TRAE

Fig. X-29 - Dimensions - Condensing Units TRAE 150 - 2 circuits

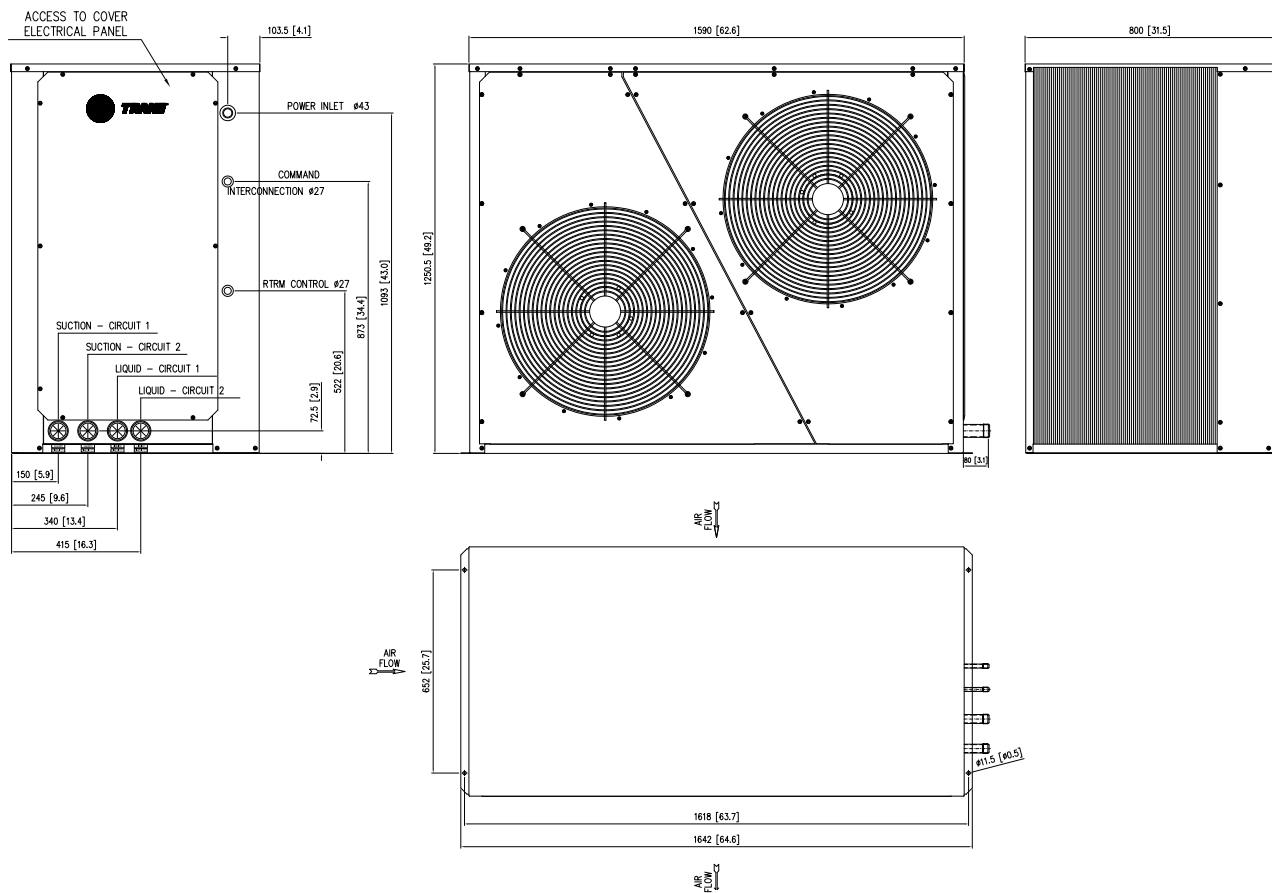

Unit: mm [in]

Dimensional Data

TRAE

Fig. X-30 - Dimensions - Condensing Units TRAE 200 - 1 Circuit

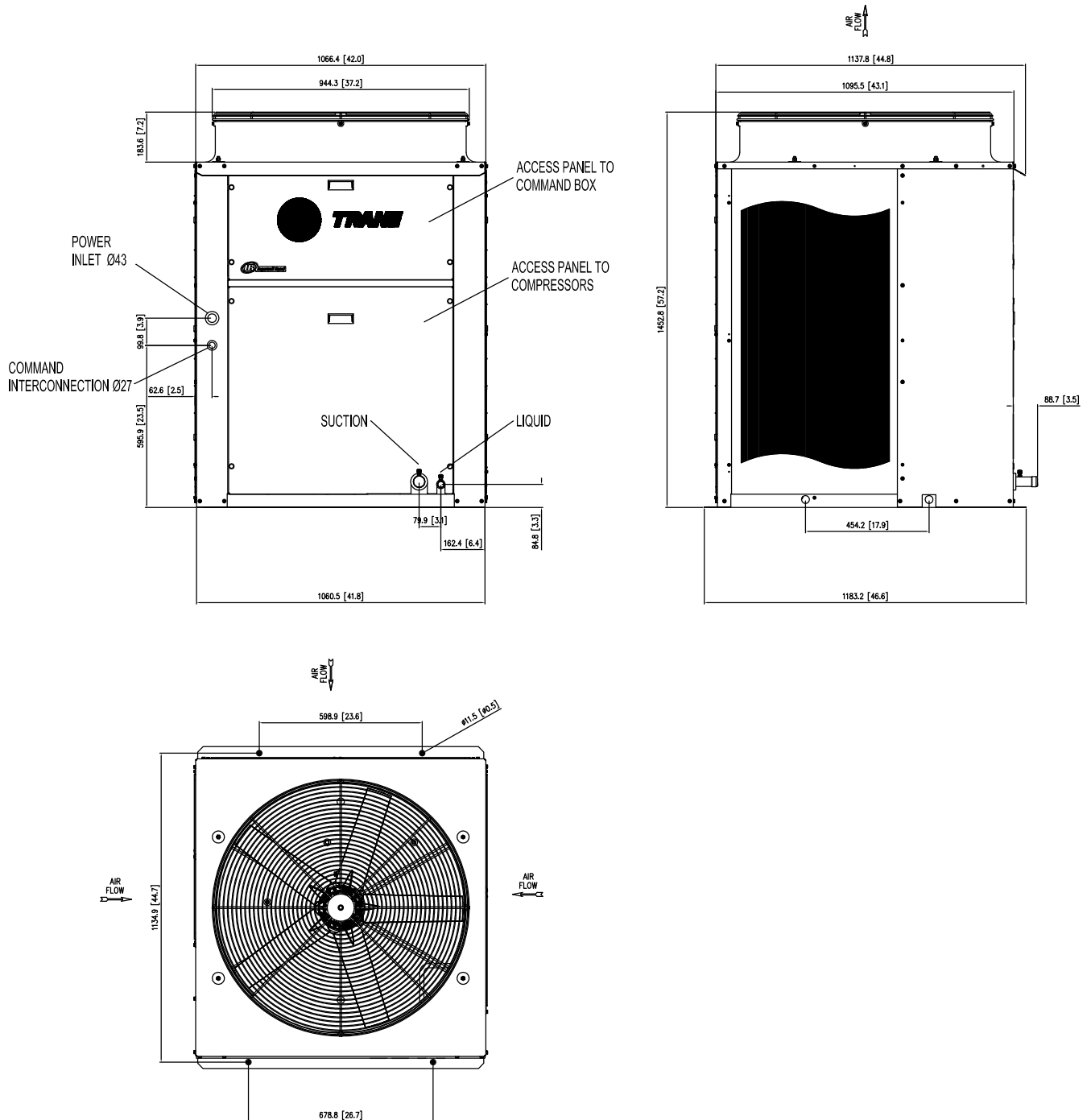

Unit: mm [in]

Dimensional Data

TRAE

Fig. X-31 - Dimensions - Condensing Units TRAE 200 - 2 Circuits

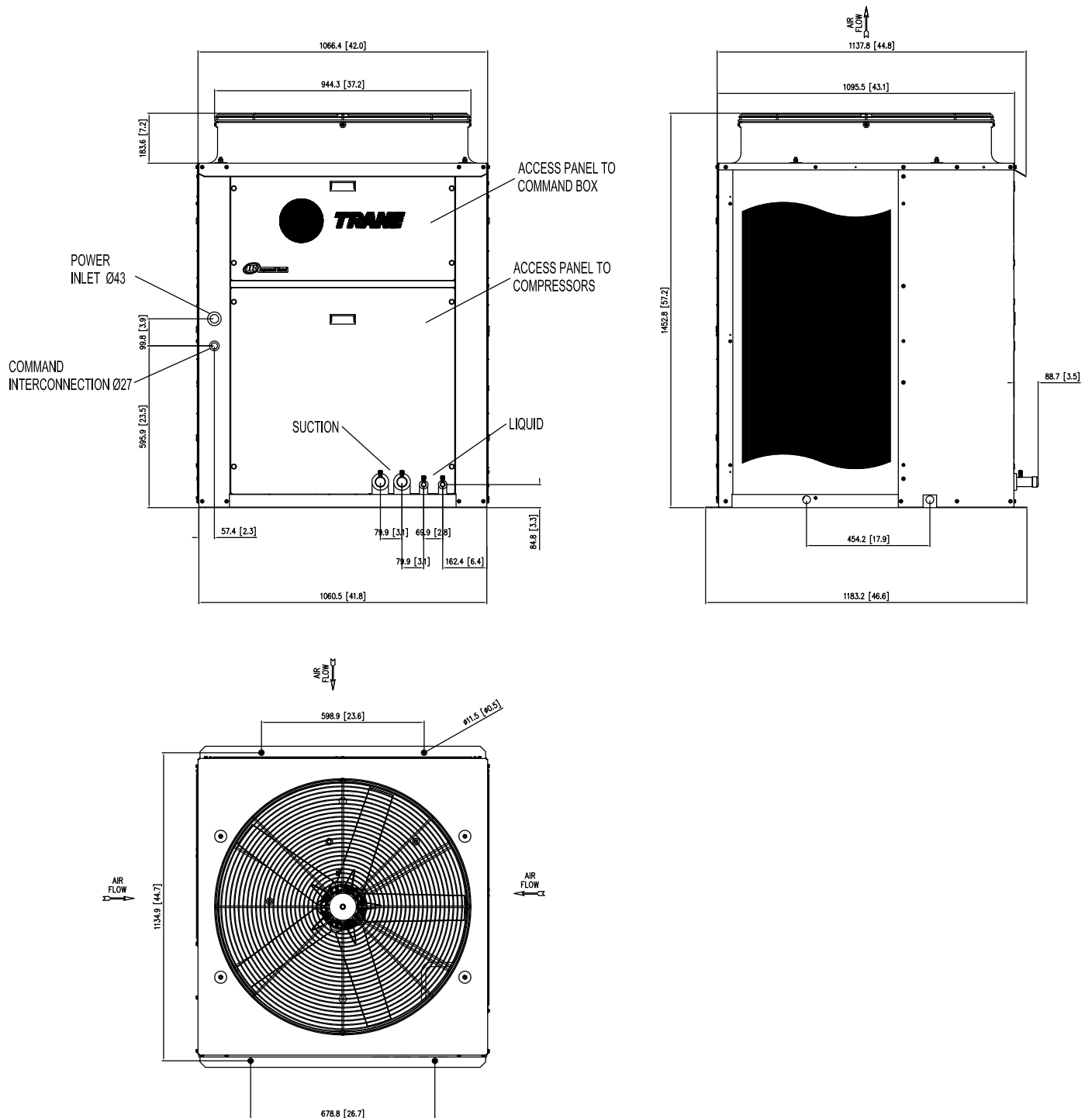

Unit: mm [in]

Dimensional Data

TRAE

Fig. X-32 - Dimensions - Condensing Units TRAE 250 - 1 Circuit

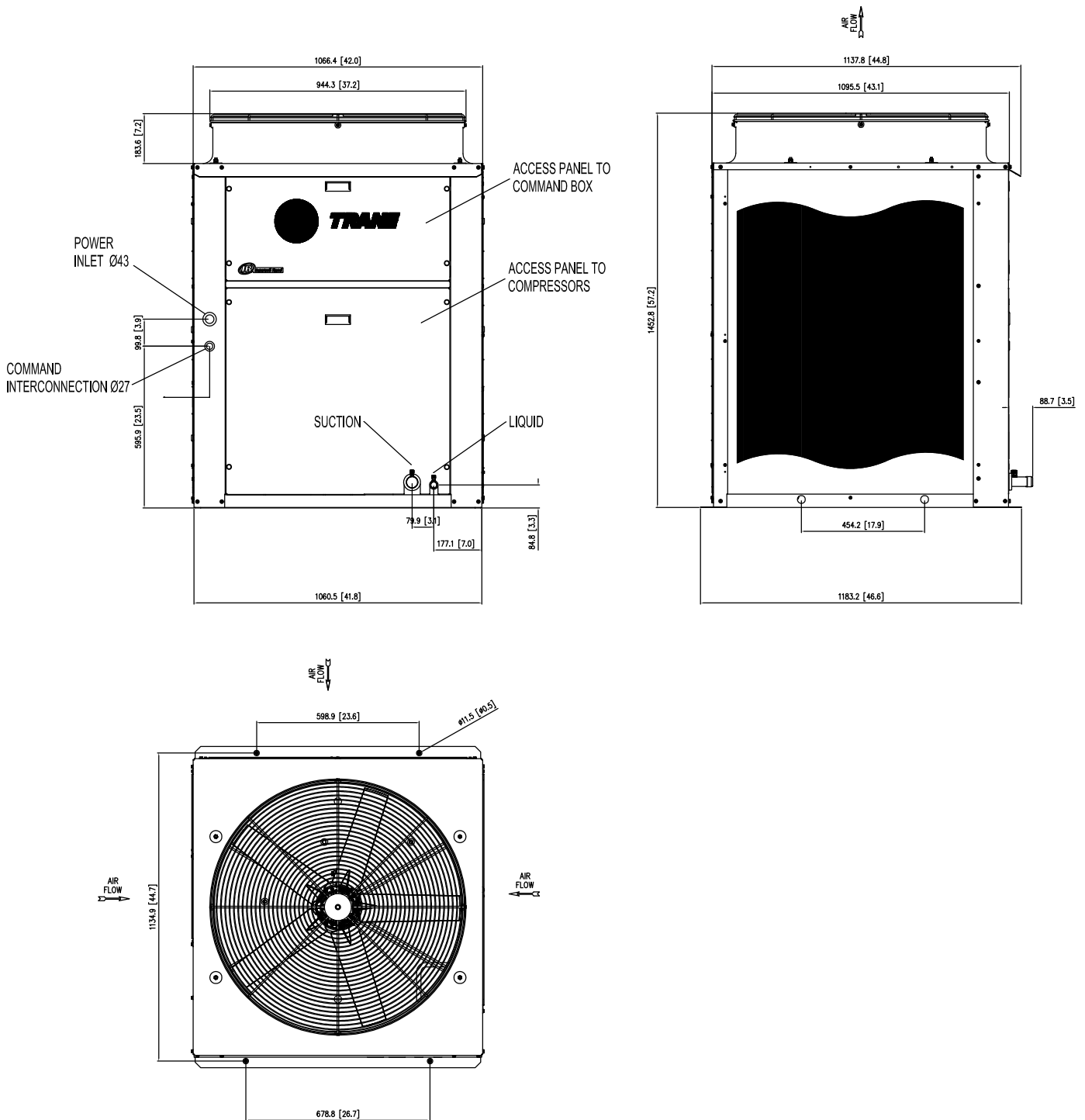

Unit: mm [in]

Dimensional Data

TRAE

Fig. X-33 - Dimensions - Condensing Units TRAE 250 - 2 Circuits

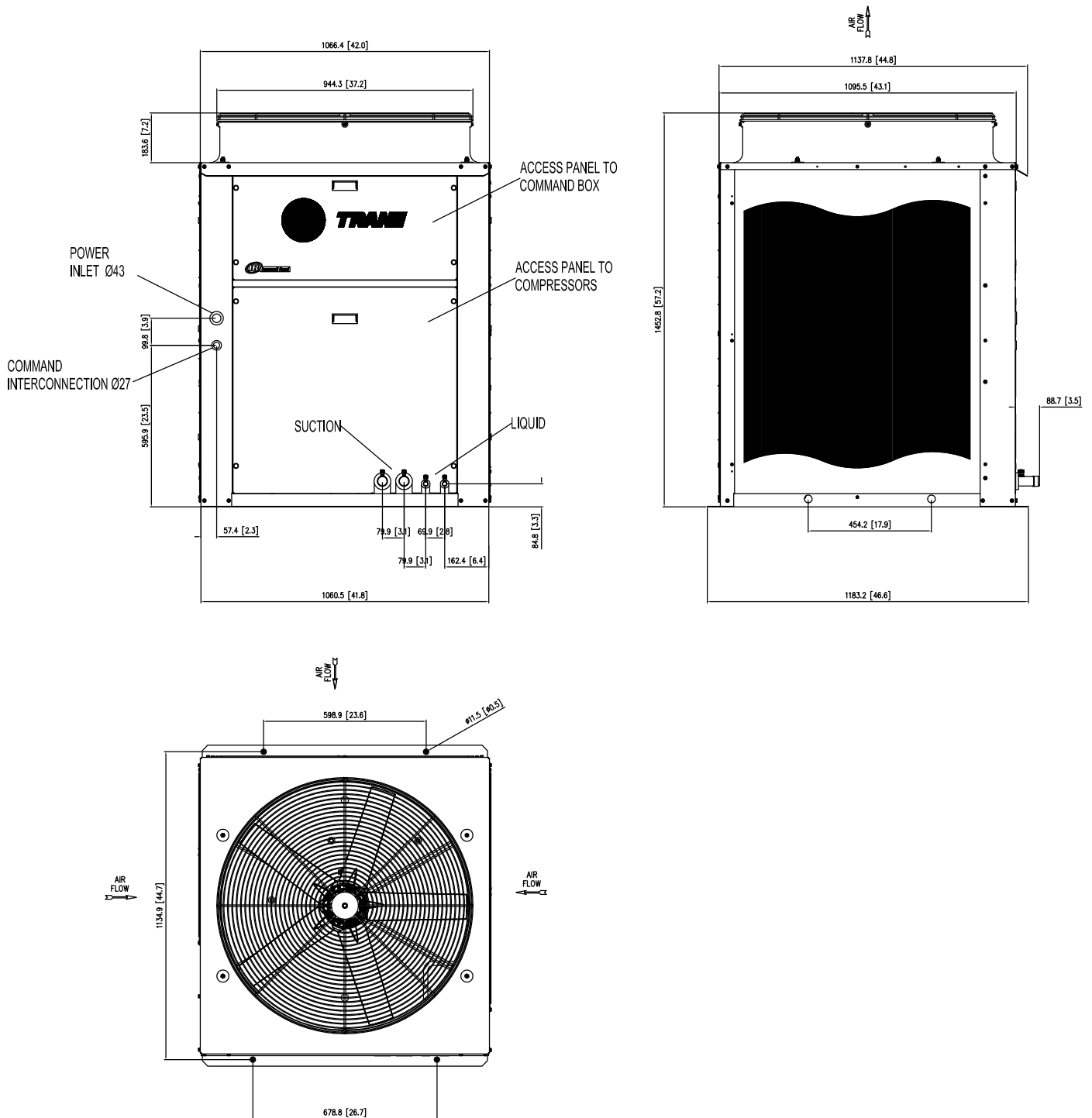

Unit: mm [in]

Dimensional Data

TRCE

Tab. X 27 - Dimensions TRCE

Cota	Modelo			
	050	075	100	150
A	922	1146	1420	1640
B	1373	1474	1525	1829
C	560	560	560	560
D	341	341	290	341
E	374	480	402	432
F	386	386	326	386
G	----	----	230	255
H	778	879	930	1234
K	813	914	965	1269
L	560	560	560	560

Fig. X 35 - Dimensions TRCE

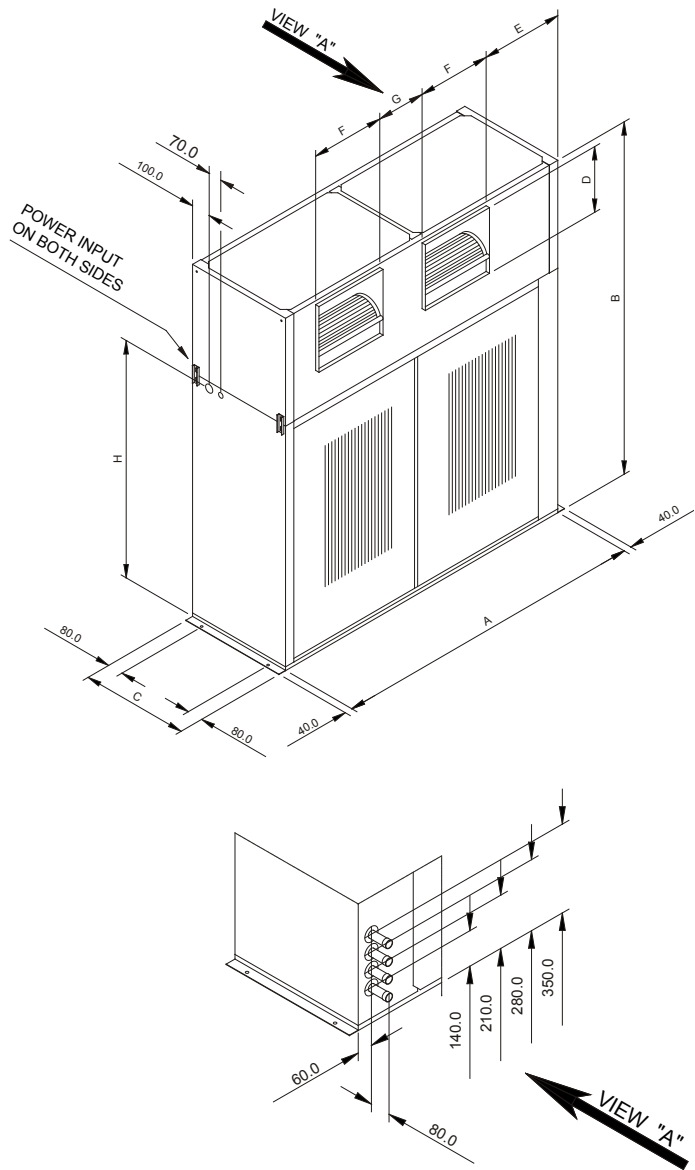
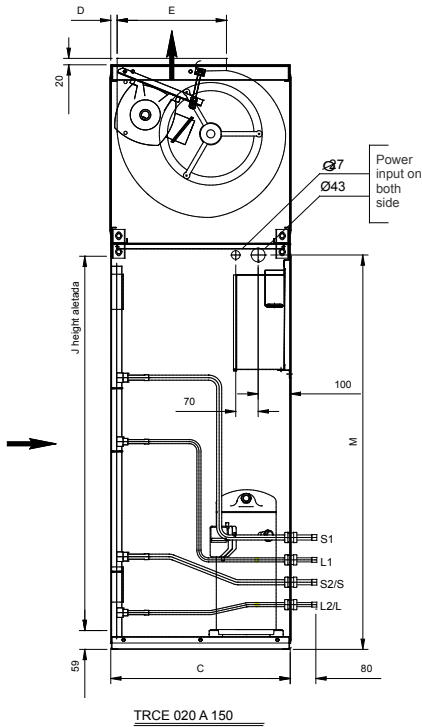

Fig. X 34 - Connections - condensing unit TRCE



TRCE 020 A 150

Tab. X-28 - Dimensions TRCE

Modelos TRCE	Medidas					
	C	D	E	J	M	
50	560	20	341	711	778	
75	560	20	341	813	879	
100C/1	560	95	290	864	930	
100C/2						
150C/1	560	20	341	1168	1234	
150C/2						

Tab. X-29 - Connection dimensions - TRCE

conexiones (pulg.)	Modelos TRCE						
	050	075	100C/1	100C/2	150C/1	150C/2	
S1	---	---	---	7/8	---	---	
S2 / S	7/8	1 1/8	1 3/8	7/8	1 5/8	1 1/8	
L1	---	---	---	1/2	---	1/2	
L2 / L	1/2	1/2	5/8	1/2	7/8	1/2	

Dimensional Application Considerations

Data TRAE / TRCE

Fig. X 36 - Clearances required for Maintenance and Air Circulation - TRAE
 Suggestes clearances TRAE 050 to 150 - Horizontal Discharge

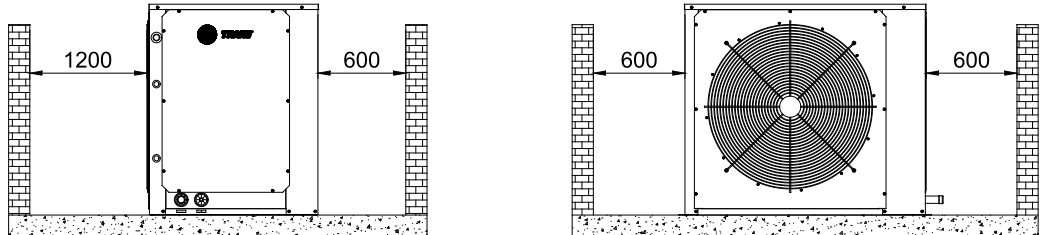

Fig. X 37 - Suggested clearances TRAE 200 to 250 - Vertical Discharge

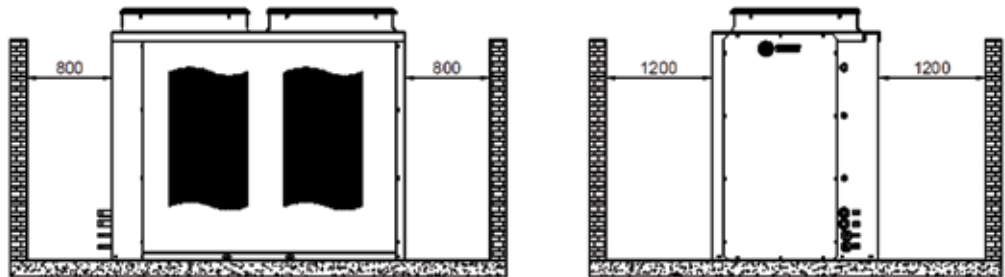
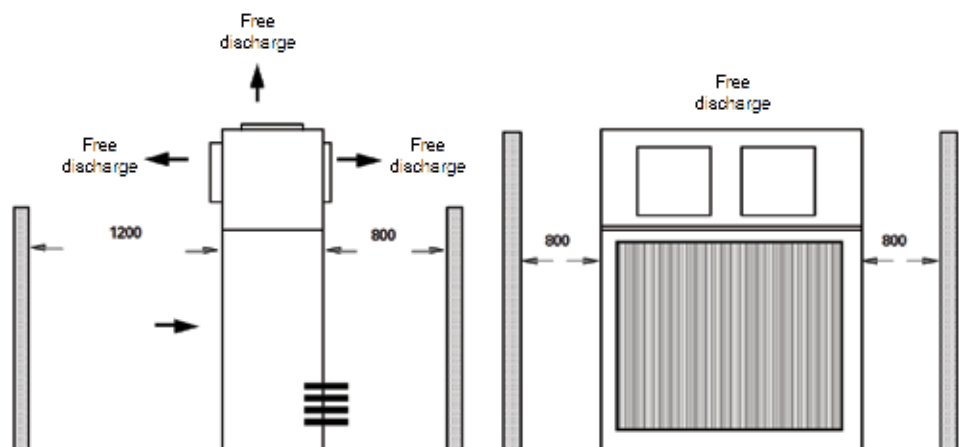

Fig. X 38 - Suggested Clearances for Maintenance and Air Circulation - Condensing Unit TRCE
 050 to 150.



XI-Controls

ReliaTel®

Solution Plus has 3 control options:

Standard Thermostat

All units are supplied with a control thermostat. This thermostat can be installed either remotely or in the equipment, according to client requirements.



Programmable Thermostat (PT)

The PT is intended for small installations with few devices. The PT has a liquid crystal display which shows the time, day of the week, selected program and room temperature. Up to 4 different setpoints can be programmed for each day of the week. Using the “timed-override” key, the user can expand the equipment operation, overriding the programmed times, as required. The main PT advantage is power savings, since devices turn on and off at programmed times.



ReliaTel® Refrigeration Module (RTRM)

Each ReliaTel® Module is a communication control. All ReliaTel units use a RTRM. It can be controlled directly by any of the following items:

- Zone Sensor Module
- Programmable Zone Sensor
- Conventional thermostat

Note:

Unlike the previous controller, a conventional thermostat **does not require** any type of interface. It can be connected directly to RTRM.



RTRM provides the primary unit control; these are its main features and benefits:

High Reliability: Less electro-mechanical components in the Electrical Panel.

Direct Digital Control : The Proportional-Integral control provides a much more accurate control of room temperature (more comfort and power consumption savings).

Test Mode: The controller allows easy and fast tests to check component operation (fans and compressors).

Easy Diagnose Detection

The operator will be able to easily detect operational problems in the unit.

Elimination of Compressor Cycling

The controller allows the compressor to be on or off for a minimum period of 3 minutes in each case, thus assuring the proper return of oil to compressor and preventing that it is blown due to excessive cycling.

Compressor Operation Sequencing

The controller will schedule the operation of compressors according to the number of starts and operation times in order to assure an equal use of all compressors.

Communication Interface Module COMM3/4 (RTCI)

Module RTCI allows the ICS (Integrated Comfort System) communication between a ReliaTel® unit and Trane ICS systems TRACER SUMMIT and TRACKER.

Communication Interface Module COMM5 (RLCI)

The RLCI module is an optional Lon-Talk (RLCI) communications interface between a ReliaTel unit and a building automation system (BAS).

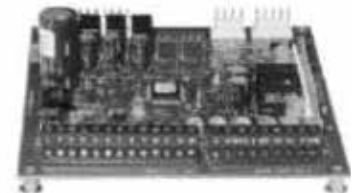

XII-Mechanical Specification

Coil Module and Fan Module Cabinet

Coil and fan module cabinets are made with galvanized steel and painted in Trane grey color. They are internally isolated with 25-mm expanded polyurethane, with an average density of 38 kg/m³. Panels are sealed with self-adhesive rubber belts.

Drip pan

Coil modules have galvanized steel drip pans which are thermally isolated by EPS and/or polyethylene. Designed to avoid water accumulation, these trays prevent fungi and bacterial growth.

Electrical Motor

Solution Plus fan module and condensing units have electrical motors with IP-21 protection level for up to 3 CV powers, and IP-55 for powers starting from 4 CV. It has class B isolation and category N. It can be supplied with 220/380/440 V.

Air filter (NBR 16401-3)

Standard coil modules have fiberglass throwaway filters, ABNT level G4. As an option, other types of filter and double filtration can be supplied.

Paint finish

Units are factory-painted in Trane gray. Parts go through a modern phosphatization process and later are powder painted with a POLYESTER resin. After this process, the parts are polymerized in an oven at 200°C, which provides them with the final resistant 85-micra coating.

Fan

Double inlet and forward-curved blades or backward-curved blades centrifugal fans. Made in galvanized steel, with statically and dynamically balanced rotor, placed on self-aligning bearings with shielded ball bearings. The fan is activated by sheaves and belts. The motor sheave is adjustable and the fan sheave is stationary. The fans are placed on galvanized steel "U" rails.

Coils

Assembled with TRANE Wavy-3B Fins. The coil is built with seamless copper tubes, mechanically expanded in the aluminum fins for perfect contact between fins and tubes. Manifolds are built with seamless copper tubes and welded to the tubes. The set is framed by galvanized steel headers in a single rigid structure. Coils undergo explosion and leaking tests.

For coil modules, models from 050 to 150, coils are built with a 3/8" diameter tube, 132 fins per foot and with a 1/2" diameter copper tube for models from 200 to 500. All of them have 4 rows and 144 fins per foot.

Start Electrical Panel

The start electrical panel is embedded to the module in a galvanized steel box. Its dimensions are as follows:

		Inbuilt Electrical Panel		
		Height	Width	Depth
Coil Module	050 to 100	350	200	161
	125 to 150	430	250	111
	200 to 500	400	250	161

Standard Thermostat

All units are supplied with a control thermostat. This thermostat can be installed remotely or in the equipment, according to the client needs.



Mechanical Specification

TRAE - Axial Fan

Condensing Unit TRAE

Developed to serve industrial and commercial markets, they have been designed to provide easy installation and maintenance and also to optimize the use of space.

Condensing units TRAE are available with 2 cabinet models. The difference between them is the air discharge type, which can be horizontal for models up to 15 Ton, and vertical for models over 20 Ton.

Cabinet

Built in galvanized steel, painted in Trane gray.



Horizontal Discharge, models 5 to 15 Ton

Paint finish

Cabinets are factory-painted in Trane gray. The parts undergo a modern phosphatization process and are later powder-painted with a POLYESTER based resin; which provides Trane equipment with high resistance. After this process, the parts are polymerized in an oven at 200°C, giving them a final resistant 85-micra coating.

Nominal Capacities

Nominal capacities for TRAE units are:

- TRAE 050 - 5,0 Ton
- TRAE 075 - 7,5 Ton
- TRAE 100 - 10,0 Ton
- TRAE 150 - 15,0 Ton
- TRAE 200 - 20,0 Ton
- TRAE 250 - 25,0 Ton



Vertical Discharge, models 20 to 25 Ton

Power Voltage

TRAE units can be supplied with 220/380/440 V power voltages, 50/60 Hz frequency, three-phases and 24-V command voltage. Optionally with command 220 V.

Air Discharge

Condensing units TRAE offer 2 types of air discharge, depending on the unit model.

For 5, 7.5, 10 and 15 Ton models, the air discharge is HORIZONTAL; for 20, 25 and models, the air discharge is VERTICAL.

Piping

Condensing units TRAE have 1/4" S NUT Schrader inspection valves in liquid, suction and discharge lines, and service valves can be specified as an option.

Mechanical Specification

TRCE - Centrifugal Fan

Condensing Unit TRCE

Condensing units TRCE basically include the following modules:

- Heat exchanger module
- Fan module

Cabinet

Built in galvanized steel, painted in Trane gray.

Paint finish

Cabinets are factory-painted in Trane gray. The parts undergo a modern phosphatization process and are later powder-painted with a POLYESTER based resin; which provides Trane equipment with high resistance. After this process, the parts are polymerized in an oven at 200°C, giving them a final resistant 85-micra coating.

Nominal Capacities

Nominal capacities for TRCE are:

- TRCE 050 - 5,0 Ton
- TRCE 075 - 7,5 Ton
- TRCE 100 - 10,0 Ton
- TRCE 150 - 15,0 Ton



Condensing Unit TRCE

Static Pressure and Filtering

As an option, units can have 2,5 mmca or 5,0 mmca static pressure, for special applications. The units can also provide a filtering system as an option for the condenser coils. The filtering options are:

- Filter Class G1 - 3 meshes
- Filter Class G2 - fiberglass.

Power Voltage

TRCE units can be supplied with 220/380/440V power voltages, 50/60 Hz frequency, three-phases and 24-V command voltage and, optionally, command 220 V.

Scroll Compressor

TRCE units are equipped with Scroll compressors.

Piping

Condensing units TRCE have 1/4" SNU Schrader inspection valves in liquid, suction and discharge lines, and service valves can be specified as an option.

Literature

Solution Plus also offers as an option the condensing unit TRCE, which is equipped with centrifugal fans. Literature about Solution Plus with condensing units TRCE can be requested specific literature at your regional office.



Scroll Compressor

Mechanical Specification

Optional

TVR LX Condensing Unit

Designed to serve commercial and industrial markets, it can be used as a main HVAD system in a construction or as a supplementary system, coordinating with an existing HVAC installation to comply with the requirements of different applications.

Cabinet

Made with cabinets of the same height and depth enabling on line installation, providing flexibility with the 8 models for combinations up to the capacity of 840MBtu/h (70 TON).

Nominal Capacities

- 4TVH0086 – 7,2 TON
- 4TVH0096 – 8,0 TON
- 4TVH0115 – 9,6 TON
- 4TVH0140 – 11,7 TON
- 4TVH0155 – 12,9 TON
- 4TVH0170 – 16,0 TON
- 4TVH0210 – 17,5 TON

Supply Voltage

TVR LX units can be supplied with 220V/60Hz y 380-415V/50-60Hz supply voltage

DC Rolling Compressor

TVR LX units are equipped with a DC rolling compressor, revolutionary asynchronous engine design using continued integrated neodymium magnets, creating a magnetic field with an additional

torque strength, dramatically increasing the efficiency at low and medium speed. Due to this technology, the engine will lay perfectly positioned allowing the compressor to have a soft start with lower amperage start.



Fan Engine

DC fan engine provides substantial improvements in operational efficiency when compared to AC conventional engines, especially during low rotation speed. In order to reach the minimum energy consumption and the best performance, it controls the speed of the DC fan according to the operating load and system pressure; it also reduces the noise level when working under part-load conditions.

Static Pressure

The highly static and adjustable fan engine, optional, is available for different applications. All units can be customized to reach an external static pressure

of 60Pa. The standard static pressure is from 0 to 20Pa.



Installation Flexibility

The mounting holes for the coolant pipes, as well as power and communication cables, are located in a variety of direction. The coolant pipes and cables can be installed at the front left or front right of the unit. This flexible design allows a more convenient installation.

Literature

For further information visit our site (www.trane.com.br) or send an email to our Marketing Department - marketing.brasil@irco.com.



Note: For further information see our TVR LX Sales Catalogue.



Mechanical Specification

Option

Coil Module and Fan Module Open Air Modules

Cabinets are prepared for outside operation, thus an enginehouse is not required. Please contact Trane do Brasil for enquiries about dimensions and configuration.

Programmable Thermostat (PT)

PT is the right choice for small installations, with few devices. PT programming is very simple. The thermostat has a liquid cristal display which exhibits the time, day of the week, selected program and room temperature. It can be programmed with up to 4 different setpoints for each day of the week. Using the timed-override key, the user can extend equipment operation times, exceeding preprogrammed schedules, if required. The main advantage of PT is energy savings, as the devices are automatically turned on and off at programmed times.

Package

Special wooden box package.

Mixing Box Module

Mixing Box is always assembled before the coil module. The Mixing Box is a box where inlet air and re-

turn air ducts can be installed. The mixing box module has dampers in galvanized steel, with opposite blades and a manual or automatic driving axis for air regulation using dampers. When **Solution Plus** is assembled with a mixing box, filters are incorporated to the box. Both sides of the box have caps to provide easy access to the filters.

Electrical Heating

Composed of tubular heating elements flat mounted on stainless steel cabinets with safety thermostat.

Heating and Electrical Panel

With a wide range of powers, reduced dimensions, protection level IP54 and technical specifications meeting IEC 60947.

Important: When electrical heating options is requested, the frames will be supplied separately, and will not be embedded in the equipment.

Controls

ReliaTel (RTRM + RTCE) micro-processed system provides several advantages and benefits for the system.

Condensing Units

Sensors

For room temperature, return air and outdoor air. Use of ReliaTel controls is required.

Coils

In applications that require high resistance against corrosion, coils can be built in copper tubes and copper fins (**copper-copper**) or with the **special protection (Yellow Fin)**.

Capacitor

For power factor correction.

Package

Special wooden box package.

Condenser pressure controller (CTCDS)

TRCE	Under request (Design Special)
TRAE*	Eletro-mechanical device that varies condensing unit fan speed.

Piping

Condensing units TRAE have, as an option, service valves in the suction, liquid and discharge lines.

Option for models TRAE200 / 250

Protection grid for the condenser coil (only TRAE200 / 250).

XIII-Weights

Tab. XII-01 - Weights - Modules Solution Plus with Forward-Curved Fan

	Motor	Fan Module Coil Module	Fan Module Coil Module Mixing Box Mod.
5 Ton	1,0	153	236
	2,0	156	239
7,5 Ton	1,5	211	311
	3,0	218	318
10 Ton	2,0	256	379
	3,0	260	383
	5,0	271	394
12,5 Ton	2,0	318	460
	3,0	322	464
	5,0	333	475
15 Ton	2,0	322	473
	3,0	326	477
	5,0	337	488
	7,5	349	500
20 Ton	2,0	426	616
	3,0	430	620
	7,5	453	643
	10,0	465	655
25Ton	3,0	673	893
	5,0	684	904
	7,5	696	916
	10,0	708	928
30 Ton	3,0	742	992
	5,0	753	1003
	7,5	765	1015
	10,0	777	1027
35Ton	5,0	871	1140
	7,5	883	1152
	10,0	895	1164
	15,0	907	1176
40 Ton	5,0	904	1187
	7,5	916	1199
	10,0	928	1211
	15,0	940	1223
50 Ton	7,5	949	1251
	10,0	961	1263
	15,0	973	1275
	20,0	1018	1320

Unit: kg

	Motor	Peso Motor	Fan Module Coil M odule	Fan Module Coil Module Mixing Box Mod.
5 Ton	2,0	15	197	291
	3,0	20	202	296
	5,0	31	213	307
7,5 Ton	2,0	15	256	366
	3,0	20	261	371
	5,0	31	272	382
10 Ton	3,0	20	260	384
	5,0	31	271	395
	7,5	43	283	407
12,5 Ton	3,0	20	330	477
	5,0	31	341	488
	10,0	58	368	515
15 Ton	5,0	31	352	516
	7,5	43	364	528
	10,0	58	379	543
20 Ton	5,0	31	454	646
	10,0	58	481	673
	15,0	74	497	689
25 Ton	7,5	43	574	796
	10,0	58	589	811
	15,0	74	605	827
	25,0	126	657	879
30 Ton	7,5	43	649	901
	10,0	58	664	916
	20,0	118	724	976
	25,0	126	732	984
35 Ton	15,0	74	710	980
	20,0	118	754	1024
	25,0	126	762	1032
40 Ton	15,0	74	939	1225
	20,0	118	983	1269
	30,0	132	997	1283
	40,0	192	1057	1343
50 Ton	15,0	74	971	1276
	20,0	118	1015	1320
	30,0	132	1029	1334
	40,0	192	1089	1394

Unit: kg

XIV-Conversion Table

To convert from:	To:	Multiply By:	To convert from:	To:	Multiply By:
Length			Velocity		
Feet (ft)	meters (m)	0,30481	Feet per minute (ft/min)	meters per second (m/s)	0,00508
Inche (in)	milimeters (mm)	25,4	Feet per second (ft/s)	meters per second (m/s)	0,3048
Area			Energy, Power and Capacity		
Square feet (ft ²)	square meters(m ²)	0,93	British Termal Units (BTU)	Kilowatt (kW)	0,000293
Square inche(in ²)	square milimeters(mm ²)	645,2	British Termal Units (BTU)	Kilocalorie (kcal)	0,252
			Tons (refrig. Effect)	Kilowatt (kW)	3,516
			Tons (refrig. Effect)	Kilocalorie per hour (kcal/h)	3024
			Horsepower (HP)	Kilowatt (kW)	0,7457
Volume			Pressão		
Cubic feet (ft ³)	cubic meters(m ³)	0,0283	Feet of water (ft.H ₂ O)	Pascal (Pa)	2990
Cubic Inches (in ³)	cubic milimeters (mm ³)	16387	Inches os water (in.H ₂ O)	Pascal (Pa)	249
Gallons (gal)	litres (L)	3,785	Pounds per square inch (PSI)	Pascal (Pa)	6895
Gallons (gal)	cubic meters (m ³)	0,003785	Pounds per square inch (PSI)	Bar ou kg/cm ²	6,895 x 10 ⁻²
Flow			Peso		
Cubic feet / min (cfm)	cubic meters / second (m ³ /s)	0,000472	Ounces (oz)	Kilograms (kg)	0,02835
Cubic feet / min (cfm)	cubic meters / hour (m ³ /h)	1,69884	Pounds (lbs)	Kilograms (kg)	0,4536
Gallons / min (GPM)	cubic meters / hour (m ³ /h)	0,2271			
Gallons / min (GPM)	litres / second (L/s)	0,06308			

Temperature			Temperature			Temperature			Temperature			Temperature		
°C	C ou F	°F	°C	C ou F	°F	°C	C ou F	°F	°C	C ou F	°F	°C	C ou F	°F
-40,0	-40	-40	-15,0	5	41	10,0	50	122	35,0	95	203	60,0	140	284
-39,4	-39	-38,2	-14,4	6	42,8	10,6	51	123,8	35,6	96	204,8	60,6	141	285,8
-38,9	-38	-36,4	-13,9	7	44,6	11,1	52	125,6	36,1	97	206,6	61,1	142	287,6
-38,3	-37	-34,6	-13,3	8	46,4	11,7	53	127,4	36,7	98	208,4	61,7	143	289,4
-37,8	-36	-32,8	-12,8	9	48,2	12,2	54	129,2	37,2	99	210,2	62,2	144	291,2
-37,2	-35	-31	-12,2	10	50	12,8	55	131	37,8	100	212	62,8	145	293
-36,7	-34	-29,2	-11,7	11	51,8	13,3	56	132,8	38,3	101	213,8	63,3	146	294,8
-36,1	-33	-27,4	-11,1	12	53,6	13,9	57	134,6	38,9	102	215,6	63,9	147	296,6
-35,6	-32	-25,6	-10,6	13	55,4	14,4	58	136,4	39,4	103	217,4	64,4	148	298,4
-35,0	-31	-23,8	-10,0	14	57,2	15,0	59	138,2	40,0	104	219,2	65,0	149	300,2
-34,4	-30	-22	-9,4	15	59	15,6	60	140	40,6	105	221	65,6	150	302
-33,9	-29	-20,2	-8,9	16	60,8	16,1	61	141,8	41,1	106	222,8	66,1	151	303,8
-33,3	-28	-18,4	-8,3	17	62,6	16,7	62	143,6	41,7	107	224,6	66,7	152	305,6
-32,8	-27	-16,6	-7,8	18	64,4	17,2	63	145,4	42,2	108	226,4	67,2	153	307,4
-32,2	-26	-14,8	-7,2	19	66,2	17,8	64	147,2	42,8	109	228,2	67,8	154	309,2
-31,7	-25	-13	-6,7	20	68	18,3	65	149	43,3	110	230	68,3	155	311
-31,1	-24	-11,2	-6,1	21	69,8	18,9	66	150,8	43,9	111	231,8	68,9	156	312,8
-30,6	-23	-9,4	-5,6	22	71,6	19,4	67	152,6	44,4	112	233,6	69,4	157	314,6
-30,0	-22	-7,6	-5,0	23	73,4	20,0	68	154,4	45,0	113	235,4	70,0	158	316,4
-29,4	-21	-5,8	-4,4	24	75,2	20,6	69	156,2	45,6	114	237,2	70,6	159	318,2
-28,9	-20	-4	-3,9	25	77	21,1	70	158	46,1	115	239	71,1	160	320
-28,3	-19	-2,2	-3,3	26	78,8	21,7	71	159,8	46,7	116	240,8	71,7	161	321,8
-27,8	-18	-0,4	-2,8	27	80,6	22,2	72	161,6	47,2	117	242,6	72,2	162	323,6
-27,2	-17	1,4	-2,2	28	82,4	22,8	73	163,4	47,8	118	244,4	72,8	163	325,4
-26,7	-16	3,2	-1,7	29	84,2	23,3	74	165,2	48,3	119	246,2	73,3	164	327,2
-26,1	-15	5	-1,1	30	86	23,9	75	167	48,9	120	248	73,9	165	329
-25,6	-14	6,8	-0,6	31	87,8	24,4	76	168,8	49,4	121	249,8	74,4	166	330,8
-25,0	-13	8,6	0,0	32	89,6	25,0	77	170,6	50,0	122	251,6	75,0	167	332,6
-24,4	-12	10,4	0,6	33	91,4	25,6	78	172,4	50,6	123	253,4	75,6	168	334,4
-23,9	-11	12,2	1,1	34	93,2	26,1	79	174,2	51,1	124	255,2	76,1	169	336,2
-23,3	-10	14	1,7	35	95	26,7	80	176	51,7	125	257	76,7	170	338
-22,8	-9	15,8	2,2	36	96,8	27,2	81	177,8	52,2	126	258,8	77,2	171	339,8
-22,2	-8	17,6	2,8	37	98,6	27,8	82	179,6	52,8	127	260,6	77,8	172	341,6
-21,7	-7	19,4	3,3	38	100,4	28,3	83	181,4	53,3	128	262,4	78,3	173	343,4
-21,1	-6	21,2	3,9	39	102,2	28,9	84	183,2	53,9	129	264,2	78,9	174	345,2
-20,6	-5	23	4,4	40	104	29,4	85	185	54,4	130	266	79,4	175	347
-20,0	-4	24,8	5,0	41	105,8	30,0	86	186,8	55,0	131	267,8	80,0	176	348,8
-19,4	-3	26,6	5,6	42	107,6	30,6	87	188,6	55,6	132	269,6	80,6	177	350,6
-18,9	-2	28,4	6,1	43	109,4	31,1	88	190,4	56,1	133	271,4	81,1	178	352,4
-18,3	-1	30,2	6,7	44	111,2	31,7	89	192,2	56,7	134	273,2	81,7	179	354,2
-17,8	0	32	7,2	45	113	32,2	90	194	57,2	135	275	82,2	180	356
-17,2	1	33,8	7,8	46	114,8	32,8	91	195,8	57,8	136	276,8	82,8	181	357,8
-16,7	2	35,6	8,3	47	116,6	33,3	92	197,6	58,3	137	278,6	83,3	182	359,6
-16,1	3	37,4	8,9	48	118,4	33,9	93	199,4	58,9	138	280,4	83,9	183	361,4
-15,6	4	39,2	9,4	49	120,2	34,4	94	201,2	59,4	139	282,2	84,4	184	363,2



Trane optimizes the performance of homes and buildings around the world. A business of Ingersoll Rand, the leader in creating and sustaining safe, comfortable and energy efficient environments, Trane offers a broad portfolio of advanced controls and HVAC systems, comprehensive building services, and parts. For more information, visit www.trane.com.br

Trane has a policy of continuous product and product data improvement and reserves the right to change design and specifications without notice.

© 2017 Trane
All rights reserved
SS-PRC002G EN February 2017
Supersedes SS-PRC002F EN November 2016

We are committed to environmentally friendly
printing practices that reduce waste.

