



*Genius e Diamond
Self Contained*

Genius

The Genius line was designed to attend to the demands of the international market from 5 to 15 TR. Constructed to offer not only the last word in internal comfort, but also in presenting reliability and ease in the installation.

The Genius with microprocessor offers the highest performance in the industry. According to IAQ standards, the micro-electronics and the simplified maintenance capacity were considered priorities in the design phase of this unit.

The Genius is the most flexible commercial use Self Contained vertical in the market. Available with a water cooled condenser (SAVE), integrated air cooling (SRVE) and with a remote air cooled condenser (SIVE/SSVE).

Water Cooled Condenser

The SAVE model with water cooled condenser includes a heat water refrigerant exchange of the shell and tube type (Shell & Tube) and tube and tube (Tube & Tube).

The R-407 refrigerant is valid only for Tube & Tube.

Remote Air Cooled Condenser.

The remote air cooled condenser models SIVE and SSVE (with a compressor in the TRCE condenser unit) and CRCB and CRCE condensers have a centrifugal fan that allows them to operate with an external static pressure drop of up to 5mm.

- CRCB: This type of condenser was developed looking for the minimum possible height dimensions.
- CRCE/TRCE: The condenser was planned looking to offer the greatest versatility possible with reference to its application. Its great differential is shown in the coil and fan in the two independent models which allows that the fan discharge be modified even in the field without any problem.

Integrated Air Cooled Condenser

The SRVE model with integrated air cooled condenser has a heat refrigerant exchange in a copper tube and aluminum fin.

Precautions against product corrosion It is recommended that air conditioning equipment shall not be installed in environments with a corrosive atmosphere such as acid or alkali gases and environments with a sea breeze. In need of installing air conditioning equipment in these areas, Trane of Brazil recommends the application of extra protection against corrosion, such as Phenolic protection or the application of ADSIL®. For more information, contact your local distributor.

Diamond

DIAMOND is the name given to our Self Contained unit with capacities that go from 20 to 40 TR, which was developed thinking about offering our clients a piece of equipment that is highly reliable, highly efficient when operating and has low levels of noise when compared with equivalent equipment. The Diamond has 5 different capacities (20, 25, 30, 35 and 40 TR) and has the option of a water cooled (SAVE) or remote air cooled (SIVE) condenser.

Water Cooled Condenser

The SAVE model with water cooled condenser includes a heat water refrigerant exchange of the shell and tube type (Shell & Tube) and tube and tube (Tube & Tube).

The R-407 refrigerant is valid only for Tube & Tube.

Remote Air Cooled Condenser.

the Self with remote air cooled condenser model SIVE has two options for a remote condenser: CRCB and CRCE that have a centrifugal fan which allows them to operate in an external static pressure drop of up to 5 mm.

- CRCB: This type of condenser was developed looking for the minimum possible height dimensions.
- CRCE: The condenser was planned looking to offer the greatest versatility possible with reference to its application. Its great differential is shown in the coil and fan in the two independent models which allows that the fan discharge be modified even in the field without any problem.

Precautions against product corrosion It is recommended that air conditioning equipment shall not be installed in environments with a corrosive atmosphere such as acid or alkali gases and environments with a sea breeze. In need of installing air conditioning equipment in these areas, Trane of Brazil recommends the application of extra protection against corrosion, such as Phenolic protection or the application of ADSIL®. For more information, contact your local distributor.



Self Contained

Scroll Compressor

It offers significant efficiency and reliable benefits. With fewer moving parts than the comparable alternative compressors, there is less internal conflict and, therefore, greater efficiency.

A smooth compressor cycle is due to the low variation in torque, creating less force on the motor resulting in greater reliability and efficiency beyond quiet operation.



Condensation Tray

The condensation tray was designed according to the ASHRAE 62-89 standard of quality for internal air which guarantees that the tray always be dry, thus avoiding the formation of fungi and bacteria.

Factory Test

The entire unit produced is tested in the factory, which guarantees a minimum occurrence of problems during the in-field start-up.

3 Filter Types (Evaporator)

To attend to commercial and industrial necessities you could choose a most adequate filter for your application:

Nylon Electrostatic Filters

Wire Mesh Permanent Filters - Metallic.

Disposable Filters - Fiberglass.

Beyond various combinations for filtering.

Command Options

Standard Thermostat

All units are supplied with a standard thermostat that could be installed remotely or directly on the equipment.

Programmable Thermostat (PT)

Programming by PT is really simple! The PT has a screen that shows the hour, day of the week, the selected program and the ambient temperature. The PT can be programmed for up to four adjustment points for each day of the week. Using the button "timed-override" for timed cancellation, the client can prolong the machine's operation beyond having a scheme programmed according to your necessities.

Controls (Reread Screen)

There are two control options:

Conventional Thermostat: This is an electromechanical system which is put into action by a thermostat which can be coupled with the unit or be remote.

Micro processor Control: The microprocessor is supplied as an option that is assembled in the factory and was designed with two main objectives: Reliability and Comfort.

The microprocessor precisely administers all of the other system operations, be it heating or cooling, as it is assembled in the factory, it will offer a smooth start that is free of problems.

The following optional items are offered:

- Yellow Fin Coil
- High Manual Reset Pressure Switch
- Service Valve.
- Liquid Display.
- Capacitor.
- High/Low Pressure Gauge.



Micro-Channel Coil

The "Micro-channel" (MCHX) coil design is based on the technology from the automotive industry. They are constructed of aluminum tubes presenting micro-channels that are mechanically soldered to the aluminum fins. It results in a better heat transfer, less dimensional, lighter and resistant to corrosion.

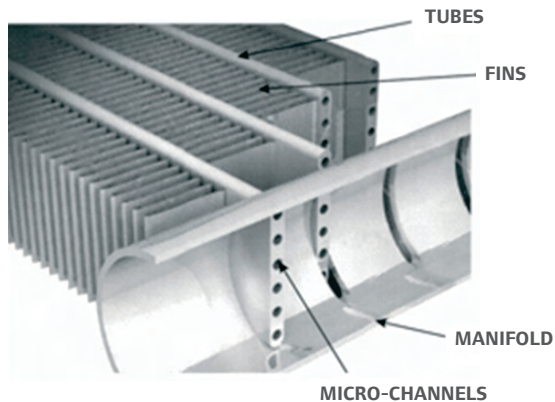

Constructive Form

The manifolds, micro-channels and fins are united in a single coil, using a nitrogen charge exchange in a furnace.

The refrigeration flow tubes are totally flat with their interior sectioned into multiple parallel channels that contain gas refrigerant.

Between the micro-channel tubes there are fins that were optimized to increase the heat transfer.

The micro-channel tubes are submerged parallel with the flat tubes connected between the two refrigerant distribution manifolds.

The coil is divided into four parts:

- The first passage is used for super heating;
- The second for discharging gas condensate;
- The third passage is the final condensate;
- The fourth is for the liquid super cooling.

MCHX x RTPF

See the advantages below in opting for a micro-channel coil in comparison with the standard coils of copper/aluminum (RTPF):

- Better refrigeration performance-analogically "MCHX", 25mm thick, is the equivalent of a standard copper/aluminum coil with 4 rows;
- Less coil weight, lower manufacturing cost and lower transport cost;
- Reduction of the gas charge in the system with 30 to 50% less charge than a conventional copper/aluminum system;
- Less manual brazing and simpler tube connection resulting in a lower leakage rate;
- More rigid coil structure due to the constructive form;
- Greater corrosive resistance to avoid the "galvanic cell" effect once we are dealing with the application of the aluminum fin with the aluminum tubes.



Ingersoll Rand develops advanced technologies that improve quality of life through integrated solutions for creating and sustaining safe, comfortable and efficient environments. Our people and our brands, including Club Car®, Ingersoll Rand®, Thermo King® and Trane®, work to provide environmental comfort and quality in homes and buildings, protect food and perishables during transport, and increase efficiency and industrial productivity.

Trane provides solutions for optimizing indoor comfort and industrial processes with an extensive portfolio of energy efficient products and systems for residences, business and industry, in addition to parts and components, building automation and services.

To know more, visit: www.ingersollrand.com and www.trane.com.br

© 2014 Trane All rights reserved
PKG-SLB002D-EN December 2014
Substitutes PKG-SLB002C-EN March 2014

We are committed to environmentally friendly printing practices that reduce waste.



Trane has a policy of continuous improvement of products and product data and reserves the right to alter designs and specifications without prior notice.