



Installation Operation Maintenance

Series R Air-Cooled Helical Rotary Liquid Chillers

RTAC Plus 140 - 350 Ton (60 Hz)

RTAC Plus 140 - 300 Ton (50 Hz)



SAFETY WARNING

Only qualified personnel should install and service the equipment. The installation, starting up, and servicing of heating, ventilating, and air-conditioning equipment can be hazardous and requires specific knowledge and training. Improperly installed, adjusted or altered equipment by an unqualified person could result in death or serious injury. When working on the equipment, observe all precautions in the literature and on the tags, stickers, and labels that are attached to the equipment.



Contents

I- Model Number	3
II-General Information	4
III-Installation Mechanical	19
IV-Installation Electrical	33
V-Operating Principles	55
VI-Controls Interface	61
VII-Diagnostics	82
VIII-Pre-Start Checkout	93
IX-Unit Start-Up Procedures	97
X-Periodic Maintenance	100
XI-Maintenance Procedures	105
XII-Wiring Diagram	113
XIII-Standard Conversion Table	137



I-Model Number

R	T	A	C	3	5	0	J	B	A	0	N	N	0	F	N	N	A	T	Y	2	N	D	C	N	N	0	N	N	1	0	N	N	0	P	N	N	0	0	0	0	N
1	2	3	4	5	6	7	8	9	10	11	12	13	14	15	16	17	18	19	20	21	22	23	24	25	26	27	28	29	30	31	32	33	34	35	36	37	38	39	40	41	42

Digits 1, 2 - Unit Model
RT = "Rotary Chiller"

Digit 3 - Unit Type
A = Air Cooled

Digit 4 - Project Sequence
C = Sequence C

Digits 5, 6 e 7 - Nominal Capacity
140 = 140 Nominal Tons
155 = 155 Nominal Tons
170 = 170 Nominal Tons
185 = 185 Nominal Tons
200 = 200 Nominal Tons
225 = 225 Nominal Tons
250 = 250 Nominal Tons
275 = 275 Nominal Tons
300 = 300 Nominal Tons
350 = 350 Nominal Tons

Digit 8 - Power Supply
C = 230/60/3
J = 380/60/3
D = 380-400/50/3
4 = 440-460/60/3

Digit 9 - Manufacturing Location
B = Curitiba Unit - Brazil

Digits 10, 11 - Minor Design Sequence
A0 - Sequence A0 (Factory Defined)

Digit 12 - Unit Basic Configuration
N = Standard efficiency/performance configuration
H = High efficiency/performance configuration

Digit 13 - Agency Listing
N = no agency listing

Digit 14 - Pressure vessel code
0 = no codification

Digit 15 - Evaporator Temperature Range
F = Standard (40-60°F)
G = Low Temp. (less than 40°F)

Digit 16 - Evaporator Config
N = Standard

Digit 17 - Condenser application
N = Standard Temp. (25-115°F)
L = Low Temp (0-115°F)

Digit 18 - Condensador Fin Material
A = Aluminun Standard
Y = Aluminum Yellow Fin

Digit 19 - Condenser Fan/Motor Configuration
T = Standard Fan with IPW55/TEAO motor
W = Low Noise Fans

Digit 20 - Compressor Starter Type
Y = Y-delta closed transition starter

Digit 21 - Incoming Power Line Connection
1 = Single point power connection
2 = Dual point power connection

Digit 22 - Power line connection type
N = Input power bar
D = Non-fused disconnect switch for incoming line
C = Circuit breaker for incoming line

Digit 23 - Unit operator interface
D = Dynaview
P = With protection box Dynaview

Digit 24 - Remote operator interface
N = w/o remote operator interface
C = Tracer Comm3 Interface
L = Comm5 - LonTalk Compatible (LCI-C) Interface

Digit 25 - Input Controls
N = w/o control
R = Ext. evaporator leaving water setpoint
C = Current Demand Control
B = External setpoint and e Current Demand Control

Digit 26 - Output Controls
N = w/o control
A = Alarme relay output
C = Output Relay Icemaking
D = Alarm relay outputs and icemaking

Digit 27 - Reserved Digit
0 = Reserved

Digit 28 - Electrical Accessories
N = w/o Accessories
E = Nema-1 Flow Switch - 150 psi

Digit 29 - Electrical Board Accessories
N = w/o Accessories

Digit 30 - Service Valve
1 = Suction Service Valve

Digit 31 - Sound attenuator
0 = w/o sound attenuator
1 = w/ sound attenuator

Digit 32 - Panel Protection
N = w/o protection
A = Total Protection Panels
C = Coil Protection Panels

Digit 33 - Installation Accessories
N = w/o installation accessories
R = Neoprene Vibration Isolators
F = Flange kit for water connections
G = Neoprene Isolator and Flange Kit

Digit 34 - Reserved Digit
0 = Reserved

Digit 35 - Language - Literature/Stickers
P = Portuguese/Spanish

Digit 36 - Shipping Facility Accessories
0 = Reserved

Digit 37 - Security Devices
N = Standard

Digit 38 - Reserved Digit
0 = Reserved

Digit 39 - Reserved Digit
0 = Reserved

Digit 40 - Reserved Digit
0 = Reserved

Digit 41 - Reserved Digit
0 = Reserved

Digit 42 - Product Type
N = Standard
Z = Special



II-General Information

NOTICE: Warnings and Cautions appear at appropriate sections throughout this literature. Read these carefully.

WARNING: Indicates a potentially hazardous situation which, if not avoided, could result in death or serious injury.

CAUTION: Indicates a potentially hazardous situation which, if not avoided, may result in minor or moderate injury. It may also be used to alert against unsafe practices.

CAUTION: Indicates a situation that may result in equipment or property-damage only accidents.

Important

Environmental Concerns!

Scientific research has shown that certain man-made chemicals can affect the earth's naturally occurring stratospheric ozone layer when released to the atmosphere. In particular, several of the identified chemicals that may affect the ozone layer are refrigerants that contain Chlorine, Fluorine and Carbon (CFCs) and those containing Hydrogen, Chlorine, Fluorine and Carbon (HCFCs). Not all refrigerants containing these compounds have the same potential impact to the environment. Trane advocates the responsible handling of all refrigerants-including industry replacements for CFCs such as and HCFCs and HFCs.

Responsible Refrigerant Practices!

Trane believes that responsible refrigerant practices are important to the environment, our customers, and the air conditioning industry. All technicians who handle refrigerants must be certified. The Federal Clean Air Act (Section 608) sets forth the requirements for handling, reclaiming, recovering and recycling of certain refrigerants and the equipment that is used in these service procedures. In addition, some states or municipalities may have additional requirements that must also be adhered to for responsible management of refrigerants. Know the

applicable laws and follow them.

WARNING

Contains Refrigerant!

System contains oil and refrigerant under high pressure. Recover refrigerant to relieve pressure before opening the system. See unit nameplate for refrigerant type. Do not use non-approved refrigerants, refrigerant substitutes, or refrigerant additives.

Failure to follow proper procedures or the use of non-approved refrigerants, refrigerant substitutes, or refrigerant additives could result in death or serious injury or equipment damage.

Unit Inspection

When the unit is delivered, verify that it is the correct unit and that it is properly equipped. Compare the information which appears on the unit nameplate with the

ordering and submittal information. Inspect all exterior components for visible damage. Report any apparent damage or material shortage to the carrier and make a "unit damage" notation on the carrier's delivery receipt. Specify the extent and type of damage found and notify the appropriate Trane Sales Office. Do not proceed with installation of a damaged unit without sales office approval.

Inspection Checklist

To protect against loss due to damage incurred in transit, complete the following checklist upon receipt of the unit.

- Inspect the individual pieces of the shipment before accepting the unit. Check for obvious damage to the unit or packing material.
- Inspect the unit for concealed damage as soon as possible after delivery and before it is stored. Concealed damage must be reported within 15 days.
- If concealed damage is discovered, stop unpacking the shipment. Do not remove damaged material from the receiving location. Take photos of the

damage, if possible. The owner must provide reasonable evidence that the damage did not occur after delivery.

- Notify the carrier's terminal of the damage immediately, by phone and by mail. Request an immediate, joint inspection of the damage with the carrier and the consignee.
- Notify the Trane sales representative and arrange for repair. Do not repair the unit, however, until damage is inspected by the carrier's representative.

Loose Parts Inventory

Check all the accessories and loose parts which are shipped with the unit against the shipping list. Included in these items will be water vessel drain plugs, rigging and electrical diagrams, and service literature, which are placed inside the control panel and/or starter panel for shipment.

Unit Description

The 140 - 500 ton Model RTAC units are helical-rotary type, air-cooled liquid chillers designed for installation outdoors. The compressor circuits are completely assembled, hermetic packages that are factory-piped, wired, leak-tested, dehydrated, and tested for proper control operation before shipment.

NOTE: Packaged units are factory charged with refrigerant and oil.

Precautions against product corrosion

It is recommended that air conditioning equipment shall not be installed in environments with a corrosive atmosphere such as acid or alkali gases and environments with a sea breeze.

In need of installing air conditioning equipment in these areas, Trane of Brazil recommends the application of extra protection against corrosion, such as Phenolic protection or the application of ADSIL.

For more information, contact your local distributor.

General Information

Fig. II - 01 - Typical RTAC Unit

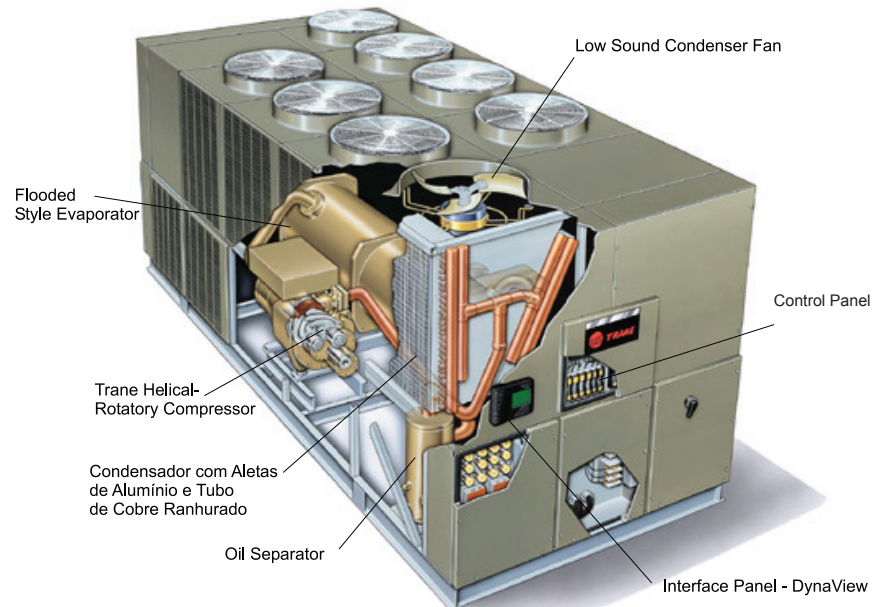

Chilled water inlet and outlet openings are covered for shipment. Each compressor has a separate compressor motor starter. The RTAC series features Trane's exclusive Adaptive Control™ logic, which monitors the control variables that govern the operation of the chiller unit. Adaptive Control logic can adjust capacity variables to avoid chiller shutdown when necessary, and keep producing chilled water. The units feature two independent refrigerant circuits. Compressor unloaders are solenoid actuated and oil pressure operated. Each refrigerant circuit is provided with filter, sight glass, electronic expansion valve,

and charging valves. The shell-and-tube type evaporator is manufactured in accordance with ASME standards or other international codes. Each evaporator is fully insulated and is equipped with water drain and vent connections. Packaged units have heat tape protection to - 20°F (-28.9°C) as standard. As an option, a convenience outlet can be supplied.

General Information

Fig. II-02 – The photographs below show the RTAC in two views.

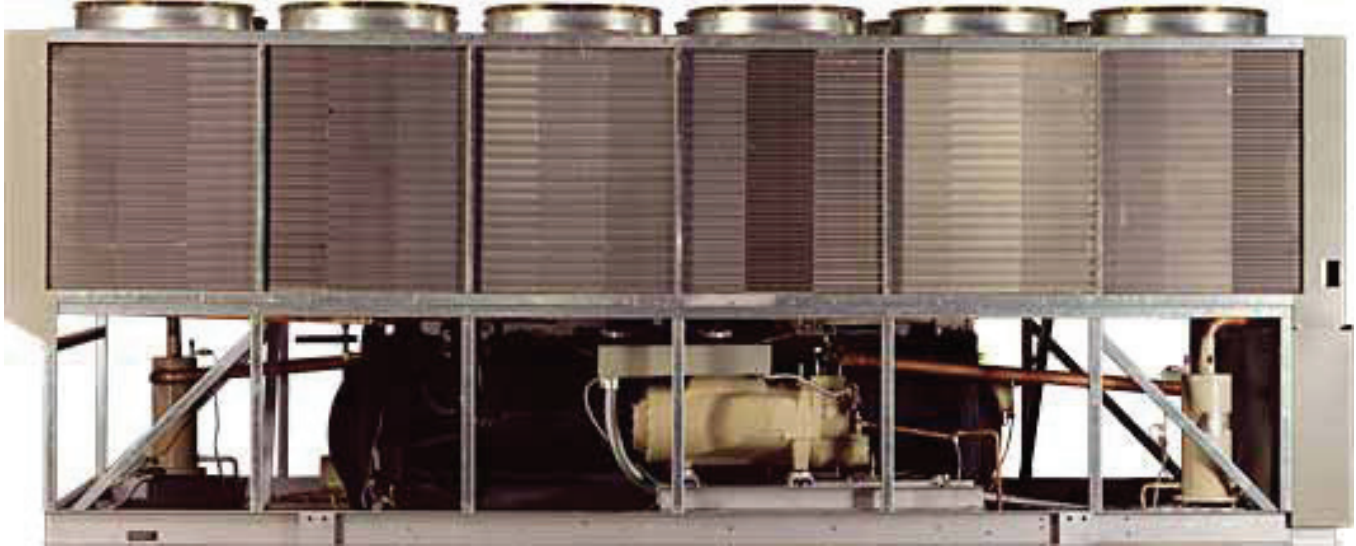



General Information

Tab. II-01 - General data — 140-350 ton 60 Hz units - standard efficiency

Size		140	155	170	185	200	225	250	275	300	350
Type		STD	STD	STD	STD	STD	STD	STD	STD	STD	STD
Compressor											
Quantity		2	2	2	2	2	2	2	3	3	3
Nominal Size	Tons	70/70	85/70	85/85	100/85	100/100	120/100	120/120	85-85/100	100-100/100	120-120/100
Evaporator											
Water storage	(gallons)	29	32	33	35	39	38	42	60	65	70
	(liters)	111	121	127	134	146	145	158	229	245	264
2 pass arrangement											
Minimum flow	(gpm)	193	214	202	217	241	217	241	309	339	375
	(l/s)	12	14	13	14	15	14	15	20	21	24
Maximum flow	(gpm)	709	785	741	796	883	796	883	1134	1243	1374
	(l/s)	45	50	47	50	56	50	56	72	78	87
3 Pass arrangement											
Minimum flow	(gpm)	129	143	135	145	161	145	161	206	226	250
	(l/s)	8	9	9	9	10	9	10	13	14	16
Maximum flow	(gpm)	473	523	494	531	589	531	589	756	829	916
	(l/s)	30	33	31	33	37	33	37	48	52	58
Condenser											
Qty of coils		4	4	4	4	4	4	4	8	8	8
Coil length	(inches)	156/156	180/156	180/180	216/180	216/216	252/216	252/252	180/108	216/108	252/108
	(mm)	3962/3962	4572/3962	4572/4572	5486/4572	5486/5486	6401/5486	6401/6401	4572/2743	5486/2743	6401/4572
Coil height	(inches)	42	42	42	42	42	42	42	42	42	42
	(mm)	1067	1067	1067	1067	1067	1067	1067	1067	1067	1067
Fins/Ft		192	192	192	192	192	192	192	192	192	192
Number of rows		3	3	3	3	3	3	3	3	3	3
Condenser fans											
Quantity		4/4	5/4	5/5	6/5	6/6	7/6	7/7	10/6	12/6	14/6
	(inches)	30	30	30	30	30	30	30	30	30	30
Diameter	(mm)	762	762	762	762	762	762	762	762	762	762
Total airflow	(cfm)	77000	84542	92087	101296	110506	119725	128946	147340	165766	184151
	(m ³ /h)	130811	143623	156441	172086	187732	203394	219059	250307	281610	312843
Nominal fan speed	(rpm)	1140	1140	1140	1140	1140	1140	1140	1140	1140	1140
	(rps)	19	19	19	19	19	19	19	19	19	19
	(ft/min)	8954	8954	8954	8954	8954	8954	8954	8954	8954	8954
Tip Speed	(m/s)	45	45	45	45	45	45	45	45	45	45
Motor Power	HP	1,0	1,0	1,0	1,0	1,0	1,0	1,0	1,0	1,0	1,0
Minimum staling/ operating ambient (2)	(kW)	0,75	0,75	0,75	0,75	0,75	0,75	0,75	0,75	0,75	0,75
Std Unit											
Low ambient	(°F)	25	25	25	25	25	25	25	25	25	25
	(°C)	-3,9	-3,9	-3,9	-3,9	-3,9	-3,9	-3,9	-3,9	-3,9	-3,9
General unit	(°F)	0	0	0	0	0,0	0	0	0	0	0
	(°C)	-17,8	-17,8	-17,8	-17,8	-17,8	-17,8	-17,8	-17,8	-17,8	-17,8
Refrigerant											
		HFC-134a	HFC-134a	HFC-134a	HFC-134a	HFC-134a	HFC-134a	HFC-134a	HFC-134a	HFC-134a	HFC-134a
N° of independent refrigerant circuits		2	2	2	2	2	2	2	2	2	2
% Minimum Load		15	15	15	15	15	15	15	15	15	15
	(pounds)	165/165	175/165	175/175	215/210	215/215	225/215	225/225	365/200	415/200	460/200
Refrigerant charge (1)	(kg)	75/75	79/75	79/79	98/95	98/98	102/98	102/102	166/91	188/91	209/91
	(gallons)	1.5/1.5	1.5/1.5	1.5/1.5	2.1/1.5	2.1/2.1	2.1/2.1	2.1/2.1	4.6/2.1	5.0/2.1	5.0/2.1
Oil charge (1)	(liters)	6/6	6/6	6/6	6/8	8/8	8/8	8/8	17/8	19/8	19/8

Notes:

1. Data containing information on two circuits shown as follows: CKT 1/CKT 2
2. Minimum start-up/operating ambient based on a 5 mph wind across the condenser



General Information

Tab. II-02 - General data — 140-400 ton 60 Hz units - high efficiency

Size		140	155	170	185	200	225	250	275	300
Type		HIGH	HIGH	HIGH	HIGH	HIGH	HIGH	HIGH	HIGH	HIGH
Compressor										
Quantity		2	2	2	2	2	2	2	3	3
Nominal Size	Tons	70/70	85/70	85/85	100/85	100/100	120/100	120/120	85-85/100	100-100/100
Evaporator										
	(gallons)	33	35	39	38	42	42	42	70	70
Water Storage	(liters)	127	134	146	145	158	158	158	264	264
2 Pass Arrangement										
	(gpm)	202	217	241	217	241	241	241	375	375
Min. Flow	(l/seg.)	13	14	15	14	15	15	15	24	24
	(gpm)	741	796	883	796	883	883	883	1374	1374
Max. Flow	(l/seg.)	47	50	56	50	56	56	56	87	87
3 Pass Arrangement										
	(gpm)	135	145	161	145	161	161	161	250	250
Min. Flow	(l/seg.)	9	9	10	9	10	10	10	16	16
	(gpm)	494	531	589	531	589	589	589	916	916
Max. Flow	(l/seg.)	31	33	37	33	37	37	37	58	58
Condenser										
Quantity of Coils		4	4	4	4	4	8	8	8	8
Coil Length	(inches)	180/180	216/180	216/216	252/216	252/252	144/144	144/144	216/144	252/144
	(mm)	4572/4572	5486/4572	5486/5486	6401/5486	6401/6401	3658/3658	4572/2743	5486/3658	6401/3658
Coil Height	(inches)	42	42	42	42	42	42	42	42	42
	(mm)	1067	1067	1067	1067	1067	1067	1067	1067	1067
Fins/ ft		192	192	192	192	192	192	192	192	192
Number of Rows		3	3	3	3	3	3	3	3	3
Condenser Fins										
Quantity		5/5	6/5	6/6	7/6	7/7	8/6	8/8	12/6	14/6
Diameter	(inches)	30	30	30	30	30	30	30	30	30
	(mm)	762	762	762	762	762	762	762	762	762
Total Airflow	(cfm)	91993	101190	110387	119598	128812	136958	147242	173733	192098
	(m³/h)	156281	171906	187530	203178	218831	232670	250141	295145	326344
Nominal Fan Speed	(rpm)	1140	1140	1140	1140	1140	1140	1140	1140	1140
	(rps)	19	19	19	19	19	19	19	19	19
Tip Speed	(ft/min)	8954	8954	8954	8954	8954	8954	8954	8954	8954
	(m/s)	45	45	45	45	45	45	45	45	45
Motor Nominal (Ea)	HP	1,0	1,0	1,0	1,0	1,0	1,0	1,0	1,0	1,0
Min Starting/ Oper Ambient	(kW)	0,75	0,75	0,75	0,75	0,75	0,75	0,75	0,75	0,75
Std Unit										
Low Ambient	(°F)	25	25	25	25	25	25	25	25	25
	(°C)	-3,9	-3,9	-3,9	-3,9	-3,9	-3,9	-3,9	-3,9	-3,9
General Ambient	(°F)	0	0	0	0	0	0	0	0	0
	(°C)	-17,8	-17,8	-17,8	-17,8	-17,8	-17,8	-17,8	-17,8	-17,8
Refrigerant										
		HFC-134a	HFC-134a	HFC-134a	HFC-134a	HFC-134a	HFC-134a	HFC-134a	HFC-134a	HFC-134a
N° of independent refrigerant circuits		2	2	2	2	2	2	2	2	2
% Min. Load		15	15	15	15	15	15	15	15	15
	(lb)	175/175	215/205	215/215	225/215	225/225	235/235	235/235	415/200	460/200
Refrigerant Charge	(kg)	79/79	98/93	98/98	102/98	102/102	107/107	107/107	188/91	209/91
	(gallones)	1.5/1.5	1.5/1.5	1.5/1.5	2.1/1.5	2.1/2.1	2.1/2.1	2.1/2.1	4.6/2.2	5.0/2.2
Oil Charge	(liters)	6/6	6/6	6/6	6/8	8/8	8/8	8/8	17/8	19/8

Notes:

1. Data containing information on two circuits shown as follows: CKT 1/CKT 2
2. Minimum start-up/operating ambient based on a 5 mph wind across the condenser



General Information

Tab. II-03 - General data — 140-400 ton 50 Hz units - standard efficiency

Size		140	155	170	185	200	250	275	300	350
Type		STD	STD	STD	STD	STD	STD	STD	STD	STD
Compressor										
Quantity		2	2	2	2	2	3	3	3	4
Nominal Size	Tons	70/70	85/70	85/85	100/85	100/100	70-70/100	85-85/100	100-100/100	85-85/85-85
Evaporator										
Water Storage	(gallons)	29	32	33	35	39	54	60	66	71
	(liters)	111	121	127	134	146	205	227	249	265
2 Pass arrangement										
Min. Flow	(gpm)	193	214	202	217	241	265	309	339	351
	(l/seg.)	12	14	13	14	16	15	17	20	29
Max. Flow	(gpm)	709	785	741	796	883	883	1134	1243	1374
	(l/seg.)	45	50	47	50	56	56	72	78	87
3 Pass arrangement										
Min. Flow	(gpm)	129	143	135	145	161	176	206	226	234
	(l/seg.)	8	9	9	9	10	11	13	14	15
Max. Flow	(gpm)	473	523	494	531	589	647	756	829	858
	(l/seg.)	30	33	31	33	37	41	48	52	54
Condenser										
Quantity of Coils		4	4	4	4	4	8	8	8	8
Coil Length	(inches)	156/156	180/156	180/180	216/180	216/216	156/108	180/108	216/108	180/180
	(mm)	3962/3962	4572/3962	4572/4572	5486/4572	5486/5486	3962/4572	4572/2743	5486/2743	4572/4572
Coil Height	(inches)	42	42	42	42	42	42	42	42	42
	(mm)	1067	1067	1067	1067	1067	1067	1067	1067	1067
Fins/ Ft		192	192	192	192	192	192	192	192	192
Number of Rows		3	3	3	3	3	3	3	3	3
Condenser Fans										
Quantity		4/4	5/4	5/5	6/5	6/6	8/6	10/6	12/6	10/10
Diameter	(inches)	30	30	30	30	30	30	30	30	30
	(mm)	762	762	762	762	762	762	762	762	762
Total AirFlow	(cfm)	63346	69507	75671	83236	90803	108698	121056	136210	151332
	(m³/h)	107615	118081	128553	141405	141405	184661	205655	231399	257089
Nominal Fan Speed	(rpm)	950	950	950	950	950	950	950	950	950
	(rps)	15,8	15,8	15,8	15,8	15,8	15,8	15,8	15,8	15,8
Tip Speed	(ft/min)	7461	7461	7461	7461	7461	7461	7461	7461	7461
	(m/s)	38	38	38	38	38	38	38	38	38
Motor nominal (Ea)	HP	1,5	1,5	1,5	1,5	1,5	1,5	1,5	1,5	1,5
Min. Starting/ Oper Ambient	(kW)	1,1	1,1	1,1	1,1	1,1	1,1	1,1	1,1	1,1
Std. Unit										
Low ambient	(°F)	25	25	25	25	25	25	25	25	25
	(°C)	-3,9	-3,9	-3,9	-3,9	-3,9	-3,9	-3,9	-3,9	-3,9
General Unit	(°F)	0	0	0	0	0	0	0	0	0
	(°C)	-17,8	-17,8	-17,8	-17,8	-17,8	-17,8	-17,8	-17,8	-17,8
Refrigerant										
		HFC-134a	HFC-134a	HFC-134a	HFC-134a	HFC-134a	HFC-134a	HFC-134a	HFC-134a	HFC-134a
N° of independent refrigerant circuits		2	2	2	2	2	2	2	2	2
% min. load		15	15	15	15	15	15	15	15	15
	(lb)	165/165	175/165	175/175	215/210	215/215	335/200	365/200	415/200	365/365
Refrigerant charge	(kg)	75/75	79/75	79/79	98/95	98/98	152/91	166/91	188/91	166/166
	(gallons)	1.5/1.5	1.5/1.5	1.5/1.5	2.1/1.5	2.1/2.1	4.6/2.1	4.6/2.1	5.0/2.1	4.6/4.6
Oil charge	(liters)	6/6	6/6	6/6	6/8	8/8	17/8	17/8	19/8	17/17

Notes:

1. Data containing information on two circuits shown as follows: CKT 1/CKT 2
2. Minimum start-up/operating ambient based on a 5 mph wind across the condenser



General Information

Tab. II-04 - General data — 140-400 ton 50 Hz units - high efficiency

Size		140	155	170	185	200	250	275	300
Type		HIGH	HIGH	HIGH	HIGH	HIGH	HIGH	HIGH	HIGH
Compressor									
Quantity		2	2	2	2	2	3	3	3
Nominal Size	Tons	70/70	85/70	85/85	100/85	100/100	70-70/100	85-85/100	100-100/100
Evaporator									
Water Storage	(gallons)	33	35	39	38	42	66	71	71
	(liters)	127	134	146	145	158	249	267	267
2 Pass arrangement									
	(gpm)	202	217	241	217	241	241	241	375
Min. Flow	(l/seg.)	13	14	15	14	15	15	15	24
Max. Flow	(gpm)	741	796	883	796	883	883	883	1374
	(l/seg.)	47	50	56	50	56	56	56	87
3 Pass arrangement									
	(gpm)	135	145	161	145	161	226	250	250
Min. Flow	(l/seg.)	9	9	10	9	10	14	16	16
	(gpm)	494	531	589	531	589	829	916	916
Max. Flow	(l/seg.)	31	33	37	33	37	52	58	58
Condenser									
Qty of Coils		4	4	4	4	4	8	8	8
Coil Legth	(inches)	180/180	216/180	216/216	252/216	252/252	180/108	216/144	252/144
	(mm)	4572/4572	5486/4572	5486/5486	6401/5486	6401/6401	4572/2743	5486/3658	6401/3658
Coil Height	(inches)	42	42	42	42	42	42	42	42
	(mm)	1067	1067	1067	1067	1067	1067	1067	1067
Fins/ Ft		192	192	192	192	192	192	192	192
Number of Rows		3	3	3	3	3	3	3	3
Condenser Fans									
Quantity		5/5	6/5	6/6	7/6	7/7	10/6	12/6	14/6
Diameter	(inches)	30	30	30	30	30	30	30	30
	(mm)	762	762	762	762	762	762	762	762
Total Airflow	(cfm)	75575	83130	90687	98256	105826	120971	142969	158112
	(m³/h)	128390	141225	154063	166921	179781	205510	242881	268607
Nominal Fan Speed	(rpm)	950	950	950	950	950	950	950	950
	(rps)	15,8	15,8	15,8	15,8	15,8	15,8	15,8	15,8
	(ft/min)	7461	7461	7461	7461	7461	7461	7461	7461
Tip Speed	(m/s)	38	38	38	38	38	38	38	38
Motor Nominal (Ea)	HP	1.5	1.5	1.5	1.5	1.5	1.5	1.5	1.5
Min Starting/ Oper Ambient	(kW)	1.1	1.1	1.1	1.1	1.1	1.1	1.1	1.1
Std. Unit									
Low Ambient	(°F)	25	25	25	25	25	25	25	25
	(°C)	-3,9	-3,9	-3,9	-3,9	-3,9	-3,9	-3,9	-3,9
General Unit	(°F)	0	0	0	0	0	0	0	0
	(°C)	-17,8	-17,8	-17,8	-17,8	-17,8	-17,8	-17,8	-17,8
Refrigerant									
		HFC-134a	HFC-134a	HFC-134a	HFC-134a	HFC-134a	HFC-134a	HFC-134a	HFC-134a
N° of independent refrigerant circuits		2	2	2	2	2	2	2	2
% Min. Load		15	15	15	15	15	15	15	15
Refrigerant Charge	(lb)	175/175	215/205	215/215	225/215	225/225	335/195	385/15	430/215
	(kg)	79/79	98/93	98/98	102/98	102/102	152/88	175/97	195/97
Oil Charge	(galones)	1.5/1.5	1.5/1.5	1.5/1.5	2.1/1.5	2.1/2.1	4.6/2.1	4.6/2.1	5.0/2.1
	(l)	6/6	6/6	6/6	8/6	8/8	17/8	17/8	19/8

Notes:

1. Data containing information on two circuits shown as follows: CKT 1/CKT 2
2. Minimum start-up/operating ambient based on a 5 mph wind across the condenser

General Information

Identification Tag

The RTAC identification tags are fixed on external control panel surface.

The compressors tags are fixed on compressor.

An example of tag is shown below.

Fig. II-03 – Etiquetas de identificación

TAG		TAG1
 TRANE TRANE DO BRASIL IND.COM.PROD.COMD.DE AR LTDA Av. dos Pinheiros,565 – Araucária – PR – Brasil		
MODELO / MODEL / MODELO		
RTAC350JBAONNOFNATY2NDCNNONN10NNOPON0000N		
ITEM	RTAC350000002	
NÚMERO DE SÉRIE	B1109C0017	
SERIAL NUMBER		
NUMERO DE SERIE		
DATA DE FABRICAÇÃO / MANUFACTURING DATE / FECHA DE FABRICACION		
		11/2009
ALIMENTAÇÃO ELÉTRICA / ELECTRICAL RATING / SUMINISTRO ELECTRICO		
		380V / 60Hz
POTÊNCIA NOMINAL / POWER CONSUMPTION / CONSUMO DE ENERGIA		
		410 kW
AMPACIDADE MÍNIMA / MINIMUM AMPACITY (MCA) / AMPACIDAD MINIMA		
		594/275 A
CORRENTE DE PARTIDA / LOCKED ROTOR AMPS / CORRIENTE DE ARRANQUE		
		923 A
MÁX. FUSÍVEL/DISJUNTOR / MAX. FUSE / BREAKER / MAX. FUSIBLE / DISYUNTOR		
		800/450 A
TIPO DE REFRIGERANTE / REFRIGERANT TYPE / TIPO DE REFRIGERANTE		
		R134a
TIPO DE ÓLEO / OIL TYPE / TIPO DE ACEITE		
		TRANE OIL00048
CIRCUITO 1 / CIRCUIT 1		
COMPRESSOR	COMPRESSOR / COMPRESOR	D2 X CHHP0N2
CARGA REFRIGERANTE	REFRIGERANT CHARGE / CARGA REFRIGERANTE	209 kg
CARGA DE ÓLEO	OIL CHARGE / CARGA DE ACEITE	19.0 L
MOTOR VENTILADOR	FAN MOTOR / MOTOR VENTILADOR	14 x 1.0HP
CIRCUITO 2 / CIRCUIT 2		
COMPRESSOR	COMPRESSOR / COMPRESOR	CHHP0N1
CARGA REFRIGERANTE	REFRIGERANT CHARGE / CARGA REFRIGERANTE	91 kg
CARGA DE ÓLEO	OIL CHARGE / CARGA DE ACEITE	8.0 L
MOTOR VENTILADOR	FAN MOTOR / MOTOR VENTILADOR	6 x 1.0HP
PRESSÃO DE TESTE (BAIXA/ALTA) / TEST PRESSURE (LOW/HIGH) / PRESION DE PRUEBA (BAJO/ALTO)		
		250/440 PSI
PESO / WEIGHT / PESO		
		9738 Kg
Indústria Brasileira / Made in Brazil / Hecho en Brasil		

General Information

Fig. II-04 - Unit Dimensions 140 SE 155 SE - 50/60 HZ

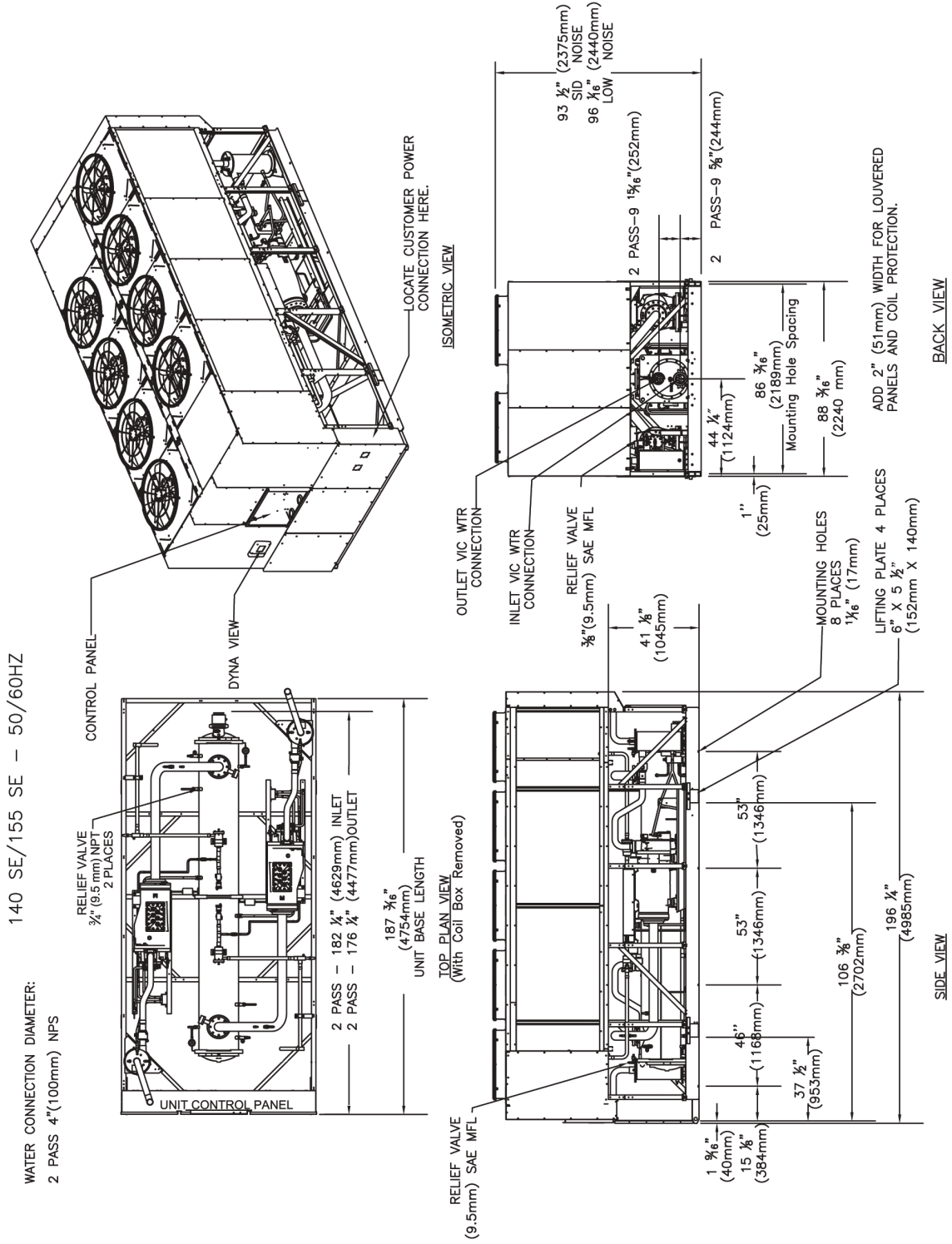

General Information

Fig. II-05 - Unit Dimensions 140 HE 170 SE - 50/60 HZ

140 HE/170SE - 50 / 60HZ

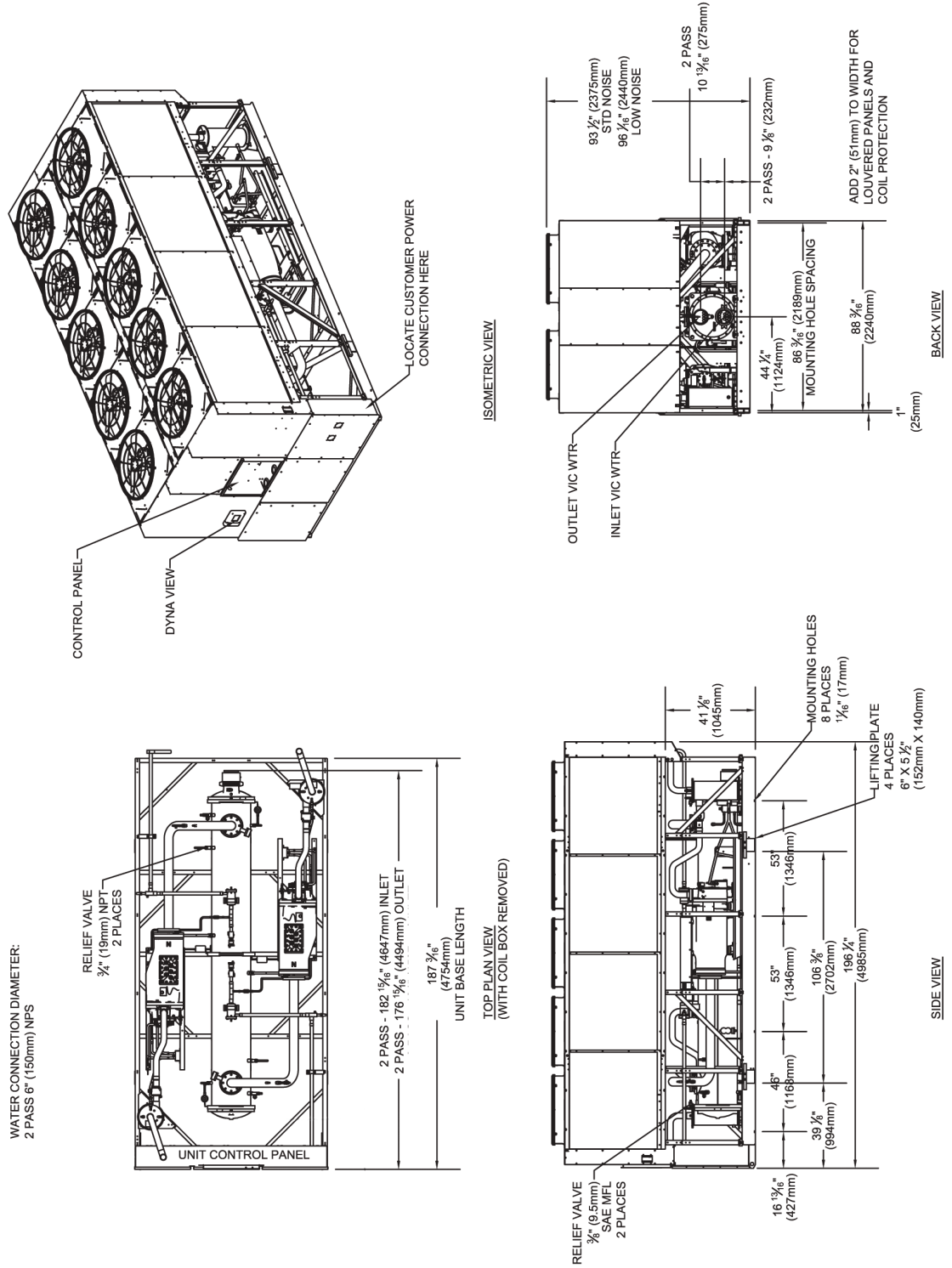

General Information

Fig. II-06 - Unit Dimensions 140 XE Ton, 60 Hz and 155-170 HE 185-200 Ton, High Efficiency, 50 and 60 Hz

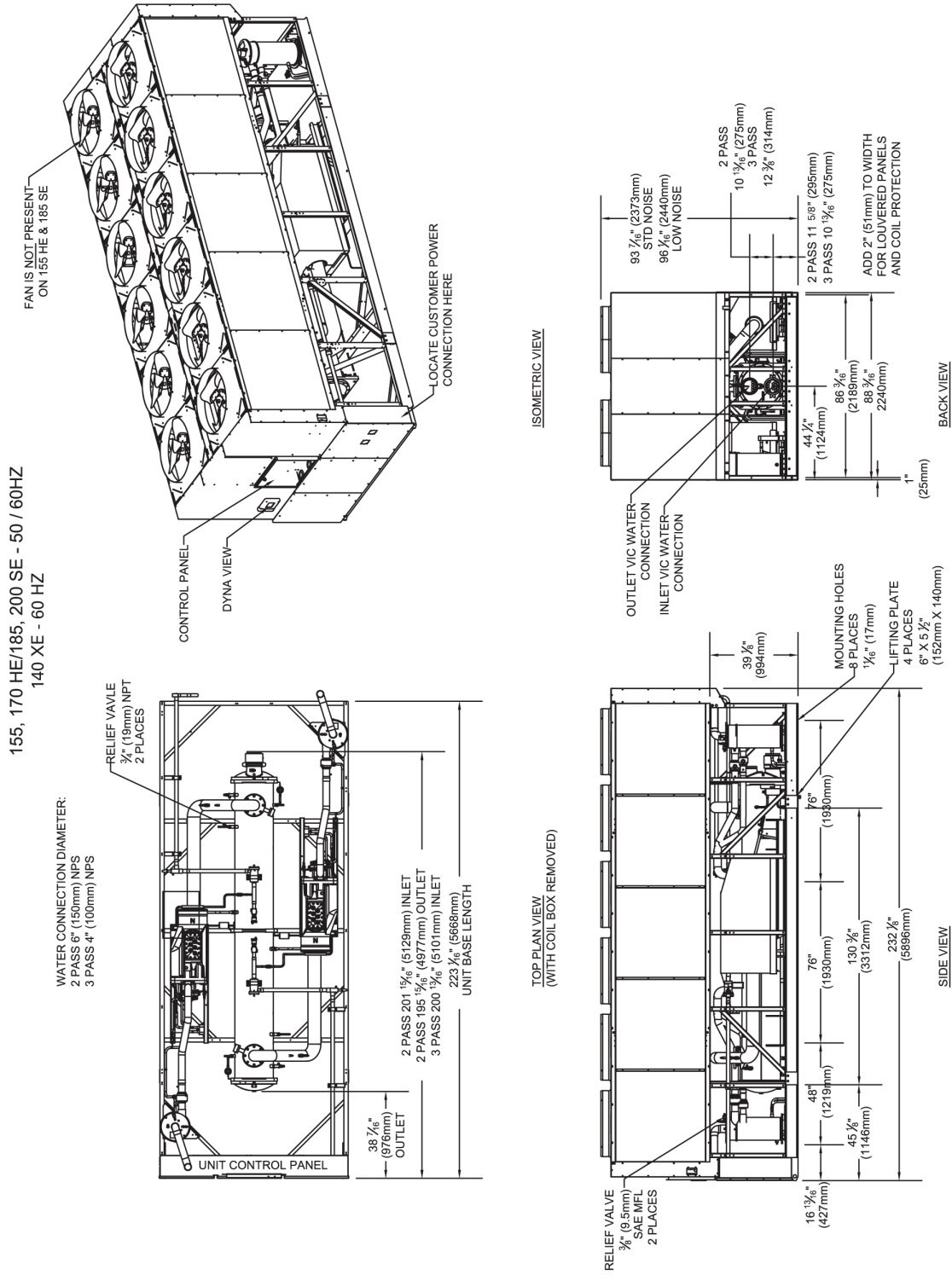

General Information

Fig. II-07 - Unit Dimensions 155-170 XE Ton, 60 Hz and 185-200 HE 225-250 SE Ton, 50 and 60 Hz.

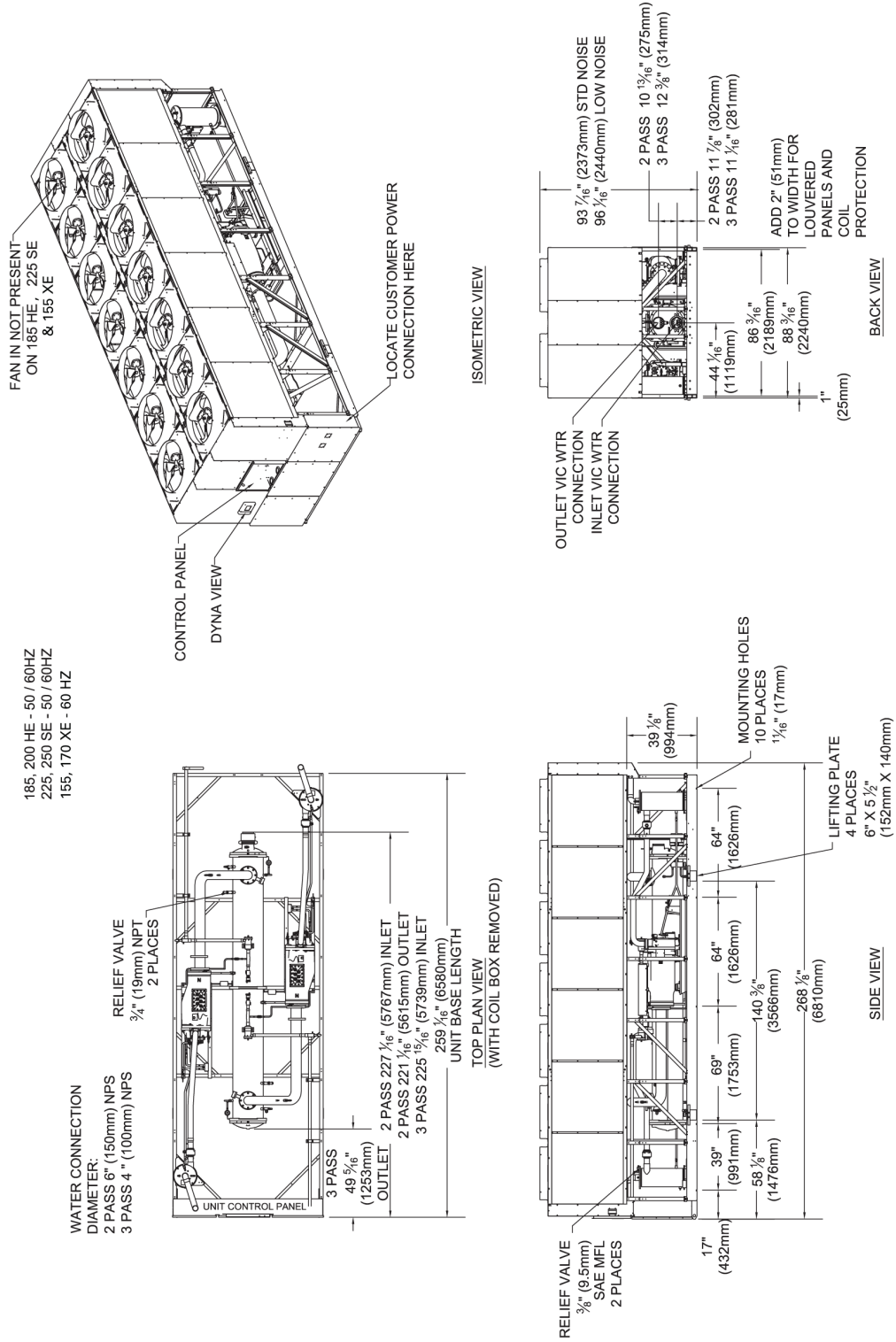

General Information

Fig. II-08 - Unit Dimensions 225-250 HE 185-200 XE Ton, 60 Hz

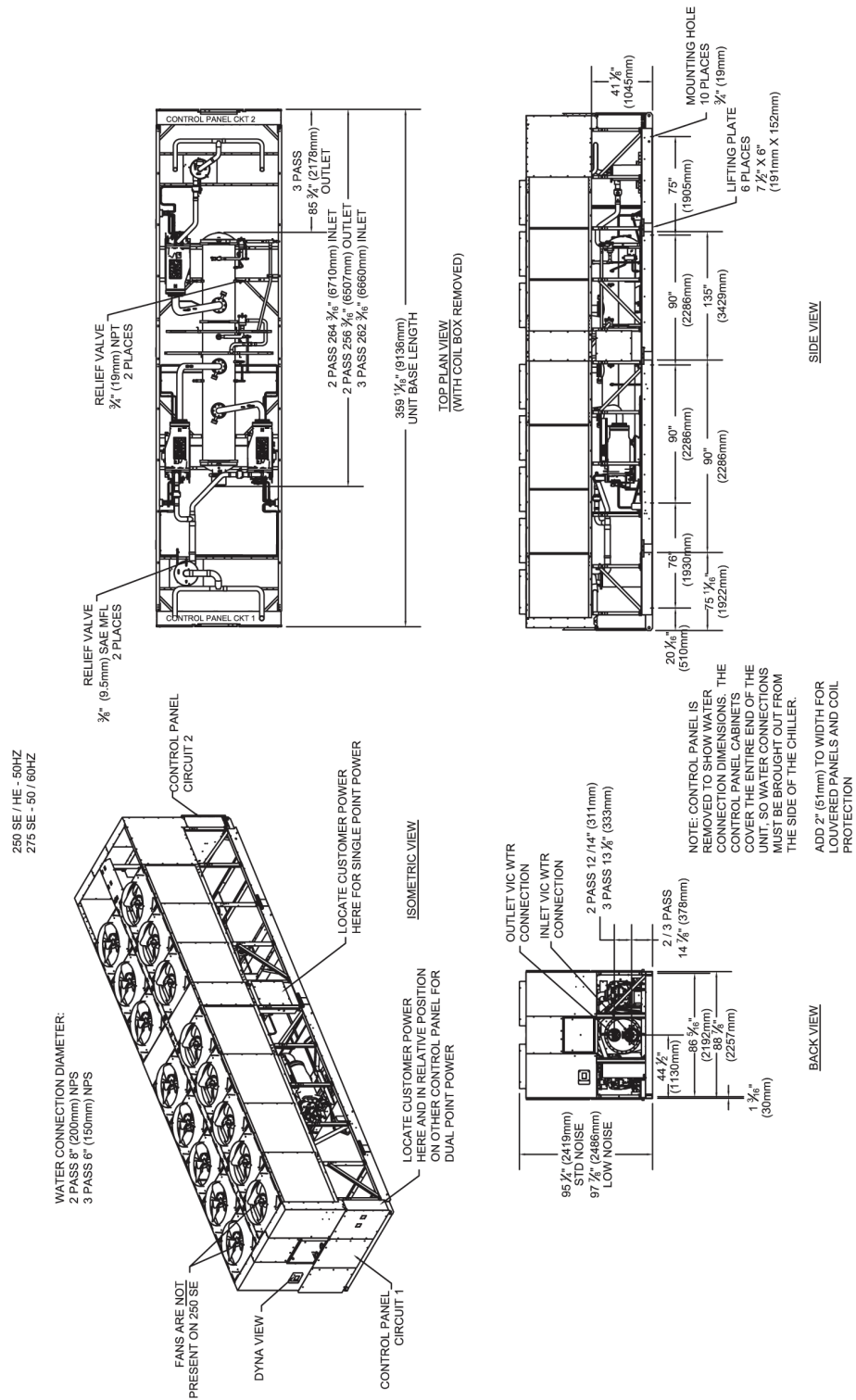

General Information

Fig. II-09 - Unit Dimensions 225-250 HE 185-200 XE Ton, 60 Hz

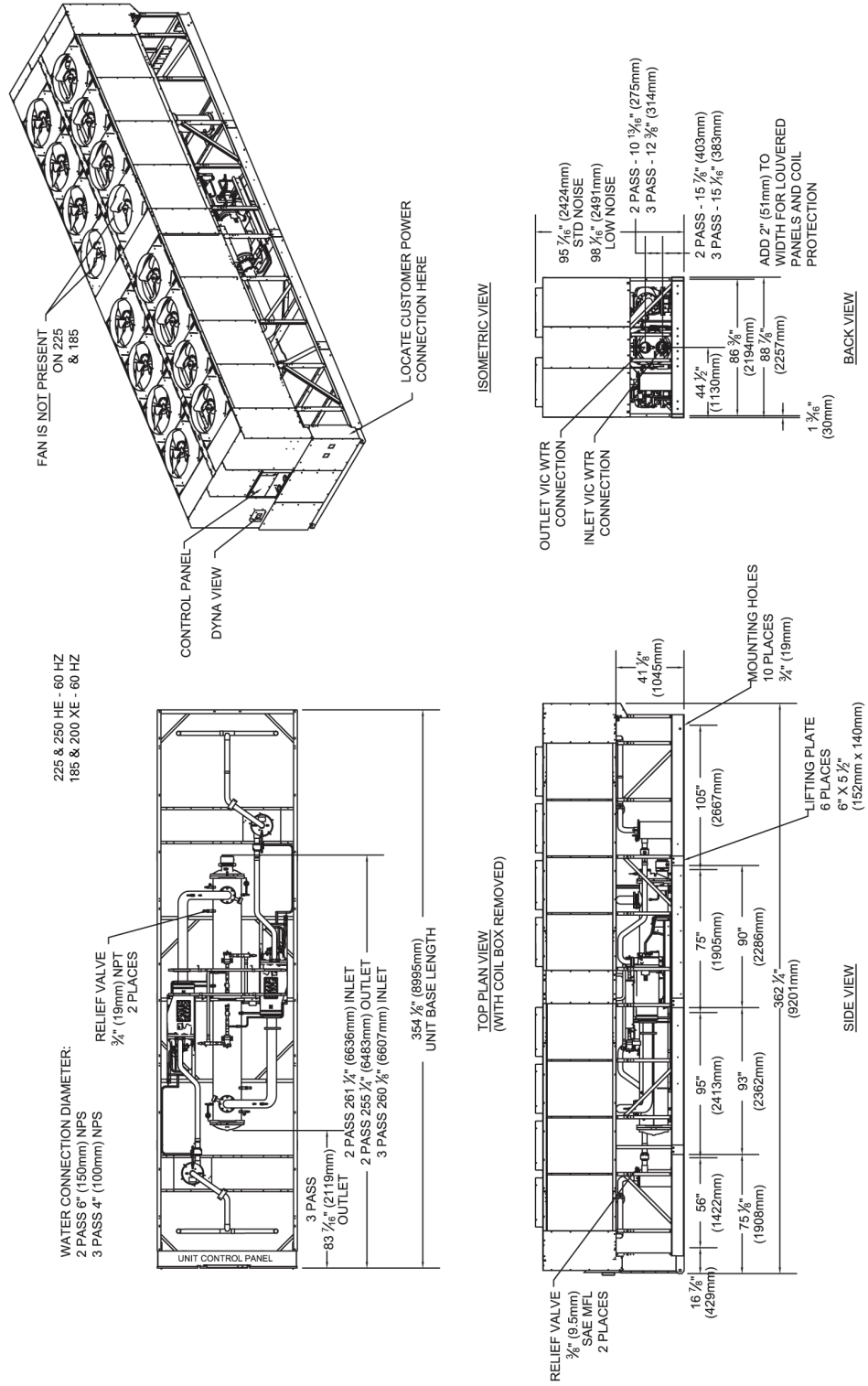

General Information

Fig. II-10 - Unit Dimensions 250 XE 350 SE Ton 60 Hz; 300 SE 275 HE Ton, 50 60 Hz

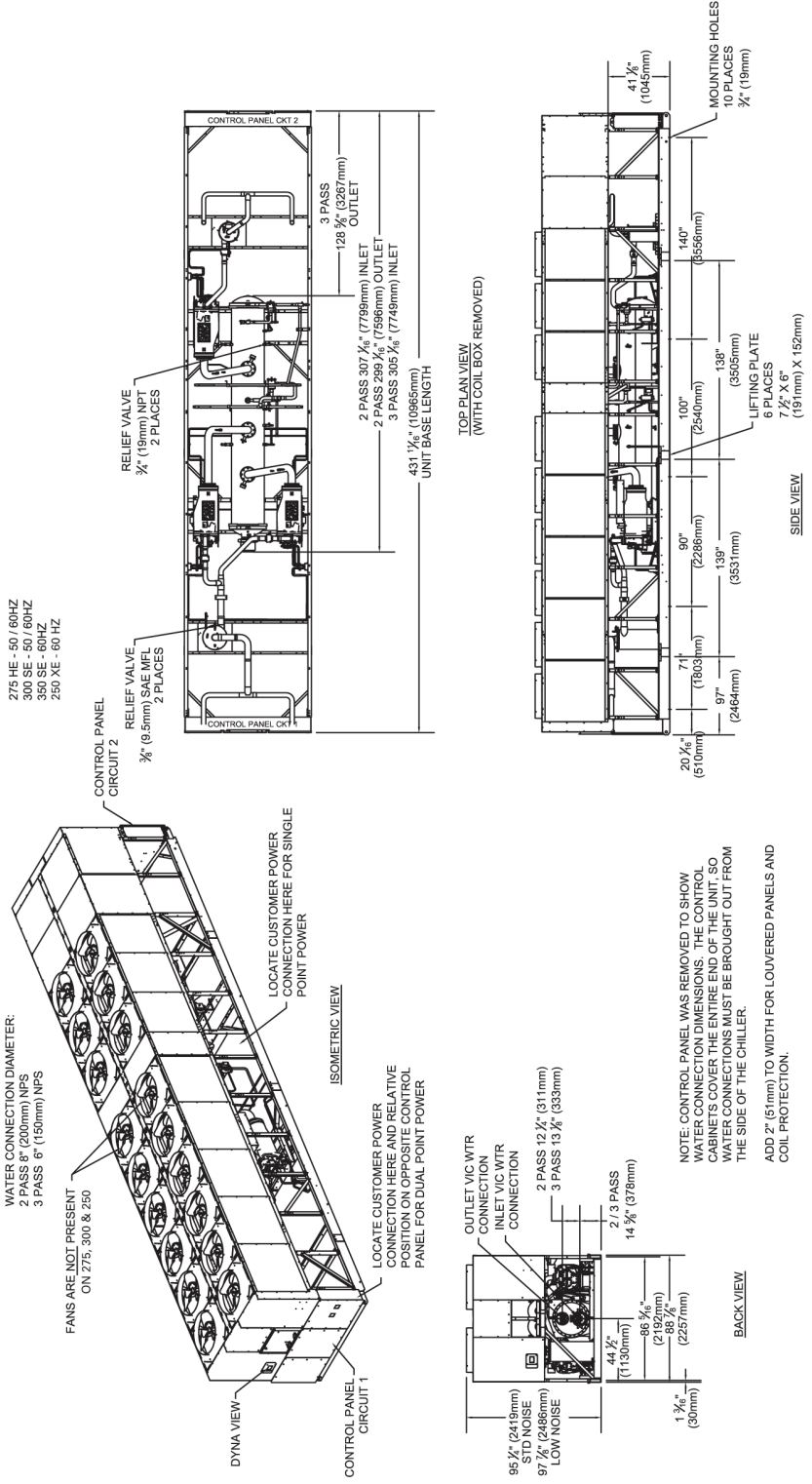

III-Installation Mechanical

Installation Responsibilities

Generally, the contractor must do the following when installing an RTAC unit:

- Install unit on a flat foundation, level (within 1/4" [6 mm] across the length and width of the unit), and strong enough to support unit loading.
- Install unit per the instructions contained in the Installation Mechanical and Installation Electrical sections of this manual.
- Install any optional sensors and make electrical connections at the CH530.
- Where specified, provide and install valves in water piping upstream and downstream of evaporator water connections to isolate the evaporator for maintenance, and to balance/trim system.
- Furnish and install flow switch to prove chilled water flow.
- Furnish and install pressure gauges in inlet and outlet piping of the evaporator.
- Furnish and install a drain valve to the bottom of the evaporator waterbox.
- Supply and install a vent cock to the top of the evaporator waterbox.
- Furnish and install strainers ahead of all pumps and automatic modulating valves, and at inlet of evaporator.
- Provide and install field wiring.
- Install heat tape and insulate the chilled water lines and any other portions of the system, as required, to prevent sweating under normal operating conditions or freezing during low ambient temperature conditions.
- Install evaporator drain plug. The plug ships in unit control panel.
- Start unit under supervision of a qualified service technician.

Nameplates

The RTAC outdoor unit nameplates (Figure 1) are applied to the exterior of the Control Panel. A compressor nameplate is located on each compressor.

Outdoor Unit Nameplate

The outdoor unit nameplate provides the following information:

- Unit model and size description.
- Unit serial number.
- Identifies unit electrical requirements.
- Lists correct operating charges of R-134a and refrigerant oil (Trane

OIL00048).

- Lists unit test pressures.
- Identifies installation, operation and maintenance and service data literature (Pueblo).
- Lists drawing numbers for unit wiring diagrams (Pueblo).

Compressor Nameplate

The compressor nameplate provides following information:

- Compressor model number.
- Compressor serial number.
- Compressor electrical characteristics.
- Utilization range.
- Recommended refrigerant.

Installation Mechanical

Storage

Extended storage of the outdoor unit prior to installation requires the following precautionary measures:

1. Store the outdoor unit in a secure area.
2. At least every three months (quarterly), check the pressure in the refrigerant circuits to verify that the refrigerant charge is intact. If it is not, contact a qualified service organization and the appropriate Trane sales office.
3. Close the discharge and liquid line isolation valves.

General

Report any damage incurred during handling or installation to the Trane sales office immediately.

Location Requirements

Setting the Unit

A base or foundation is not required if the selected unit location is level and strong enough to support the unit's operating weight as listed in Tables in the General Information section.

See Table for lifting weights and center of gravity (CG) dimensions.

Fig. III-01 – Lifting the Unit (Package and Remote) 15-21-foot Base

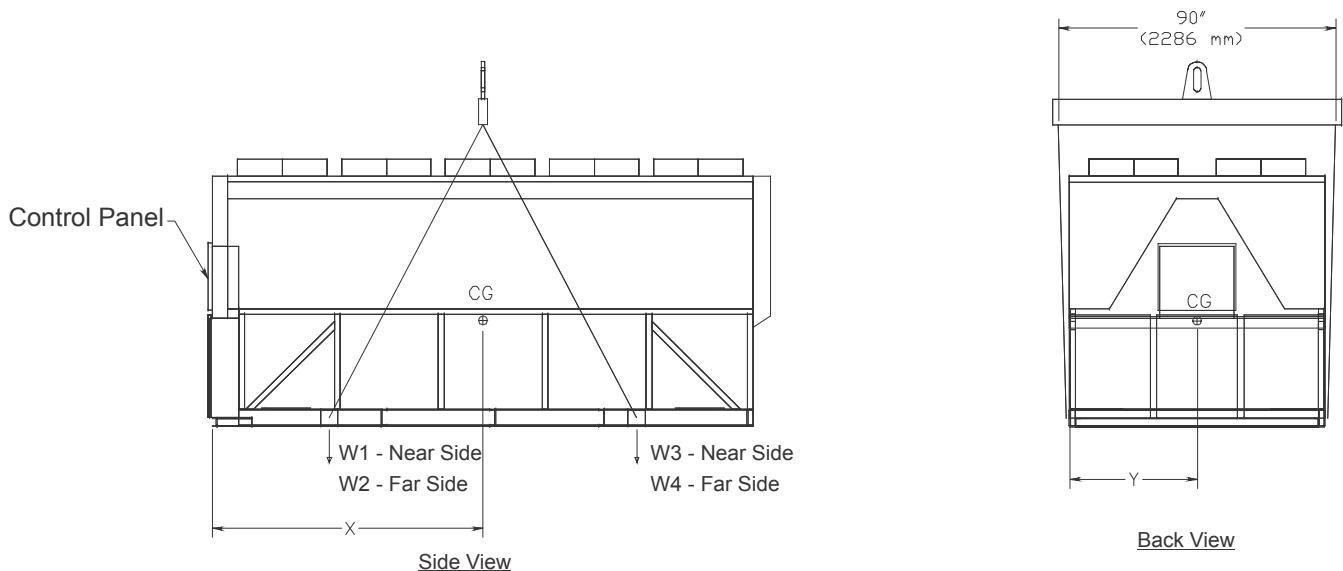

1. Lifting chains/cables will not be the same length. Adjust to keep unit level while lifting.
2. Do not fork lift unit.
3. Weights are typical for units with R-134a charge.

Installation Mechanical

Fig. III-02 – Lifting the Unit (Package and Remote) 30-36-foot Base

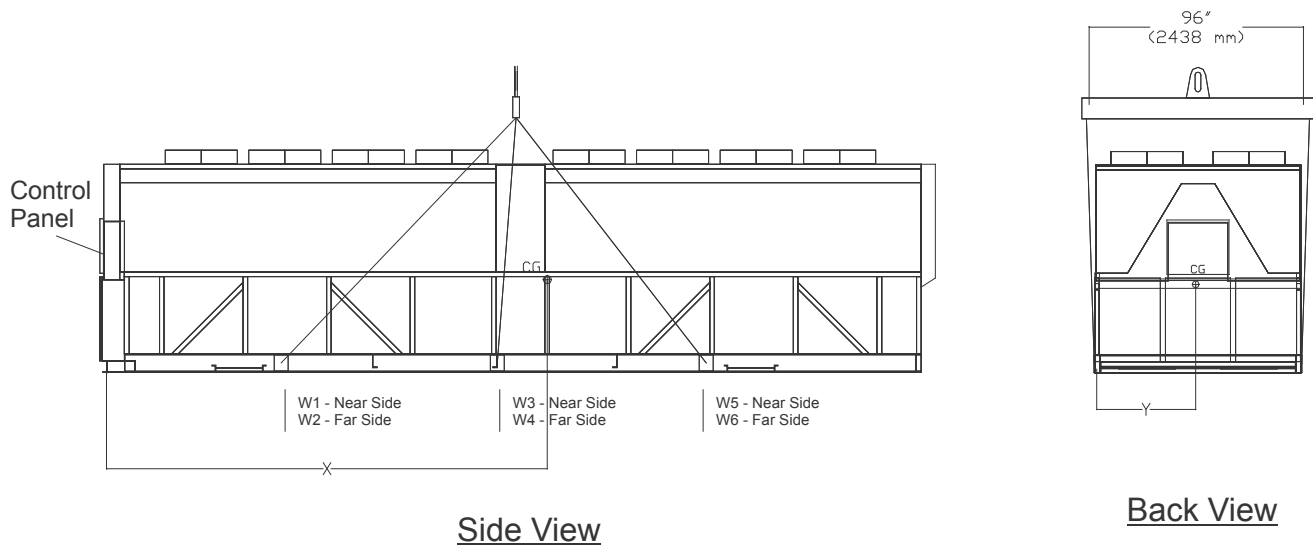

1. Lifting chains/cables will not be the same length. Adjust to keep unit level while lifting.
2. Do not fork lift unit.
3. Weights are typical for units with R-134a charge.

Fig. III-03 – Lifting the Unit 39-45-foot Base

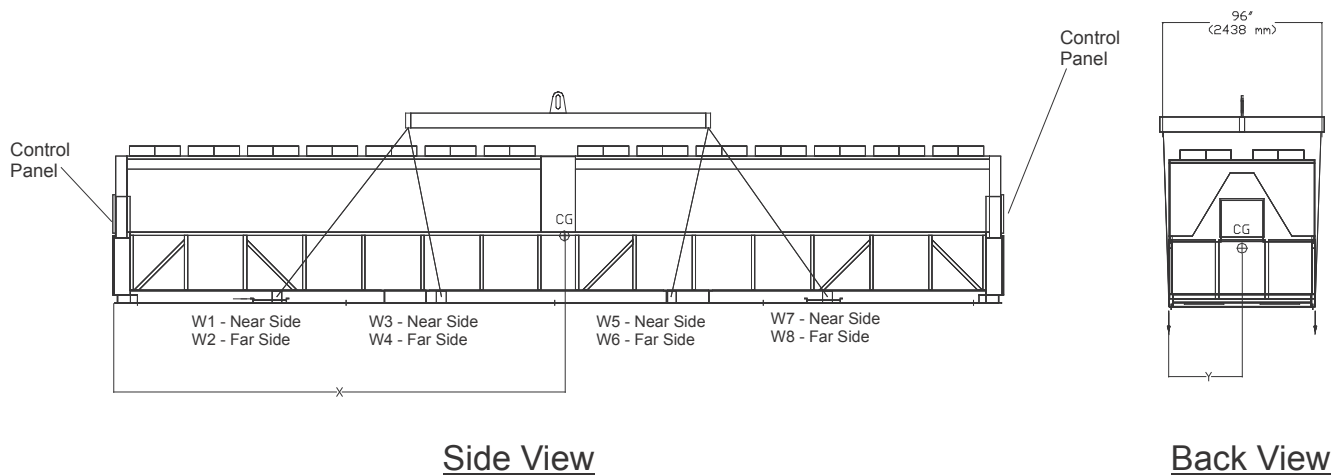

1. Lifting chains/cables will not be the same length. Adjust to keep unit level while lifting.
2. Do not fork lift unit.
3. Weights are typical for units with R-134a charge.



Installation Mechanical

Tab. III - 01 – Aluminum fin unit weights (60 Hz units)

Unit Size	W1	W2	W3	W4	W5	W6	W7	W8	Operating Weight	Shipping Weight	Xcg	Ycg
	lb	lb	lb	lb	lb	lb	lb	lb	lb	lb	in	in
	kg	kg	kg	kg	kg	kg	kg	kg	kg	kg	mm	mm
RTAC 140 STD	2423	2794	2602	2933	NA	NA	NA	NA	10995	10752	88	45
	1099	1267	1180	1330					4987	4877	2235	1143
RTAC 140 HIGH	2426	2800	2610	2943	NA	NA	NA	NA	11057	10780	88	45
	1100	1270	1184	1335					5015	4885	2235	1143
RTAC 155 STD	2427	2796	2608	2937	NA	NA	NA	NA	11034	10769	88	45
	1101	1268	1183	1332					5005	5460	2235	1143
RTAC 155 HIGH	3095	3489	2530	2924	NA	NA	NA	NA	12332	12038	106	45
	1404	1583	1148	1327					5594	4897	2692	1143
RTAC 170 STD	2429	2803	2615	2948	NA	NA	NA	NA	11073	10796	88	45
	1102	1272	1186	1337					5023	5488	2235	1143
RTAC 170 HIGH	3106	3506	2543	2944	NA	NA	NA	NA	12418	12098	106	46
	1409	1590	1153	1335					5633	5621	2692	1168
RTAC 185 STD	3222	3562	2634	2973	NA	NA	NA	NA	12685	12391	106	44
	1462	1616	1195	1349					5754	6304	2692	1118
RTAC 185 HIGH	4037	4117	2990	3581	NA	NA	NA	NA	14214	13897	124	45
	1831	1867	1356	1624					6447	5799	3150	1143
RTAC 200 STD	3260	3756	2796	3212	NA	NA	NA	NA	13104	12784	106	45
	1479	1704	1268	1457					5944	6462	2692	1143
RTAC 200 HIGH	3632	4187	3110	3578	NA	NA	NA	NA	14593	14247	124	45
	1648	1899	1411	1623					6619	6518	3150	1143
RTAC 225 STD	3632	4229	3114	3632	NA	NA	NA	NA	14687	14370	124	45
	1647	1918	1413	1647					6662	7184	3150	1143
RTAC 225 HIGH	2569	2892	2477	2800	2388	2711	NA	NA	16184	15838	166	44
	1165	1312	1124	1270	1083	1230			7341	6580	4216	1118
RTAC 250 STD	3691	4165	3088	3562	NA	NA	NA	NA	14853	14507	124	45
	1674	1889	1401	1616					6737	7243	3150	1143
RTAC 250 HIGH	2601	2897	2512	2808	2427	2723	NA	NA	16314	15968	166	44
	1180	1314	1140	1274	1101	1235			7400	8562	4216	1118
RTAC 275 STD	3345	2936	3351	2942	3356	2947	NA	NA	19536	18876	176	42
	1517	1332	1520	1334	1522	1337			8862	9193	4470	1067
RTAC 275 HIGH	3251	2863	3571	3183	3894	3505	NA	NA	20944	20266	203	42
	1475	1299	1620	1444	1766	1590			9500	9319	5156	1067
RTAC 300 STD	3456	3074	3615	3233	3774	3393	NA	NA	21103	20544	222	42
	1568	1394	1640	1466	1712	1539			9572	10210	5639	1067
RTAC 300 HIGH	2955	2628	2892	2565	2782	2495	2759	2432	22060	22508	222	42
	1340	1192	1312	1163	1262	1132	1251	1103	10006	9730	5639	1067
RTAC 350 STD	3374	2998	3772	3367	4172	3767	NA	NA	21904	21450	205	42
	1530	1360	1711	1527	1892	1709			9936	10797	5207	1067

Notes:

1. Operating weight includes refrigerant and water.
2. Shipping weight includes refrigerant.
3. All weights +/- 3%.

Unit Top (Plan) View

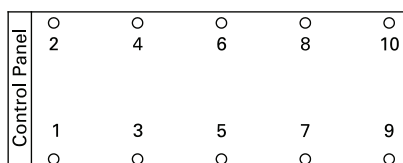

Unit Top (Plan) View

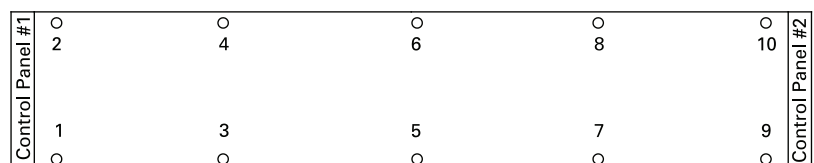



Installation Mechanical

Tab. III - 02 – Aluminum fin unit weights (50 Hz units)

Unit Size	W1	W2	W3	W4	W5	W6	W7	W8	Operating Weight	Shipping Weight	Xcg	Ycg
	lb	lb	lb	lb	lb	lb	lb	lb	lb	lb	in	in
	kg	kg	kg	kg	kg	kg	kg	kg	kg	kg	mm	mm
RTAC 140 STD	2423	2794	2602	2933	NA	NA	NA	NA	10995	10752	88	45
	1099	1267	1180	1330					4987	4877	2235	1143
RTAC 140 HIGH	2426	2800	2610	2943	NA	NA	NA	NA	11057	10780	88	45
	1100	1270	1184	1335					5015	4885	2235	1143
RTAC 155 STD	2427	2796	2608	2937	NA	NA	NA	NA	11034	10769	88	45
	1101	1268	1183	1332					5005	5460	2235	1143
RTAC 155 HIGH	3095	3489	2530	2924	NA	NA	NA	NA	12332	12038	106	45
	1404	1583	1148	1327					5594	4897	2692	1143
RTAC 170 STD	2429	2803	2615	2948	NA	NA	NA	NA	11073	10796	88	45
	1102	1272	1186	1337					5023	5488	2235	1143
RTAC 170 HIGH	3106	3506	2543	2944	NA	NA	NA	NA	12418	12098	106	46
	1409	1590	1153	1335					5633	5621	2692	1168
RTAC 185 STD	3222	3562	2634	2973	NA	NA	NA	NA	12685	12391	106	44
	1462	1616	1195	1349					5754	6304	2692	1118
RTAC 185 HIGH	4037	4117	2990	3581	NA	NA	NA	NA	14214	13897	124	45
	1831	1867	1356	1624					6447	5799	3150	1143
RTAC 200 STD	3260	3756	2796	3212	NA	NA	NA	NA	13104	12784	106	45
	1479	1704	1268	1457					5944	6462	2692	1143
RTAC 200 HIGH	3632	4187	3110	3578	NA	NA	NA	NA	14593	14247	124	45
	1648	1899	1411	1623					6619	6518	3150	1143
RTAC 225 STD	3632	4229	3114	3632	NA	NA	NA	NA	14687	14370	124	45
	1647	1918	1413	1647					6662	7184	3150	1143
RTAC 225 HIGH	2569	2892	2477	2800	2388	2711	NA	NA	16184	15838	166	44
	1165	1312	1124	1270	1083	1230			7341	6580	4216	1118
RTAC 250 STD	3691	4165	3088	3562	NA	NA	NA	NA	14853	14507	124	45
	1674	1889	1401	1616					6737	7243	3150	1143
RTAC 250 HIGH	2601	2897	2512	2808	2427	2723	NA	NA	16314	15968	166	44
	1180	1314	1140	1274	1101	1235			7400	8562	4216	1118
RTAC 275 STD	3345	2936	3351	2942	3356	2947	NA	NA	19536	18876	176	42
	1517	1332	1520	1334	1522	1337			8862	9193	4470	1067
RTAC 275 HIGH	3251	2863	3571	3183	3894	3505	NA	NA	20944	20266	203	42
	1475	1299	1620	1444	1766	1590			9500	9319	5156	1067
RTAC 300 STD	3456	3074	3615	3233	3774	3393	NA	NA	21103	20544	222	42
	1568	1394	1640	1466	1712	1539			9572	10210	5639	1067
RTAC 300 HIGH	2955	2628	2892	2565	2782	2495	2759	2432	22060	22508	222	42
	1340	1192	1312	1163	1262	1132	1251	1103	10006	9730	5639	1067
RTAC 350 STD	3374	2998	3772	3367	4172	3767	NA	NA	21904	21450	205	42
	1530	1360	1711	1527	1892	1709			9936	10797	5207	1067

Notes:

1. Operating weight includes refrigerant and water.
2. Shipping weight includes refrigerant.
3. All weights +/- 3%.

Unit Top (Plan) View

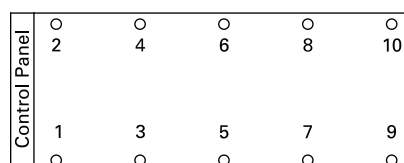

Unit Top (Plan) View

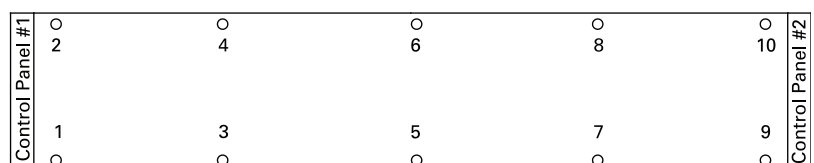

Installation Mechanical

Isolation and Sound Emission

The most effective form of isolation is to locate the unit away from any sound sensitive area. Structurally transmitted sound can be reduced by elastomeric vibration eliminators. Spring isolators are not recommended. Consult an acoustical engineer in critical sound applications.

For maximum isolation effect, isolate water lines and electrical conduit. Wall sleeves and rubber isolated piping hangers can be used to reduce the sound transmitted through water piping.

To reduce the sound transmitted through electrical conduit, use flexible electrical conduit.

State and local codes on sound emissions should always be considered. Since the environment in which a sound source is located affects sound pressure, unit placement must be carefully evaluated. Sound power levels for Trane air-cooled Series R® chillers are available on request.

Fig. III-04 – Unit Isolator Locations

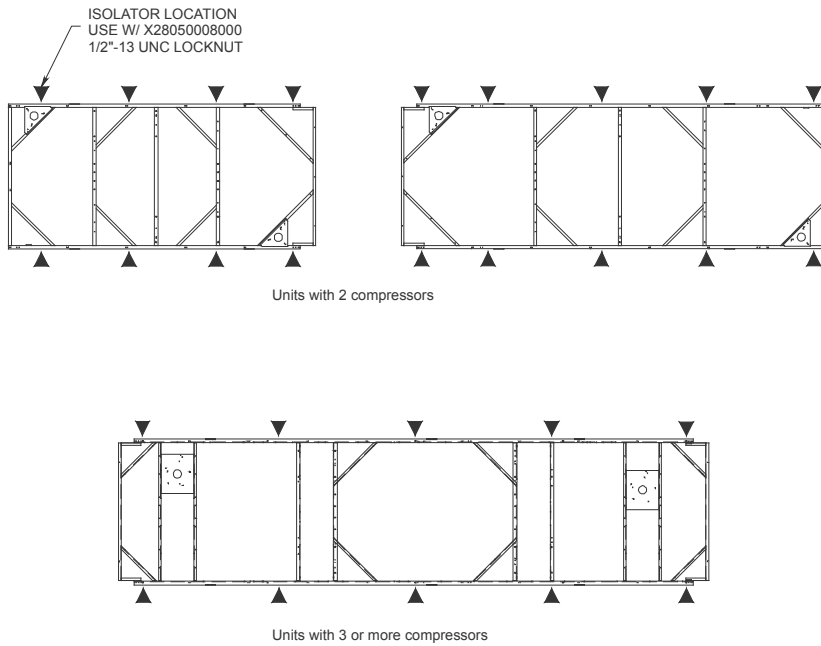

Ton	Efficiency	Hz	Insulator Quantity	Cantidad
140	STD	60	X101403 1503	8
	High	60	X101403 1503	8
155	STD	60	X101403 1503	8
	High	60	X101403 1503	8
170	STD	60	X101403 1503	8
	High	60	X101403 1503	8
185	STD	60	X101403 1503	8
	High	60	X101403 1503	10
200	STD	60	X101403 1503	8
	High	60	X101403 1503	10
225	STD	60	X101403 1503	10
	High	60	X101403 1503	10
250	STD	60	X101403 1503	10
	High	60	X101403 1503	10
275	STD	60	X101403 1503	10
	High	60	X101403 1503	10
300	STD	60	X101403 1503	10
	High	60	X101403 1503	10
350	STD	60	X101403 1503	10

Installation Mechanical

Foundation

Provide rigid, non-warping mounting pads or a concrete foundation of sufficient strength and mass to support the outdoor unit operating weight (i.e., including completed piping, and full operating charges of refrigerant, oil and water). Refer to Tables in the General Information section for unit operating weights. Once in place, the outdoor unit must be level within 1/4" (6 mm) over its length and width.

The Trane Company is not responsible for equipment problems resulting from an improperly designed or constructed foundation.

NOTE: To allow for cleaning under the condensing coil, it is recommended that an opening be left between the unit base and the concrete pad.

Clearances

Provide enough space around the outdoor unit to allow the installation and maintenance personnel unrestricted access to all service points. Refer to submittal drawings

for the unit dimensions. A minimum of 4 feet (1.2 m) is recommended for compressor service. Provide sufficient clearance for the opening of control panel doors. Refer to Figure 18 through Figure 19 for minimum clearances. In all cases, local codes which require additional clearances will take precedence over these recommendations.

Fig. III-05 – Recommended Unit Clearances 15-foot bases

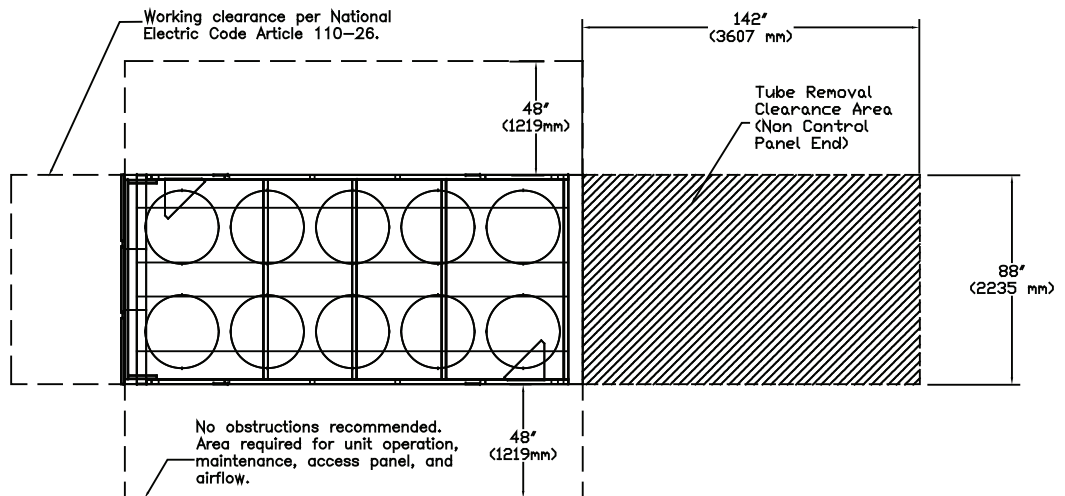

Installation Mechanical

Fig. III-06 – Recommended Unit Clearances 18-21 foot bases

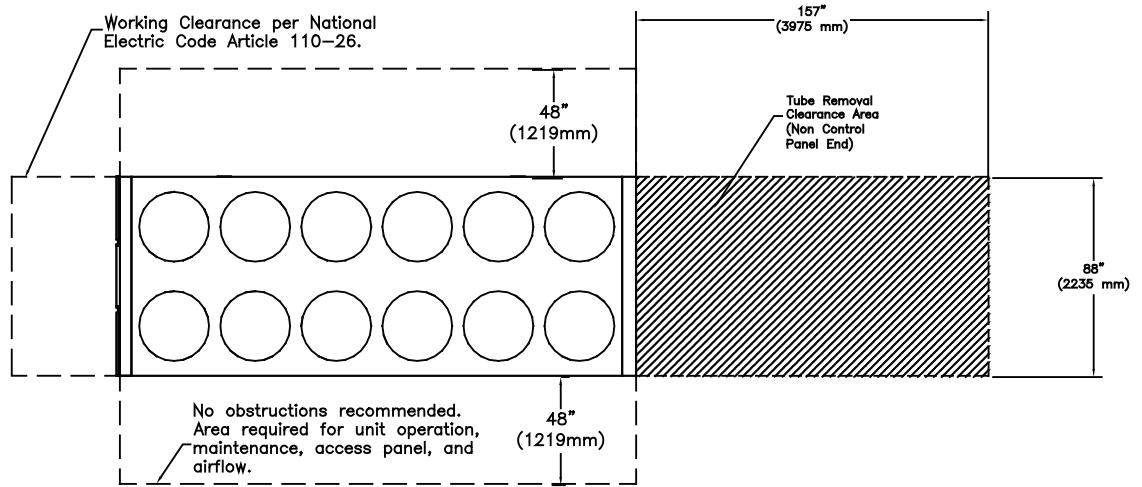
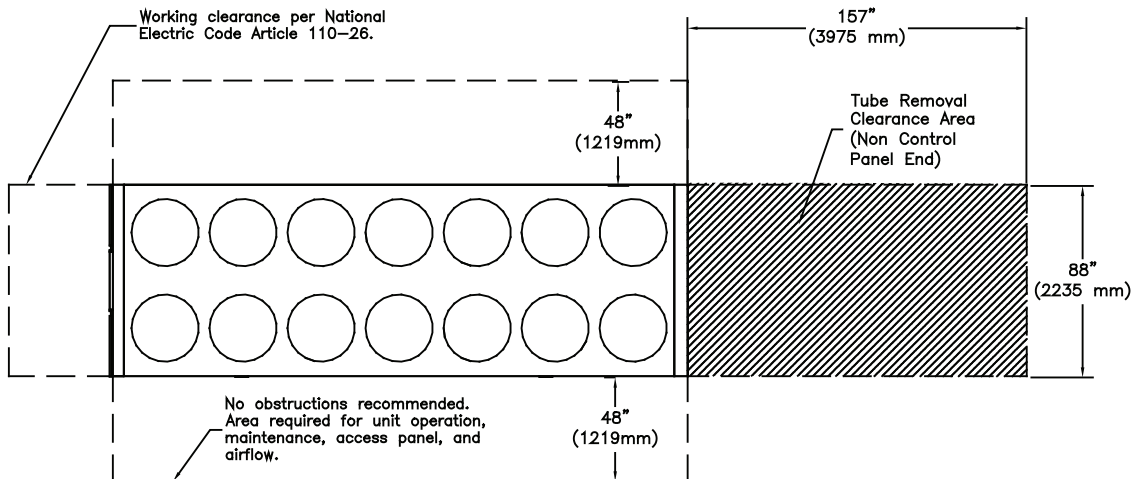

Fig. III-07 – Recommended Unit Clearances 30-45 foot bases



Installation Mechanical

Debris, trash, supplies etc. should not be allowed to accumulate in the vicinity of the unit. Supply air movement may draw debris into the condenser coil, blocking spaces between coil fins and causing coil starvation. Special consideration should be given to low ambient units. Condenser coils and fan discharge must be kept free of snow or other obstructions to permit adequate airflow for satisfactory unit operation.

In situations where equipment must be installed with less clearance than recommended, such as frequently occurs in retrofit and rooftop applications, restricted air-flow is common. The Main Processor will direct the unit to make as much chilled water as possible given the actual installed conditions. Consult your Trane sales engineer for more details.

NOTE: If the outdoor unit configuration requires a variance to the clearance dimensions, contact your Trane Sales Office Representative. Also refer to Trane Engineering Bulletins for application information on RTAC chillers.

Unit Isolation and Leveling

For additional reduction of sound and vibration, install the optional neoprene isolators.

Construct an isolated concrete pad for the unit or provide concrete footings at the unit mounting points. Mount the unit directly to the concrete pads or footings.

Level the unit using the base rail as a reference. The unit must be level within 1/4-in (6 mm) over the entire length and width. Use shims as

Neoprene Isolator Installation

1. Secure the isolators to the mounting surface using the mounting slots in the isolator base plate. Do not fully tighten the isolator mounting bolts at this time.

2. Align the mounting holes in the base of the unit with the threaded positioning pins on the top of the isolators.

3. Lower the unit onto the isolators and secure the isolator to the unit with a nut. Maximum isolator deflection should be 1/4 inch (6 mm).

4. Level the unit carefully. Fully tighten the isolator mounting bolts.

Drainage

Provide a large capacity drain for water vessel drain-down during shutdown or repair. The evaporator is provided with a drain connection. All local and national codes apply. The vent on the top of the evaporator waterbox is provided to prevent a vacuum by allowing air into the evaporator for complete drainage.

Evaporator Water Piping

Thoroughly flush all water piping to the unit before making the final piping connections to the unit.

Evaporator Piping

Components and layout will vary slightly, depending on the location of connections and the water source.

CAUTION

Evaporator Damage!

The chilled water connections to the evaporator are to be “victaulic” type connections. Do not attempt to weld these connections, as the heat generated from welding can cause microscopic and macroscopic fractures on the cast iron waterboxes that can lead to premature failure of the waterbox. To prevent damage to chilled water components, do not allow evaporator pressure (maximum working pressure) to exceed 150 psig (10.5 bar).



Installation Mechanical

Provide shutoff valves in lines to the gauges to isolate them from the system when they are not in use. Use rubber vibration eliminators to prevent vibration transmission through the water lines. If desired, install thermometers in the lines to monitor entering and leaving water temperatures. Install a balancing valve in the leaving water line to control water flow balance. Install shutoff valves on both the entering and leaving water lines so that the evaporator can be isolated for service.

CAUTION

Use Piping Strainers!

To prevent evaporator damage, pipe strainers must be installed in the water supplies to protect components from water born debris. Trane is not responsible for equipment-only-damage caused by water born debris.

“Piping components” include all devices and controls used to provide proper water system operation and unit operating safety. These components and their general locations are given below.

Entering Chilled Water Piping

- Air vents (to bleed air from system).
- Water pressure gauges with shutoff valves.
- Vibration eliminators.
- Shutoff (isolation) valves.
- Thermometers (if desired).
- Clean-out tees.
- Pipe strainer.

Leaving Chilled Water Piping

- Air vents (to bleed air from system).
- Water pressure gauges with shutoff valves. Vibration eliminators.
- Shutoff (isolation) valves.
- Thermometers.
- Clean-out tees.
- Balancing valve.
- Flow Switch

Evaporator Drain

A 1/2 inch drain connection is located under the outlet end of the evaporator waterbox.

This may be connected to a suitable drain to permit evaporator drainage during unit servicing. A shutoff valve must be installed on the drain line.

Evaporator Flow Switch

Specific connection and schematic wiring diagrams are shipped with the unit. Some piping and control schemes, particularly those using a single water pump for both chilled and hot water, must be analyzed to determine how and or if a flow sensing device will provide desired operation.

Follow the manufacturer's recommendations for selection and installation procedures. General guidelines for flow switch installation are outlined below

1. Mount the switch upright, with a minimum of 5 pipe diameters of straight horizontal run on each side. Do not install close to elbows, orifices or valves.

NOTE: The arrow on the switch must point in the direction of flow.

2. To prevent switch fluttering, remove all air from the water system.

NOTE: The CH530 provides a 6-second time delay after a “loss-of-flow” diagnostic before shutting the unit down. Contact a qualified service representative if nuisance machine shutdowns persist.

3. Adjust the switch to open when water flow falls below the minimum flow rate. Evaporator data is given in the General Information section. Flow switch contacts are closed on proof of water flow.

4. Install a pipe strainer in the entering evaporator water line to protect components from waterborne debris.

Installation Mechanical

Evaporator Water Pressure Drop RTAC 140 - 250 Ton

Fig. III-08 – Evaporator Water Pressure Drop

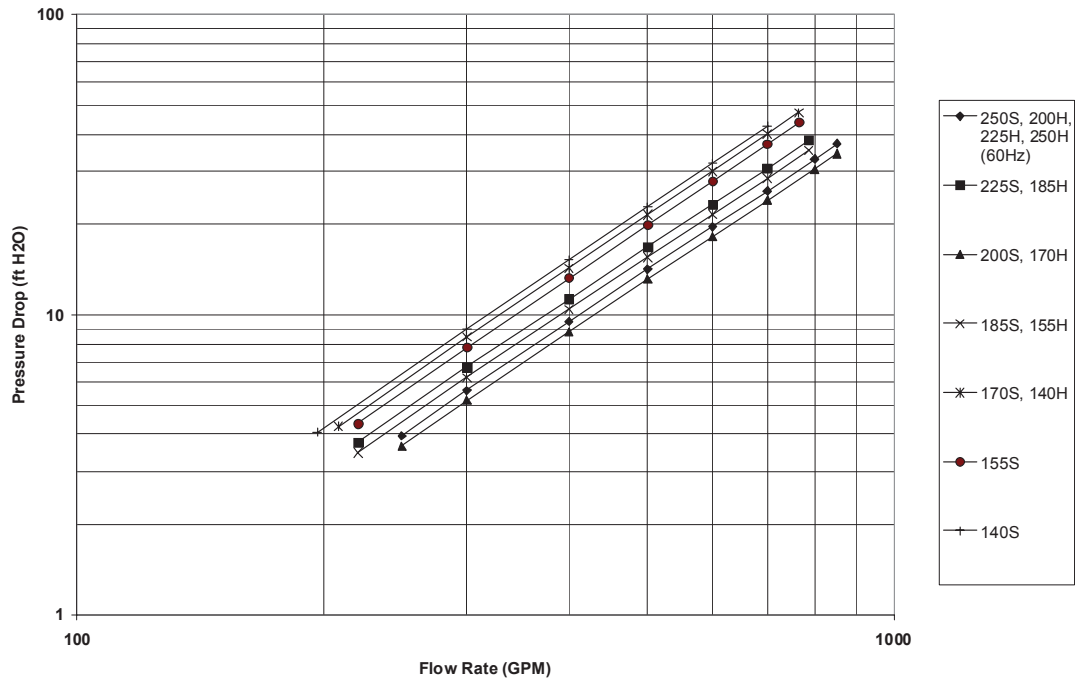
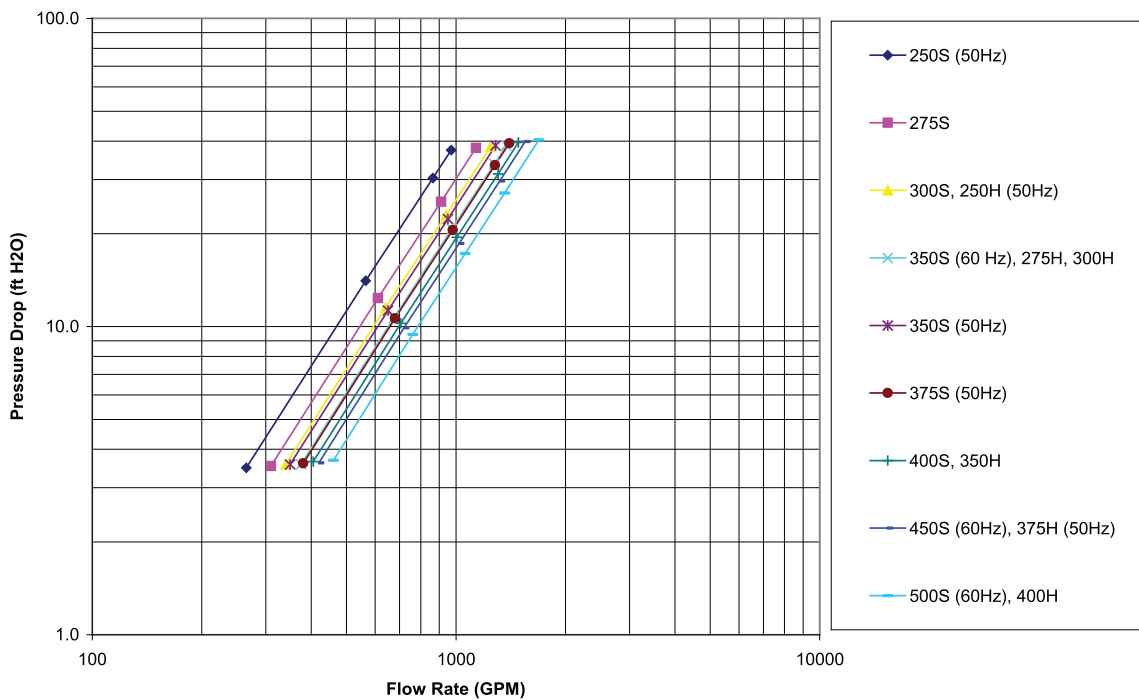

Fig. III-09 – Evaporator Water Pressure Drop

Water-Side Pressure Drop vs Flow Rate



Installation Mechanical

CAUTION

Proper Water Treatment!

The use of untreated or improperly treated water in a unit may result in scaling, erosion, corrosion, algae or slime. It is recommended that the services of a qualified water treatment specialist be engaged to determine what water treatment, if any, is required. Trane assumes no responsibility for equipment failures which result from untreated or improperly treated water, or saline or brackish water.

If using an acidic commercial flushing solution, construct a temporary bypass around the unit to prevent damage to internal components of the evaporator.

Dirt, scale, products of corrosion and other foreign material will adversely affect heat transfer between the water and system components. Foreign matter in the chilled water system can also increase pressure drop and, consequently, reduce water flow. Proper water treatment must be determined

locally, depending on the type of system and local water characteristics. el establecimiento de un programa adecuado para el tratamiento del agua.

La utilización en estas unidades de agua no tratada o tratada de manera inadecuada puede provocar un funcionamiento ineficiente y posibles daños a los tubos. Consultar a un especialista calificado en tratamiento de agua para determinar si es necesario tal tratamiento. La siguiente etiqueta de exención de responsabilidad está presente en cada unidad RTAC:

Neither salt nor brackish water is recommended for use in Trane air-cooled Series R® chillers. Use of either will lead to a shortened life to an indeterminable degree. The Trane Company encourages the employment of a reputable water treatment specialist, familiar with local water conditions, to assist in this determination and in the establishment of a proper water treatment program.

Using untreated or improperly treated water in these units may result in inefficient operation and possible tube

damage. Consult a qualified water treatment specialist to determine whether treatment is needed. The following disclamatory label is provided on each RTAC unit:

NOTE: The use of improperly treated or untreated water in this equipment may result in scaling, erosion, corrosion, algae or slime. The services of a qualified water treatment specialist should be engaged to determine what treatment, if any, is advisable. The Trane Company warranty specifically excludes liability for corrosion, erosion or deterioration of Trane equipment.

Water Pressure Gauges

Install field-supplied pressure components as shown in Figure 25. Locate pressure gauges or taps in a straight run of pipe; avoid placement near elbows, etc. Be sure to install the gauges at the same elevation on each shell if the shells have opposite endwater connections.

Fig. III-10 – Evaporator Water Pressure Drop

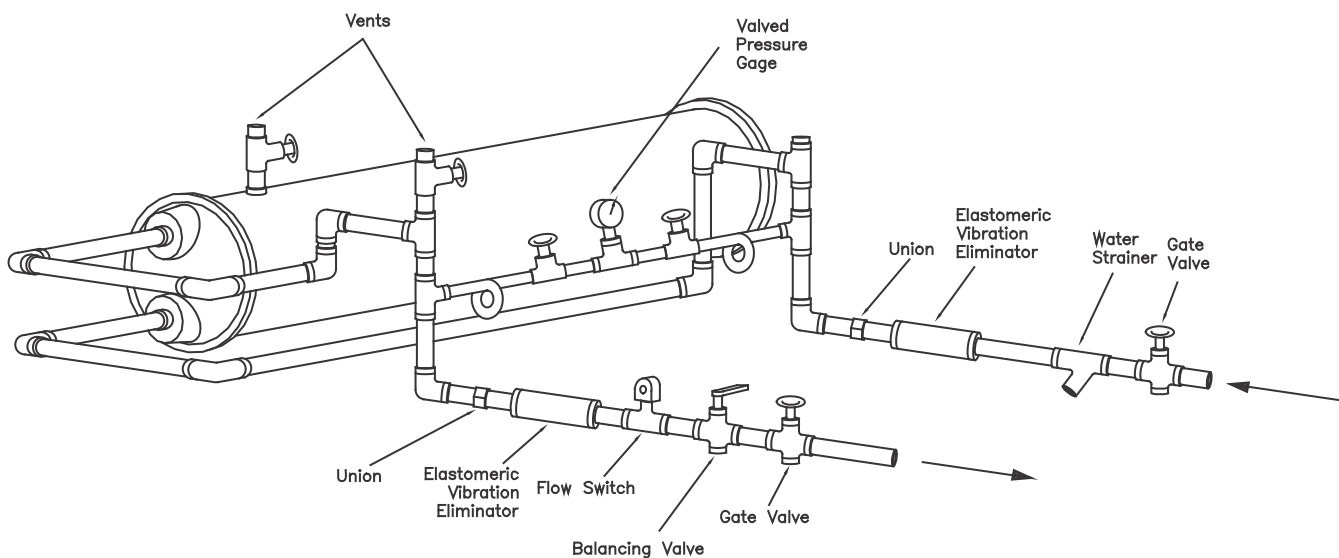

NOTE: Once the unit is installed at a site, one vertical or one diagonal unit support can be permanently removed if it creates an obstruction for water piping.

To read manifolded pressure gauges, open one valve and close the other (depending upon the reading desired). This eliminates errors resulting from differently calibrated gauges installed at unmatched elevations.

Installation Mechanical

Water Pressure Relief Valves

CAUTION

Shell Damage!

To prevent shell damage, install pressure relief valves in the evaporator water system.

Install a water pressure relief valve in the evaporator inlet piping between the evaporator and the inlet shutoff valve, as shown. Water vessels with close-coupled shutoff valves have a high potential for hydrostatic pressure buildup on a water temperature increase. Refer to applicable codes for relief valve installation guidelines.

Freeze Protection

If the unit will remain operational at subfreezing ambient temperatures, the chilled water system must be protected from freezing. Heaters are factory-installed on the packaged unit evaporator and will help protect it from freezing in ambient temperatures down to -20°F (-29°C).

Install heat tape on all water piping, pumps, water box nozzles and other components that may be damaged if exposed to freezing temperatures. Heat tape must be designed for low ambient temperature applications. Heat tape selection should be based on the lowest expected ambient temperature.

Add a non-freezing, low temperature, corrosion inhibiting, heat transfer fluid may also be added to the chilled water system. The solution must be strong enough to provide protection against ice formation at the lowest anticipated ambient temperature. Refer to Table in the General Information section for evaporator water storage capacities.

NOTE: Use of glycol type antifreeze reduces the cooling capacity of the unit and must be considered in the design of the system specifications.

CAUTION

Evaporator Damage!

ALL unit chilled water pumps must be controlled by the Trane CH530 to avoid catastrophic damage to the evaporator due to freezing. Refer to RLC-PRB012-EN.

Low Evaporator Refrigerant Cutout and % Glycol Recommendations

1. Solution freeze point is 4 deg F below operating point saturation temperature.
2. LRTC is 4 deg F below freeze point.

Procedure

1. Is operating condition contained within Table? If no see "Special" below.
2. For leaving fluid temperatures greater than 40 deg F, use settings for 40 deg F.
3. Select operating conditions from Table.
4. Read off recommended % glycol.
5. Go to Table from the % glycol.

Important

1. Additional glycol beyond the recommendations will adversely effect unit performance. The unit efficiency will be reduced and the saturated evaporator temperature will be reduced. For some operating conditions this effect can be significant.
2. If additional glycol is used, then use the actual % glycol to establish the low refrigerant cutout setpoint.
3. The minimum low refrigerant cutout setpoint allowed is 5 deg F. The minimum is established by the solubility limits of the oil in the refrigerant.

Specials

The following constitute a special that must be calculated by engineering:

1. Freeze inhibitor other than Ethylene Glycol or Propylene Glycol.
2. Fluid delta T outside the range 4 to 16 deg F.
3. Unit configuration other than Standard, Standard with extra pass, and Premium.
4. % Glycol greater than maximum in column in Table.

Special should all be calculated by engineering. The purpose of calculating is to make sure that design saturation temperature is greater than 3 deg F. Additionally, the calculation must verify that the fluid freeze point is a minimum of 4 deg. F lower that the design saturation temperature. The low evaporator temperature cutout will be 4 deg F below the freeze point or 5 deg F, whichever is greater.



Installation Mechanical

Tab. III-03 – Glycol Recommendations

	Ethylene Glycol								Propilenglicol							
	DT	4	6	8	10	12	14	16	4	6	8	10	12	14	16	
	[F]	[C]	-15	-14	-13	-12	-11	-10	-9	-15	-14	-13	-12	-11	-10	-9
Leaving Water Temperature (F/C)	38		-	5	5	5	5	6	-	-	6	6	7	7	8	-
	34		-	11	11	11	12	-	-	-	13	13	15	17	-	-
	30		-	15	16	17	18	-	-	-	19	21	-	-	-	-
	28		-	18	18	19	-	-	-	-	22	-	-	-	-	-
	26		-	20	21	22	-	-	-	-	25	-	-	-	-	-
	24		-	22	23	26	-	-	-	-	-	-	-	-	-	-
	22		-	24	26	-	-	-	-	-	-	-	-	-	-	-
	20		-	26	30	-	-	-	-	-	-	-	-	-	-	-
	18		-	29	-	-	-	-	-	-	-	-	-	-	-	-
	16		-	31	-	-	-	-	-	-	-	-	-	-	-	-
	14		30	-	-	-	-	-	-	-	-	-	-	-	-	-
	12		32	-	-	-	-	-	-	-	-	-	-	-	-	-
10,4		34	-	-	-	-	-	-	-	-	-	-	-	-	-	
-12																

These tables represent the MINIMUM RECOMMENDED glycol percentages for each operating condition

Operation is not recommended at certain operating conditions as some chillers may not satisfy maximum or minimum velocity requirements or minimum performance requirements. Contact Trane Sales Representative for more information regarding the operating limits of a particular chiller.

Tab. III-04 – Recommended Low Evaporator Refrigerant Cutout and % Glycol

% Glycol	Ethylene Glycol				Propylene			
	Low Refrig. Temp Cutout		Solution Freeze Point		Low Refrig. Temp Cutout		Solution Freeze Point	
	°F	°C	°F	°C	°F	°C	°F	°C
0	28,0	-2,2	32,0	0,0	28,0	-2,2	32,0	0,0
5	25,0	-3,9	29,0	-1,7	25,3	-3,7	29,3	-1,5
10	21,5	-5,8	25,5	-3,6	22,4	-5,3	26,4	-3,1
15	17,5	-8,1	21,5	-5,8	19,1	-7,2	23,1	-4,9
20	12,8	-10,7	16,8	-8,4	15,3	-9,3	19,3	-7,1
25	7,4	-13,7	11,4	-11,4	10,8	-11,8	14,8	-9,6
30	1,1	-17,2	5,1	-15,0	5,3	-14,8	9,3	-12,6
35	-5,0	-20,6	-2,3	-19,1	-1,3	-19,5	2,7	-16,3
40	-5,0	-20,6	-10,8	-23,8	-5,0	-20,6	-5,2	-20,7
45	-5,0	-20,6	-20,7	-29,3	-5,0	-20,6	-14,6	-25,9
50	-5,0	-20,6	-32,1	-35,6	-5,0	-20,6	-25,8	-32,1
54	-5,0	-20,6	-42,3	-41,3	-5,0	-20,6	-36,1	-37,8

Chilled Water Temperature Cutout should be set to 5°F below the lowest allowable Chilled Water Set Point bases on the %Glycol.

IV-Installation Electrical

General Recommendations

All wiring must comply with local codes and the National Electric Code. Typical field wiring diagrams are included at the end of the manual. Minimum circuit ampacities and other unit electrical data are on the unit nameplate. See the unit order specifications for actual electrical data. Specific electrical schematics and connection diagrams are shipped with the unit.

Do not allow conduit to interfere with other components, structural members or equipment. Control voltage (115V) wiring in conduit must be separate from conduit carrying low voltage (<30V) wiring.

Caution: To prevent control malfunctions, do not run low voltage wiring (<30V) in conduit with conductors carrying more than 30 volts.

WARNING

Hazardous Voltage w/Capacitors!

Disconnect all electric power, including remote disconnects before servicing. Follow proper lockout/tagout procedures to ensure the power cannot be inadvertently energized. For variable frequency drives or other energy storing components provided by Trane or others, refer to the appropriate manufacturer's literature for allowable waiting periods for discharge of capacitors. Verify with an appropriate voltmeter that all capacitors have discharged. Failure to disconnect power and discharge capacitors before servicing could result in death or serious injury.

Note: For additional information regarding the safe discharge of capacitors, see PROD-SVB06A-EN or PROD-SVB06A-FR

CAUTION

Use Copper Conductors Only!

Unit terminals are not designed to accept other types of conductors. Failure to use copper conductors may result in equipment damage. Important!



Installation Electrical

Installer-Supplied Components

Customer wiring interface connections are shown in the electrical schematics and connection diagrams that are shipped with the unit. The installer must provide the following components if not ordered with the unit:

- Power supply wiring (in conduit) for all field-wired connections.
- All control (interconnecting) wiring (in conduit) for field supplied devices.
- Fused disconnect switches or circuit breakers.
- Power factor correction capacitors. (optional)

Power Supply Wiring

All power supply wiring must be sized and selected accordingly by the project engineer in accordance with NEC Table 310-16.

WARNING

Hazardous Voltage w/Capacitors!

Disconnect all electric power, including remote disconnects before servicing. Follow proper lockout/tagout procedures to ensure the power cannot be inadvertently energized. For variable frequency drives or other energy storing components provided by Trane or others, refer to the appropriate manufacturer's literature for allowable waiting periods for discharge of capacitors. Verify with an appropriate voltmeter that all capacitors have discharged. Failure to disconnect power and discharge capacitors before servicing could result in death or serious injury.

Note: For additional information regarding the safe discharge of capacitors, see PROD-SVB06A-EN or PROD-SVB06A-FR

All wiring must comply with local codes and the National Electrical Code. The installing (or electrical) contractor must provide and install the system interconnecting wiring, as well as the power supply wiring. It must be properly sized and equipped with the appropriate fused disconnect switches.

The type and installation location(s) of the fused disconnects must comply with all applicable codes.

CAUTION

Use Copper Conductors Only!

Unit terminals are not designed to accept other types of conductors. Failure to use copper conductors may result in equipment damage.

Cut holes into the sides of the control panel for the appropriately-sized power wiring conduits. The wiring is passed through these conduits and connected to the terminal blocks, optional unit-mounted disconnects, or HACR type breakers. Refer to Figure31.

To provide proper phasing of 3-phase input, make connections as shown in field wiring diagrams and as stated on the WARNING label in the starter panel. For additional information on proper phasing, refer to "Unit Voltage Phasing." Proper equipment ground must be provided to each ground connection in the panel (one for each customer-supplied conductor per phase).

Installation Electrical

115 volt field-provided connections (either control or power) are made through knockouts on the lower left side of the panel. Additional grounds may be required for each 115 volt power supply to the unit. Green lugs are provided for 115V customer wiring.

Fig. IV-01 – Starter Panel RTAC 140-350

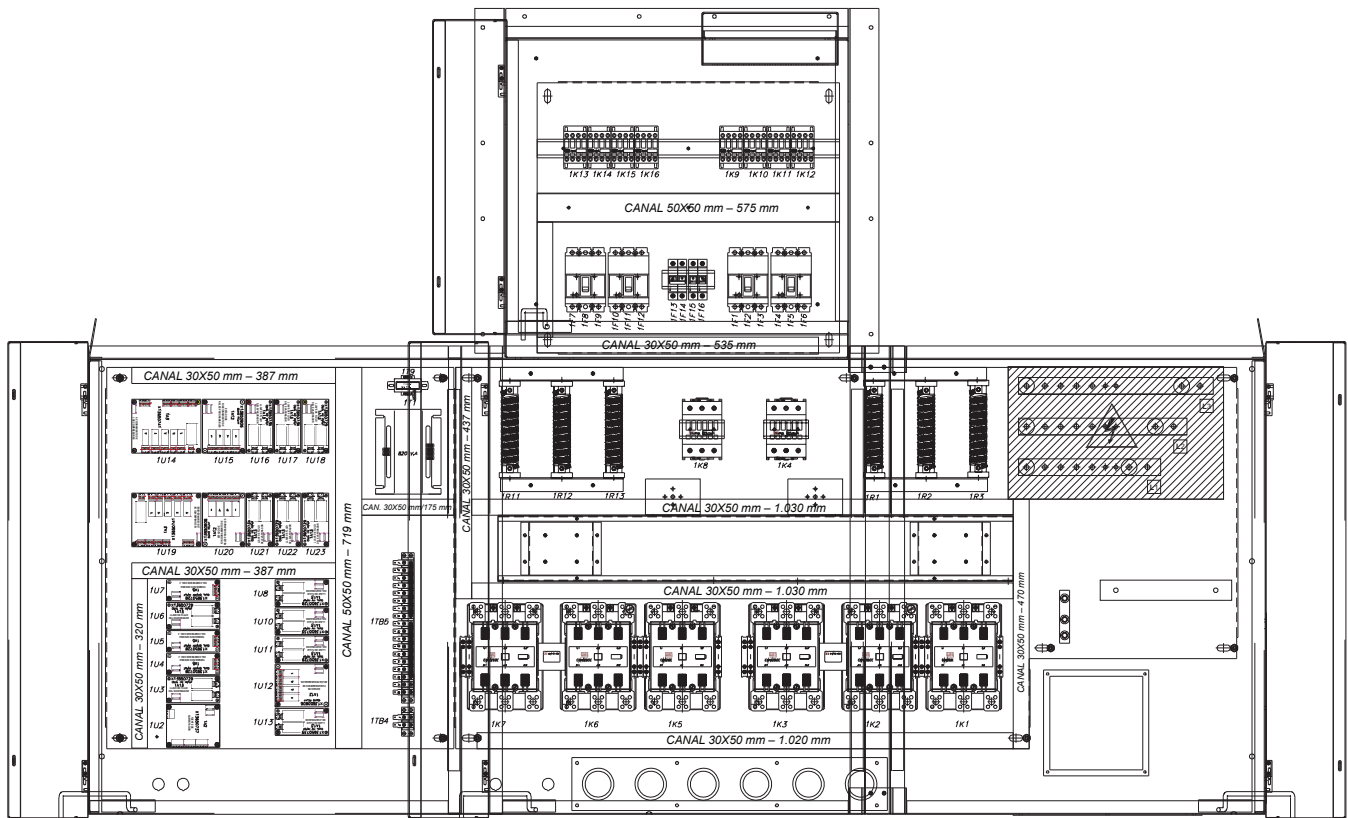

Installation Electrical

Fig. IV-02 – Startup Panel Channel Control Panel for the Low Temperature option RTAC 140-350.

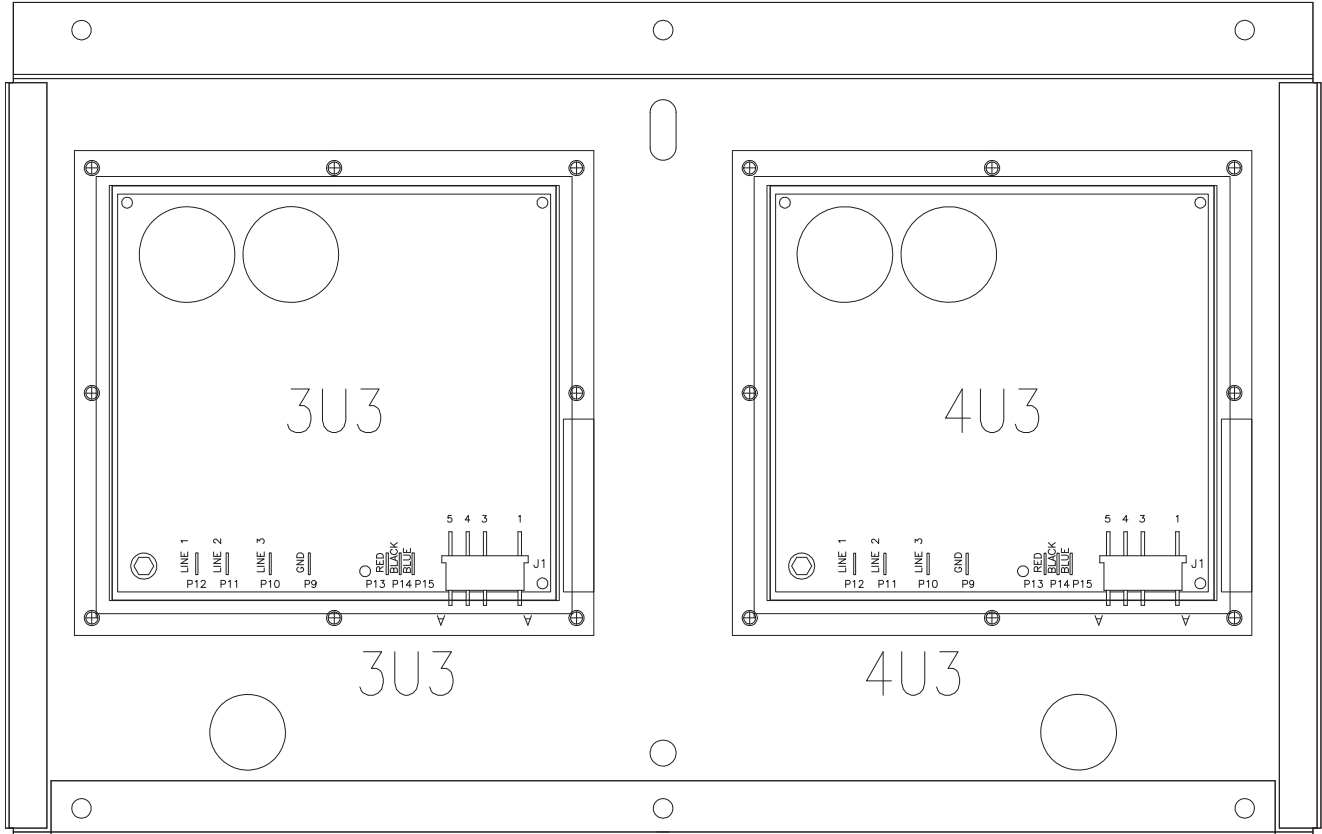

Installation Electrical

Control Power Supply

The unit is equipped with a control power transformer; it is not necessary to provide additional control power voltage to the unit. All units are factory-connected for appropriate labeled voltages except for the 400V/50Hz units which need the control power transformer (1T1) reconnected as noted below.

NOTE: Important! As shipped, a normal 400 volt unit control power transformer is wired on the 400 volt tap (H3). Reconnect the appropriate transformer wire lead 126A to the tap (H2) for 380V/50Hz power supply or lead 126A to the tap H4 for the 415V/50 Hz power supply. It is also necessary to adjust the "unit voltage" setting using TechView (Configuration-Custom Tab).

Heater Power Supply and Convenience Outlet (Packaged Units Only)

The evaporator shell is insulated from ambient air and protected from freezing temperatures by two thermostatically-controlled immersion heaters and two strip heaters. Whenever the water temperature drops to approximately 37°F (2.8°C), the thermostat energizes the heaters. The heaters will provide protection from ambient temperatures down to -20°F (-29°C).

It is required to provide an independent power source (115V 60Hz-20 amp, 220V 50Hz-15 amp), with a fused-disconnect. The heaters are factory-wired back to the unit control panel.

CAUTION Heat Tape!

Control panel main processor does not check for loss of power to the heat tape nor does it verify thermostat operation. A qualified technician must verify power to the heat tape and confirm operation of the heat tape thermostat to avoid catastrophic damage to the evaporator.

Interconnecting Wiring

Chilled Water Flow (Pump) Interlock

The Model RTAC Series R® chiller requires a field-supplied control voltage contact input through a flow proving switch 5S1 and an auxiliary contact 5K1 AUX. Connect the proving switch and auxiliary contact to 1TB5-8 and 1U11 J3-2. Refer to the field wiring for details. The auxiliary contact can be BAS signal, starter contactor auxiliary, or any signal which indicates the pump is running. A flow switch is still required and cannot be omitted.

Chilled Water Pump Control

An evaporator water pump output relay closes when the chiller is given a signal to go into the Auto mode of operation from any source. The contact is opened to turn off the pump in the event of most machine level diagnostics to prevent the build up of pump heat.

CAUTION

Evaporator Damage!

IMPORTANT: ALL unit chilled water pumps must be controlled by the Trane CH530 to avoid catastrophic damage to the evaporator due to freezing. Refer to RLC-PRB012-EN.

The relay output from 1U10 is required to operate the Evaporator Water Pump (EWP) contactor. Contacts should be compatible with 115/240 VAC control circuit. The EWP relay operates in different modes depending on CH530 or Tracer commands, if available, or service pumpdown (See maintenance section). Normally, the EWP relay follows the AUTO mode of the chiller.

Whenever the chiller has no diagnostics and is in the AUTO mode, regardless of where the auto command is coming from, the normally open relay is energized. When the chiller exits the AUTO mode, the relay is timed open for an adjustable (using TechView) 0 to 30 minutes. The non-AUTO modes in which the pump is stopped, include Reset (88), Stop (00), External Stop (100), Remote Display Stop (600), Stopped by Tracer (300), Low Ambient Run Inhibit (200), and Ice Building complete (101).

Regardless of whether the chiller is allowed to control the pump on a full-time basis, if the MP calls for a pump to start and water does not flow, the evaporator may be damaged catastrophically. It is the responsibility of the installing contractor and/or the customer to ensure that a pump will start when called upon by the chiller controls.



Installation Electrical

Tab. IV-01 – Pump Relay Operation

Chiller Mode	Relay Operation
Auto	Instant close Ice Building
Instant close Tracer Override	Close
Stop	Timed Open
Ice Complete	Instant Open
Diagnostics	Instant Open

NOTE: Exceptions are listed below.

When going from Stop to Auto, the EWP relay is energized immediately. If evaporator water flow is not established in 4 minutes and 15 sec., the CH530 de-energizes the EWP relay and generates a non-latching diagnostic. If flow returns (e.g. someone else is controlling the pump), the diagnostic is cleared, the EWP is re-energized, and normal control resumed.

If evaporator water flow is lost once it had been established, the EWP relay remains energized and a non-latching diagnostic is generated. If flow returns, the diagnostic is cleared and the chiller returns to normal operation.

In general, when there is either a non-latching or latching diagnostic, the EWP relay is turned off as though there was a zero time delay. Exceptions (see above table) whereby the relay continues to be energized occur with:

A Low Chilled Water Temp. diagnostic (non-latching) (unless also accompanied by an Evap Leaving Water Temperature Sensor Diagnostic)

or

A starter contactor interrupt failure diagnostic, in which a compressor continues to draw current even after commanded to have shutdown

or

A Loss of Evaporator Water Flow diagnostic (non-latching) and the unit is in the AUTO mode, after initially having proven evaporator water flow.

Alarm and Status Relay Outputs (Programmable Relays)

A programmable relay concept provides for enunciation of certain events or states of the chiller, selected from a list of likely needs, while only using four physical output relays, as shown in the field wiring diagram. The four relays are provided (generally with a Quad Relay Output LLID) as part of the Alarm Relay Output Option. The relay's contacts are isolated Form C (SPDT), suitable for use with 120 VAC circuits drawing up to 2.8 amps inductive, 7.2 amps resistive, or 1/3 HP and for 240 VAC circuits drawing up to 0.5 amp resistive.

The list of events/states that can be assigned to the programmable relays can be found in Table. The relay will be energized when the event/state occurs.



Installation Electrical

Tab. IV-02 – Pump Relay Operation

Chiller Mode	Relay Operation
Alarm - Latching	This output is true whenever there is any active diagnostic that requires a manual reset to clear, that affects either the Chiller, the Circuit, or any of the Compressors on a circuit. This classification does not include informational diagnostics.
Alarm - Auto Reset	This output is true whenever there is any active diagnostic that could automatically clear, that affects either the Chiller, the Circuit, or any of the Compressors on a circuit. This classification does not include informational diagnostics.
Alarm	This output is true whenever there is any diagnostic affecting any component, whether latching or auto- matically clearing. This classification does not include informational diagnostics
Alarm Ckt 1	This output is true whenever there is any diagnostic effecting Refrigerant Circuit 1, whether latching or automatically clearing, including diagnostics affecting the entire chiller. This classification does not include informational diagnostics.
Alarm Ckt 2	This output is true whenever there is any diagnostic affecting Refrigerant Circuit 2 whether latching or automatically clearing, including diagnostics effecting the entire chiller. This classification does not include informational diagnostics.
Chiller Limit Mode	This output is true whenever the chiller has been running in one of the Unloading types of limit modes (with a 20 minute fil- (Condenser, Evaporator, Current Limit or Phase Imbalance Limit) continuously for the last 20 minutes. ter)
Circuit 1 Running	This output is true whenever any compressors are running (or commanded to be running) on Refrigerant
Circuit 2 Running	This output is true whenever any compressors are running (or commanded to be running) on Refrigerant
Chiller Running	This output is true whenever any compressors are running (or commanded to be running) on the chiller and false when no compressors are commanded to be running on the chiller.
Maximum Capacity (software or later)	This output is true whenever the chiller has reached maximum capacity or had reached its 18.0 maximum capacity and since that time has not fallen below 70% average current relative to the rated ARI current for the chiller. The output is false when the chiller falls below 70% average current and, since that time, had not reestablished maximum capacity.

Relay Assignments Using TechView

CH530 Service Tool (TechView) is used to install the Alarm and Status Relay Option package and assign any of the above list of events or status to each of the four relays provided with the option.

The relays to be programmed are referred to by the relay's terminal numbers on the LLID board 1U12.

The default assignments for the four available relays of the RTAC Alarm and Status Package Option are:



Installation Electrical

Tab. IV-03 – Pump Relay Operation

Relay 1 Terminals J2 -12,11,10:	Alarm
Relay 2 Terminals J2 - 9,8,7:	Chiller Running
Relay 3 Terminals J2-6,5,4:	Maximum Capacity (software 18.0 or later)
Relay 4 Terminals J2-3,2,1:	Chiller Limit

If any of the Alarm/Status relays are used, provide electrical power, 115 VAC with fused-disconnect to the panel and wire through the appropriate relays (terminals on 1U12 (EUR=A4-5)). Provide wiring (switched hot, neutral, and ground connections) to the remote annunciation devices. Do not use power from the chiller's control panel transformer to power these remote devices. Refer to the field diagrams which are shipped with the unit.

Low Voltage Wiring

The remote devices described below require low voltage wiring. All wiring to and from these remote input devices to the Control Panel must be made with shielded, twisted pair conductors. Be sure to ground the shielding only at the panel.

To prevent control malfunctions, do not run low voltage wiring (<30 V) in conduit with conductors carrying more than 30 volts.

Emergency Stop

CH530 provides auxiliary control for a customer specified/installed latching trip out. When this customer-furnished remote contact 5K14 is provided, the chiller will run normally when the contact is closed. When the contact opens, the unit will trip on a manually resettable diagnostic. This condition requires manual reset at the chiller switch on the front of the control panel.

Connect low voltage leads to terminal strip locations on 1U4. Refer to the field diagrams that are shipped with the unit.



Installation Electrical

Silver or gold-plated contacts are recommended. These customer-furnished contacts must be compatible with 24 VDC, 12 mA resistive load.

External Auto/Stop

If the unit requires the external Auto/Stop function, the installer must provide leads from the remote contacts 5K15 to the proper terminals of the LLID 1U4 on the control panel.

The chiller will run normally when the contacts are closed. When either contact opens, the compressor(s), if operating, will go to the RUN:UNLOAD operating mode and cycle off. Unit operation will be inhibited. Closure of the contacts will permit the unit to return to normal operation.

Field-supplied contacts for all low voltage connections must be compatible with dry circuit 24 VDC for a 12 mA resistive load. Refer to the field diagrams that are shipped with the unit.

External Circuit Lockout – Circuit #1 and Circuit #2

CH530 provides auxiliary control of a customer specified or installed contact closure, for individual operation of either Circuit #1 or #2. If the contact is closed, the refrigerant circuit will not operate 1K15 and 1K16.

Upon contact opening, the refrigerant circuit will run normally. This feature is used to restrict total chiller operation, e.g. during emergency generator operations.

Connections to 1U5 are shown in the field diagrams that are shipped with the unit. These customer-supplied contact closures must be compatible with 24 VDC, 12 mA resistive load. Silver or gold plated contacts are recommended.

Ice Building Option

CH530 provides auxiliary control for a customer specified/installed contact closure for ice building if so configured and enabled. This output is known as the Ice Building Status Relay. The normally open contact will be closed when ice building is in progress and open when ice building has been normally terminated either through Ice

Termination setpoint being reached or removal of the Ice Building command. This output is for use with the ice storage system equipment or controls (provided by others) to signal the system changes required as the chiller mode changes from “ice building” to “ice complete”. When contact 5K18 is provided, the chiller will run normally when the contact is open.

CH530 will accept either an isolated contact closure (External Ice Building command) or a Remote Communicated input (Tracer) to initiate and command the Ice Building mode.

CH530 also provides a “Front Panel Ice Termination Setpoint”, settable through TechView, and adjustable from 20 to 31°F (-6.7 to -0.5°C) in at least 1°F (1°C) increments.

NOTE: When in the Ice Building mode, and the evaporator entering water temperature drops below the ice termination setpoint, the chiller terminates the Ice Building mode and changes to the Ice Building Complete Mode.

CAUTION

Evaporator Damage!

Freeze inhibitor must be adequate for the leaving water temperature. Failure to do so will result in damage to system components.

Techview must also be used to enable or disable Ice Machine Control. This setting does not prevent the Tracer from commanding Ice Building mode.

Upon contact closure, the CH530 will initiate an ice building mode, in which the unit runs fully loaded at all times. Ice building shall be terminated either by opening the contact or based on the entering evaporator water temperature. CH530 will not



Installation Electrical

permit the ice building mode to be reentered until the unit has been switched out of ice building mode (open 5K18 contacts) and then switched back into ice building mode (close 5K18 contacts.)

In ice building, all limits (freeze avoidance, evaporator, condenser, current) will be ignored. All safeties will be enforced.

If, while in ice building mode, the unit gets down to the freeze stat setting (water or refrigerant), the unit will shut down on a manually resettable diagnostic, just as in normal operation.

Connect leads from 5K18 to the proper terminals of 1U7. Refer to the field diagrams which are shipped with the unit.

Silver or gold-plated contacts are recommended. These customer furnished contacts must be compatible with 24 VDC, 12 mA resistive load.

External Chilled Water Setpoint (ECWS) Option

The CH530 provides inputs that accept either 4-20 mA or 2-10 VDC signals to set the external chilled water setpoint (ECWS). This is not a reset function. The input defines the set point. This input is primarily used with generic BAS (building automation systems). The chilled water setpoint set via the DynaView or through digital communication with Tracer (Comm3). The arbitration of the various chilled water setpoint sources is described in the flow charts at the end of the section.

The chilled water setpoint may be changed from a remote location by sending either a 2-10 VDC or 4-20 mA signal to the 1U6, terminals 5 and 6 LLID. 2-10 VDC and 4-20 mA each correspond to a 10 to 65°F (-12 to 18°C) external chilled water setpoint.

The following equations apply:

	Voltage Signal	Current Signal
As generated from external source	$VDC=0.1455*(ECWS)+0.5454$	$mA=0.2909*(ECWS)+1.0909$
As processed by CH530	$ECWS=6.875*(VDC)-3.75$	$ECWS=3.4375*(mA)-3.75$

If the ECWS input develops an open or short, the LLID will report either a very high or very low value back to the main processor. This will generate an informational diagnostic and the unit will default to using the Front Panel (DynaView) Chilled Water Setpoint.

TechView Service Tool is used to set the input signal type from the factory default of 2-10 VDC to that of 4-20 mA. TechView is also used to install or remove the External Chilled Water Setpoint option as well as a means to enable and disable ECWS.

External Current Limit Setpoint (ECLS) Option

Similar to the above, the CH530 also provides for an optional External Current

Limit Setpoint that will accept either a 2-10 VDC (default) or a 4-20 mA signal.

The Current Limit Setting can also be set via the DynaView or through digital communication with Tracer (Comm 3). The arbitration of the various sources of current limit is described in the flow charts at the end of this section. The External Current Limit Setpoint may be changed from a remote location by hooking up the analog input signal to the 1 U6 LLID terminals 2 and 3. Refer to the following paragraph on Analog Input Signal Wiring Details. The following equations apply for ECLS:

	Voltage Signal	Current Signal
As generated from external source	$VDC+0.133*(\%)-6.0$	$mA=0.266*(\%)-12.0$
As processed by UCM	$\%=7.5*(VDC)+45.0$	$\%=3.75*(mA)+45.0$

Installation Electrical

If the ECLS input develops an open or short, the LLID will report either a very high or very low value back to the man processor. This will generate an informational diagnostic and the unit will default to using the Front Panel (DynaView) Current Limit Setpoint.

The TechView Service Tool must be used to set the input signal type from the factory default of 2-10 VDC to that of 4-20 mA current. TechView must be also be used to install or remove the External Current Limit Setpoint Option for field installation, or can be used to enable or disable the feature (if installed).

ECLS and ECWS Analog Input Signal Wiring Details: Both the ECWS and

ECLS can be connected and setup as either a 2-10 VDC (factory default), 4-20 mA, or resistance input (also a form of 4-20mA) as indicated below. Depending on the type to be used, the TechView Service Tool must be used to configure the LLID and the MP for the proper input type that is being used. This is accomplished by a setting change on the Custom Tab of the Configuration View within TechView.

The J2-3 and J2-6 terminal is chassis grounded and terminal J2- 1 and J2-4 can be used to source 12 VDC. The ECLS uses terminals J2-2 and J2-3. ECWS uses terminals J2-5 and J2-6. Both inputs are only compatible with high-side current sources.

Fig. IV-03 – Wiring Examples for ECLS and ECWS

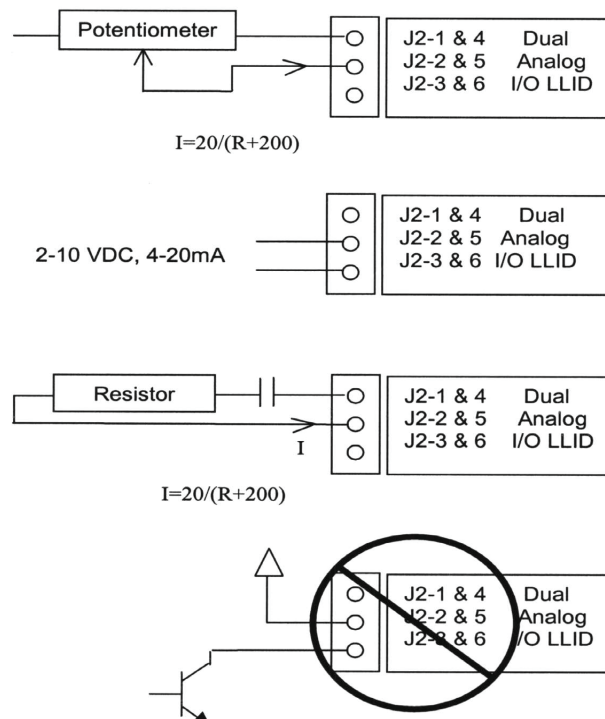

Chilled Water Reset (CWR)

CH530 resets the chilled water temperature set point based on either return water temperature, or outdoor air temperature. Return Reset is standard, Outdoor Reset is optional.

The following shall be selectable:

- One of three Reset Types: None, Return Water Temperature Reset,

Outdoor Air Temperature Reset, or Constant Return Water Temperature Reset.

- Reset Ratio Set Points.

For outdoor air temperature reset there shall be both positive and negative reset ratio's.



Installation Electrical

- Start Reset Set Points.
- Maximum Reset Set Points.

The equations for each type of reset are as follows:

Return

$$CWS' = CWS + \text{RATIO} (\text{START RESET} - (\text{TWE} - \text{TWL}))$$

and $CWS' > \text{or} = CWS$

and $CWS' - CWS < \text{or} = \text{Maximum Reset}$

Outdoor

$$CWS' = CWS + \text{RATIO} * (\text{START RESET} - \text{TOD})$$

and $CWS' > \text{or} = CWS$

and $CWS' - CWS < \text{or} = \text{Maximum Reset}$

where

CWS' is the new chilled water set point or the "reset CWS"

CWS is the active chilled water set point before any reset has occurred, e.g. normally

Front Panel, Tracer, or ECWS

RESET RATIO is a user adjustable gain
START RESET is a user adjustable reference TOD is the outdoor temperature

TWE is entering evap. water temperature

TWL is leaving evap. water temperature

MAXIMUM RESET is a user adjustable limit providing the maximum amount of reset. For all types of reset, $CWS' - CWS < \text{or} = \text{Maximum Reset}$.

Tab. IV-04 – Reset Type

Reset Type	Reset Ratio Range	Start Reset Range	Maximum Range	Increment Reset	Increment SI Units	Factory Default Value
Return:	10 to 120%	4 to 30 F (2.2 to 16.7 C)	0 to 20 F (0.0 to 11.1 C)	1%	1%	50%
Outdoor	80 to -80%	50 to 130 F (10 to 54.4 C)	0 to 20 F (0.0 to 11.1 C)	1%	1%	10%

In addition to Return and Outdoor Reset, the MP provides a menu item for the operator to select a Constant Return Reset. Constant Return Reset will reset the leaving water temperature set point so as to provide a constant entering water temperature. The Constant Return Reset equation is the same as the Return Reset equation except on selection of Constant Return Reset, the MP will automatically set Ratio, Start Reset, and Maximum Reset to the following.

$$\text{RATIO} = 100\%$$

$$\text{START RESET} = \text{Design Delta Temp.}$$

$$\text{MAXIMUM RESET} = \text{Design Delta Temp.}$$

The equation for Constant Return is then as follows:

$$CWS' = CWS + 100\% (\text{Design Delta Temp.} - (\text{TWE} - \text{TWL}))$$

and $CWS' > \text{or} = CWS$

and $CWS' - CWS < \text{or} = \text{Maximum Reset}$

When any type of CWR is enabled, the MP will step the Active CWS toward the desired CWS' (based on the above equations and setup parameters) at a rate of 1 degree F every 5 minutes until the Active CWS equals the desired CWS'. This applies when the chiller is running.

Installation Electrical

When the chiller is not running the CWS is reset immediately (within one minute) for Return Reset and at a rate of 1 degree F every 5 minutes for Outdoor Reset. The chiller will start at the Differential to Start value above a fully reset CWS or CWS' for both Return and Outdoor Reset.

Communications Interface options

Optional Tracer Communications Interface

This option allows the Tracer CH530 controller to exchange information (e.g. operating setpoints and Auto/Standby commands) with a higher-level control device, such as a Tracer Summit or a multiple-machine controller. A shielded, twisted pair connection establishes the bi-directional communications link

between the Tracer CH530 and the building automation system.

To prevent control malfunctions, do not run low voltage wiring (<30 V) in conduit with conductors carrying more than 30 volts.

Field wiring for the communication link must meet the following requirements:

- All wiring must be in accordance with the NEC and local codes.
- Communication link wiring must be shielded, twisted pair wiring (Belden 8760 or equivalent). See the table below for wire size selection:

Tab. IV-05 – Wire Size

Wire Size	Maximum Length of Communication Wire
14 AWG (2.5 mm ²)	5,000 FT (1525 m)
16 AWG (1.5 mm ²)	2,000 FT (610 m)
18 AWG (1.0 mm ²)	1,000 FT (305 m)

- The communication link cannot pass between buildings.
- All units on the communication link can be connected in a “daisy chain” configuration.

LonTalk Communications Interface for Chillers (LCI-C)

CH530 provides an optional LonTalk Communication Interface (LCI-C) between the chiller and a Building Automation System (BAS). An LCI-C LLID shall be used to provide “gateway” functionality between a LonTalk compatible device and the Chiller.

The inputs/outputs include both mandatory and optional network variables as established by the LonMark Functional Chiller Profile 8040.

Installation Recommendations

- 22 AWG Level 4 unshielded communication wire recommended for most LCI-C installations
- LCI-C link limits: 4500 feet, 60 devices

- Termination resistors are required
 - 105 ohms at each end for Level 4 wire
 - 82 ohms at each end for Trane “purple” wire
- LCI-C topology should be daisy chain
- Zone sensor communication stubs limited to 8 per link, 50 feet each (maximum)
- One repeater can be used for an additional 4500 feet, 60 devices, 8 communication stubs

Installation Electrical

El cableado en campo para el link de comunicación debe responder a los siguientes requisitos:

1. Todo el cableado debe estar en conformidad con el NEC y los códigos locales.
2. El cableado del link de comunicación debe ser con un par trenzado blindado (Belden 8760 o equivalente). Ver la siguiente tabla para seleccionar la dimensión de los cables:

Tab. IV-06 Dimensión del cable vs. extensión máxima

Dimensión del cable	Extensión máxima del cable de comunicación
14 AWG (2,5 mm ²)	5000 pies (1525 m)
16 AWG (1,5 mm ²)	2000 pies (610 m)
18 AWG (1,0 mm ²)	1000 pies (305 m)

1. El link de comunicación no puede pasar entre edificaciones.
2. Todas las unidades en el link de comunicación pueden conectarse en una configuración en cascada (daisy chain).

Procedimiento para conexión del link de comunicaciones

1. Consultar la literatura de instalación de Tracer para determinar las conexiones de terminación apropiadas del link de comunicaciones en el panel de Tracer o de Summit.
2. Conectar el blindaje del cableado del link de comunicación al terminal blindado designado en el panel de Tracer o de Summit.
3. Instalar una LLID de interfaz Comm de Tracer en el panel de control del enfriador, si aún no está instalada.
4. Conectar los cables de par torcido a partir del BAS o a partir de la unidad anterior dentro de la configuración en cascada (daisy chain) a los terminales apropiados de la LLID 1U8 de la interfaz Comm3 de Tracer. No hay ninguna exigencia de polaridad para esta conexión.
5. En el CH530, el blindaje debe cortarse o aislarse con cinta para evitar cualquier contacto entre el blindaje y el suelo. Observación: En instalaciones con múltiples unidades, unir el blindaje de dos cables de pares trenzados que se dirigen a cada unidad en el sistema en cascada (daisy chain). Aislar

con cinta las enmiendas de las conexiones para evitar cualquier contacto entre el blindaje y el suelo. En la última unidad de la cadena, la protección debe cortarse o aislarse.

6. Conectar el TechView al controlador de Tracer CH530.
7. Consultar el Configuration View – opción Feature en TechView y verificar si el dígito de “REM – Remote Interface” del número del modelo del enfriador se configuró como “C – Tracer Comm 3 Interface”. Si la opción de interfaz Comm3 de Tracer no está seleccionada, hay que seleccionarla. Consultar también el Configuration View – opción Custom y verificar si la dirección ICS Comm 3 está configurada correctamente. Esta selección solo aparecerá bajo la opción Custom en el Configuration View si el LLID de la interfaz Comm 3 está instalada. Seleccionar luego el botón de configuración de la carga (load configuration) en la parte inferior de la pantalla. Observación: El mensaje Binding View se presentará automáticamente luego de seleccionar “load configurations” si existe algún elemento pendiente para resolver en la comunicación de los dispositivos.
8. Ir a Unit View en TechView y seleccionar el botón “Auto-Remote”. Esto dará prioridad de *setpoint* al BAS que esté conectado a la unidad.



Installation Electrical

Tab. IV-08 Unit electrical data for standard efficiency at all ambient operation

Unit Size	Rated Voltage	# of Power Conns (1)	Unit Wiring				Qty.	Compressor (Each)			Fans (Each)			Control kW (7)
			MCA (3) Ckt1/Ckt2	Max. fuse HACR Breaker or MOP(11) Ckt1/Ckt2	Rec. Time rec. delay or RDE(4) Ckt1/Ckt2	RLA (5) Ckt1/Ckt2		XLRA (8) Ckt1/Ckt2	YLRA (8) Ckt1/Ckt2	Qty. Ckt1/Ckt2	kW	FLA		
RTAC 140	230/60/3	1	581	800	700	2	235-235	NA	427-427	8	0.75	4.6	0.83	
	380/60/3	1	348	450	400	2	142-142	801-801	260-260	8	0.75	2.7	0.83	
	440/60/3	1	288	400	350	2	118-118	652-652	212-212	8	0.75	2.2	0.83	
RTAC 155	230/60/3	1	641	800	800	2	278-235	NA	506-571	9	0.75	4.6	0.83	
	380/60/3	1	380	500	450	2	168-142	973-801	316-260	9	0.75	2.7	0.83	
	440/60/3	1	317	450	400	2	139-118	774-652	252-212	9	0.75	2.2	0.83	
RTAC 170	230/60/3	1	691	800	800	2	278-278	NA	506-506	10	0.75	4.6	0.83	
	380/60/3	1	413	500	500	2	168-168	973-973	316-316	10	0.75	2.7	0.83	
	440/60/3	1	341	450	400	2	139-139	774-774	252-252	10	0.75	2.2	0.83	
RTAC 185	230/60/3	1	770	1000	1000	2	336-278	NA	571-506	11	0.75	4.6	0.83	
	380/60/3	1	460	600	600	2	203-168	1060-973	345-316	11	0.75	2.7	0.83	
	440/60/3	1	380	500	450	2	168-139	878-774	285-252	11	0.75	2.2	0.83	
RTAC 200	230/60/3	1	834	1000	1000	2	336-336	NA	571-571	12	0.75	4.6	0.83	
	380/60/3	1	499	700	600	2	203-203	1060-1060	345-345	12	0.75	2.7	0.83	
	440/60/3	1	412	500	500	2	168-168	878-878	285-285	12	0.75	2.2	0.83	
RTAC 225	230/60/3	1	920	1200	1200	2	399-336	NA	691-571	13	0.75	4.6	0.83	
	380/60/3	1	551	700	700	2	242-203	1306-1060	424-345	13	0.75	2.7	0.83	
	440/60/3	1	454	600	600	2	200-168	1065-878	346-285	13	0.75	2.2	0.83	
RTAC 250	230/60/3	1	989	1200	1200	2	399-399	NA	691-691	14	0.75	4.6	0.83	
	380/60/3	1	594	800	700	2	242-242	1306-1306	424-424	14	0.75	2.7	0.83	
	440/60/3	1	489	600	600	2	200-200	1065-1065	346-346	14	0.75	2.2	0.83	
RTAC 275	230/60/3	2	681/459	800/700	800/600	3	278-278/336	NA	506-506/571	10/6	0.75	4.6	1.2	
	380/60/3	2	413/275	500/450	500/350	3	168-168/203	973-973/1060	316-316/345	10/6	0.75	2.7	1.2	
	440/60/3	2	341/227	450/350	400/300	3	139-139/168	774-774/878	252-252/285	10/6	0.75	2.2	1.2	
RTAC 300	230/60/3	2	834/459	1000/700	1000/600	3	336-336/336	NA	571-571/571	12/6	0.75	4.6	1.2	
	380/60/3	2	499/275	700/450	600/350	3	203-203/203	1060-1060/1060	345-345/345	12/6	0.75	2.7	1.2	
	440/60/3	2	412/227	500/350	500/300	3	168-168/168	878-878/878	285-285/285	12/6	0.75	2.2	1.2	
RTAC 350	230/60/3	2	989/459	1200/700	1200/600	3	399-399/336	NA	691-691/571	14/6	0.75	4.6	1.2	
	380/60/3	2	594/275	800/450	700/350	3	242-242/203	1306-1306/1060	424-424/345	14/6	0.75	2.7	1.2	
	440/60/3	2	490/227	600/350	600/300	3	200-200/168	1065-1065/973	346-346/285	14/6	0.75	2.2	1.2	

Notes:

- As standard, all units have single point power connection. Optional dual point power connections are available.
- Max Fuse or HACR type breaker = 225 percent of the largest compressor RLA plus 100 percent of the second compressor RLA, plus the sum of the condenser fan FLA per NEC 440-22.
Use FLA per circuit, NOT FLA for the entire unit).
- MCA - Minimum Circuit Ampacity - 125 percent of largest compressor RLA plus 100 percent of the second compressor RLA plus the sum of the condenser fans FLAs per NEC 440-33.
- RECOMMENDED TIME DELAY OR DUAL ELEMENT (RDE) FUSE SIZE: 150 percent of the largest compressor RLA plus 100 percent of the second compressor RLA and the sum of the condenser fan FLAs.
- RLA - Rated Load Amps - rated in accordance with UL Standard 1995.
- Local codes may take precedence.
- Control kW includes operational controls only. Does not include evaporator heaters.
- XLRA - Locked Rotor Amps - based on full winding (x-line) start units. YLRA for wye-delta starters is ~1/3 of LRA of x-line units.

9. VOLTAGE UTILIZATION RANGE:

Rated Voltage	Utilization Range
230/60/3	208-254
380/60/3	342-418
440/60/3	414-506

- A separate 115/60/1, 20 amp or 220/50/1, 15 amp customer provided power connection is needed to power the evaporator heaters (1640 watts).
- If factory circuit breakers are supplied with the chiller, then these values represent Maximum Overcurrent Protection (MOP).
- When recommended option with circuit breaker, we are providing two circuit breakers (one per circuit) for feeding single point and double point.



Installation Electrical

Tab. IV-09 Unit electrical data for high efficiency at standard ambient operation

Unit Size	Rated Voltage	# of Power Conns (1)	Unit Wiring			Qty.	Compressor (Each)			Fans (Each)		Control kW (7)	
			MCA (3) Ckt1/Ckt2	Max. fuse HACR Breaker or MOP(11) Ckt1/Ckt2	Rec. Time rec. delay or RDE(4) Ckt1/Ckt2		RLA (5) Ckt1/Ckt2	XLRA (8) Ckt1/Ckt2	YLRA (8) Ckt1/Ckt2	Qty. Ckt1/Ckt2	kW		FLA
RTAC 140	230/60/3	1	572	700	700	2	225-225	NA	427-427	10	0,75	4,6	0,83
	380/60/3	1	341	450	400	2	136-136	801-801	260-260	10	0,75	2,7	0,83
	440/60/3	1	282	350	350	2	113-113	652-652	212-212	10	0,75	2,2	0,83
RTAC 155	230/60/3	1	628	800	700	2	265-225	NA	506-427	11	0,75	4,6	0,83
	380/60/3	1	376	500	416	2	161-136	973-801	316-260	11	0,75	2,7	0,83
	440/60/3	1	310	400	350	2	133-113	774-652	252-212	11	0,75	2,2	0,83
RTAC 170	230/60/3	1	675	800	800	2	265-265	NA	506-506	12	0,75	4,6	0,83
	380/60/3	1	404	500	450	2	161-161	973-973	316-316	12	0,75	2,7	0,83
	440/60/3	1	333	450	400	2	133-133	774-774	252-252	12	0,75	2,2	0,83
RTAC 185	230/60/3	1	755	1000	1000	2	324-265	NA	571-506	13	0,75	4,6	0,83
	380/60/3	1	452	600	500	2	196-161	1060-973	345-316	13	0,75	2,7	0,83
	440/60/3	1	372	500	450	2	162-133	878-774	285-252	13	0,75	2,2	0,83
RTAC 200	230/60/3	1	820	1000	1000	2	324-324	NA	571-571	14	0,75	4,6	0,83
	380/60/3	1	490	600	600	2	196-196	1060-1060	345-345	14	0,75	2,7	0,83
	440/60/3	1	404	500	450	2	162-162	878-878	285-285	14	0,75	2,2	0,83
RTAC 225	230/60/3	1	900	1200	1000	2	388-224	NA	691-571	14	0,75	4,6	0,83
	380/60/3	1	539	700	600	2	235-196	1306-1060	424-345	14	0,75	2,7	0,83
	440/60/3	1	444	600	500	2	194-162	1065-878	346-285	14	0,75	2,2	0,83
RTAC 250	230/60/3	1	977	1200	1200	2	388-388	NA	691-691	16	0,75	4,6	0,83
	380/60/3	1	585	800	700	2	235-235	1306-1306	424-424	16	0,75	2,7	0,83
	440/60/3	1	482	600	600	2	194-194	1065-1065	346-346	16	0,75	2,2	0,83
RTAC 275	230/60/3	2	675/444	800/700	800/600	3	265-265/324	NA	506-506/571	12/6	0,75	4,6	1,2
	380/60/3	2	405/266	500/450	450/350	3	161-161/196	973-973/1060	316-316/345	12/6	0,75	2,7	1,2
	440/60/3	2	333/220	450/350	400/300	3	133-133/162	774-774/878	252-252/285	12/6	0,75	2,2	1,2
RTAC 300	230/60/3	2	820/444	1000/700	1000/600	3	324-324/324	NA	571-571/571	14/6	0,75	4,6	1,2
	380/60/3	2	490/266	600/450	600/350	3	196-196/196	1060-1060/1060	345-345/345	14/6	0,75	2,7	1,2
	440/60/3	2	404/220	500/350	450/300	3	162-162/162	878-878/878	285-285/285	14/6	0,75	2,2	1,2

Notes:

- As standard, all units have single point power connection. Optional dual point power connections are available.
- Max Fuse or HACR type breaker = 225 percent of the largest compressor RLA plus 100 percent of the second compressor RLA, plus the sum of the condenser fan FLA per NEC 440-22.
Use FLA per circuit, NOT FLA for the entire unit).
- MCA - Minimum Circuit Ampacity - 125 percent of largest compressor RLA plus 100 percent of the second compressor RLA plus the sum of the condenser fans FLAs per NEC 440-33.
- RECOMMENDED TIME DELAY OR DUAL ELEMENT (RDE) FUSE SIZE: 150 percent of the largest compressor RLA plus 100 percent of the second compressor RLA and the sum of the condenser fan FLAs.
- RLA - Rated Load Amps - rated in accordance with UL Standard 1995.
- Local codes may take precedence.
- Control kW includes operational controls only. Does not include evaporator heaters.
- XLRA - Locked Rotor Amps - based on full winding (x-line) start units. YLRA for wye-delta starters is ~1/3 of LRA of x-line units.
- VOLTAGE UTILIZATION RANGE:

Rated Voltage	Utilization Range
230/60/3	208-254
380/60/3	342-418
440/60/3	414-506

- A separate 115/60/1, 20 amp or 220/50/1, 15 amp customer provided power connection is needed to power the evaporator heaters (1640 watts).
- If factory circuit breakers are supplied with the chiller, then these values represent Maximum Overcurrent Protection (MOP).
- When recommended option with circuit breaker, we are providing two circuit breakers (one per circuit) for feeding single point and double point.

Installation Electrical

Fig. IV-04 – Arbitration flowcharts of chilled water configuration (Auto Local)

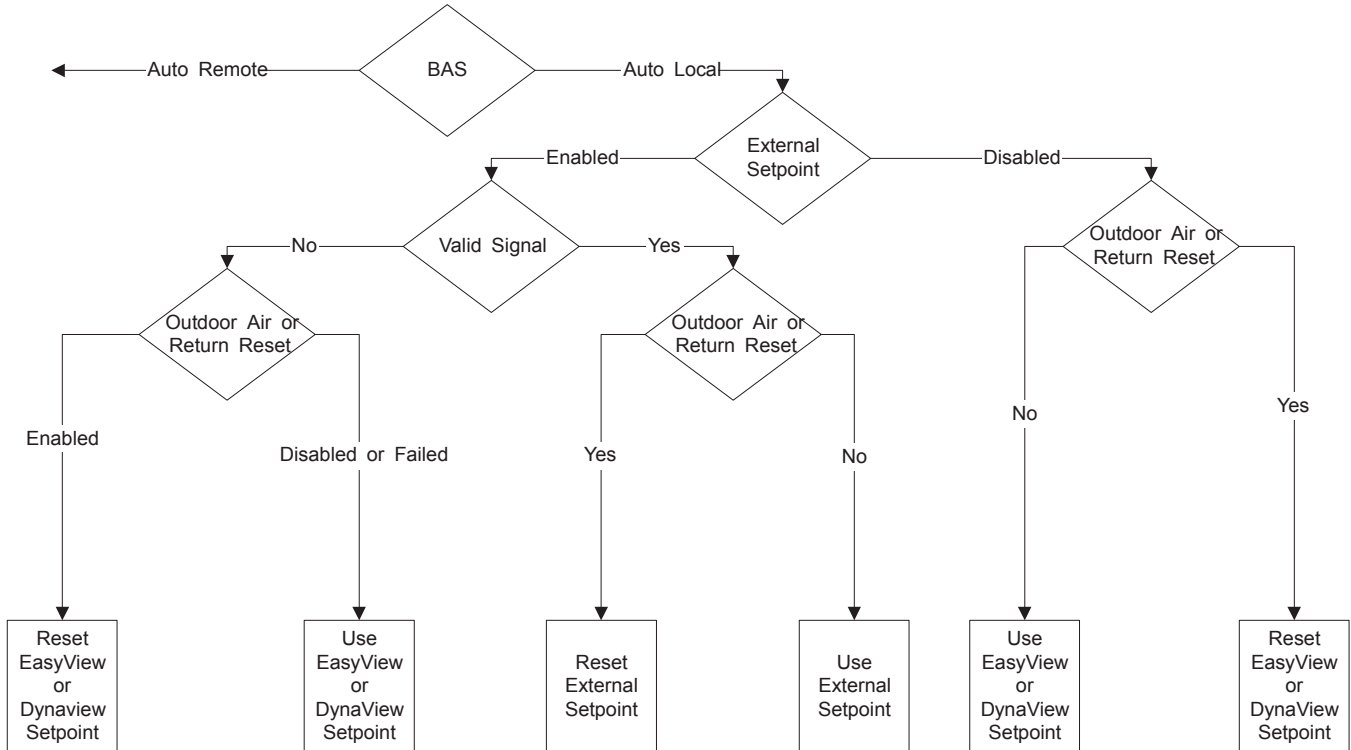

Installation Electrical

Fig. IV-05 – Arbitration flowcharts of chilled water configuration (Auto remote)

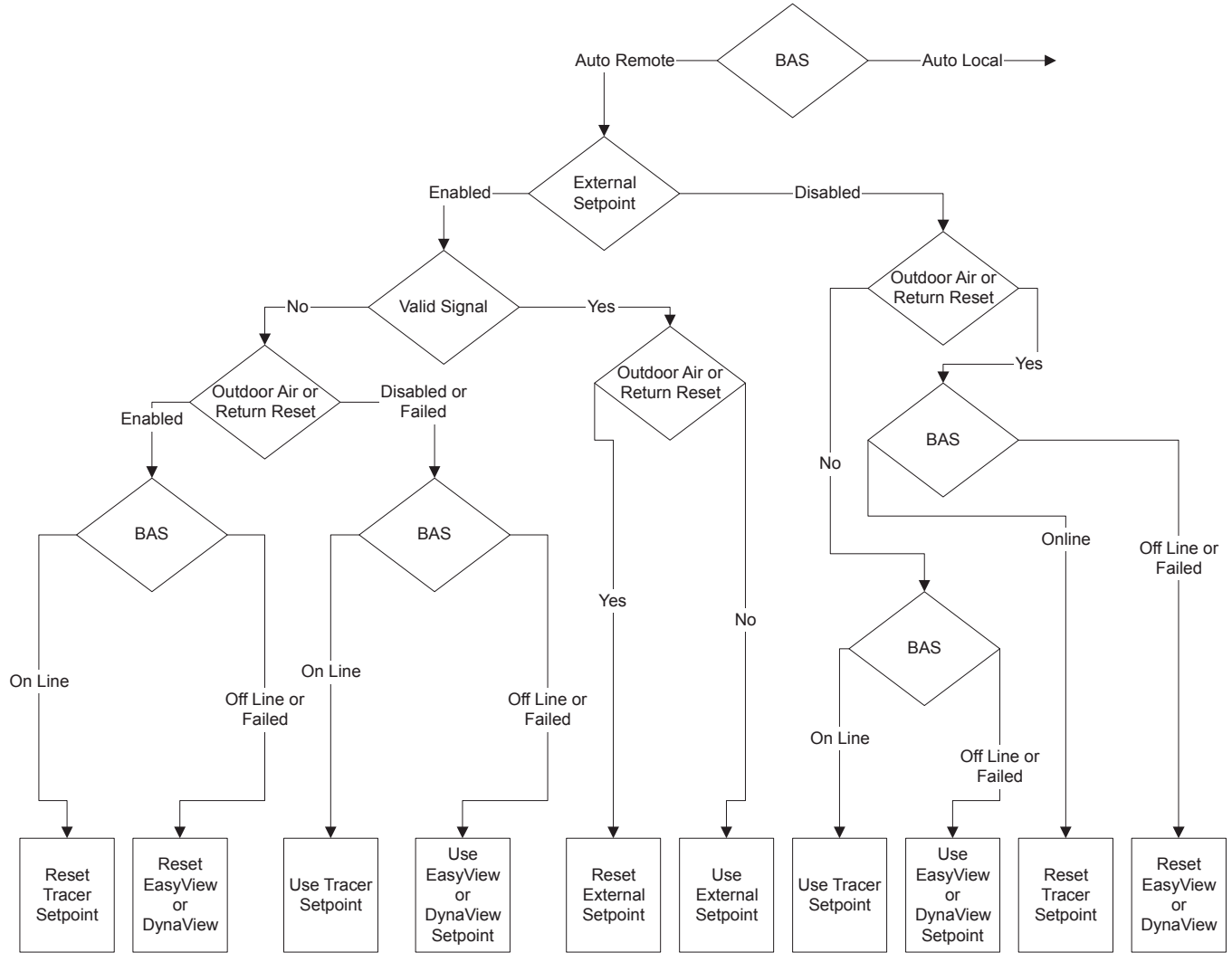

Note: If Tracer(Auto-Remote) and External Setpoint co-exist, the last source enabled will control the resultant setpoint. The chart above assumes External Setpoint is enabled (or disabled) subsequent to Tracer Auto-Remote setting.

Installation Electrical

Fig. IV-06 – Arbitration flowcharts of Current limit setting

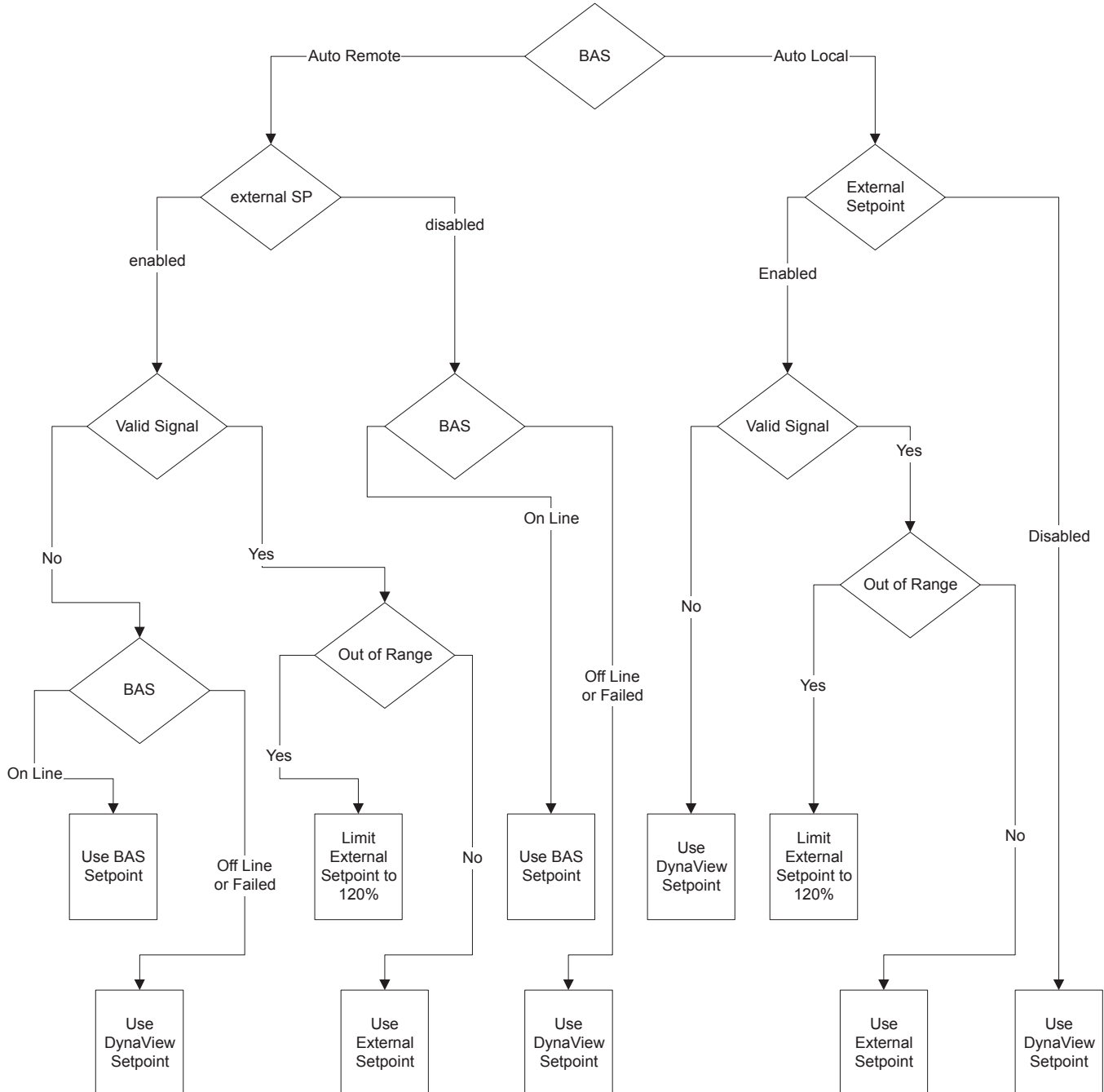

Installation Electrical

Fig. IV-07 – Arbitration flowcharts of configuration points Auto/Stop External

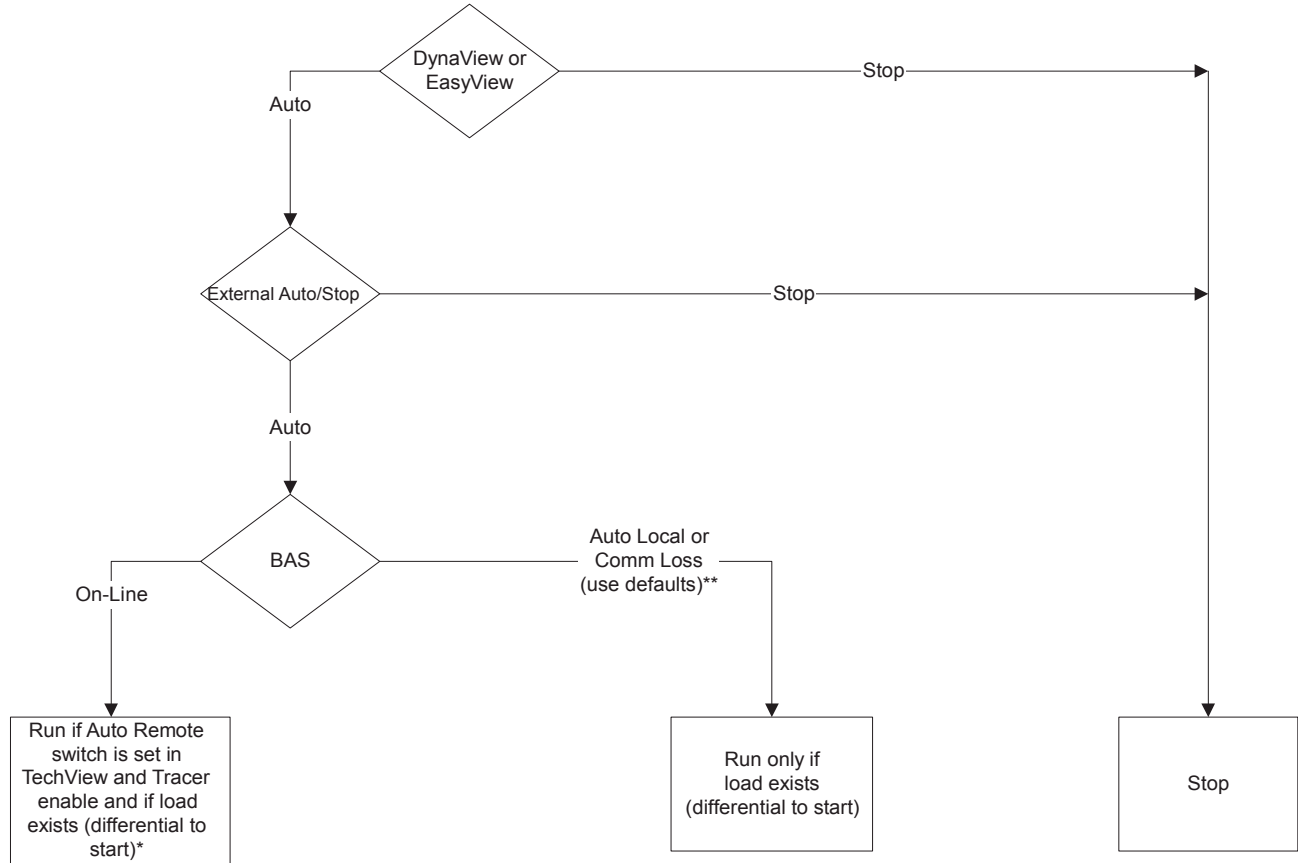

Notes:

*Mode transition from disable to enable shall start unit if LWT>CWS regardless of differential to start. Subsequent starts during Tracer enable will include differential to start criteria.

**if Tracer communication is lost for 15 minutes, the auto/off mode will be determined by a user defined configuration parameter to allow

- 1) last sent mode
- 2) off
- 3) auto

Installation Electrical

Fig. IV-08 – Arbitration flowcharts of configuration points of locking circuit

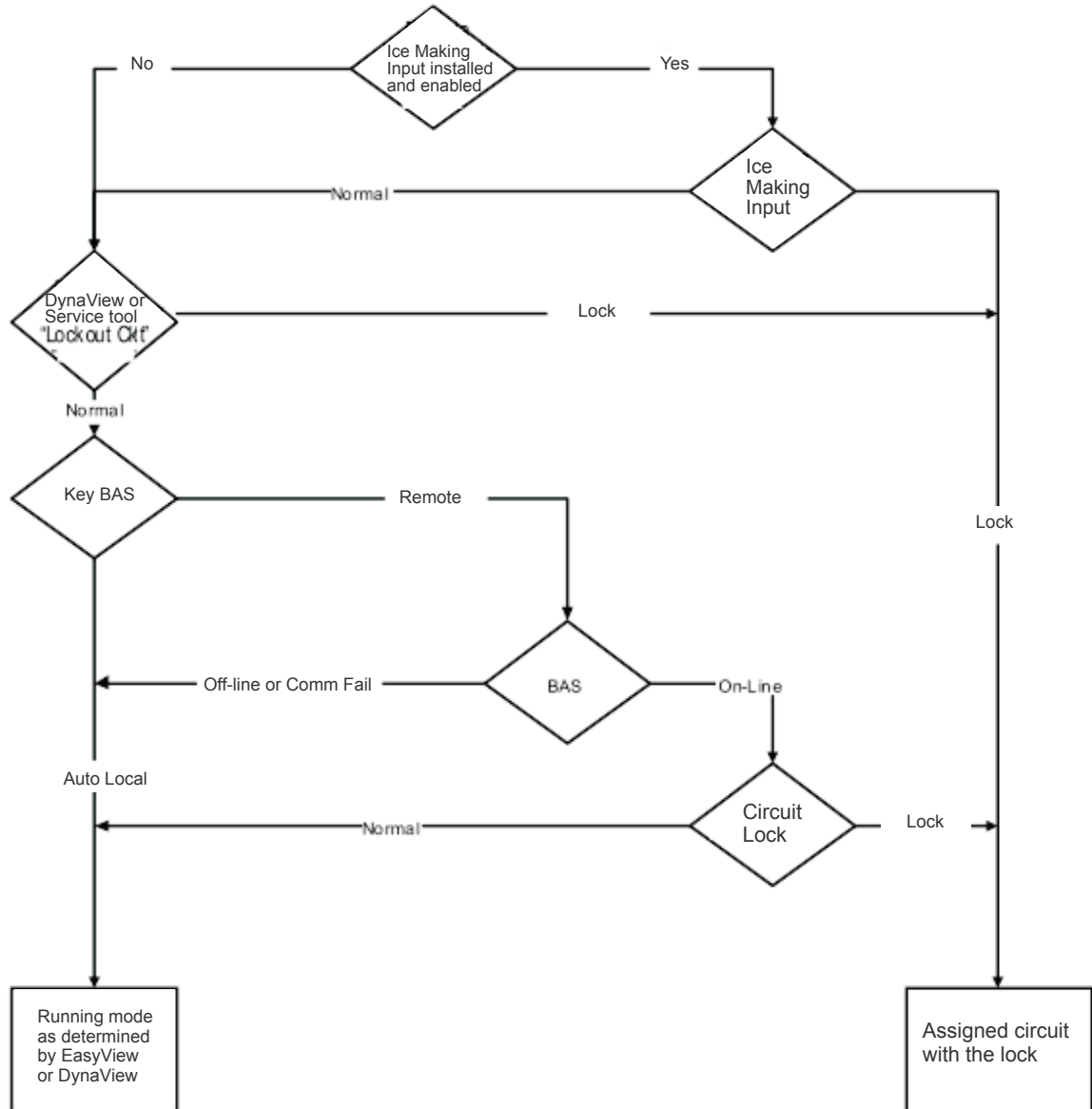

If the lockout is imposed by circuit service tool, the lock should remain in effect until removed by the tool, even without connection to service tool. For example, a technician can initiate a lock from the service tool, disconnect the service tool and keep the lock.

Installation Electrical

Fig. IV-09 – Arbitration flowcharts of Control of Ice manufacturing

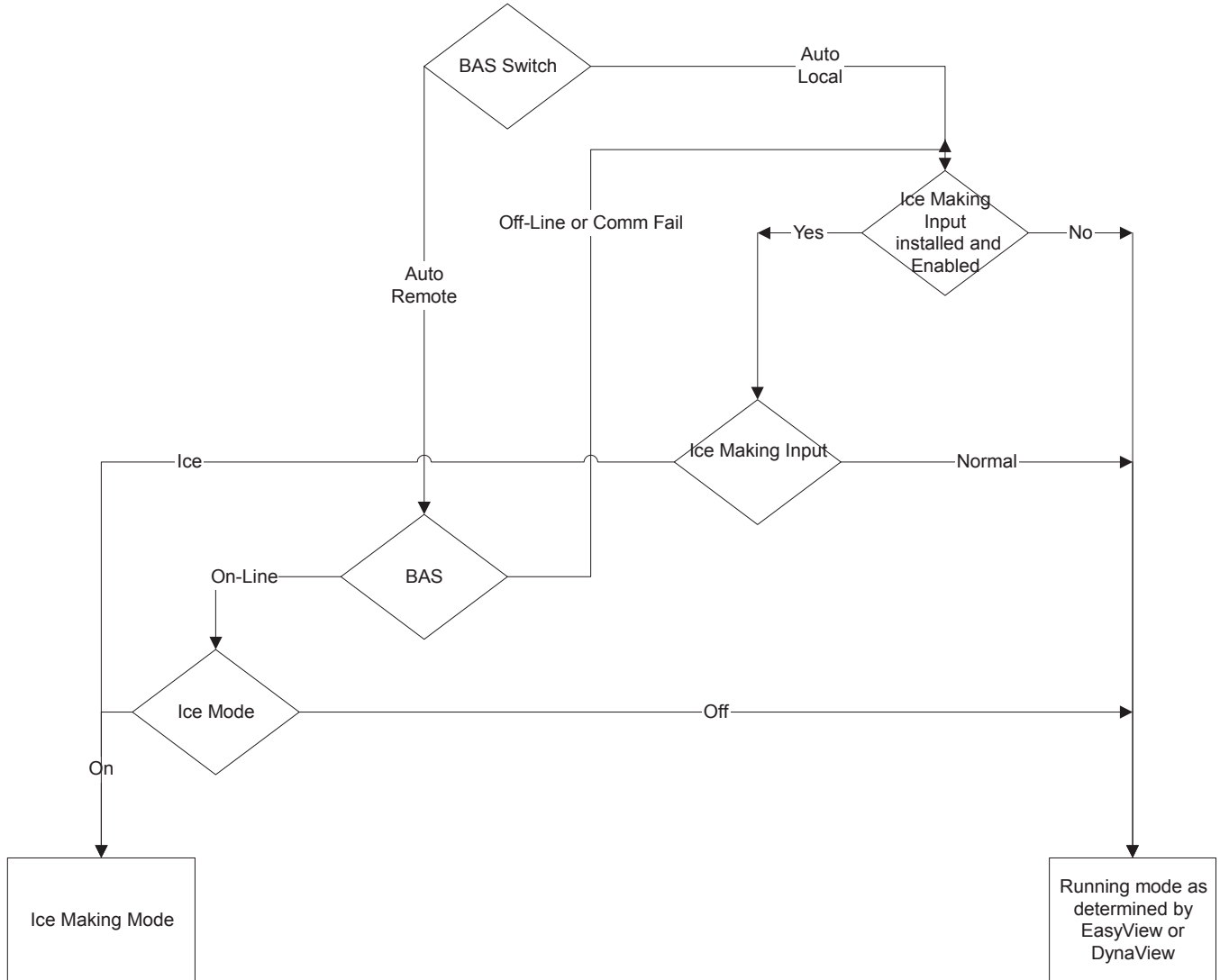

V-Operating Principles

Tab. V-01 – LonTalk Points List

LonTalk Communications Interface

Inputs	Variable type		SNVT_Type
Chiller Enable/Disable	binary	start(1)/stop(0)	SNVT_switch
Chilled Water Setpoint	analog	temperature	SNVT_temp_p
Current Limit Setpoint	analog	% current	SNVT_lev_percent
Chiller Mode	Note 1		SNVT_hvac_mode
Outputs	Variable type		SNVT_Type
Outputs	Variable type		SNVT_Type
Chiller On/Off	binary	on(1)/off(0)	SNVT_switch
Active Chilled Water Setpoint	analog	temperature	SNVT_temp_p
Percent RLA	analog	% current	SNVT_lev_percent
Active Current Limit Setpoint	analog	% current	SNVT_lev_percent
Leaving Chilled Water Temperature	analog	temperature	SNVT_temp_p
Entering Chilled Water Temperature	analog	temperature	SNVT_temp_p
Entering Condenser Water Temperature	analog	temperature	SNVT_temp_p
Leaving Condenser Water Temperature	analog	temperature	SNVT_temp_p
Alarm Description	Note 2		SNVT_str_asc
Chiller Status	Note 3		SNVT_chlr_status

Note 1: Chiller Mode is used to place the chiller into an alternate mode; Cool or Ice Build

Note 2: Alarm Description denotes alarm severity and target. Severity: no alarm, warning, normal shutdown, immediate shutdown Target: Chiller, Platform, Ice Building (Chiller is refrigerant circuit and Platform is control circuit)

Note 3: Chiller Status describes Chiller Run Mode and Chiller Operating Mode. Run Modes: Off, Starting, Running, Shutting Down Operating Modes: Cool, Ice Build States: Alarm, Run Enabled, Local Control, Limited, CHW Flow, Cond Flow

Operating Principles

This section contains an overview of the operation and maintenance of RTAC units equipped with CH530 control systems. It describes the overall operating principles of the RTAC design.

Refrigeration Cycle

The refrigeration cycle of the RTAC chiller is similar to that of the RTAA air cooled water chiller. The exception is that the evaporating and condensing temperatures have been increased to allow for optimization of the chiller and

reduced foot print. The refrigeration cycle is represented in the pressure enthalpy diagram in Figure 33. Key state points are indicated on the figure. The cycle for the full load ARI design point is represented in the plot.

Fig. V-01 – Pressure Enthalpy (P-h) diagram of RTAC chiller circuit

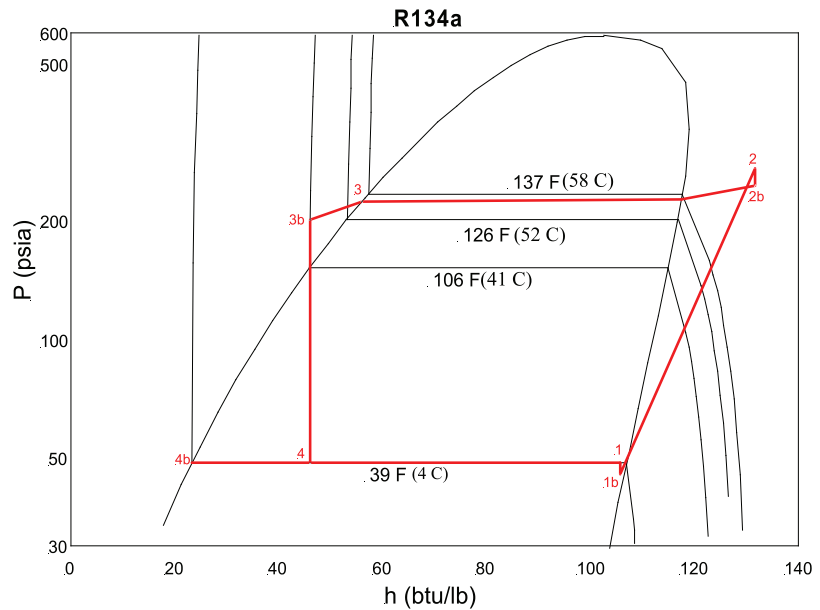

The RTAC chiller uses a shell and tube evaporator design with refrigerant evaporating on the shell side and water flowing inside tubes having enhanced surfaces (states 4 to 1). The suction lines and bolt pads are designed to minimize pressure drop (states 1 to 1b). The compressor is a twin-rotor helical rotary compressor designed similarly to the compressors offered in other Trane Screw Compressor Based Chillers (states 1b to 2).

The discharge lines include a highly efficient oil separation system that virtually removes all oil from the refrigerant stream going to the heat exchangers (states 2 to 2b). De-superheating, condensing and sub-cooling is accomplished in a fin and tube air cooled heat exchanger where refrigerant is condensed in the tube (states 2b to 3b). Refrigerant flow through the system is balanced by an electronic expansion valve (states 3b to 4).

Operating Principles

Fig. V-02 – System Schematic

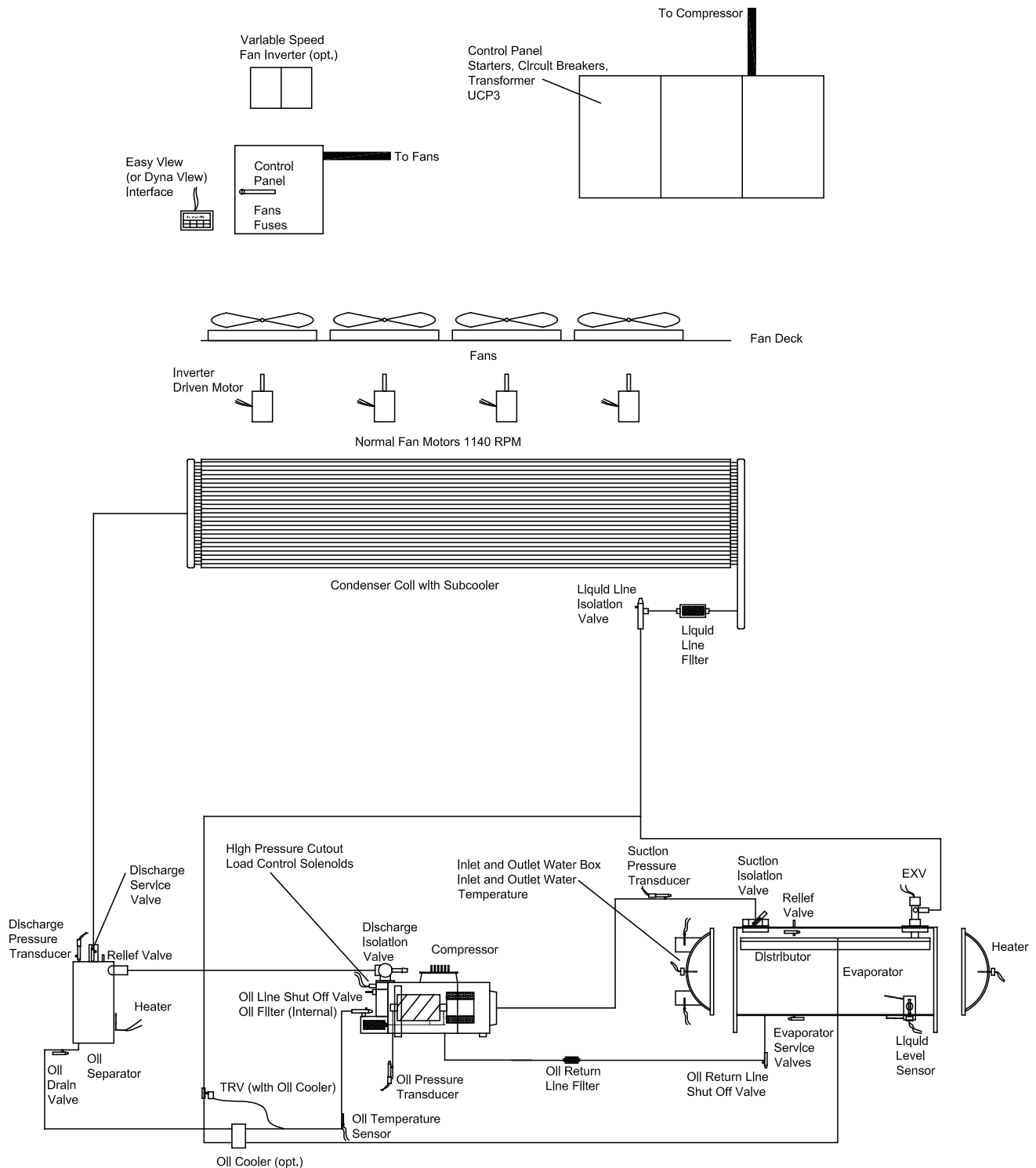



Operating Principles

Refrigerant R134a

The RTAC chiller uses environmentally friendly R134a. Trane believes that responsible refrigerant practices are important to the environment, our customers, and the air conditioning industry. All technicians who handle refrigerants must be certified. The Federal Clean Air Act (Section 608) sets forth the requirements for handling, reclaiming, recovering and recycling of certain refrigerants and the equipment that is used in these service procedures. In addition, some states or municipalities may have additional requirements that must also be adhered to for responsible management of refrigerants. Know the applicable laws and follow them.

R134a is a medium pressure refrigerant. It may not be used in any condition that could cause the chiller to operate in a vacuum without a purge system. RTAC is not equipped with a purge system. Therefore, the RTAC chiller may not be operated in a condition that would result in a saturated condition in the chiller of -15°F (-26°C) or lower.

R134a requires the use of specific POE oils as designated on the unit nameplate.

Important! The RTAC units must only operate with R-134a and Trane Oil 00048.

Compressor

The compressor is a semi-hermetic, direct-drive rotary type compressor. Each compressor has only four moving parts: two rotors that provide compression and male and female load-control valves. The male rotor is attached to the motor and the female rotor is driven by the male rotor. The rotors and motor are supported by bearings.

The helical rotary compressor is a positive displacement device.

Refrigerant vapor from the evaporator is drawn into the suction opening of the compressor (state 1b), through a suction strainer screen across the motor (which provides motor cooling) and into the intake of the compressor rotors.

The gas is then compressed and discharged through a check valve and

into the discharge line (state 2).

There is no physical contact between the rotors and the compressor housing. The rotors contact each other at the point where the driving action between the male and female rotors occurs. Oil is injected into the rotors of the compressor, coating the rotors and the compressor housing interior. Although this oil does provide rotor lubrication, its primary purpose is to seal the clearance spaces between the rotors and compressor housing. A positive seal between these internal parts enhances compressor efficiency by limiting leakage between the high pressure and low pressure cavities.

Capacity control is accomplished by means of a female step load-control valve and a male control valve. The female step valve is the first stage of loading after the compressor starts and the last stage of unloading before the compressor shuts down. The male control valve is positioned by a piston cylinder along the length of the male rotor. Compressor capacity is dictated by the position of the loading valve relative to the rotors. When the valve slides toward the discharge end of the rotors compressor capacity is reduced.

Condenser and Subcooler

The condenser and subcooler are similar to the condenser used in RTAA chillers. The heat exchanger consists of 3/8" tubes that contain the refrigerant, large fins that are in the air flow and fans that draw air through the fins. Heat is transferred from the refrigerant through the tubes and fins to the air.

High pressure gas from the compressor enters the tubes of the condenser through a distribution header (state 2b). As refrigerant flows through the tubes, the heat of compression and cooling load are rejected to the air. In this process the refrigerant is desuperheated, condensed (states 2b to 3) and finally subcooled (states 3 to 3b) to a temperature slightly above the ambient air temperature. The subcooled liquid refrigerant is collected in the leaving header where it is transferred to the liquid line (state 3b).

A controls algorithm always runs as many fans as possible without reducing the differential pressure (discharge minus suction) below the setpoint (60 psid or 4.2 bar). If a warm enough ambient is sensed, all the fans will run. If the ambient is cooler, some fans are shut off to maintain the pressure differential. Fan staging depends on the chiller load, evaporator pressure, condenser effectiveness, ambient temperature, and numbers and sizes of fans installed on the circuit.

The algorithm pre-starts fans (based on ambient and water temperatures) when a circuit starts the compressor. (For rare conditions such as during some pull-downs, a steady fan state would either violate the 60 psid (4.2 bar) setpoint or cause a high pressure cut-out; in those conditions a fan will cycle on and off.)

For up to two minutes after chiller start-up, the setpoint is 35 psi (2.45 bar) difference, and then before the controls adjust gradually over half a minute up to 60 psi (4.2 bar).

Expansion Valve

Pressure drop occurs in an electronic expansion valve. The unit controller (CH530) uses the valve to regulate the flow through the liquid line to match the flow produced by the compressor. The valve has a variable orifice that is modulated by a stepper motor.

High pressure, subcooled liquid refrigerant enters the expansion valve from the liquid line. As refrigerant passes through the valve the pressure is dropped substantially, which results in vaporization of some of the refrigerant. The heat of vaporization is supplied by the two phase mixture resulting in low temperature low pressure refrigerant which is supplied to the evaporator (state 4) to provide cooling.

Operating Principles

Evaporator

The evaporator is composed of a liquid-vapor distributor and falling film evaporator.

A liquid-vapor refrigerant mixture enters the distributor (state 4). The mixture is distributed over the length of the evaporator tubes (state 4b). Liquid is evenly distributed over the length of the evaporator tubes by the two-phase distribution system. A portion of the liquid boils as it falls by gravity from tube to tube, wetting all the tubes of the evaporator. To ensure that the tubes at the bottom of the evaporator do not experience "dry out," a liquid pool is maintained in the bottom few inches of the bundle. Tubes located in the bottom of the evaporator will evaporate the liquid refrigerant by boiling (pool boiling).

Heat is transferred from the water or glycol inside the tubes to the liquid refrigerant as the film of refrigerant evaporates on the surface of the tube. Thin film heat transfer requires a smaller temperature difference for a given amount of heat transfer than nucleate boiling, which is the heat transfer process used in flooded evaporators. Hence, efficiency is enhanced by the use of falling film evaporation. Additionally, the evaporator requires less refrigerant than a comparable flooded evaporator and the evaporator boils the entire refrigerant supply at constant pressure. Refrigerant vapor exits the evaporator through the suction line (state 1).

Oil System

Screw compressors require large quantities of oil for lubricating and sealing the rotors and lubricating the bearings. This oil is mixed with refrigerant at the discharge of the compressor. To enhance the performance of the heat exchanger surfaces an oil separation system is placed into the discharge line. The oil separator is located between the compressor and the condenser. It separates oil using highly efficient centrifugal force. Approximately 99.5% of the oil is removed from the refrigerant in the separator.

Oil that is removed from the refrigerant falls by gravity into the oil sump. This oil is directed back to the compressor through the oil lines. Internal to the compressor is a high efficiency filter to clean the oil before it is delivered to the rotors and bearings. Once oil is injected into the compressor rotors it mixes with the refrigerant again and is delivered back to the discharge line.

Operating Principles

Oil that gets past the oil separators flows through the condenser, subcooler and expansion valve into the evaporator. This oil is collected in the pool of refrigerant that is maintained in the bottom of the evaporator. A small amount of oil and refrigerant from this pool (state 4b) is returned through a line that is connected to the compressor down stream of the motor. This oil and refrigerant mixes with the refrigerant vapor that was drawn out of the evaporator, prior to injection into the compressor rotors.

Fig. V-03 – RTAC Oil System

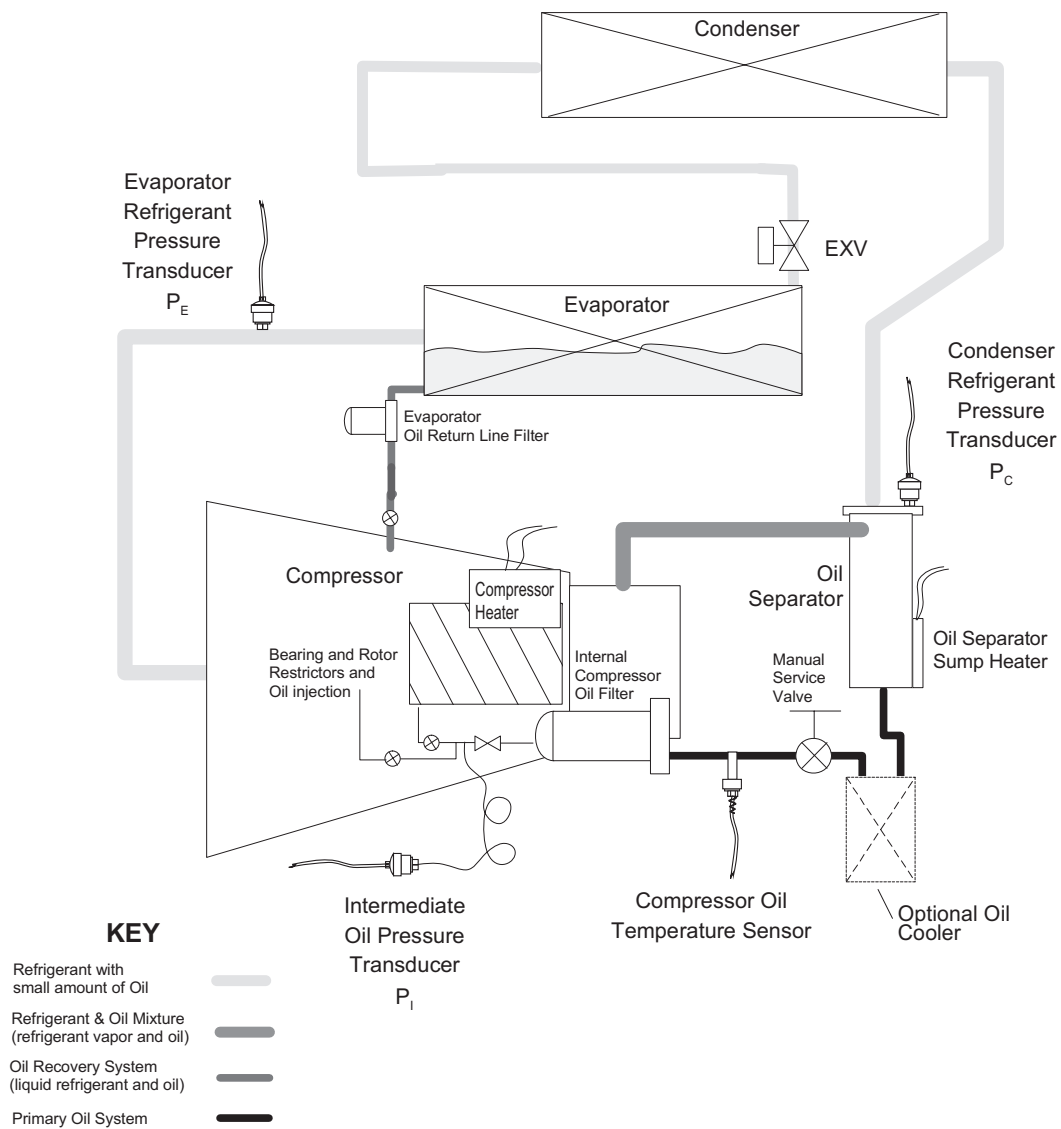



VI-Controls Interface

CH530 Communications Overview

The Trane CH530 control system that runs the chiller consists of several elements:

- The main processor collects data, status, and diagnostic information and communicates commands to the starter module and the LLID (for Low Level Intelligent Device) bus. The main processor has an integral display (DynaView).
- Higher level modules (e.g. starter) exist only as necessary to support system level control and communications. The starter module provides control of the starter when starting, running, and stopping the chiller motor. It also processes its own diagnostics and provides motor and compressor protection.
- Low level intelligent device (LLID) bus. The main processor communicates to each input and output device (e.g. temperature and pressure sensors, low voltage binary inputs, analog input/output) all connected to a four-wire bus, rather than the conventional control architecture of signal wires for each device.
- The communication interface to a building automation system (BAS).
- A service tool to provide all service/maintenance capabilities.

Main processor and service tool (TechView) software is downloadable from www.Trane.com. The process is discussed later in this section under TechView Interface.

DynaView provides bus management. It has the task of restarting the link, or filling in for what it sees as “missing” devices when normal communications has been degraded. Use of TechView may be required.

The CH530 uses the IPC3 protocol based on RS485 signal technology and communicating at 19.2 Kbaud to allow 3 rounds of data per second on a 64-device network. A typical four compressor RTAC will have around 50 devices.

Most diagnostics are handled by the DynaView. If a temperature or pressure is reported out of range by a LLID, the DynaView processes this information and calls out the diagnostic. The individual LLIDs are not responsible for any diagnostic functions. The only exception to this is the Starter module.

NOTE: It is imperative that the CH530 Service Tool (TechView) be used to facilitate the replacement of any LLID or reconfigure any chiller component. TechView is discussed later in this section.

Controls Interface

Each chiller is equipped with a DynaView interface. The DynaView has the capability to display information to the operator including the ability to adjust settings. Multiple screens are available and text is presented in multiple languages as factory-ordered or can be easily downloaded from www.trane.com.

TechView can be connected to either the DynaView module and provides further data, adjustment capabilities, diagnostics information using downloadable software.

DynaView Interface

The DynaView share the same enclosure design: weatherproof and durable plastic for use as a stand-alone device on the outside of the unit or mounted nearby.

The display on DynaView is a 1/4 VGA display with a resistive touch screen and an LED backlight. The display area is approximately 4 inches wide by 3 inches high (102mm x 60mm).

Controls Interface

Fig. VI-01 DynaView



Key Functions

In this touch screen application, key functions are determined completely by software and change depending upon the subject matter currently being displayed. The basic touch screen functions are outlined below.

Radio Buttons

Radio buttons show one menu choice among two or more alternatives, all visible. (It is the AUTO button in Figure 36.) The radio button model mimics the buttons used on old-fashioned radios to select stations. When one is pressed, the one that was previously pressed “pops out” and the new station is selected. In the DynaView odel

the possible selections are each associated with a button. The selected button is darkened, presented in reverse video to indicate it is the selected choice. The full ange of possible choices as well as the current choice is always in view.

Spin Value Buttons

Spin values are used to allow a variable setpoint to be changed, such as leaving water setpoint. The value increases or decreases by touching the increment (+) or decrement (-) arrows.

Action Buttons

Action buttons appear temporarily and provide the user with a choice such as Enter or Cancel.

Hot Links

Hot links are used to navigate from one view to another view.

File Folder Tabs

File folder tabs are used to select a screen of data. Just like tabs in a file folder, these serve to title the folder/screen selected, as well as provide navigation to other screens. In DynaView, the tabs are in one row across the top of the display. The folder tabs are separated from the rest of the display by a horizontal line. Vertical lines separate the tabs from each other. The folder that is selected has no horizontal line under

Controls Interface

Its tab, thereby making it look like a part of the current folder (as would an open folder in a file cabinet). The user selects a screen of information by touching the appropriate tab.

Display Screens Basic Screen Format

The basic screen format appears as:

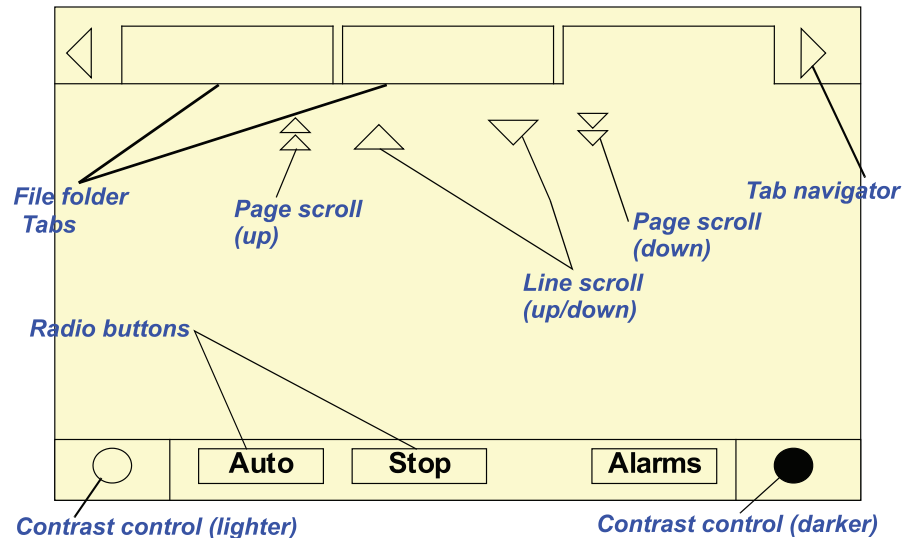

The file folder tabs across the top of the screen are used to select the various display screens.

Scroll arrows are added if more file tabs (choices) are available. When the tabs are at the left most position, the left navigator will not show and only navigation to the right will be possible. Likewise when the right most screen is selected, only left navigation will be possible.

The main body of the screen is used for description text, data, setpoints, or keys (touch sensitive areas). The Chiller Mode is displayed here.

The double up arrows cause a page-by-page scroll either up or down. The single arrow causes a line by line scroll to occur. At the end of the page, the appropriate scroll bar will disappear.

A double arrow pointing to the right indicates more information is available about the specific item on that same line. Pressing it will bring you to a subscreen that will present the information or allow changes to settings.

The bottom of the screen (Fixed

Display) is present in all screens and contains the following functions. The left circular area is used to reduce the contrast/ viewing angle of the display. The right circular area is used to increase the contrast/viewing angle of the display. The contrast may require re-adjustment at ambient temperatures significantly different from those present at last adjustment.

The other functions are critical to machine operation. The AUTO and STOP keys are used to enable or disable the chiller. The key selected is in black (reverse video). The chiller will stop when the STOP key is touched and after completing the Run Unload mode.

Touching the AUTO key will enable the chiller for active cooling if no diagnostic is present. (A separate action must be taken to clear active diagnostics.)

The AUTO and STOP keys, take precedence over the Enter and Cancel keys. (While a setting is being changed, AUTO and STOP keys are recognized even if Enter or Cancel has not been pressed

Controls Interface

The ALARMS button appears only when an alarm is present, and blinks (by alternating between normal and reverse video) to draw attention to a diagnostic condition. Pressing the ALARMS button takes you to the corresponding tab for additional information.

Front Panel Lockout Feature

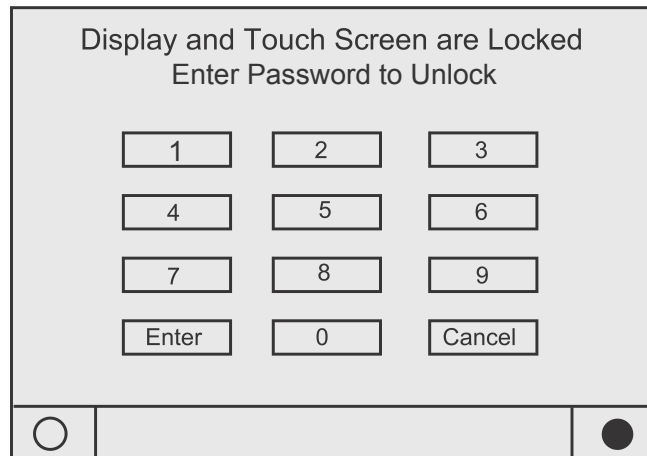

NOTE: The DynaView display and Touch Screen Lock screen is shown below. This screen is used if the Display and touch screen and lock feature is enabled. Thirty minutes after the last keystroke, this screen is displayed and the Display and Touch Screen is locked out until the sequence "159 <ENTER>" is pressed.

Until the proper password is entered, there will be no access to the DynaView screens including all reports, setpoints, and Auto/Stop/Alarms/Interlocks.

The password "159" is not programmable from either DynaView or TechView.

Modes Screen

The Mode Screen is only found on software revisions 18 and later. This screen provides a display for the top level operating mode for each of the components and sub-components of the chiller (i.e. Chiller, Circuits, and Compressors) that exist on the Chiller as it is configured. The modes are displayed as text only without the hex codes.

In software revisions 17.0 and earlier, the top level mode and the sub mode for each component was displayed on the respective component tab on the first two lines. The mode display of the first three lines of the Compressor and Chiller Screen tabs is eliminated with the addition of the Mode Screen

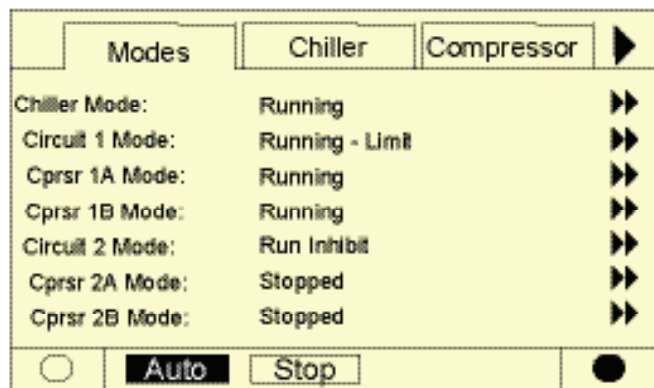

Controls Interface

Chiller Screen

The chiller screen is a summary of the chiller activity.

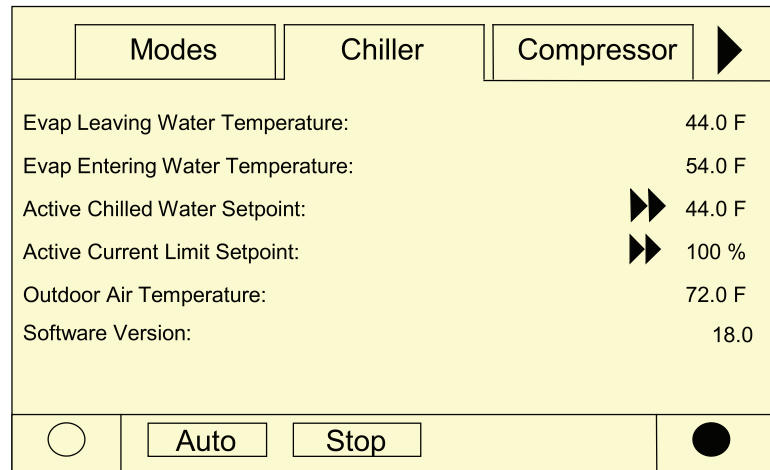

Tab. VI-01 - Chiller Screen

Description	Resolution	Units
Evap Leaving Water Temperature	X.X	F / C
Evap Entering Water Temperature	X.X	F / C
Active Chilled Water Setpoint	X.X	F / C
Active Current Limit Setpoint	X	% RLA
Out Door Temperature	X.X	F / C
Software Type	RTA	Text
Software Version	X.XX	Text

Compressor Screen

The compressor screen displays information for the one, two, three, or four compressors in the format shown. The top line of radio buttons allows you to select the compressor of interest. The next three lines show the compressor operating mode. The compressor radio buttons and the compressor operating mode lines don't change as you scroll down in the menu.

The top screen has no upward scroll keys. The single arrow down scrolls the screen one line at a time. As soon as the display is one line away from the top, the upward pointing arrow appears.

The last screen has a single arrow to scroll upward one line at a time. When in the last position, the single down arrow disappears.

Controls Interface

Each compressor has its own screen depending on which radio key is pressed. When toggling between compressor screens, say to compare starts and run time, the same lines can be seen without additional key strokes. For example, toggling from the bottom of the compressor 1A menu accesses the top of the compressor 2A menu.

Modes		Chiller		Compressor		▶
▼	1A	1B	2A	2B		
Amps L1 L2 L3:			55.0	56.2	54.3	
% RLA:			86.0	88.4	84.3	
Unit Volts:			460			
Oil Temperature:			95.0		F	
Intermediate Oil Pressure:			102.9		psig	
Suction Pressure:			32.6		psig	
○	Auto	Stop				●

Tab. VI-02 - Compressor Screen

Description	Resolution	Units
Amps L1 L2 L3	XXX	Amps
% RLA L1 L2 L3	X.X	% RLA
Unit Volts	XXX	Volts
Oil Temperature	X.X	F / C
Intermediate Oil Pressure	X.X	Pressure
Suction Pressure	X.X	Pressure
Starts/ Run Hours	X, XX:XX	hr:min

Refrigerant Screen

The refrigerant screen displays those aspects of the chiller related to the refrigerant circuits.

◀	Chiller	Compressor	Rfgt.	▶
			<u>Ckt 1</u>	<u>Ckt 2</u>
Cond Rfgt Pressure:			185.0	185.0 psig
Sat Cond Rfgt Temp:			125.0	125.0 F
Evap Rfgt Pressure:			30.0	30.0 psig
Sat Evap Rfgt Temp:			34.0	34.0 F
Evap Approach Temp:			4.0	4.0 F
Rfgt Liquid Level:			0.1	-0.1 in
○	Auto	Stop		
			●	

Controls Interface

Tab. VI-03 - Refrigerant Screen

Description	Resolution	Units
Cond Rfgt Pressure Ckt1/Ckt2	X.X	Pressure
Sat Cond Rfgt Temp Ckt1/Ckt2	X.X	F / C
Evap Rfgt Pressure Ckt1/Ckt2	X.X	Pressure
Sat Evap Rfgt Temp Ckt1/Ckt2	X.X	F / C
Evap Approach Temp Ckt1/Ckt2	X.X	F / C
Rfgt Liquid Level Ckt1/Ckt2	X.X	Height

Setpoint Screen

The setpoint screen is a two-part screen. Screen 1 lists all setpoints available to change along with their current value. The operator selects a setpoint to change by touching either the verbal description or setpoint value. Doing this causes the screen to switch to Screen 2.

In Screen 1 the language setpoint will always be the last setpoint in the list. This will facilitate language changes by placing that control in a standard

position across all CH.530 product lines.

Screen 2 displays the current value of the chosen setpoint in the upper ½ of the display. It is displayed in a changeable format consistent with its type. Binary setpoints are considered to be simple two state enumeration and will use radio buttons. Analog setpoints are displayed as spin buttons. The lower half of the screen is reserved for help screens.

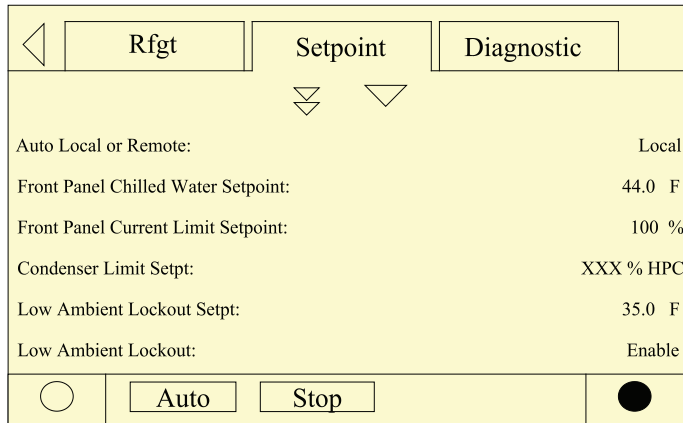

Tab. VI-04 - Setpoint Screen

Description	Resolution or Text	Units
Auto Local or Remote	Remote/Local	Text
Front Panel Chilled Water Setpoint	X.X	F / C
Front Panel Current Limit Setpoint	XXX	% RLA
Differential to Start	X.X	Temperature
Differential to Stop	X.X	Temperature
Condenser Limit Setpoint	Enable/Disable	Text
Low Ambient Lockout Setpoint	X.X	Temperature
Low Ambient Lockout	Enable/Disable	Text
Ice Build	Enable/Disable	Text
Front Panel Ice Termination Setpoint	X.X	Temperature

Controls Interface

Tab. VI-05 - Setpoint Screen

Description	Resolution or Text	Units
Comp 1A Pumpdown	Pumpdown/Abort	Text
Comp 1B Pumpdown	Pumpdown/Abort	Text
Comp 2A Pumpdown	Pumpdown/Abort	Text
Comp 2B Pumpdown	Pumpdown/Abort	Text
EXV Ckt 1 Open	Auto/Open	Text
EXV Ckt 2 Open	Auto/Open	Text
Front Panel Ckt 1 Lockout	Locked Out/Not Locked Out	Text
Front Panel Ckt 2 Lockout	Locked Out/Not Locked Out	Text
Ext Chilled Water Setpoint	X.X	F / C
Ext Current Limit Setpoint	XXX	% RLA
Date Format	mmm dd yyyy, dd mm yyyy	Text
Date		Text
Time Format	12 hr, 24 hr	Text
Time of Day		Text
Keypad/Display Lockout	Enable/Disable	Text
Display Units	SI, English	Text
Pressure Units	Absolute, Gauge	Text
Language Selection	Downloaded from TechView	Text

Tab. VI-06 - Setpoint Screen

Description	Resolution or Text	Units
Ice Building	Enable/Disable	If feature is installed, operation can be initiated or stopped
Cprsr Pumpdown ¹	Avail	Pumpdown is allowed: only with unit in Stop or when circuit is locked out
	Not Avail	Pumpdown is not allowed because unit is operating or pumpdown has
	Pumpdown	State is displayed while pumpdown is in progress
EXV Ckt Open circuit is locked out (For Authorized Service Use ²)	Avail	Indicates EXV is closed but can be opened manually since unit is in Stop or
	Not Avail	EXV is closed but cannot be opened manually since unit is operating
open,	Open	State is displayed when EXV is open. Unit will not start with EXV manually set, but will initiate valve closure first.
Ckt Lockout	Locked Out	Circuit is locked out at Front Panel; other circuit may be available to run
	Not Locked Out	Circuit is not locked out and is available to run
Ext. Chilled Water Setpt	Enable/Disable	Allows unit to control setpoint; otherwise another loop controller in line will control, as optionally wired.
Ext. Current Limit Setpt	Enable/Disable	Allows unit to control setpoint; otherwise another loop controller in line will, as optionally wired.

Notes:

¹ Pumpdown procedure are discussed in Maintenance section 10.

² Used for liquid level control or to recover from pumpdown

Diagnostic Screen

The diagnostic screen (shown following) is accessible by either pressing the blinking ALARMS key or by pressing the Diagnostic tab on the screen tab selection.

A hex code and a verbal description appears on the display as shown typically above. This is the last active diagnostic. Pressing the “Reset All Active Diagnostics” will reset all active diagnostics regardless of type, machine or refrigerant circuit. Compressor diagnostics, which hold off only one compressor, are treated as circuit diagnostics,



Controls Interface

consistent with the circuit to which they belong. One circuit not operating will not shut the chiller down. Viewing the “Compressor” screen will indicate whether a circuit is not operating and for what reason.

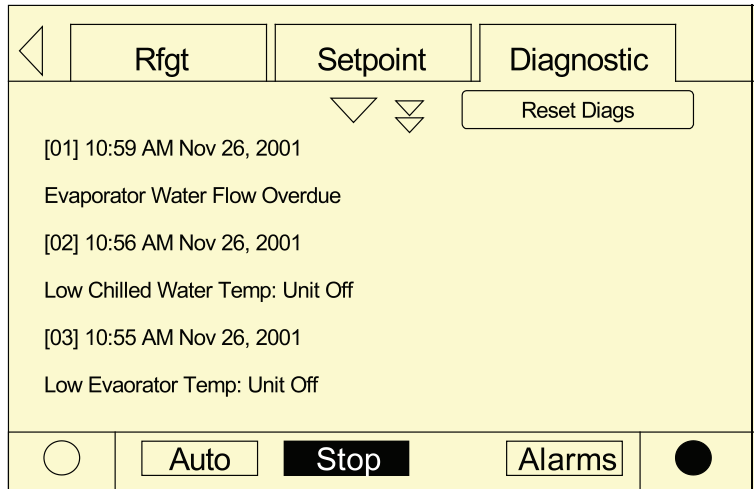

A complete listing of diagnostics and codes is included in the Diagnostic Section.

Power-Up

On Power-Up, DynaView will progress through three screens:

First Screen, Version # of the Boot, full version # displayed.

This screen will display for 5 seconds and move on to the second screen. The contrast will also be adjustable from this screen.

Second Screen, Application or No Application.

This screen will display for 5 seconds “A Valid Application Is Present” or “A Valid Application Is Not Present” and move on to the third screen.

Third Screen, First screen of the Application, the Chiller Tab.

Display Formats

Units

Temperature settings are in °F or °C, depending on Display Units settings. Settings can be entered in tenths or whole degrees depending on a menu setting at the Tech-View.

Dashes (“—”) appearing in a temperature or pressure report, indicates that the value is invalid or not applicable.



Languages

English plus two alternate languages may be installed with DynaView and will reside in the main processor. English will always be available. Alternate languages must be installed using TechView, Software Download View.

Controls Interface

Active Chilled Water Subscreen

The active chilled water setpoint is that setpoint to which the unit is currently controlling. It is determined by the front panel, Tracer, or external setpoints, which in turn may be subject to a form of chilled water reset.

 Back		
Active Chilled Water Setpoint Arbitration		
Front Panel	44.0 F	Active
BAS	----	
External	42.0 F	Active
Chilled Water Reset		Return / Constant Return / Outdoor / None
Active Chilled Water Setpoint		44.0 F
	Auto	Stop 

The chilled water reset status area in the right most column will display one of the following messages

- Return
- Constant Return
- Outdoor
- None

The left column text “Front Panel”, “BAS”, “External”, and “Active Chilled Water Setpoint” will always be present. In the second column, “_ _ _ _” will be shown if that option is not installed.

Pressing the “Back” button takes you back to the chiller screen.

Active Current Limit Setpoint

The active current limit setpoint is the setpoint that is currently in use, displayed in % RLA. Touching the double arrow to the left of the Active Current Limit Setpoint will change the display to the active current limit setpoint subscreen.

Controls Interface

Active Current Limit Subscreen

The active current limit setpoint is that setpoint to which the unit is currently controlling, based on the front panel, Tracer, or external setpoints.

◀ Back			
Active Current Limit Setpoint Arbitration			
Front Panel	100 %		
BAS	----		
External	70 %	Active	
Active Current Limit Setpoint			100 %
<input type="radio"/>	<input type="button" value="Auto"/>	<input type="button" value="Stop"/>	<input checked="" type="radio"/>

The left column text “Front Panel”, “BAS”, “External”, and “Active Current Limit Setpoint” will always be present. In the second column, “_ _ _ _” will be shown if that option is not installed.

Active Ice Termination Subscreen

◀ Back			
Active Ice Termination Setpoint Arbitration			
Front Panel	31.0 F	Active	
BAS	----		
Active Ice Termination Setpoint			31.0 F
<input type="radio"/>	<input checked="" type="button" value="Auto"/>	<input type="button" value="Stop"/>	<input checked="" type="radio"/>

The “Back” button provides navigation back to the chiller screen.

Controls Interface

Refrigerant Screen

The refrigerant screen displays those aspects of the chiller related to the refrigerant circuits.

All pressures are displayed to 0.1 psig or 1 kPa.

Chiller		Compressor		Rfgt.		▶
				Ckt 1	Ckt 2	
Cond Rfgt Pressure:		185.0	185.0	psig		
Sat Cond Rfgt Temp:		125.0	125.0	F		
Evap Rfgt Pressure:		30.0	30.0	psig		
Sat Evap Rfgt Temp:		34.0	34.0	F		
Evap Approach Temp:		4.0	4.0	F		
Refrigerant Liquid Level		0.1	-0.1	in		
<input type="radio"/>	Auto	Stop				<input checked="" type="radio"/>

Condenser Refrigerant Pressure Circuit 1 and 2

DynaView always displays all pressures (English or SI) as gauge pressures. The correct setting of the local atmospheric pressure is necessary for accurate gauge display.

Condenser Refrigerant Temperature Circuit 1 and 2

The main processor will calculate and display a saturated temperature based on the respective pressure read.

Evaporator Refrigerant Pressure Circuit 1 and 2

DynaView always displays all pressures (English or SI) as gauge pressures. The correct setting of the local atmospheric pressure is necessary for accurate gauge display.

Evaporator Refrigerant Temperature Circuit 1 and 2

The main processor will calculate and display a saturated temperature based on the respective pressure read.

Evaporator Approach Temperature Circuit 1 and 2

The approach temperature is calculated from the leaving water temperature minus the saturated evaporator temperature for the respective circuit.

Refrigerant Liquid Level Circuit 1 and 2 (only available on software revisions 18.0 or later)

Controls Interface

The refrigerant liquid level is displayed relative to the optimum liquid level control point inside the evaporator shell. The liquid level sensors range is generally between -1.0 to +1.1 inches. If the display reads +1.0 of -1.0 inches, the liquid level may be higher or lower than this, respectively.

Compressor Screen

The compressor screen displays information for the one, two, three, or four compressors in the format shown. The top line of radio buttons allows you to select the compressor of interest.

The next three lines show the compressor operating mode. The compressor radio buttons and the compressor operating mode lines don't change as you scroll down in the menu.



The top screen has no upward scroll keys. The single arrow down scrolls the screen one line at a time. As soon as the display is one line away from the top, the upward pointing arrow appears.

The last screen has a single arrow to scroll upward one line at a time. When in the last position, the single down arrow disappears.

Each compressor has its own screen depending on which radio key is pressed. When toggling between compressor screens, say to compare starts and run time, the same lines can be seen without additional key strokes. For example, toggling from the bottom of the compressor 1A menu accesses the top of the compressor 2A menu.

Compressor Mode

The compressor mode indicates the status of each compressor independent of unit mode.

See Table for a complete listing of compressor modes.

Line Currents

Line currents are displayed in amps to the nearest tenth from 0.0 to 999.9.

%RLA

The line% running load amps will be displayed to the nearest tenth from 0.0 to 999.9.

Line-Line Voltages

The single line-to-line voltage displayed is A-B in unit volts. Note: Only Compressor 1A has a voltage input and display.

Controls Interface

This item displays the suction pressure associated with the given compressor. In certain chillers, without suction isolation valves installed, there will be no suction pressure transducer directly associated with compressors 1B and 2B. In this case, the values will be displayed as N/A (not applicable).

Compressor Starts

Compressor starts are displayed 0 to 999,999.

Compressor Run Hours

Compressor running hours will be rounded to the nearest hour, 0 to 999,999.

Setpoint Screen

The setpoint screen is a two-part screen. Screen 1 lists all changeable setpoints along with their current value. You can select a setpoint by touching either the verbal description or setpoint value. Doing this causes the screen to switch to Screen 2.

Screen 2 displays the current value of the chosen setpoint in the upper half of the display in a changeable format depending on the type. Binary setpoints use radio buttons. Analog setpoints are displayed as spin buttons. The lower half of the screen is reserved for help screens.

Analog Setpoint Subscreens

All setpoint subscreens will execute the equivalent of a Cancel key if any action or key is pressed before a new setpoint is entered. All setpoint subscreens will have a 10-minute timeout, which is reset when any key activity occurs. After 10 consecutive minutes of inactivity, the setpoint subscreen will return to the first chiller screen.

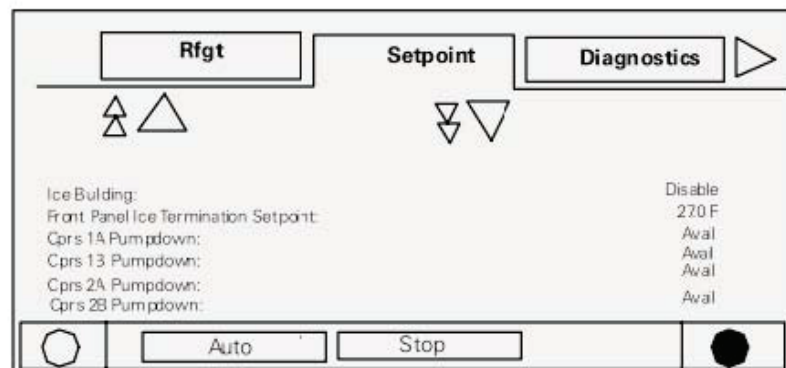
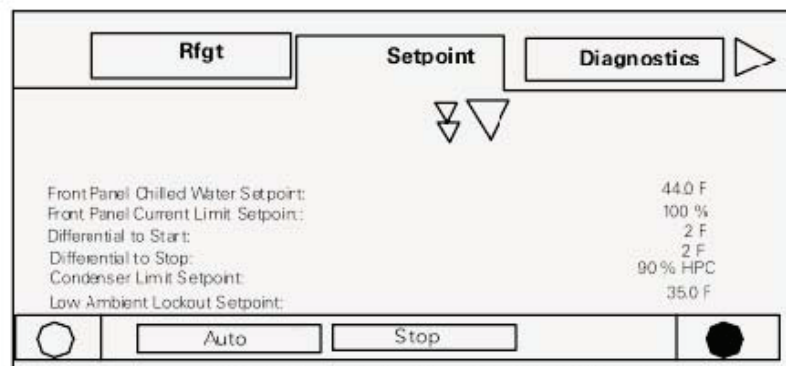

Controls Interface

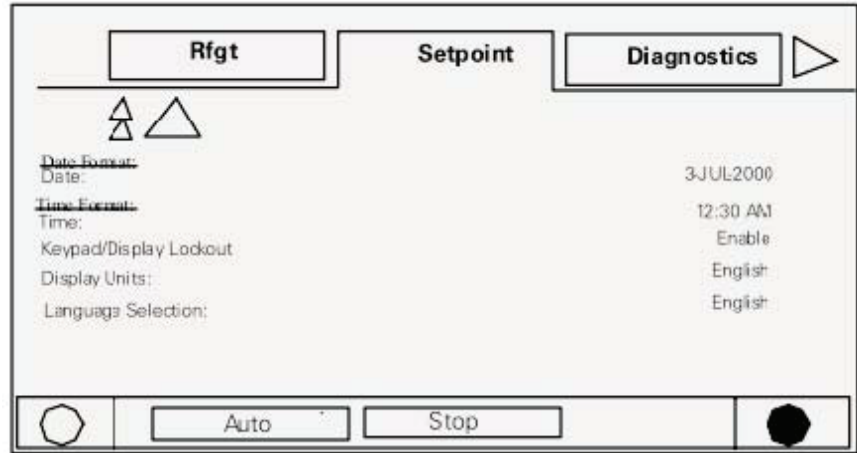

Setpoint List Screen

The following setpoints can be reviewed or changed:

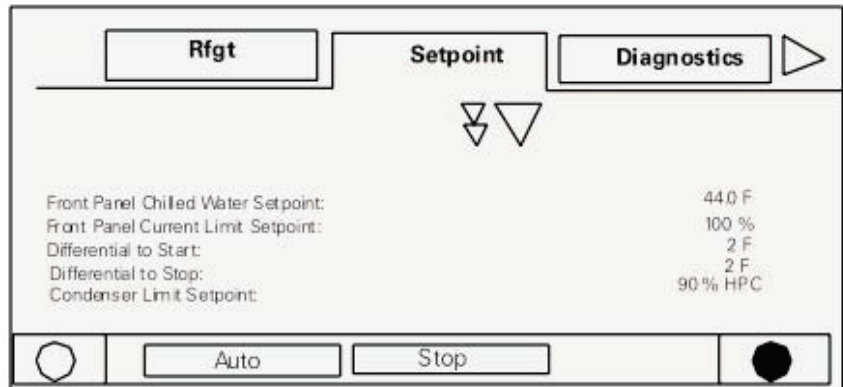

Enumerated Setpoints Subscreen

This subscreen is activated by pressing one of the two radio keys:

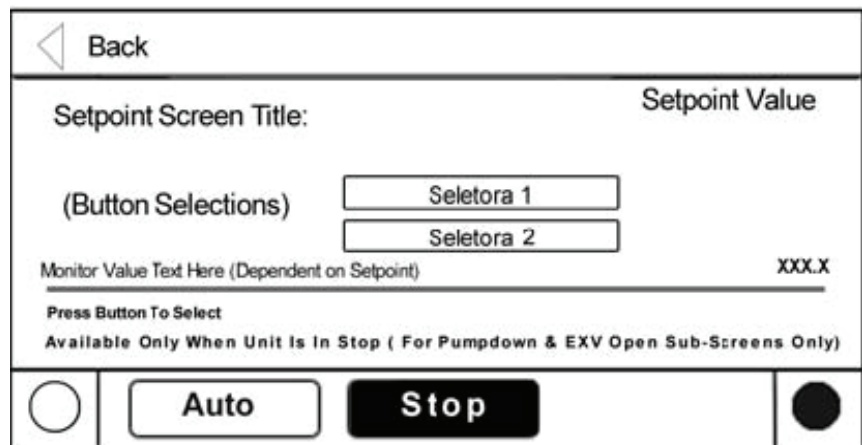

Controls Interface

The remote devices identified on the following setpoint screen are discussed in the Electrical.

Installation section of this manual.

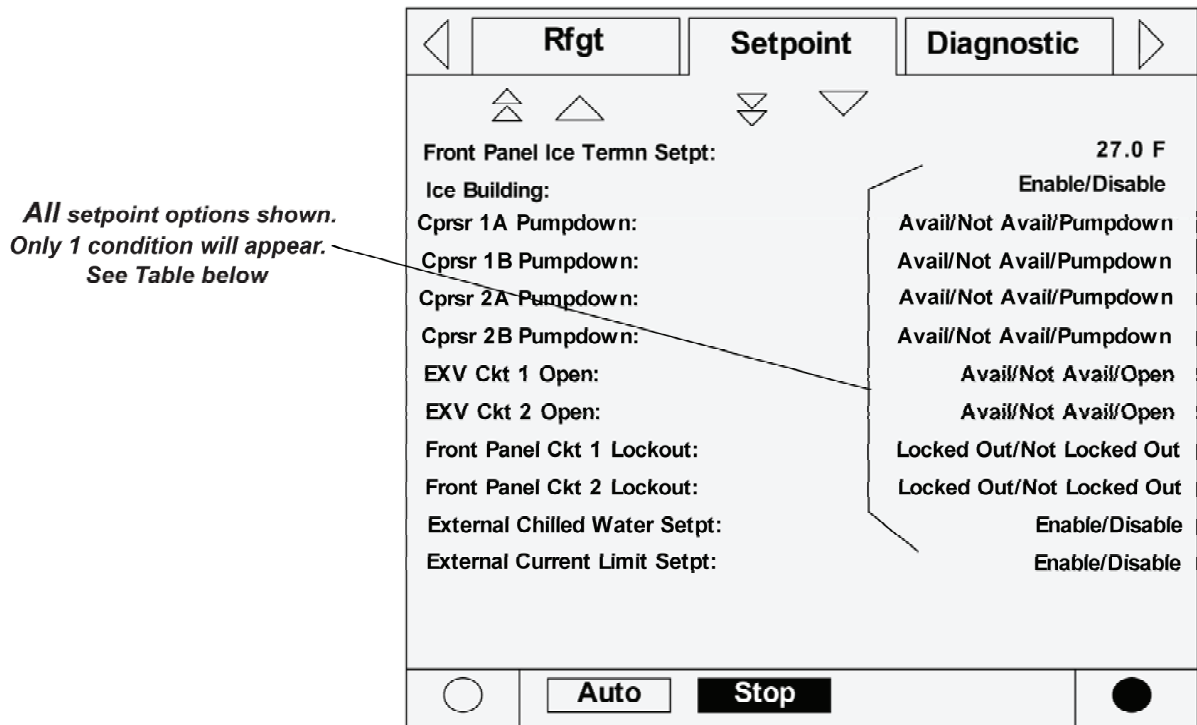

Tab. VI-07 – Setpoint Options/Conditions Displayed

Option	Condition(s)	Explanation
Ice Building	Enable/Disable	If future is installed, operation can be initiated or stopped.
Cprsr Pumpdown ¹	Avail	Pumpdown is allowed: only with unit in Stop or when circuit is locked out.
	Not Avail	Pumpdown is not allowed because unit is operating or pumpdown has been completed.
	Pumpdown	State is displayed while pumpdown is in progress.
EXV Ckt Open (For Authorized Service Use Only ²)	Avail	Indicates EXV is closed but can be opened manually since unit is in Stop or circuit is Lockout
	Not Avail	EXV is closed but cannot be opened manually since unit is operating
	Open	State is displayed when EXV is open. Unit will not start with EXV manually set open, but will initiate valve closure first.
Ckt Lockout	Locked Out	Circuit is locked out at Front Panel, other circuit may be available to run.
	Not Locked Out	Circuit is not locked out and is available to run.
Ext. Chilled Water Setpoint.	Enable/ Disable	Allows unit to control setpoint; otherwise another loop controller in line will control, as optionally wired.
Ext. Chilled Current Limit Setpoint	Enable/ Disable	Allows unit to control setpoint; otherwise another loop controller in line will control, as optionally wired.

Notes:

1 Pumpdown procedure are discussed in Maintenance section 10.

2 Used for liquid level control or to recover from pumpdown.



Controls Interface

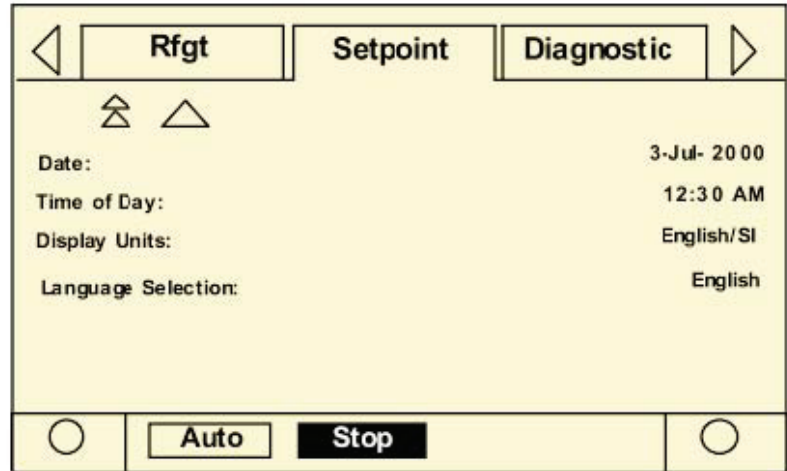

Tab. VI-08 – Setpoint Subscreens – Table of Text, Data, Ranges, etc.

Setpoint Screen Title	Resolution	Setpoint Field	Button Selections		Monitor Value
			Radio 1	Radio 2	
Auto Local or Remote			Remoto	Local	
Front Panel CWS	(3)	+ o - XX.X			
Front Panel CLS	Integer (4)	XXX			
Condenser Limit Stpt	Integer (4)	XXX			
Low Ambient Lockout Stpt	(3)	+ o - XX.X			
Low Ambient Lockout			Enable	Enable	
Ice Building			Disable	Disable	
Front Panel Ice Term. Set pt	(3)	+ o - XX.X			
Cprsr 1A Pumpdown (7)			Vaciar (1)	Abort	Comp 1A Suction Pressure
Cprsr 1B Pumpdown (7)			Vaciar (1)	Abort	Comp 1B Suction Pressure
Cprsr 2A Pumpdown (7)			Vaciar (1)	Abort	Comp 2A Suction Pressure
Cprsr 2B Pumpdown (7)			Vaciar (1)	Abort	Comp 2B Suction Pressure
EXV Ckt 1 Open (7)			Open (1)	Auto	Ckt 1 Evaporator Pressure
EXV Ckt 2 Open (7)			Open (1)	Auto	Ckt 2 Evaporator Pressure
Ckt 1 Lockout			Enable	Disable	
Ckt 2 Lockout			Enable	Disable	
External Chilled Water Setpt			Enable	Disable	
External Current Limit Set point			Enable	Disable	
Date	(6)	(6)			
Time of Day	(6)	(6)			
Display Units			English	SI	
Language			Selection 1 (2)	Selection 2 (2)	

Notes:

- (1) Button is reverse video while the function is active and then returns to normal.
- (2) Language choices are dependent on what the Service Tool has setup in the Main Processor. Get Radio Button names from Main Processor setups.
- (3) Temperatures will be adjustable to 0.1 °F or °C or 1 deg F or C dependent on the resolution setting adjustable through the Service Tool. The Main Processor will provide the minimum and maximum allowable value.
- (4) Adjustable to nearest integer or whole %. The Main Processor will provide the minimum and maximum allowable value.
- (5) Enables a DynaView Lockout screen. All other screens time out in 30 minutes to this screen. The DynaView Lockout Screen will have 0-9 keypad to permit the user to reenter the other DynaView screens with a fixed password.
- (6) The Date and Time setup screen formats deviate slightly from the standard screens defined above. See the alternate screen layouts following.
- (7) The subscreen for these setpoints will have the additional direction "Available OnlyWhen Unit Is In Stop".

Controls Interface

The setpoint screen for setting up the CH530 date is shown below: Select Month, Day, or Year and then use the up/down arrows to adjust.

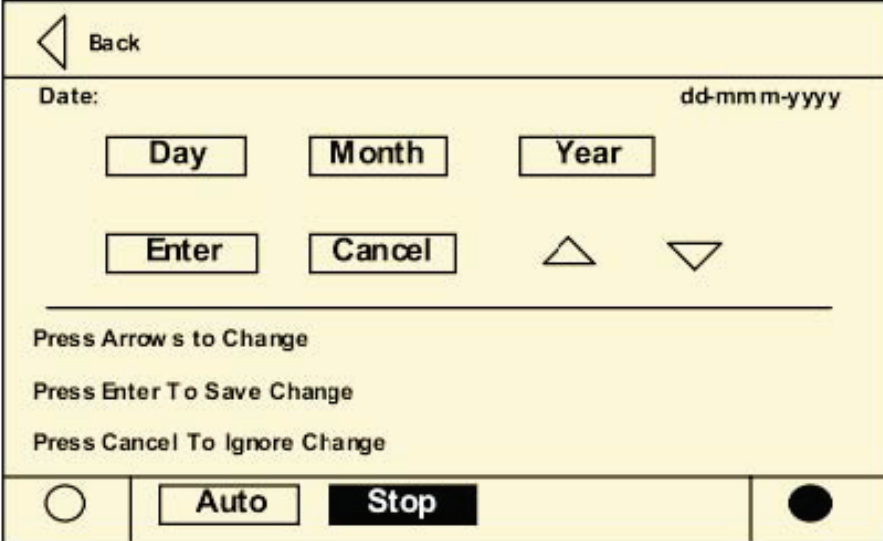

The setpoint screen for setting up the CH530 time with a 12-hour format is shown below: Select Hour, Minute, or AM/PM and then use the up/down arrows to adjust.

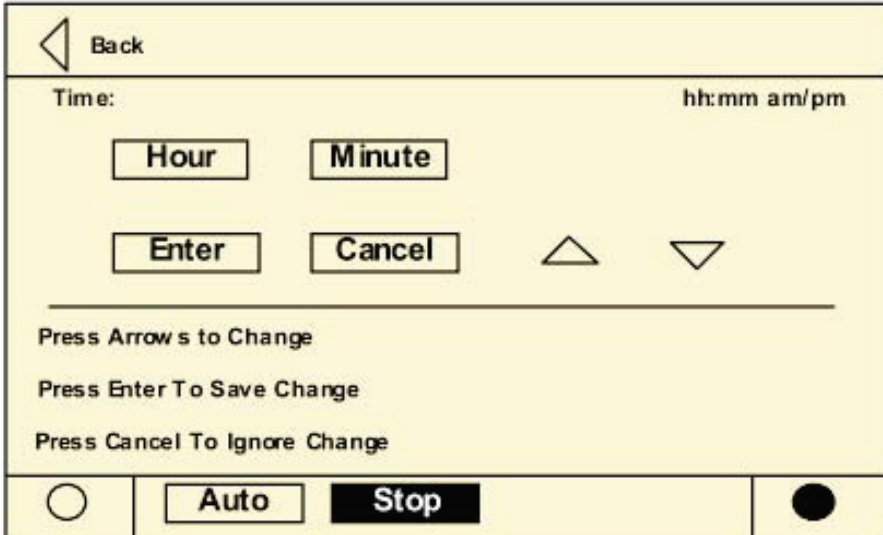



Controls Interface

Power-Up EasyView

Scenario #1: On Power-Up EasyView will progress through two screens if an application is not present.

First Screen, Version # of the Boot, only the version # extension is displayed. This screen will display for 3-5 seconds and move on to the second screen.

Second Screen, Application or No Application. This screen will display “-APP” for as long as it remains powered.

Scenario #2: On Power-Up EasyView will progress through five screens if an application is present.

First Screen, Version # of the Boot, only the version # extension is displayed. This screen will display for 3-5 seconds and move on to the second screen.

Second Screen, Application or No Application. This screen will display “APP” for 3-5 seconds and move on to the third screen.

Third screen, First screen of the Application, segment and LED test. This screen will turn on all LED’s and segments for 3-5 seconds and move on to the fourth screen.

Fourth Screen, splash screen. This screen will display CH530 for 3-5 seconds and move on to the fifth screen.

Fifth Screen, the Leaving Water Temperature.

Power-Up DynaView

On Power-Up, DynaView will progress through three screens:

First Screen, Version # of the Boot, full version # displayed. This screen will display for 5 seconds and move on to the second screen. The contrast will also be adjustable from this screen.

Second Screen, Application or No Application. This screen will display for 5 seconds “A Valid Application Is Present” or “A Valid Application Is Not Present” and move on to the third screen.

Third Screen, First screen of the Application, the Chiller Tab.

Self Tests

On Power-Up, the CH. 530 runs self tests. Error messages that appear should be recorded and reported to a qualified service agency to include “ERR1” or “ERR2” messages on EasyView and a “RAM ERROR” or “Un-Recoverable Error” message on DynaView. Failure may result in flashing of all the LED’s on EasyView and flashing of the back-light on DynaView.

Display Formats Units

Temperature settings are in °F or °C, depending on Display Units settings. Settings can be entered in tenths or whole degrees depending on a menu setting at the TechView. Dashes (“-----”) appearing in a temperature or pressure report, indicates that the value is invalid or not applicable.

Languages

English plus two alternate languages may be installed with DynaView and will reside in the main processor. English will always be available. Alternate languages must be installed using TechView, Software Download View.

TechView Interface

TechView is the PC (laptop) based tool used for servicing Tracer CH530. Technicians that make any chiller control modification or service any diagnostic with Tracer CH530 must use a laptop running the software application “TechView.” TechView is a Trane application developed to minimize chiller downtime and aid the technicians’ understanding of chiller operation and service requirements.

Controls Interface

Important: Performing any Tracer CH530 service functions should be done only by a properly trained service technician. Please contact your local Trane service agency for assistance with any service requirements.

TechView software is available via Trane.com (<http://www.trane.com/commercial/software/tracerch530/>) provides a user the TechView installation software and CH530 main processor software that must be loaded onto your PC in order to service a CH530 main processor. The TechView service tool is used to load software into the Tracer CH530 main processor (DynaView or EasyView). Minimum PC requirements to install and operate TechView are:

- Pentium II or higher processor
- 128Mb RAM
- 1024 x 768 resolution of display
- CD-ROM
- 56K modem
- 9-pin RS-232 serial connection
- Operating system - Windows 2000
- Microsoft Office (MS Word, MS Access, MS Excel)

Note: TechView was designed for the preceding listed laptop configuration. Any variation will have unknown results. Therefore, support for TechView is limited to only those laptops that meet the specific configuration listed here. Only laptops with a Pentium II class processor or better are supported; Intel Celeron, AMD, or Cyrix processors are not supported.

TechView is also used to perform any CH530 service or maintenance function. Servicing a CH530 main processor includes:

- Updating main processor software
- Monitoring chiller operation
- Viewing and resetting chiller diagnostics
- Low Level Intelligent Device (LLID) replacement and binding
- Main processor replacement and configuration modifications
- Setpoint modifications
- Service overrides

Software Download Process

Important Installation Instructions: First Time Users:

- 1 - Proceed to "TechView Software

Download" page and download the latest version of TechView, Java Runtime Environment, emGateway installation files and the MP software. These files should be stored in a folder named "CH530" so they are easy to locate.

2 - For easier recognition, write down the names of all of the files downloaded.

3 - Using your PC's file manager, locate the files you just downloaded.

Note: The files should be located in the CH530 folder.

4 - Install Java Runtime Environment on your PC by running the loaded "JRE_VXXX.exe" file. For example, locate the "JRE_VXXX.exe" file on your PC, then double left click the file to execute the install program. Then follow the installation prompts.

5 - Install emGateway on your PC by running the loaded "emG_VXXX.exe" file. For

example, locate the "emG_VXXX.exe" file on your PC, then double left click the file to execute the install program. Then follow the installation prompts.

Note: A com port MUST be selected since there is no default setting.

6 - Install TechView on your PC by running the loaded "TV_VXXX.exe" file. For example, locate the "TV_VXXX.exe" file on your PC, then double left click the file to execute the install program. Then follow the installation prompts.

7 - Install the MP software, RTAC MP version XX.X.

8 - Connect your PC to the CH530 main processor using a standard 9-pin male/9-pin female RS-232 cable.

9 - Run TechView software by selecting the TechView icon placed on your desktop during the installation process. The "Help...About" menu can be viewed to confirm proper installation of latest versions.

Note: An installation of TechView includes the set of chiller main processor software files available upon that date of the TechView release. It would be necessary to select a chiller main processor only if a later version of chiller main processor software were released. The version of chiller main processor software available in TechView can be determined from the Software Download View screen within TechView.

Controls Interface

Connecting the Laptop to CH530

Once the software is downloaded to the laptop, the laptop can be connected to any CH530 main processor to monitor current conditions, view historical data, or change settings. To connect the laptop:

1 - Connect, using a RS-232 cable, to the laptop and the CH530 main processor serial ports.

Note: The RS-232 serial port on the CH530 is located under the slide door on the bottom of the CH530 interface panel (main processor).

2 - Double click on the TechView icon on the laptop to start the program.

Diagnostics

The following Diagnostic Table contains all diagnostics possible arranged alpha-numerically by the three-digit code assigned to each diagnostic. Not all data is available unless TechView is installed.

Legend to Diagnostics Table

Hex Code: 3-digit code used to uniquely identify diagnostics.

Diagnostic Name: Name of Diagnostic as it appears at DynaView and/or TechView displays.

Target: Defines whether the entire Chiller, the Circuit or the Compressor is affected by this diagnostic. None implies that there is no direct effect to the chiller operation.

Severity: Defines the action of the above effect. Immediate means an instantaneous shutdown of the affected portion. Normal means routine or friendly shutdown of the affected portion. Special Mode means a particular mode of operation is invoked, but without shutdown, and Info means an Informational Note or Warning is generated.

Persistence: Defines whether or not the diagnostic and its effects are to be manually reset (Latched), or can be either manually or automatically reset (Nonlatched).

Active Modes [Inactive Modes]: States the modes or periods of operation that the diagnostic is active and, as necessary, those modes or periods that it is specifically not active as an exception to the active modes. The inactive modes are enclosed in brackets [].

Criteria: Quantitatively defines the criteria used in generating the diagnostic and, if nonlatching, the criteria for auto reset.

Reset Level: Defines the lowest level of manual diagnostic reset command which can clear the diagnostic. The manual diagnostic reset levels in order of priority are: Local, Remote and Info. For example, a diagnostic that has a reset level of Remote, can be reset by either a remote diagnostic reset command or by a local diagnostic reset command, but not by the lower priority Info Reset command.

The following Diagnostic Table contains all diagnostics possible arranged alphabetically by the name assigned to each diagnostic. Not all diagnostics are available unless TechView is installed.

Legend to Diagnostics Table

Hex Code: 3-digit code used to uniquely identify diagnostics.

Diagnostic Name: Name of the diagnostic as it appears at DynaView and/or TechView displays.

Severity: Defines the action of the above effect. Immediate means an instantaneous shutdown of the affected portion. Normal means routine or friendly shutdown of the affected portion. Special Mode means a particular mode of operation is invoked, but without shutdown, and Info means an Informational Note or Warning is generated.

Persistence: Defines whether or not the diagnostic and its effects are to be manually reset (Latched), or can be either manually or automatically reset (Nonlatched).

Criteria: Quantitatively defines the criteria used in generating the diagnostic and, if nonlatching, the criteria for auto reset.

Reset Level: Defines the lowest level of manual diagnostic reset command which can clear the diagnostic. The manual diagnostic reset levels in decreasing order of priority are: Local, Remote and Info. For example, a diagnostic that has a reset level of Remote, can be reset by either a remote diagnostic reset command or by a local diagnostic reset command, but not by the lower priority Info Reset command.

VII-Diagnostics

Tab. VI-01 – Setpoints View Items

Hex Code	Diagnostic Name and Source	Severity	Persistence	Criteria	Reset Level
398	BAS Communication Lost	Special	NonLatch	The BAS was setup as "installed" at the MP and the Comm 3 LLID lost communications with the BAS for 15 contiguous minutes after it had been established. Refer to Section on Setpoint Arbitration to determine how setpoints and operating modes may be effected by the comm loss. The chiller follows the value of the Tracer Default Run Command which can be previously written by Tracer and stored nonvolatily by the MP (either use local or shutdown).	Remote
390	BAS Failed to Establish	Special	NonLatch	The BAS was setup as "installed" and the BAS did not communicate with the MP within 15 minutes after power-up. Refer to Section on Setpoint Arbitration to determine how setpoints and operating modes may be effected. Note: The original requirement for this was 2 minutes, but was implemented at 15 minutes for RTAC	Remote
2E6	Check Clock	Info	Latch	The real time clock had detected loss of its oscillator at some time in the past. This diagnostic can be effectively cleared only by writing a new value to the chiller's time clock using the TechView or DynaView's "set chiller time" functions.	Remote
8A	Chilled Water Flow (Entering)	Info	NonLatch	The entering evaporator water temp fell below the leaving evaporator water temp. by more than 2°F for 100 °F-sec. For RTAC this diagnostic cannot reliably indicate loss of flow, but can warn of improper flow direction through the evaporator, misbound temperature sensors, or other system problems	Remote
5EF	Comm Loss: Chilled Water Flow Switch	Latch		Continual loss of communication between the MP and the Immediate Functional ID has occurred for a 30 second period.	Remote
5F2	Comm Loss: Cond Rfgt	Pressure,	Circuit #1	Immediate Latch Same as Comm Loss: Chilled Water Flow Switch	Remote
694	Comm Loss: Electronic Expansion Valve, Circuit #1	Normal	Latch	Same as Comm Loss: Chilled Water Flow Switch Remote	Remote
695	Comm Loss: Electronic Expansion Valve, Circuit #2	Normal	Latch	Same as Comm Loss: Chilled Water Flow Switch Remote	Remote
5DE	Comm Loss: Emergency Stop	Normal	Latch S	Same as Comm Loss: Chilled Water Flow Switch Remote Stop	Remote
68E	Comm Loss: Evap Oil Return Valve, Cprsr 1A	Normal	Latch	Same as Comm Loss: Chilled Water Flow Switch Remote	Remote
69E	Comm Loss: Evap Oil Return Valve, Cprsr 1B	Normal	Latch	Same as Comm Loss: Chilled Water Flow Switch	Remote
68F	Comm Loss: Evap Oil Return Valve, Cprsr 2A	Normal	Latch	Same as Comm Loss: Chilled Water Flow Switch	Remote
69F	Comm Loss: Evap Oil Return Valve, Cprsr 2B	Normal	Latch	Same as Comm Loss: Chilled Water Flow Switch	Remote
5E4	Comm Loss: Evaporator Entering Water Temperature	Special	Latch	Same as Comm Loss: Chilled Water Flow Switch	Remote
5E3	Comm Loss: Evaporator Leaving Water Temperature	Normal	Latch	Same as Comm Loss: Chilled Water Flow Switch	Remote
6BB	Comm Loss: Evaporator Rfgt Drain Valve - Ckt 1	Normal	Latch	Same as Comm Loss: Chilled Water Flow Switch	Remote
6BC	Comm Loss: Evaporator Rfgt Drain Valve - Ckt 2	Normal	Latch	Same as Comm Loss: Chilled Water Flow Switch	Remote
688	Comm Loss: Evaporator Rfgt Liquid Level, Circuit #1	Immediate	Latch	Same as Comm Loss: Chilled Water Flow Switch	Remote
689	Comm Loss: Evaporator Rfgt Liquid Level, Circuit #2	Immediate	Latch	Same as Comm Loss: Chilled Water Flow Switch	Remote
5F0	Comm Loss: Evaporator Rfgt Pressure, Circuit #1	Immediate	Latch	Continual loss of communication between the MP and he Functional ID has occurred for a 30 second period. Note: This diagnostic is replaced by diagnostic 5FB below with Rev 15.0	Remote
5F1	Comm Loss: Evaporator Rfgt Pressure, Circuit #2	Immediate	Latch	Continual loss of communication between the MP and the Functional ID has occurred for a 30 second period. Note: This diagnostic is replaced by diagnostic 5FD below with Rev 15.0	Remote



Diagnostics

Hex Code	Diagnostic Name and Source	Severity	Persistence	Criteria	Reset Level
5F8	Comm Loss: Evaporator Water Pump Control	Normal	Latch	Same as Comm Loss: Chilled Water Flow Switch	Remote
5DD	Comm Loss: External Auto/ Stop	Normal	Latch	Same as Comm Loss: Chilled Water Flow Switch Remote	Remote
5E9	Comm Loss: External Chilled Water Setpoint	Special Mode	Non Latch	Continual loss of communication between the MP and the Functional ID has occurred for a 30 second period. Chiller shall discontinue use of the External Chilled Water Setpoint source and revert to the next higher priority for setpoint arbitration	Remote
5DF	Comm Loss: External Circuit Lockout, Circuit #1	Special Mode	Latch	Continual loss of communication between the MP and the Functional ID has occurred for a 30 second period. MP will nonvolatily hold the lockout state (enabled or disabled) that was in effect at the time of comm loss.	Remote
5E0	Comm Loss: External Circuit Lockout, Circuit #2	Special Mode	Latch	Same as Comm Loss: External Circuit Lockout, Circuit #1	Remote
5EA	Comm Loss: External Current Limit Setpoint	Special Mode	NonLatch	Continual loss of communication between the MP and the Functional ID has occurred for a 30 second period. Chiller shall discontinue use of the External Current limit setpoint and revert to the next higher priority for Current Limit setpoint arbitration	Remote
680	Comm Loss: Fan Control Circuit #1, Stage #1	Normal	Latch	Same as Comm Loss: Chilled Water Flow Switch	Remote
681	Comm Loss: Fan Control Circuit #1, Stage #2	Normal	Latch	Same as Comm Loss: Chilled Water Flow Switch	Remote
682	Comm Loss: Fan Control Circuit #1, Stage #3	Normal	Latch	Same as Comm Loss: Chilled Water Flow Switch	Remote
683	Comm Loss: Fan Control Circuit #1, Stage #4	Normal	Latch	Same as Comm Loss: Chilled Water Flow Switch	Remote
684	Comm Loss: Fan Control Circuit #2, Stage #1	Normal	Latch	Same as Comm Loss: Chilled Water Flow Switch	Remote
685	Comm Loss: Fan Control Circuit #2, Stage #2	Normal	Latch	Same as Comm Loss: Chilled Water Flow Switch	Remote
686	Comm Loss: Fan Control Circuit #2, Stage #3	Normal	Latch	Same as Comm Loss: Chilled Water Flow Switch	Remote
687	Comm Loss: Fan Control Circuit #2, Stage #4	Normal	Latch	Same as Comm Loss: Chilled Water Flow Switch	Remote
68C	Comm Loss: Fan Inverter Fault, Circuit #1 or Circuit #1, Drive 1	Special Mode	Latch	Continual loss of communication between the MP and the Functional ID has occurred for a 30 second period. Operate the remaining fans as fixed speed fan deck.	Remote
68D	Comm Loss: Fan Inverter Fault, Circuit #1, Drive 2	Special Mode	Latch	Same as Comm Loss: Fan Inverter Fault, Circuit #1 or Circuit #1, .Drive 1.	Remote
69A	Comm Loss: Fan Inverter Fault, Circuit #2 or Circuit #2	Special Mode	Latch	Same as Comm Loss: Fan Inverter Fault, Circuit #1 or Circuit #1, .Drive 1.	Remote
69B	Comm Loss: Fan Inverter Fault, Circuit #2, Drive 2	Special Mode	Latch	Same as Comm Loss: Fan Inverter Fault, Circuit #1 or Circuit #1, .Drive 1.	Remote
68A	Comm Loss: Fan Inverter Power, Circuit #1 or Circuit #1 Drive 1 and 2	Normal	Latch	Same as Comm Loss: Fan Inverter Fault, Circuit #1 or Circuit #1, .Drive 1.	Remote
698	Comm Loss: Fan Inverter Power, Circuit #2 or Circuit #2 or Drive 1 and 2	Normal	Latch	Same as Comm Loss: Fan Inverter Fault, Circuit #1 Drive 1.	Remote
68B	Comm Loss: Fan Inverter Speed Command, Circuit #1 or Circuit #1 Drive 1 and 2	Special Mode	Latch	Same as Comm Loss: Fan Inverter Fault, Circuit #1 or Circuit #1, .Drive 1.	Remote
699	Comm Loss: Fan Inverter or Circuit #2 Drive 1 and 2 Speed Command, Circuit #2	Special Mode	Latch	Same as Comm Loss: Fan Inverter Fault, Circuit #1 or Circuit #1, .Drive 1.	Remote
5D9	Comm Loss: Female Step Load Compressor 1A	Normal	Latch	Same as Comm Loss: Chilled Water Flow Switch	Remote



Diagnostics

Hex Code	Diagnostic Name and Source	Severity	Persistence	Criteria	Reset Level
5DA	Comm Loss: Female Step Load Compressor 1B	Normal	Latch	Same as Comm Loss: Chilled Water Flow Switch	Remote
5DB	Comm Loss: Female Step Load Compressor 2A	Normal	Latch	Same as Comm Loss: Chilled Water Flow Switch	Remote
5DC	Comm Loss: Female Step Load Compressor 2B	Normal	Latch	Same as Comm Loss: Chilled Water Flow Switch	Remote
5EB	Comm Loss: High Pressure Cutout Switch, Cprsr 1A	Immediate	Latch	Same as Comm Loss: Chilled Water Flow Switch	Remote
5EC	Comm Loss: High Pressure Cutout Switch, Cprsr 1B	Immediate	Latch	Same as Comm Loss: Chilled Water Flow Switch	Remote
5ED	Comm Loss: High Pressure Cutout Switch, Cprsr 2A	Immediate	Latch	Same as Comm Loss: Chilled Water Flow Switch	Remote
5EE	Comm Loss: High Pressure Cutout Switch, Cprsr 2B	Immediate	Latch	Same as Comm Loss: Chilled Water Flow Switch	Remote
5E1	Comm Loss: Ice-Machine Control	Special Mode	Latch	Continual loss of communication between the MP and the Functional ID has occurred for a 30 second period. Chiller shall revert to normal (non-ice building) mode regardless of last state.	Remote
5FA	Comm Loss: Ice-Making Status	Special Mode	Latch	Same as Comm Loss: Ice-Machine Control	Remote
5F4	Comm Loss: Intermediate Oil Pressure, Cprsr 1A	Immediate	Latch	Same as Comm Loss: Chilled Water Flow Switch	Remote
5F5	Comm Loss: Intermediate Oil Pressure, Cprsr 1B	Immediate	Latch	Same as Comm Loss: Chilled Water Flow Switch	Remote
5F6	Comm Loss: Intermediate Oil Pressure, Cprsr 2A	Immediate	Latch	Same as Comm Loss: Chilled Water Flow Switch	Remote
5F7	Comm Loss: Intermediate Oil Pressure, Cprsr 2B	Immediate	Latch	Same as Comm Loss: Chilled Water Flow Switch	Remote
69D	Comm Loss: Local BAS Interface	Special Mode	Latch	Same as Comm Loss: Chilled Water Flow Switch	Remote
5D2	Comm Loss: Male Port Load Compressor 1A	Normal	Latch	Same as Comm Loss: Chilled Water Flow Switch	Remote
5D4	Comm Loss: Male Port Load Compressor 1B	Normal	Latch	Same as Comm Loss: Chilled Water Flow Switch	Remote
5D6	Comm Loss: Male Port Load Compressor 2A	Normal	Latch	Same as Comm Loss: Chilled Water Flow Switch	Remote
5D8	Comm Loss: Male Port Load Compressor 2B	Normal	Latch	Same as Comm Loss: Chilled Water Flow Switch	Remote
5D1	Comm Loss: Male Port Unload Compressor 1A	Normal	Latch	Same as Comm Loss: Chilled Water Flow Switch	Remote
5D3	Comm Loss: Male Port Unload Compressor 1B	Normal	Latch	Same as Comm Loss: Chilled Water Flow Switch	Remote
5D5	Comm Loss: Male Port Unload Compressor 2A	Normal	Latch	Same as Comm Loss: Chilled Water Flow Switch	Remote
5D7	Comm Loss: Male Port Unload Compressor 2B	Normal	Latch	Same as Comm Loss: Chilled Water Flow Switch	Remote
5E5	Comm Loss: Oil Temperature, Circuit #1 or Cprsr 1A	Normal	Latch	Same as Comm Loss: Chilled Water Flow Switch	Remote
5E6	Comm Loss: Oil Temperature, Circuit #2 or Cprsr 2A	Normal	Latch	Same as Comm Loss: Chilled Water Flow Switch	Remote
696	Comm Loss: Oil Temperature, Cprsr 1B	Normal	Latch	Same as Comm Loss: Chilled Water Flow Switch	Remote
697	Comm Loss: Oil Temperature, Cprsr 2B	Normal	Latch	Same as Comm Loss: Chilled Water Flow Switch	Remote
5E2	Comm Loss: Outdoor Air Temperature	Normal	Latch	Continual loss of communication between the MP and the Functional ID has occurred for a 30 second period. Note that if this diagnostic occurs, operational pumpdown will be performed regardless of the last valid temperature	Remote
690	Comm Loss: Starter 1A	Immediate	Latch	Same as Comm Loss: Chilled Water Flow Switch	Local
691	Comm Loss: Starter 1B	Immediate	Latch	Same as Comm Loss: Chilled Water Flow Switch	Local
692	Comm Loss: Starter 2A	Immediate	Latch	Same as Comm Loss: Chilled Water Flow Switch	Local
693	Comm Loss: Starter 2B	Immediate	Latch	Same as Comm Loss: Chilled Water Flow Switch	Local
6AC	Comm Loss: Starter Panel High Temperature Limit – Panel 1, Cprsr 1B	Info	Latch	Same as Comm Loss: Chilled Water Flow Switch	Local



Diagnostics

Hex Code	Diagnostic Name and Source	Severity	Persistence	Criteria	Reset Level
6AB	Comm Loss: Starter Panel High Temperature Limit – Panel 1, Cprsr 2A	Info	Latch	Same as Comm Loss: Chilled Water Flow Switch	Local
6AD	Comm Loss: Starter Panel High Temperature Limit – Panel 2, Cprsr 2B	Info	Latch	Same as Comm Loss: Chilled Water Flow Switch	Local
6A0	Comm Loss: Status/Annunciation Relays	Info	Latch	Same as Comm Loss: Chilled Water Flow Switch	Remote
5FB	Comm Loss: Suction Pressure Cprsr 1A	Immediate	Latch	Continual loss of communication between the MP and the Functional ID has occurred for a 30 second period. Circuit target if no isolation valves, Compressor target if isolation valves or simplex. Design Note: In the case of manifolded compressors w/o isolation valves, the occurrence of this diagnostic will also generate a comm loss with the nonexistent Suction Press Cprsr 2B in order to accomplish circuit shutdown.	Remote
5FC	Comm Loss: Suction Pressure Cprsr 1B	Immediate	Latch	Continual loss of communication between the MP and the Functional ID has occurred for a 30 second period. Design Note: For circuits with manifolded compressors w/o isolation valve option, this diagnostic will occur with the preceding diagnostic, even though this transducer is not required or installed.	Remote
5FD	Comm Loss: Suction Pressure Cprsr 2A	Immediate	Latch	Same as Comm Loss: Suction Pressure Cprsr 1A	Remote
5FE	Comm Loss: Suction Pressure Cprsr 2B	Immediate	Latch	Same as Comm Loss: Suction Pressure Cprsr 1B	Remote
2A1	Condenser Fan Variable Speed Drive Fault – Circuit 1 (Drive 1)	Special Mode	Latch	The MP has received a fault signal from the respective condenser fan Variable Speed Inverter Drive, and unsuccessfully attempted (5 times within 1 minute of each other) to clear the fault. The 4th attempt removes power from the inverter to create a power up reset. If the fault does not clear, the MP will revert to constant speed operation without the use of the inverter's fan. The inverter must be manually bypassed, and fan outputs rebound, for full fixed speed fan operation.	Remote
5B4	Condenser Fan Variable Speed Drive Fault – Circuit 1 Drive 2	Special Mode	Latch	Same as Condenser Fan Variable Speed Drive Fault – Circuit 1 (Drive 1)	Remote
2A2	Condenser Fan Variable Speed Drive Fault – Circuit 2 (Drive 1)	Special Mode	Latch	Same as Condenser Fan Variable Speed Drive Fault – Circuit 1 (Drive 1)	Remote
5B5	Condenser Fan Variable Speed Drive Fault – Circuit 2 (Drive 2)	Special Mode	Latch	Same as Condenser Fan Variable Speed Drive Fault – Circuit 1 (Drive 1)	Remote
5B8	Condenser Refrigerant Pressure Transducer – Circuit 1	Immediate	Latch	Bad Sensor or LLID	Remote
5B9	Condenser Refrigerant Pressure Transducer – Circuit 2	Immediate	Latch	Bad Sensor or LLID	Remote
FD	Emergency Stop	Immediate	Latch	EMERGENCY STOP input is open. An external interlock has tripped. Time to trip from input opening to unit stop shall be 0.1 to 1.0 seconds.	Local
8E	Evaporator Entering Water Temperature Sensor	Info	Latch	Bad Sensor or LLID a. Normal operation, no effects on control. b. Chiller shall remove any Return or Constant Return Chilled Water Reset, if it was in effect. Apply slew rates per Chilled Water Reset spec.	Remote
AB	Evaporator Leaving Water Temperature Sensor	Normal	Latch	Bad Sensor or LLID	Remote
27D	Evaporator Liquid Level Sensor – Circuit 1	Immediate	Latch	Bad Sensor or LLID	Remote
3F9	Evaporator Liquid Level Sensor – Circuit 2	Immediate	Latch	Bad Sensor or LLID	Remote
6B9	Evaporator Rfgt Drain - Circuit 1	NA	Latch	This diagnostic is effective only with Remote Evap units. The liquid level of the respective evaporator was not seen to be below the level of -21.2 mm (0.83 in) within 5 minutes of the commanded opening of its Drain Valve Solenoid. The diagnostic will not be active if the drain valve is commanded closed.	Remote
6BA	Evaporator Rfgt Drain - Circuit 2	NA	Latch	Same as Evaporator Rfgt Drain - Circuit 1	Remote
ED	Evaporator Water Flow Lost	Immediate	NonLatch	a. The chilled water flow switch input was open formore than 6-10 contiguous seconds. b. This diagnostic does not de-energize the evap pump output c. 6-10 seconds of contiguous flow shall clear this diagnostic. d. Even though the pump times out in the STOP modes, this diagnostic shall not be called out in the STOP modes. Note that this diagnostic will not light the red diagnostic light on the Easy View display.	Remote

Diagnostics

Hex Code	Diagnostic Name and Source	Severity	Persistence	Criteria	Reset Level
384	Evaporator Water Flow Overdue	Normal	NonLatch	Evaporator water flow was not proven within 4.25 minutes (RTAC Rev 20 and earlier) or 20 minutes (RTAC Rev 21) of the Chilled water pump relay being energized. With SW Rev 170 and earlier, the diagnostic will de-energize the Chilled Water Pump output. It will be re-energized if the diagnostic clears with the return of flow and the chiller will be allowed to restart normally (to accommodate external control of pump) With SW Rev 18.0 and later, the pump command status will not be effected. Note that this diagnostic will not light the red diagnostic light on the EasyView display.	Remote
5C4	Excessive Loss of Comm	Immediate	Latch	Loss of comm with 75% or more of the LLIDs configured for the system has been detected. This diagnostic will suppress the callout of all subsequent comm loss diagnostics. Check power supply(s) and power disconnects - troubleshoot LLIDS buss using TechView	Remote
87	External Chilled Water Setpoint	Info	NonLatch	a. Function Not "Enabled": no diagnostics. b. "Enabled ": Out-Of-Range Low or Hi or bad LLID, set diagnostic, default CWS to next level of priority (e.g. Front Panel SetPoint). This Info diagnostic will automatically reset if the input returns to the normal range.	Remote
89	External Current Limit Setpoint	Info	NonLatch	Same as External Chilled Water Setpoint	Remote
1C6	High Differential Refrigerant Pressure - Circuit 1	Normal	Latch	The system differential pressure for the respective circuit was above 275 Psid for 2 consecutive samples or more than 10 seconds.	Remote
1C7	High Differential Refrigerant Pressure - Circuit 2	Normal	Latch	Same as High Differential Refrigerant Pressure - Circuit 1	Remote
584	High Evaporator Liquid Level - Circuit 1	Normal	Latch	The liquid level sensor is seen to be at or near its high end of range for 80 contiguous minutes while the compressor is running. (The diagnostic timer will hold, but not clear when the circuit is off). Design: 80% or more of bit count corresponding to +21.2 mm or more liquid level for 80 minutes)	Remote
5B7	High Evaporator Liquid Level - Circuit 2	Normal	Latch	Same as High Evaporator Liquid Level - Circuit 1	Remote
6B8	High Evaporator Refrigerant Pressure	Immediate	NonLatch	The evaporator refrigerant pressure of either circuit has risen above 190 psig. The evaporator water pump relay will be de-energized to stop the pump regardless of why the pump is running. The diagnostic will auto reset and the pump will return to normal control when all of the evaporator pressures fall below 185 psig. This diagnostic has severity of Immediate because if an evaporator pressure reads high without being invalid, the pump would be shut off but the chiller could keep running. Evap water flow diagnostics are not active if the pump is commanded off, only if the pump is commanded on but flow does not occur as expected.	Remote
1DE	High Oil Temperature - Compressor 1A	Immediate	Latch	The respective oil temperature as supplied to the compressor, exceeded 200°F for 2 consecutive samples or for over 10 seconds. Note: As part of the Compressor High Temperature Limit Mode (aka Minimum Limit), the running compressor's female load step will be forced loaded when its oil temperature exceeds 190F and returned to normal control when the oil temperature falls below 170°F	Remote
1E0	High Oil Temperature - Compressor 1B	Immediate	Latch	Same as High Oil Temperature - Compressor 1A	Remote
1DD	High Oil Temperature - Compressor 2A	Immediate	Latch	Same as High Oil Temperature - Compressor 1A	Remote
1DF	High Oil Temperature - Compressor 2B	Immediate	Latch	Same as High Oil Temperature - Compressor 1A	Remote
F5	High Pressure Cutout - Compressor 1A	Immediate	Latch	A high pressure cutout was detected on Compressor 1A; trip at 315 ± 5 PSIG. Note: Other diagnostics that may occur as an expected consequence of the HPC trip will be suppressed from annunciation. These include Phase Loss, Power Loss, and Transition Complete Input Open.	Local
F6	High Pressure Cutout - Compressor 1B	Immediate	Latch	Same as High Pressure Cutout - Compressor 1A	Local
BE	High Pressure Cutout - Compressor 2A	Immediate	Latch	Same as High Pressure Cutout - Compressor 1A	Local
BF	High Pressure Cutout - Compressor 2B	Immediate	Latch	Same as High Pressure Cutout - Compressor 1A	Local



Diagnostics

Hex Code	Diagnostic Name and Source	Severity	Persistence	Criteria	Reset Level
5BE	Intermediate Oil Pressure Compressor 2A	Immediate	Latch	Bad Sensor or LLID	Remote
BF	High Pressure Cutout – Compressor 2B	Immediate	Latch	Same as High Pressure Cutout - Compressor 1A	Local
5BE	Intermediate Oil Pressure Transducer - Compressor 1A	Immediate	Latch	Bad Sensor or LLID	Remote
5BF	Intermediate Oil Pressure Transducer - Compressor 1B	Immediate	Latch	Bad Sensor or LLID	Remote
5C0	Intermediate Oil Pressure Transducer - Compressor 2A	Immediate	Latch	Bad Sensor or LLID	Remote
5C1	Intermediate Oil Pressure Transducer - Compressor 2B	Immediate	Latch	Bad Sensor or LLID	Remote
C5	Low Chilled Water Temp: Unit Off	Special Mode	NonLatch	The leaving chilled water temp. fell below the leaving water temp cutout setting for 30 degree F seconds while the Chiller is in the Stop mode, or in Auto mode with no compressors running. Energize Evap Water pump Relay until diagnostic auto resets, then return to normal evap pump control. Automatic reset occurs when the temp rises 2°F (1.1°C) above the cutout setting for 30 minutes.	Remote
C6	Low Chilled Water Temp: Unit On	Immediate and Special Mode	NonLatch	The chilled water temp. fell below the cutout setpoint for 30 degree F Seconds while the compressor was running. Automatic reset occurs when the temperature rises 2 °F (1.1°C) above the cutout setting for 2 minutes. This diagnostic shall not de-energize the Evaporator Water Pump Output.	Remote
1AE	Low Differential Refrigerant Pressure - Circuit 1	Immediate	Latch	The system differential pressure for the respective circuit was below 35 Psid for more than 2000 Psid-sec with either a 1 minute (single cprsr circuit) or 2.5 minute (manifolded cprsr circuit) ignore time from the start of the circuit.	Remote
1AF	Low Differential Refrigerant Pressure - Circuit 2	Immediate	Latch	Same as Low Differential Refrigerant Pressure - Circuit 1	Remote
583	Low Evaporator Liquid Level - Circuit 1	Info	NonLatch	The liquid level sensor is seen to be at or near its low end of range for 80 contiguous minutes while the compressor is running. Design: 20% or less of bit count corresponding to -21.2 mm or less liquid level for 80 minutes)	Remote
5B6	Low Evaporator Liquid Level - Circuit 2	Info	NonLatch	Same as Low Evaporator Liquid Level - Circuit 1	Remote
194	Low Evaporator Refrigerant Temperature - Circuit 1	Immediate	Latch	a. The inferred Saturated Evap Refrigerant Temperature (calculated from suction pressure transducer(s)) dropped below the Low Refrigerant Temperature Cutout Setpoint for 120°F-sec (8°F-sec max rate) while the circuit was running after the ignore period had expired. The integral is held at zero for the ignore time (which is a function of outdoor air temp) following the circuit startup and the integral will be limited to never trip in less than 15 seconds, i.e. the error term shall be clamped to 8°F The minimum LRTC setpoint is -5°F (18.7 Psia) the point at which oil separates from the refrigerant. b. During the timeout of the trip integral, the unload solenoid(s) of the running compressors on the circuit, shall be energized continuously. Normal load/unload operation will be resumed if the trip integral is reset by return to temps above the cutout setpoint.	Remote
195	Low Evaporator Refrigerant Temperature - Circuit 2	Immediate	Latch	Same as Low Evaporator Refrigerant Temperature - Circuit 1	Remote
6B3	Low Evaporator Temp – Ckt 1: Unit Off	Special Mode	NonLatch	Any of the evap sat temps fell below the water temp cutout setting while the respective evap liquid level was greater than -21.2mm for 30 degree F seconds while Chiller is in the Stop mode, or in Auto mode with no compressors running. Energize Evap Water pump Relay until diagnostic auto resets, then return to normal evap pump control. Automatic reset occurs when either the evap temp rises 2°F (1.1°C) above the cutout setting or the liquid level falls below -21.2mm for 30 minutes	Remote
6B3	Low Evaporator Temp – Ckt 2: Unit Off	Special Mode	NonLatch	Same as Low Evaporator Temp - Ckt 1: Unit Off	Remote
198	Low Oil Flow – Compressor 1A	Immediate	Latch	The intermediate oil pressure transducer for this compressor was out of the acceptable pressure range for 15 seconds, while the Delta Pressure was greater than 35 Psid.: Acceptable range is 0.50 > (PC-PI) / (PC-PE) for the first 2.5 minutes of operation, and 0.25 > (PC-PI) / (PC- PE) there after,	Local

Diagnostics

Hex Code	Diagnostic Name and Source	Severity	Persistence	Criteria	Reset Level
199	Low Oil Flow – Compressor 1B	Immediate	Latch	Same as Low Oil Flow - Compressor 1A	Local
19A	Low Oil Flow – Compressor 2A	Immediate	Latch	Same as Low Oil Flow - Compressor 1A	Local
19B	Low Oil Flow – Compressor	Immediate 2B	Latch	Same as Low Oil Flow - Compressor 1A	Local
B5	Low Suction Refrigerant Pressure - Circuit 1	Immediate	Latch	a. The Suction Refrigerant Pressure (or either of the compressor suction pressures) dropped below 10 Psia just prior to compressor start (after EXV preposition). b. The pressure fell below 16 Psia while running after the ignore time had expired, or fell below 10 Psia (or 5 Psia in software prior to Oct'02) before the ignore time had expired. The ignore time is function of outdoor air temperature. Note: Part b. is identical to Low Evaporator Refrigerant Temperature diagnostic except for the trip integral and trip point settings.	Local
B6	Low Suction Refrigerant Pressure - Circuit 2	Immediate	Latch	Same as Low Suction Refrigerant Pressure - Circuit 1	Local
B7	Low Suction Refrigerant Pressure - Cprsr 1B	Immediate	Latch	Same as Low Suction Refrigerant Pressure - Circuit 1	Local
B8	Low Suction Refrigerant Pressure - Cprsr 2B	Immediate	Latch	Same as Low Suction Refrigerant Pressure - Circuit 1	Local
BA	Motor Current Overload – Compressor 1A	Immediate	Latch	Compressor current exceeded overload time vs. trip characteristic. For A/C products Must trip = 140% RLA, Must hold=125%, nominal trip 132.5% in 30 seconds	Local
BB	Motor Current Overload – Compressor 1B	Immediate	Latch	Same as Motor Current Overload - Compressor 1A	Local
BC	Motor Current Overload – Compressor 2A	Immediate	Latch	Same as Motor Current Overload - Compressor 1A	Local
BD	Motor Current Overload – Compressor 2B	Immediate	Latch	Same as Motor Current Overload - Compressor 1A	Local
1AD	MP Application Memory CRC Error	Immediate	Latch	Memory error criteria TBD	Remote
6A1	MP: Could not Store Starts and Hours	Info	Latch	MP has determined there was an error with the previous power down store. Starts and Hours may have been lost for the last 24 hours.	Remote
5FF	MP: Invalid Configuration	Immediate	Latch	MP has an invalid configuration based on the current software installed	Remote
6A2	MP: Non-Volatile Block Test Error	Info	Latch	MP has determined there was an error with a block in the Non-Volatile memory. Check settings.	Remote
69C	MP: Non-Volatile Memory Reformat	Info	Latch	MP has determined there was an error in a sector of the Non-Volatile memory and it was reformatted. Check settings.	Remote
D9	MP: Reset Has Occurred	Info	NonLatch	The main processor has successfully come out of a reset and built its application. A reset may have been due to a power up, installing new software or configuration. This diagnostic is immediately and automatically cleared and thus can only be seen in the Historic Diagnostic List in TechView	Remote
1E1	Oil Flow Fault – Compressor 1A	Immediate	Latch	The Intermediate Oil Pressure Transducer for this cprsr is reading a pressure either above its respective circuit's Condenser Pressure by 15 Psia or more, , or below its respective Suction Pressure 10 Psia or more for 30 seconds continuously.	Local
1E2	Oil Flow Fault – Compressor 1B	Immediate	Latch	Same as Oil Flow Fault - Compressor 1A	Local
5A0	Oil Flow Fault – Compressor 2A	Immediate	Latch	Same as Oil Flow Fault - Compressor 1A	Local
5A1	Oil Flow Fault – Compressor 2B	Immediate	Latch	Same as Oil Flow Fault - Compressor 1A	Local
1E6	Oil Temperature Sensor – Cprsr 1B	Normal	Latch	Bad Sensor or LLID	Remote
1E8	Oil Temperature Sensor – Cprsr 2B	Normal	Latch	Bad Sensor or LLID	Remote
1E6	Oil Temperature Sensor – Cprsr 1A	Normal	Latch	Bad Sensor or LLID	Remote
1E8	Oil Temperature Sensor – Cprsr 2B	Normal	Latch	Bad Sensor or LLID	Remote



Diagnostics

Hex Code	Diagnostic Name and Source	Severity	Persistence	Criteria	Reset Level
1E6	Oil Temperature Sensor – Cprsr 1A	Normal	Latch	Bad Sensor or LLID	Remote
1E7	Oil Temperature Sensor – Cprsr 2A	Normal	Latch	Bad Sensor or LLID	Remote
A1	Outdoor Air Temperature Sensor	Normal	Latch	Bad Sensor or LLID. Note that if this diagnostic occurs, operational pumpdown will be performed regardless of the last valid temperature	Remote
D7	Over Voltage	Normal	NonLatch	a. Line voltage above + 10% of nominal. [Must hold = + 10 % of nominal. Must trip = + 15 % of nominal. Reset differential = min. of 2% and max. of 4%. Time to trip = minimum of 1 min. and maximum of 5 min.) Design: Nom. trip: 60 seconds at greater than 112.5%, + or - 2.5%, Auto Reset at 109% or less.	Remote
19C	Phase Loss – Compressor 1A	Immediate	Latch	a) No current was sensed on one or two of the current transformer inputs while running or starting (See Nonlatching Power Loss Diagnostic for all three phases lost while running). Must hold = 20% RLA. Must trip = 5% RLA. Time to trip shall be longer than guaranteed reset on Starter Module at a minimum, 3 seconds maximum. Actual design trippoint is 10%. The actual design trip time is 2.64 seconds. b) If Phase reversal protection is enabled and current is not sensed on one or more current xformer inputs. Logic will detect and trip in a maximum of 0.3 second from compressor start.	Local
19D	Phase Loss - Compressor 1B	Immediate	Latch	Same as Phase Loss - Compressor 1A	Local
19E	Phase Loss - Compressor 2A	Immediate	Latch	Same as Phase Loss - Compressor 1A	Local
19F	Phase Loss - Compressor 2B	Immediate	Latch	Same as Phase Loss - Compressor 1A	Local
184	Phase Reversal – Compressor 1A	Immediate	Latch	A phase reversal was detected on the incoming current. On a compressor startup the phase reversal logic must detect and trip in a maximum of .3 second from compressor start.	Local
185	Phase Reversal – Compressor 1B	Immediate	Latch	Same as Phase Reversal - Compressor 1A	Local
186	Phase Reversal – Compressor 2A	Immediate	Latch	Same as Phase Reversal - Compressor 1A	Local
187	Phase Reversal – Compressor 2B	Immediate	Latch	Same as Phase Reversal - Compressor 1A	Local
1A0	Power Loss – Compressor 1A	Immediate	NonLatch	The compressor had previously established currents while running and then all three phases of current were lost. Design: Less than 10% RLA, trip in 2.64 seconds. This diagnostic will preclude the Phase Loss Diagnostic and the Transition Complete Input Opened Diagnostic from being called out. To prevent this diagnostic from occurring with the intended disconnect of main power, the minimum time to trip must be greater than the guaranteed reset time of the Starter module. Note: This diagnostic prevents nuisance latching diagnostics due to a momentary power loss - It does not protect motor/compressor from uncontrolled power reapplication. See Momentary Power Loss Diagnostic for this protection. This diagnostic is not active during the start mode before the transition complete input is proven. Thus a random power loss during a start would result in either a "Starter Fault Type 3" or a "Starter Did Not Transition" latching diagnostic.	Remote
1A1	Power Loss - Compressor 1B	Immediate	NonLatch	Same as Power Loss - Compressor 1A	Remote
1A2	Power Loss - Compressor 2A	Immediate	NonLatch	Same as Power Loss - Compressor 1A	Remote
1A3	Power Loss - Compressor 2B	Immediate	NonLatch	Same as Power Loss - Compressor 1A	Remote
8C	Pumpdown Terminated – Circuit 1	Info	NonLatch	The pumpdown cycle for this circuit was terminated abnormally due to excessive time or due to a specific set of diagnostic criteria – but w/o associated latching diagnostics	Remote
8D	Pumpdown Terminated – Circuit 2	Info	NonLatch	Same as Pumpdown Terminated - Circuit 1	Remote
1B2	Severe Current Imbalance – Compressor 1A	Immediate	Latch	A 30% Current Imbalance has been detected on one phase relative to the average of all 3 phases for 90 continuous seconds.	Local
1B3	Severe Current Imbalance – Compressor 1B	Immediate	Latch	Same as Severe Current Imbalance - Compressor 1A	Local
1B4	Severe Current Imbalance – Compressor 2A	Immediate	Latch	Same as Severe Current Imbalance - Compressor 1A	Local
1B5	Severe Current Imbalance – Compressor 2B	Immediate	Latch	Same as Severe Current Imbalance - Compressor 1A	Local
5CD	Starter 1A Comm Loss: MP	Immediate	Latch	Starter has had a loss of communication with the MP for a 15 second period.	Local

Diagnostics

Hex Code	Diagnostic Name and Source	Severity	Persistence	Criteria	Reset Level
6A7	Starter 1A Dry Run Test	Immediate	Latch	While in the Starter Dry Run Mode either 50 % Line Voltage was sensed at the Potential Transformers or 10 % RLA Current was sensed at the Current Transformers.	Local
5CE	Starter 1B Comm Loss: MP	Immediate	Latch	Starter has had a loss of communication with the MP for a 15 second period.	Local
6A8	Starter 1B Dry Run Test	Immediate	Latch	While in the Starter Dry Run Mode either 50 % Line Voltage was sensed at the Potential Transformers or 10 % RLA Current was sensed at the Current Transformers.	Local
5CF	Starter 2A Comm Loss: MP	Immediate	Latch	Starter has had a loss of communication with the MP for a 15 second period.	Local
6A9	Starter 2A Dry Run Test	Immediate	Latch	While in the Starter Dry Run Mode either 50 % Line Voltage was sensed at the Potential Transformers or 10 % RLA Current was sensed at the Current Transformers.	Local
5D0	Starter 2B Comm Loss: MP	Immediate	Latch	Starter has had a loss of communication with the MP for a 15 second period.	Local
6AA	Starter 2B Dry Run Test	Immediate	Latch	While in the Starter Dry Run Mode either 50 % Line Voltage was sensed at the Potential Transformers or 10 % RLA Current was sensed at the Current Transformers.	Local
CC	Starter Contactor Interrupt Failure - Compressor 2A	Special Mode	Latch	Detected compressor currents greater than 10% RLA on any or all phases when the compressor was commanded off. Detection time shall be 5 second minimum and 10 seconds maximum. On detection and until the controller is manually reset: generate diagnostic, energize the appropriate alarm relay, continue to energize the Evap Pump Output, continue to command the affected compressor off, fully unload the effected compressor and command a normal stop to all other compressors. For as long as current continues, perform liquid level and fan control on the circuit effected.	Local
CA	Starter Contactor Interrupt Failure - Compressor 1A	Special Mode	Latch	Same as Starter Contactor Interrupt Failure - Compressor 2A	Local
CB	Starter Contactor Interrupt Failure - Compressor 1B	Special Mode	Latch	Same as Starter Contactor Interrupt Failure - Compressor 2A	Local
CD	Starter Contactor Interrupt Failure - Compressor 2B	Special Mode	Latch	Same as Starter Contactor Interrupt Failure - Compressor 2A	Local
180	Starter Did Not Transition – Compressor 1A	Immediate	Latch	The Starter Module did not receive a transition complete signal in the designated time from its command to transition. The must hold time from the Starter Module transition command is 1 second. The Must trip time from the transition command is 6 seconds. Actual design is 2.5 seconds. This diagnostic is active only for YDelta, Auto-Transformer, Primary Reactor, and X-Line Starters.	Local
181	Starter Did Not Transition – Compressor 1B	Immediate	Latch	Same as Starter Did Not Transition - Compressor 1A	Local
182	Starter Did Not Transition – Compressor 2A	Immediate	Latch	Same as Starter Did Not Transition - Compressor 1A	Local
183	Starter Did Not Transition – Compressor 2B	Immediate	Latch	Same as Starter Did Not Transition - Compressor 1A	Local
6A3	Starter Failed to Arm/Start – Cprsr 1A	Info	Latch	Starter failed to arm or start within the allotted time (15 seconds).	Local
6A4	Starter Failed to Arm/Start – Cprsr 1B	Info	Latch	Same as Starter Failed to Arm/Start - Cprsr 1A	Local
6A5	Starter Failed to Arm/Start – Cprsr 2A	Info	Latch	Same as Starter Failed to Arm/Start - Cprsr 1A	Local
6A6	Starter Failed to Arm/Start – Cprsr 2B	Info	Latch	Same as Starter Failed to Arm/Start - Cprsr 1A	Local
1E9	Starter Fault Type I – Compressor 1A	Immediate	Latch	This is a specific starter test where 1M(1K1) is closed first and a check is made to ensure that there are no currents detected by the CT's. If currents are detected when only 1M is closed first at start, then one of the other contactors is shorted.	Local
1 EA	Starter Fault Type I – Compressor 1B	Immediate	Latch	Same as Starter Fault Type I - Compressor 1A	Local
1 EB	Starter Fault Type I – Compressor 2A	Immediate	Latch	Same as Starter Fault Type I - Compressor 1A	Local
1EC	Starter Fault Type I – Compressor 2B	Immediate	Latch	Same as Starter Fault Type I - Compressor 1A	Local



Diagnostics

Hex Code	Diagnostic Name and Source	Severity	Persistence	Criteria	Reset Level
1ED	Starter Fault Type II – Compressor 1A	Immediate	Latch	a. This is a specific starter test where the Shorting Contactor (1K3) is individually energized and a check is made to ensure that there are no currents detected by the CT's. If current is detected when only S is energized at Start, then 1M is shorted. b. This test in a. above applies to all forms of starters (Note: It is understood that many starters do not connect to the Shorting Contactor.).	Local
1EE	Starter Fault Type II – Compressor 1B	Immediate	Latch	Same as Starter Fault Type II - Compressor 1A	Local
1EF	Starter Fault Type II – Compressor 2A	Immediate	Latch	Same as Starter Fault Type II - Compressor 1A	Local
1F0	Starter Fault Type II – Compressor 2B	Immediate	Latch	Same as Starter Fault Type II - Compressor 1A	Local
1F1	Starter Fault Type III – Compressor 1A	Immediate	Latch	As part of the normal start sequence to apply power to the compressor, the Shorting Contactor (1K3) and then the Main Contactor (1 K1) were energized. 1.6 seconds later there were no currents detected by the CT's for the last 1.2 Seconds on all three phases. The test above applies to all forms of starters except Adaptive Frequency Drives.	Local
1F2	Starter Fault Type III – Compressor 1B	Immediate	Latch	Same as Starter Fault Type III - Compressor 1A	Local
1F3	Starter Fault Type III – Compressor 2A	Immediate	Latch	Same as Starter Fault Type III - Compressor 1A	Local
1F4	Starter Fault Type III – Compressor 2B	Immediate	Latch	Same as Starter Fault Type III - Compressor 1A	Local
5C7	Starter Module Memory Error Type 1 - Starter 2A	Info	Latch	Checksum on RAM copy of the Starter LLID configuration failed. Configuration recalled from EEPROM.	Local
5C8	Starter Module Memory Error Type 1 - Starter 2B	Info	Latch	Same as Starter Module Memory Error Type 1 - Starter 2A	Local
5C5	Starter Module Memory Error Type 1 Starter 1A	Info	Latch	Same as Starter Module Memory Error Type 1 - Starter 2A	Local
5C6	Starter Module Memory Error Type 1-Starter 1B	Info	Latch	Same as Starter Module Memory Error Type 1 - Starter 2A	Local
5C9	Starter Module Memory Error Type 2 - Starter 1A	Immediate	Latch	Same as Starter Module Memory Error Type 1 - Starter 2A	Local
5CA	Starter Module Memory Error Type 2 - Starter 1B	Immediate	Latch	Same as Starter Module Memory Error Type 1 - Starter 2A	Local
5CB	Starter Module Memory Error Type 2 - Starter 2A	Immediate	Latch	Same as Starter Module Memory Error Type 1 - Starter 2A	Local
5CC	Starter Module Memory Error Type 2 - Starter 2B	Immediate	Latch	Same as Starter Module Memory Error Type 1 - Starter 2A	Local
6B1	Starter Panel High Temperature Limit – Panel 1, Cprsr 1B	Special Mode	NonLatch	Starter Panel High Limit Thermostat (170°F) trip was detected. Note: Other diagnostics that may occur as an expected consequence of the Panel High Temp Limit trip will be suppressed from annunciation. These include Phase Loss, Power Loss, and Transition Complete Input Open for Cprsr 1B	Local
6B0	Starter Panel High Temperature Limit – Panel 1, Cprsr 2A	Special Mode	NonLatch	Same as Starter Panel High Temperature Limit - Panel 1, Cprsr 1B	Local
6B2	Starter Panel High Temperature Limit – Panel 2, Cprsr 2B	Special Model	NonLatch	Same as Starter Panel High Temperature Limit - Panel 1, Cprsr 1B	Local
5BA	Suction Refrigerant Pressure Transducer – Circuit 1, Compressor 1A	Immediate	Latch	Bad Sensor or LLID Circuit target if no isolation valves, Compressor target if isolation valves. Design Note: In the case of manifolded compressors w/o isolation valves, the occurrence of this diagnostic will also generate a comm loss with the nonexistent Suction Press Cprsr 1B in order to accomplish circuit shutdown.	Remote
5BB	Suction Refrigerant Pressure Transducer – Circuit 1, Compressor 1B	Immediate	Latch	Same as Suction Refrigerant Pressure Transducer - Circuit 1, Compressor 1A	Remote
5BC	Suction Refrigerant Pressure Transducer - Circuit 2, Compressor 2A	Immediate	Latch	Same as Suction Refrigerant Pressure Transducer - Circuit 1, Compressor 1A	Remote
5BD	Suction Refrigerant Pressure Transducer - Circuit 2, Compressor 2B	Immediate	Latch	Same as Suction Refrigerant Pressure Transducer - Circuit 1, Compressor 1A	Remote

Diagnostics

Hex Code	Diagnostic Name and Source	Severity	Persistence	Criteria	Reset Level
5B0	Transition Complete Input Opened - Compressor 1A	Immediate	Latch	The Transition Complete input was found to be opened with the compressor motor running after a successful completion of transition. This is active only for YDelta, Auto-Transformer, Primary Reactor, and X-Line Starters. To prevent this diagnostic from occurring as the result of a power loss to the contactors, the minimum time to trip must be greater than the trip time for the power loss diagnostic.	Local
5B1	Transition Complete Input Opened - Compressor 1B	Immediate	Latch	Same as Transition Complete Input Opened - Compressor 1A	Local
5B2	Transition Complete Input Opened - Compressor 2A	Immediate	Latch	Same as Transition Complete Input Opened - Compressor 1A	Local
5B3	Transition Complete Input Opened - Compressor 2B	Immediate	Latch	Same as Transition Complete Input Opened - Compressor 1A	Local
5AC	Transition Complete Input Shorted - Compressor 1A	Immediate	Latch	The Transition Complete input was found to be shorted before the compressor was started. This is active for all electromechanical starters.	Local
5AD	Transition Complete Input Shorted - Compressor 1B	Immediate	Latch	Same as Transition Complete Input Opened - Compressor 2B	Local
5AE	Transition Complete Input Shorted - Compressor 2A	Immediate	Latch	Same as Transition Complete Input Opened - Compressor 2B	Local
5AF	Transition Complete Input Shorted - Compressor 2B	Immediate	Latch	Same as Transition Complete Input Opened - Compressor 2B	Local
D8	Under Voltage	Normal	NonLatch	a. Line voltage below - 10% of nominal or the Under/Overvoltage transformer is not connected. [Must hold = - 10 % of nominal. Must trip = - 15 % of nominal. Reset differential = min. of 2% and max. of 4%. Time to trip = min. of 1 min. and max. of 5 min.) Design: Nom. trip: 60 seconds at less than 87.5%, + or - 2.8% at 200V or + or - 1.8% at 575V, Auto Reset at 90% or greater.	Remote
771	Very Low Evaporator Refrigerant Pressure – Circuit 1	Immediate	Latch	The evaporator pressure dropped below 10 psia (or 5 psia in software prior to Oct '02) regardless of whether or not compressors are running on that circuit. This diagnostic was created to prevent compressor failures due to crossbinding by forcing an entire chiller shutdown. If a given compressor or circuit is locked out, the suction pressure transducer(s) associated with it, will be excluded from causing this diagnostic.	Local
772	Very Low Evaporator Refrigerant Pressure – Circuit 2	Immediate	Latch	Same as Very Low Evaporator Refrigerant Pressure - Circuit 1	Local



VIII-Pre-Start Checkout

Installation Checklist

Complete this checklist as the unit is installed and verify that all recommended procedures are accomplished before the unit is started. This checklist does not replace the detailed instructions given in the "Installation - Mechanical" and "Installation - Electrical" sections of this manual. Read both sections completely, to become familiar with the installation procedures, prior to beginning the work.

Receiving

- Verify that the unit nameplate data corresponds to the ordering information.
- Inspect the unit for shipping damage and any shortages of materials. Report any damage or shortage to the carrier.

Unit Location and Mounting

- Inspect the location desired for installation and verify adequate service access clearances.
- Provide drainage for evaporator water.
- Remove and discard all shipping materials (cartons, etc.)
- Install optional rubber isolators, if required.
- Level the unit and secure it to the mounting surface.

Unit Piping

- Flush all water piping before making final connections to the unit.

CAUTION

Proper Water Treatment!

The use of untreated or improperly treated water in the Unit may result in scaling, erosion, corrosion, algae or slime. It is recommended that the services of a qualified water treatment specialist be engaged to determine what water treatment, if any, is required. Trane assumes no responsibility for equipment failures which result from untreated or improperly treated water, or saline or brackish water.

If using an acidic commercial flushing solution, construct a temporary bypass around the unit to prevent damage to internal components of the evaporator.

- **Connect the chilled water piping to the evaporator.**
- Install pressure gauges and shutoff valves on the chilled water inlet and outlet to the evaporator.
- Install a water strainer in the entering chilled water line.

- Install a balancing valve and flow switch (recommended) in the leaving chilled water line.
- Install a drain with shutoff valve or a drain plug on the evaporator waterbox.
- Vent the chilled water system at high points in the system piping.
- Apply heat tape and insulation, as necessary, to protect all exposed piping from freeze-up.

Electrical Wiring

WARNING

Hazardous Voltage w/Capacitors!

Disconnect all electric power, including remote disconnects before servicing. Follow proper lockout/tagout procedures to ensure the power cannot be inadvertently energized. For variable frequency drives or other energy storing components provided by Trane or others, refer to the appropriate manufacturer's literature for allowable waiting periods for discharge of capacitors. Verify with an appropriate voltmeter that all capacitors have discharged. Failure to disconnect power and discharge capacitors before servicing could result in death or serious injury.

Note: For additional information regarding the safe discharge of capacitors.

Live Electrical Components!

During installation, testing, servicing and troubleshooting of this product, it may be necessary to work with live electrical components. Have a qualified licensed electrician or other individual who has been properly trained in handling live electrical components perform these tasks. Failure to follow all electrical safety precautions when exposed to live electrical components could result in death or serious injury.

CAUTION

Use Copper Conductors Only!

Unit terminals are not designed to accept other types of conductors. Failure to use copper conductors may result in equipment damage.

- Connect the unit power supply wiring with fused-disconnect to the terminal block or lugs (or unit-mounted disconnect) in the power section of the control panel.

Pre-Start Checkout

- Connect power supply wiring to the evaporator heaters.
- Connect power supply wiring to the chilled water pump.
- Connect power supply wiring to any auxiliary heat tapes.
- Connect the flow switch and then connect to the proper terminals.
- Connect the chilled water pump to the proper terminals.
- For the External Auto/Stop function, install wiring from remote contacts (5K14, 5K15) to the proper terminals on the circuit board.
- Connect the power supply for the convenience outlet, if it is separate from the evaporator heater.

CAUTION

Information in Interconnecting Wiring!

Chilled Water Pump Interlock and External Auto/Stop must be adhered to or equipment damage may occur.

- If alarm and status relay outputs are used, install leads from the panel to the proper terminals on circuit board.
- If the emergency stop function is used, install low voltage leads to terminals on circuit board.
- Connect separate power for the External Emergency Stop option, if applicable.
- If the ice making-option is used, install leads on 5K18 to the proper terminals on 1U7.
- Connect separate power supply for ice making status circuit, if applicable.

General

When installation is complete, but prior to putting the unit into service, the following pre-start procedures must be reviewed and verified correct:

WARNING

Hazardous Voltage w/Capacitors! Disconnect all electric power, including remote disconnects before servicing. Follow proper lockout/tagout procedures to ensure the power cannot be inadvertently energized. For variable frequency drives or other energy storing components provided by Trane or others, refer to the appropriate manufacturer's literature for allowable waiting periods for discharge of capacitors. Verify with an appropriate voltmeter that all capacitors have discharged. Failure

to disconnect power and discharge capacitors before servicing could result in death or serious injury. Note: For additional information regarding the safe discharge of capacitors.

1. Inspect all wiring connections in the compressor power circuits (disconnects, terminal block, contactors, compressor junction box terminals, etc.). to be sure they are clean and tight.

CAUTION

Connections!

Verify all connections are made. Loose connections can cause overheating and undervoltage conditions at the compressor motor.

2. Open all refrigerant valves in the discharge, liquid, suction, oil and oil return lines.

CAUTION

Compressor Damage!

Catastrophic damage to the compressor will occur if the oil line shut off valve or the isolation valves are left closed on unit start-up.

3. Check the power supply voltage to the unit at the main power fused-disconnect switch. Voltage must be within the voltage utilization range and also stamped on the unit nameplate. Voltage imbalance must not exceed 3%.

4. Check the unit power phasing L1-L2-L3 in the starter to be sure that it has been installed in an "ABC" phase sequence.

5. Fill the evaporator chilled water circuit. Vent the system while it is being filled. Open the vents on the top of the evaporator waterbox while filling and close when filling is completed.

CAUTION

Proper Water Treatment!

The use of untreated or improperly treated water in the unit may result in scaling, erosion, corrosion, algae or slime. It is recommended that the services of a qualified water treatment specialist be engaged to determine what water treatment, if any, is required. Trane assumes no responsibility for equipment failures which

Pre-Start Checkout

result from untreated or improperly treated water, or saline or brackish water.

CAUTION

Use Piping Strainers!

To prevent evaporator damage, pipe strainers must be installed in the water supplies to protect components from water born debris. Trane is not responsible for equipment-only-damage caused by water born debris.

6. Close the fused-disconnect switch(es) that supplies power to the chilled water pump starter.

7. Start the chilled water pump to begin circulation of the water. Inspect all piping for leakage and make any necessary repairs.

8. With water circulating through the system, adjust water flow and check water pressure drop through the evaporator.

9. Adjust the chilled water flow switch for proper operation.

10. Reapply power to complete procedures.

11. Prove all Interlock and Interconnecting Wiring Interlock and External as described in the Electrical Installation section.

12. Check and set, as required, all CH530 menu items.

13. Stop the chilled water pump.

14. Energize compressor and oil separator heaters 24 hours prior to unit start-up.

Unit Voltage Power Supply

Voltage to the unit must meet the criteria given in the Installation-Electrical Section. Measure each leg of the supply voltage at the unit's main power fused-disconnect. If the measured voltage on any leg is not within specified range, notify the supplier of the power and correct the situation before operating the unit

CAUTION

Equipment Damage!

Provide adequate voltage to the unit. Failure to do so can cause control components to malfunction and shorten the life of relay contact, compressor motors and contactors.

Unit Voltage Imbalance

Excessive voltage imbalance between the phases of three-phase system can cause motors to overheat and eventually fail. The maximum allowable imbalance is 3%. Voltage imbalance is determined using the following calculations:

$$\% \text{ Imbalance} = [(V_x - V_{\text{ave}}) \times 100] / V_{\text{ave}}$$

$$V_{\text{ave}} = (V_1 + V_2 + V_3) / 3$$

V_x = phase with the greatest difference from V_{ave} (without regard to the sign)

For example, if the three measured voltages are 221, 230, and 227 volts, the average would be:

$$(221 + 230 + 227) / 3 = 226$$

The percentage of the imbalance is then:

$$[100(221 - 226)] / 226 = 2.2\%$$

This exceeds the maximum allowable

(2%) by 0.2 percent.

Unit Voltage Phasing

CAUTION

Compressor Damage!

It is imperative that L1, L2, L3 in the starter be connected in the A-B-C phase sequence to prevent equipment damage due to reverse rotation.

It is important that proper rotation of the compressors be established before the unit is started. Proper motor rotation requires confirmation of the electrical phase sequence of the power supply. The motor is internally connected for clockwise rotation with the incoming power supply phased A, B, C.

Basically, voltages generated in each phase of a polyphase alternator or circuit are called phase voltages. In a three-phase circuit, three sine wave voltages are generated, differing in phase by 120 electrical degrees. The order in which the three voltages of a three-phase system succeed one another is called phase sequence or phase rotation. This is determined by the direction of rotation of the alternator. When rotation is clockwise, phase sequence is usually called "ABC," when counter clock-wise, "CBA." This direction may be reversed outside the alternator by interchanging any two of the line wires. It is this possible interchange of wiring that makes a phase sequence indicator necessary if the operator is to quickly determine the phase rotation of the motor.

Proper compressor motor electrical phasing can be quickly determined and corrected before starting the unit. Use a quality instrument, such as the Associated Research Model 45 Phase Sequence Indicator, and follow this procedure.

1. Press the STOP key on the CH530.

Pre-Start Checkout

2. Open the electrical disconnect or circuit protection switch that provides line power to the line power terminal block(s) in the starter panel (or to the unit-mounted disconnect).

WARNING

Hazardous Voltage w/Capacitors!
Disconnect all electric power, including remote disconnects before servicing. Follow proper lockout/tagout procedures to ensure the power cannot be inadvertently energized. For variable frequency drives or other energy storing components provided by Trane or others, refer to the appropriate manufacturer's literature for allowable waiting periods for discharge of capacitors. Verify with an appropriate voltmeter that all capacitors have discharged. Failure to disconnect power and discharge capacitors before servicing could result in death or serious injury.

Note: For additional information regarding the safe discharge of capacitors.

3. Connect the phase sequence indicator leads to the line Power terminal block, as follows:

Tab. VIII-01 Dimensión del cable vs. extensión máxima

Phase Seq. Lead	Terminal
Black (Phase A)	L1
Red (Phase B)	L2
Yellow (Phase C)	L3

4. Turn power on by closing the unit supply power fused-disconnect switch.

5. Read the phase sequence on the indicator. The "ABC" LED on the face of the phase indicator will glow if phase is "ABC."

6. If the "CBA" indicator glows instead, open the unit main power disconnect and switch two line leads on the line power terminal block(s) (or the unit mounted disconnect). Re-close the main power disconnect and recheck the phasing.

CAUTION

Compressor Damage!
Do not interchange any load leads that are from the unit contactors or the motor terminals. Doing so may damage the equipment.

7. Reopen the unit disconnect and disconnect the phase indicator.

Water System Flow Rates

Establish a balanced chilled water flow through the evaporator. The flow rates should fall between the minimum and maximum values given on the pressure drop curves.

Chilled water flow rates below the minimum values will result in laminar flow, which reduces heat transfer and causes either loss of EXV control or repeated nuisance, low temperature, cutouts. Flow rates that are too high can cause tube erosion in the evaporator.

Water System Pressure Drop

Measure water pressure drop through the evaporator at the field-installed pressure taps on the system water piping. Use the same gauge for each measurement. Do not include valves, strainers fittings in the pressure drop readings.

Pressure drop readings should be approximately those shown in the Pressure Drop Charts in the Mechanical Installation section.

CH530 Set-Up

Use of TechView service tool is required to view and adjust most settings. Refer to the Controls Interface section for instruction on adjustment of the settings.

Daily Unit Start-Up

The time line for sequence of operation is shown at the end of this section and depicts the nominal delays and sequences that a chiller would experience during a typical operational cycle. The time line begins with a power up of the main power to the chiller. The sequence assumes a 2 circuit, 2 compressor air-cooled RTAC chiller with no diagnostics or malfunctioning components. External events such as the operator placing the chiller in Auto or Stop, chilled water flow through the evaporator, and application of load to the chilled water loop causing loop water temperature increases are depicted and the chillers responses to those events are shown, with appropriate delays noted. The effects of diagnostics, and other external interlocks other than evaporator water flow proving, are not considered.



IX-Unit Start-Up Procedures

The response of the EasyView Display is also depicted on the time line.

NOTE: Unless the CH530 TechView and building automation system are controlling the chilled water pump, the manual unit start sequence is as follows. Operator actions are noted.

CAUTION

Compressor Damage!

Ensure that the compressor and oil separator heaters have been operating for a minimum of 24 hours before starting. Failure to do so may result in equipment damage.

General

If the pre-start checkout, has been completed, the unit is ready to start.

1. Press the STOP key on the CH530.
2. As necessary, adjust the setpoint values in the CH530 menus using TechView.
3. Close the fused-disconnect switch for the chilled water pump. Energize the pump(s) to start water circulation.
4. Check the service valves on the discharge line, suction line, oil line and liquid line for each circuit. These valves must be open (backseated) before starting the compressors.

CAUTION

Compressor Damage!

Catastrophic damage to the compressor will occur if the oil line shut off valve or the isolation valves are left closed on unit start-up.

5. Press the AUTO key. If the chiller control calls for cooling and all safety interlocks are closed, the unit will start. The compressor(s) will load and unload in response to the leaving chilled water temperature.
6. Verify that the chilled water pump runs for at least one minute after the chiller is commanded to stop (for normal chilled water systems).

Once the system has been operating for approximately 30 minutes and has become stabilized, complete the remaining start-up procedures, as follows:

1. Check the evaporator refrigerant

pressure and the condenser refrigerant pressure under Refrigerant Report on the CH530 TechView. The pressures are referenced to sea level (14.6960 psia).

2. Check the EXV sight glasses after sufficient time has elapsed to stabilize the chiller. The refrigerant flow past the sight glasses should be clear. Bubbles in the refrigerant indicate either low refrigerant charge or excessive pressure drop in the liquid line or a stuck open expansion valve. A restriction in the line can sometimes be identified by a noticeable temperature differential between the two sides of the restriction. Frost will often form on the line at this point. Proper refrigerant charges are shown in the General Information Section.

NOTE: Important! A clear sight glass alone does not mean that the system is properly charged. Also check system subcooling, liquid level control and unit operating pressures.

3. Measure the system subcooling.
4. A shortage of refrigerant is indicated if operating pressures are low and subcooling is also low. If the operating pressures, sight glass, superheat and subcooling readings indicate a refrigerant shortage, gas-charge refrigerant into each circuit, as required. With the unit running, add refrigerant vapor by connecting the charging line to the suction service valve and charging through the backseat port until operating conditions become normal.

CAUTION

Refrigerant!

If both suction and discharge pressures are low but sub-cooling is normal, a problem other than refrigerant shortage exists. Do not add refrigerant, as this may result in overcharging the circuit.

Use only refrigerants specified on the unit nameplate (HFC 134a) and Trane OIL00048. Failure to do so may cause compressor damage and improper unit operation.

Unit Start-Up Procedures

Seasonal Unit Start-Up Procedure

1. Close all valves and reinstall the drain plugs in the evaporator.
2. Service the auxiliary equipment according to the start-up/maintenance instructions provided by the respective equipment manufacturers.
3. Close the vents in the evaporator chilled water circuits.
4. Open all the valves in the evaporator chilled water circuits.
5. Open all refrigerant valves to verify they are in the open condition.
6. If the evaporator was previously drained, vent and fill the evaporator and chilled water circuit. When all air is removed from the system (including each pass), install the vent plugs in the evaporator water boxes.
7. Check the adjustment and operation of each safety and operating control.
8. Close all disconnect switches.
9. Refer to the sequence for daily unit startup for the remainder of the seasonal start-up.

System Restart After Extended Shutdown

Follow the procedures below to restart the unit after extended shutdown:

1. Verify that the liquid line service valves, oil line, compressor discharge service valves and suction service valves are open (backseated).

CAUTION

Compressor Damage!

Catastrophic damage to the compressor will occur if the oil line shut off valve or the isolation valves are left closed on unit start-up.

2. Check the oil separator oil level (see Maintenance Procedures section).
3. Fill the evaporator water circuit. Vent the system while it is being filled. Open the vent on the top of the evaporator and condenser while filling and close when filling is completed.

CAUTION

Proper Water Treatment!

The use of untreated or improperly treated water in the unit may result in scaling, erosion, corrosion, algae or slime. It is recommended that the services of a qualified water treatment specialist be engaged to determine what water treatment, if any, is required. Trane assumes no responsibility for equipment failures which result from untreated or improperly treated water, or saline or brackish water.

4. Close the fused-disconnect switches that provides power to the chilled water pump.
5. Start the evaporator water pump and, while water is circulating, inspect all piping for leakage. Make any necessary repairs before starting the unit.
6. While the water is circulating, adjust the water flows and check the water pressure drops through the evaporator. Refer to “Water System Flow Rates” and “Water System Pressure Drop”.
7. Adjust the flow switch on the evaporator piping for proper operation.
8. Stop the water pump. The unit is now ready for start-up as described in “Start-Up Procedures”.

Temporary Shutdown And Restart

To shut the unit down for a short time, use the following procedure:

1. Press the STOP key on the CH530. The compressors will continue to operate and, after an unloading period (which may be followed by pumpdown cycle in outdoor ambients below 50oF), will stop when the compressor contactors de-energize.

2. CH530 pump control will turn off the pump (after a minimum 1 min. delay) when the STOP key is pressed and automatically restart the pump when the unit starts normally.

3. The unit will start normally, provided the following conditions exist:

– The CH530 receives a call for cooling and the differential-to-start is above the setpoint.



Unit Start-Up Procedures

- All system operating interlocks and safety circuits are satisfied.

Extended Shutdown Procedure

The following procedure is to be followed if the system is to be taken out of service for an extended period of time, e.g. seasonal shutdown:

1. Test the unit for refrigerant leaks and repair as necessary.
2. Open the electrical disconnect switches for the chilled water pump. Lock the switches in the "OPEN" position.

CAUTION

Chilled Water Pump!

Lock the chilled water pump disconnects open, to prevent pump damage.

3. Close all chilled water supply valves. Drain the water from the evaporator.

4. With the water drained from evaporator, the "customer provided" power for the 120-volt evaporator heaters (terminated at 1TB4...terminals 1 & 2) must be disconnected. These heaters consist of 1 well heater in each evaporator end (or water box), and the heat tape, which is wrapped around the bundle itself. They are energized by a Klaxon temperature control mounted on the side of the evaporator, which energizes at or below 37°F. outside air temp. If there is no liquid in the evaporator and the temp drops below 37 degrees, both of the well heaters will burn up because they have no liquid to transfer their heat into.

5. Open the unit main electrical disconnect and unit-mounted disconnect (if installed) and lock on the "OPEN" position. If the optional control power transformer is not installed, open and lock the 115V disconnect.

CAUTION

Disconnect Power!

Lock the disconnects in the "OPEN" position to prevent accidental start-up and damage to the system when it has been setup for extended shutdown.

6. At least every three months (quarterly), check the refrigerant pressure in the unit to verify that the refrigerant charge is intact.

X-Periodic Maintenance

Perform all maintenance procedures and inspections at the recommended intervals. This will prolong the life of the chiller and minimize the possibility of costly failures.

Use an “Operator’s Log”, such as that shown at the end of the section, to record an operating history for the unit. The log serves as a valuable diagnostic tool for service personnel. By observing trends in operating conditions, an operator can anticipate and prevent problem situations before they occur. If the unit does not operate properly during maintenance inspections, refer to “Diagnostics and Troubleshooting”.

After the unit has been operating for approximately 30 minutes and the system has stabilized, check the operating conditions and complete the procedures below:

Weekly Maintenance

While unit is running in stable conditions.

1. Check MP pressure for evaporator, condenser and intermediate oil.
2. Observe liquid line sight glass on EXV.
3. If liquid line sight glass has bubbles measure the subcooling entering the EXV.

The subcooling should never be less than 4 °F under any circumstances.

A clear sightglass alone does not mean that the system is properly charged. Also check the rest of the system operating conditions.

4. Inspect the entire system for unusual conditions and inspect the condenser coils for dirt and debris. If the coils are dirty, refer to coil cleaning.

Monthly Maintenance

1. Perform all weekly maintenance procedures.
2. Record the system subcooling.
3. Make any repairs necessary.

Annual Maintenance

1. Perform all weekly and monthly procedures.
2. Check oil sump oil level while unit is off.

NOTE: Routine changing of the oil is not required. Use an oil analysis to determine the condition of the oil.

3. Have a qualified laboratory perform a compressor oil analysis to determine system moisture content and acid level. This analysis is a valuable diagnostic tool.

4. Contact a qualified service organization to leak test the chiller, to check operating and safety controls, and to inspect electrical components for deficiencies.

5. Inspect all piping components for leakage and damage. Clean out any in-line strainers.

6. Clean and repaint any areas that show signs of corrosion.

7. Clean the condenser coils.

WARNING

Hazardous Voltage w/Capacitors!
Disconnect all electric power, including remote disconnects before servicing. Follow proper lockout/tagout procedures to ensure the power cannot be inadvertently energized. For variable frequency drives or other energy storing components provided by Trane or others, refer to the appropriate manufacturer’s literature for allowable waiting periods for discharge of capacitors. Verify with an appropriate voltmeter that all capacitors have discharged. Failure to disconnect power and discharge capacitors before servicing could result in death or serious injury.

Note: For additional information regarding the safe discharge of capacitors.

8. Check and tighten all electrical connections as necessary.



Periodic Maintenance

RTAC Start-up Test Log			
Job Name		Job Location	
Model #			
CRC #		Serial #	
Sales Order #	Ship Date	Job Elevation (ft. above sea level)	
Starter Data:		Start-up Only	
Manufacturer		Chiller Appearance on arrival:	
Type: (wye-delta or x-line)		Machine gauge pressure:	ckt1/ckt2
Vendor ID #/ Model #:		Machine CH.530 pressure	ckt1/ckt2
Volts	Amps	Hz	Unit R-134a Charge lbs
Compressor Data:		Unit oil charge (OIL00048) gal	
Compressor A:		Pressure Test (if required)	
	Model #:	Vacuum after leak test= mm	
	Serial #	Standing Vacuum test= mm rise in hrs	
	RLA	Current Transformers	
	KW	Part number ("X" code and 2-digit extension)	
	Volts	X	
	HZ	X	
Compressor B:		X	
	Model #:	X	
	Serial #	X	
	RLA	X	
	KW	Summary of Options Installed	
	Volts	Y N	Tracer Communications Interface
	HZ	Y N	Ice Making
Compressor C:		Y N	Other
	Model #:	Y N	Other
	Serial #	Y N	Other
	RLA	Evap Design Conditions	
	KW	GPM	PSID
	Volts	Entering Water:	Leaving Water:
	HZ	% Glycol:	
Compressor D:		Type of Glycol:	
	Model #:		
	Serial #	Evap Actual Conditions	
	RLA	GPM	PSID
	KW	Entering Water:	Leaving Water:
	Volts	% Glycol:	
	HZ	Type of Glycol:	



Periodic Maintenance

RTAC Unit Configuration		
Job Name		Job Location
Model #		
Serial #		CRC#
Sales Order #	Ship Date	Job Elevation (ft. above sea level)
Setpoint View *		
Front Panel Degree Units (circle one)		F or C
Front Panel Chilled Water Setpoint		
Front Panel Current Limit		
Differential to Stop		
Differential to Start		
Leaving Water Temperature Cutout		
Low Refrigerant Temperature Cutout		
Condenser Limit		
Low Ambient Lockout Setpoint		
Low Ambient Lockout (circle one)		Enable or Disable
Under/Over Voltage Protection		Enable or Disable
Local Atmospheric Pressure		psi
Design Delta T		F or C
Reset Type (circle one)		None Return Reset Type Outdoor Air Temp. Constant Return
Return Reset Ratio		%
Return Start Reset		
Return Max Reset		
Outdoor Reset Ratio		%
Outdoor Start Reset		
Outdoor Max Reset		
Chilled Water Pump Delay Time		minutes
Chilled Water Setpoint Filtering Settling Time		sec
Compressor Staging Deadband		
Compressor Service View **		
Unit Status:		
Circuit 1 Control		
Front Panel Circuit Lockout (circle one)		Locked or Unlocked
Electronic Expansion Valve (circle one)		Open or Auto
Circuit 2 Control		
Front Panel Circuit Lockout (circle one)		Locked or Unlocked
Electronic Expansion Valve (circle one)		Open or Auto
Configuration ***		
Nameplate		
Model #		
Confirm Code		
Serial Number		

Note:

* Using Techview, click on "View" and then click "Setpoint View" Log accordingly.

** Using Techview, click on "View" and then click "Compressor Service View" Log accordingly.

*** Using Techview, click on "View" and then click "Configuration" (Nameplate Tab) Log accordingly.



Periodic Maintenance

RTAC Chiller Log						
Job Name				Job Location		
Model #				Serial #		
Status View: *						
Chiller Tab:	15 min	30 min	45 min	15 min	30 min	45 min
Operating Mode						
Outdoor Air Temperature <i>F or C</i>						
Active Chill Water Setpoint <i>F or C</i>						
Active Current Limit Setpoint						
Evaporator Entering Water Temp. <i>F or C</i>						
Evaporator Leaving Water Temp. <i>F or C</i>						
	Circuit 1 Tab			Circuit 2 Tab		
External Hardwired Lockout	Not Locked out/ Locked out			Not Locked out/ Locked out		
Front Panel Lockout	Not Locked out/ Locked out			Not Locked out/ Locked out		
	15 min	30 min	45 min	15 min	30 min	45 min
AirFlow <i>%</i>						
Inverter Speed <i>%</i>						
Condenser Refrigerant Pressure <i>psig/kPa</i>						
Saturated Condenser Rfgt. Temp. <i>F or C</i>						
Differential Refrigerant Pressure <i>psid/kPA</i>						
Evaporator Refrigerant Pressure <i>psig/kPa</i>						
Saturated Evaporator Rfgt.Temp. <i>F or C</i>						
EXV Position <i>%</i>						
Evaporator Rfgt Liquid Level <i>inches/mm</i>						
	Compressor 1A Tab			Compressor 1B Tab		
Operating Mode						
Hours	Hrs/mins			Hrs/mins		
Starts						
	15 min	30 min	45 min	15 min	30 min	45 min
Phase A - B Voltage <i>volts</i>						
Average Line Current <i>%RLA</i>						
Line 1 current <i>amps</i>						
Line 2 current <i>amps</i>						
Line 3 current <i>amps</i>						
Line 1 current <i>%RLA</i>						
Line 2 current <i>%RLA</i>						
Line 3 current <i>%RLA</i>						
Evaporator Oil Return Solenoid	open / closed	open / closed	open / closed	open / closed	open / closed	open / closed
Supply Oil Temperature <i>F or C</i>						
Intermediate Oil Pressure <i>psig/kPa</i>						
Female Step solenoid	load / unload	load / unload	load / unload	load / unload	load / unload	load / unload
High Pressure Cutout switch	Good / Tripped	Good / Tripped	Good / Tripped	Good / Tripped	Good / Tripped	Good / Tripped
Comments:						



Periodic Maintenance

	Compressor 2A Tab			Compressor 2B Tab		
Operating Mode						
Hours	Hrs/mins			Hrs/mins		
Starts						
	15 min	30 min	45 min	15 min	30 min	45 min
Phase A - B Voltage <i>volts</i>						
Average Line Current <i>%RLA</i>						
Line 1 current <i>amps</i>						
Line 2 current <i>amps</i>						
Line 3 current <i>amps</i>						
Line 1 current <i>%RLA</i>						
Line 2 current <i>%RLA</i>						
Line 3 current <i>%RLA</i>						
Evaporator Oil Return Solenoid	open / closed	open / closed	open / closed	open / closed	open / closed	open / closed
Supply Oil Temperature <i>F or C</i>						
Intermediate Oil Pressure <i>psig/kPa</i>						
Female Step solenoid	load / unload	load / unload	load / unload	load / unload	load / unload	load / unload
High Pressure Cutout switch	Good / Tripped	Good / Tripped	Good / Tripped	Good / Tripped	Good / Tripped	Good / Tripped
Comments:						

XI-Maintenance Procedures

Refrigerant and Oil Charge Management

Proper oil and refrigerant charge is essential for proper unit operation, unit performance, and environmental protection. Only trained and licensed service personnel should service the chiller.

Some symptoms of a refrigerant under-charged unit:

- Low subcooling
- Higher than normal discharge superheat
- Bubbles in EXV sight glass
- Low liquid level diagnostic
- Larger than normal evaporator approach temperatures (leaving water temperature - saturated evaporator temperature)
- Low evaporator refrigerant temperature limit
- Low refrigerant temperature cutout diagnostic
- Fully open expansion valve
- Possible whistling sound coming from liquid line (due to high vapor velocity)
- High condenser + subcooler pressure drop

Some symptoms of a refrigerant over-charged unit:

- High subcooling
- Evaporator liquid level higher than centerline after shut down
- Larger than normal condenser approach temperatures (entering condenser saturated temperature – entering air temperature)
- Condenser pressure limit
- High pressure cutout diagnostic
- More than normal number of fans running
- Erratic fan control
- Higher than normal compressor power
- Very low discharge superheat at startup
- Compressor rattle or grinding sound at startup

Some symptoms of an oil over-charged unit:

- Larger than normal evaporator approach temperatures (leaving water temperature - saturated evaporator temperature)
- Low evaporator refrigerant temperature limit
- Erratic liquid level control
- Low unit capacity
- Low discharge superheat (especially at high loads)
- Low liquid level diagnostics
- High oil sump level after normal shut

down

Some symptoms of an oil under-charged unit:

- Compressor rattle or grinding sound
- Lower than normal pressure drop through oil system
- Seized or welded compressors
- Low oil sump level after normal shut down
- Lower than normal oil concentrations in evaporator

R134a Field Charging Procedure

Be certain that the electrical power to the unit is disconnected before performing this procedure.

WARNING

Hazardous Voltage w/Capacitors!

Disconnect all electric power, including remote disconnects before servicing. Follow proper lockout/tagout procedures to ensure the power cannot be inadvertently energized. For variable frequency drives or other energy storing components provided by Trane or others, refer to the appropriate manufacturer's literature for allowable waiting periods for discharge of capacitors. Verify with an appropriate voltmeter that all capacitors have discharged. Failure to disconnect power and discharge capacitors before servicing could result in death or serious injury.

Note: For additional information regarding the safe discharge of capacitors.

Factory (initial) Refrigerant Charging Procedure

The initial charging procedure should be followed the first time the unit is charged in the factory, as well as for charging any time after the charge has been completely removed from the entire system in the event of repair.

1. As part of automatic vacuum/charge procedure, verify that the EXVs are OPEN.
2. Attach vacuum hoses to evaporator service valves (one per circuit). Open service valves.
3. Attach charging hoses to the charging port on the liquid line filter (one per circuit).

The filters contain a port with a ¼" (6mm) flare.

Maintenance Procedures

4. Begin semi-automatic vacuum procedure.
5. When vacuum is complete (indicated), manually isolate the unit from vacuum.
6. Charge unit through the filter housing port per Tables.
7. When charging is complete, shut evaporator service valve and disconnect vacuum and charging hoses.

Field Refrigerant Charging Procedure

Follow this procedure when the unit is empty of all refrigerant and under a vacuum.

Add the charge through the evaporator service valve.

CAUTION

Evaporator Damage!

Water must be flowing through the evaporator during the entire charging process to avoid freezing and rupturing of the evaporator tubes. Charge first with vapor to avoid freezing tubes.

1. Note the weight of the amount of charge removed. Compare it to Table - Table A difference in charge may indicate a leak.
2. Attach charging hose to evaporator service valve (3/8" (9mm) flare). Open service valve.
3. Add charge to evaporator to bring total circuit charge up to the level indicated in the above chart.
4. Close service valve and disconnect charging hose.

Adding charge:

This procedure should be followed when adding charge to an undercharged unit. When low charge is indicated by low subcooling in the liquid line, charge should be added until sufficient subcooling is achieved.

1. Attach charging hose to evaporator service valve (3/8" (9mm) flare). Open service valve.
2. Add 10 pounds of refrigerant (R-134a) charge.
3. Close valve, remove charging hose and start unit. Monitor subcooling.

4. If subcooling is still insufficient, return to step #1.

NOTE: Proper subcooling can be determined from run log history, service experience, or by contacting Trane technical service.

Charge Isolation in the high or low side of system

All the refrigerant may be trapped into the high side (condenser) of the unit for maintenance on the compressor or low side. With the suction line service valve option, charge may also be isolated in the evaporator for maintenance on the compressor or the high side. It is preferable to isolate the charge in the evaporator, if this option is available.

High side charge isolation procedure:

1. Make sure circuit is off.
2. Shut liquid line service valve.
3. Shut oil return line service valve.
4. Start circuit with the service tool in charge isolation mode:
 - All fans will turn on
 - EXV will open 100%
 - Oil return line solenoid (if included) will open
 - Unit will start at minimum load
 - Unit will run until it cuts out on low pressure (~6 psia) (0.41 bar)
 - Monitor pressure with a suction gauge
5. When unit trips, the discharge check valve will close.
6. Close discharge isolation valve.
7. Close oil line shut off valve.
8. Remove the remainder of the charge with transfer pump.

NOTE: Recommendation: Do not pump remaining charge into high side. This may introduce non condensable gasses and other contaminants into the unit.

9. The low side and compressor may be serviced at this time.



Maintenance Procedures

Tab. XI-01 – Charge Holding Capabilities on High Side

Nominal Capacity	Nominal Circuit Charge lb	Condenser Charge Holding Capacity @ 60% full 90° ambient lb	Charge in Oil Separator lb	% Oil Separator Level
70	165	118.1	46.9	97.7
85	175	134.3	40.7	86.0
100	215	163.7	51.3	56.0
120	225	187.9	37.1	41.2
170	365	203.4	161.6	100.0%
200	415	282.0	133	86.1 %
240	460	325.6	134.4	86.9 %

Circuit varies slightly with efficiency and unit configuration

NOTE: Units with a design sequence of A0 did not have enough capacity in the condenser to hold the entire charge. Table lists the amount of charge that would flood the oil separator if the charge was isolated in the high side. For this reason, when getting the unit back to running condition, care must be taken to drive the refrigerant out of the oil separator using the oil separator heaters.

Returning unit to running condition:

1. Open all valves.
2. Manually open EXV for 15 minutes to allow refrigerant to drain to evaporator by gravity (ensure water is flowing in the evaporator prior to opening the EXV).
3. Let unit sit with heaters on to drive refrigerant out of oil and warm up compressor bearings. Depending upon ambient conditions, this may take up to 24 hours. Ensure the UCM is powered so the pump may be energized if it detects a freeze condition.
4. Once the oil level has returned to normal, the unit can be put back into operation.

Low side charge isolation procedure:

After normal shut down under some conditions most of the charge resides in the evaporator. Running cold water through the evaporator may also drive much of the refrigerant to the evaporator.

1. Make sure circuit is off.
2. Close suction line isolation valve.
3. Close oil return line service valve.
4. Close liquid line service valve.

5. Manually open EXV.

6. Use a liquid pump or vacuum pump to move refrigerant from the condenser to evaporator. The liquid pump will only be effective if there is a lot of charge in the condenser. It may be connected to the condenser drain port on the liquid line isolation valve.

NOTE: If a pump is to be used, connect it before closing this valve. This port is only isolated when the valve is back seated.

If a vacuum pump is used, then connect it to the discharge line service valve near the oil separator. A vacuum pump will be required for part of the procedure.

Maintenance Procedures

The evaporator is large enough to hold all the charge for any unit to below the centerline of the shell. Therefore, no special precautions are required to restart the unit after isolating the charge in the evaporator.

Refrigerant Filter Replacement Procedure

A dirty filter is indicated by a temperature gradient across the filter, corresponding to a pressure drop. If the temperature downstream of the filter is 8°F (4.4°C) lower than the upstream temperature, the filter should be replaced. A temperature drop can also indicate that the unit is undercharged. Ensure proper subcooling before taking temperature readings.

1. With the unit off, verify that the EXV is closed. Close liquid line isolation valve. On units with remote evaporators or oil cooling circuits, close ball valve on oil cooler liquid line.

2. Attach hose to service port on liquid line filter flange.

3. Evacuate refrigerant from liquid line and store.

4. Remove hose.

5. Depress schrader valve to equalize pressure in liquid line with atmospheric pressure.

6. Remove bolts that retain filter flange.

7. Remove old filter element.

8. Inspect replacement filter element and lubricate o-ring with Trane OIL00048.

NOTE: Do not use mineral oil. It will contaminate the system.

9. Install new filter element in filter housing.

10. Inspect flange gasket and replace if damaged.

11. Install flange and torque bolts to 14-16 lb-ft (19-22 n-m).

12. Attach vacuum hose and evacuate liquid line.

13. Remove vacuum hose from liquid line and attach charging hose.

14. Replace stored charge in liquid line.

15. Remove charging hose.

16. Open liquid line isolation valve. On units with remote evaporators or oil cooler circuits, open oil cooler liquid line ball valve.

Lubrication System

The lubrication system has been designed to keep most of the oil lines filled with oil as long as there is a proper oil level in the oil sump.

The total oil charge can be removed by draining the oil system, oil return line from the evaporator, the evaporator, and the compressor. Very small quantities of oil may be found in other components.

Like many machines, an excessive oil charge can cause operational problems. Special care should always be taken to avoid adding extra oil.

Units that exhibit the symptoms of an oil overcharge at high loads may still run fine at light loads. An oil overcharged unit may result in an evaporator limit warning or even a low liquid level or low evap temp (LRTC) diagnostic. An oil overcharged unit may exhibit increased approach temperatures and decreased overall unit efficiency.

Oil Charging Procedure

Proper charging of the oil system is critical to the reliability of the compressor and chiller. Too little oil can cause the compressor to run hot and inefficient. When taken to an extreme, low oil level may result in instant failure of the compressor. Too much oil

will result in high oil circulation rates which will foul the condenser and evaporator performance. This will result in inefficient operation of the chiller. Taken to an extreme, high oil levels may result in erratic expansion valve control or shut down of the chiller due to low evaporator refrigerant temperature.

Too much oil may contribute to long term bearing wear. Additionally, excessive compressor wear is probable when the compressor is started with the oil lines dry.

Maintenance Procedures

Fig. XI-01 – Oil System Schematic

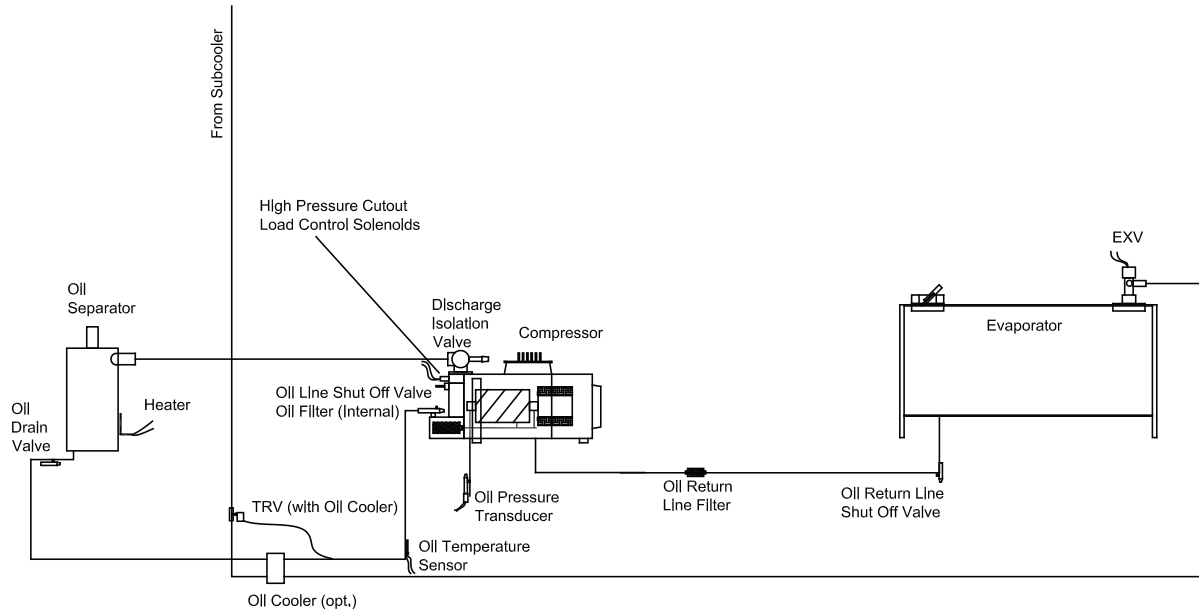

Oil system consists of the following components:

- Compressor
- Oil separator
- Discharge line with service valve
- Oil line from separator to compressor
- Oil line drain (lowest point in system)
- Oil cooler - optional
- Oil temperature sensor
- Oil line shut off valve with flare service connection

- Oil filter (internal to compressor) with flare fitting service connection and schrader valve
- Oil flow control valve (internal to the compressor after the filter)
- Oil return line from evaporator with shut off valve and strainer

Refer to Table below - Table for the standard oil charge for each circuit.

NOTE: Recommendation: check the oil level in the sump using a sight glass or a manometer, attached to charging hoses.

Tab. XI-02 – Charge Holding Capabilities on High Side

Circuit	Approximate sump oil level after	Normal quantity of oil in refrigeration
70	7	1.1 (0.14)
85	6	1.1 (0.14)
100	7	1.8 (0.23)
120	7	1.8 (0.23)
170	8	3.5 (0.44)
200	8	3.5 (0.44)
240	8	3.5 (0.44)

Circuit varies slightly with efficiency and unit configuration

Maintenance Procedures

- 1. To measure oil level, use the oil drain valve on the oil line and a service valve on the discharge line. This measurement can only be made when the circuit is not running.
- Note: The level is measured from the bottom of the separator and 1" must be subtracted for the thickness of the bottom plate.
- 2. The initial oil charge should be approximately at the level in the above chart. This is the approximate oil level if all the oil is in the oil lines, filter and oil sump and the unit is in vacuum so that there is no refrigerant dissolved in the oil.
- 3. After the unit has run for a while, the oil level in the sump can vary greatly. However, if the unit has run "normal" conditions for a long time the level should resemble the level in the above chart. (+1" to - 4" (25 to -101mm) is acceptable.)
- The field charging procedure depends on the circumstances that resulted in the need for oil charge.
 - 1. Some service procedures may result in loss of small quantities of oil which must be replaced (oil analysis, filter replacement, re-tubing the evaporator, etc.).
 - 2. Additionally, some maintenance procedures may result in virtually all of the oil being removed (compressor motor burn or total removal of the charge to trouble shoot a unit).
 - 3. Finally, leaks may result in a loss of oil that must be replaced.
- **Factory (initial) Oil Charging Procedure**
 - The initial charging procedure should be followed any time the unit is new or has had all of the oil removed.
 - 4. If the isolation valves is closed, then the charge may be trapped in the evaporator. In either case, the high side of the system should not be pressurized.
 - 5. The oil line shut off valve must be open to allow the oil to pass into the oil lines and the oil separator.
- 6. The oil charging port is a ¼" (6mm) flare fitting with a schrader valve that is on the side of the oil filter housing. This is the port that must be used to add oil into the compressor so that the filter and lines are full at the first start of the compressor.
- 7. On single compressor circuits all the oil should be put into the circuit through the oil charging port on the compressor filter housing. On two compressor circuits put approximately ½ of the oil into the unit through each of the two oil charging ports on the two compressors.
- 8. Oil may be put into the unit using either of two methods:
 - **CAUTION**
 - **Equipment Damage!**
 - **Use only Trane OIL00048 in the RTAC units to avoid any catastrophic damage to the compressor or unit.**
 - • Have the unit in vacuum. Note that the vacuum connection should be made on the unit at the service valve that is on the discharge line. Hook up the oil charging hose to the oil charging fitting and submerge the other end into the oil container. Let the vacuum draw the required amount of oil into the unit.
 - • Have the unit at the same pressure as the oil. Hook up the oil charging hose to the oil charging fitting and the other end to an oil pump. Use the pump to draw oil out of the oil container and push the required amount of oil into the unit.
- **NOTE:** The compressor filter has an internal shut off valve that will prevent oil from entering the compressor while the compressor is not running. Therefore, there is no concern about flooding the compressor with oil.



Maintenance Procedures

Field Oil Charging Procedure

Use the initial charging procedure under the following circumstances:

- When virtually all of the oil has been removed.
- If the oil charge is removed from the compressor and oil system only but the unit has been run for less than 15 minutes.
- If the oil charge is removed from the compressor and oil system only and the unit has been run for more than 15 minutes. However, reduce the amount of oil added to the unit by the normal quantity of oil in refrigeration system.

NOTE: This procedure can be followed even with the refrigerant charge isolated in the evaporating section of the unit.

If small quantities of oil were removed to service refrigeration components, such as the evaporator, simply replace the oil that was removed into the serviced component prior to vacuum and recharge of the refrigerant.

If oil was removed from the compressor only to service a compressor or change the oil filter follow this procedure:

1. If the compressor is a new compressor or has been removed from the system and reworked, add 1 quart (2 lb.) oil to the motor cavity prior to installing the compressor into the chiller.
2. Install the compressor in the system. Make sure that the filter shut off valve is closed. Other compressor isolation valves may also be closed depending upon the service that was completed. For example, changing the oil filter would require the compressor to be isolated and pulled into vacuum.

NOTE: Make sure that compressor is not pressurized.

3. Open the flare fitting on the oil line shut off valve.
4. Open the flare fitting on the filter housing. This is the port that must be used to put oil into the compressor.
5. Install charging hose on oil charging port (with schrader valve) and the other on the oil canister.
6. Lift the oil canister, or use a pump, to

pour oil into the filter housing.

7. When oil comes out of the flare fitting on the oil line shut off valve the filter is full. Stop adding oil.
8. Put the cap on the flare on the oil line shut off valve, remove the charging hose and put the cap back on the flare on the filter housing.
9. Vacuum the compressor (low side) and prepare it for inclusion in the system.

There is a service valve on the suction line and on the evaporator. Use these valves to vacuum the compressor.

10. Open the oil line shut off valve. Severe damage to the compressor can result if the oil line shut off valve is closed when the compressor is started.

CAUTION
Compressor Damage!
Catastrophic damage to the compressor will occur if the oil line shut off valve or the isolation valves are left closed on unit start-up.

11. Open the other compressor isolation valves.

NOTE: This procedure assumes that the oil that is put into the filter housing does not have contaminants such as non-condensable gases. The oil forces these gases out of the filter and oil line shut off valve without the need to pull a vacuum on this small volume. If the oil has been in an open container or is otherwise contaminated, then this small volume must be subject to vacuum as well. However, the filter cavity is full of oil. Therefore, be sure to use a flash tank in line with the vacuum pump to make sure that oil, that is pulled out of the filter cavity, does not slug the vacuum pump.

Evaporator tube replacement

The units were designed for installation of the tubes from the end of the evaporator opposite the control panel end.

The following units will need to have the circuit 2 control panel removed to replace tubes in the evaporator.

- 30' Base - 3 compressor units
- 36' Base - 3 compressor units

Maintenance Procedures

CAUTION

Evaporator Damage!

The tubes are rolled at both ends and in the center. When replacing tubes, take care to ensure that the tube is removed and rolled into the center tube sheet properly. Failure to do so could result in damage to the tubes and improper operation of the system.

Compressor Replacement

service valves, and trim charge as required.

If a compressor needs to be replaced follow the procedures listed below.

1. Isolate the refrigerant charge outside of the compressor and close all four valves leading to the compressor. This includes the oil line service valve located on the oil filter cover of the compressor, the valve on the oil return line from the evaporator, the discharge service valve, and the suction service valve. In the event that the optional suction service valve was not ordered with the unit, insure that the liquid line service valve is closed.

2. Disconnect power to the chiller. Remove the electrical junction box cover and disconnect the wires.

WARNING

Hazardous Voltage!

Disconnect all electric power, including remote disconnects before servicing. Follow proper lockout/tagout procedures to ensure the power can not be inadvertently energized. Failure to disconnect power before servicing could result in death or serious injury.

3. Evacuate the compressor through the service fitting provided. If the unit does not have suction service valves, this will include evacuating the low side of the system as well. Disconnect all four lines attached to the compressor, as well as the junction box. Remove three screws from the bottom of the compressor.

4. Remove the compressor by sliding it out of the chiller onto a well supported skid or other platform. The compressor is very heavy, so insure that the support is sturdy. A piece of 1x4 lumber placed between the isolators works well to support the compressor feet as it is pulled from the chiller.

5. Install the new compressor. Reinstall all lines, wires, and screws. Open the



XII-Wiring Diagram

Fig. XII-01 – Wiring Diagram, M&L, Y-D, Circuit 1

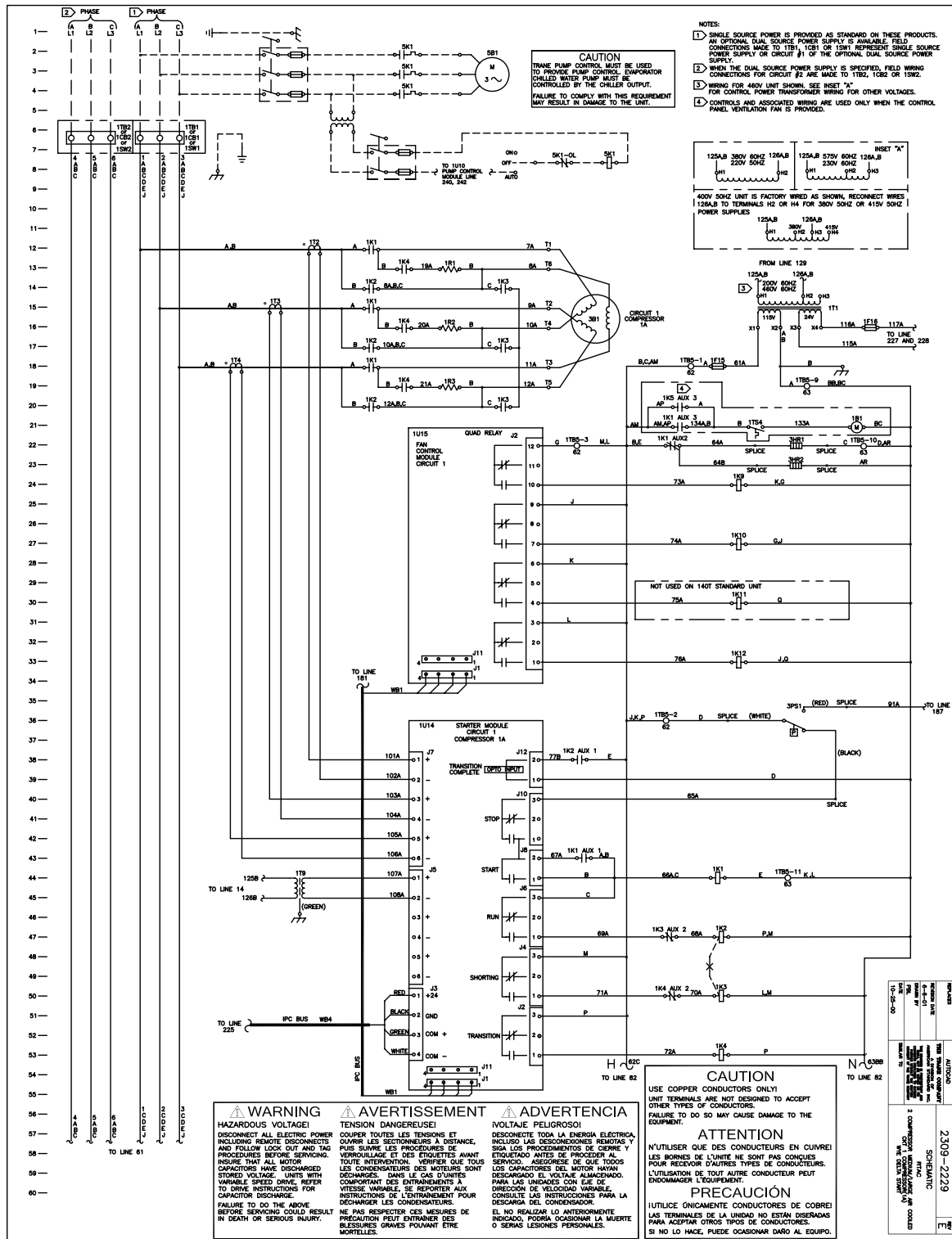

Wiring Diagram

Fig. XII-02 – Wiring Diagram, M&L, Y-D, Circuit 2

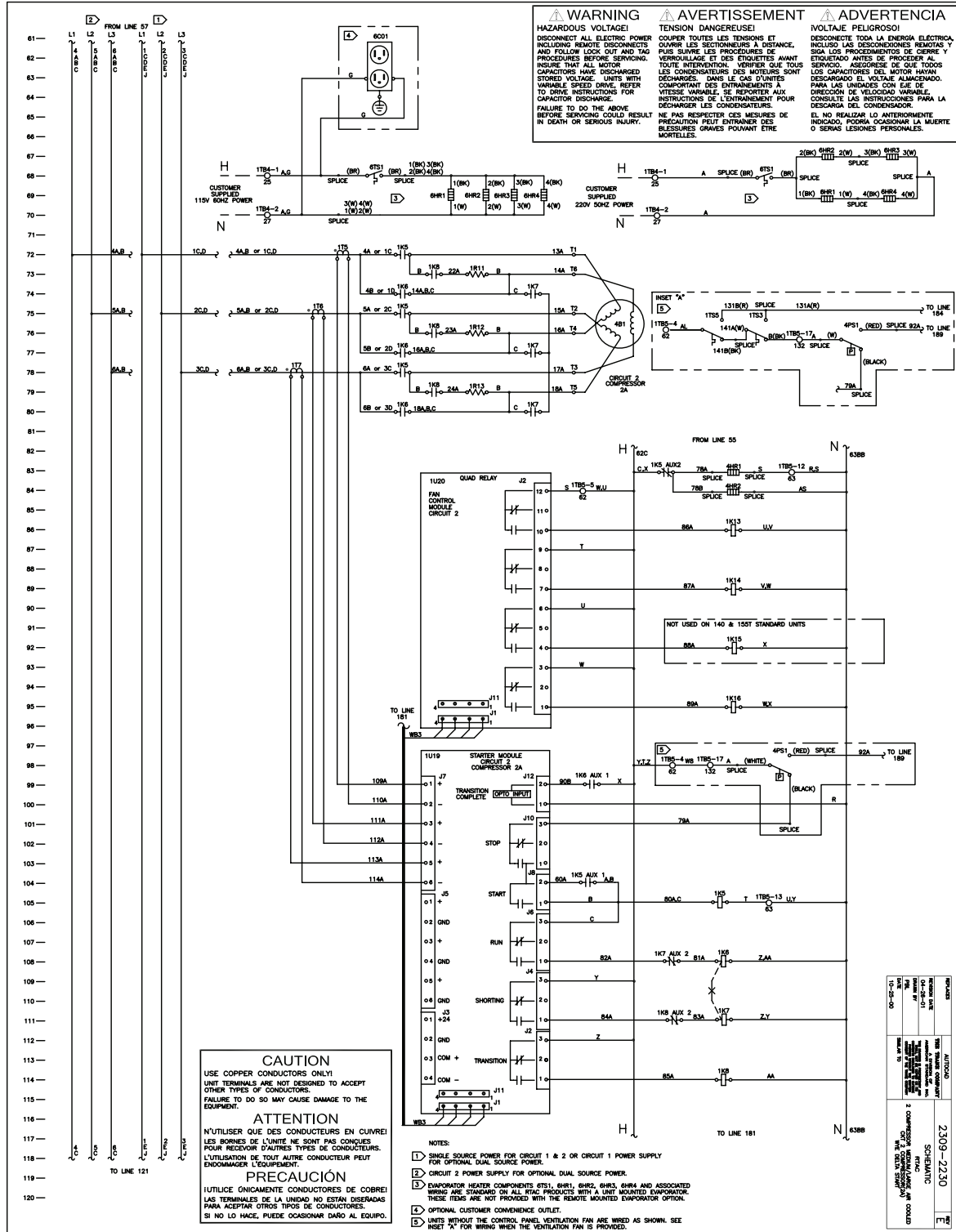

Wiring Diagram

Fig. XII-03 – Wiring Diagram, 3&4 Length, Length 1A, Y-D

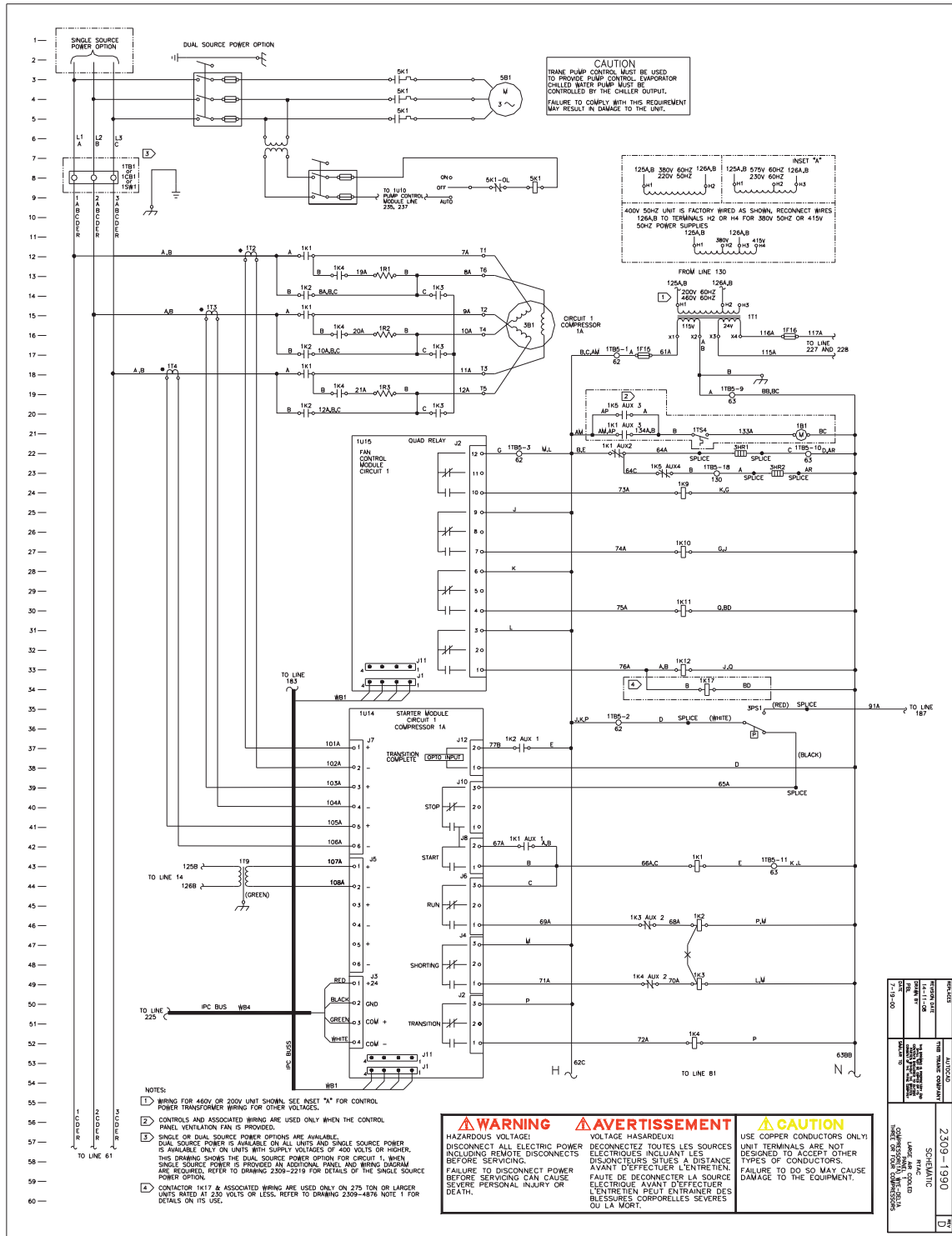

Wiring Diagram

Fig. XII-04 – Wiring Diagram, 3&4 Length, Length 1B, Y-D

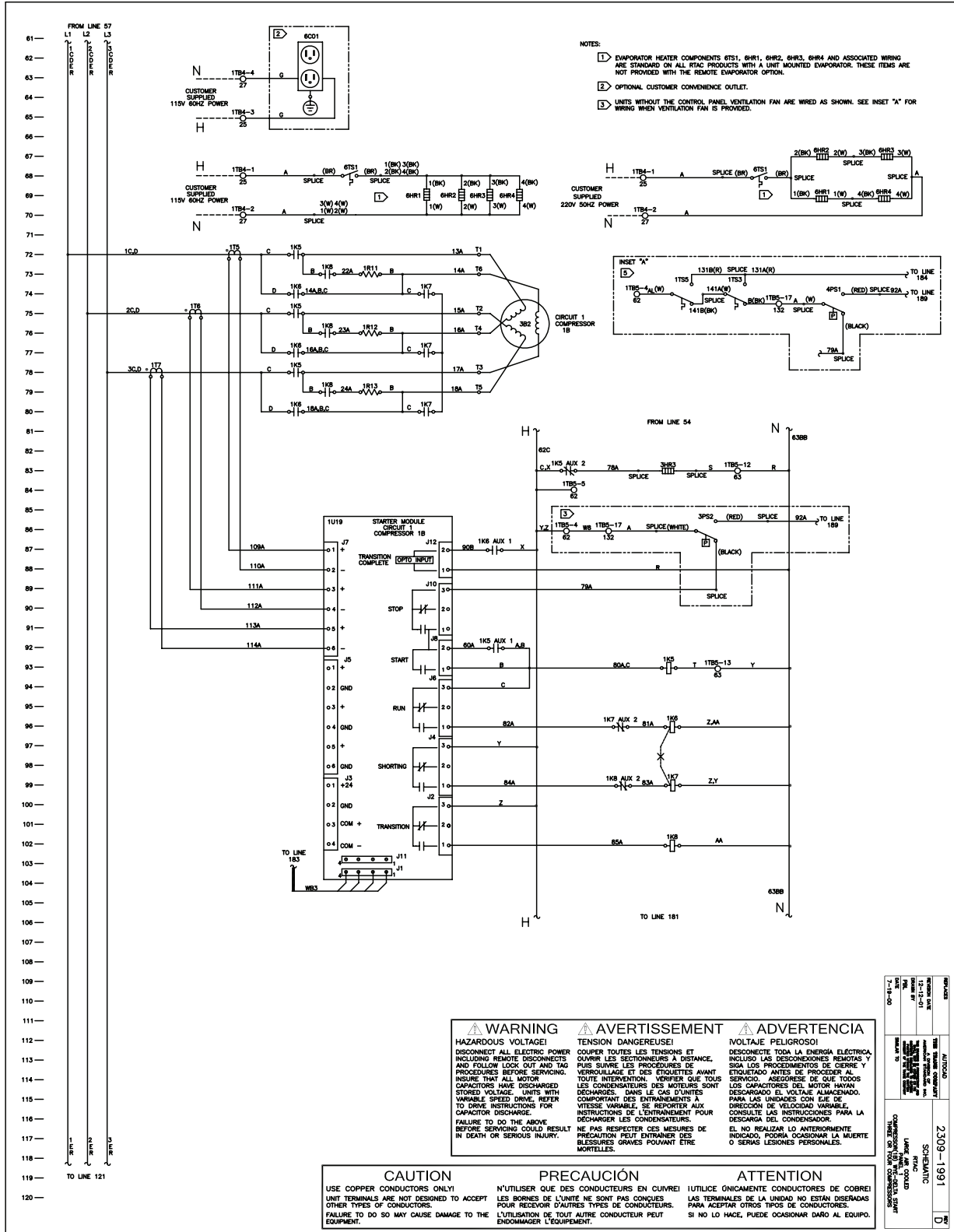

Wiring Diagram

Fig. XII-05 – Wiring Diagram, 3 Length, Length 2A, Y-D

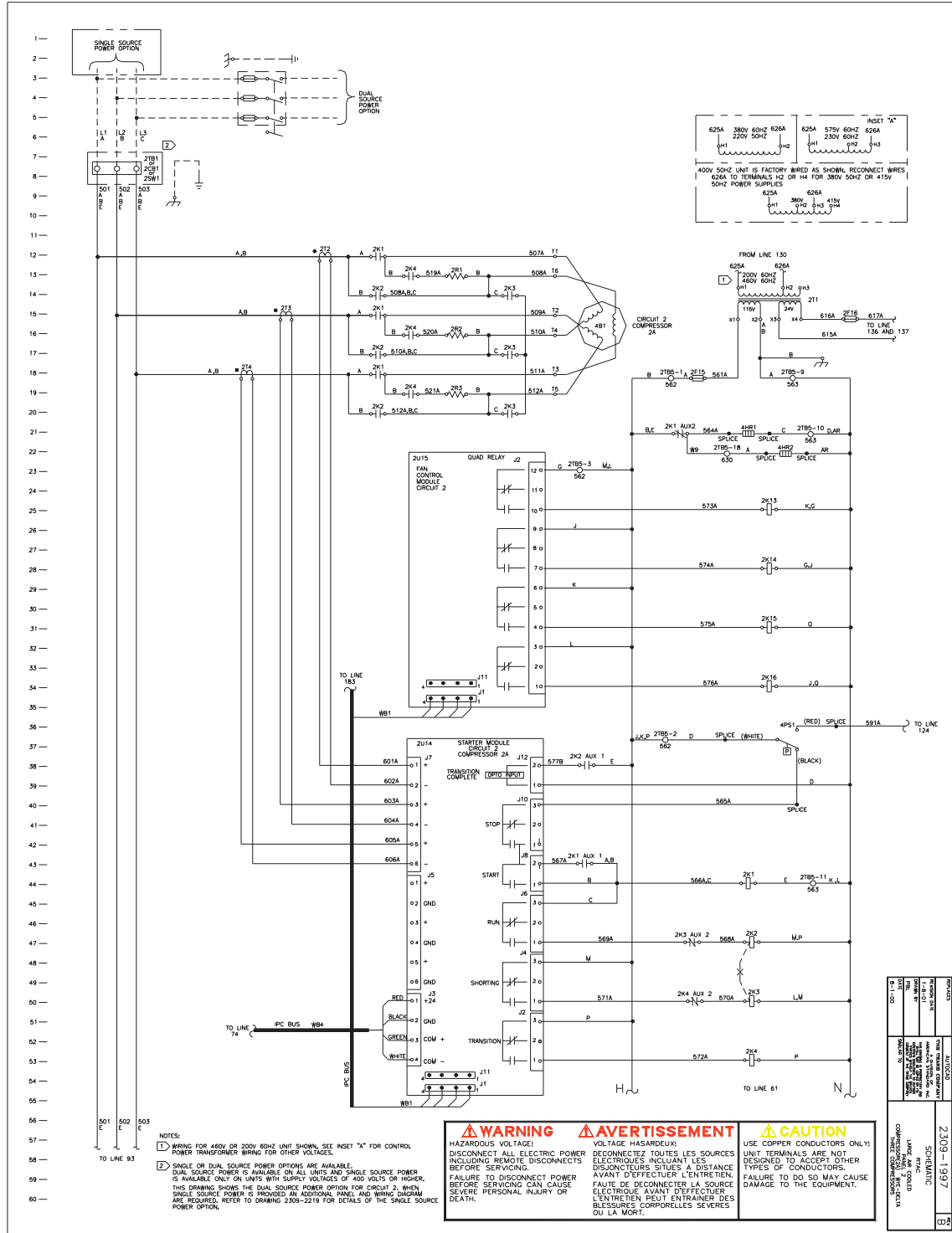

Wiring Diagram

Fig. XII-06 – Wiring Diagram, Fan, 3 Length, Length 2

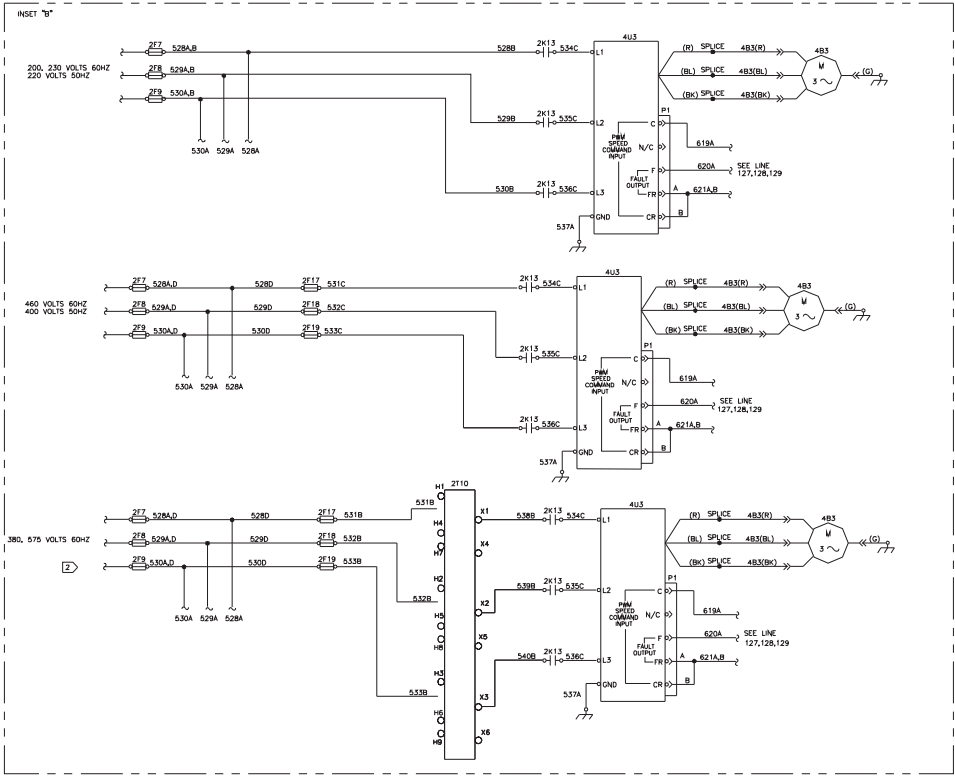
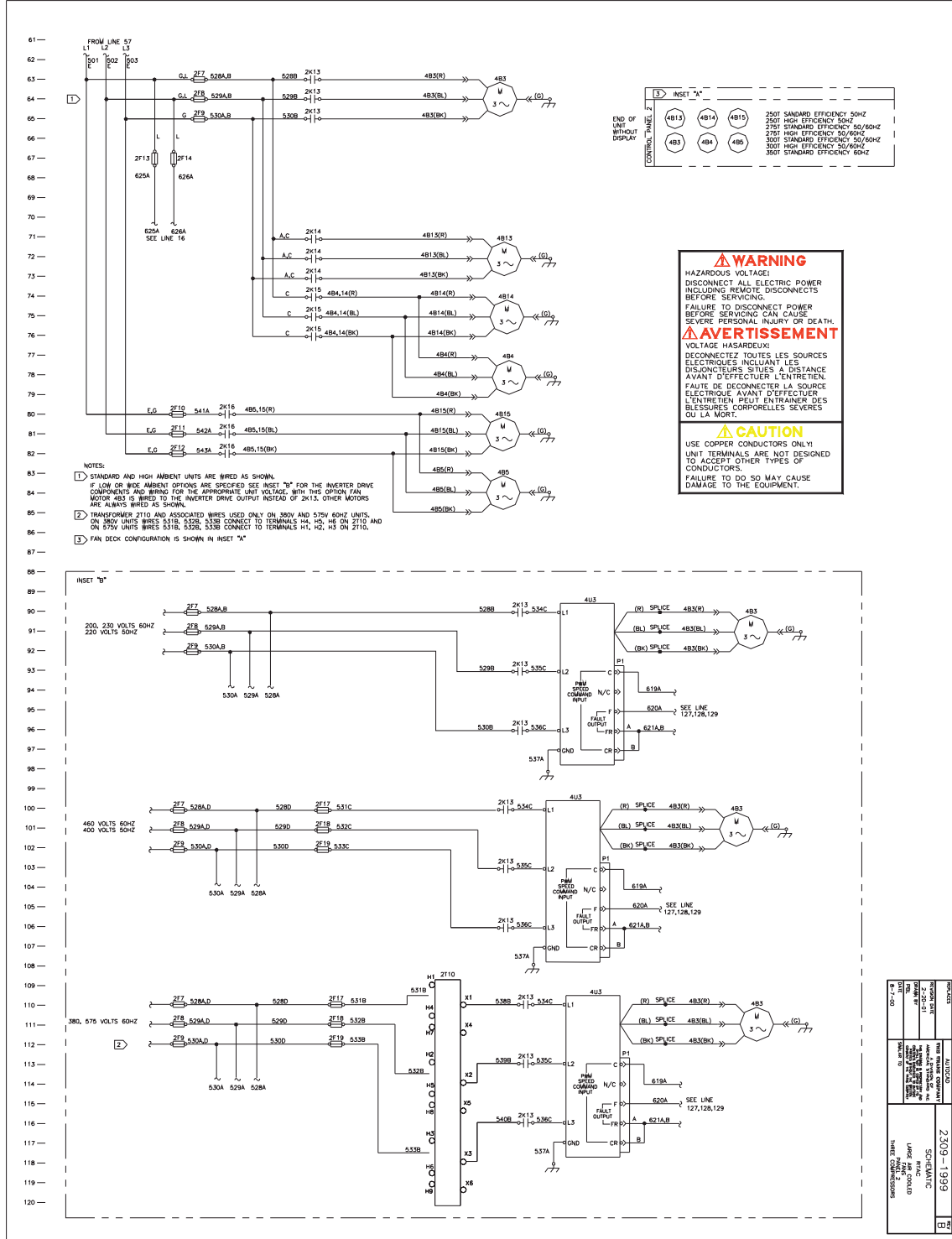

REVISIONS	DATE	BY	DESCRIPTION
1	2-20-11	AMC	REVISED FOR 2009-1999
2	1-11-11	AMC	REVISED FOR 2009-1999
3	1-11-11	AMC	REVISED FOR 2009-1999
4	1-11-11	AMC	REVISED FOR 2009-1999
5	1-11-11	AMC	REVISED FOR 2009-1999
6	1-11-11	AMC	REVISED FOR 2009-1999
7	1-11-11	AMC	REVISED FOR 2009-1999
8	1-11-11	AMC	REVISED FOR 2009-1999
9	1-11-11	AMC	REVISED FOR 2009-1999
10	1-11-11	AMC	REVISED FOR 2009-1999
11	1-11-11	AMC	REVISED FOR 2009-1999
12	1-11-11	AMC	REVISED FOR 2009-1999
13	1-11-11	AMC	REVISED FOR 2009-1999
14	1-11-11	AMC	REVISED FOR 2009-1999
15	1-11-11	AMC	REVISED FOR 2009-1999
16	1-11-11	AMC	REVISED FOR 2009-1999
17	1-11-11	AMC	REVISED FOR 2009-1999
18	1-11-11	AMC	REVISED FOR 2009-1999
19	1-11-11	AMC	REVISED FOR 2009-1999
20	1-11-11	AMC	REVISED FOR 2009-1999
21	1-11-11	AMC	REVISED FOR 2009-1999
22	1-11-11	AMC	REVISED FOR 2009-1999
23	1-11-11	AMC	REVISED FOR 2009-1999
24	1-11-11	AMC	REVISED FOR 2009-1999
25	1-11-11	AMC	REVISED FOR 2009-1999
26	1-11-11	AMC	REVISED FOR 2009-1999
27	1-11-11	AMC	REVISED FOR 2009-1999
28	1-11-11	AMC	REVISED FOR 2009-1999
29	1-11-11	AMC	REVISED FOR 2009-1999
30	1-11-11	AMC	REVISED FOR 2009-1999
31	1-11-11	AMC	REVISED FOR 2009-1999
32	1-11-11	AMC	REVISED FOR 2009-1999
33	1-11-11	AMC	REVISED FOR 2009-1999
34	1-11-11	AMC	REVISED FOR 2009-1999
35	1-11-11	AMC	REVISED FOR 2009-1999
36	1-11-11	AMC	REVISED FOR 2009-1999
37	1-11-11	AMC	REVISED FOR 2009-1999
38	1-11-11	AMC	REVISED FOR 2009-1999
39	1-11-11	AMC	REVISED FOR 2009-1999
40	1-11-11	AMC	REVISED FOR 2009-1999
41	1-11-11	AMC	REVISED FOR 2009-1999
42	1-11-11	AMC	REVISED FOR 2009-1999
43	1-11-11	AMC	REVISED FOR 2009-1999
44	1-11-11	AMC	REVISED FOR 2009-1999
45	1-11-11	AMC	REVISED FOR 2009-1999
46	1-11-11	AMC	REVISED FOR 2009-1999
47	1-11-11	AMC	REVISED FOR 2009-1999
48	1-11-11	AMC	REVISED FOR 2009-1999
49	1-11-11	AMC	REVISED FOR 2009-1999
50	1-11-11	AMC	REVISED FOR 2009-1999
51	1-11-11	AMC	REVISED FOR 2009-1999
52	1-11-11	AMC	REVISED FOR 2009-1999
53	1-11-11	AMC	REVISED FOR 2009-1999
54	1-11-11	AMC	REVISED FOR 2009-1999
55	1-11-11	AMC	REVISED FOR 2009-1999
56	1-11-11	AMC	REVISED FOR 2009-1999
57	1-11-11	AMC	REVISED FOR 2009-1999
58	1-11-11	AMC	REVISED FOR 2009-1999
59	1-11-11	AMC	REVISED FOR 2009-1999
60	1-11-11	AMC	REVISED FOR 2009-1999
61	1-11-11	AMC	REVISED FOR 2009-1999
62	1-11-11	AMC	REVISED FOR 2009-1999
63	1-11-11	AMC	REVISED FOR 2009-1999
64	1-11-11	AMC	REVISED FOR 2009-1999
65	1-11-11	AMC	REVISED FOR 2009-1999
66	1-11-11	AMC	REVISED FOR 2009-1999
67	1-11-11	AMC	REVISED FOR 2009-1999
68	1-11-11	AMC	REVISED FOR 2009-1999
69	1-11-11	AMC	REVISED FOR 2009-1999
70	1-11-11	AMC	REVISED FOR 2009-1999
71	1-11-11	AMC	REVISED FOR 2009-1999
72	1-11-11	AMC	REVISED FOR 2009-1999
73	1-11-11	AMC	REVISED FOR 2009-1999
74	1-11-11	AMC	REVISED FOR 2009-1999
75	1-11-11	AMC	REVISED FOR 2009-1999
76	1-11-11	AMC	REVISED FOR 2009-1999
77	1-11-11	AMC	REVISED FOR 2009-1999
78	1-11-11	AMC	REVISED FOR 2009-1999
79	1-11-11	AMC	REVISED FOR 2009-1999
80	1-11-11	AMC	REVISED FOR 2009-1999
81	1-11-11	AMC	REVISED FOR 2009-1999
82	1-11-11	AMC	REVISED FOR 2009-1999
83	1-11-11	AMC	REVISED FOR 2009-1999
84	1-11-11	AMC	REVISED FOR 2009-1999
85	1-11-11	AMC	REVISED FOR 2009-1999
86	1-11-11	AMC	REVISED FOR 2009-1999
87	1-11-11	AMC	REVISED FOR 2009-1999
88	1-11-11	AMC	REVISED FOR 2009-1999
89	1-11-11	AMC	REVISED FOR 2009-1999
90	1-11-11	AMC	REVISED FOR 2009-1999
91	1-11-11	AMC	REVISED FOR 2009-1999
92	1-11-11	AMC	REVISED FOR 2009-1999
93	1-11-11	AMC	REVISED FOR 2009-1999
94	1-11-11	AMC	REVISED FOR 2009-1999
95	1-11-11	AMC	REVISED FOR 2009-1999
96	1-11-11	AMC	REVISED FOR 2009-1999
97	1-11-11	AMC	REVISED FOR 2009-1999
98	1-11-11	AMC	REVISED FOR 2009-1999
99	1-11-11	AMC	REVISED FOR 2009-1999
100	1-11-11	AMC	REVISED FOR 2009-1999
101	1-11-11	AMC	REVISED FOR 2009-1999
102	1-11-11	AMC	REVISED FOR 2009-1999
103	1-11-11	AMC	REVISED FOR 2009-1999
104	1-11-11	AMC	REVISED FOR 2009-1999
105	1-11-11	AMC	REVISED FOR 2009-1999
106	1-11-11	AMC	REVISED FOR 2009-1999
107	1-11-11	AMC	REVISED FOR 2009-1999
108	1-11-11	AMC	REVISED FOR 2009-1999
109	1-11-11	AMC	REVISED FOR 2009-1999
110	1-11-11	AMC	REVISED FOR 2009-1999
111	1-11-11	AMC	REVISED FOR 2009-1999
112	1-11-11	AMC	REVISED FOR 2009-1999
113	1-11-11	AMC	REVISED FOR 2009-1999
114	1-11-11	AMC	REVISED FOR 2009-1999
115	1-11-11	AMC	REVISED FOR 2009-1999
116	1-11-11	AMC	REVISED FOR 2009-1999
117	1-11-11	AMC	REVISED FOR 2009-1999
118	1-11-11	AMC	REVISED FOR 2009-1999
119	1-11-11	AMC	REVISED FOR 2009-1999
120	1-11-11	AMC	REVISED FOR 2009-1999

Wiring Diagram

Fig. XII-07 – Wiring Diagram, Fan, Medium, 140&155 Std

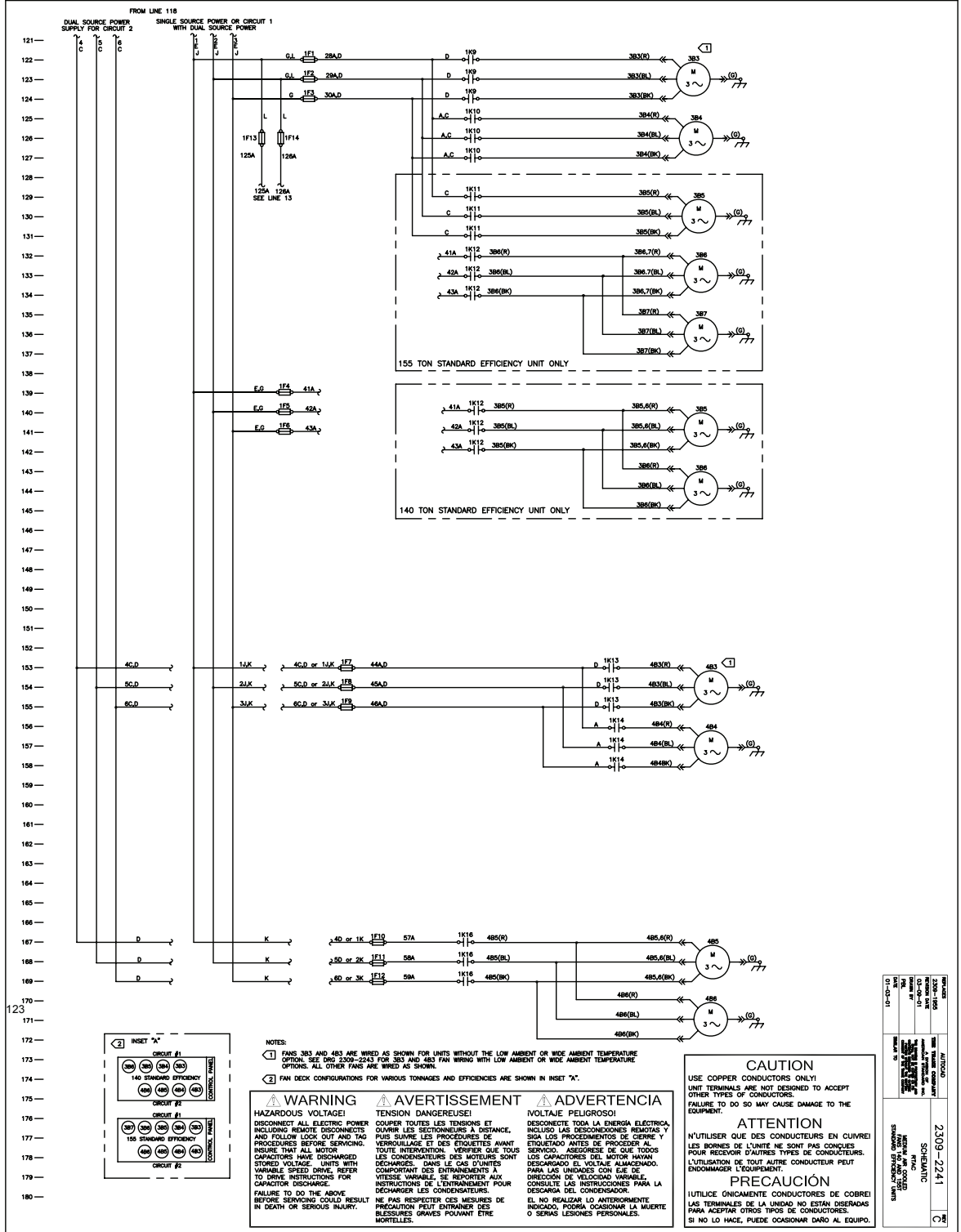

Wiring Diagram

Fig. XII-08 – Wiring Diagram, Fan, Medium, all others

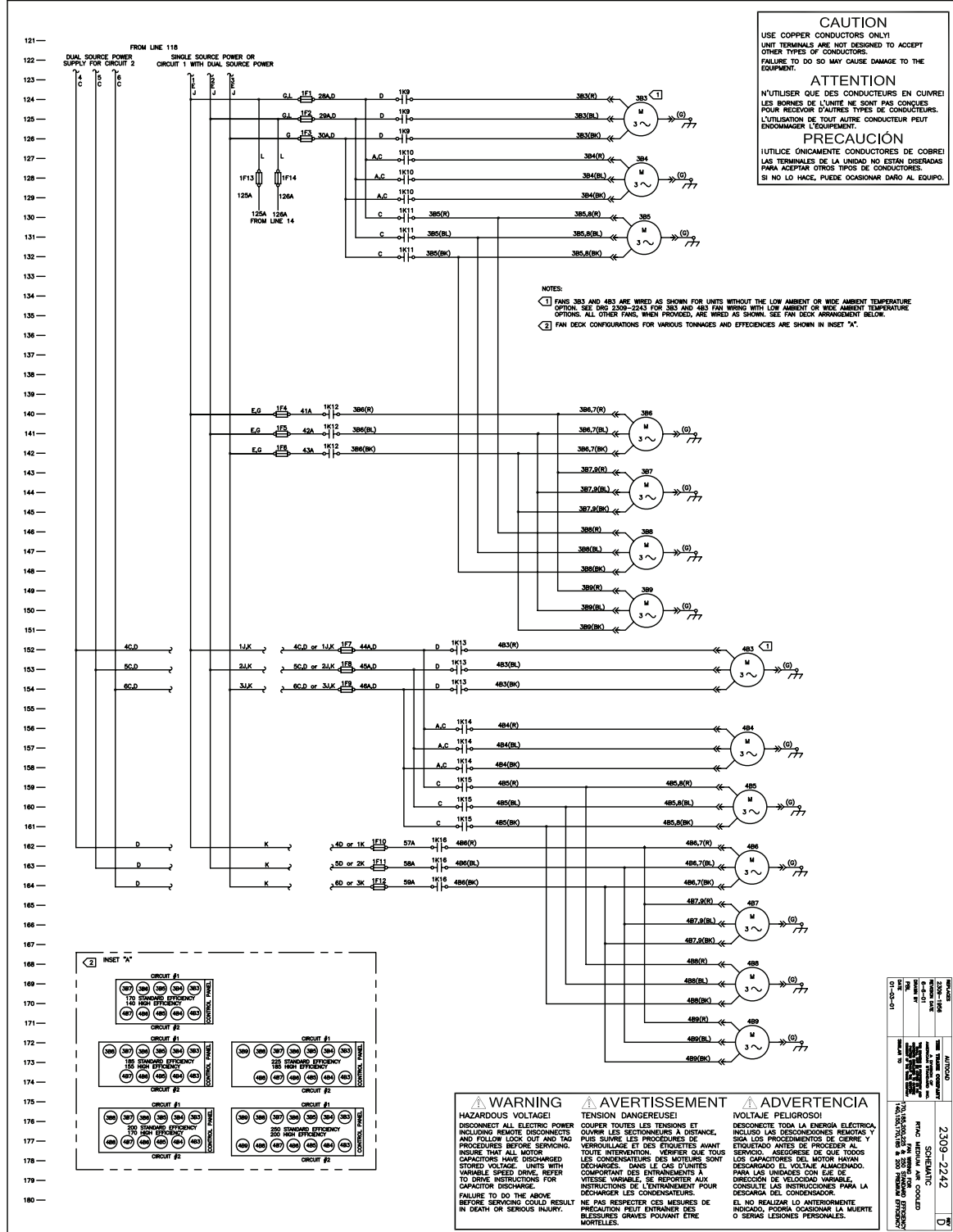

Wiring Diagram

Fig. XII-09 – Wiring Diagram, Fan, Big (225&250 Prem)

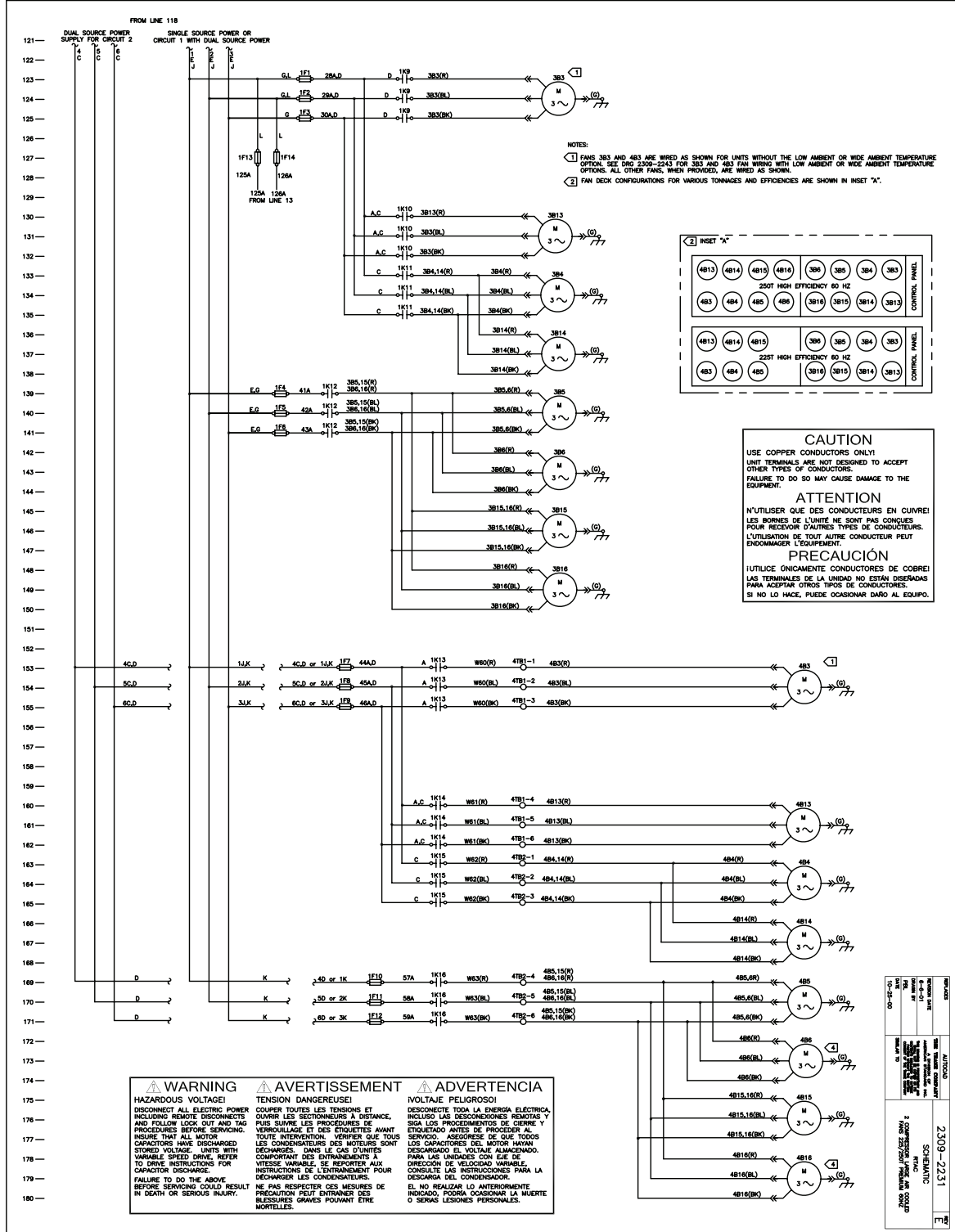

Wiring Diagram

Fig. XII-10 – Wiring Diagram, Fan, 3&4 Length, Circuit 1, Low Voltage

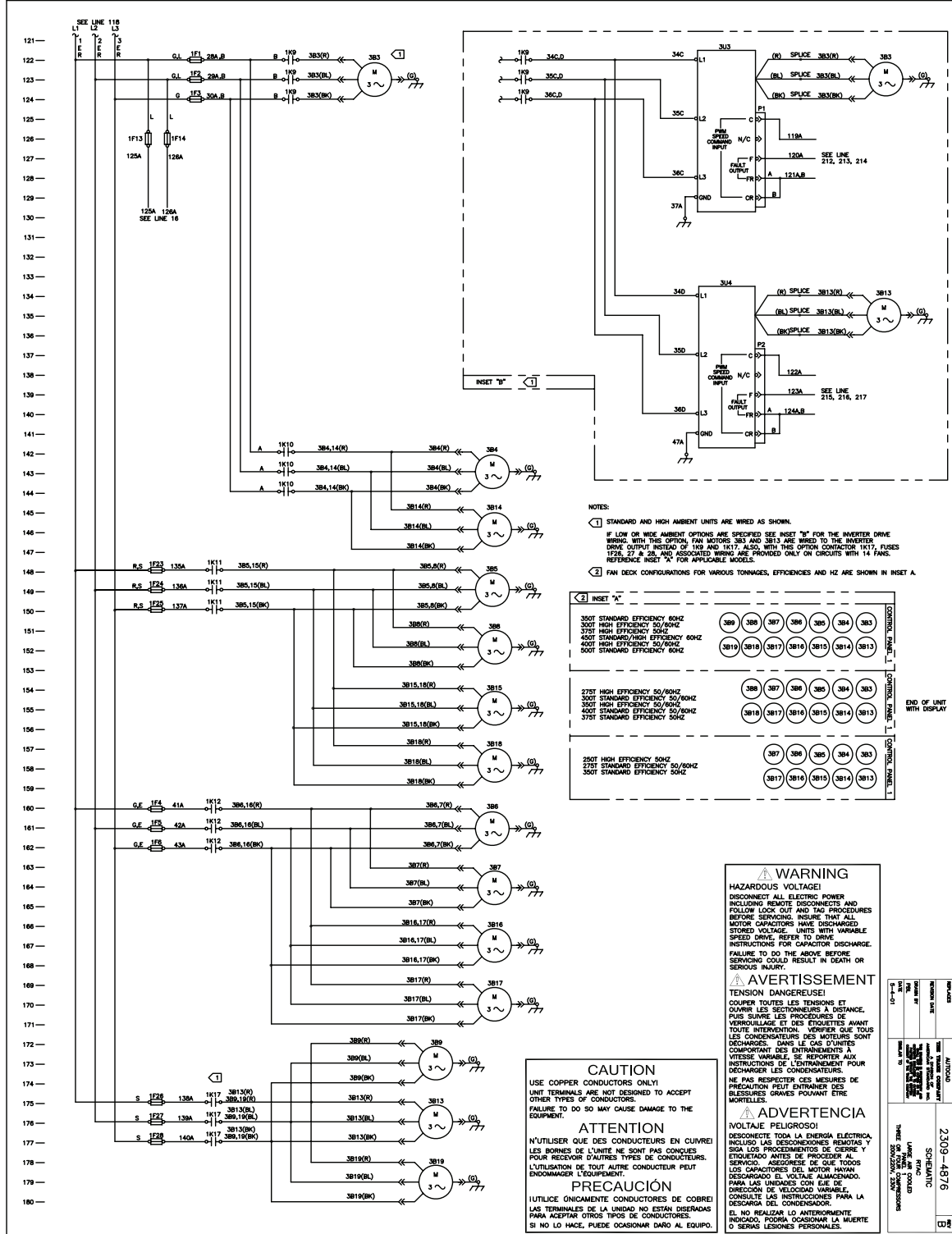

Wiring Diagram

Fig. XII-11 – Wiring Diagram, Fan, 3&4 Length, Circuit 1, Hight Voltage

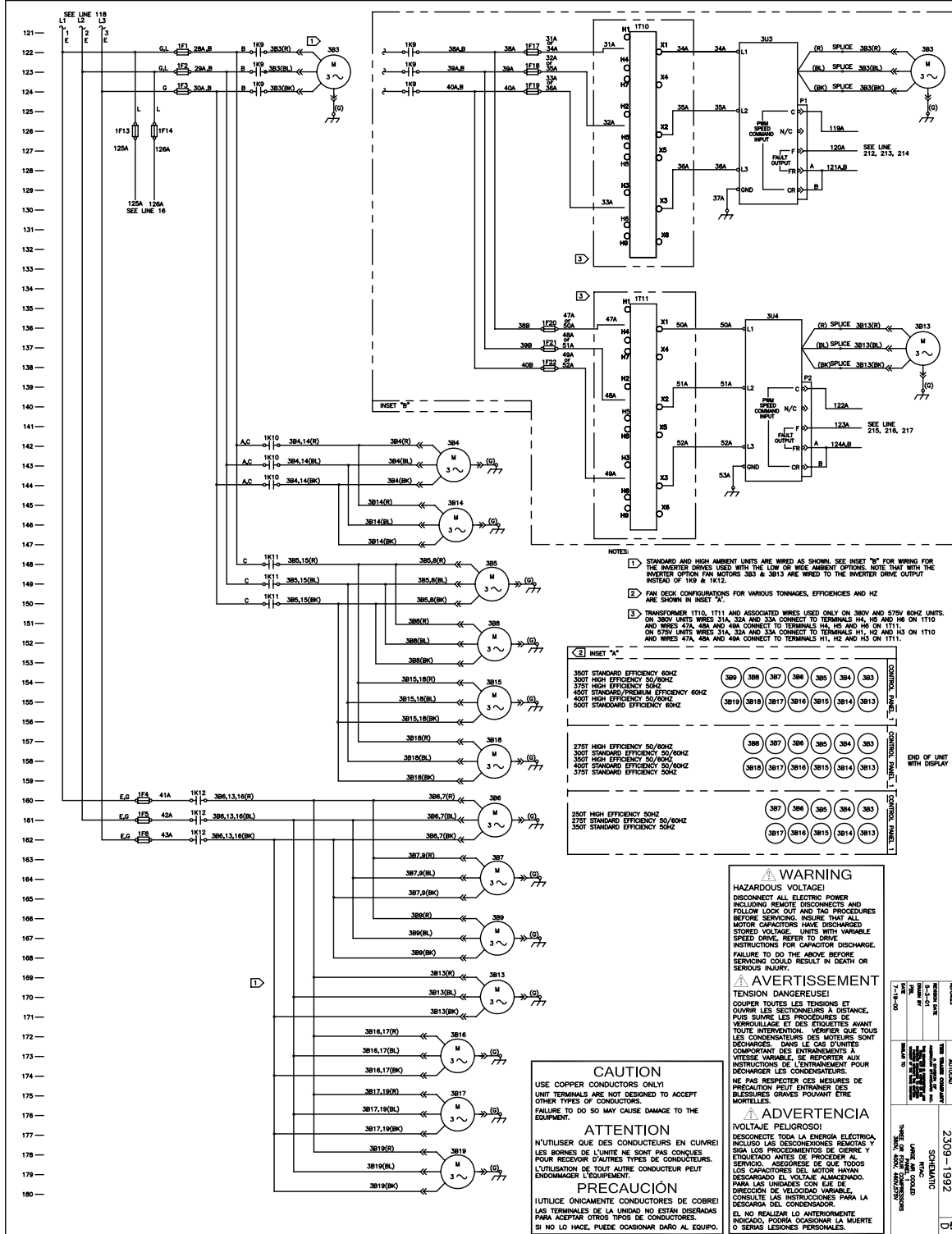

Wiring Diagram

Fig. XII-12 – Wiring Diagram, Fan, 3 Length, Circuit 1, 250T, 50Hz, Std

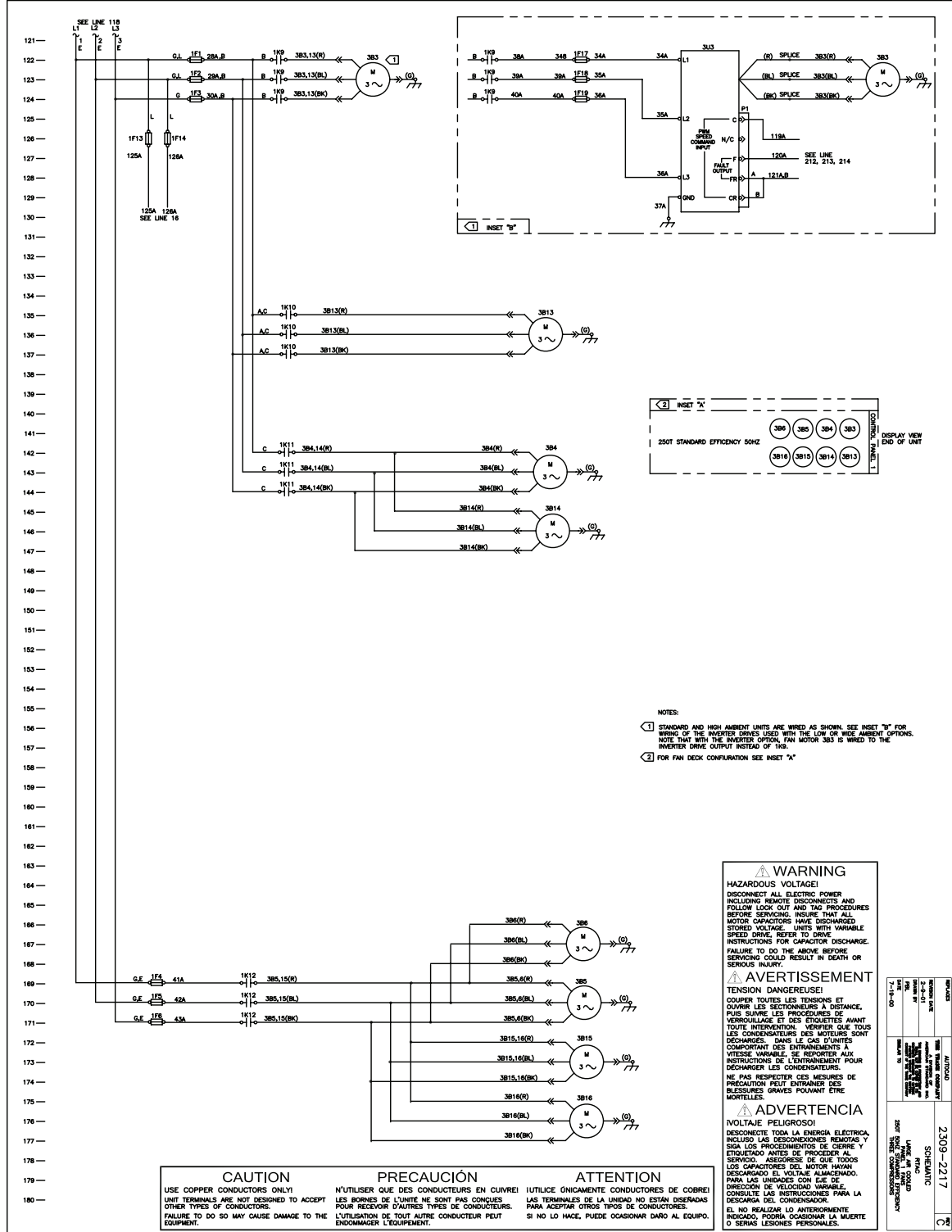

Wiring Diagram

Fig. XII-13 – Wiring Diagram, Control, M&L

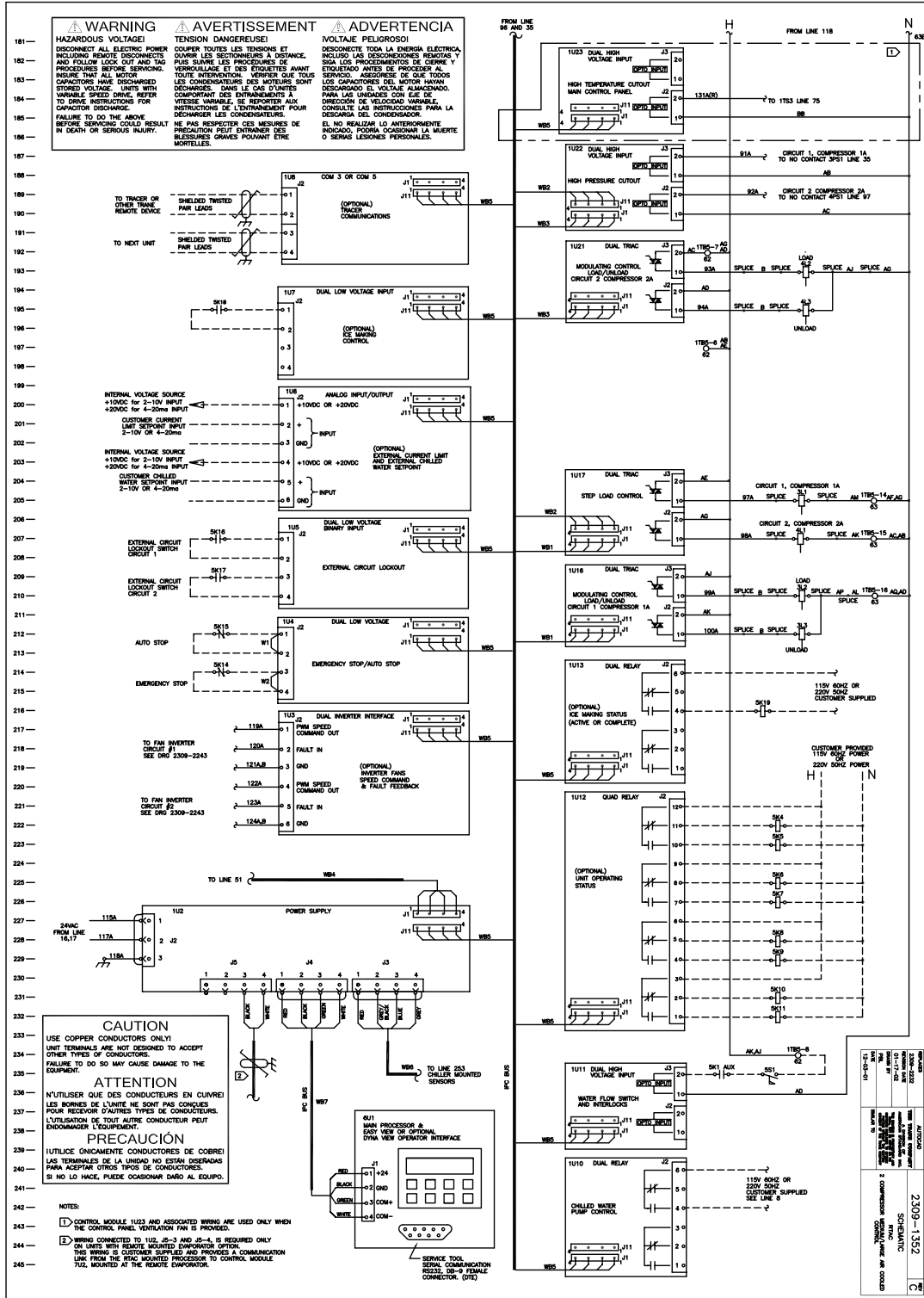

Wiring Diagram

Fig. XII-14 – Wiring Diagram, Controls, 3&4 Length, Circuit 1

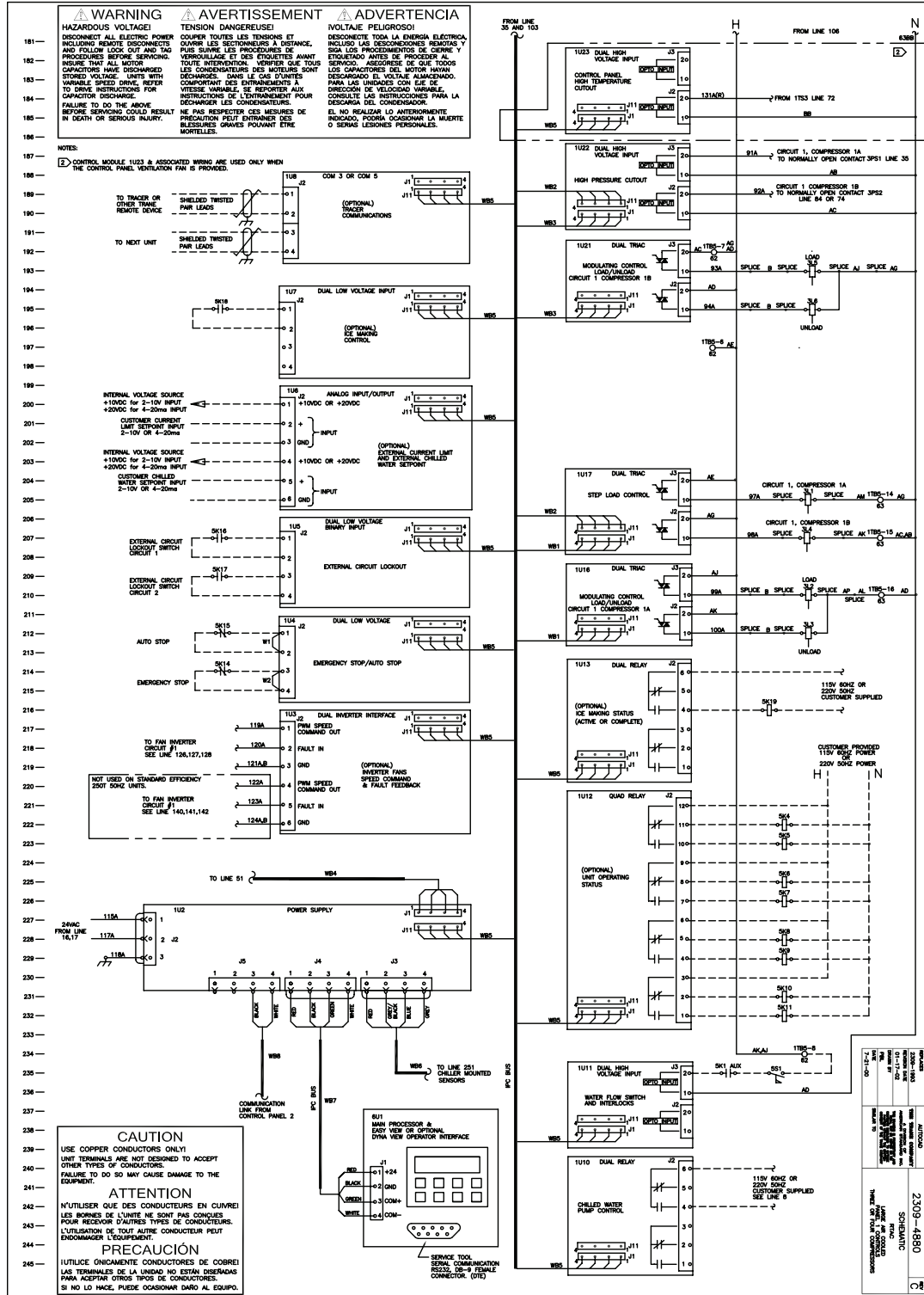

Wiring Diagram

Fig. XII-15 – Wiring Diagram, Controls/Legend/Bus, 3 Length, Circuit 2

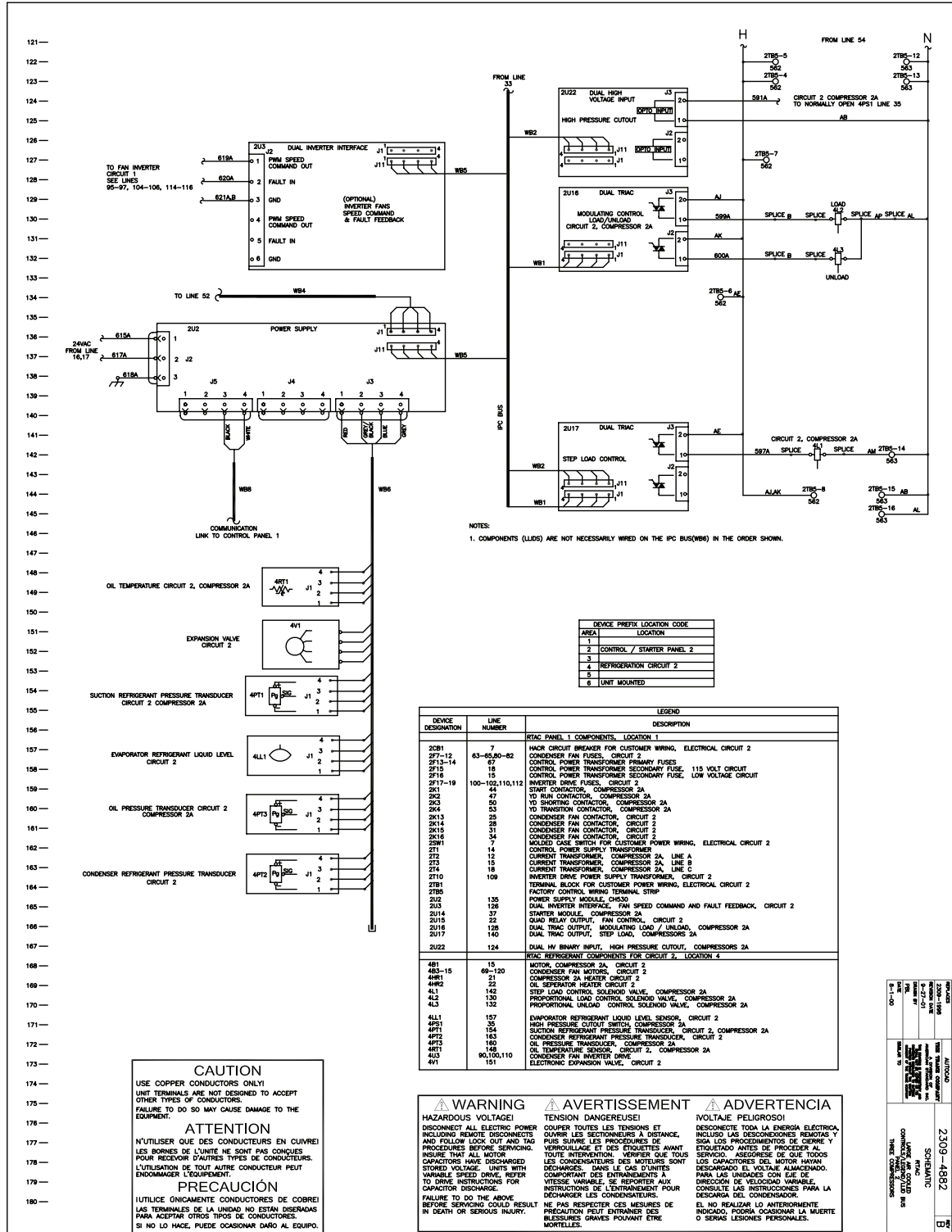

Wiring Diagram

Fig. XII-16 – Wiring Diagram, Legend/LLID Bus, M&L

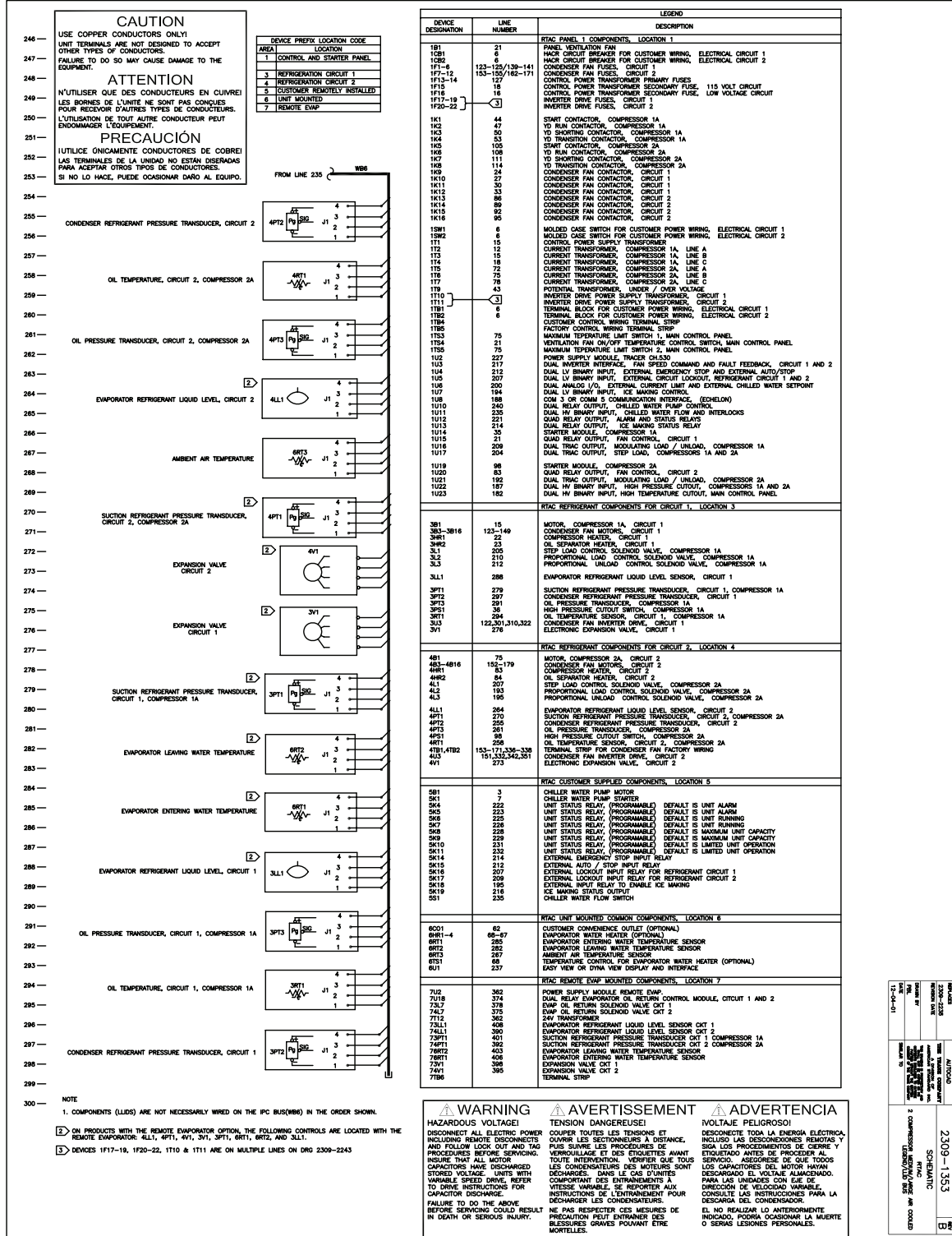

Wiring Diagram

Fig. XII-17 – Wiring Diagram, Legend/LLID Bus, 3&4 Length, Circuit1

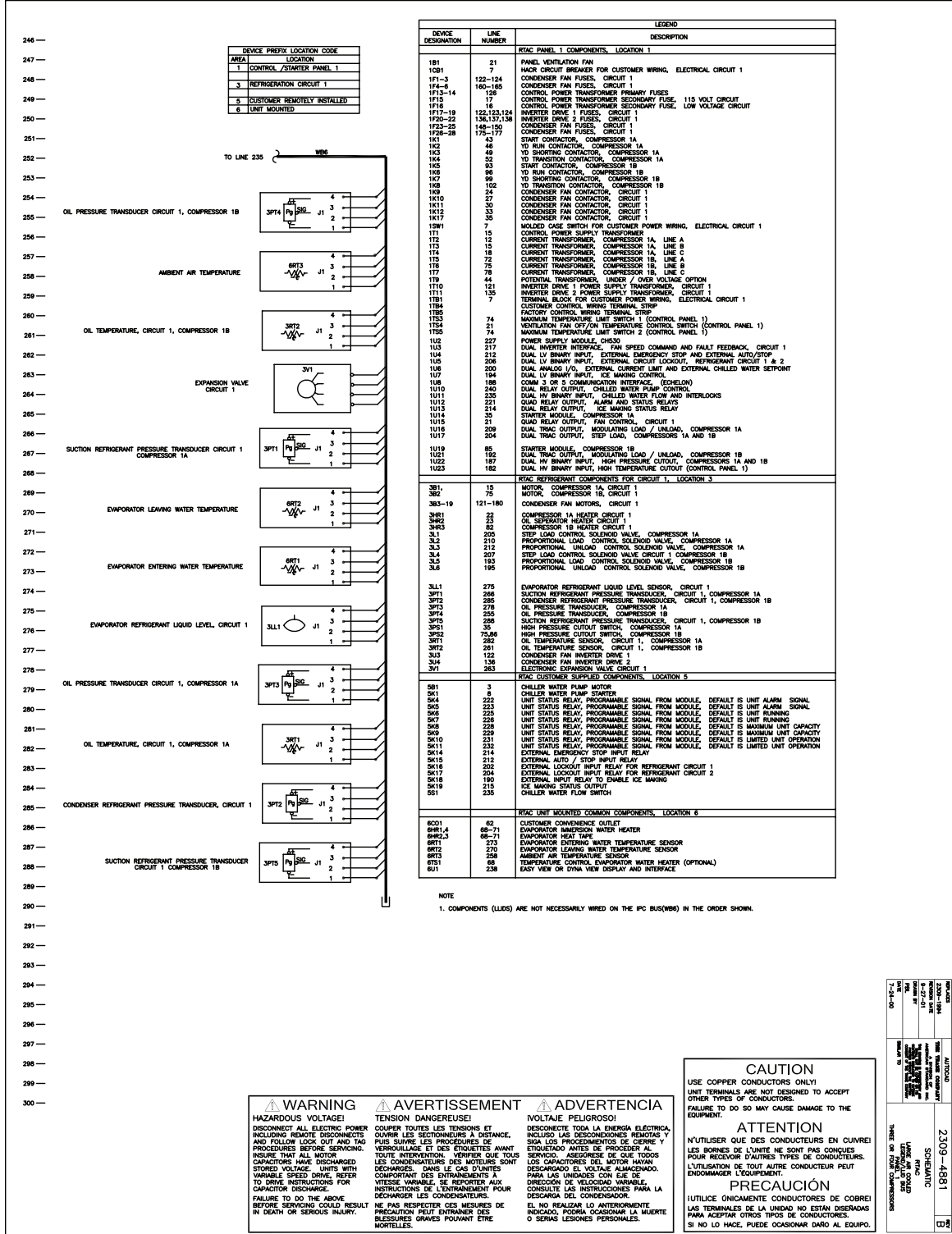

Wiring Diagram

Fig. XII-18 – Wiring Diagram, Fan, M&L, Inverters

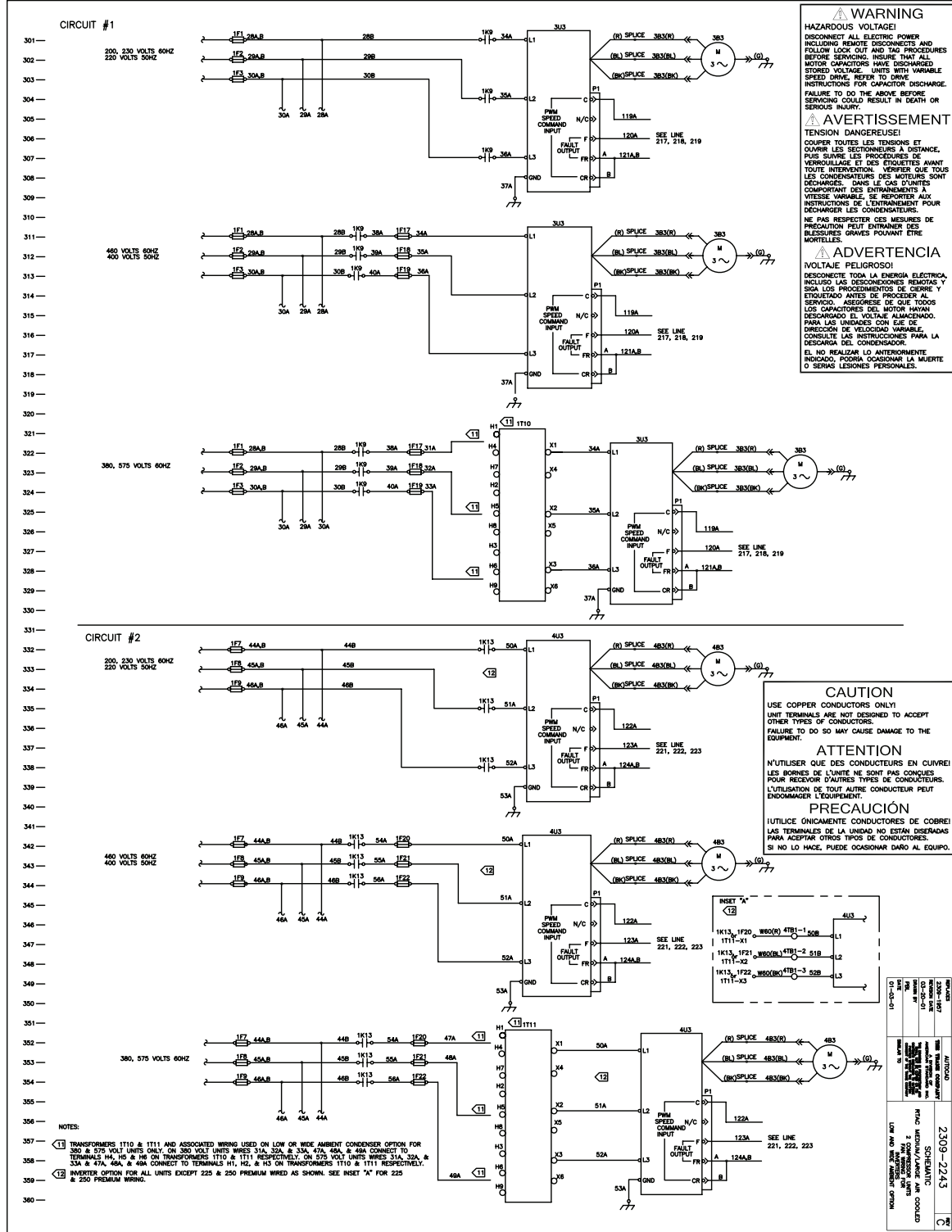

Wiring Diagram

Fig. XII-19 – Location of Component, 2 Length

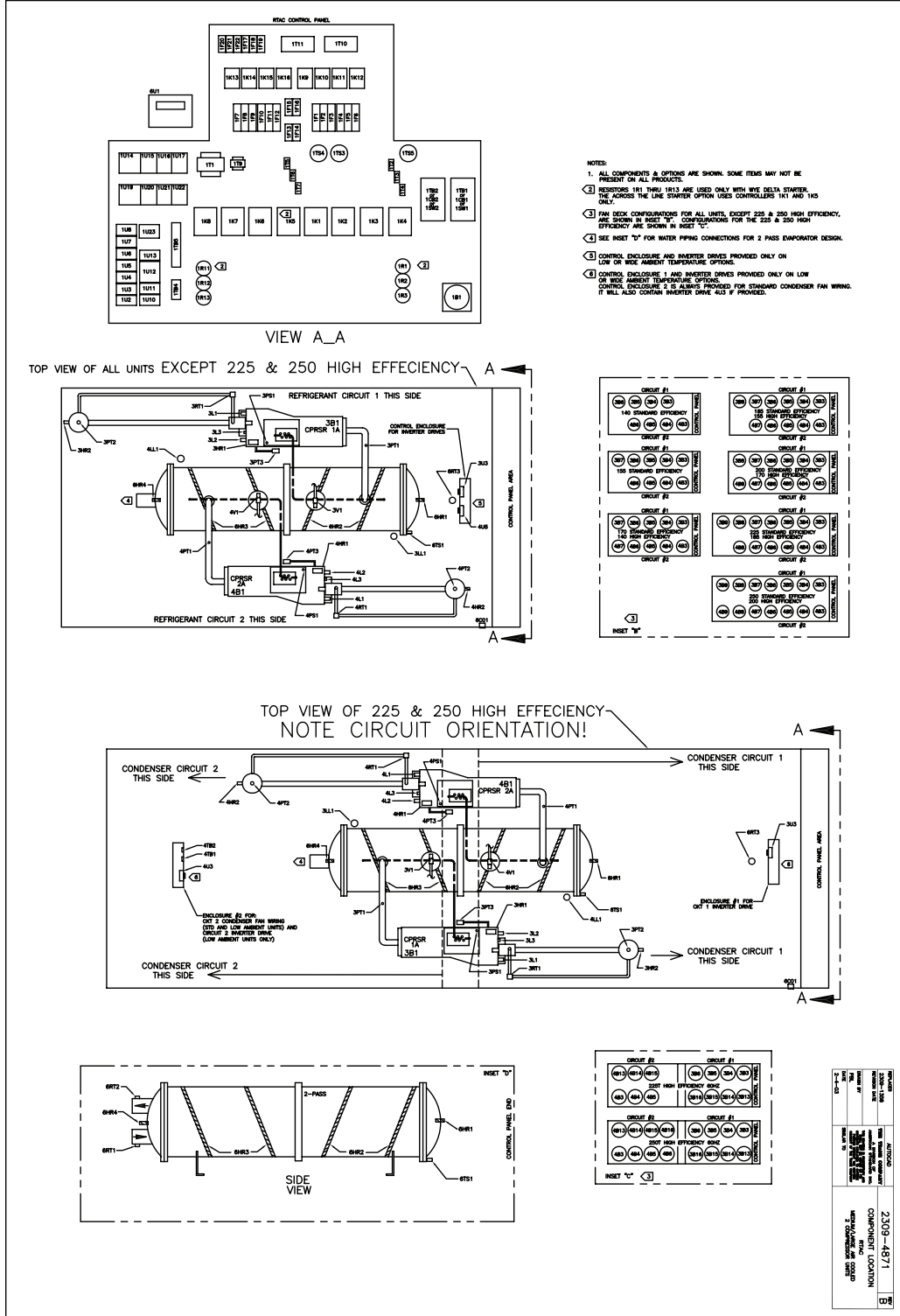

Wiring Diagram

Fig. XII-20 – Location of Component, 3 Length

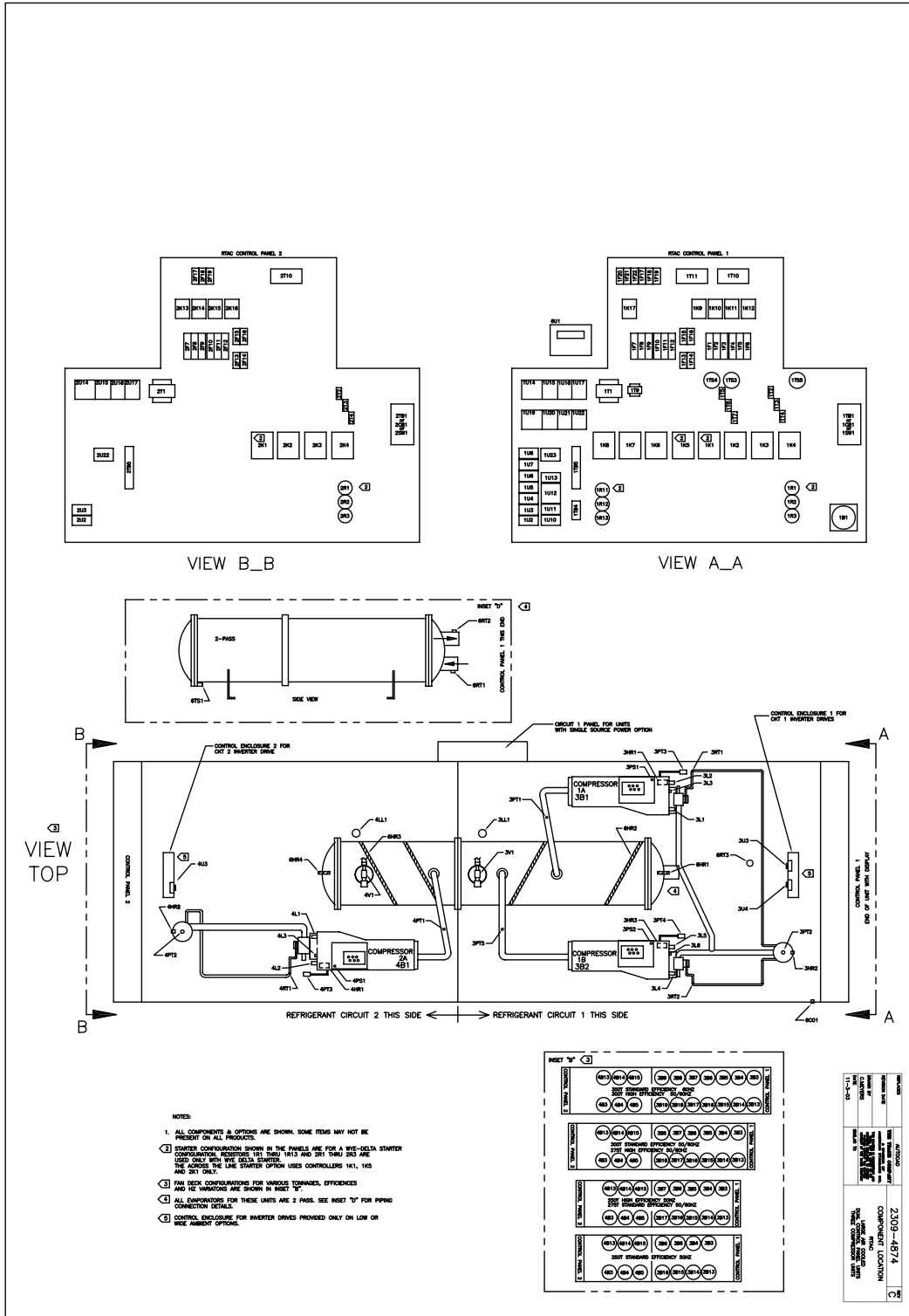

Wiring Diagram

Fig. XII-21 – Field wiring, 3&4 Length, Dual input

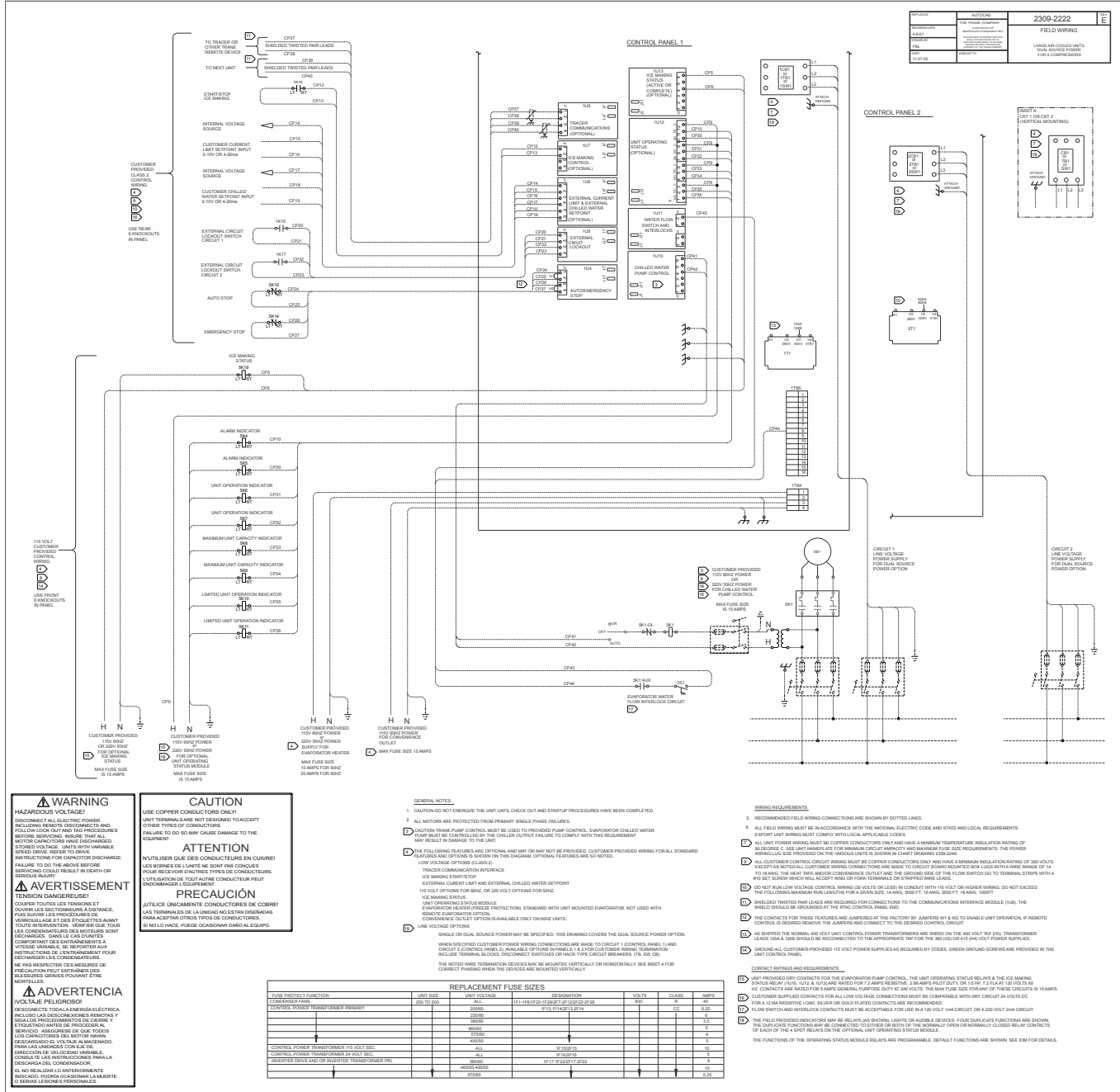

Wiring Diagram

Fig. XII-22 – Field Layout, all - Part 1

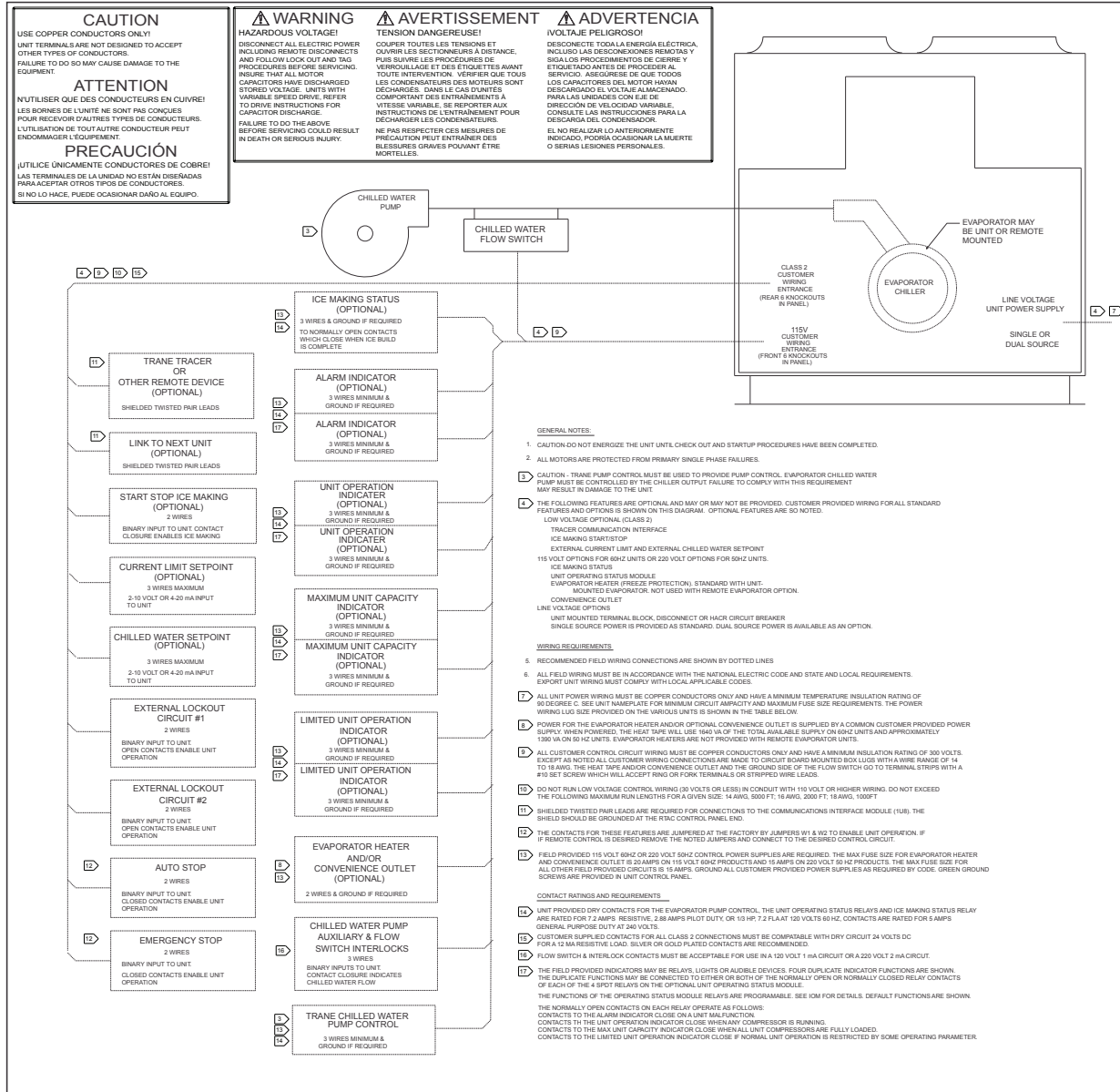



Wiring Diagram

Fig. XII-22 – Field Layout, all - Part 2

WIRE SIZE RANGE FOR FACTORY PROVIDED LUGS FOR CUSTOMER POWER WIRING CONNECTIONS						
CIRCUIT BREAKER OPTION						
VOLTAGE	SINGLE SOURCE POWER ELECTRICAL CIRCUIT 1 & 2		ELECTRICAL CIRCUIT 1 DUAL SOURCE POWER		ELECTRICAL CIRCUIT 2 DUAL SOURCE POWER	
	UNIT SIZE (TONS)	LUG WIRE SIZE RANGE	UNIT SIZE (TONS)	LUG WIRE SIZE RANGE	UNIT SIZE (TONS)	LUG WIRE SIZE RANGE
200/0/3	140	THREE 1/0 AWG - 500 MCM	140, 155, 170, 185, 200	TWO 3/0 AWG - 500 MCM	140, 155, 170, 185, 200, 225	TWO 3/0 AWG - 500 MCM
200/0/3	155, 170, 185, 200, 225, 250	FOUR 250 MCM - 500 MCM	225, 250	THREE 1/0 AWG - 500 MCM	250	THREE 1/0 AWG - 500 MCM
230/0/3	140, 155	THREE 1/0 AWG - 500 MCM	140, 155, 170, 185, 200	TWO 3/0 AWG - 500 MCM	140, 155, 170, 185, 200, 225	TWO 3/0 AWG - 500 MCM
230/0/3	170, 185, 200, 225, 250	FOUR 250 MCM - 500 MCM	225, 250	THREE 1/0 AWG - 500 MCM	250	THREE 1/0 AWG - 500 MCM
380/0/3	140, 155, 170, 185	TWO 3/0 AWG - 500 MCM	ALL	TWO 3/0 AWG - 500 MCM	ALL	TWO 3/0 AWG - 500 MCM
380/0/3	200, 225, 250	THREE 1/0 AWG - 500 MCM				
450/0/3	ALL	TWO 3/0 AWG - 500 MCM	ALL	TWO 3/0 AWG - 500 MCM	ALL	TWO 3/0 AWG - 500 MCM
575/0/3	ALL	TWO 3/0 AWG - 500 MCM	ALL	TWO 3/0 AWG - 500 MCM	ALL	TWO 3/0 AWG - 500 MCM
400/5/3	ALL	TWO 3/0 AWG - 500 MCM	ALL	TWO 3/0 AWG - 500 MCM	ALL	TWO 3/0 AWG - 500 MCM
DISCONNECT SWITCH OPTION						
VOLTAGE	SINGLE SOURCE POWER ELECTRICAL CIRCUIT 1 & 2		ELECTRICAL CIRCUIT 1 DUAL SOURCE POWER		ELECTRICAL CIRCUIT 2 DUAL SOURCE POWER	
	UNIT SIZE (TONS)	LUG WIRE SIZE RANGE	UNIT SIZE (TONS)	LUG WIRE SIZE RANGE	UNIT SIZE (TONS)	LUG WIRE SIZE RANGE
200/0/3	140, 155	THREE 1/0 AWG - 500 MCM	140, 155, 170, 185, 200	TWO 3/0 AWG - 500 MCM	140, 155, 170, 185, 200, 225	TWO 3/0 AWG - 500 MCM
200/0/3	170, 185, 200, 225, 250	FOUR 250 MCM - 500 MCM	225, 250	THREE 1/0 AWG - 500 MCM	250	THREE 1/0 AWG - 500 MCM
230/0/3	140, 155, 170	THREE 1/0 AWG - 500 MCM	140, 155, 170, 185, 200, 225	TWO 3/0 AWG - 500 MCM	140, 155, 170, 185, 200, 225	TWO 3/0 AWG - 500 MCM
230/0/3	185, 200, 225, 250	FOUR 250 MCM - 500 MCM	250	THREE 1/0 AWG - 500 MCM	250	THREE 1/0 AWG - 500 MCM
380/0/3	140, 155, 170, 185	TWO 3/0 AWG - 500 MCM	ALL	TWO 3/0 AWG - 500 MCM	ALL	TWO 3/0 AWG - 500 MCM
380/0/3	200, 225, 250	THREE 1/0 AWG - 500 MCM				
450/0/3	ALL	TWO 3/0 AWG - 500 MCM	ALL	TWO 3/0 AWG - 500 MCM	ALL	TWO 3/0 AWG - 500 MCM
575/0/3	ALL	TWO 3/0 AWG - 500 MCM	ALL	TWO 3/0 AWG - 500 MCM	ALL	TWO 3/0 AWG - 500 MCM
400/5/3	ALL	TWO 3/0 AWG - 500 MCM	ALL	TWO 3/0 AWG - 500 MCM	ALL	TWO 3/0 AWG - 500 MCM
TERMINAL BLOCK OR LUG OPTION						
VOLTAGE	SINGLE SOURCE POWER ELECTRICAL CIRCUIT 1 & 2		ELECTRICAL CIRCUIT 1 DUAL SOURCE POWER		ELECTRICAL CIRCUIT 2 DUAL SOURCE POWER	
	UNIT SIZE (TONS)	LUG WIRE SIZE RANGE	UNIT SIZE (TONS)	LUG WIRE SIZE RANGE	UNIT SIZE (TONS)	LUG WIRE SIZE RANGE
200/0/3	140	THREE 2 AWG - 600 MCM	140, 155, 170, 185, 200	TWO 2 AWG - 600 MCM	140, 155, 170, 185, 200, 225	TWO 2 AWG - 600 MCM
200/0/3	155, 170, 185, 200, 225, 250	FOUR 2 AWG - 600 MCM	225, 250	THREE 2 AWG - 600 MCM	250	THREE 2 AWG - 600 MCM
230/0/3	140, 155	THREE 2 AWG - 600 MCM	140, 155, 170, 185, 200, 225	TWO 2 AWG - 600 MCM	140, 155, 170, 185, 200, 225	TWO 2 AWG - 600 MCM
230/0/3	170, 185, 200, 225, 250	FOUR 2 AWG - 600 MCM	250	THREE 2 AWG - 600 MCM	250	THREE 2 AWG - 600 MCM
380/0/3	140, 155, 170, 185	TWO 2 AWG - 600 MCM	ALL	TWO 2 AWG - 600 MCM	ALL	TWO 2 AWG - 600 MCM
380/0/3	200, 225, 250	THREE 2 AWG - 600 MCM				
450/0/3	ALL	TWO 2 AWG - 600 MCM	ALL	TWO 2 AWG - 600 MCM	ALL	TWO 2 AWG - 600 MCM
575/0/3	ALL	TWO 2 AWG - 600 MCM	ALL	TWO 2 AWG - 600 MCM	ALL	TWO 2 AWG - 600 MCM
400/5/3	ALL	TWO 2 AWG - 600 MCM	ALL	TWO 2 AWG - 600 MCM	ALL	TWO 2 AWG - 600 MCM
REPLACEMENT FUSE SIZES						
FUSE PROTECT FUNCTION	UNIT SIZE	UNIT VOLTAGE/Hz	DESIGNATION	VOLTS	CLASS	AMPS
CONDENSER FANS	140 TO 250	ALL	1F1 THRU 1F2	600	R	40
CONTROL POWER TRANSFORMER PRIMARY	ALL		1F13, 1F14	600	CC	6.25
				600	CC	5
				600	CC	3.5
				600	CC	5
				600	CC	4
				600	CC	5
CONTROL POWER TRANSFORMER 115 VOLT SEC.	ALL	ALL	1F15	600	CC	10
CONTROL POWER TRANSFORMER 24 VOLT SEC.	ALL	ALL	1F16	600	CC	5
INVERTER DRIVE AND/OR INVERTER TRANSFORMER PRI.	ALL	380/60	1F17 THRU 1F22	600	CC	9
		460/60, 400/50		600	CC	10
		575/60		600	CC	6.25

REVISED	DATE	BY	DESCRIPTION
2309-2248			
FIELD LAYOUT			
2309-2248			
FIELD LAYOUT			
2309-2248			
FIELD LAYOUT			
2309-2248			
FIELD LAYOUT			
2309-2248			
FIELD LAYOUT			



Trane optimizes the performance of homes and buildings around the world. A business of Ingersoll Rand, the leader in creating and sustaining safe, comfortable and energy efficient environments, Trane offers a broad portfolio of advanced controls and HVAC systems, comprehensive building services, and parts. For more information, visit www.trane.com.br

Trane has a policy of continuous product and product data improvement and reserves the right to change design and specifications without notice.

© 2014 Trane
All rights reserved
RTAC-SVX002A-EN May 2014
Supersedes RTAC-SVX002-EN June 2013

We are committed to environmentally friendly
printing practices that reduce waste.

