



Installation, Operation, and Maintenance

CVHE, CVHF, and CVHG Water-Cooled CenTraVac™ Chillers With Tracer AdaptiView™ Control



Models: CVHE, CVHF, CVHG

X39641075080

⚠ SAFETY WARNING

Only qualified personnel should install and service the equipment. The installation, starting up, and servicing of heating, ventilating, and air-conditioning equipment can be hazardous and requires specific knowledge and training. Improperly installed, adjusted or altered equipment by an unqualified person could result in death or serious injury. When working on the equipment, observe all precautions in the literature and on the tags, stickers, and labels that are attached to the equipment.

March 2015

CVHE-SVX02H-EN





Introduction

Read this manual thoroughly before operating or servicing this unit.

Warnings, Cautions, and Notices

Safety advisories appear throughout this manual as required. Your personal safety and the proper operation of this machine depend upon the strict observance of these precautions.

The three types of advisories are defined as follows:

⚠ WARNING Indicates a potentially hazardous situation which, if not avoided, could result in death or serious injury.

⚠ CAUTION Indicates a potentially hazardous situation which, if not avoided, could result in minor or moderate injury. It could also be used to alert against unsafe practices.

NOTICE: Indicates a situation that could result in equipment or property-damage only accidents.

Important Environmental Concerns

Scientific research has shown that certain man-made chemicals can affect the earth's naturally occurring stratospheric ozone layer when released to the atmosphere. In particular, several of the identified chemicals that may affect the ozone layer are refrigerants that contain Chlorine, Fluorine and Carbon (CFCs) and those containing Hydrogen, Chlorine, Fluorine and Carbon (HCFCs). Not all refrigerants containing these compounds have the same potential impact to the environment. Trane advocates the responsible handling of all refrigerants-including industry replacements for CFCs such as HCFCs and HFCs.

Important Responsible Refrigerant Practices

Trane believes that responsible refrigerant practices are important to the environment, our customers, and the air conditioning industry. All technicians who handle refrigerants must be certified. The Federal Clean Air Act (Section 608) sets forth the requirements for handling, reclaiming, recovering and recycling of certain refrigerants and the equipment that is used in these service procedures. In addition, some states or municipalities may have additional requirements that must also be adhered to for responsible management of refrigerants. Know the applicable laws and follow them.

⚠ WARNING

Proper Field Wiring and Grounding Required!

Failure to follow code could result in death or serious injury. All field wiring **MUST** be performed by qualified personnel. Improperly installed and grounded field wiring poses **FIRE** and **ELECTROCUTION** hazards. To avoid these hazards, you **MUST** follow requirements for field wiring installation and grounding as described in NEC and your local/state electrical codes.

⚠ WARNING

Personal Protective Equipment (PPE) Required!

Installing/servicing this unit could result in exposure to electrical, mechanical and chemical hazards.

- Before installing/servicing this unit, technicians **MUST** put on all PPE required for the work being undertaken (Examples; cut resistant gloves/sleeves, butyl gloves, safety glasses, hard hat/bump cap, fall protection, electrical PPE and arc flash clothing). **ALWAYS** refer to appropriate Material Safety Data Sheets (MSDS)/Safety Data Sheets (SDS) and OSHA guidelines for proper PPE.
- When working with or around hazardous chemicals, **ALWAYS** refer to the appropriate MSDS/SDS and OSHA/GHS (Global Harmonized System of Classification and Labelling of Chemicals) guidelines for information on allowable personal exposure levels, proper respiratory protection and handling instructions.
- If there is a risk of energized electrical contact, arc, or flash, technicians **MUST** put on all PPE in accordance with OSHA, NFPA 70E, or other country-specific requirements for arc flash protection, **PRIOR** to servicing the unit. **NEVER PERFORM ANY SWITCHING, DISCONNECTING, OR VOLTAGE TESTING WITHOUT PROPER ELECTRICAL PPE AND ARC FLASH CLOTHING. ENSURE ELECTRICAL METERS AND EQUIPMENT ARE PROPERLY RATED FOR INTENDED VOLTAGE.**

Failure to follow instructions could result in death or serious injury.

⚠ WARNING**Refrigerant May Be Under Positive Pressure!**

Failure to recover refrigerant to relieve pressure or the use of non-approved refrigerants, refrigerant substitutes, or refrigerant additives could result in an explosion which could result in death or serious injury or equipment damage. System contains oil and refrigerant and may be under positive pressure. Recover refrigerant to relieve pressure before opening the system. See unit nameplate for refrigerant type. Do not use non-approved refrigerants, refrigerant substitutes, or refrigerant additives.

NOTICE:**Do Not Use Non-Compatible Parts or Materials!**

Use of non-compatible parts or materials could result in equipment damage. Only genuine Trane® replacement components with identical Trane part numbers should be used in Trane CenTraVac chillers. Trane assumes no responsibility for damages resulting from the use of non-compatible parts or materials.

Copyright

This document and the information in it are the property of Trane, and may not be used or reproduced in whole or in part without written permission. Trane reserves the right to revise this publication at any time, and to make changes to its content without obligation to notify any person of such revision or change.

Trademarks

All trademarks referenced in this document are the trademarks of their respective owners.

Revision History

CVHE-SVX02H-EN (31 Mar 2015)

- Labels added for clarification:
 - kPaA = kPa Absolute
 - kPaD = kPa Differential
 - kPaG = kPa Gauge
- Clarification of refrigerant container return (“[Installation Requirements and Contractor Responsibilities](#),” p. 8)
- Revised instruction for placement and tightening of flow probe (“[Water Flow Detection Controller and Sensor](#),” p. 22)
- “Equipment Damage” notice added to p. 35 and p. 69
- Clarification of evaporator eductor information (“[Oil and Refrigerant Pump](#),” p. 57)

- Added recommended material for cleaning material ifm efector® flow detection sensors ([Table 19](#), p. 70)

Factory Warranty Information

Compliance with the following is required to preserve the factory warranty:

All Unit Installations

Startup MUST be performed by Trane, or an authorized agent of Trane, to VALIDATE this WARRANTY. Contractor must provide a two-week startup notification to Trane (or an agent of Trane specifically authorized to perform startup).

Additional Requirements for Units Requiring Disassembly

When a new fully assembled chiller is shipped and received from our Trane manufacturing location and, for any reason, it requires disassembly or partial disassembly—which could include but is not limited to the evaporator, condenser, control panel, compressor/motor, purge, factory-mounted starter or any other components originally attached to the fully assembled unit—compliance with the following is required to preserve the factory warranty:

- Trane, or an agent of Trane specifically authorized to perform start-up and warranty of Trane® products, will perform or have direct on-site technical supervision of the disassembly and reassembly work.
- The installing contractor must notify Trane—or an agent of Trane specifically authorized to perform startup and warranty of Trane® products—two weeks in advance of the scheduled disassembly work to coordinate the disassembly and reassembly work.
- Start-up must be performed by Trane or an agent of Trane specifically authorized to perform startup and warranty of Trane® products.

Trane, or an agent of Trane specifically authorized to perform start-up and warranty of Trane® products, will provide qualified personnel and standard hand tools to perform the disassembly work at a location specified by the contractor. Trane, or an agent of Trane specifically authorized to perform start-up and warranty of Trane products, will perform or have direct on-site supervision of the disassembly and reassembly work. The contractor shall provide the rigging equipment such as chain falls, gantries, cranes, forklifts, etc. necessary for the disassembly and reassembly work and the required qualified personnel to operate the necessary rigging equipment.



Table of Contents

Introduction	2	Grooved Pipe Coupling	26
Warnings, Cautions, and Notices	2	Flange-Connection Adapters	26
Important Environmental Concerns	2	Victaulic Gasket Installation	27
Important Responsible Refrigerant Practices	2	Bolt-Tightening Sequence for Water Piping Connections	28
Table of Contents	4	Flanges with 4, 8, or 12 Bolts	28
Unit Model Number Description	6	Flanges with 16, 20, or 24 Bolts	28
Model Number Digit Description	7	Flanges with More than 24 Bolts	28
Pre-Installation	8	Evaporator Waterbox Covers	28
ASHRAE Standard 15 Compliance	8	Pressure Testing Waterside Piping	29
Unit Shipment	8	Vent Piping	30
Installation Requirements and Contractor Responsibilities	8	Refrigerant Vent Line	30
Storage Requirements	10	General Requirements	30
Unit Components	11	Purge Discharge	30
Unit Clearances and Weights	12	Vent Line Materials	30
Recommended Unit Clearances	12	Vent Line Sizing	30
General Weights	13	Vent Line Installation	31
Installation: Mechanical	16	Insulation	35
Operating Environment	16	Unit Insulation Requirements	35
Foundation Requirements	16	Insulation Thickness Requirements	35
Rigging	16	Installation: Controls	37
Standard Chiller Lift	16	UC800 Specifications	37
Special Lift Requirements	18	Wiring and Port Descriptions	37
Unit Isolation	18	Communication Interfaces	37
Isolation Pads	18	Rotary Switches	37
Spring Isolators	18	LED Description and Operation	37
Leveling the Unit	20	Installing the Tracer AdaptiView Display	41
Installation: Water Piping	21	Adjusting the Tracer AdaptiView Display Arm	42
Overview	21	Electrical Requirements	43
Water Treatment	21	Installation Requirements	43
Pressure Gauges	21	Electrical Requirements	43
Valves—Drains and Vents	21	Trane-Supplied Starter Wiring	44
Strainers	21	Customer-Supplied Remote Starter Wiring	45
Required Flow-Sensing Devices	21	Current Transformer and Potential Transformer Wire Sizing	46
Evaporator and Condenser Water Piping	23	Power Supply Wiring	47
Water Piping Connections	25	Three-Phase Power	47
Waterbox Locations	25	Circuit Breakers and Fused Disconnects	47

Power Factor Correction Capacitors (Optional)	47	Heat Recovery Cycle	66
Interconnecting Wiring	48	Auxiliary Condensers	67
Starter to Motor Wiring (Remote-Mounted Starters Only)	49	Control Panel Devices and Unit-Mounted Devices	67
Ground Wire Terminal Lugs	49	Unit Control Panel	67
Terminal Clamps	49	User-Defined Language Support	67
Wire Terminal Lugs	49	Unit Start-up and Shut-down Procedures .67	
Bus Bars	50	Daily Unit Start-up	67
Starter to Control Panel Wiring	50	Seasonal Unit Start-up	68
10kV–13.8kV Medium Voltage Installation . 51		Daily Unit Shut-down	68
10kV–13.8kV Medium Voltage Motor . . .	51	Recommended Maintenance	69
Motor Terminal Box	51	Record Keeping Forms	69
Motor Supply Wiring	52	Normal Operation	69
System Control Circuit Wiring (Field Wiring)	53	Recommended Compressor Oil Change . .71	
Water Pump Interlock Circuits and Flow Switch Input	54	Purge System	71
Temperature Sensor Circuits	54	Leak Checking Based on Purge Pump Out Time	71
Optional Control and Output Circuits . . .	55	Long Term Unit Storage	72
Optional Tracer Communication Interface	55	Refrigerant Charge	72
Unit Start-up/Commissioning	55	Recommended System Maintenance . . .	73
Starter Module Configuration	55	Waterbox Removal and Installation	75
Schematic Wiring Drawings	55	Discussion	75
Operating Principles	56	Procedure	75
General Requirements	56	Reassembly	76
Cooling Cycle	56	Torque Requirements	76
Oil and Refrigerant Pump	57	Connection Devices Information	78
Motor Cooling System	59	Forms and Check Sheets	79
Tracer AdaptiView Display	59		
Start-up and Shut-down	60		
Sequence of Operation	60		
Software Operation Overview Diagram .	60		
Start-up Sequence of Operation—Wye-Delta	61		
Power Up Diagram	63		
Ice Machine Control	63		
Free Cooling Cycle	65		
Free Cooling (FRCL)	65		
Hot Gas Bypass (HGBP)	65		
Hot Water Control	66		



Unit Model Number Description

The unit nameplate is located on the left side of the control panel. A typical unit nameplate is illustrated in [Figure 1](#) and contains the following information:

- Unit model and size descriptor
- Unit electrical requirements
- Correct operating charge and refrigerant type
- Unit test pressures and maximum operating pressures
- Unit literature

Serial Number. The unit serial number provides the specific chiller identity. Always provide this serial number when calling for service or during parts identification.

Service Model Number. The service model represents the unit as built for service purposes. It identifies the selections of variable unit features required when ordering replacements parts or requesting service.

Note: Unit-mounted starters are identified by a separate number found on the starter.

Product Description Block. The CenTraVac™ models are defined and built using the Product Definition and Selection (PDS) system. This system describes the product offerings using a product coding block which is made up of feature categories and codes that identifies all characteristics of a unit.

Figure 1. Typical unit nameplate

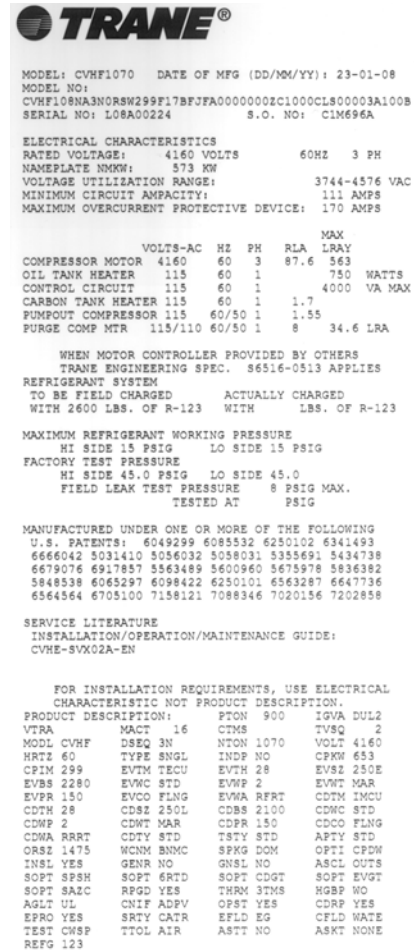



Model Number Digit Description

Digit	Description
1-3	Unit Type
4	Development Sequence
5-7	Nominal Tonnage
8	Unit Voltage
9	Unit Type
10-11	Design Sequence
12	Hot Gas Bypass
13	Starter Type
14	Control Enclosure
15	Compressor Motor Power (CPKW)
16-18	Compressor Impeller Cutback
19	Evaporator Shell Size
20	Evaporator Tube Bundle (nominal tons)
21	Evaporator Tubes
22	Evaporator waterbox
23	Condenser Shell Size
24	Condenser Tube Bundle (nominal tons)
25	Condenser Tubes
26	Condenser waterbox
27	Heat Recovery Condenser Shell Size
28	Heat Recovery Condenser Tube Bundle (nominal tons)
29	Heat Recovery Tubes
30	Heat Recovery Condenser waterbox
31	Auxiliary Condenser Size & waterbox
32	Auxiliary Condenser Tubes
33	Orifice Size
34	Orifice Size
35	Unit Option-Insulation & Rupture Guard
36	Enhanced Protection
37	Generic BAS
38	Extended Operation
39	Tracer Communication
40	Condenser Refrigerant Control
41	Manufacturing Location
42	Special Options
43	Water Flow Control
44	Chilled Water Reset
45	Heat Recovery Temperature Sensors
46	Gas Powered Chiller
47	Compressor Motor Frame Size
48	Volute Discharge Angle
49	Operating Status
50	Industrial Chiller Package
51	Control Power Transformer
52	Motor & Terminal Board Config



Pre-Installation

ASHRAE Standard 15 Compliance

Trane recommends that indoor CenTraVac unit installations fully meet or exceed the guidelines of the current version of ASHRAE Standard 15, in addition to any applicable national, state, or local requirements. This typically includes:

- A refrigerant monitor or detector that is capable of monitoring and alarming within the acceptable exposure level of the refrigerant, and that can actuate mechanical ventilation.
- Audible and visual alarms, activated by the refrigerant monitor, inside the equipment room and outside of every entrance.
- The equipment room should be properly vented to the outdoors, using mechanical ventilation that can be activated by the refrigerant monitor.
- The purge discharge and the rupture disk must be properly piped to the outdoors.
- If required by local or other codes, a self-contained breathing apparatus should be available in close proximity to the equipment room.

Refer to the latest copy of ASHRAE Standard 15 for specific guidelines. Trane assumes no responsibility for any economic, health, or environmental issues that may result from an equipment room's design or function.

Unit Shipment

Inspect unit while it is still on the truck for any shipping damage. The chiller ships shrink-wrapped in a 0.010-in. (0.254 mm) recyclable film protective covering. Do not remove shrink-wrap for inspection! Inspect for damage to the shrink-wrap and determine if physical damage has occurred.

Each chiller ships from the factory as a hermetically assembled package; it is factory-assembled, -wired, and -tested. All openings except for the waterbox vent and drain holes are covered or plugged to prevent contamination during shipment and handling. [Figure 2, p. 11](#) shows an illustration of a typical unit and its components. As soon as the unit arrives at the job site, inspect it thoroughly for damage and material shortages. In addition:

1. Verify the hermetic integrity of the unit by checking the chiller pressure for an indication of holding charge pressure.
2. To prevent damaging moisture from entering the unit and causing corrosion, each chiller is pressurized with 3 to 5 psig (20.7 to 34.5 kPaG) of dry nitrogen before shipment.

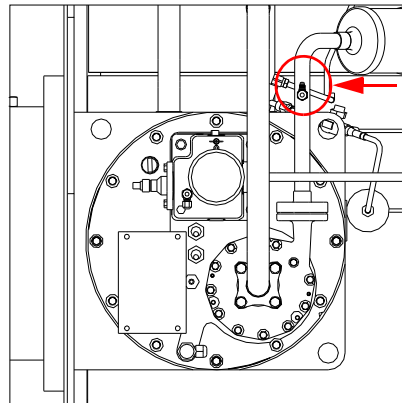

Note: The holding charge should register approximately 5 psig (34.5 kPaG) at 72°F (22.2°C). Place a gauge on the access valve provided (indicated by arrow and circle in the preceding figure) on the refrigerant pump discharge line to verify the holding charge. If the charge has escaped, contact your local Trane sales office for instructions.

3. The loose parts box and isolator pads ship on top of the control panel box.
4. Check the oil sump sight glasses to verify that the sump was factory-charged with 9 gallons (34.1 L) of oil. If no oil level is visible, contact your local Trane sales office.

Installation Requirements and Contractor Responsibilities

A list of the contractor responsibilities typically associated with the unit installation process is provided.

⚠ WARNING
Combustible Material!
Failure to follow this instruction could result in death or serious injury or equipment damage. Shrink-wrap is a combustible material. Avoid open flames and hot sparks.

Note: The chiller should remain within its protective shrink-wrap covering during storage.

Type of Requirement	Trane Supplied Trane Installed	Trane Supplied Field Installed	Field Supplied Field Installed
Foundation			<ul style="list-style-type: none"> Meet foundation requirements
Rigging			<ul style="list-style-type: none"> Safety chains Clevis connectors Lifting beam
Disassembly/Reassembly (as required)	<ul style="list-style-type: none"> Trane will perform or have direct on-site supervision of the disassembly and reassembly work (contact your local Trane office for pricing) 		
Isolation		<ul style="list-style-type: none"> Isolation pads or spring isolators 	<ul style="list-style-type: none"> Isolation pads or spring isolators
Electrical	<ul style="list-style-type: none"> Circuit breakers or fusible disconnects (optional) Unit mounted starter (optional) PFCCs (optional) 	<ul style="list-style-type: none"> Jumper bars Temperature sensor (optional outdoor air) Flow switches (may be field supplied) Remote-mounted starter (optional) 	<ul style="list-style-type: none"> Circuit breakers or fusible disconnects (optional) Electrical connections to unit mounted starter (optional) Electrical connections to remote mounted starter (optional) Wiring sizes per submittal and NEC PFCCs (remote mounted starter optional only) Terminal lugs Ground connection(s) Jumper bars BAS wiring (optional) IPC wiring (AFD and remote-mounted starters only) Control voltage wiring (AFD and remote-mounted starters only) Oil pump interlock wiring (AFD and remote mounted starters only) High condenser pressure interlock wiring (AFD and remote mounted starters only) Chilled water pump contactor and wiring including interlock Condenser water pump contactor and wiring including interlock Option relays and wiring
Water piping		<ul style="list-style-type: none"> Flow sensing devices (may be field supplied) 	<ul style="list-style-type: none"> Taps for flow sensing devices Taps for thermometers and gauges Thermometers Strainers (as required) Water flow pressure gauges Isolation and balancing valves in water piping Vents and drain on waterbox valves (one each per pass) Pressure relief valves (for waterboxes as required)
Relief	<ul style="list-style-type: none"> Rupture disk assembly 	<ul style="list-style-type: none"> RuptureGuard™ (optional) 	<ul style="list-style-type: none"> Vent line and flexible connector and vent line from rupture disk to atmosphere
Insulation	<ul style="list-style-type: none"> Insulation (optional) 		<ul style="list-style-type: none"> Insulation Chiller feet insulation
Water Piping Connection Components	<ul style="list-style-type: none"> Flanged (optional) Welded on flange for 300 psig (2068.4 kPaG) waterboxes 	<ul style="list-style-type: none"> Flanged (optional) Victaulic® to flange adapter for 150 psig (1034.2 kPaG) waterboxes 	<ul style="list-style-type: none"> Victaulic Victaulic coupling for 150 psig (1034.2 kPaG) and 300 psig (2068.4 kPaG) waterboxes Fasteners for flanged-type connections (optional)
Other Materials			<ul style="list-style-type: none"> R-22 refrigerant (1 lb [0.45 kg] maximum per machine as needed to perform leak testing) Dry nitrogen (8 psig [55.2 kPaG] maximum per machine as needed)
"CenTraVac™ Installation Completion Check Sheet and Request for Trane Service" (CTV-ADF001*-EN; refer to "Forms and Check Sheets," p. 79)			<ul style="list-style-type: none"> To be completed by installing contractor prior to contacting Trane for start-up



Pre-Installation

Type of Requirement	Trane Supplied Trane Installed	Trane Supplied Field Installed	Field Supplied Field Installed
Chiller start-up commissioning ^(a)	<ul style="list-style-type: none"> Trane, or an agent of Trane specifically authorized to perform start-up of Trane® products 		
Post-commissioning transport of empty refrigerant containers for return or recycling			<ul style="list-style-type: none"> Move empty refrigerant containers to an easily accessible point of loading

(a) Start-up must be performed by Trane or an agent of Trane specifically authorized to perform start-up and warranty of Trane® products. Contractor shall provide Trane (or an agent of Trane specifically authorized to perform start-up) with notice of the scheduled start-up at least two weeks prior to the scheduled start-up.

Storage Requirements

NOTICE:

Insulation Damage!

Do not expose unit to direct sunlight as it could result in damage to factory-installed insulation.

Less than 1 month	1–6 months	Greater than 6 months
Location requirements: <ul style="list-style-type: none"> solid foundation vibration free dry temperature range -40°F to 158°F (-40°C to 70°C) 	Location requirements: <ul style="list-style-type: none"> solid foundation vibration free dry temperature range -40°F to 158°F (-40°C to 70°C) 	Location requirements: <ul style="list-style-type: none"> solid foundation vibration free dry temperature range -40°F to 158°F (-40°C to 70°C)
<ul style="list-style-type: none"> Do not remove any plastic coverings Do not charge the chiller with refrigerant If additional refrigerant is on site, follow manufactures storage requirements 	<ul style="list-style-type: none"> Do not remove any plastic coverings Do not charge the chiller with refrigerant If additional refrigerant is on site, follow manufactures storage requirements 	<ul style="list-style-type: none"> Do not remove any plastic coverings Do not charge the chiller with refrigerant If additional refrigerant is on site, follow manufactures storage requirements
<ul style="list-style-type: none"> Verify dry nitrogen pressure using gauge located on the evaporator shell reads 3 to 5 psig (20.7 to 34.5 kPaG) Notify the local Trane office if charge has escaped 	<ul style="list-style-type: none"> Verify dry nitrogen pressure using gauge located on the evaporator shell reads 3 to 5 psig (20.7 to 34.5 kPaG) Notify the local Trane office if charge has escaped 	<ul style="list-style-type: none"> Verify dry nitrogen pressure using gauge located on the evaporator shell reads 3 to 5 psig (20.7 to 34.5 kPaG) Notify the local Trane office if charge has escaped
<ul style="list-style-type: none"> Do not operate purge unit 	<ul style="list-style-type: none"> Do not operate purge unit Verify waterbox and tube bundles are clean and dry 	<ul style="list-style-type: none"> Do not operate purge unit Verify waterbox and tube bundles are clean and dry
		<ul style="list-style-type: none"> Conduct an oil analysis and verify no oil breakdown^(a) Repeat yearly Replace oil if breakdown has occurred If no oil analysis program has been followed, replace oil prior to start up
		<ul style="list-style-type: none"> Every 6 months, start the oil pump and rotate compressor shaft about 450° to prevent potential bearing issues^(a) Contact your local Trane office to perform this task

Note: Chillers stored 5 years or longer should be inspected every 5 years by a qualified service organization for leaks.

(a) If protective plastic coverings need to be removed for access and/or service, contact your local Trane office.

Unit Components

Note: The control panel side of the unit is always designated as the front side of the unit.

Figure 2. Typical CVHF CenTraVac chiller

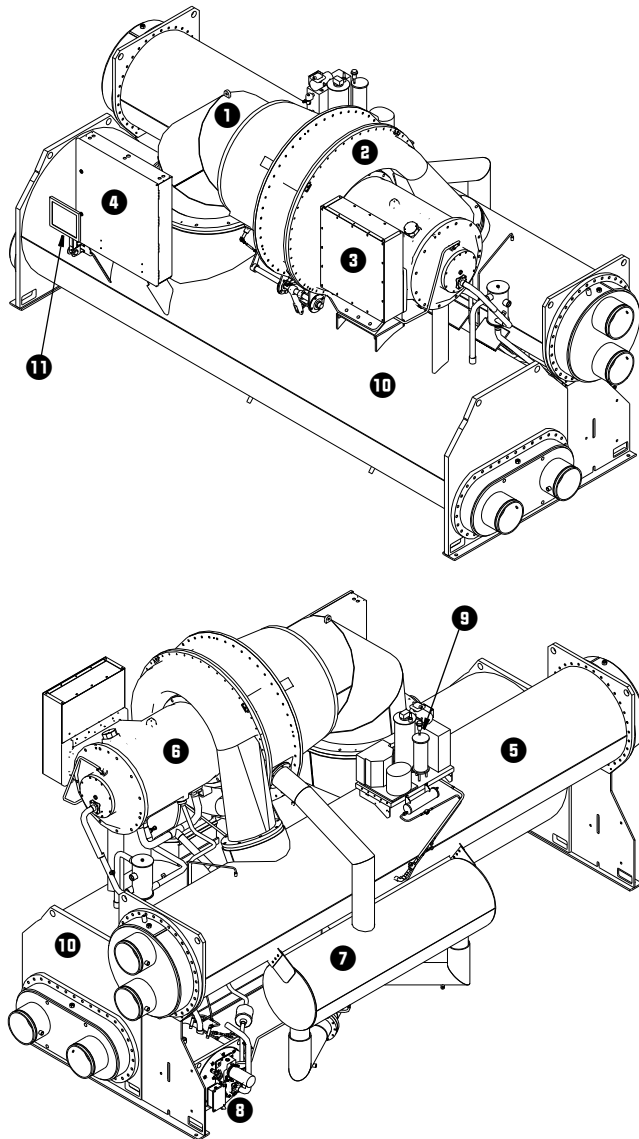

- | | |
|------------------|----------------------|
| 1. Suction Elbow | 7. Economizer |
| 2. Compressor | 8. Oil Tank Assembly |
| 3. Terminal Box | 9. Purge |
| 4. Control Panel | 10. Evaporator |
| 5. Condenser | 11. Display Panel |
| 6. Motor Housing | |



Unit Clearances and Weights

Recommended Unit Clearances

Adequate clearances around and above the chiller are required to allow sufficient access for service and maintenance operations. Specific unit clearance requirements are indicated in the submittal package provided for your unit.

- Do NOT install piping or conduit above the compressor motor assembly or behind the suction elbow of the unit.

- Minimum vertical clearance above the unit is 3 feet (92 cm).
- Use a housekeeping pad to provide better service clearances; refer to submittal for more information.

Per NEC Article 110: Unit mounted starters from 0–600V require a 42 inch (107 cm) clearance, 601–2500V require a 48 inch (122 cm) clearance, and 2501–9000V require a 60 inch (152 cm) clearance. Refer to NEC and local electrical codes for starter and control panel clearance requirements.

Figure 3. Clearance requirements

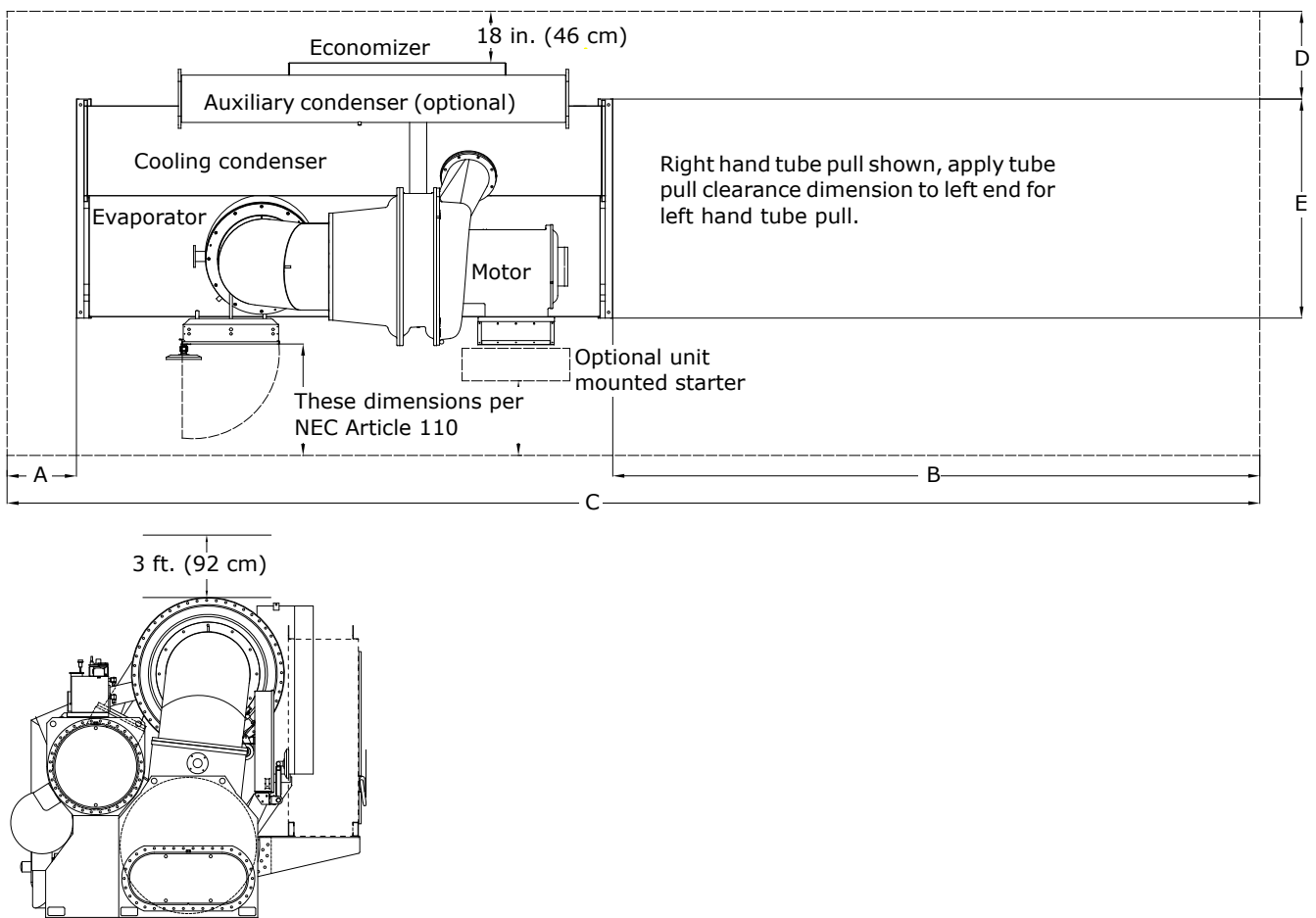

Table 1. Clearance requirements^(a)

Evaporator Size	Shell Combo	A		B		C		D		E	
		inch	cm	inch	cm	inch	cm	inch	cm	inch	cm
032 Short/Long	Short/Short	45	114	141	358	321	815	34	86	53	134
	Short/Long	77	195	219	556	431	1094	34	86	53	134
	Long/Long	45	114	187	474	411	1043	34	86	53	134
050 Short/Long	Short/Short	45	114	141	358	321	815	40	101	62	157
	Short/Long	78	198	219	556	431	1094	40	101	62	157
	Long/Long	45	114	187	474	411	1043	40	101	62	157
080 Short/Long	Short/Short	53	134	141	358	329	835	36	91	76	193
	Short/Long	85	215	219	556	439	1115	36	91	76	193
	Long/Long	53	134	187	474	419	1064	36	91	76	193
142 Medium/Long/ Extended 210 Long	Medium Long	78	198	207	525	444	1127	44	111	92	233
	Long/Long	58	147	187	474	424	1076	44	111	92	233
	Extended/Long	58	147	209	530	469	1191	44	111	92	233
	Long/Long	59	149	187	474	426	1082	47	119	102	259
250 Extended	Extended/Long	63	160	209	530	475	1206	43	109	115	292

(a) All dimensions are approximate; refer to the unit submittal package for exact dimensions for your unit.

General Weights

The unit weight information provided in [Table 2](#) should be used for general information purposes only. Trane does not recommend using this weight information for considerations relative to chiller handling. The large number of variances between chiller selections drives variances in chiller weights that are not recognized in this table. For specific weights for your chiller, refer to your submittal package.

The values in [Table 2](#) representing chiller weights include the following:

- TECU 0.028-in. tube wall.
- 150 psig (1034.2 kPaG) non-marine waterboxes.

- Operating weights include the largest possible refrigerant charge.
- Chillers with starter weights include the weight of the heaviest possible starter.
- Heaviest possible bundle and heaviest possible motor combination for the application family chiller.

The values in [Table 2](#) representing chiller weights do NOT include the following options:

- INDP (Industrial Control Panel) option—add 50 lb (23 kg)
- CPTR (Control Panel Transformer) option—add 130 lb (50 kg)
- SMP (Supplemental Motor Protection) option—add 500 lb (230 kg)

Table 2. Unit weights

Model	NTON	CPKW	EVSZ	CDSZ	Weight without Starter				Weight with Starters			
					Operating		Shipping		Operating		Shipping	
					lb	kg	lb	kg	lb	kg	lb	kg
CVHE (60 Hz)	230-320	287	032S	032S	14918	6767	13730	6228	17143	7776	15955	7237
	230-320	287	032S	032L	15484	7023	14195	6439	17709	8033	16420	7448
	230-320	287	032L	032L	16391	7435	14856	6739	18616	8444	17081	7748
	230-320	287	050S	050S	19275	8743	17163	7785	21500	9752	19388	8794
	230-320	287	050S	050L	20211	9168	17938	8137	22436	10177	20163	9146
	230-320	287	050L	050L	21738	9860	18910	8577	23963	10869	21135	9587
	360-500	453	050S	050S	20812	9440	18700	8482	23037	10449	20925	9491
	360-500	453	050S	050L	21748	9865	19475	8834	23973	10874	21700	9843
	360-500	453	050L	050L	23275	10557	20447	9275	25500	11567	22672	10284
	360-500	453	050S	080S	23540	10678	20910	9485	25765	11687	23135	10494
	360-500	453	050L	080L	26586	12059	23193	10520	28811	13068	25418	11529
	360-500	453	080S	080S	28529	12941	25002	11341	30754	13950	27227	12350
	360-500	453	080S	080L	30098	13652	26313	11935	32323	14661	28538	12945
	360-500	453	080L	080L	32186	14599	27893	12652	34411	15609	30118	13661



Unit Clearances and Weights

Table 2. Unit weights (continued)

Model	NTON	CPKW	EVSZ	CDSZ	Weight without Starter				Weight with Starters			
					Operating		Shipping		Operating		Shipping	
					lb	kg	lb	kg	lb	kg	lb	kg
CVHF (60 Hz)	350-570	588	050S	050S	19319	8763	17207	7805	22260	10097	20148	9139
	350-570	588	050S	050L	20255	9188	17982	8156	23196	10522	20923	9491
	350-570	588	050L	050L	21682	9835	18954	8597	24623	11169	21895	9931
	350-570	588	050S	080S	21997	9978	19417	8807	24938	11312	22358	10141
	350-570	588	050L	080L	24993	11337	21700	9843	27934	12671	24641	11177
	350-570	588	080S	080S	27010	12252	23483	10652	29951	13586	26424	11986
	350-570	588	080S	080L	28579	12963	24794	11246	31520	14297	27735	12580
	350-570	588	080L	080L	30667	13910	26374	11963	33608	15244	29315	13297
	620-870	957	080S	080S	29594	13424	26068	11849	32484	14734	28957	13135
	620-870	957	080S	080L	31163	14135	27378	12418	34053	15446	30268	13729
	620-870	957	080L	080L	33251	15082	28958	13135	36141	16393	31848	14446
	620-870	957	080L	142L	38501	17464	32413	14702	41391	18775	35303	16013
	620-870	957	142M	142L	39419	17880	33487	15189	41734	18930	35646	16169
	620-870	957	142L	142L	40660	18443	34310	15563	42309	19191	36377	16500
	650-910	957	080S	080S	29385	13329	25858	11729	32275	14640	28748	13040
	650-910	957	080S	080L	30954	14040	27169	12324	33844	15351	30059	13635
	650-910	957	080L	080L	33042	14988	28749	13040	35932	16298	31639	14351
	650-910	957	080L	142L	38292	17369	32204	14607	41182	18680	35094	15918
	650-910	957	142M	142L	39210	17785	33278	15095	41525	18835	35437	16074
	650-910	957	142L	142L	40451	18348	34101	15468	42100	19096	36168	16406
	1070-1300	1228	080L	142L	40819	18515	34731	15754	43341	19659	36991	16779
	1070-1300	1228	142M	142L	41511	18829	35579	16138	43150	19573	37218	16882
	1070-1300	1228	142L	142L	42752	19392	36402	16512	44391	20135	38041	17255
	1070-1300	1228	142E	142L	43986	19952	37292	16915	45625	20695	38931	17659
	1070-1300	1228	142M	210L	46024	20876	38676	17543	47726	21648	40378	18315
	1070-1300	1228	142L	210L	47403	21502	39591	17958	49105	22274	41293	18730
	1070-1300	1228	142E	210L	48887	22175	40580	18407	50589	22947	42282	19179
	1070-1300	1228	210L	210L	51651	23428	43440	19704	53290	24172	45079	20447
1070-1300	1228	250E	250L	60905	27626	50350	22838	62544	28369	51989	23582	
1470	1340	210L	210L	54232	24599	46021	20875	55871	25343	47660	21618	
1470-1720	1340	142L	210L	49984	22672	42172	19129	51686	23444	43874	19901	
1470-1720	1340	142E	210L	51468	23345	43161	19578	53170	24118	44863	20350	
1470-1720	1340	250E	250L	63486	28797	52931	24009	65125	29540	54570	24753	
CVHE (50 Hz)	190-270	242	032S	032S	14946	6779	13758	6241	16585	7523	15397	6984
	190-270	242	032S	032L	15512	7036	14223	6451	17151	7780	15862	7195
	190-270	242	032L	032L	16419	7448	14884	6751	18058	8191	16523	7495
	190-270	242	050S	050S	19303	8756	17191	7798	20942	9499	18830	8541
	190-270	242	050S	050L	20239	9180	17966	8149	21878	9924	19605	8893
	190-270	242	050L	050L	21766	9873	18938	8590	23405	10616	20577	9334
	300-420	379	050S	050S	20195	9160	18083	8202	21834	9904	19722	8946
	300-420	379	050S	050L	21131	9585	18858	8554	22770	10328	20497	9297
	300-420	379	050L	050L	22658	10277	19830	8995	24297	11021	21469	9738
	300-420	379	080S	080S	27912	12661	24385	11061	29551	13404	26024	11804
	300-420	379	080S	080L	29481	13372	25696	11656	31120	14116	27335	12399
	300-420	379	080L	080L	31569	14319	27276	12372	33208	15063	28915	13116

Table 2. Unit weights (continued)

Model	NTON	CPKW	EVSZ	CDSZ	Weight without Starter				Weight with Starters			
					Operating		Shipping		Operating		Shipping	
					lb	kg	lb	kg	lb	kg	lb	kg
CVHG (50 Hz)	480-565	489	050S	050S	22009	9983	19897	9025	23648	10727	21536	9769
	480-565	489	050S	050L	22945	10408	20672	9377	24584	11151	22311	10120
	480-565	489	050L	050L	24372	11055	21644	9818	26011	11798	23283	10561
	480-565	489	080S	080S	29726	13483	26199	11884	31365	14227	27838	12627
	480-565	489	080S	080L	31295	14195	27510	12478	32934	14939	29149	13222
	480-565	489	080L	080L	33383	15142	29090	13195	35022	15886	30729	13938
	670-780	621	080S	080S	31037	14078	27510	12478	32676	14822	29149	13222
	670-780	621	080S	080L	32606	14790	28821	13073	34245	15533	30460	13816
	670-780	621	080L	080L	34694	15737	30401	13790	36333	16480	32040	14533
	670-780	621	142M	142L	41176	18677	35244	15986	42815	19421	36883	16730
	670-780	621	142L	142L	42417	19240	36067	16360	44056	19983	37706	17103
	920-1100	892	142M	210L	46868	21259	39520	17926	48570	22031	41222	18698
	920-1100	892	142L	210L	48247	21884	40435	18341	49949	22656	42137	19113
	920-1100	892	142E	210L	49731	22558	41424	18790	51433	23330	43126	19562
	920-1100	892	210L	210L	52495	23811	44284	20087	54134	24555	45923	20830



Installation: Mechanical

Operating Environment

Important:

- The standard chiller is designed for indoor use only and as such has NEMA Type 1 enclosures.
- For chillers in unheated equipment rooms, contact your local Trane service agency for methods to ensure that the oil temperature is maintained suitable for proper operation of the chiller.

To ensure that electrical components operate properly, do not locate the chiller in an area exposed to dust, dirt, corrosive fumes, or excessive heat and humidity. The maximum ambient temperature for chiller operation is 104°F (40°C).

NOTICE:

Equipment Failure!

Unit operating at ambient temperatures exceeding 104°F (40°C) could fatigue the unit's rupture disk, causing it to break at a reduced refrigerant pressure (<15 psig [<103.4 kPaG]). Starter component damage could also occur due to the panel's inability to dissipate heat adequately. If any of these adverse operating conditions are present, take necessary action to improve the equipment room environment.

Foundation Requirements

Chiller mounting surface must be:

- rigid non-warping mounting pads or a concrete foundation.
- able to support the chiller at its full operating weight (including completed piping, and full operating charges of refrigerant, oil and water.)

For proper unit operation, the chiller must be level within 1/16 in. (1.6 mm) over its length and width when set into place on the mounting surface. [Table 2, p. 13](#) shows approximate weights for various chiller sizes and options.

Note: For specific weight information, refer to the unit submittal package.

Important: Trane will not assume responsibility for equipment problems resulting from an improperly designed or constructed foundation.

Rigging

Lifting is the recommended method for moving chillers. Suggested lifting arrangements for standard units are described in "[Standard Chiller Lift](#)," p. 16.

Note: The lifting beam used for Simplex units must be at least 16 feet (4.8768 meters) long.

⚠ WARNING

Heavy Objects!

Failure to properly lift unit could result in death or serious injury, or equipment or property-only damage. Do not use cables (chains or slings) except as shown in [Figure 4, p. 17](#). Each of the cables (chains or slings) used to lift the unit must be capable of supporting the entire weight of the unit. Lifting cables (chains or slings) may not be of the same length. Adjust as necessary for even unit lift.

⚠ WARNING

Improper Unit Lift!

Failure to properly lift unit could result in death or serious injury, or equipment or property-only damage. Test lift unit approximately 24 inches (61 cm) to verify proper center of gravity lift point. To avoid dropping of unit, reposition lifting point if unit is not level.

NOTICE:

Wiring Damage!

Damage to unit wiring could result in equipment failure. Care must be taken during rigging, assembly and disassembly to avoid damaging unit wiring.

Standard Chiller Lift

1. Insert clevis connections at the points indicated in [Figure 4, p. 17](#). A 2 in. (50.8 mm) diameter lifting hole is provided at each of these points.
2. Attach the lifting chains or cables.
3. Once the lifting cables are in place, attach a safety chain or cable between the first-stage casing of the compressor and the lifting beam.

Important: There should not be tension on this safety cable; the cable is used only to prevent the unit from rolling during the lift.

4. Position isolator pads or spring isolators beneath the chiller feet (refer to "[Unit Isolation](#)," p. 18 for instructions).

Note: Follow instructions provided by the spring isolator manufacturer, being careful to not damage isolator adjustment bolt.

5. Once the isolators are in place, lower the chiller—working from end to end—in small increments to maintain stability.
6. When lift is complete, detach the clevis connections and safety chain.

Figure 4. Typical rigging arrangements for Simplex units

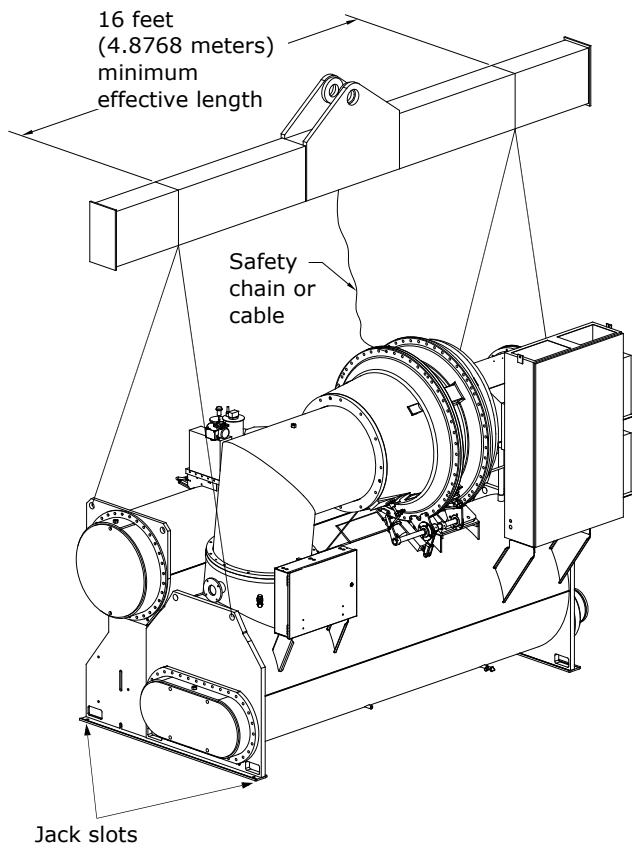
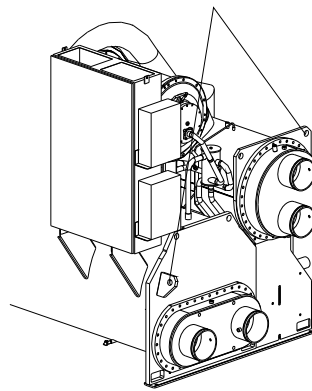
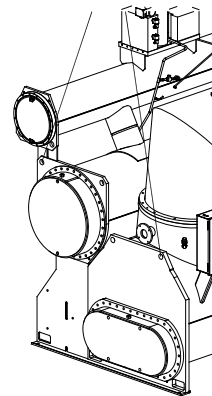

Figure 4. Typical rigging arrangements for Simplex units (continued)



800 Short shells only—
use rigging flange



Auxiliary option

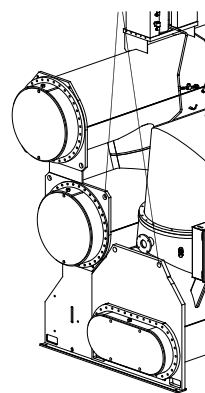

Heat recovery option

Special Lift Requirements

NOTICE:

Oil Loss!

Failure to prevent oil migration out of the oil tank could result in equipment failure or property-only damage. To prevent oil migration out of the oil tank during lifting procedures, remove the oil from the oil tank if the unit will be lifted at any angle greater than 15° from horizontal end-to-end. If oil is allowed to run out of the oil tank into other areas of the chiller, it will be extremely difficult to return the oil to the oil tank even during operation.

NOTICE:

Equipment Damage!

Moving the chiller using a fork lift could result in equipment or property-only damage. Do not use a fork lift to move the chiller!

NOTICE:

Compressor Alignment!

Failure to preserve compressor alignment could result in equipment or property-only damage. Lifting the compressor/motor assembly from the shells without factory-installed doweling in the compressor casting flanges could result in misalignment of the compressor castings.

If the chiller cannot be moved using a standard chiller lift, consider the following:

- When job site conditions require rigging of the chiller at an angle greater than 45° from horizontal (end-to-end), the unit may require removal of the compressor. Contact Trane or an agent of Trane specifically authorized to perform start-up and warranty of Trane® products regarding the disassembly and reassembly work. For more information, refer to [“Factory Warranty Information,” p. 3.](#)

Note: Disassembly and reassembly work includes dowel-pinning the compressor and removing it from the unit. Contact Trane or an agent of Trane specifically authorized to perform start-up and warranty of Trane® products for specific rigging instructions. Do NOT attempt to rotate the chiller onto its side.

- When lifting the chiller is either impractical or undesirable, attach cables or chains to the jacking slots shown in [Figure 4, p. 17](#); then push or pull the unit across a smooth surface. Should the chiller be on a shipping skid, it is not necessary to remove the skid from the chiller before moving it into place.
- If removal of the compressor or economizer assembly is necessary to move the chiller to the operating

location, contact Trane. For more information, refer to [“Factory Warranty Information,” p. 3.](#)

Unit Isolation

To minimize sound and vibration transmission through the building structure, and to ensure proper weight distribution over the mounting surface, always install isolation pads or spring isolators under the chiller feet.

Note: Isolation pads (see [Figure 5](#)) are provided with each chiller unless spring isolators are specified on the sales order.

Specific isolator loading data is provided in the unit submittal package. If necessary, contact your local Trane sales office for further information.

Important: When determining placement of isolation pads or spring isolators, remember that the control panel side of the unit is always designated as the unit front.

Isolation Pads

When the unit is ready for final placement, position isolation pads (18-in. sides) end for end under the full length of the chiller leg. The pads measure 6 in. × 18 in. (152.4 mm × 457.2 mm) and on some units there may be small gaps between pads. Pads are provided to cover entire foot.

Figure 5. Isolation pad and dimensions

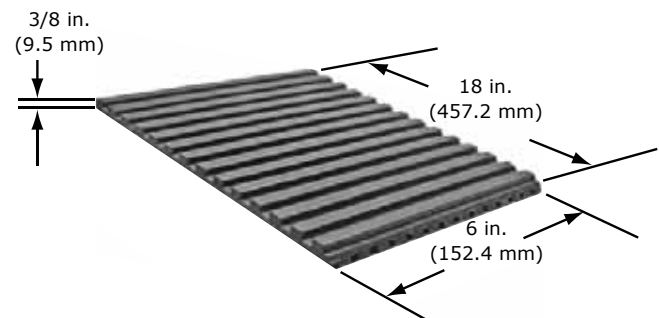

Remember that the chiller must be level within 1/16 in. (1.6 mm) over its length and width after it is lowered onto the isolation pads. In addition, all piping connected to the chiller must be properly isolated and supported so that it does not place any stress on the unit.

Spring Isolators

Spring isolators should be considered whenever chiller installation is planned for an upper story location. Base isolator placement is shown in [Figure 6.](#)

Figure 6. Isolation spring placement by shell size, evaporator and condenser length

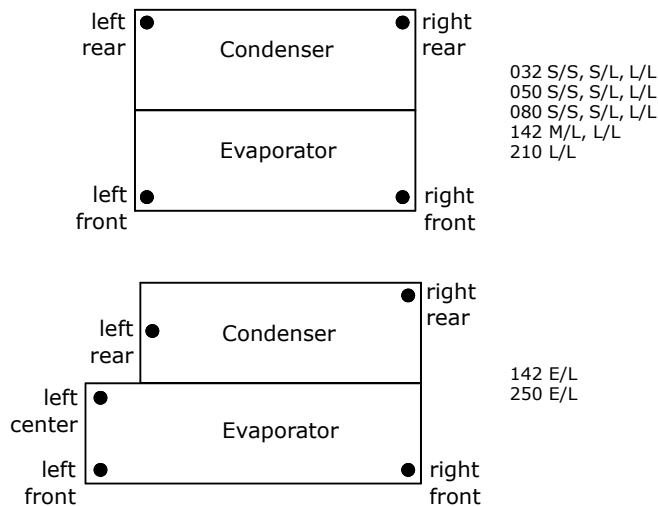

Spring isolators typically ship assembled and ready for installation. To install and adjust the isolators properly, follow the instructions given.

Note: Do not adjust the isolators until the chiller is piped and charged with refrigerant and water.

1. Position the spring isolators under the chiller as shown in [Figure 6](#). Ensure that each isolator is centered in relation to the tube sheet.

Note: Spring isolators shipped with the chiller may not be identical. Compare the data provided in the unit submittal package to determine proper isolator placement.

2. Set the isolators on the sub-base; shim as necessary to provide a flat, level surface at the same elevation for the end supports.

Important: Support the full underside of the isolator base plate; do NOT straddle gaps or small shims.

3. If required, bolt the isolators to the floor through the slots provided, or cement the pads.

Note: Fastening the isolators to the floor is not necessary unless specified.

4. If the chiller must be fastened to the isolators, insert capscrews through the chiller base and into holes drilled and tapped in the upper housing of each isolator.

Important: Do NOT allow the screws to protrude below the underside of the isolator upper housing, or interfere with the adjusting bolts. An alternative method of fastening the chiller to the isolators is to cement the neoprene pads.

5. Set the chiller on the isolators; refer to “[Standard Chiller Lift](#),” p. 16. The weight of the chiller will force

down the upper housing of each isolator, and could cause it to rest on the isolator’s lower housing (refer to [Figure 7](#)).

Figure 7. Chiller foot and isolator orientation

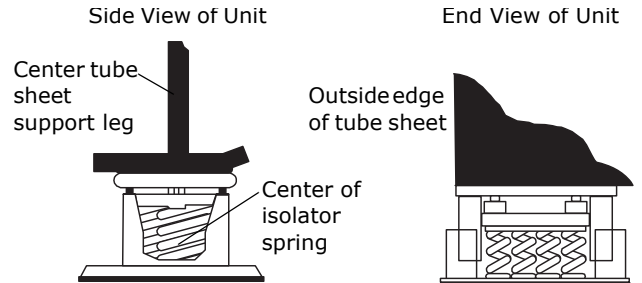

Note: The spring isolator must be centered in relation to the tube sheet. Do not align the isolator with the flat part of the chiller foot since the tube sheet is often off center

Note: The length of the isolator should be parallel to the leg.

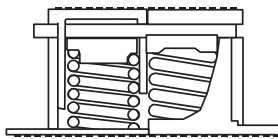
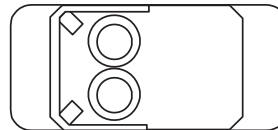

6. Check the clearance on each isolator. If this dimension is less than 1/4 in. (6.35 mm) on any isolator, use a wrench to turn the adjusting bolt one complete revolution upward.

Note: When the load is applied to the isolators (Step 5), the top plate of each isolator moves down to compress the springs until either the springs support the load or the top plate rests on the bottom housing of the isolator. If the springs are supporting the load, screwing down on the adjusting bolt (Step 7) will raise the chiller.

7. Turn the adjusting bolt on each of the remaining isolators to obtain the required minimum clearance of 1/4 in. (6.35 mm).

8. Once the minimum required clearance is obtained on each of the isolators, level the chiller by turning the adjusting bolt on each of the isolators on the low side of the unit. Work from one isolator to the next.

Important: The chiller must be level to within 1/16 in. (1.6 mm) over its length and width, and the clearance of each isolator must be at least 1/4 in. (6.35 mm).

Leveling the Unit

The chiller must be set level within 1/16 in. (1.6 mm).

1. Measure and make a punch mark an equal distance up from the bottom of each foot of the chiller.
2. Suspend a clear plastic tube along the length of the chiller as shown in the following figure.

3. Fill the tube with water until the level aligns with the punch mark at one end of the chiller.
4. Check the water level at the opposite mark. If the water level does not align with the punch mark, use full length shims to raise one end of the chiller until the water level at each end of the tube aligns with the punch marks at both ends of the chiller.
5. Once the unit is level across its length, repeat [Step 1](#) through [Step 3](#) to level the unit across its width.

Figure 8.

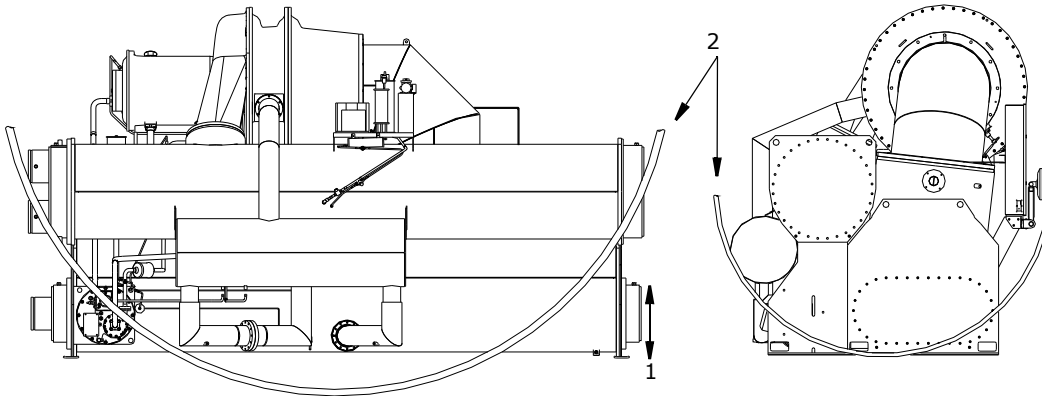

Note: Use of a laser level is an acceptable alternative method to level the unit.

Important: Immediately report any unit damage incurred during handling or installation at the job site to the Trane sales office.



Installation: Water Piping

Overview

The following water piping circuits must be installed and connected to the chiller:

- Pipe the evaporator into the chilled water circuit.
- Pipe the condenser into the cooling tower water circuit.
- *Optional:* A heat-recovery condenser water circuit.
- *Optional:* An auxiliary condenser water circuit.

Note: Piping must be arranged and supported to avoid stress on the equipment. It is strongly recommended that the piping contractor does not run pipe closer than 3 feet (0.91 m) minimum to the equipment. This will allow for proper fit upon arrival of the unit at the job site. Any adjustment that is necessary can be made to the piping at that time. Expenses that result from a failure to follow this recommendation will not be paid by Trane.

Piping suggestions for each of the water circuits listed above are outlined in “[Evaporator and Condenser Water Piping](#),” p. 23. General recommendations for the installation of field supplied piping components (e.g., valves, flow switches, etc.) common to most chiller water circuits are listed below.

Water Treatment

The use of untreated or improperly treated water in a CenTraVac may result in inefficient operation and possible tube damage.

Important: Trane strongly recommends using the services of a qualified water treatment specialist to determine necessary water treatment. A label with a customer disclaimer note is affixed to each unit.

NOTICE:

Proper Water Treatment!

Trane assumes no responsibility for equipment failures which result from untreated or improperly treated water, or saline or brackish water. The use of untreated or improperly treated water in a CenTraVac could result in scaling, erosion, corrosion, algae or slime. It is recommended that the services of a qualified water treatment specialist be engaged to determine what water treatment, if any, is required.

Pressure Gauges

Locate pressure gauge taps in a straight length of pipe. Place each tap a minimum of one pipe diameter downstream of any elbow, orifice, etc. For example, for a 6 in. (152.4 mm) pipe, the tap would be at least 6 in. (152.4 mm) from any elbow, orifice, etc.

Valves—Drains and Vents

NOTICE:

Waterbox Damage!

Failure to follow instructions could result in damage to the waterbox. Do not over-tighten or use excessive Teflon® pipe tape when installing valves, drains, plugs and vents on waterboxes.

1. Install field-supplied air vents and drain valves on the waterboxes. Each waterbox is provided with a National Pipe Thread Female (NPTF) vent and drain connection; depending on the waterbox types ordered, the openings may be 1/4 in. (6.35 mm), 1/2 in. (12.7 mm), or 3/4 in. (19.05 mm).

NOTICE:

Over-pressurization!

Failure to install pressure-relief valves in the condenser and evaporator water circuits could result in waterbox damage due to hydrostatic expansion.

2. If necessary for the application, install pressure-relief valves at the drain connections on the evaporator and condenser waterboxes. To do so, add a tee with the relief valve attached to the drain valve.

To determine whether or not pressure relief valves are needed for a specific application, keep in mind that:

- a. Vessels with close-coupled shutoff valves may cause high potentially damaging hydrostatic pressures as fluid temperature rises.
- b. Relief valves are required by American Society of Mechanical Engineers (ASME) codes when the shell waterside is ASME. Follow ASME guidelines or other applicable codes to ensure proper relief valve installation.

Strainers

NOTICE:

Tube Damage!

Failure to install strainers in all water piping entering the chiller could result in tube plugging conditions that damage unit components.

Install a strainer in the entering side of each piping circuit to avoid possible tube plugging in the chiller with debris.

Required Flow-Sensing Devices

Use flow paddle switches (see “[Paddle Switches](#),” p. 22), differential pressure switches or ifm efector® flow detection controller and sensor (see “[Water Flow](#)”).

Installation: Water Piping

Detection Controller and Sensor," p. 22) in conjunction with the pump interlocks to verify evaporator and condenser water flows.

To ensure adequate chiller protection, wire the chilled-water and condenser-water flow switches in series with the appropriate water pump interlock. Refer to the wiring diagrams that shipped with the unit for specific electrical connections.

Unless stated otherwise, all flow sensing devices must be field supplied. Be sure to follow the manufacturer's recommendations for device selection and installation (see Figure 9).

Also, review the following general flow switch installation guidelines.

Paddle Switches

Figure 9. Flow switch installation

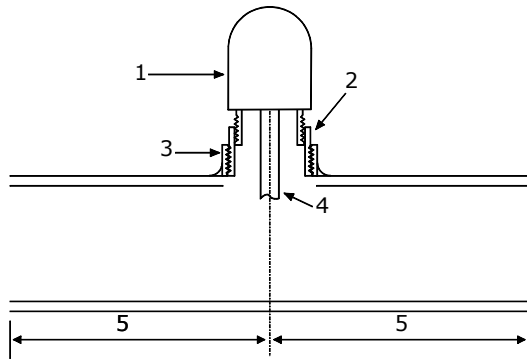

1. Flow switch body
2. One (1) pipe size larger bushing to avoid paddle interference
3. Pipe coupling
4. Flow switch paddle
5. Five (5) pipe diameters (no turns or fittings)

1. Mount the flow paddle switch upright in horizontal section of pipe. Allow at least five pipe diameters of straight, horizontal run on each side of the switch. Whenever possible, avoid locations adjacent to elbows, orifices, and valves.
2. To ensure that the flow switch operates as designed, adjust the length of the flow switch paddle to compensate for the pipe diameter and the height of the coupling used to install the switch.
3. Install the flow switch using a coupling that is large enough to allow the insertion of a bushing one pipe diameter larger than the flow switch base as shown in Figure 9. This will prevent interference with the flow switch paddle.
4. Verify that the direction-of-flow arrow on the switch points in the same direction as actual water flow through the piping circuit.
5. Remove all air from the piping circuit to prevent possible flow switch "fluttering".

6. Adjust the flow switch to open when water flow is less than normal.

Water Flow Detection Controller and Sensor

Figure 10. Installation of ifm effector flow detection controller and sensor

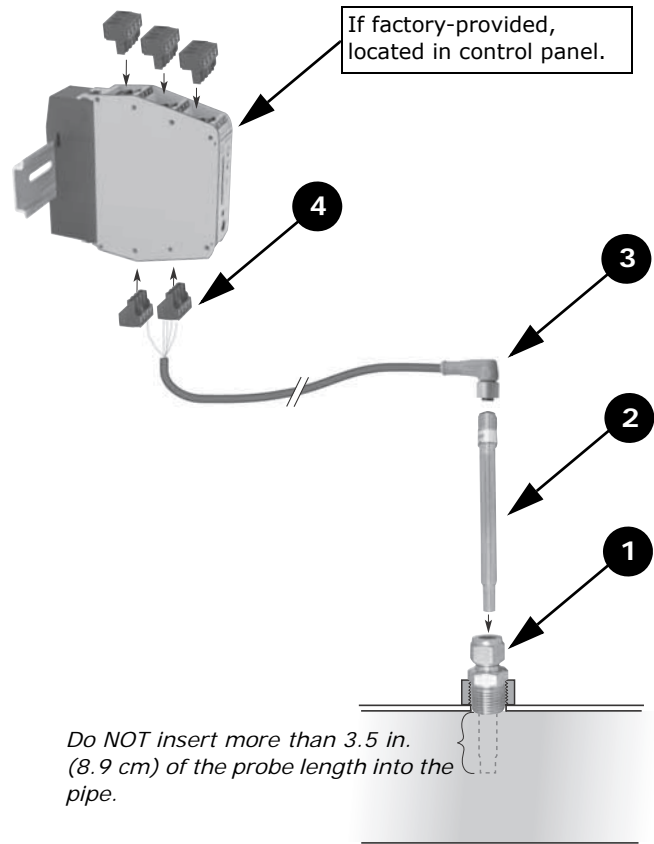

Do NOT insert more than 3.5 in. (8.9 cm) of the probe length into the pipe.

1. Mount the 1/2-in. NPT adapter in a horizontal or vertical section of pipe. The maximum distance from the control panel must not exceed 29.5 ft (8.99 meters) (see item labeled "1" in Figure 10, p. 22). Allow at least five pipe diameters straight run of pipe upstream of the sensor location, and three pipe diameters straight run of pipe downstream of the sensor location.
Note: In the case of a horizontal pipe, mounting the sensor in the side of the pipe is preferred. In the case of a vertical pipe, mounting the sensor in a place where the water flows upwards is preferred.
2. Insert the flow sensor probe (see item labeled "2" in Figure 10, p. 22) through the 1/2-in. NPT adapter so that 3–3.5 in. (7.6–8.9 cm) of the probe's length extends into the pipe. Finger-tighten the 1/2-in. NPT adapter; then, tighten with a wrench an additional 3/4 turns (minimum) to 1 turn (maximum); do NOT overtighten.

Note: When installed, the tip of the ifm efector sensor probe must be at least 1 in. (2.54 cm) away from any pipe wall. Do NOT insert more than 3.5 in. (8.9 cm) of the probe length into the pipe.

3. Install the Micro DC Cable by inserting it through the wire openings on the back side of the control panel (see item labeled "3" in Figure 10, p. 22). Install the supplied Micro DC Cable (9 meters [25 feet] in length) to the Flow Probe and hand-tighten the connector nut.
4. Plug the other end of the Micro DC Cable into the Flow Control Monitor with the Combicon connector (see item labeled "4" in Figure 10, p. 22). Refer to Figure 11 for cable wiring.

NOTICE:

Do Not Apply Electrical Power to a Unit in a Vacuum!

Failure to disconnect power to units with inside-the-delta solid state starters during evacuation or when the unit is in a deep vacuum could cause compressor motor damage. Applying electrical power to a motor in a vacuum could cause damage to the motor. In addition, on units with inside-the-delta solid state starters, all power to the unit must be disconnected prior to evacuating the unit as line power is directly applied to the motor terminals 4, 5, and 6.

5. Apply power to the chiller control panel to verify the Flow Control Monitor has power and the Low Volt Broken Wire Relay light is not lit.
6. Remove all air from the piping circuit prior to adjusting the low water flow setpoint.
7. Reduce the water flow to the minimum allowable flow and adjust the Flow setting on the Flow Control Monitor (see item labeled "7" in Figure 11). Adjusting the "Flow" potentiometer clockwise (+) reduces the flow setting cutout and adjusting counterclockwise (-) increases the flow setting cutout.

Note: The "Temp" potentiometer on the ifm efector control module has no effect in Trane application. It is not necessary to make adjustments to the "Temp" potentiometer.

8. Once the cutout setting is adjusted, the cutout setpoint will be indicated with a yellow light on the Flow Control Monitor LED bar graph display. When the water flows are higher than the cutout, a green light will indicate proper flow status. If the flows fall below the cutout setpoint, a red light will indicate low/no flow status.

Figure 11. ifm efector flow sensing device terminal connection

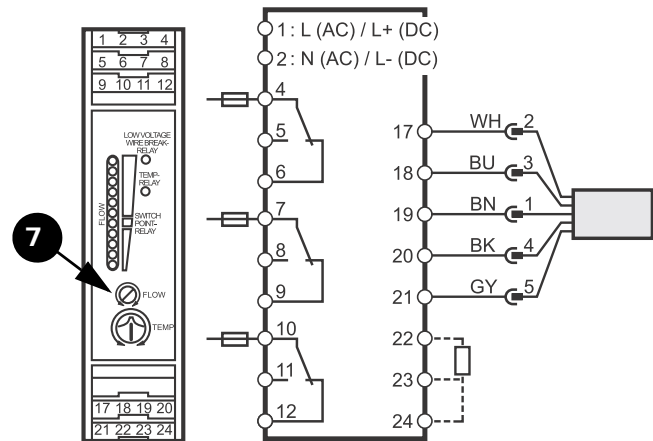

NOTICE:

Proof of Flow Switch!

Evaporator and condenser water circuits require proof of flow switches.

- Failure to include the proof of flow devices and/or jumping out these devices could cause the unit to stop on a secondary level of protection.
- Frequent cycling on these higher level diagnostic devices could cause excessive thermal and pressure cycling of unit components (O-rings, gaskets, sensors, motors, controls, etc.) and/or freeze damage, resulting in premature failure of the chiller.

Failure to provide flow switches or jumping-out of switches could result in severe equipment damage.

Evaporator and condenser proof of flow switches (either flow or Delta-P) are required as shown on wiring diagrams. These switches are used with control logic to confirm flow prior to starting a unit and to stop a running unit if flow is lost. For trouble shooting, a viewable diagnostic is generated if a proof of flow switch does not close when flow is required.

Evaporator and Condenser Water Piping

Figure 12 and Figure 13, p. 24 illustrate the recommended (typical) water piping arrangements for the evaporator and condenser.

Figure 12. Typical evaporator water piping circuit

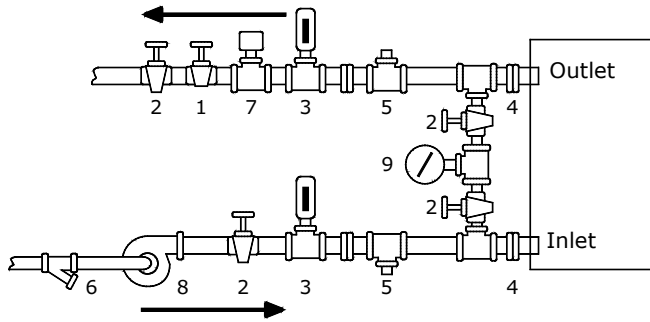

- | | |
|---|---|
| 1. Balancing Valve | 6. Strainer |
| 2. Gate (Isolation) Valve or Ball Valve | 7. Chilled Water Flow Switch (5S1) ^(a) |
| 3. Thermometer (if field supplied) | 8. Pump |
| 4. Waterbox Nozzle Connection | 9. Pressure Gauge ^(b) |
| 5. Drain, Vent, Anode | |

- (a) Flow switch 5S1 may be installed in either the entering or leaving leg of the chilled water circuit.
 (b) It is recommended to pipe the gauge between entering and leaving pipes. A shutoff valve on each side of the gauge allows the operator to read either entering or leaving water pressure.

Figure 13. Typical condenser water piping circuits

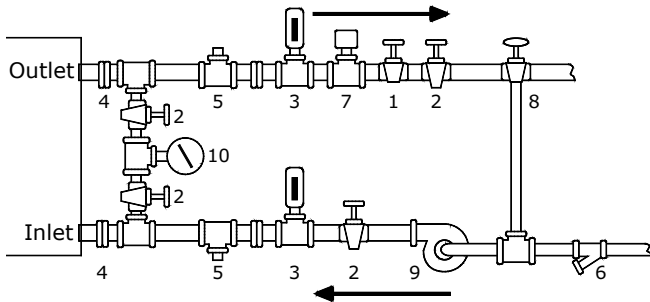

- | | |
|---|---|
| 1. Balancing Valve | 6. Strainer |
| 2. Gate (Isolation) Valve or Ball Valve | 7. Condenser Water Flow Switch (5S2) ^(a) |
| 3. Thermometer (if field supplied) | 8. 3-Way Valve (Optional) |
| 4. Waterbox Nozzle Connection | 9. Condenser Water Pump |
| 5. Drain, Vent, Anode | 10. Pressure Gauge ^(b) |

Notes:

- Some type of field-supplied temperature control device may be required to regulate the temperature of the heat-recovery condenser water circuit. For application recommendations, refer to *Heat Recovery Seminar (Part 2): "Systems/Equipment (AM-FND-8)*.
 - Install a bypass valve system to avoid circulating water through the auxiliary shell when the unit is shut down.
 - On multiple pass condensers, entering condenser water must enter at the lowest nozzle.
- (a) Flow switch 5S2 may be installed in either the entering or leaving leg of the chilled water circuit.
 (b) It is recommended to pipe a single gauge between entering and leaving pipes.

Piping must be arranged and supported to avoid stress on the equipment. It is strongly recommended that the piping contractor does not run pipe closer than 3 feet (0.91 meters) minimum to the equipment. This will allow for proper fit upon arrival of the unit at the job site. Any adjustment that is necessary can be made to the piping at

that time. Expenses that result from a failure to follow this recommendation will not be paid by Trane.

Water piping connection sizes and components are identified in [Table 3, p. 25](#), [Table 4, p. 25](#), and [Table 5, p. 26](#). Remember that with many waterboxes the entering and leaving evaporator water can be piped to either waterbox connection when the tube bundles are split vertically. However, large evaporator waterboxes, with entering and leaving connections not at the same level, must be connected with the entering water at the bottom and the leaving water at the top.

Waterboxes with multiple pass arrangements utilize a baffle to separate the passes. These baffles are designed for a maximum pressure of 20 psid (137.9 kPaD). If larger pressure drops are expected in the application, contact your local Trane representative to discuss special waterbox options.

Important: Water flows must be piped in accordance with nameplate designation.

Field-provided isolation valves for the evaporator and condenser water lines should be installed upstream and downstream of the heat exchangers, and be installed far enough away from the chiller to also provide practical service isolation for flow sensing devices, field thermometers, flexible connectors, and any removable pipe spools.

Ensure that the evaporator water piping is clear, check it after the chilled water pump is operated but before initial chiller start-up. If any partial blockages exist, they can be detected and removed to prevent possible tube damage resulting from evaporator freeze-up or erosion.

For condenser and large evaporator connections, arrange the water piping so that the water supply enters the shell at the lower connection, and exits from the top connection. Operational problems may result if this piping is not correct. Some shells may be piped as desired since both connections are at the same level.

For applications that include an "infinite source" or "multiple-use" cooling condenser water supply, install a valved bypass "leg" (optional) between the supply and return pipes. This valved bypass allows the operator to short-circuit water flow through the cooling condenser when the supply water temperature is too low. For additional application information, refer to *Engineering Bulletin: Condenser Water Temperature Control - For CenTraVac Centrifugal Chiller Systems with Tracer AdaptiView Controls (CTV-PRB006*-EN)*.

Note:

- System refrigerant pressure differential must be maintained above 3 psid (20.7 kPaD) at all times. Failure to do so could result in operating problems.
- Whenever a CVHE, CVHF, or CVHG unit is equipped with an auxiliary condenser, use a bypass valve system to avoid circulating water through the auxiliary shell during unit shut-down.

Water Piping Connections

All standard units use grooved-pipe connections. These are grooved-end NSP (Victaulic style) pipe connections. Flanged connections are optional.

Piping joined using grooved type couplings, like all types of piping systems, requires proper support to carry the weight of pipes and equipment. The support methods used must eliminate undue stresses on joints, piping and other components; allow movement where required, and provide for any other special requirements (i.e., drainage, etc.).

Note: Plug-type sensor extension cables are available for purchase from Trane Parts Service if needed. These sensor extension cables may be necessary if the waterboxes are changed or if the temperature sensors are moved out into the unit piping for better mixed temperature readings.

Table 3. Evaporator water piping connection sizes

EVSZ ^(a)	Nominal Pipe Size					
	1 Pass		2 Pass		3 Pass	
	in.	mm	in.	mm	in.	mm
032	8	219.1	6	168.3	5	141.3
050	10	273.0	8	219.1	6	168.3
080	12	323.9	10	273.0	8	219.1
142	16	406.4	12	323.9	10	273.0
210	16	406.4	14	355.6	12	323.9
250	16	406.4	14	355.6	12	323.9

(a) EVSZ = Evaporator Shell Size; S = Short Shell, L = Long Shell, E = Extended Shell

Table 4. Condenser water piping connection sizes

CDSZ ^(a)	Nominal Pipe Size	
	2 Pass	
	in.	mm
032	6	168.3
050	8	219.1
080	10	273.0
142	12	323.9
210	14	355.6
250	14	355.6

(a) CDSZ = Condenser Shell Size; S = Short Shell, L = Long Shell, E = Extended Shell

Figure 14. Typical grooved pipe connection

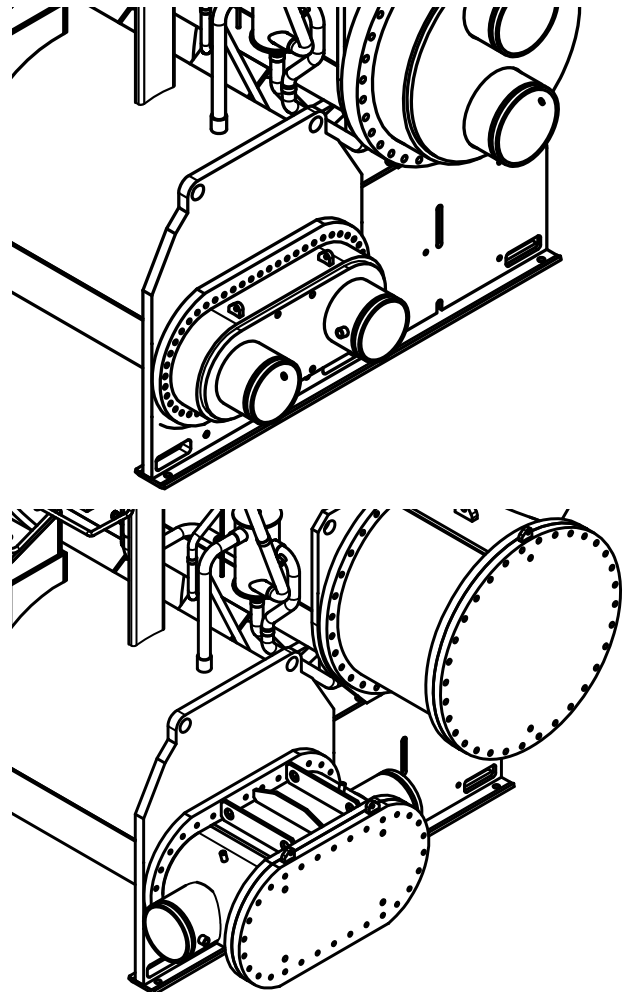

Waterbox Locations

NOTICE:

Do Not Exchange Positions of Marine-Style Waterboxes!

Failure to follow this instruction could alter designed water flow piping configuration and prevent proper unit operation. Contact CenTraVac Technical Service for switching of marine-style waterboxes.

If necessary, the non-marine-style waterboxes on each shell whether evaporator or condenser can be switched end-for-end to obtain the desired piping arrangement.

If removal of waterboxes is necessary, refer to [“Waterbox Removal and Installation,” p. 75.](#)

If the waterboxes on any of the shells are exchanged end-for-end, be sure to reinstall them right side up to maintain the correct baffle arrangements. Use a new gasket with each waterbox cover.

Grooved Pipe Coupling

A customer-supplied, standard flexible grooved pipe coupling (Victaulic Style 77 or equivalent) should be used to complete the Victaulic connection for both 150 psig or 1034.2 kPaG and 300 psig or 2068.4 kPaG waterboxes.

When a flexible coupling such as this is installed at the waterbox connections, other flexible piping connectors (i.e., braided-steel, elastomeric arch, etc.) are usually not required to attenuate vibration and/or prevent stress on the connections.

Table 5. Water piping connection components

Customer Piping Connection			
Unit Model	Unit Connection Type	Victaulic	Flanged
CVHE and CVHG	Flanged (Condenser 032-050 150 psig [1034.2 kPaG] non-marine only)	Customer provided	No adapter required
CVHE, CVHF, and CVHG	Victaulic (all others)	Victaulic coupling	Trane provided Victaulic-to-flange adapter

Figure 15. Customer piping connection types

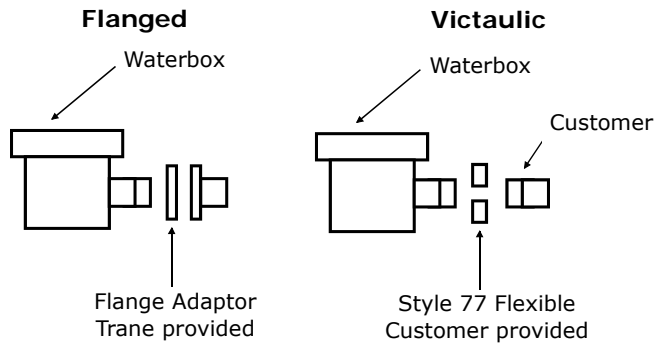

- Refer to the coupling manufacturer's guidelines for specific information concerning proper piping system design and construction methods for grooved water piping systems.
- Flexible coupling gaskets require proper lubrication before installation to provide a good seal. Refer to the coupling manufacturer's guidelines for proper lubricant type and application.

Flange-Connection Adapters

NOTICE:
Never Weld to Cast Boxes!
 Adapters must be used to convert flanges. Welding to cast boxes will result in equipment damage.

When flat-face flange connections are specified, flange-to-groove adapters are provided (Victaulic Style 741 for 150 psig or 1034.2 kPaG systems; Style 743 for 300 psig or

2068.4 kPaG systems). The adapters are shipped bolted to one of the chiller end-supports. Adapter descriptions are given in Table 6, p. 27 and Table 7, p. 27. The flange adapters provide a direct, rigid connection of flanged components to the grooved-pipe chiller waterbox connections.

Figure 16. Typical shipping location for flange

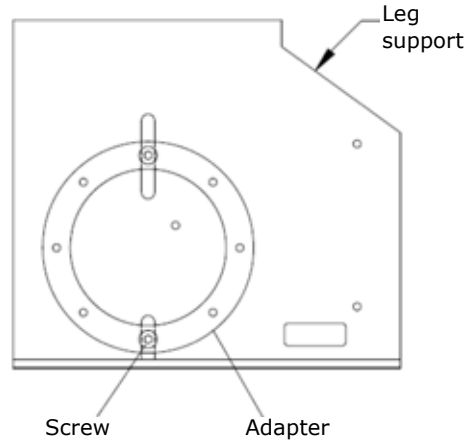

In this case, the use of flexible type connectors (i.e., braided steel, elastomeric arch, etc.) are recommended to attenuate vibration and prevent stress at the waterbox connections. Flange adapters are not provided for CVHE, CVHF, or CVHG units with 300 psig or 2068.4 kPaG waterboxes that have 14 in. (355.6 mm) and 16 in. (406.4 mm) piping connections.

All flange-to-flange assembly bolts must be provided by the installer. Bolt sizes and number required are given in Table 6, p. 27 and Table 7, p. 27. The four draw-bolts needed for the 14 in. (355.6 mm) and 16 in. (406.4 mm) Style 741 (150 psig or 1034.2 kPaG) adapters are provided. The Style 741, 150 psig or 1034.2 kPaG flange adapter requires a smooth, hard surface for a good seal.

Connection to other type flange faces (i.e., raised, serrated, rubber, etc.) will require the use of a flange washer between the faces. Refer to the flange adapter manufacturer's guidelines for specific information.

The Style 743 (300 psig or 2068.4 kPaG) flange adapters are designed to mate with raised-face flanges. They can be used with flat-faced flanges; however, only if the raised projections on the outside face of the adapter are removed; see Figure 17. The flange-adapter gasket must be placed with the color-coded lip on the pipe and the other lip facing the mating flange.

NOTICE:
Piping Connection Leaks!
 Failure to provide effective seal could result in equipment or property-only damage. To provide effective seal, gasket contact surfaces of adapter must be free of gouges, undulations or deformities.

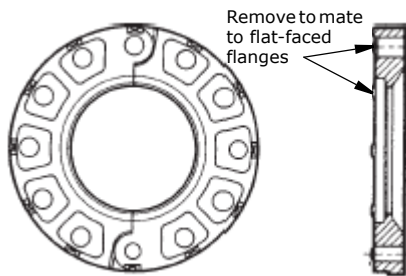
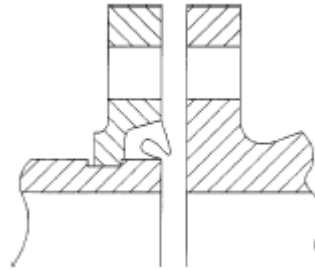
Figure 17. Modifying 300 psig flange adaptors for flat-faced flange application

Figure 18. Typical Victaulic flange gasket configuration

Victaulic Gasket Installation

1. Inspect supplied gasket to be certain it is suited for intended service (code identifies gasket grade). Apply a thin coat of silicone lubricant to gasket tips and outside of gasket.
2. Install gasket, placing gasket over pipe end and making sure gasket lip does not overhang pipe end. Refer to [Figure 18](#) for gasket configuration.
3. Align and bring two pipe ends together and slide gasket into position centered between the grooves on each pipe. No portion of the gasket should extend into the groove on either pipe.
4. Open fully and place hinged Victaulic flange around the grooved pipe end with the circular key section locating into the groove.
5. Insert a standard bolt through the mating holes of the Victaulic flange to secure the flange firmly in the groove.
6. Tighten fasteners alternately and equally until housing bolt pads are firmly together (metal to metal); refer to [“Bolt-Tightening Sequence for Water Piping Connections,” p. 28](#). Do not excessively tighten fasteners.

Note: Uneven tightening may cause gasket to pinch.

Table 6. Installation data for 150 psig flange adaptors (Style 741)

Nominal Pipe Size		Assembly Bolt Size ^(a)	Number of Assembly Bolts Required	Bolt Pattern Diameter		Weight	
in.	mm	in.		in.	mm	lb	kg
4	114.3	5/8 x 3	8	7.5	191	7.7	3.5
5	141.3	3/4 x 3-1/2	8	8.5	216	9.3	4.2
6	168.3	3/4 x 3-1/2	8	9.5	241	10.3	4.7
8	219.1	3/4 x 3-1/2	8	11.75	298	16.6	7.5
10	273.0	7/8 x	12	14.25	362	24.2	11.0
12	323.9	7/8 x 1/4	12	17	432	46.8	21.2
14	355.6	1 x 4-1/2	12	18.75	476	75	34.0
16	406.4	1 x 4-1/2	16	21.25	540	90	40.8

(a) Bolt size for conventional flange to flange connection. Longer bolts are required when flange washer must be used.

Table 7. Installation data for 350 psig flange adaptors (Style 743)

Nominal Pipe Size		Assembly Bolt Size ^(a)	Number of Assembly Bolts Required	Bolt Pattern Diameter		Weight	
in.	mm	in.		in.	mm	lb	kg
4	114.3	3/4 x 3-3/4	8	7.88	200	15.3	6.9
5	141.3	3/4 x 4	8	9.25	235	17.7	8.0
6	168.3	3/4 x 4-1/2	12	10.63	270	23.4	10.6
8	219.1	3/4 x 4-3/4	12	13	330	34.3	15.6
10	273.0	1 x 5-1/4	16	15.25	387	48.3	21.9
12	323.9	1-1/8 x 5-3/4	16	17.75	451	70.5	32.0

(a) Bolt size for conventional flange to flange connection. Longer bolts are required when flange washer must be used.

Bolt-Tightening Sequence for Water Piping Connections

This section describes a bolt-tightening sequence for flanges with flat gaskets or O-rings. Remember that improperly tightened flanges may leak.

Note: Before tightening any of the bolts, align the flanges. Flange bolt torque requirements are provided in Table 8.

Table 8. Flange bolt torque recommendations for O-ring and flat-gasket piping connections

Bolt Size		Gasket Type	
in.	mm	O-Ring ft·lb (N·m)	Flat ft·lb (N·m)
3/8	9.5	25 (34)	12-18 (16-24)
1/2	13	70 (95)	33-50 (45-68)
5/8	16	150 (203)	70-90 (95-122)
3/4	19	250 (339)	105-155 (142-210)

Note: Bolt size is determined by the diameter of bolt shank.

Flanges with 4, 8, or 12 Bolts

Tighten all bolts to a snug tightness, following the numerical sequence for the appropriate bolt pattern as shown below. Repeat this sequence to apply the final torque to each bolt.

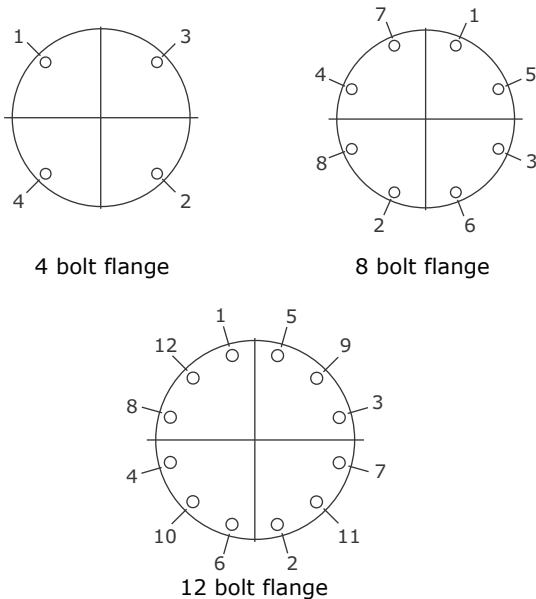

Flanges with 16, 20, or 24 Bolts

Tighten only the first half of the total number of bolts to a snug tightness, following the numerical sequence for the appropriate bolt pattern as shown below. Next, sequentially tighten the remaining half of the bolts in numerical order.

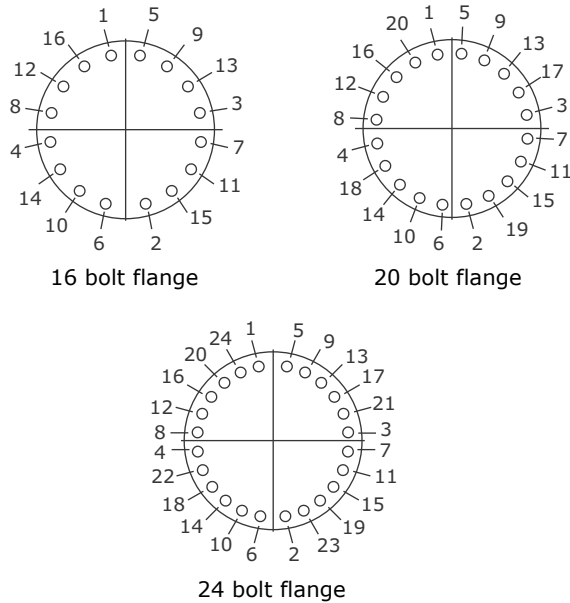

Flanges with More than 24 Bolts

Sequentially tighten the first 12 bolts to a snug tightness, following the numerical sequence as shown below. Tighten the next 12 consecutively numbered bolts in sequence to the final torque. Then, apply final torque to the first 12 bolts and the bolts not yet tightened (i.e., unnumbered bolts in the figure below). Start with bolt "1" and move progressively around the flange in a clockwise direction.

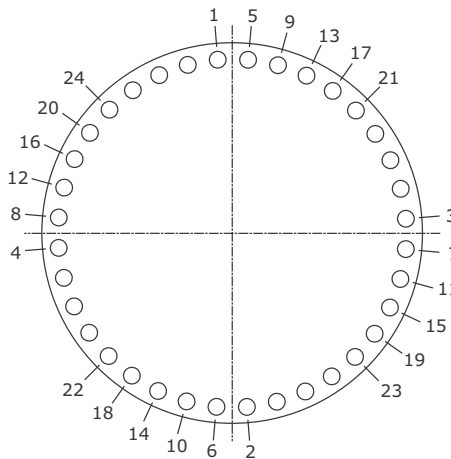

Evaporator Waterbox Covers

Ensure that the waterbox head rests tightly against the tube sheet, and then snugly tighten the 26 bolts in sequential order as shown in the figure below. If excessive tube sheet crown prevents the head from contacting the tube sheet, tighten the bolts located where the greatest gaps occur. Be sure to use an equal number of bolt turns from side to side. Then, apply final torque to each bolt in sequential order.

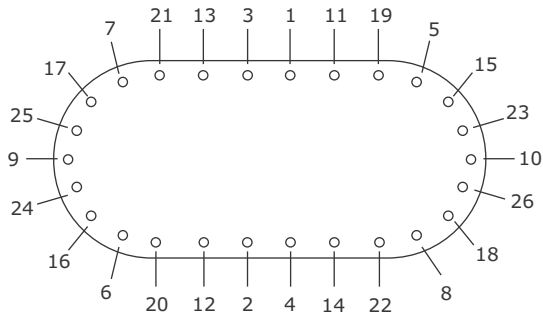

Pressure Testing Waterside Piping

NOTICE:

Equipment Damage!

Failure to follow these instructions could result in equipment damage. Do not over pressurize the system or exceed design pressure. Always perform as a hydro pressure test with water present in piping and waterboxes.

Waterside design pressure is either 150 or 300 psig (1034.2 or 2068.4 kPaG); refer to unit nameplate or to submittal documentation.



Vent Piping

Refrigerant Vent Line

General Requirements

State and local codes, and ASHRAE Standard 15 contain requirements for venting the relief device on the chiller to the atmosphere outside of the building. These requirements include, but are not limited to, permitted materials, sizing, and proper termination.

Note: The following information is a general outline of vent-line installation requirements based on ASHRAE Standard 15. Most codes contain similar requirements but may vary in some significant areas. The installer must check state and local codes and follow the specific requirements applicable to the location.

Purge Discharge

To comply with ASHRAE Standard 15, the discharge piping from purge units that remove noncondensable gas from refrigerating systems must conform to the ASHRAE Standard 15 requirements for relief piping. To help meet this requirement, the purge discharge is factory-piped to the relief device assembly.

Vent Line Materials

All materials in the relief device vent system must be compatible with the refrigerant in use. Commonly used and accepted piping materials include steel and DWV (drain/waste/vent) copper. Consult local codes for restrictions on materials. Consult with the manufacturers of any field-provided components or materials for acceptable material compatibility.

Note: PVC piping is compatible with R-123, but the glue that joins the sections of plastic pipe may not be. When considering a vent system constructed of plastic piping, such as PVC, ensure that both the pipe material and the adhesive have been tested for refrigerant compatibility. In addition, verify that the local codes permit PVC for refrigerant vent lines; even though ASHRAE Standard 15 doesn't prohibit its use, some local codes do.

Testing conducted in Trane laboratories has qualified the following materials for PVC pipe construction as being compatible with R-123:

Primer/Cleaner:

- Hercules—PVC Primer #60-465
- RECTORSEAL® PVC Cleaner—Sam™ CL-3L

Adhesives:

- Hercules—Clear PVC, Medium Body/Medium Set, #60-020
- RECTORSEAL—PVC Cement, Gene™ 404L

Flexible connection devices for vibration isolation must also be compatible with the vented refrigerant. A flexible

stainless-steel pump connector (such as the stainless-steel type MFP, style HNE, flexible pump connector from Vibration Mounting and Control, Inc.) or equivalent is recommended.

Vent Line Sizing

Vent line size must conform to local codes and requirements. In most cases, local codes are based on ASHRAE Standard 15. ASHRAE Standard 15 provides specific requirements for the discharge piping that allows pressure-relief devices to safely vent refrigerant to the atmosphere if over pressurization occurs. In part, the standard mandates that:

- The minimum pipe size of the vent line must equal the size of the discharge connection on the pressure-relief device. A larger vent line size may be necessary, depending on the length of the run.
- Two or more relief devices can be piped together *only if* the vent line is sized to handle all devices that could relieve at the same time.
- When two or more relief devices share a common vent line, the shared line must equal or exceed the sum of the outlet areas of all upstream relief devices, depending on the resulting back pressure.

ASHRAE Standard 15 provides guidance for determining the maximum vent line length. It also provides the equation (shown in [Figure 22, p. 34](#)) and data necessary to properly size the vent line at the outlet of a pressure-relief device or fusible plug.

The equation accounts for the relationship between pipe diameter, equivalent pipe length, and the pressure difference between the vent line inlet and outlet to help ensure that the vent line system provides sufficient flow capacity.

[Table 9, p. 33](#) provides additional information based on ASHRAE Standard 15, including:

- Capacities of various vent line sizes and lengths. However, this data applies only to conventional pressure-relief valves and NOT to balanced relief valves, rupture members (as used on Trane® centrifugal chillers), fusible plugs, or pilot-operated valves.
- A simplified method to determine the appropriate vent-line size, with [Figure 22, p. 34](#). Enter the figure with the total C value, read across to a pipe curve and down to find the maximum allowable length for that size pipe.

To determine the total C value for a specific unit, add the appropriate C values for the evaporator, standard condenser, and economizer. If the unit is equipped with any options (e.g., heat recovery, free cooling, or an auxiliary condenser), add the applicable C value(s) for those options to the total as well.

Note: [Table 9, p. 33](#) and [Figure 22, p. 34](#) are applicable only for non-manifolded vent-line runs connected

to a 15 psig (103.4 kPaG) rupture disk relief device. The pipe length provided by the table is in "equivalent feet." The vent-line length in equivalent feet is the sum of the linear pipe length plus the equivalent length of the fittings (e.g., elbows).

Vent Line Installation

Important: Before constructing the rupture disk vent line, consult local codes for applicable guidelines and constraints.

All CenTraVac centrifugal chillers are equipped with rupture disks. If refrigerant pressure within the evaporator exceeds 15 psig (103.4 kPaG) the rupture disk breaks and shell pressure is relieved as refrigerant escapes from the chiller.

A cross-section of the rupture disk assembly appears in [Figure 19, p. 32](#) along with an illustration indicating the location of the rupture disk on the suction elbow.

Important: If a RuptureGuard is to be installed, remove and discard the factory-installed rupture disk; for more information, refer to Installation, Operation, and Maintenance: RuptureGuard Pressure Relief System Option (CTV-SVX06*-EN, or the most recent version).

Several general recommendations for rupture disk vent line installation are outlined below.

Note: If the rupture disk was removed for service or vent line piping installation, the rupture disk must be reinstalled (as shown in [Figure 19, p. 32](#)). Refer to the following procedure and contact CenTraVac Technical Service when reinstalling the rupture disk.

- Verify that the vacuum support side of the rupture disk is positioned as shown in the cross-section view that appears in [Figure 19, p. 32](#).
 - Install the two bottom bolts through the pipe flanges.
 - Install the rupture disk with a gasket on each side between the pipe flanges. Orient the disk with the reference arrow or vacuum support bar facing the chiller side as shown in [Figure 19, p. 32](#).
 - Install the two top bolts.
 - Center the disk and gaskets to the flange bore.
 - Hand tighten all bolts assuring equal pressure.
 - Use a torque wrench set to 240 in-lb (27.1 N·m) with a 9/16-in. socket.
 - Tighten bolts in a star pattern, one half turn each, to maintain even pressure on the disk.
 - Final torque on all bolts should be 240 in-lb (27.1 N·m).
- When attaching the vent line to the chiller, do not apply threading torque to the outside pipe of the rupture disk assembly.

NOTICE:

Rupture Disk Damage!

Failure to follow instruction could result in damage to the rupture disk assembly. Do not apply threading torque to the outside pipe.

- Provide support as needed for the vent line. Do not use the rupture disk assembly to support the vent line piping.
- Use a flexible connection between the vent-line and the rupture disk assembly to avoid placing stress on the rupture disk. (Stress can alter rupture pressure and cause the disk to break prematurely.) The flexible connector used to isolate the rupture disk from excessive vent line vibration must be compatible with the refrigerant in use. Use a flexible, steel connector such as the stainless-steel type MFP, style HNE, flexible pump connector (from Vibration Mounting and Control, Inc.) or equivalent. Refer to [Figure 20, p. 32](#) for a recommended relief piping arrangement.
- An individual vent line is normally installed for each relief device. It is permissible to manifold the rupture disks of several machines into a common vent line provided that the appropriate ASHRAE Standards and local code requirements for manifolded relief devices are followed.

Note: [Figure 20, p. 32](#) does NOT apply for manifolded vent lines.

⚠ WARNING

Pressure-Relief Device Discharge Hazard!

An improper vent-line termination could result in death or serious injury or equipment damage. When a pressure-relief device operates, it could discharge a large amount of fluid and/or vapor. Units MUST be equipped with a vent-line termination that discharges outdoors in an area that will not spray refrigerant on anyone.

NOTICE:

Proper Refrigerant Vent Line Termination!

Failure to properly terminate a refrigerant vent line could result in equipment damage. Improperly terminating a refrigerant vent line could allow rain to enter the line. Accumulated rainwater could cause the relief device to malfunction; or, in the case of a rupture disk, the rainwater pressure could cause the disk to rupture, allowing water to enter the chiller.

- Route the vent-line piping so that it discharges outdoors in an area that will not spray refrigerant on anyone. Position the vent line discharge at least 15 feet (4.572 meters) above grade level and at least 20 feet (6.096 meters) from any building opening. Provide a vent line termination that cannot be blocked by debris or accumulate rainwater.

- Provide a drip leg on the vent-line (see [Figure 20, p. 32](#)). Provide a standard 1/4-in. FL x 1/4-in. NPT, capped refrigerant service valve to facilitate liquid removal.

NOTICE:
Equipment Damage!
 Trane assumes no responsibility for equipment damage caused by insufficient drainage of the drip leg. All vent-lines must be equipped with a drip leg of sufficient volume to hold the expected accumulation of water and or refrigerant. The drip leg must be drained periodically to ensure that it does not overflow and allow fluid to flow into the horizontal portion of the vent-line.

- Consult local regulations and codes for any additional relief line requirements and refer to *Refrigerant Handling Guidelines* (CTV-SVX05*-EN, or the most recent version).

Figure 19. Illustrates rupture disk location, cross section of rupture disk

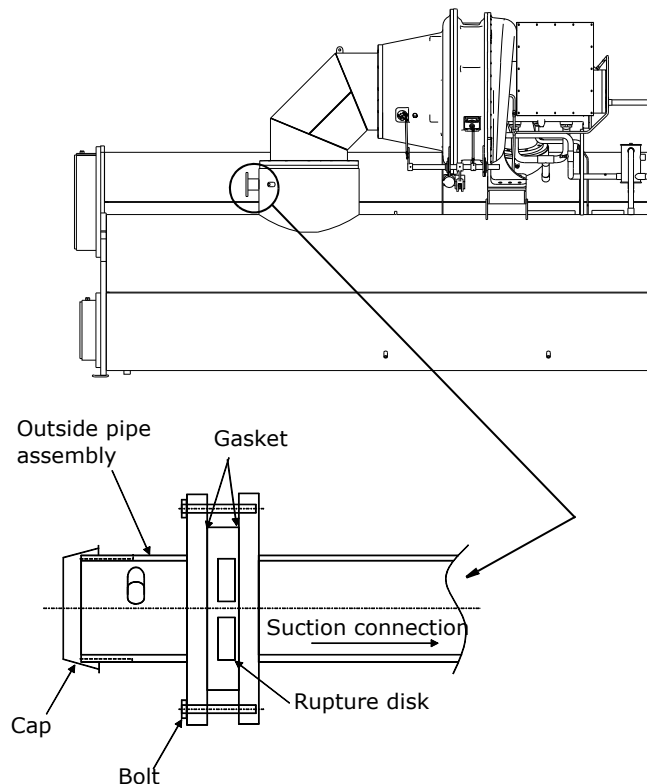

Note: Pipe connection is 3 in. NPT, except 250E evap/250L cond units with heat recovery which have a 4 in. NPT pipe connection.

Figure 20. Arrangement for rupture disk relief piping

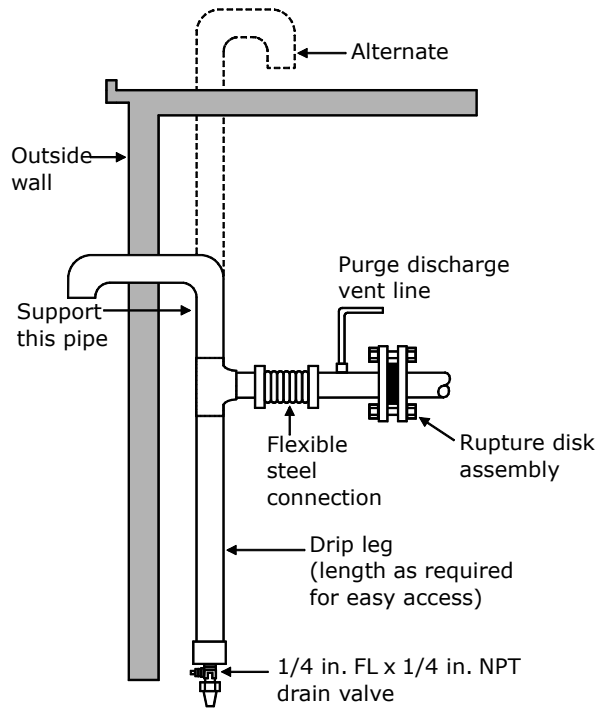

Notes:

- If a RuptureGuard is to be installed, remove and discard the factory-installed rupture disk; for more information, refer to Installation, Operation, and Maintenance: RuptureGuard Pressure Relief System Option (CTV-SVX06*-EN, or the most recent version).
- The rated flow capacity of the RuptureGuard disk/valve assembly is based on having straight pipe extending past the spring mechanism downstream of the valve. Be sure there are no crosses¹, elbows, tees or any other obstructions within the first nine inches of valve discharge. Refer to ASHRAE Standard 15 for additional requirements on piping rupture disk and relief valve vent lines.

¹ A derate on the rated flow capacity for this configuration is published in E/CTV-EB-10 (*Engineering Bulletin: RuptureGuard™ Selection Guide*).

Figure 21. RuptureGuard—external vent line and drip leg (not provided)

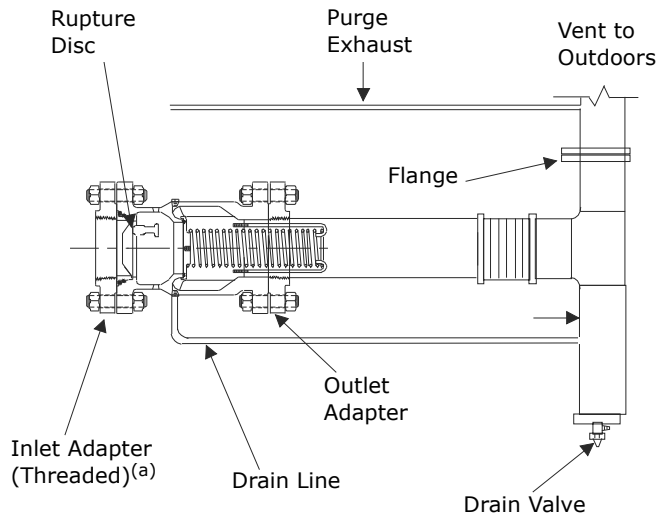

(a) The pipe-thread joint at the Inlet Adapter (Threaded) connects to the chiller and must be leak-free. For more information, refer to *Installation, Operation, and Maintenance: RuptureGuard Pressure Relief System Option* (CTV-SVX06*-EN, or the most recent version).

Table 9. "C" values used to determine rupture disk vent line sizes

Evap. Size (EVSZ)	Cond. Size (CDSZ)	"C" Values for Unit Components				
		Total "C" Value	Short H.R. Cond.	Long H.R. Cond.	Aux. Cond.	W/Free Cooling Econ.
032S	032S	50.00				
032S	032L	61.32	18.87	25.19	15.30	3.66
032L	032L	65.09				
050S	050S	64.20				
050S	050L	72.10	23.55	31.45	15.30	5.50
050L	050L	83.17				
050S	080S	69.71	N/A	N/A	N/A	N/A
050L	080L	90.52				
080S	080S	86.48				
080S	080L	96.22	29.06	38.80	15.30	5.38
080L	080L	111.50				
080L	142L	117.53	N/A	N/A	N/A	N/A
142M	142L	127.49				
142L	142L	134.89				
142E	142L	143.11	51.01	56.80	15.30	7.13
210L	210L	149.91				
250E	250L	175.74	N/A	62.12	15.30	N/A
210D	210D	112.93				
250D	250D	122.62			15.30	7.13
250M	250M	146.36	N/A	N/A		
250X	250X	164.74			15.30	N/A

Notes:

- Rupture disk diameter is 3 inches (76.2 mm), with the exception of 250E evap/250L cond units with heat recovery which have a rupture disk diameter of 4 inches (101.6 mm).
- To determine the total "C" value for a specific unit, add the appropriate "C" values for the evaporator standard condenser, and economizer. If the unit is equipped with any options (e.g., heat recovery, free cooling or an auxiliary condenser, add the applicable "C" values to this total. With this new sum, refer to [Figure 22, p. 34](#) to determine the vent line pipe diameter.
- If piping multiple rupture disks to a common vent line, first determine the total "C" value for each rupture disk, then add all "C" values together and apply the result to [Figure 22, p. 34](#).
RuptureGuard size based on "C" value:
3-in. (76.2 mm) valve: "C" value 0 to 104.20
4-in. (101.6 mm) valve: C value 104.21 to 223.9
RuptureGuard is not available for 250E evap/250L cond units with heat recovery.

$$L = \frac{0.214d^5 (P_2^2 - P_1^2)}{fC_R^2} - \frac{d * \ln(P_0 / P_2)}{6f}$$

For CenTraVac chillers using a rupture disk relief:

- L = equivalent length of discharge piping, feet (meters)
- C_R = rated capacity as stamped on the relief device in lb/min (kg/s), or SCFM multiplied by 0.0764 lb/min (convert multiplier in lb/min to kg/s for SI)
 C_R = C value from [Table 9, p. 33](#) (convert C in lb/min to kg/s for SI)
- f = Moody friction factor in fully turbulent flow
- d = inside diameter of pipe or tube, in (mm)

Vent Piping

- \ln = natural logarithm
- P_2 = absolute pressure at outlet of discharge piping, psi (kPa)
- P_0 = allowed back pressure (absolute) at the outlet of pressure relief device, psi (kPa)

$$P_0 = (0.50 P) + \text{atmospheric pressure}$$

Note: For rupture disks on CenTraVac chillers, P is 15 lb. Atmospheric pressure is at the elevation of the installation above sea level; a default value is the atmospheric pressure at sea level, 14.7 psi (101.34 kPa).

Figure 22. Rupture disk vent pipe sizing

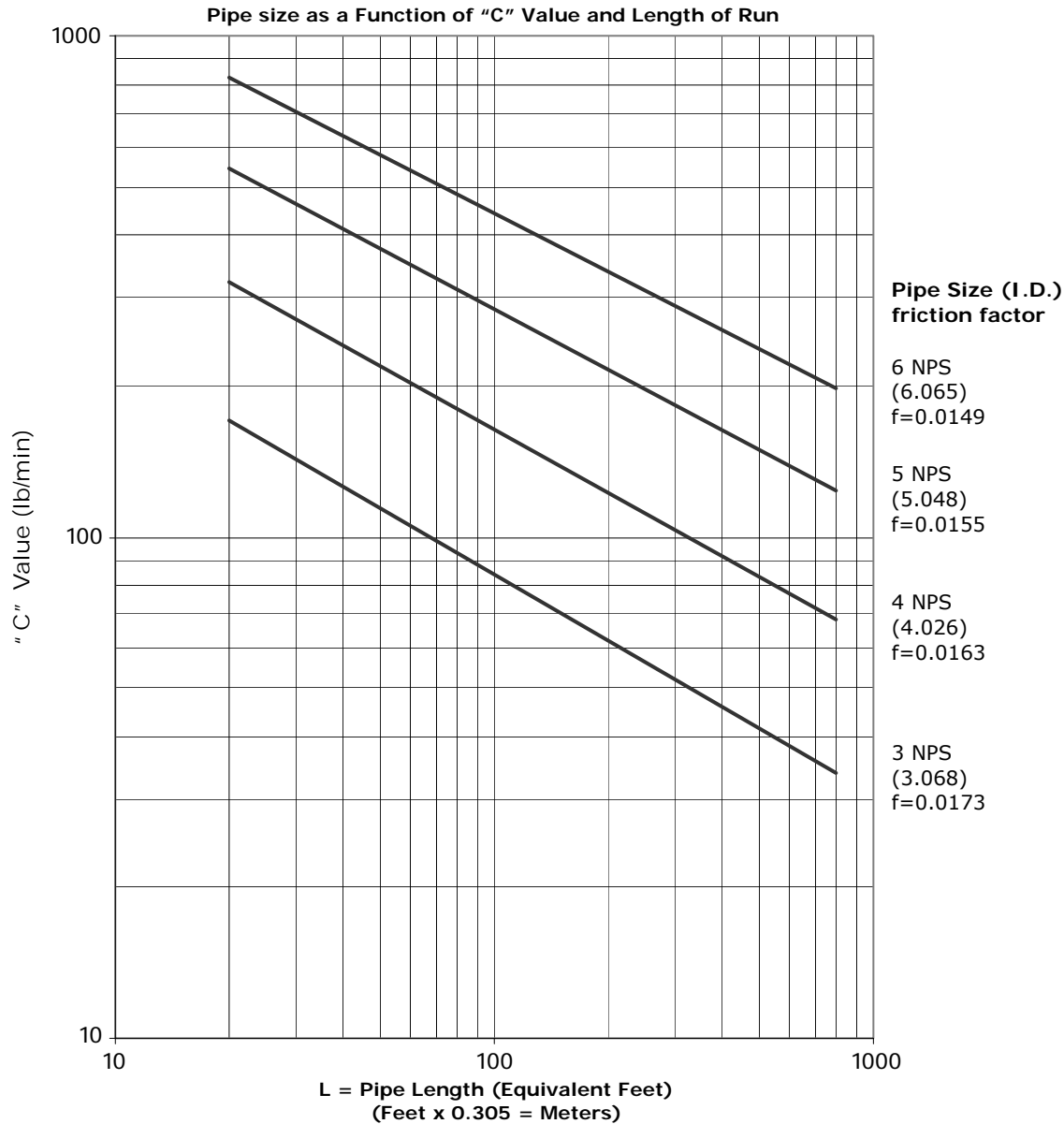

ASHRAE Standard 15

$$L = \frac{0.214d^5 (P_0^2 - P_2^2)}{fC^2R} - \frac{d \cdot \ln(P_0 / P_2)}{6f}$$

$$P_0 = (0.5 \cdot 15) + P_2$$

$$P_2 = 14.7 \text{ psia}$$

f = Moody Friction Factor in fully turbulent flow

Note: This figure, provided as a reference, is based on ASHRAE Standard 15. Vent line size is typically dictated by state or local code which may be different from ASHRAE Standard 15 requirements.



Insulation

Unit Insulation Requirements

Factory-installed insulation is available as an option for all units. Factory installation does not include insulation of the chiller feet; if required, insulation for chiller feet is provided by others. In applications where the chiller is not factory-insulated, install insulation over the areas outlined and highlighted with dashed lines as shown in [Figure 23, p. 36](#).

Insulate all 1/4-in. (6.35-mm) eductor lines, one from the suction cover and one from the evaporator to prevent sweating.

The quantities of insulation required based on unit size and insulation thickness are listed in [Table 10](#). Insulation thickness is determined at normal design conditions which are:

- standard comfort-cooling leaving chilled water temperature
- 85°F (29.4°C) dry bulb ambient temperature
- 75 percent relative humidity

Operation outside of normal design conditions as defined above may require additional insulation; contact Trane for further review.

Note: If the unit is not factory-insulated: install insulation around the evaporator bulbwells and ensure that the bulbwells and connections for the waterbox drains and vents are still accessible after insulation is applied. The sensor modules (LLIDs) and interconnecting four wire cable (IPC bus) must be raised up above the field-installed insulation. Secure the IPC bus to the insulation top/outer surface after insulation is completed.

Important: Do not insulate the motor housing, unit wiring, or sensor modules.

NOTICE:

Equipment Damage!
 Failure to remove the strain relief with the sensor could result in equipment damage. Do NOT attempt to pull sensor bulb through the strain relief; always remove the entire strain relief with the sensor.

Table 10. Evaporator insulation requirements

EVSZ ^(a)	Standard Unit		Free Cooling	
	3/4 in. (19.05 mm) Insulation ^(a) (Square Feet)	3/8 in. (9.525 mm) Insulation ^(b) (Square Feet)	3/4-in. (19.05 mm) Insulation ^(a) (Square Feet)	3/8 in. (9.525 mm) Insulation ^(b) (Square Feet)
032 Short	337	52	347	74
032 Long	365	52	377	74
050 Short	385	63	398	72
050 Long	420	63	436	72
080 Short	505	84	515	97
080 Long	553	84	566	97
142 Medium	555	98	555	133
142 Long	578	98	578	133
142 Extended	603	104	629	133
210 Long	700	98	710	133
250 Extended	770	97	780	133

Note: Refrigerant pump equipped units are NOT insulated on the motor or refrigerant drain lines.

(a) 3/4-in. (19.05-mm) sheet insulation is installed on the evaporator, evaporator waterboxes, suction elbow and suction cover.

(b) 3/8-in. (9.525-mm) sheet insulation is installed on all economizers. All liquid lines and other pipes require the use of 1/2-in. (12.7-mm) pipe insulation or 3/8-in. (9.525-mm) sheet insulation. Copper oil eductor tube lines require pipe insulation.

Insulation Thickness Requirements

Factory applied insulation. All low-temperature surfaces are covered with 3/4 in. (19.05 mm) Armaflex[®] II or equal (thermal conductivity = 0.28 Btu/h-ft² [1.59 W/m²-K]), including the evaporator, waterboxes and suction elbow. The economizer and motor cooling lines are insulated with 3/8 in. (9.525 mm) and 1/2 in. (12.7 mm) insulation respectively.

The insulation is Armaflex or equivalent closed cell elastomeric insulation to prevent the formation of condensation up to a dew point rating of 74°F K = 0.25. Chillers in high humidity areas or ice storage, low leaving water temperature (less than 36°F [2.2°C] chilled water temperature/glycol) units may require double thickness to prevent formation of condensation.

NOTICE:

Insulation Damage!

To prevent damage to factory installed insulation:

- Do not allow the insulation to be exposed to excessive sunlight. Store indoors or cover with canvas to prevent exposure.
- Do not use thinners and solvents or other types of paint. Use only water base latex.

Failure to follow these instructions could result in insulation damage.

Figure 23. Recommended area for unit insulation

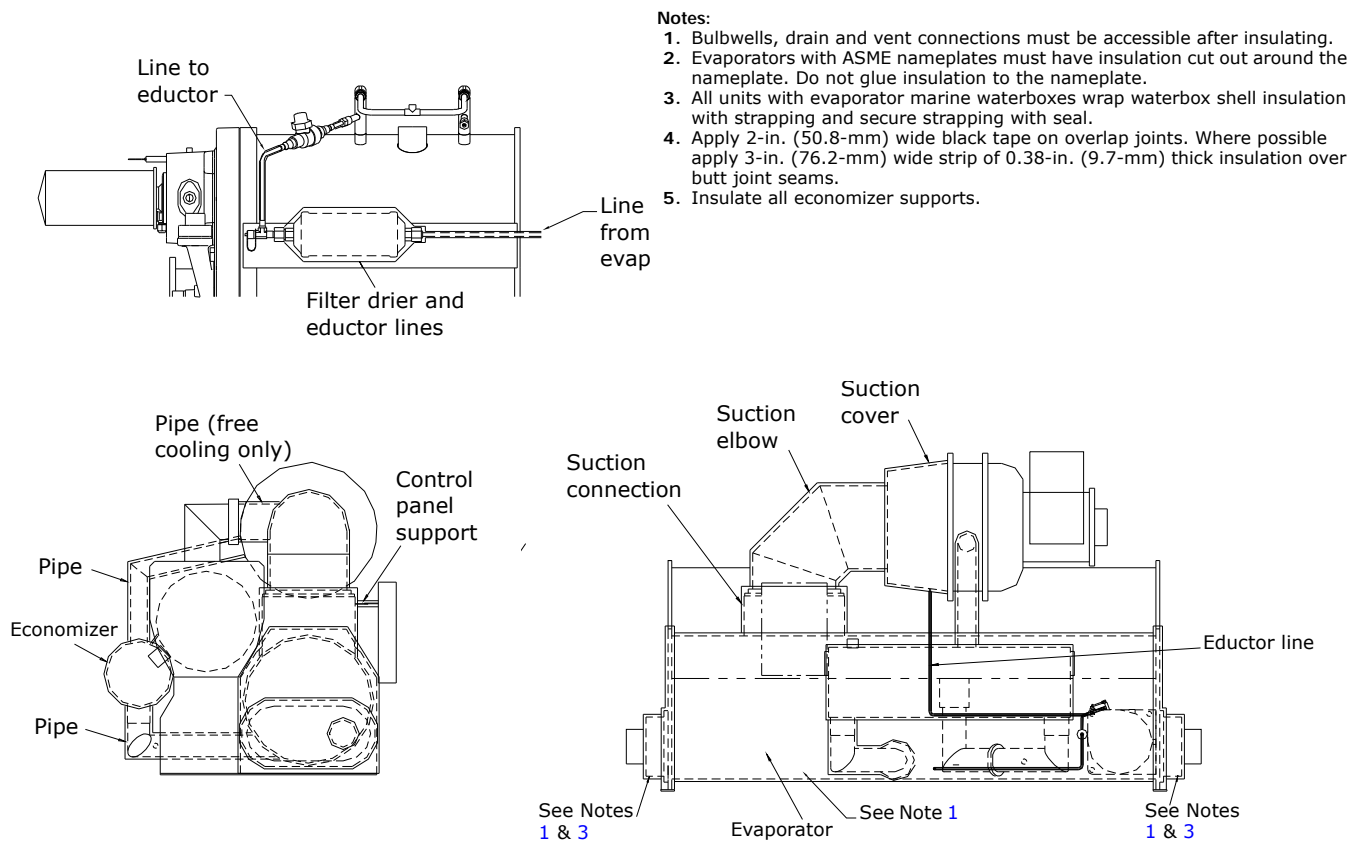

Installation: Controls

This section covers information pertaining to the UC800 controller hardware. For information about the Tracer AdaptiView™ display, which is used to interface with the internal chiller data and functions provided by the UC800, refer to *Tracer AdaptiView™ Display for Water-Cooled CenTraVac™ Chillers Operations Guide* (CTV-SVU01*-EN, or the most recent version).

UC800 Specifications

Power Supply

The UC800 (1A22) receives 24 Vac (210 mA) power from the 1A2 power supply located in the chiller control panel.

Wiring and Port Descriptions

Figure 24 illustrates the UC800 controller ports, LEDs, rotary switches, and wiring terminals. The numbered list following Figure 24 corresponds to the numbered callouts in the illustration.

Figure 24. Wiring locations and connection ports

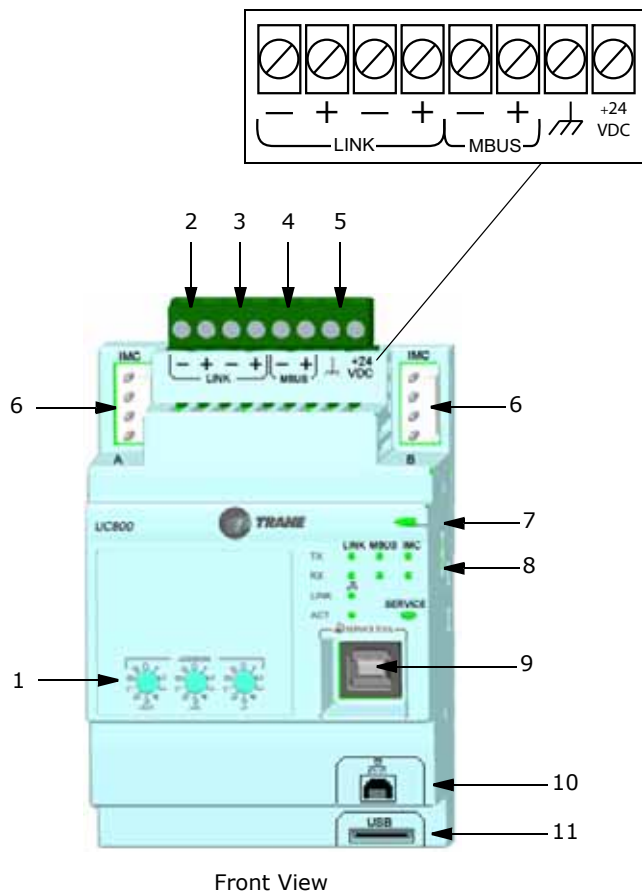
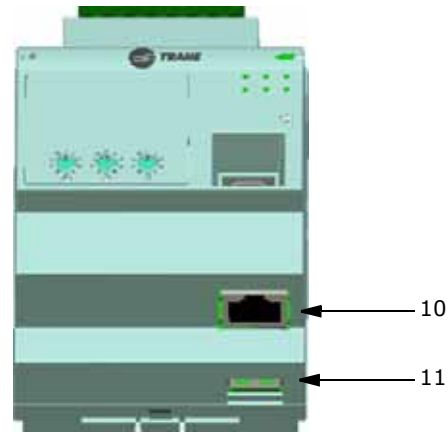

Figure 24. Wiring locations and connection ports



Bottom View

1. Rotary Switches for setting BACnet® MAC address or MODBUS® ID.
2. LINK for BACnet MS/TP, or MODBUS Slave (two terminals, ±). Field wired if used.
3. LINK for BACnet MS/TP, or MODBUS Slave (two terminals, ±). Field wired if used.
4. Machine bus for existing machine LLIDs (IPC3 Tracer bus 19.200 baud). *IPC3 Bus: used for Comm4 using TCI or LonTalk® using LCI-C.*
5. Power (210 mA at 24 Vdc) and ground terminations (same bus as item 4). Factory wired.
6. Not used.
7. Marquee LED power and UC800 Status indicator (Table 11, p. 38).
8. Status LEDs for the BAS link, MBus link, and IMC link.
9. USB device type B connection for the service tool (Tracer TU).
10. The Ethernet connection can *only* be used with the Tracer AdaptiView display.
11. USB Host (not used).

Communication Interfaces

There are four connections on the UC800 that support the communication interfaces listed. Refer to Figure 24, p. 37 for the locations of each of these ports.

- BACnet MS/TP
- MODBUS Slave
- LonTalk using LCI-C (from the IPC3 bus)
- Comm 4 using TCI (from the IPC3 bus)

Rotary Switches

There are three rotary switches on the front of the UC800 controller. Use these switches to define a three-digit address when the UC800 is installed in a BACnet or MODBUS system (e.g., 107, 127, etc.).

Note: Valid addresses are 001 to 127 for BACnet and 001 to 247 for MODBUS.

LED Description and Operation

There are 10 LEDs on the front of the UC800. Figure 25 shows the locations of each LED and Table 11, p. 38 describes their behavior in specific instances.

Figure 25. LED locations

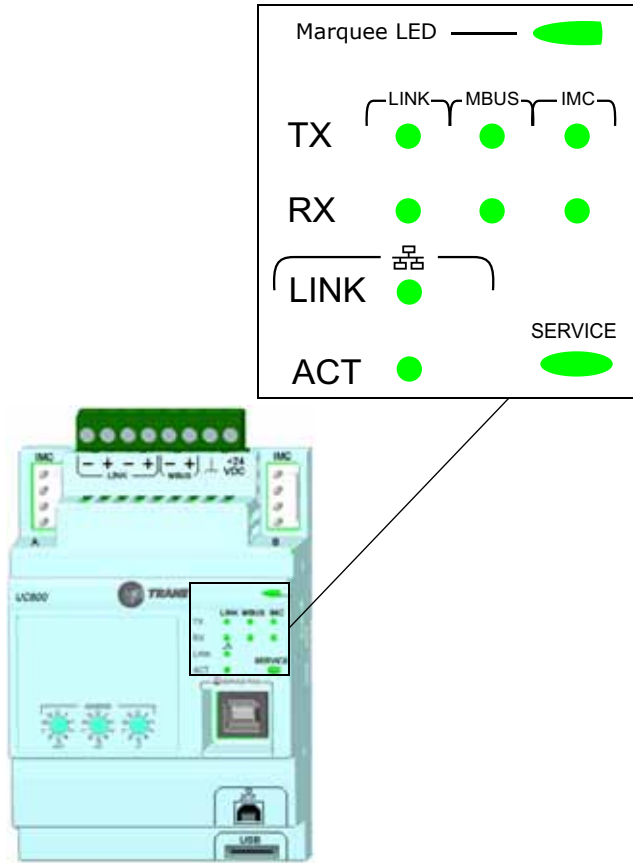
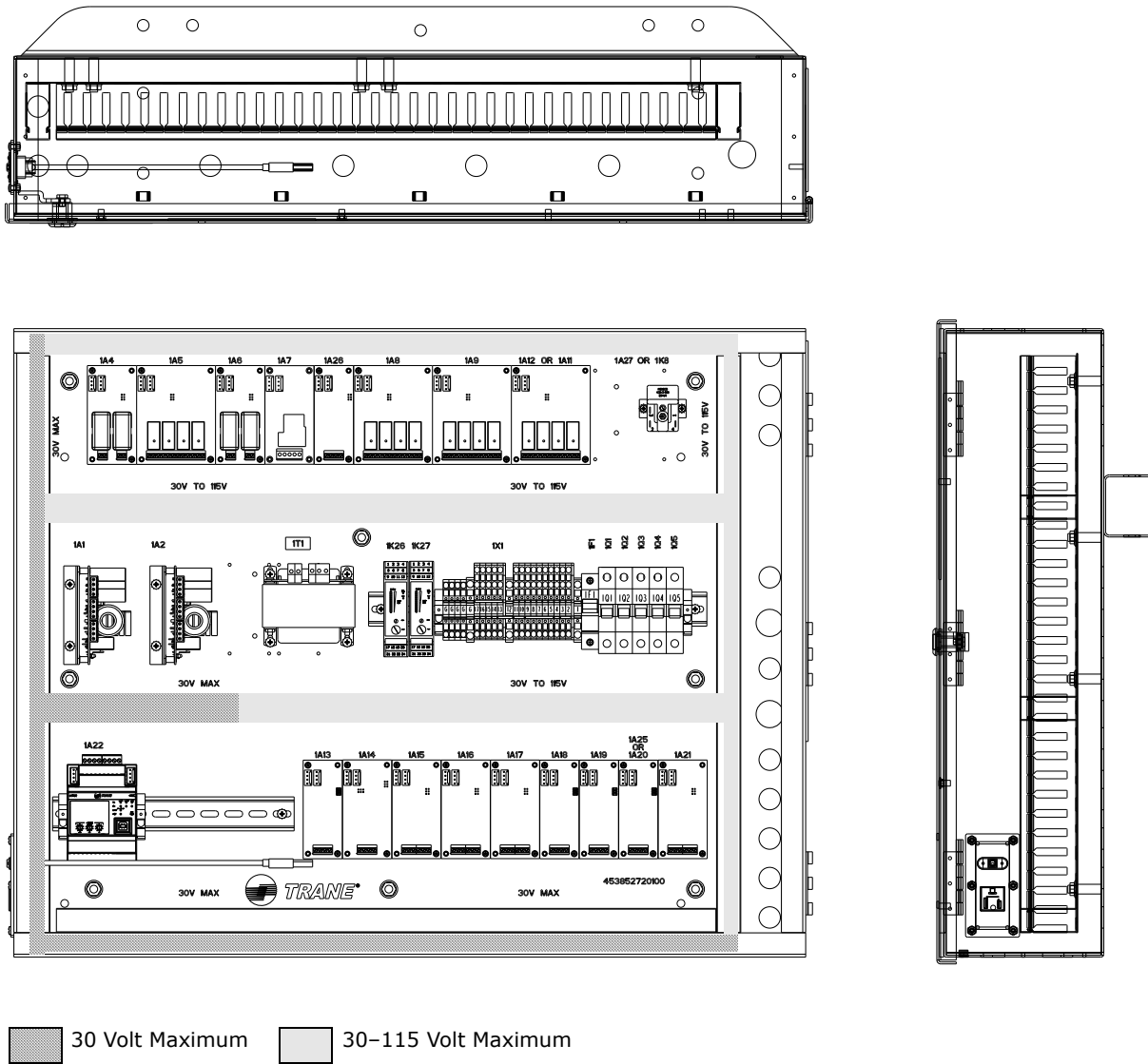

Table 11. LED behavior

LED	UC800 Status
Marquee LED	Powered. If the Marquee LED is green solid, the UC800 is powered and no problems exist.
	Low power or malfunction. If the Marquee LED is red solid, the UC800 is powered, but there are problems present.
	Alarm. The Marquee LED blinks Red when an alarm exists.
LINK, MBUS, IMC	The TX LED blinks green at the data transfer rate when the UC800 transfers data to other devices on the link.
	The Rx LED blinks yellow at the data transfer rate when the UC800 receives data from other devices on the link.
Ethernet Link	The LINK LED is solid green if the Ethernet link is connected and communicating.
	The ACT LED blinks yellow at the data transfer rate when data flow is active on the link.
Service	The Service LED is solid green when pressed. For qualified service technicians only. Do not use.

Important: Maintain at least 6 in. (16 cm) between low-voltage (<30V) and high voltage circuits. Failure to do so could result in electrical noise that could distort the signals carried by the low-voltage wiring, including IPC.

Figure 26. Standard control panel: Tracer AdaptiView main unit assembly (showing low voltage and higher voltage areas for proper routing of field wiring)





Installation: Controls

Figure 27. Optional control panel: Tracer AdaptiView main unit assembly (showing low voltage and higher voltage areas for proper routing of field wiring)

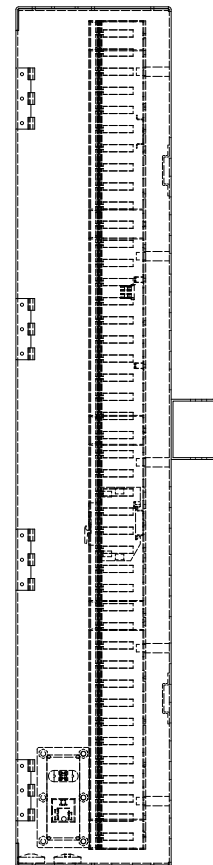
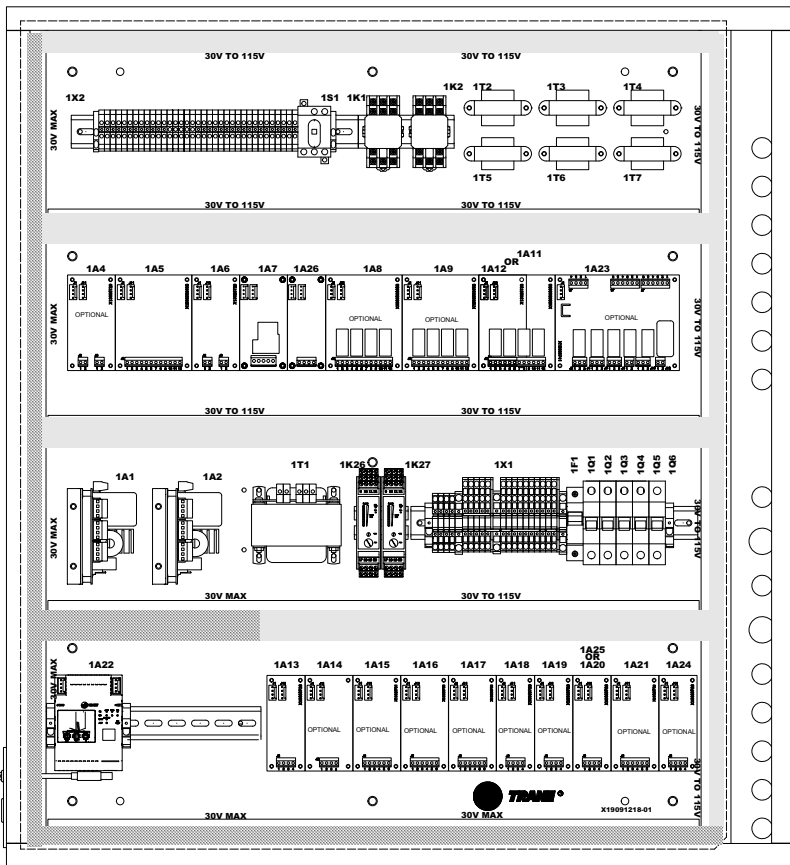
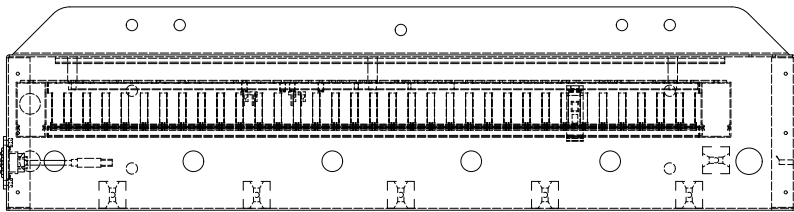

 30 Volt Maximum  30-115 Volt Maximum

Installing the Tracer AdaptiView Display

The Tracer AdaptiView display is boxed, shrink-wrapped, and located behind the control panel during shipment. The Tracer AdaptiView display must be installed at the site.

Important: The Tracer AdaptiView display and display arm are to be installed by Trane, or an agent of Trane, for best results.

1. Unwrap the control panel and display arm. Locate the box containing the Tracer AdaptiView display behind the control panel (labeled A).
2. After the box containing the display has been removed, remove the shipping bracket from the back of the control panel (B).

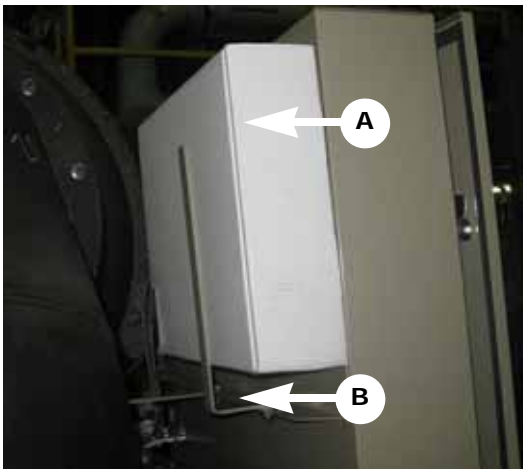

3. Remove the Tracer AdaptiView display from the box.
Note: Screws are M4 (metric size 4), 6 to 8 mm long, and are shipped with the display.
4. Plug the power cable (C) and the Ethernet cable (D) into the bottom of the display.
Note: Both cables are already present and extend from the end of the display arm.

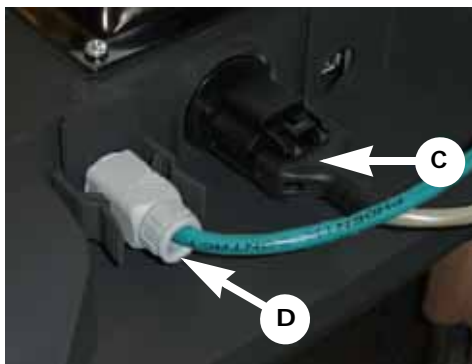

5. Adjust the Tracer AdaptiView display support arm so the base plate that attaches to the Tracer AdaptiView display is horizontal.

⚠ CAUTION

Tension in Display Support Arm!

Failure to ensure that the support arm is in the full upright position when removing the Tracer AdaptiView display from the support arm could result in unexpected movement of the spring-loaded support arm which could result in personal injury.

Note: Review "Adjusting the Tracer AdaptiView Display Arm," p. 42 prior to attaching the display as some adjustments may be required prior to attaching the display to the support arm base.

6. Position the Tracer AdaptiView display, with the LCD screen facing up, on top of the display support arm base plate.

Note: Ensure the Trane logo is positioned so that it will be at the top when the Tracer AdaptiView display is attached to the display support arm.

NOTICE:

Do Not Drop Display!

Failure to keep a firm grip on the Tracer AdaptiView display as you position the display on top of the support arm base plate could result in equipment or property-only damage.

7. Align the four holes in the display with the bolt holes in the display support arm base plate.
8. Attach the Tracer AdaptiView display to the display support arm base plate (E) using the M4 (metric size 4) screws referenced in [Step 3](#).

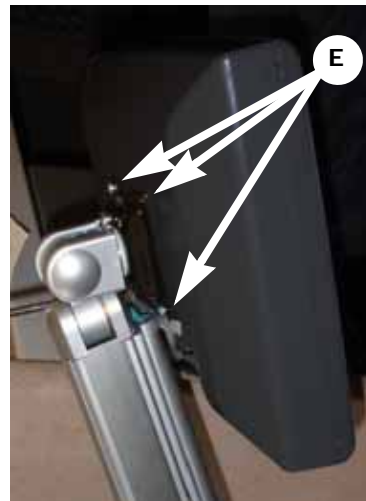

Adjusting the Tracer AdaptiView Display Arm

The Tracer AdaptiView display arm may become too loose or too tight and need adjustment. There are three joints on the display arm that allow the Tracer AdaptiView display to be positioned at a variety of heights and angles (refer to items labeled 1, 2, and 3 in [Figure 28](#)).

To adjust the tension on the display arm:

- At each joint in the display arm, there is either a hex bolt (1 and 2) or hex screw (3). Turn the hex bolt or screw in the proper direction to increase or decrease tension.

Note: Each hex bolt or screw is labeled with loosen/ tighten or +/- indicators.

Figure 28. Joint locations on the display arm

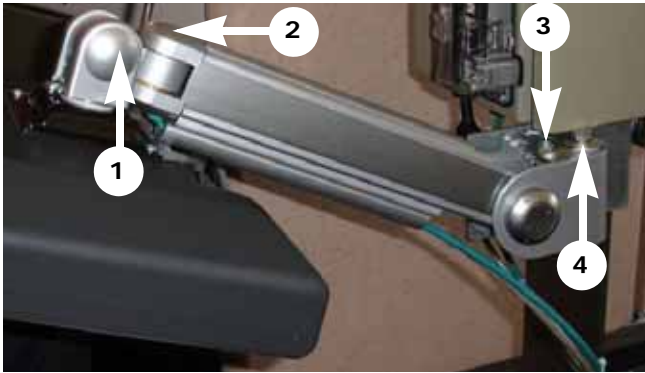

- Joint 3 has a 6 mm hex screw controlling the tension on a gas spring, which allows the Tracer AdaptiView display to tilt up and down.
- Joints 1 and 2 are covered by a plastic cap. Remove the plastic cap to access the hex bolt. Adjust using a 13 mm wrench as necessary.
- To adjust the swivel rotation tension of the Tracer AdaptiView display, adjust the hex bolt located in the support arm base plate, as described in [Step 8](#) in “[Installing the Tracer AdaptiView Display](#),” p. 41. This adjustment must be done prior to attaching the Tracer AdaptiView display to the support arm base. Use a 14 mm wrench to adjust the tension.
- To adjust the left/right swivel of the entire display arm, use a 13 mm wrench to adjust the bolt labeled 4 in [Figure 28](#).



Electrical Requirements

Installation Requirements

⚠ WARNING

Proper Field Wiring and Grounding Required!

Failure to follow code could result in death or serious injury. All field wiring **MUST** be performed by qualified personnel. Improperly installed and grounded field wiring poses **FIRE** and **ELECTROCUTION** hazards. To avoid these hazards, you **MUST** follow requirements for field wiring installation and grounding as described in **NEC** and your local/state electrical codes.

Unit-mounted starters are available as an option on most units. While this option eliminates most field-installed wiring requirements, the electrical contractor must still complete the electrical connection for the following:

- power supply wiring to the starter,
- other unit control options present, and
- any field-supplied control devices.

As you review this manual, along with the wiring instructions presented in this section, keep in mind that:

- All field-installed wiring must conform to National Electric Code (NEC) guidelines, and any applicable state and local codes. Be sure to satisfy proper equipment grounding requirements per NEC.
- Compressor motor and unit electrical data (including motor kW, voltage utilization range, rated load amps, and locked rotor amps) is listed on the chiller nameplate.
- All field-installed wiring must be checked for proper terminations, and for possible shorts or grounds.

Note: Always refer to the actual wiring diagrams that shipped with the chiller or the unit submittal for specific as-built electrical schematic and connection information.

NOTICE:

Starter Component Damage!

Failure to remove debris from inside the starter panel could result in an electrical short and could cause serious starter component damage.

Do not modify or cut enclosure to provide electrical access. Removable panels have been provided, and any modification should be done away from the enclosure. If the starter enclosure must be cut to provide electrical access, exercise care to prevent debris from falling inside the enclosure. Refer to installation information shipped with the starter or submittal drawings.

Electrical Requirements

Before wiring begins, observe the following electrical requirements:

- Follow all lockout-tagout procedures prior to performing installation and/or service on the unit.
- Always wear appropriate personal protective equipment.
- Wait the required time to allow the capacitor(s) to discharge; this could be up to 30 minutes.
- Verify that all capacitors are discharged prior to service using a properly rated volt meter.
- Use appropriate capacitor discharge tool when necessary.
- Comply with the safety practices recommended in PROD-SVB06*-EN.

⚠ WARNING

Hazardous Voltage w/Capacitors!

Failure to disconnect power and discharge capacitors before servicing could result in death or serious injury. Disconnect all electric power, including remote disconnects and discharge all motor start/run capacitors before servicing. Follow proper lockout/tagout procedures to ensure the power cannot be inadvertently energized. For variable frequency drives or other energy storing components provided by Trane or others, refer to the appropriate manufacturer's literature for allowable waiting periods for discharge of capacitors. Verify with an appropriate voltmeter that all capacitors have discharged.

For additional information regarding the safe discharge of capacitors, see PROD-SVB06-EN*

⚠ WARNING

Personal Protective Equipment (PPE) Required!

Failure to follow proper handling guidelines could result in death or serious injury. Always wear appropriate personal protective equipment in accordance with applicable regulations and/or standards to guard against potential electrical shock and flash hazards.



Electrical Requirements

⚠ WARNING

Live Electrical Components!

Failure to follow all electrical safety precautions when exposed to live electrical components could result in death or serious injury. During installation, testing, servicing and troubleshooting of this product, it may be necessary to work with live electrical components. Have a qualified licensed electrician or other individual who has been properly trained in handling live electrical components perform these tasks.

Trane-Supplied Starter Wiring

Table 12. Standard field power wiring requirements

Power Supply Wiring to Starter Panel	Starter Panel Terminals			
3-Phase Line Voltage	2X3-L1, L2, L3, and GROUND ^(a)			
3-Phase Line Voltage: Circuit Breaker	2Q1-L1, L2, L3, and GROUND			
Starter to Motor Power Wiring	Starter	Motor		
Remote Starter to Chiller Motor Junction Box	T1 through T6	T1 through T6		
Starter to Control Panel 120 Vac Control Wiring	Starter Panel Terminals	Unit Control Panel Terminations	Max Terminal Wire Size (AWG ^(b))	Minimum Circuit Ampacity
120 Vac Power Supply (from starter to control panel)	2X1-1, 2X1-2 2X1-20 (Ground)	1X1-1, 1X1-12 1X1-18 (Ground)	8	40
High Pressure Cutout to Starter	2X1-4	1X1-4	14	20
1Q1 Circuit Breaker to Starter	2X1-6	1X1-3	14	20
Oil Pump Interlock	2X1-7, 2X1-8	1A7-J2-4, 1A7-J2-2	14	20
Low Voltage Circuits less than 30 Vac	Starter Panel Terminals	Unit Control Panel Terminations		
Standard Circuits				
Inter Processor Communications (IPC) Remote Mounted ^(c)	2A1-J3-3-4, or 2X1-12 to 13 if present (do not ground shield at starter)	1A1-J5-1-2, 3-4 Shield ground at 1X1-22 (GND) only.	2 wire with ground Comm link	

Notes:

1. All wiring to be in accordance with National Electrical Code and any local codes.
2. Oil pump motor: 1 PH, 3/4 hp, 11.7 full load amps at 115 Vac.
3. Auxiliary equipment must be powered from other sources as the chiller control panel power supplies are sized for the chiller loads only.

(a) Ground lug for a unit-mounted solid state starter or wye-delta starter is sized to accept 14 AWG solid to 8 AWG strand wire. If local codes require different lug size, it must be field-supplied and -installed.

(b) Wires, lugs, and fuses/breakers are sized based on National Electric Code NEC [NFPA 70] and UL 1995.

(c) Must be separated from 120 Vac and higher wiring.

Note: CPTR, Control Power Transformer (Enhanced Electrical Protection Package option): A unit-mounted, factory-wired, separate enclosure positioned next to the control panel is available when separate source control power is required. This permits the controls to remain powered while the three-phase line voltage is disconnected. Contact your local Trane representative for more information.



Customer-Supplied Remote Starter Wiring

Table 13. Standard customer-supplied remote field wiring requirements

Power Supply Wiring to Starter Panel	Starter Panel Terminals			
Starter by others 3-phase power wiring	See starter by others schematic			
Starter to Motor Power Wiring	Starters	Motor		
Remote starter to chiller motor junction box	T1 through T6 terminals	T1 through T6 terminals		
Starter to Control Panel 120 Vac Control Wiring	Starter Panel Terminals	Unit Control Panel Terminations	Max Terminal Wire Size (AWG ^(a))	Minimum Circuit Ampacity
120 Vac Power Supply (from starter to control panel)	See starter by others schematic 5X1-1, 5X1-2, 5X1-20 (ground)	1X1-1, 1X1-12, 1X1-18 (ground)	8	40
Power from control panel 1Q1	5X1-3	1X1-3, 1A23-J6-3	14	20
Interlock relay signal	5X1-4	1A23-J10-1	14	20
Start contactor signal	5X1-5	1A23-J8-1	14	20
Oil pump interlock	5X1-7, 5X1-8	1A7-J2-4, 1A7-J2-2	14	20
Run contactor signal	5X1-10	1A23-J6-12	14	20
Transition complete	5X1-14	1A23-J12-2	14	20
Low Voltage Circuits less than 30 Vac	Starter Panel Terminals	Unit Control Panel Terminations		
Standard Circuits				
Current Transformers (see Table 14, p. 46) (Required) ^(b)	5CT4- white, black 5CT5- white, black 5CT6- white, black	1A23-J7-1,2 1A23-J7-3,4, 1A23-J7-5,6,	Note: Phasing must be maintained	
Potential Transformers (Required) ^(b)	5T17-236,237 5T18-238,239 5T19-240,241	1A23 -J5-1,2, 1A23 -J5-3,4, 1A23 -J5-5,6	Note: Phasing must be maintained	
Solid State Starter Fault ^(c)	5X1-11 5X1-12	1A24-J2-1 1A24-J2-2		

Notes:

1. All wiring to be in accordance with National Electrical Code and any local codes.
2. Starter by others specification available from your local Trane sales office.

(a) Wires, lugs, and fuses/breakers are sized based on National Electric Code NEC [NFPA 70] and UL 1995.

(b) Must be separated from 120 Vac and higher wiring.

(c) Solid State Starter Fault input is used with low- and medium-voltage, customer-supplied solid state starters only.



Customer-Supplied Remote Starter Wiring

Current Transformer and Potential Transformer Wire Sizing

For customer-supplied starter-to-chiller unit control panel starter module 1A23; these wires must be separated from 120 Vac or higher wiring.

Table 14. Maximum recommended wire length for secondary CT leads in dual CT system

Wire AWG ^(a)	Maximum Wire Length Secondary CT Leads	
	Feet	Meters
8	1362.8	415.5
10	856.9	261.2
12	538.9	164.3
14	338.9	103.3
16	213.1	65.0
17	169.1	51.5
18	134.1	40.9
20	84.3	25.7

Notes:

1. Wire length is for copper conductors only.
2. Wire length is total one-way distance that the CT can be from the starter module.

(a) Wires, lugs, and fuses/breakers are sized based on National Electric Code NEC [NFPA 70] and UL 1995.

Table 15. Maximum recommended total wire length for PTs in a single PT system

Wire AWG ^(a)	Maximum Lead Length	
	Feet	Meters
8	5339	1627
10	3357	1023
12	2112	643
14	1328	404
16	835	254
17	662	201
18	525	160
20	330	100
21	262	79
22	207	63

Notes:

1. Wire length is for copper conductors only.
2. The above length is maximum round trip wire length. The maximum distance the PT can be located from the starter module is half of the listed value.

(a) Wires, lugs, and fuses/breakers are sized based on National Electric Code NEC [NFPA 70] and UL 1995.

Table 16. Max recommended total wire length (to and from) for PT leads in a dual PT system

Wire AWG ^(a)	Max Wire Length Primary		Max Wire Length Secondary	
	Feet	Meters	Feet	Meters
8	3061	933	711	217
10	1924	586	447	136
12	1211	369	281	85
14	761	232	177	53
16	478	145	111	33
17	379	115	88	26
18	301	91	70	21
20	189	57	44	13
21	150	45	34	10
22	119	36	27	8

Notes:

1. Wire length is for copper conductors only.
2. The above length is maximum round trip wire length. The maximum distance the PT can be located from the starter module is half of the listed value.

(a) Wires, lugs, and fuses/breakers are sized based on National Electric Code NEC [NFPA 70] and UL 1995.



Power Supply Wiring

⚠ WARNING

Proper Field Wiring and Grounding Required!

Failure to follow code could result in death or serious injury. All field wiring **MUST** be performed by qualified personnel. Improperly installed and grounded field wiring poses **FIRE** and **ELECTROCUTION** hazards. To avoid these hazards, you **MUST** follow requirements for field wiring installation and grounding as described in **NEC** and your local/state electrical codes.

Three-Phase Power

Review and follow the guidelines below to properly install and connect the power supply wiring to the starter panel:

- Verify that the starter nameplate ratings are compatible with the power supply characteristics and with the electrical data on the unit nameplate.

NOTICE:

Starter Component Damage!

Failure to remove debris from inside the starter panel could result in an electrical short and could cause serious starter component damage.

NOTICE:

Use Copper Conductors Only!

Failure to use copper conductors could result in equipment damage as unit terminals are not designed to accept other types of conductors.

- Do *not* modify or cut enclosure to provide electrical access. Removable panels have been provided, and any modification should be done away from the enclosure. If the starter enclosure must be cut to provide electrical access, exercise care to prevent debris from falling inside the enclosure.
- Use copper conductors to connect the three-phase power supply to the remote- or unit-mounted starter panel.
- Flexible conduit connections are recommended to enhance serviceability and minimize vibration transmission.
- Size the power supply wiring in accordance with NEC, using the RLA value stamped on the chiller nameplate and transformer load on L1 and L2.
- Confirm that wire size is compatible with lug size stated in unit submittal.
- Make sure that the incoming power wiring is properly phased; each power supply conduit run to the starter must carry the correct number of conductors to ensure equal phase representation.

Note: Connect L1, L2, and L3 (shown below) per starter diagram provided with chiller.

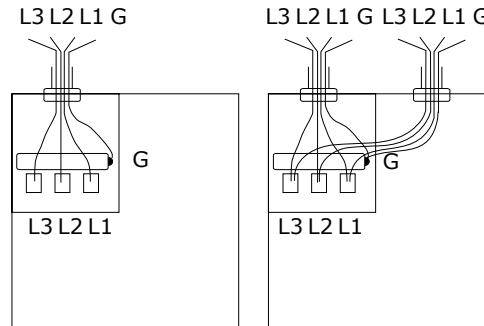

- When installing the power supply conduit, ensure that the position of the conduit does not interfere with the serviceability of any of the unit components, or with structural members and equipment. Ensure that the conduit is long enough to simplify any servicing that may be necessary in the future (e.g., starter).
- Electrical wire torque specifications—follow starter manufacturer's torque specifications.

Circuit Breakers and Fused Disconnects

Any field supplied circuit breaker or fused disconnect installed in power supplied to the chiller must be sized in compliance with NEC or local guidelines.

Power Factor Correction Capacitors (Optional)

Power factor correction capacitors (PFCCs) are designed to provide power factor correction for the compressor motor. PFCCs are available as an option for unit-mounted starters and remote mounted starters.

Notes:

- Verify PFCC voltage rating is greater than or equal to the compressor voltage rating stamped on the unit nameplate.
- Refer to the wiring diagrams that shipped with the unit for specific PFCC wiring information.

NOTICE:

Motor Damage!

Failure to wire PFCCs into the starter correctly could cause misapplication of these capacitors and result in a loss of motor overload protection and subsequently cause motor damage.

PFCCs must be wired one of two ways as shown as explained in the following (Option 1 and Option 2).

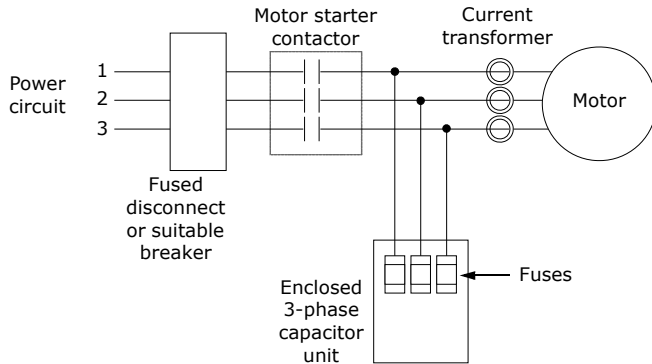

Option 1—PFCCs installed downstream of starter contactor, upstream of current transformers.

detect all current supplied to the motor is to position the PFCCs upstream of the current transformers as shown in the preceding figure. If the capacitor connection points are downstream of the current transformers, route the PFCC leads through the current transformers as shown in the following figure. This ensures that the overloads register both line and capacitor-supplied current.

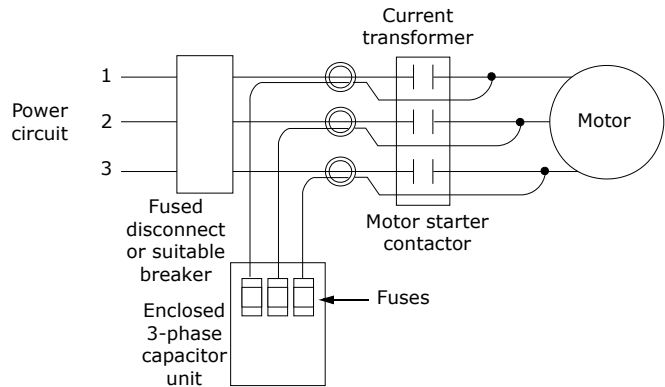

Interconnecting Wiring

Typical equipment room conduit layouts with and without unit-mounted starters are shown in [Figure 29](#) and [Figure 30](#).

Important: The interconnecting wiring between the starter panel, compressor, and control panel is factory-installed with unit-mounted starters. However, when a remote-mounted starter is used, the interconnecting wiring must be field-installed.

Note: Refer to starter submittal drawing for location of incoming wiring to the starter.

Figure 29. Typical equipment room layout for units with unit-mounted starters

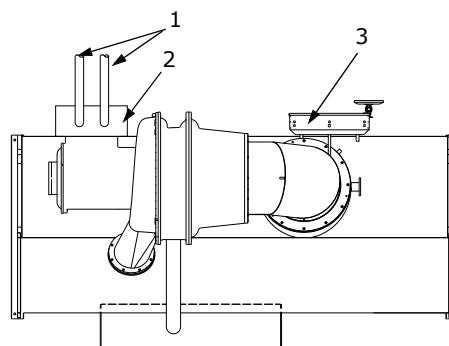

1. Line side power conduits
2. Unit-mounted starter
3. Unit control panel

⚠ WARNING

Hazardous Voltage w/Capacitors!

Failure to disconnect power and discharge capacitors before servicing could result in death or serious injury. Disconnect all electric power, including remote disconnects and discharge all motor start/run capacitors before servicing. Follow proper lockout/tagout procedures to ensure the power cannot be inadvertently energized. For variable frequency drives or other energy storing components provided by Trane or others, refer to the appropriate manufacturer's literature for allowable waiting periods for discharge of capacitors. Verify with an appropriate voltmeter that all capacitors have discharged.

For additional information regarding the safe discharge of capacitors, see PROD-SVB06-EN*

Simultaneously disconnect capacitors and load from line power. If the capacitors are not switched offline when the load is disconnected, they continue to add capacitance to the electrical distribution system. A leading power factor—too much capacitance—may eventually develop. This overprotection causes poor voltage regulation (i.e., voltage is high when the circuit is unloaded, then drops as loads are added).

Option 2—PFCC wires routed through current transformers.

Size motor overload protection to account for capacitor-supplied current. Overloads are typically set to measure the total current drawn by the motor. When PFCCs are used, they become the source of part of that current. If the current they provide is not registered by the overload protectors, potentially damaging amperage can reach the motor. The simplest way to ensure that the overloads

Figure 30. Typical equipment room layout for units with remote-mounted starters

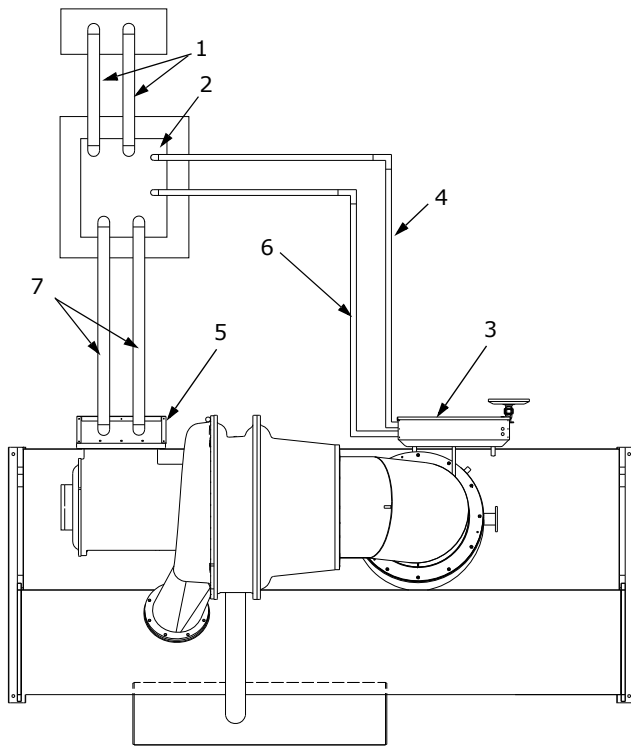

1. Line side power conduits
 2. Remote-mounted starter
 3. Unit control panel
 4. IPC Circuit conduit less than 30V (and CT/PT wiring for starters by others)
Note: Must enter the low voltage Class 2 portion of the unit control panel (1000 feet [304.8 m] max).
 5. Motor terminal box
 6. 115 V Control conduit
Note: Must enter the higher than 30 Vdc Class 1 portion of the unit control panel.
 7. Lead power wiring
- Notes:**
- Refer to the unit field connection diagram for approximate unit control panel knock out locations.
 - To prevent damage to the unit control panel components, do not route control conduit into the top of the box.

Starter to Motor Wiring (Remote-Mounted Starters Only)

Ground Wire Terminal Lugs

Ground wire lugs are provided in the motor terminal box and in the starter panel.

Terminal Clamps

NOTICE:

Use Copper Conductors Only!

Failure to use copper conductors could result in equipment damage as unit terminals are not designed to accept other types of conductors.

Terminal clamps are supplied with the motor terminals to accommodate either bus bars or standard motor terminal wire lugs. Terminal clamps provide additional surface area to minimize the possibility of improper electrical connections.

Wire Terminal Lugs

Wire terminal lugs must be field supplied.

- Use field-provided, crimp-type wire terminal lugs properly sized for the application.
Note: Wire size ranges for the starter line and load-side lugs are listed on the starter submittal drawings supplied by the starter manufacturer or Trane. Carefully review the submitted wire lug sizes for compatibility with the conductor sizes specified by the electrical engineer or contractor.
- On 4160 V and below, a terminal clamp with a 3/8-in. (9.525-mm) bolt is provided on each motor terminal stud; use the factory-supplied Belleville washers on the wire lug connections. [Figure 31](#) illustrates the junction between a motor terminal stud and terminal lug.

Figure 31. Terminal stud, clamp, and lug assembly (4160 V and below)

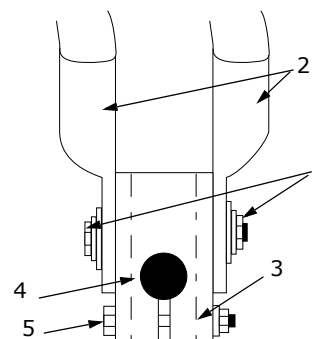

1. Belleville washer
 2. Terminal lugs
 3. Terminal clamp
 4. Motor terminal stud
 5. 3/8-in. bolt
- Torque for this assembly is 24 ft·lb (32.5 N·m).
 - Install but do *not* connect the power leads between the starter and compressor motor. (These connections will



Power Supply Wiring

be completed under supervision of a qualified Trane service engineer after the pre-start inspection.)

NOTICE:

Component Damage!

Failure to ensure the power supply wiring and output to motor wiring are connected to the proper terminals. could cause catastrophic failure of the starter and/or motor.

Bus Bars

Bus bars and extra nuts are available as a Trane option. Install the bus bars between the motor terminals when using a starter that is:

- a low-voltage AFD
- across-the-line
- primary reactor/resistor
- auto transformer
- customer-supplied

Connect T1 to T6, T2 to T4, and T3 to T5.

Note: Bus bars are not needed in medium-voltage or high-voltage applications since only 3 terminals are used in the motor and starter.

When attaching starter leads to 6.6–7 kV motor terminals, the 1/2-in.-13 brass jam nuts should be tightened to a maximum torque of 18 to 22 ft·lb (24.4 to 29.8 N·m). Always use a second wrench to backup the assembly and prevent applying excessive torque to the terminal shaft.

Starter to Control Panel Wiring

The unit submittal includes the field wiring connection diagram and the starter-to-control-panel connection diagram (showing the electrical connections required between the remote-mounted starter and the control panel).

Note: Install separate conduit into the low voltage (30 volts) section of the control panel.

When sizing and installing the electrical conductors for these circuits, follow the guidelines listed. Use 14 AWG for 120V control circuits unless otherwise specified.

NOTICE:

Component Damage!

Remove all debris from inside the starter panel. Failure to do so could result in an electrical short and could cause serious starter component damage.

Important: Maintain at least 6 in. (16) between low-voltage (<30V) and high voltage circuits. Failure to do so could result in electrical noise that may distort the signals carried by the low voltage wiring, including the IPC wiring.

To wire the starter to the control panel, follow the guidelines below:

- If the starter enclosure must be cut to provide electrical access, exercise care to prevent debris from falling inside the enclosure. Do *not* cut AFD enclosure.
- Use only shielded, twisted-pair wiring for the Interprocessor Communication (IPC) circuit between the starter and the control panel on remote mounted starters.

Note: Recommended wire is Beldon Type 8760, 18 AWG for runs up to 1000 ft (304.8 m). The polarity of the IPC wiring is critical for proper operation.

- Separate low-voltage (less than 30V; refer to [Table 12, p. 44](#) and [Table 13, p. 45](#)) wiring from the 115V wiring by running each in its own conduit.
- When routing the IPC circuit out of the starter enclosure, ensure that it is at least 6 in. (16 cm) from all wires carrying a higher voltage.

⚠ WARNING

Proper Field Wiring and Grounding Required!

Failure to follow code could result in death or serious injury. All field wiring **MUST** be performed by qualified personnel. Improperly installed and grounded field wiring poses **FIRE** and **ELECTROCUTION** hazards. To avoid these hazards, you **MUST** follow requirements for field wiring installation and grounding as described in NEC and your local/state electrical codes.

- *The IPC wiring shield should be grounded on one end only at control panel end. The other end should be un-terminated and taped back on the cable sheath to prevent any contact between shield and ground.*
- *Oil Pump Interlock: All starters must provide an interlock (normally open) contact with the chiller oil pump connected to the control panel at terminals 1A7-2-4 and 1A7-J2-2 (14 AWG) The purpose of this interlock is to maintain the oil pump signal in the event that a starter failure, such as welded contacts, keeps the chiller motor running after the controller interrupts the run signal.*

10kV–13.8kV Medium Voltage Installation

⚠ WARNING

Hazardous Voltage!

Failure to disconnect power before servicing could result in death or serious injury. Disconnect all electric power, including remote disconnects before servicing. Follow proper lockout/tagout procedures to ensure the power can not be inadvertently energized.

All electrical circuits shall be treated as energized until all lockout-tagout procedures are in place and the circuit has been tested to verify that it is de-energized. The medium voltage motor terminal box cover must not be removed if power is present, or if there is a possibility that power may be present. Working on energized medium voltage circuits is not an approved practice for normal HVAC maintenance or service.

10kV–13.8kV Medium Voltage Motor

The motor is suitable for remote mounted across-the-line (including circuit breaker starting), primary reactor, autotransformer, or solid-state starting. Refer to the unit nameplate for motor data including RLA, LRA, etc.

In all cases of non-Trane supplied starters, the Trane Engineering Specification for UC800 Starter By Others (available through your local Trane office) must be followed in order to ensure proper function and protection of the chiller. A disconnecting means and short-circuit protection must be installed ahead of the starter, unless they are included as part of the starter.

Note: Trane assumes no responsibility for the design, documentation, construction, compatibility, installation, start-up, or long term support of starters provided by others.

Motor Terminal Box

A large steel motor terminal box is provided to allow for the field connection of the motor power supply wire to the motor.

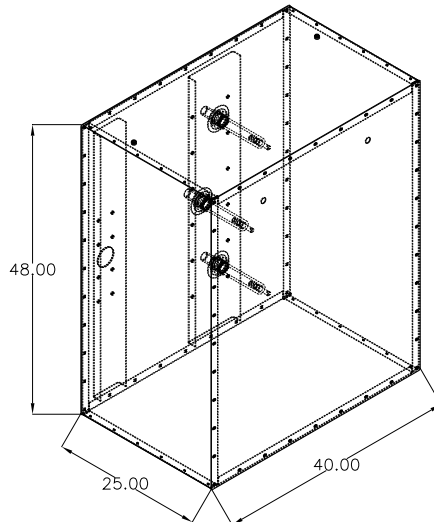

Note: Dimensions in inches

- Motor terminal box cover-only weight is 55 lb (25 kg).
- Two 7/8-in. (22.225 mm) lifting holes are provided in the cover.
- Motor terminal box weight without the cover is 215 lb (97.5 kg).
- Two 3/8-in.-16 weld nuts are provided on the top of the terminal box to allow the use of properly rated lifting d-rings if removal is needed for clearance purposes.

Note: If the box is removed for installation purposes, the motor terminals MUST be protected against impact or stress damage. Field fabrication of a cover or guard is required.

- The motor terminal box is large enough to accommodate the use of stress cones.
- If conduit is applied, a flexible connection of the conduit to the box should be made to allow for unit serviceability and for vibration isolation. The cable should be supported or protected against abrasion and wear on any edges or surfaces. Cable or conduit openings can be cut at any location in the box sides, top, or bottom for cable entry. Always ensure that debris does not remain in the box after cutting cable entry holes.

Motor Supply Wiring

⚠ WARNING

Proper Field Wiring and Grounding Required!

Failure to follow code could result in death or serious injury. All field wiring **MUST** be performed by qualified personnel. Improperly installed and grounded field wiring poses **FIRE** and **ELECTROCUTION** hazards. To avoid these hazards, you **MUST** follow requirements for field wiring installation and grounding as described in **NEC** and your local/state electrical codes.

Motor circuit wire sizing by the installer must be made in accordance with the National Electric Code or any other applicable codes. All wiring to the CenTraVac motor must be shielded copper, with insulation rated to a minimum of 15kV.

Three terminals are provided on the chiller for the connection of power to the motor from the starter. Power leads to motors must be in multiples of three, with equal phase representation in all conduits or wire trays. To limit the effects of corona or ionization with cables carrying more than 2000V, Trane requires that the power cable have a metallic shield, unless the cable is specifically listed or approved for non-shielded use. If the cable is shielded, the shielding must be grounded at one end (grounding is typically done at the starter or supply end).

Care must be taken while routing the incoming cables to ensure that cable loads or tensions are not applied to the terminal or premature terminal failure could result.

Motor Terminals

Field-provided, ring-type lugs, with no sharp edges or corners, must be used by a qualified installer to connect the power wiring to the motor terminals. Follow all instructions provided with the field-provided lugs to ensure proper connections.

Important: The use of stress cones is highly recommended to reduce and control longitudinal and radial electrical stresses at the cable ends.

Prior to assembly the terminal stud, nuts, and lug should be inspected and cleaned to ensure they are not damaged or contaminated. The terminal has a copper shaft that is threaded 9/16-in.–18 UNF2A. Brass nuts are provided on the motor terminals to retain the lugs, and the final connection should be tightened to 22–25 ft·lb (29.8–33.9 N·m) using a 7/8-in. (22.225-mm) socket on a torque wrench.

NOTICE:

Motor Terminal Damage!

Applying torque to the motor terminal when tightening lugs could cause equipment or property-only damage. Always use a second wrench to back-up the assembly and prevent the application of torque to the terminal shaft.

Before beginning wiring and torquing, ensure proper motor terminal care and do not apply any excess stress.

Ground Wire Terminal Lug

A ground wire lug is provided in the motor terminal box to allow the field connection of an earth ground. The lug will accept a field supplied ground wire of #8 to #2 AWG. After completing the field connection of wiring, inspect and clean the motor terminals and motor housing, and remove any debris before reinstalling the motor terminal box cover. The cover must be re-installed onto the motor terminal box and all bolts installed. Do not operate the chiller with the motor terminal box cover removed or with any loose or missing cover bolts.



System Control Circuit Wiring (Field Wiring)

Table 17. Unit control panel wiring 120 Vac

Standard Control Circuits: Unit Control Panel Control Wiring (120 Vac)	Unit Control Terminations	Input or Output Type	Contacts
Chilled Water Flow Proving Input ^(a)	1X1-5 to 1A6-J3-2	Binary Input	Normally Open, closure with flow
Condenser Water Flow Proving Input ^(b)	1X1-6 to 1A6-J2-2	Binary Input	Normally Open, closure with flow
Chilled Water Pump Relay Output	1A5-J2-4 to 6	Binary Output	Normally Open
Condenser Water Pump Relay Output	1A5-J2-1 to 3	Binary Output	Normally Open
Optional Control Circuits (120 Vac)	Note: Defaults are factory programmed, alternates can be selected at start-up using the service tool.		
Alarm Relay MAR (Non-Latching) Output	1A8-J2-1 to 3	Binary Output	Normally Open
Limit Warning Relay Output	1A8-J2-4 to 6	Binary Output	Normally Open
Alarm Relay MMR (Latching) Output	1A8-J2-7 to 9	Binary Output	Normally Open
Compressor Running Relay Output	1A8-J2-10 to 12	Binary Output	Normally Open
Maximum Capacity Relay Output	1A9-J2-1 to 3	Binary Output	Normally Open
Head Relief Request Relay Output	1A9-J2-4 to 6	Binary Output	Normally Open
Purge Alarm Relay Output	1A9-J2-7 to 9	Binary Output	Normally Open
Ice Making Relay Output	1A5-J2-10 to 12	Binary Output	Normally Open
Free Cooling Relay Output	1A11-J2-4 to 6	Binary Output	Normally Open
Standard Low Voltage Circuits (less than 30 Vac)^(c)	Unit Control Panel Terminations	Input or Output Type	Contacts
External Auto Stop Input	1A13-J2-1 to 2	Binary Input	Closure required for normal operation
Emergency Stop Input	1A13-J2-3 to 4	Binary Input	Closure required for normal operation
Optional Low Voltage Circuits			
External Base Loading Enable Input	1A18-J2-1 to 2	Binary Input	Normally Open
External Hot Water Control Enable Input	1A18-J2-3 to 4	Binary Input	Normally Open
External Ice Machine Control Enable Input	1A19-J2-1 to 2	Binary Input	Normally Open
External Free Cooling Input Enable Input	1A20-J2-1 to 2	Binary Input	Normally Open
% RLA Compressor Output	1A15-J2-1 to 3	Analog Output	2–10 Vdc
External Condenser Pressure Output	1A15-J2-4 to 6	Analog Output	2–10 Vdc
Evaporator/Condenser Differential Pressure Output	1A15-J2-4 to 6	Analog Output	2–10 Vdc
Condenser Head Pressure Control	1A15-J2-4 to 6	Analog Output	2–10 Vdc
External Current Limit Setpoint Input	1A16-J2-2 to 3	Analog Input	2–10 Vdc, or 4–20 mA
External Chilled Water Setpoint Input	1A16-J2-5 to 6	Analog Input	2–10 Vdc, or 4–20 mA
External Base Loading Setpoint Input	1A17-J2-2 to 3	Analog Input	2–10 Vdc, or 4–20 mA
Generic Refrigerant Monitor input	1A17-J2-5 to 6	Analog Input	2–10 Vdc, or 4–20 mA
Outdoor Air Temperature sensor	IPC bus Connection and sensor	Communication and sensor	
Tracer Comm Interface or LonTalk	-J2-1(+) to 2(-) -J2-3(+) to 4(-)	Communication to Tracer or LonTalk	(as ordered, see sales order)
BACnet or MODBUS	1A22, 5(+) to 6(-)	Communication to BACnet or MODBUS	(as ordered, see sales order)

Note: All wiring to be in accordance with National Electrical Codes and any local codes

- (a) If the Chilled Water Flow Proving Input is a factory-installed ifm efector flow-sensing device, the secondary field device (recommended with 38°F [3.3°C] and lower leaving chilled water temperatures) for proof of flow connects from 1X1-5 to 1K26-4 (binary input; normally open, closure with flow). Remove factory jumper when used.
- (b) If the Condenser Water Flow Proving Input is a factory-installed ifm efector flow-sensing device, the secondary (optional) field device for proof of flow connects from 1X1-6 to 1K27-4 (binary input; normally open, closure with flow). Remove factory jumper when used.
- (c) Standard low-voltage circuits (less than 30 Vac) must be separated from 120 Vac or higher wiring.



System Control Circuit Wiring (Field Wiring)

Water Pump Interlock Circuits and Flow Switch Input

⚠ WARNING

Hazardous Voltage!

Failure to disconnect power before servicing could result in death or serious injury. Disconnect all electric power, including remote disconnects before servicing. Follow proper lockout/tagout procedures to ensure the power can not be inadvertently energized.

Note: The circuits for the chilled water proof of flow and the condenser water proof of flow do NOT require external power. Refer to the wiring diagrams that shipped with the chiller.

Chilled water pump

1. Wire the evaporator water pump contactor (5K1) to a separate 120 volt single phase power supply with 14 AWG, 600 volt copper wire.
2. Connect circuit to 1A5-J2-6.
3. Use 1A5-J2-4 120 Vac output to allow the control panel to control the evaporator water pump, or wire the 5K1 contactor to operate remotely and independently of the control panel.

Chilled water proof of flow

When this circuit is installed properly and the evaporator pump is running and providing the required minimum flow, this circuit will prove the evaporator water flow for the chiller controls. Proof of evaporator water flow is required before the start sequence will be allowed to proceed and a loss of evaporator water flow during chiller operation will result in a chiller shut-down.

Refer to as-built schematics on the inside of the control panel for field wiring. This is a dry binary input; normally-open, closure for flow. Apply no external power.

1. With factory-installed ifm efector flow-sensing devices, a field-provided secondary flow-sensing device is recommended with applications having 38°F (3.3°C) and below leaving evaporator water temperatures. When a secondary flow-sensing device is used, remove the factory jumper and install its contacts between 1X1-5 to 1K26-4; this places the secondary flow sensing device in series with the ifm efector.
2. For field-provided primary proof of flow devices, connect the primary proof of flow device between terminals 1X1-5 to 1A6-J3-2. A secondary field device is recommended with applications having 38°F (3.3°C) and below leaving evaporator water temperatures, and must be field-wired in series with the primary proof of flow device.

Condenser water pump

1. Wire the condenser water pump contactor (5K2) to a separate 120-volt, single phase power supply with 14 AWG, 600-volt copper wire.
2. Connect circuit to control panel terminals 1A5-J2-3.
3. Use 1A5-J2-1 120 Vac output to allow the control panel to control the condenser pump.

Condenser water proof of flow

When this circuit is installed properly and the condenser pump is running and providing the required minimum condenser water flow, this circuit will prove the condenser water flow for the chiller controls. Proof of condenser water flow is also required for the start sequence will be allowed to proceed and a loss of condenser water flow during chiller operation will result in a chiller shut-down.

Refer to as-built schematics on the inside of the control panel for field wiring. This is a dry binary input; normally-open, closure for flow. Apply no external power.

1. With factory-installed ifm efector flow-sensing devices, a secondary field-provided flow-sensing device is optional. When a secondary flow-sensing device is used, remove the factory jumper, and install its contacts between 1X1-5 to 1K27-4; this places the secondary flow sensing device in series with the ifm efector.
2. For field-provided primary proof of flow devices, connect the primary proof of flow device between terminals 1X1-6 to 1A6-J2-2. The secondary field provided flow sensing device is optional; however, when it is present, it must be field-wired in series with the primary proof of flow device.

Temperature Sensor Circuits

All temperature sensors are factory installed except the optional outdoor air temperature sensor. This sensor is required for the outdoor air temperature type of chilled water reset. Use the following guidelines to locate and mount the outdoor air temperature sensor. Mount the sensor probe where needed, however, mount the sensor module in the control panel.

CWR—Outdoor Option

The outdoor temperature sensor is similar to the unit-mounted temperature sensors in that it consists of the sensor probe and the module. A four-wire IPC bus is connected to the module for 24 Vdc power and the communications link. Trane recommends mounting the sensor module within the control panel and the sensor two wire leads be extended and routed to the outdoor temperature sensor probe sensing location. This ensures the four-wire IPC bus protection and provides access to the module for configuration at start-up.

The sensor probe lead wire between the sensor probe and the module can be separated by cutting the two-wire

probe lead leaving equal lengths of wire on each device: the sensor probe and the sensor module.

Note: This sensor and module are matched and must remain together or inaccuracy may occur.

These wires can then be spliced with two 14–18 AWG600V wires of sufficient length to reach the desired outdoor location with a maximum length 1000 feet (304.8 meters). The module four-wire bus must be connected to the control panel four-wire bus using the Trane-approved connectors provided.

The sensor will be configured (given its identity and become functional) at start-up when the Trane service technician performs the start-up configuration. It will NOT be operational until that time.

Note: If shielded cable is used to extend the sensor leads, be sure to cover the shield wire with tape at the junction box and ground it at the control panel. If the added length is run in conduit, do not run them in the same conduit with other circuits carrying 30 or more volts.

Important: Maintain at least 6 in. (16 cm) between low-voltage (<30V) and high voltage circuits. Failure to do so could result in electrical noise that may distort the signals carried by the low-voltage wiring, including the IPC.

Optional Control and Output Circuits

Install various optional wiring as required by the owner's specifications (see [Table 17, p. 53](#)).

Optional Tracer Communication Interface

This control option allows the control panel to exchange information—such as chiller status and operating set points—with a Tracer system.

Note: The circuit must be run in separate conduit to prevent electrical noise interference.

Additional information about the Tracer Communication interface option is published in the installation and operation guide that ships with the Tracer.

Unit Start-up/Commissioning

Important: Start-up must be performed by Trane or an agent of Trane specifically authorized to perform start-up and warranty of Trane® products. Contractor shall provide Trane (or an agent of Trane specifically authorized to perform start-up) with notice of the scheduled start-up at least two weeks prior to the scheduled start-up.

Starter Module Configuration

The starter module configuration settings will be checked (and configured for Remote Starters) during start-up commissioning.

Note: To configure starter modules, and perform other starter checks, it is recommended that the line voltage three-phase power be turned off and secured (locked out), and then that a separate source control power (115 Vac) be utilized to power up the control circuits.

Use the as-built starter schematic to ensure correct fuse and terminals. Verify that the correct fuse is removed and that the control circuit connections are correct; then apply the 115 Vac separate source power to service the controls.

Schematic Wiring Drawings

Please refer to the submittals and drawings that shipped with the unit. Additional wiring drawings for CenTraVac chillers are available from your local Trane office.

Operating Principles

General Requirements

Operation and maintenance information for CVHE, CVHF, and CVHG chillers are covered in this section. This includes both 50 and 60 Hz centrifugal chillers equipped with the Tracer AdaptiView UC800 control system. This information pertains to all chiller types unless differences exist, in which case the sections are listed by chiller type as applicable and described separately. By carefully reviewing this information and following the instructions given, the owner or operator can successfully operate and maintain a CenTraVac unit. If mechanical problems do occur, however, contact a Trane service technician to ensure proper diagnosis and repair of the unit.

Cooling Cycle

When in the cooling mode, liquid refrigerant is distributed along the length of the evaporator and sprayed through small holes in a distributor (i.e., running the entire length of the shell) to uniformly coat each evaporator tube. Here, the liquid refrigerant absorbs enough heat from the system water circulating through the evaporator tubes to vaporize. The gaseous refrigerant is then drawn through the eliminators (which remove droplets of liquid refrigerant from the gas) and the first stage variable inlet guide vanes, and into the first-stage impeller.

CVHE and CVHG 3-Stage Compressor

Compressed gas from the first-stage impeller flows through the fixed, second-stage inlet vanes and into the second-stage impeller. Here, the refrigerant gas is again compressed, and then discharged through the third-stage variable guide vanes and into the third-stage impeller. Once the gas is compressed a third time, it is discharged into the condenser. Baffles within the condenser shell distribute the compressed refrigerant gas evenly across the condenser tube bundle. Cooling tower water circulated through the condenser tubes absorbs heat from the refrigerant, causing it to condense. The liquid refrigerant then passes through an orifice plate and into the economizer.

The economizer reduces the energy requirements of the refrigerant cycle by eliminating the need to pass all gaseous refrigerant through three stages of compression (see Figure 33, p. 56). Notice that some of the liquid refrigerant flashes to a gas because of the pressure drop created by the orifice plates, thus further cooling the liquid refrigerant. This flash gas is then drawn directly from the first and second stages of the economizer into the third- and second-stage impellers of the compressor, respectively. All remaining liquid refrigerant flows through another orifice plate to the evaporator.

Figure 32. Pressure enthalpy curve, 3-stage

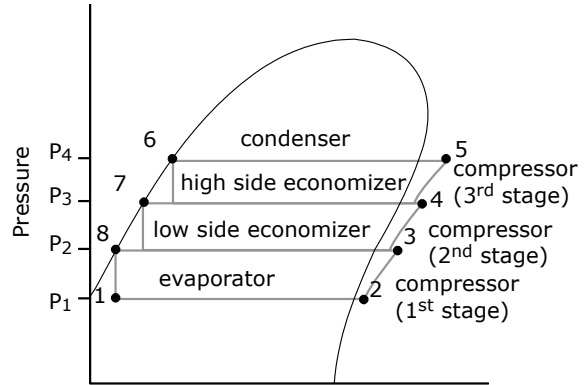
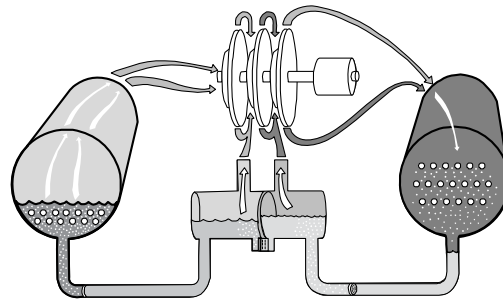

Figure 33. Refrigerant flow, 3-stage



CVHF 2-Stage Compressor

Compressed gas from the first-stage impeller is discharged through the second-stage variable guide vanes and into the second-stage impeller. Here, the refrigerant gas is again compressed, and then discharged into the condenser. Baffles within the condenser shell distribute the compressed refrigerant gas evenly across the condenser tube bundle. Cooling tower water, circulated through the condenser tubes, absorbs heat from the refrigerant, causing it to condense. The liquid refrigerant then flows out of the bottom of the condenser, passing through an orifice plate and into the economizer.

The economizer reduces the energy requirements of the refrigerant cycle by eliminating the need to pass all gaseous refrigerant through both stages of compression (see Figure 35). Notice that some of the liquid refrigerant flashes to a gas because of the pressure drop created by the orifice plate, thus further cooling the liquid refrigerant. This flash gas is then drawn directly from the economizer into the second-stage impellers of the compressor. All remaining liquid refrigerant flows through another orifice plate and into the evaporator.

Figure 34. Pressure enthalpy curve

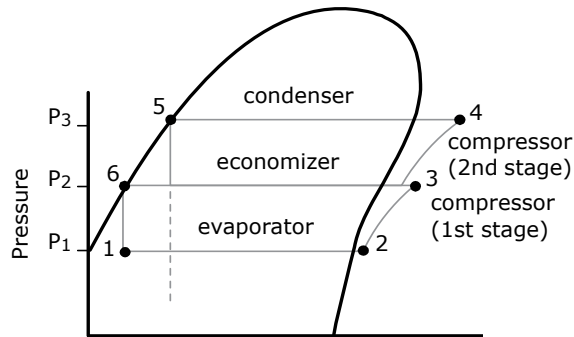
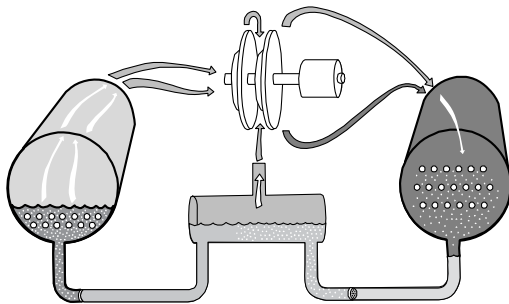

Figure 35. Refrigerant flow, 2-stage



Oil and Refrigerant Pump

Compressor Lubrication System

A schematic diagram of the compressor lubrication system is illustrated in [Figure 36, p. 58](#). Oil is pumped from the oil tank (by a pump and motor located within the tank) through an oil pressure regulating valve designed to maintain a net oil pressure of 18 to 22 psid (124.1 to 151.7 kPaD). It is then filtered and sent to the oil cooler located in the economizer and on to the compressor motor bearings. From the bearings, the oil drains back to the manifold and separator under the motor and then on to the oil tank.

Figure 36. Oil refrigerant pump

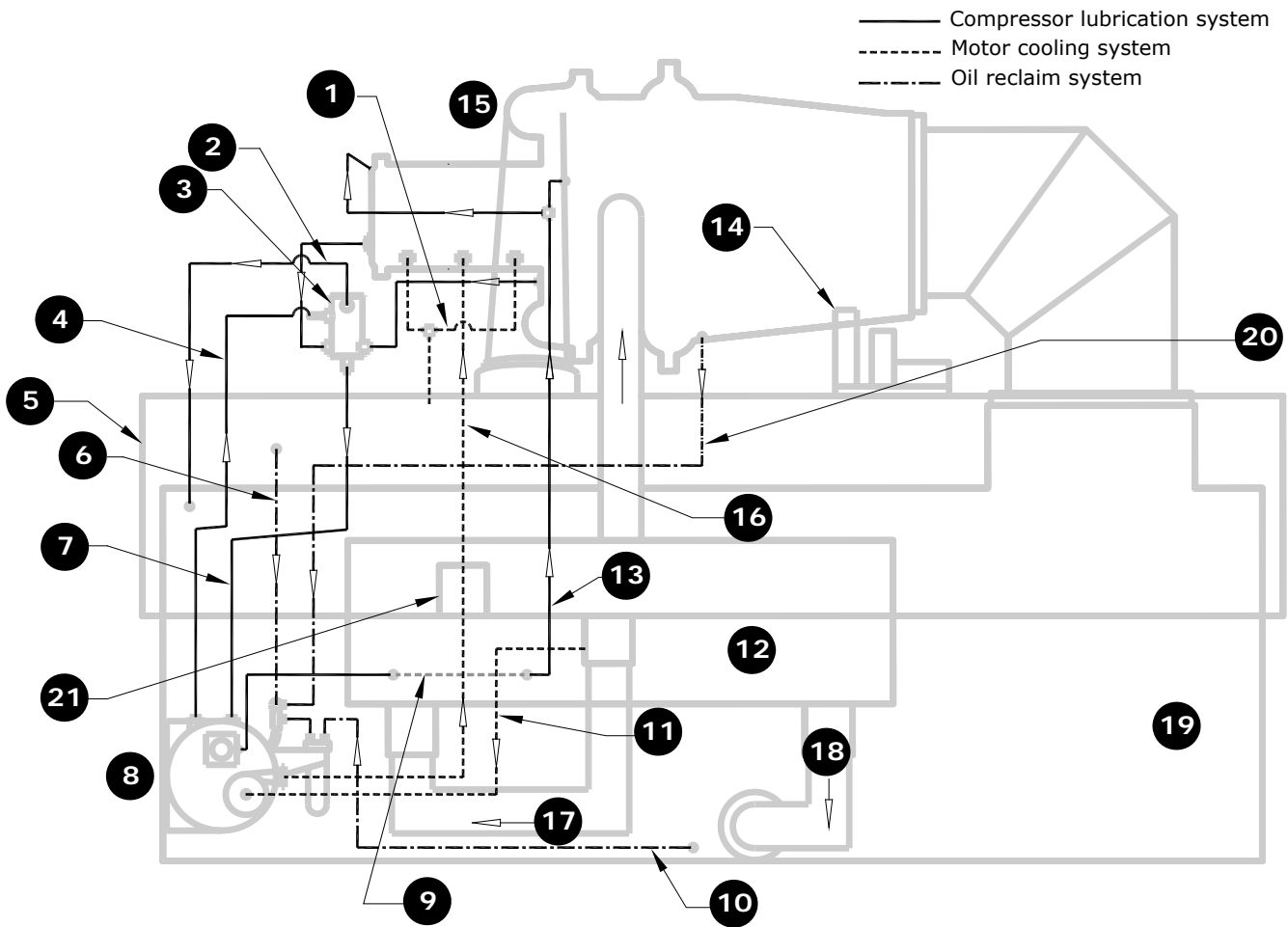

- | | |
|---|---|
| 1. Motor coolant return to condenser, 2.125 in. (53.975 mm) OD | 12. Economizer |
| 2. Oil tank vent to evaporator | 13. Oil supply to bearings, 0.625 in. (15.875 mm) OD |
| 3. Oil separator and tank vent manifold | 14. Purge |
| 4. Tank vent line | 15. Compressor |
| 5. Condenser | 16. Liquid refrigerant motor coolant supply, 1.125 in. (28.575 mm) OD |
| 6. High pressure condenser gas to drive oil reclaim eductors, 0.375 in. (9.525 mm) OD | 17. Liquid refrigerant to economizer |
| 7. Oil return to tank | 18. Liquid refrigerant to evaporator |
| 8. Oil tank | 19. Evaporator |
| 9. Oil cooler within economizer 0.625 in. (15.875 mm) OD coiled tubing | 20. Oil reclaim from suction cover (1 st eductor), 0.25 in. (6.35 mm) OD |
| 10. Oil reclaim from evaporator (2 nd eductor), 0.25 in. (6.35 mm) OD | 21. Motor coolant filter |
| 11. Liquid refrigerant to pump, 1.625 in. (41.275 mm) OD | |

⚠ WARNING**Hot Surface!**

Failure to use caution while working on the oil system could result in severe burns. Oil system temperature could exceed 150°F (65.6°C).

To ensure proper lubrication and prevent refrigerant from condensing in the oil tank, a 750-watt heater is in a well in the oil tank. The heater is used to warm the oil while the unit is off. With the default settings, the oil heater is de-energized when the unit starts. The heater energizes as needed to maintain 140°F to 145°F (60.0°C to 62.8°C) when the chiller is not running.

When the chiller is operating, the temperature of the oil tank is typically 100°F to 160°F (37.8°C to 71.1°C). The oil return lines from the thrust and journal bearings, transport oil and some seal leakage refrigerant. The oil return lines are routed into a manifold and separator under the motor. Gas flow exits the top of the manifold and is vented to the evaporator. Oil exits the bottom of the manifold and returns to the tank. Separation of the seal leakage gas in the separator keeps this gas out of the tank.

A dual eductor system is used to reclaim oil from the suction cover and the evaporator, and deposit it back into the oil tank. These eductors use high-pressure condenser gas to draw the oil from the suction cover and evaporator to the eductors and then discharged into the oil tank. The evaporator eductor line has a shut-off valve mounted by the evaporator. The shut-off valve will be set during commissioning but may be adjusted later by a qualified technician, as necessary for oil return. A normal operating setting for the valve may range from full closed to two turns open.

Note: Depending on operating conditions, the oil sump's normal operating oil level may vary from just below the bottom sight glass to near the top of the upper sight glass.

Liquid refrigerant is used to cool the oil supply to both the thrust bearing and journal bearings. On refrigerant pump units the oil cooler is located inside the economizer and uses refrigerant passing from the condenser to evaporator to cool the oil. Oil leaves the oil cooler and flows to both the thrust and journal bearings.

Motor Cooling System

Compressor motors are cooled with liquid refrigerant (see [Figure 36, p. 58](#)). The refrigerant pump is located on the front of the oil tank (motor inside the oil tank). The refrigerant pump inlet is connected to the well at the bottom of the condenser. The connection is on the side where a weir ensures a preferential supply of liquid refrigerant. Refrigerant is delivered to the motor via the pump. An in-line filter is installed (replace the in-line filter only with major service). Motor refrigerant drain lines are routed to the condenser.

Tracer AdaptiView Display

Information is tailored to operators, service technicians, and owners.

When operating a chiller, there is specific information you need on a day-to-day basis—setpoints, limits, diagnostic information, and reports.

Day-to-day operational information is presented at the display. Logically organized groups of information—chiller modes of operation, active diagnostics, settings and reports put information conveniently at your fingertips. For more information, refer to *Tracer AdaptiView™ Display for Water-Cooled CenTraVac™ Chillers Operations Guide* (CTV-SVU01*-EN, or the most recent version).

Start-up and Shut-down

This section will provide basic information on chiller operation for common events. With microelectronic controls, ladder diagrams cannot show today's complex logic, as the control functions are much more involved than older pneumatic or solid state controls.

Sequence of Operation

Adaptive control algorithms can also complicate the exact sequence of operation. This section illustrates common control sequences.

Software Operation Overview Diagram

Figure 37 is a diagram of the five possible software states. This diagram can be thought of as a state chart, with the Figure 37. Software operation overview

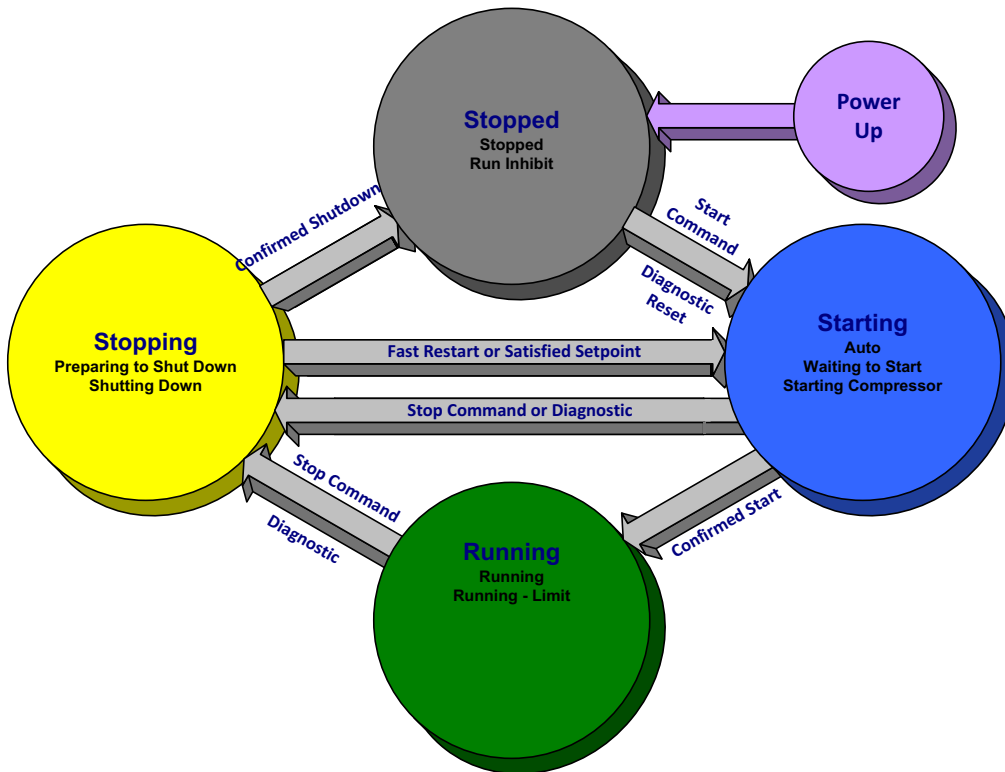

arrows, and arrow text, depicting the transitions between states.

Descriptions

- The text in the circles are the internal software designations for each state.
- The first line of text in the circles are the visible top level operating modes that can be displayed on Tracer AdaptionView.
- The shading of each software state circle corresponds to the shading on the time lines that show the state that the chiller is in.

There are five generic states that the software can be in:

- Power Up
- Stopped
- Starting
- Running
- Stopping

Descriptions

- The time line indicates the upper level operating mode, as it would be viewed on Tracer AdaptiView.
- The shading color of the cylinder indicates the software state.
- Text in parentheses indicates sub-mode text as viewed on Tracer AdaptiView.
- Text above the time line cylinder is used to illustrate inputs to the Main Processor. This may include User input to the Tracer AdaptiView Touch screen, Control inputs from sensors, or Control Inputs from a Generic BAS.
- Boxes indicate Control actions such as Turning on Relays, or moving the Inlet Guide Vanes.
- Smaller cylinders indicate diagnostic checks, text indicates time based functions, solid double arrows indicate fixed timers, and dashed double arrows indicate variable timers.

Start-up Sequence of Operation—Wye-Delta

Logic Circuits within the various modules will determine the starting, running, and stopping operation of the chiller. When operation of the chiller is required the chiller mode is set at “Auto.” Using customer supplied power, the chilled water pump relay is energized and chilled water flow must be verified within 4 minutes and 15 seconds. The main processors logic decides to start the chiller based on the differential to start setpoint. With the differential to start criteria met, the module then energizes condenser water pump relay with customer supplied power (see [Figure 38, p. 61](#)).

Based on the Restart Inhibit function and the Differential to Start setpoint, the oil and refrigerant pump is energized. The oil pressure must be at least 9 psid (62.1 kPaD) for 60 continuous seconds and condenser water flow verified within 4 minutes and 15 seconds for the compressor start sequence to be initiated.

The compressor motor starts in the “Wye” configuration and then, after the compressor motor has accelerated and the maximum phase current has dropped below 85 percent of the chiller nameplate RLA for 1.5 seconds, the starter transitions to the “Delta” configuration.

Figure 38. Sequence of operation: power up to starting

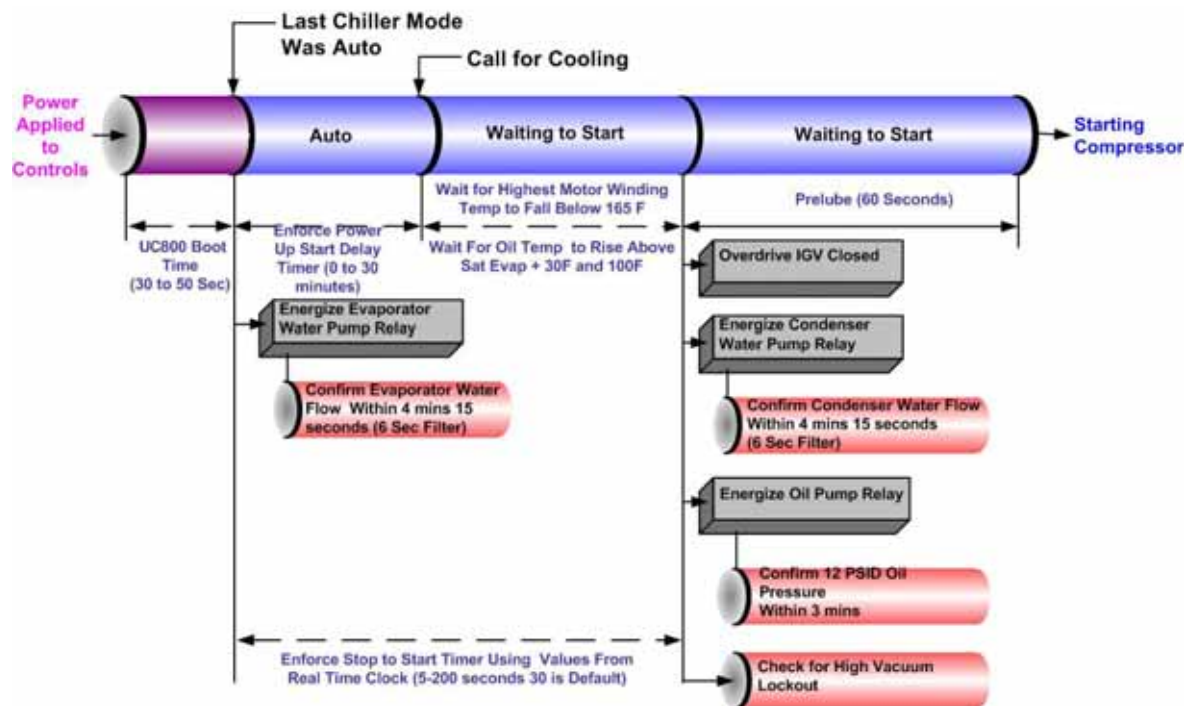

Now that the compressor motor is running in the “Delta” configuration, the inlet guide vanes will modulate, opening and closing to the chiller load variation by operation of the stepper vane motor actuator to satisfy

chilled water setpoint. The chiller continues to run in its appropriate mode of operation: Normal, Softload, Limit Mode, and so on (see [Figure 39](#)).

Start-up and Shut-down

If the chilled water temperature drops below the chilled water set point by an amount set as the “differential to stop” setpoint, a normal chiller stop sequence is initiated as follows:

1. The inlet guide vanes are driven closed (up to 50 seconds).
2. After the inlet guide vanes are closed, the stop relay and the condenser water pump relays open to turn off.

Figure 39. Sequence of operation: running

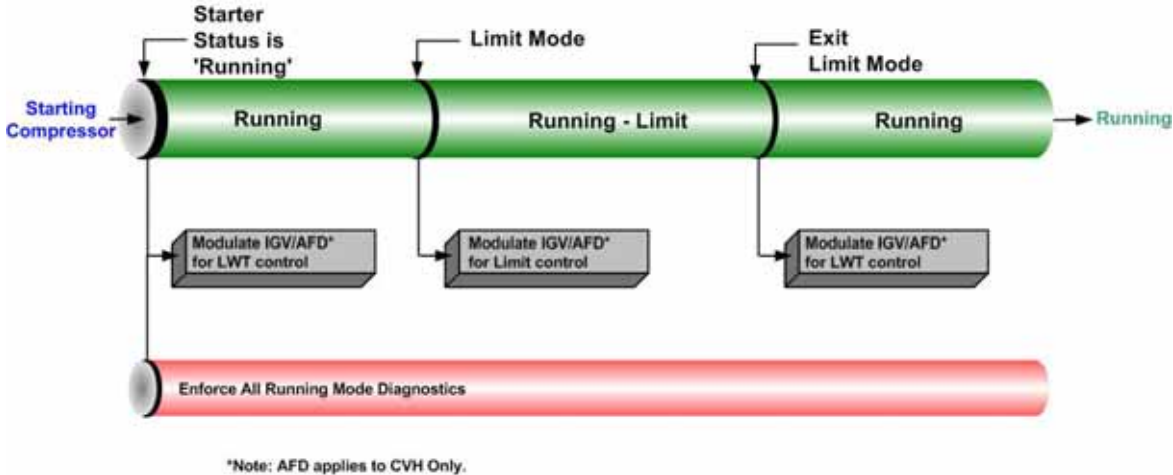

The oil and refrigerant pump motor will continue to run for 3 minutes post-lube while the compressor coasts to a stop. The chilled water pump will continue to run while the main processor module monitors leaving chilled water temperature preparing for the next compressor motor start based on the “differential to start” setpoint.

Figure 40, p. 62 illustrates this sequence.

Figure 40. Sequence of operation: satisfied setpoint

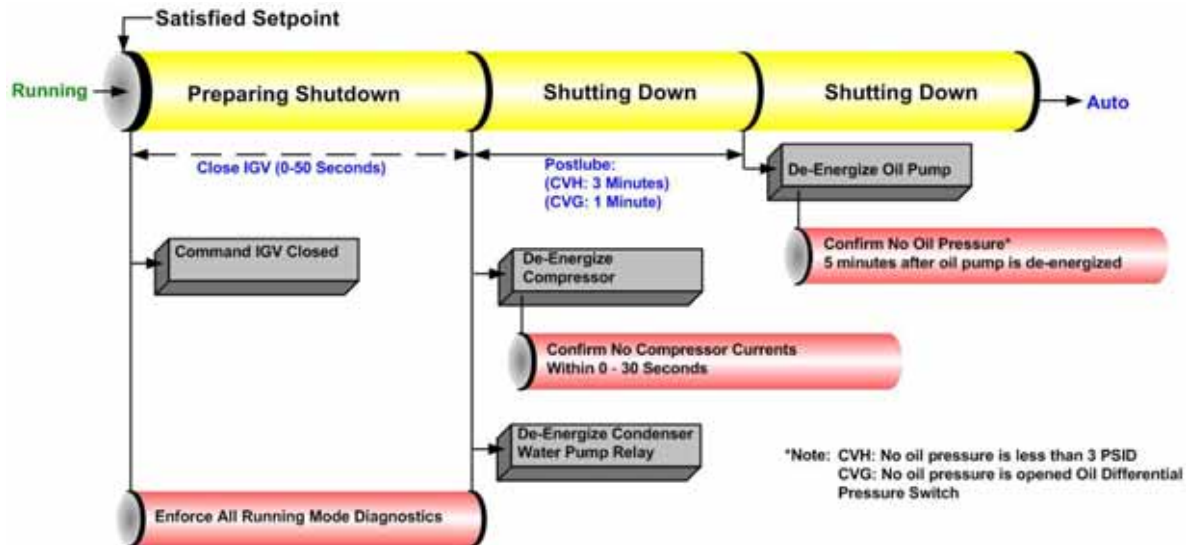

If the STOP key is pressed on the operator interface, the chiller will follow the same stop sequence as above except the chilled water pump relay will also open and stop the chilled water pump after the chilled water pump delay timer has timed out after compressor shut down (see Figure 41).

If the “Immediate Stop” is initiated, a panic stop occurs which follows the same stop sequence as pressing the STOP key once except the inlet guide vanes are not

sequence closed and the compressor motor is immediately turned off.

Figure 41. Sequence of operation: normal shut-down to stopped and run inhibit

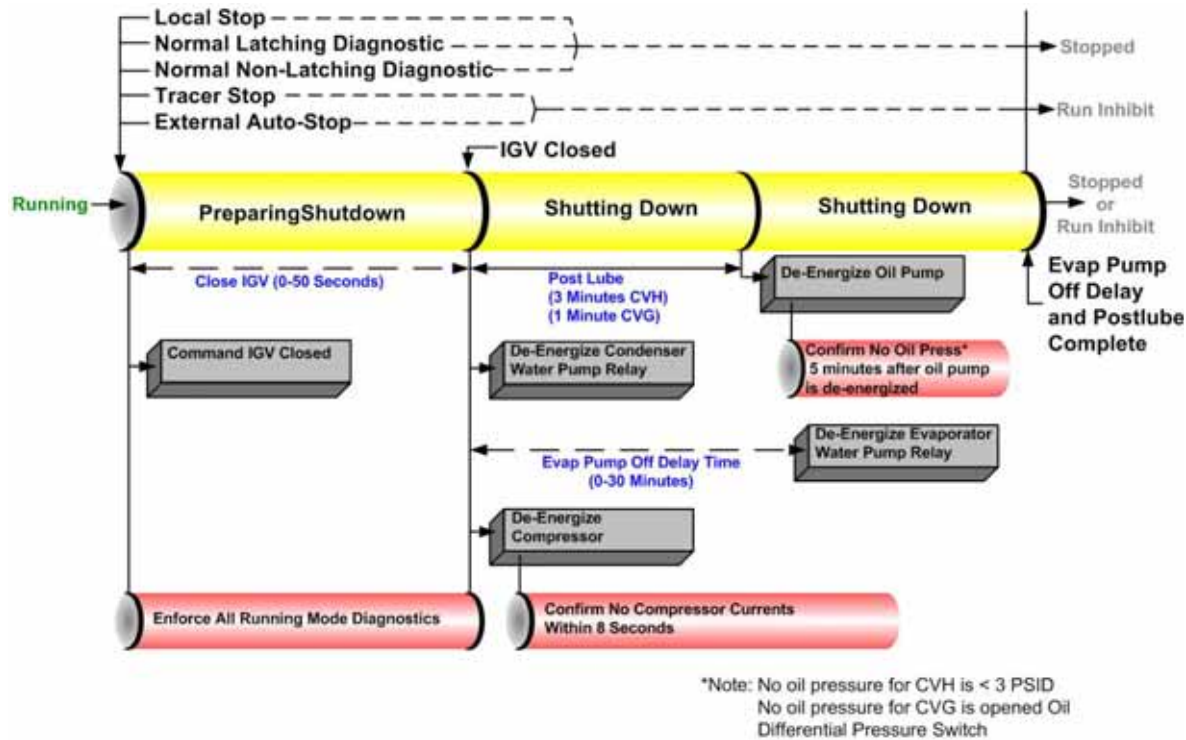

Power Up Diagram

Figure 38, p. 61 illustrates Tracer AdaptiView during a power up of the main processor. This process takes from 30 to 50 seconds depending on the number of installed Options. On all power ups, the software model always will transition through the Stopped software state independent of the last mode. If the last mode before power down was Auto, the transition from Stopped to Starting occurs, but it is not apparent to the user.

Ice Machine Control

The control panel provides a service level Enable or Disable menu entry for the Ice Building feature when the Ice Building option is installed. Ice Building can be entered from Front Panel, or if hardware is specified the control panel will accept either an isolated contact closure 1A19 Terminals J2-1 and J2-2 (Ground)) or a remote communicated input (BAS) to initiate the ice building mode where the unit runs fully loaded at all times. Ice building will be terminated either by opening the contact or based on entering evaporator fluid temperature. The control panel will not permit the Ice Building mode to be entered again until the unit is switched to the non-ice building mode and back into the ice building mode. It is not acceptable to reset the chilled water setpoint low to achieve a fully loaded compressor. When entering ice building, the compressor will be loaded at its maximum rate and when leaving ice building the compressor will be unloaded at its maximum rate. While loading and

unloading the compressor, all surge detection will be ignored. While in the ice building mode, current limit setpoints less than the maximum will be ignored. Ice Building can be terminated by one of the following means:

- Front panel disable.
- Opening the external Ice. Contacts/ Remote communicated input (BAS).
- Satisfying an evaporator entering fluid temperature setpoint (default is 27°F [-2.8°C]).
- Surging for 7 minutes at full open IGV.

Start-up and Shut-down

Figure 42. Sequence of operation: ice making: running to ice making

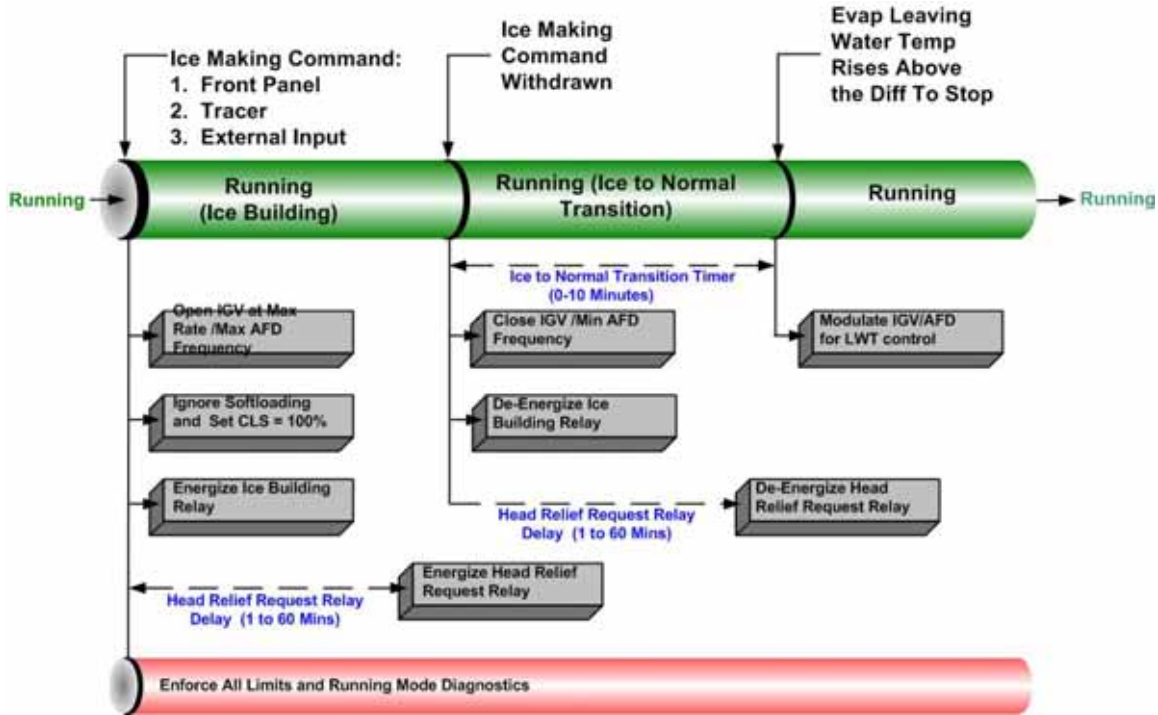
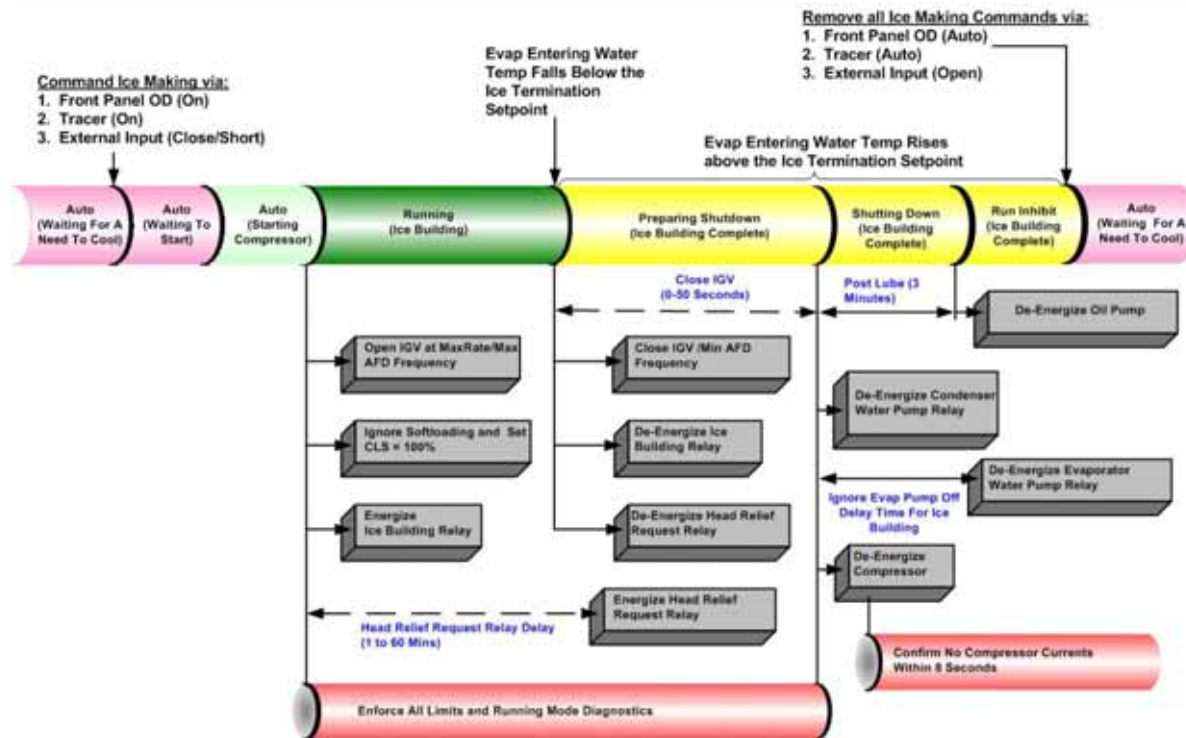

Figure 43. Sequence of operation: ice making: stopped to ice to ice building complete



Free Cooling Cycle

Based on the principle that refrigerant migrates to the coldest area in the system, the free cooling option adapts the basic chiller to function as a simple heat exchanger. However, it does not provide control of the leaving chilled water temperature.

If condenser water is available at a temperature lower than the required leaving chilled water temperature, the operator interface must remain in AUTO and the operator starts the free cooling cycle by enabling the Free cooling mode in the Tracer AdaptiView Feature Settings group of the operator interface, or by means of a BAS request. The following components must be factory-installed or field-installed to equip the unit for free cooling operation:

- a refrigerant gas line, and electrically-actuated shutoff valve, between the evaporator and condenser,
- a valved liquid return line, and electrically-actuated shutoff valve, between the condenser sump and the evaporator,
- a liquid refrigerant storage vessel (larger economizer), and
- additional refrigerant.

When the chiller is changed over to the free cooling mode, the compressor will shut down if running, the shutoff valves in the liquid and gas lines open; unit control logic prevents the compressor from energizing during free cooling. Liquid refrigerant then drains (by gravity) from the storage tank into the evaporator and floods the tube bundle. Since the temperature and pressure of the refrigerant in the evaporator are higher than in the condenser (i.e., because of the difference in water temperature), the refrigerant in the evaporator vaporizes and travels to the condenser, cooling tower water causes the refrigerant to condense on the condenser tubes, and flow (again, by gravity) back to the evaporator.

This compulsory refrigerant cycle is sustained as long as a temperature differential exists between condenser and evaporator water. The actual cooling capacity provided by the free cooling cycle is determined by the difference between these temperatures which, in turn, determines the rate of refrigerant flow between the evaporator and condenser shells.

If the system load exceeds the available free cooling capacity, the operator must manually initiate changeover to the mechanical cooling mode by disabling the free cooling mode of operation. The gas and liquid line valves then close and compressor operation begins (see [Figure 38, p. 61](#), beginning at Auto mode). Refrigerant gas is drawn out of the evaporator by the compressor, where it is then compressed and discharged to the condenser. Most of the condensed refrigerant initially follows the path of least resistance by flowing into the storage tank. This tank is vented to the economizer sump through a small bleed line; when the storage tank is full, liquid refrigerant must flow through the bleed line restriction. Because the pressure drop through the bleed line is greater than that of

the orifice flow control device, the liquid refrigerant flows normally from the condenser through the orifice system and into the economizer.

Free Cooling (FRCL)

To enable Free Cooling Mode:

1. Install and commission Free Cooling.
2. Enable the Free Cooling mode in the Tracer AdaptiView Settings menu.
3. Press AUTO, and if used, close the external binary input switch (connected to 1A20 J2-1 to 2) while the chiller is in AUTO.

Note: Free Cooling cannot be entered if the chiller is in "STOP."

If the chiller is in AUTO and not running, the condenser water pump will start. After condenser water flow is proven, Relay Module 1A11 will energize operating the Free Cooling Valves 4B12 and 4B13. The Free Cooling Valves End Switches must open within 3 minutes, or an MMR diagnostic will be generated. Once the Free Cooling Valves End Switches open, the unit is in the Free Cooling mode. If the chiller is in AUTO and running powered cooling, the chiller will initiate a friendly shut down first (Run: Unload, Post Lube, and drive vanes closed). After the vanes have been overdriven closed and condenser water flow proven, the Free Cooling relays will be energized. To disable Free Cooling and return to Powered Cooling, either disable the Free Cooling Mode in the Tracer AdaptiView settings menu if used to enable Free Cooling or OPEN the external binary input switch to the 1A20 Module if it was used to enable Free Cooling. Once Free Cooling is disabled, the Free Cooling relays Relay Module 1A11 will de-energize allowing the Free Cooling valves to close. The Free Cooling valves end switches must close within 3 minutes or an MMR diagnostic is generated. Once the end switches close the chiller will return to AUTO and powered cooling will resume if there is a call for cooling based on the differential to start.

Notes:

- *The manual control of the inlet guide vanes is disabled while in the Free Cooling Mode and the compressor is prevented from starting by the control logic.*
- *The relay at 1A11-J2-4 to 6 is a FC auxiliary relay and can be used as required.*

Hot Gas Bypass (HGBP)

The hot gas bypass (HGBP) control option is designed to minimize machine cycling by allowing the chiller to operate stably under minimum load conditions. In these situations, the inlet guide vanes are locked at a preset minimum position, and unit capacity is governed by the HGBP valve actuator. Control circuitry is designed to allow both the inlet guide vanes and the HGBP valve to close for unit shut-down. After a chiller starts and is running the inlet guide vanes will pass through the HGBP Cut-In-Vane

Start-up and Shut-down

position as the chiller starts to load. As the chiller catches the load and starts to unload, the inlet guide vanes will close to the HGBP Cut-In Vane position. At this point the movement of the inlet guide vanes is stopped and further loading/unloading of the chiller is controlled by the opening/closing of the HGBP Valve (4M5). When the control algorithm determines the chiller to be shut down, the inlet guide vanes will be driven fully closed, and the HGBP valve will be driven closed. After the inlet guide vanes are fully closed the chiller will shut down in the Friendly mode. Chillers with HGBP have a discharge temperature sensor (4R16) monitoring the discharge gas temperature from the compressor. If this temperature exceeds 200°F (93.3°C), the chiller will shut off on a MAR diagnostic. The chiller will reset automatically when this temperature drops 50°F (10.0°C) below the trip-point. HGBP is enabled in the Features menu settings Group of the Tracer AdaptiView Menus by enabling the option. The setting the HGBP Cut-In Vane Position is setup at unit commissioning via the service tool.

Hot Water Control

Occasionally CTV chillers are selected to provide heating as a primary mission. With hot water temperature control, the chiller can be used as a heating source or cooling source. This feature provides greater application flexibility. In this case the operator selects a hot water temperature and the chiller capacity is modulated to maintain the hot water setpoint. Heating is the primary mission and cooling is a waste product or is a secondary mission. This type of operation requires an endless source of evaporator load (heat), such as well or lake water. The chiller has only one condenser.

Note: Hot water temperature control mode does not convert the chiller to a heat pump. Heat pump refers to the capability to change from a cooling-driven application to a heating-driven application by changing the refrigerant path on the chiller. This is impractical for centrifugal chillers as it would be much easier to switch over the water side.

This is NOT heat recovery. Although this feature could be used to recover heat in some form, a heat recovery unit has a second heat exchanger on the condenser side.

The Tracer AdaptiView Main Processor provides the hot water temperature control mode as standard. The leaving condenser water temperature is controlled to a hot water setpoint between 80°F and 140°F (26.7° and 60.0°C). The leaving evaporator water temperature is left to drift to satisfy the heating load of the condenser. In this application the evaporator is normally piped into a lake, well, or other source of constant temperature water for the purpose of extracting heat. In hot water temperature control mode all the limit modes and diagnostics operate as in normal cooling with one exception; the leaving condenser water temperature sensor is an MMR diagnostic when in hot water temperature control mode.

(It is an informational warning in the normal cooling mode.)

In the hot water temperature control mode the differential-to-start and differential-to-stop setpoints are used with respect to the hot water setpoint instead of with the chilled water setpoint. The control panel provides a separate entry at the Tracer AdaptiView to set the hot water setpoint. Tracer AdaptiView is also able to set the hot water setpoint. In the hot water mode the external chilled water setpoint is the external hot water setpoint; that is, a single analog input is shared at the 1A16-J2-5 to 6 (ground).

An external binary input to select external hot water control mode is on the EXOP OPTIONAL module 1A18 terminals J2-3 to J2-4 (ground). Tracer AdaptiView also has a binary input to select chilled water control or hot water temperature control. There is no additional leaving hot water temperature cutout; the HPC and condenser limit provide for high temperature and pressure protection.

In hot water temperature control the softloading pulldown rate limit operates as a softloading pullup rate limit. The setpoint for setting the temperature rate limit is the same setpoint for normal cooling as it is for hot water temperature control. The hot water temperature control feature is not designed to run with HGBP, AFD, free cooling, or ice making.

The factory set PID tuning values for the leaving water temperature control are the same settings for both normal cooling and hot water temperature control.

Heat Recovery Cycle

Heat recovery is designed to salvage the heat that is normally rejected to the atmosphere through the cooling tower, and put it to beneficial use. For example, a high-rise office building may require simultaneous heating and cooling during the winter months. With the addition of a heat recovery cycle, heat removed from the building cooling load can be transferred to areas of the building that require heat.

Note: The heat recovery cycle is possible only if a cooling load exists to act as a heat source.

To provide a heat recovery cycle, a heat-recovery condenser is added to the unit. Though physically identical to the standard cooling condenser, the heat-recovery condenser is piped into a heat circuit rather than to the cooling tower. During the heat recovery cycle, the unit operates just as it does in the cooling only mode except that the cooling load heat is rejected to the heating water circuit rather than to the cooling tower water circuit. When hot water is required, the heating water circuit pumps energize. Water circulated through the heat-recovery (or auxiliary) condenser tube bundle by the pumps absorbs cooling-load from the compressed refrigerant gas discharge by the compressor. The heated water is then used to satisfy heating requirements.

Auxiliary Condensers

Unlike the heat-recovery condenser (which is designed to satisfy comfort heating requirements), the auxiliary condenser serves a preheat function only, and is used in those applications where hot water is needed for use in kitchens, lavatories, etc. While the operation of the auxiliary condenser is physically identical to that of the heat-recovery condenser, it is comparatively smaller in size, and its heating capacity is not controlled. Trane does not recommend operating the auxiliary condenser alone because of its small size.

Control Panel Devices and Unit-Mounted Devices

Unit Control Panel

Safety and operating controls are housed in the unit control panel, the starter panel, and the purge control panel. The control panel operator interface and main processor is called Tracer AdaptiView and is located on an adjustable arm connected to the base of the control panel. For more information about operating Tracer AdaptiView, refer to *Tracer AdaptiView™ Display for Water-Cooled CenTraVac™ Chillers Operations Guide* (CTV-SVU01*-EN, or the most recent version).

The control panel houses several other controls modules called panel mounted LLID (Low Level Intelligent Device), power supply, terminal block, fuse, circuit breakers, and transformer. The IPC (Interprocessor communication) bus allows the communications between LLIDs and the main processor. Unit mounted devices are called frame mounted LLIDs and can be temperature sensors or pressure transducers. These and other functional switches provide analog and binary inputs to the control system.

User-Defined Language Support

Tracer AdaptiView is capable of displaying English text or any of twenty-four other languages. Switching languages is simply accomplished from a language settings menu.

Unit Start-up and Shut-down Procedures

⚠ WARNING

Live Electrical Components!

Failure to follow all electrical safety precautions when exposed to live electrical components could result in death or serious injury. During installation, testing, servicing and troubleshooting of this product, it may be necessary to work with live electrical components. Have a qualified licensed electrician or other individual who has been properly trained in handling live electrical components perform these tasks.

⚠ WARNING

Toxic Hazards!

Do not allow the chiller to increase above 110°F (43.3°C) in temperature while unit is off. Failure to prevent high chiller temperature will cause the inside pressure to rise:

- **Do not run evaporator water pump longer than 30 minutes after the chiller is shut down.**
- **Ensure that the evaporator is isolated from the hot water loop before changeover to heating mode.**

The rupture disk is designed to relieve and discharge the refrigerant from the unit if the pressure in the evaporator exceeds 15 psig (103.4 kPaG). A significant release of refrigerant into a confined space due to a rupture disk failure could displace available oxygen to breathe and cause possible asphyxiation. Should a rupture disk fail, evacuate the area immediately and contact the appropriate rescue or response authority. Failure to follow instructions could result in death or serious injury.

Daily Unit Start-up

1. Verify the chilled water pump and condenser water pump starter are in ON or AUTO.
2. Verify the cooling tower is in ON or AUTO.
3. Check the oil tank oil level; the level must be visible in or above the lower sight glass. Also, check the oil tank temperature; normal oil tank temperature before start-up is 140°F to 145°F (60.0°C to 62.8°C).

Notes:

- *The oil heater is energized during the compressor off cycle. During unit operation, the oil tank heater may be de-energized.*
 - *If the chiller is equipped with the free cooling option, ensure that the free cooling option is disabled in the Chiller Settings menu.*
4. Check the chilled water setpoint and readjust it, if necessary, in the Chiller Settings menu.
 5. If necessary, readjust the current limit setpoint in the Chiller Setpoints menu.
 6. Press AUTO.

The control panel also checks compressor motor winding temperature, and a start is initiated after a minimum restart inhibit time if the winding temperature is less than 265°F (129.4°C). The chilled water pump relay is energized and evaporator water flow is proven. Next, the control panel checks the leaving evaporator water temperature and compares it to the chilled water setpoint. If the difference between these values is less than the start differential setpoint, cooling is not needed.

If the control panel determines that the difference between the evaporator leaving water temperature and chilled water setpoint exceeds the start differential setpoint, the



Start-up and Shut-down

unit enters the initiate Start Mode and the oil refrigerant pump and the condenser water pump are started. If flow is not initially established within 4 minutes 15 seconds of the condenser pump relay energization, an automatically resetting diagnostic “Condenser Water Flow Overdue” shall be generated which terminates the prestart mode and de-energizes the condenser water pump relay. This diagnostic is automatically reset if flow is established at any later time.

Note: This diagnostic does not automatically reset if Tracer AdaptiView is in control of the condenser pump through its condenser pump relay, since it is commanded off at the time of the diagnostic. It may reset and allow normal chiller operation if the pump was controlled from some external source.

When less than 5 seconds remain on the restart inhibit, the pre-start starter test is conducted on wye-delta starters. If faults are detected, the unit's compressor will not start, and a diagnostic will be generated. If the compressor motor starts and accelerates successfully, Running appears on the display. If the purge is set to AUTO, the purge will start running and will run as long as the chiller is running.

Note: If a manual reset diagnostic condition is detected during start-up, unit operation will be locked out, and a manual reset is required before the start-up sequence can begin again. If the fault condition has not cleared, the control panel will not permit restart.

When the cooling requirement is satisfied, the control panel originates a Shutting down signal. The inlet guide vanes are driven closed for 50 seconds, the compressor stops, and the unit enters a 3-minute post-lube period. The evaporator pump may continue to run for the amount of time set using Tracer AdaptiView.

Once the post-lube cycle is done, the unit returns to auto mode.

Seasonal Unit Start-up

1. Close all drain valves, and reinstall the drain plugs in the evaporator and condenser headers.
2. Service the auxiliary equipment according to the start-up and maintenance instructions provided by the respective equipment manufacturers.
3. Fill and vent the cooling tower, if used, as well as the condenser and piping. At this point, all air must be removed from the system (including each pass). Then close the vents in the condenser waterboxes.
4. Open all of the valves in the evaporator chilled water circuit.
5. If the evaporator was previously drained, fill and vent the evaporator and chilled water circuit. When all air is removed from the system (including each pass), close the vent valves in the evaporator waterboxes.
6. Lubricate the external vane control linkage as needed.

7. Check the adjustment and operation of each safety and operating control.
8. Close all disconnect switches.
9. Perform instructions listed in [“Daily Unit Start-up” p. 67](#).

Daily Unit Shut-down

Note: Also refer to [Figure 41, p. 63](#).

1. Press STOP.
2. After compressor and water pumps shut-down, the operator may turn Pump Contactors to OFF or open pump disconnects.

Seasonal Unit Shut-down

Important: Control power disconnect switch must remain closed to allow oil sump heater operation. Failure to do this will allow refrigerant to condense in the oil pump.

1. Open all disconnect switches except the control power disconnect switch.
2. Drain the condenser piping and cooling tower, if used. Rinse with clean water.
3. Remove the drain and vent plugs from the condenser headers to drain the condenser. Air dry bundle of residual water.
4. Once the unit is secured for the season, the maintenance procedures described [Table 19, p. 70](#) and [Table 20, p. 71](#) should be performed by qualified Trane service technicians.

Note: During extended shut-down periods, be sure to operate the purge unit for a two-hour period every two weeks. This will prevent the accumulation of air and noncondensables in the machine. To start the purge, change the purge mode to ON in the unit control “Settings Purge” menu. Remember to turn the purge mode to “Adaptive” after the two-hour run time.



Recommended Maintenance

⚠ WARNING

Hazardous Voltage w/Capacitors!

Failure to disconnect power and discharge capacitors before servicing could result in death or serious injury. Disconnect all electric power, including remote disconnects and discharge all motor start/run capacitors before servicing. Follow proper lockout/tagout procedures to ensure the power cannot be inadvertently energized. For variable frequency drives or other energy storing components provided by Trane or others, refer to the appropriate manufacturer's literature for allowable waiting periods for discharge of capacitors. Verify with an appropriate voltmeter that all capacitors have discharged.

For additional information regarding the safe discharge of capacitors, see PROD-SVB06*-EN

NOTICE:

Check Purge Run-Time for Unit Hermetic Integrity!

If frequent purging is required, failure to monitor purge pumpout rate, identify and correct source of air or water leak as soon as possible could shorten chiller life expectancy, due to moisture contamination caused by leakage.

NOTICE:

Do Not Use Non-Compatible Parts or Materials!

Use of non-compatible parts or materials could result in equipment damage. Only genuine Trane® replacement components with identical Trane part numbers should be used in Trane CenTraVac chillers. Trane assumes no responsibility for damages resulting from the use of non-compatible parts or materials.

This section describes the basic chiller preventive maintenance procedures, and recommends the intervals at which these procedures should be performed. Use of a periodic maintenance program is important to ensure the best possible performance and efficiency from a CenTraVac chiller.

Recommended purge maintenance procedures are detailed in *Operation and Maintenance Guide: EarthWise™ Purge System with Tracer AdaptiView™ Control for Water-Cooled CenTraVac™ Chillers* (PRGD-SVX01*-EN, or the most recent version).

Record Keeping Forms

An important aspect of the chiller maintenance program is the regular completion of records. Refer to ["Forms and Check Sheets," p. 79](#) for copies of the recommended

forms. When filled out accurately by the machine operator, the completed logs can be reviewed to identify any developing trends in the chiller's operating conditions. For example, if the machine operator notices a gradual increase in condensing pressure during a month's time, he can systematically check, then correct the possible cause of this condition.

Normal Operation

Table 18. Normal operation

Operating Characteristic	Normal Reading
Approximate Evaporator Pressure	6 to 9 psia (41.4 to 62.1 kPaA) / -9 to -6 psig (-62.1 to -41.4 kPaG)
Approximate Condenser Pressure ^{(a), (b)}	17 to 27 psia (117.2 to 182.2 kPaA) / 2 to 12 psig (13.8 to 82.7 kPaG) (standard condenser)
Oil Sump Temperature Unit not running	140°F to 176°F (60.0°C to 80.0°C)
Oil Sump Temperature Unit running	95°F to 162°F (35.0°C to 72.2°C)
Oil Sump Differential Oil Pressure ^(c)	18 to 22 psid (124.1 to 151.7 kPaD)

- (a) Condenser pressure is dependent on condenser water temperature, and should equal the saturation pressure of HCFC-123 at a temperature above that of leaving condenser water at full load.
- (b) Normal pressure readings for ASME condenser exceed 12 psig (82.7 kPaG).
- (c) Oil tank pressure: -9 to -6 psig (-62.1 to -41.4 kPaG). Discharge oil pressure: 7 to 15 psig (48.3 to 103.4 kPaG).

NOTICE:

Equipment Damage!

Failure to remove the strain relief with the sensor could result in equipment damage. Do NOT attempt to pull sensor bulb through the strain relief; always remove the entire strain relief with the sensor.



Recommended Maintenance

Table 19. Recommended maintenance

Daily	Every 3 months	Every 6 months	Annually ^(a) , ^(b)
Check the chiller's evaporator and condenser pressures, oil tank pressure, differential oil pressure and discharge oil pressure. Compare the readings with the values provided in Table 18, p. 69 .			
Check the oil level in the chiller oil sump using the two sight glasses provided in the oil sump head. When the unit is operating, the oil level should be visible in the lower sight glass.			
Complete logs on a daily basis.	Clean all water strainers in the water piping system.	Lubricate the vane control linkage bearings, ball joints, and pivot points.	
		Lubricate vane operator tang O-rings.	
		Operate the tang operators manually and check for any abnormalities.	
		Lubricate the oil filter shutoff valve O-rings.	
		Drain contents of the rupture disk and purge discharge ventline drip-leg into an evacuated waste container. Do this more often if the purge is operated excessively. Apply oil to any exposed metal parts to prevent rust.	
			Shut down the chiller once each year to check the items listed on the " CVHE, CVHF, CVHG Annual Inspection List " (refer to " Forms and Check Sheets ," p. 79).
			Perform the annual maintenance procedures referred to in <i>Operation and Maintenance Guide: EarthWise™ Purge System with Tracer AdaptiView™ Control for Water-Cooled CenTraVac™ Chillers</i> (PRGD-SVX01*-EN).
			Use an ice water bath to verify the accuracy of the evaporator refrigerant temperature sensor (4R10). If the sensor is exposed to temperature extremes outside its normal operating range (0°F to 90°F [-17.8°C to 32.2°C]), check its accuracy at six-month intervals.
			Inspect the condenser tubes for fouling; clean if necessary.
			Inspect and clean the ifm efector® flow detection sensors. Use Scotch-Brite® or other non-abrasive material to clean scale; do NOT use steel wool, which could cause the probe to rust.
			Submit a sample of the compressor oil to a Trane-qualified laboratory for comprehensive analysis.
			Measure the compressor motor winding resistance to ground; a qualified service technician should conduct this check to ensure that the findings are properly interpreted. Contact a qualified service organization to leak-test the chiller; this procedure is especially important if the system requires frequent purging.

(a) Every three years, use a nondestructive tube test to inspect the condenser and evaporator tubes. It may be desirable to perform tube tests on these components at more frequent intervals, depending upon chiller application. This is especially true of critical process equipment.

(b) Contact a qualified service organization to determine when to conduct a complete examination of the unit to discern the condition of the compressor and internal components. Check the following: chronic air leaks (which can cause acidic conditions in the compressor oil and result in premature bearing wear) and evaporator or condenser water tube leaks (water mixed with the compressor oil can result in bearing pitting, corrosion, or excessive wear).

Table 20. Recommended maintenance of optional features

Feature	Every 3 months	Every 6 months	Annually
Waterbox Coatings	Inspect waterbox coatings within the first 1–3 months to determine a required maintenance schedule for your job site. Refer to “ Waterbox and Tubesheet Protective Coatings ,” p. 73 for more information.		
Waterbox Anodes	Inspect waterbox anodes within the first 1–3 months to determine a required maintenance schedule for your job site. Refer to “ Sacrificial Anodes ,” p. 73 for more information.		
Gantries			Lubricate the gantries annually. Use ConocoPhillips MegaPlex® XD3 (gray in color), LPS® MultiPlex Multi-Purpose (blue in color), or equivalent.
Hinges			Lubricate the hinges annually. Use ConocoPhillips MegaPlex® XD3 (gray in color), LPS® MultiPlex Multi-Purpose (blue in color), or equivalent.

Recommended Compressor Oil Change

After the first six months of accumulated operation, or after 1,000 hours operation—whichever comes first—it is recommended to change the oil and filter. After this oil change, it is recommended to subscribe to the Trane annual oil analysis program rather than automatically change the oil as part of scheduled maintenance. Change the oil only if indicated by the oil analysis. Use of an oil analysis program will reduce the chiller’s overall lifetime waste oil generation and minimize refrigerant emissions. The analysis determines system moisture content, acid level, and wear metal content of the oil, and can be used as a diagnostic tool. The oil analysis should be performed by a qualified laboratory that is experienced in refrigerant and oil chemistry and in the servicing of Trane® centrifugal chillers.

In conjunction with other diagnostics performed by a qualified service technician, oil analyses can provide valuable information on the performance of the chiller to help minimize operating and maintenance costs and maximize its operating life. A drain fitting is installed after the oil filter for obtaining oil samples.

Notes:

- Use only Trane OIL00022. A full oil change is 9 gallons (34.1 L) of OIL00022.
- One spare oil filter is provided with each new chiller. If not used earlier, use at first recommended oil and filter change.
- This recommended oil change is not covered by factory warranty.

Purge System

The use of low-pressure refrigerant in CenTraVac chillers permits any section of the unit to be below atmospheric pressure, regardless of whether the unit is running. This creates an environment in which air or moisture could enter the unit. If these noncondensables are allowed to

accumulate while the chiller is running, they become trapped in the condenser; this situation increases condensing pressure and compressor power requirements, and reduces the chiller’s efficiency and cooling capacity. Therefore, proper maintenance of the purge system is required.

The Trane EarthWise™ Purge is the only purge system available for the CenTraVac chiller. The purge is designed to remove noncondensable gases and water from the refrigeration system. EarthWise Purge unit operation, maintenance and troubleshooting is covered by a separate operation and maintenance manual, which may be obtained from the nearest Trane office.

Leak Checking Based on Purge Pump Out Time

Use the following formula to calculate the annual refrigerant leakage rate based on the daily purge pump out time and the unit refrigerant charge.

Formula: % annual leakage rate = [(X min/day) * (0.0001 lb R-123/min) / (Y lb)] * 100

- X = minutes/day of purge pump out operation
- Y = initial refrigerant charge

Figure 44 has been developed to aid in determining when to do a leak check of a chiller based on the purge pump out time and unit size. This figure depicts normal purge pump-out times, small leaks and large leaks based on the chiller tonnage.

If the purge pump-out time is in the small leak region, then a leak check should be performed and all leaks repaired at the earliest convenience. If the purge pump-out time is in the large leak region, a thorough leak check of the unit should be performed immediately to find and fix the leaks.

Figure 44. Purge operation under typical and leak conditions

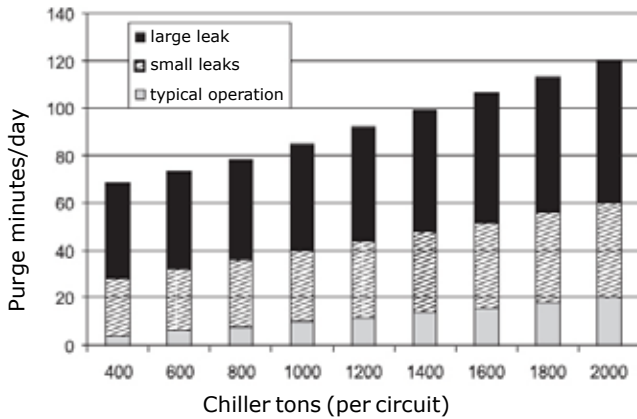

Long Term Unit Storage

Contact your local Trane service agency for recommendations for storage requirements for chillers to be removed from service in excess of a normal seasonal shut-down.

⚠️ WARNING

Refrigerant May Be Under Positive Pressure!

Failure to recover refrigerant to relieve pressure or the use of non-approved refrigerants, refrigerant substitutes, or refrigerant additives could result in an explosion which could result in death or serious injury or equipment damage. System contains oil and refrigerant and may be under positive pressure. Recover refrigerant to relieve pressure before opening the system. See unit nameplate for refrigerant type. Do not use non-approved refrigerants, refrigerant substitutes, or refrigerant additives.

NOTICE:

Freezing Tubes Hazard!

Failure to ensure that water is not present in tubes during evacuation could result in freezing tubes, damaging the chiller.

Refrigerant Charge

⚠️ WARNING

Refrigerant May Be Under Positive Pressure!

Failure to recover refrigerant to relieve pressure or the use of non-approved refrigerants, refrigerant substitutes, or refrigerant additives could result in an explosion which could result in death or serious injury or equipment damage. System contains oil and refrigerant and may be under positive pressure. Recover refrigerant to relieve pressure before opening the system. See unit nameplate for refrigerant type. Do not use non-approved refrigerants, refrigerant substitutes, or refrigerant additives.

Refer to *Installation, Operation, and Maintenance: Refrigerant Handling Guidelines - A Guide for the Service Technician's Conservation & Safe Handling of Low-Pressure Refrigerants in Trane® Chillers* (CTV-SVX05* -EN, or the most recent revision).

Leak Testing

⚠️ WARNING

Hazard of Explosion!

Failure to follow recommended safe leak test procedures could result in death or serious injury or equipment or property-only-damage. Never use an open flame to detect gas leaks. Explosive conditions may occur. Use a leak test solution or other approved methods for leak testing.

⚠️ WARNING

Hazardous Pressures!

Failure to follow these safety precautions could result in a sudden rise of pressure possibly resulting in a violent explosion which could result in death or serious injury. If a heat source is required to raise the tank pressure during removal of refrigerant from cylinders, use only warm water or heat blankets to raise the tank temperature. Do not exceed a temperature of 150°F. Do not, under any circumstances apply direct flame to any portion of the cylinder.

Important: If leak testing is required, contact a Trane service agency.

Recommended System Maintenance

NOTICE:

Proper Water Treatment!

The use of untreated or improperly treated water in a CenTraVac could result in scaling, erosion, corrosion, algae or slime. It is recommended that the services of a qualified water treatment specialist be engaged to determine what water treatment, if any, is required. Trane assumes no responsibility for equipment failures which result from untreated or improperly treated water, or saline or brackish water.

Condenser

Condenser tube fouling is indicated when the approach temperature (the difference between the condensing refrigerant temperature and the leaving condenser water temperature) is higher than predicted.

If the annual condenser tube inspection indicates that the tubes are fouled, two cleaning methods, mechanical and chemical, can be used to rid the tubes of contaminants. Use the mechanical cleaning method to remove sludge and loose material from smooth-bore tubes.

To clean other types of tubes including internally-enhanced types, consult a qualified service organization for recommendations.

Figure 45. Typical chemical cleaning setup

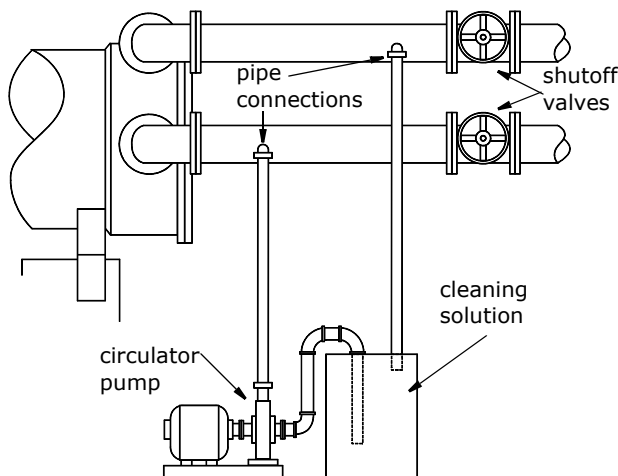

1. Follow all instructions in [“Waterbox Removal and Installation,” p. 75](#) to remove waterbox covers.
2. Work a round nylon or brass bristled brush (attached to a rod) in and out of each of the condenser water tubes to loosen the sludge.
3. Thoroughly flush the condenser water tubes with clean water.

Scale deposits are best removed by chemical means. Be sure to consult any qualified chemical house in the area (one familiar with the local water supply's

chemical mineral content) for a recommended cleaning solution suitable for the job.

Note: A standard condenser water circuit is composed solely of copper, cast iron, and steel.

NOTICE:

Unit Corrosion Damage!

Failure to follow proper procedures when using corrosive chemicals to clean water side of unit could result in corrosion damage to the unit and tubes. It is recommended that the services of a qualified chemical cleaning firm be used. Proper personal protective equipment as recommended by the chemical manufacturer should be used. Refer to the chemicals MSDS sheet for proper safety procedures.

Important: All of the materials used in the external circulation system, the quantity of the solution, the duration of the cleaning period, and any required safety precautions should be approved by the company furnishing the materials or performing the cleaning. Remember, however, that whenever the chemical tube cleaning method is used, it must be followed up with mechanical tube cleaning, flushing and inspection.

Evaporator

Since the evaporator is typically part of a closed circuit, it may not accumulate appreciable amounts of scale or sludge. Normally, cleaning every three years is sufficient. However, periodic inspection and cleaning is recommended on open evaporator systems, such as air washers.

Waterbox and Tubesheet Protective Coatings

Trane recommends that coated waterboxes/tubesheets—regardless of the type of protective coating included—be taken out of service within the first one to three months of operation for inspection. Any voids or defects identified upon inspection must be repaired. If the water quality is known to be highly supportive of corrosion (i.e., sea water, etc.), inspect the coating system at one month; if the water quality is known to be relatively benign (i.e., normal treated and clean condenser water), inspect the coating system within three months. Only when initial inspections show no problems are present should subsequent maintenance intervals be increased.

Sacrificial Anodes

The replacement schedule for the optional zinc or magnesium anodes can vary greatly with the aggressiveness of the water that is in the system. Some sites could require anode replacement every two to three months while other sites may require anode replacement every two to three years. Trane recommends that anode inspection for wear sometime within the first several months of the anodes being placed into service. If the



Recommended Maintenance

observed loss of anode material is small, then the interval between subsequent inspections can be lengthened. Replace the anode and/or shorten the inspection interval if the anode has lost 50 percent or more of its original mass. If anode depletion occurs very quickly, consult a water treatment specialist to determine if the anode material selected is correct for the application.

NOTICE:

Equipment Damage!

Failure to follow instructions could result in equipment damage. Do NOT use Teflon-based tape or paste on anode; a small amount of liquid sealant (Loctite® 242 or equivalent) may be applied to prevent leakage when installing an anode, but do not apply so much sealant that it prevents the necessary electrical connection between the anode and the waterbox.

As needed after draining the waterbox, use a 2-1/2 in. (63.5 mm) wrench to remove/install Trane-supplied waterbox anodes.



Waterbox Removal and Installation

Important: Only qualified technicians should perform the installation and servicing of this equipment.

outside the United States, refer to literature provided by the applicable manufacturing location.

Discussion

This section will discuss recommended hoist ring/clevises and lifting. Proper lifting technique will vary based on mechanical room layout.

- It is the responsibility of the person(s) performing the work to be properly trained in the safe practice of rigging, lifting, securing, and fastening of the waterbox.
- It is the responsibility of the person(s) providing and using the rigging and lifting devices to inspect these devices to ensure they are free from defect and are rated to meet or exceed the published weight of the waterbox.
- Always use rigging and lifting devices in accordance with the applicable instructions for such device.

2. Select the proper lift connection device from the [Table 23, p. 78](#). The rated lifting capacity of the selected lift connection device must meet or exceed the published weight of the waterbox. Verify the waterbox weight from the latest published literature.
3. Ensure that the lift connection device has the correct connection for the waterbox (e.g., thread type [course/fine, English/metric] and bolt diameter [English/metric]).
4. Properly connect the lift connection device to the waterbox. Refer to [Figure 46, p. 75](#) and ensure that the lift connection device is securely fastened.

CTV units—Install hoist ring on to the lifting connection on the waterbox. Torque to 100 ft·lb (135.6 N·m) for 3/4-in. (19.05-mm) threaded connections and 28 ft·lb (38.0 N·m) for 1/2-in. (12.7-mm) threaded connections.

Procedure

⚠ WARNING

Heavy Objects!

Failure to properly lift waterbox could result in death or serious injury. Each of the individual cables (chains or slings) used to lift the waterbox must be capable of supporting the entire weight of the waterbox. The cables (chains or slings) must be rated for overhead lifting applications with an acceptable working load limit. Refer to [Table 22, p. 77](#) for waterbox weights.

⚠ WARNING

Straight Vertical Lift Required!

Failure to properly lift waterbox in straight vertical lift could result in death or serious injury. The proper use and ratings for eyebolts can be found in ANSI/ASME standard B18.15. Maximum load rating for eyebolts are based on a straight vertical lift in a gradually increasing manner. Angular lifts will significantly lower maximum loads and should be avoided whenever possible. Loads should always be applied to eyebolts in the plane of the eye, not at some angle to this plane.

Review mechanical room limitations and determine the safest method or methods of rigging and lifting the waterboxes.

1. Determine the type and size of chiller being serviced. Refer to Trane nameplate located on chiller control panel.

Important: This literature contains rigging and lifting information only for Trane CTV chillers built in La Crosse. For Trane CTV chillers built

Figure 46. Waterbox rigging and lifting—condenser and evaporator connections

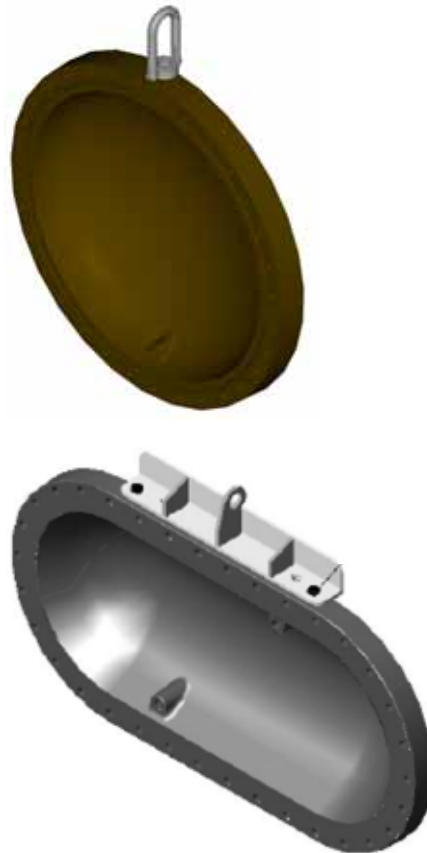

5. Disconnect water pipes, if connected.
6. Remove waterbox bolts.
7. Lift the waterbox away from the shell.

⚠ WARNING

Overhead Hazard!

Failure to follow instructions could result in death or serious injuries. Never stand below or in close proximity to heavy objects while they are suspended from, or being lifted by, a lifting device in case the object drops.

8. Store waterbox in a safe and secure location and position.

Note: Do not leave waterbox suspended from lifting device.

Reassembly

Once service is complete, the waterbox should be reinstalled on the shell following all previous procedures in reverse. Use new O-rings or gaskets on all joints after thoroughly cleaning each joint.

- Torque waterbox bolts (see [Table 21](#)).

Torque Requirements

Table 21. CenTraVac torque

Bolt Size in. (mm)	Gasket type O-ring ft·lb (N·m)	Flat ft·lb (N·m)
3/8	25 (33.9)	12-18 (16.3-24.4)
1/2	70 (94.9)	33-50 (44.7-67.8)
5/8	150 (203.4)	70-90 (94.9-122.0)
3/4	250 (339.0)	105-155 (142.4-210.2)

Table 22. CenTraVac waterbox weights

Shell Size	Description	Fabricated Non-Marine Waterbox, Welded Flat Plate		Non-Marine Cast Waterbox		Fabricated Non-Marine Waterbox Welded Dome		Marine Style Waterbox Cover	
		Weight lb (kg)	Lifting Connection	Weight lb (kg)	Lifting Connection	Weight lb (kg)	Lifting Connection	Weight lb (kg)	Lifting Connection
032	Evaporator, 150 psig (1034.2 kPaG)	265 (120)	3/4 - 10	NA	NA	NA	NA	176 (80)	1/2 - 13
	Evaporator, 300 psig (2068.4 kPaG)								
	Condenser, 150 psig (1034.2 kPaG)	NA	NA	176 (80)	1/2 - 13	NA	NA	176 (80)	1/2 - 13
	Condenser, 300 psig (2068.4 kPaG)	265 (120)	3/4 - 10	NA	NA	NA	NA	221 (100)	1/2 - 13
050	Evaporator, 150 psig (1034.2 kPaG)	397 (180)	3/4 - 10	397 (180)	Lifting Fixture	NA	NA	265 (120)	1/2 - 13
	Evaporator, 300 psig (2068.4 kPaG)	353 (160)	3/4 - 10	NA	NA	NA	NA	265 (120)	1/2 - 13
	Condenser, 150 psig (1034.2 kPaG)	265 (120)	1/2 - 13	265 (120)	1/2 - 13	NA	NA	265 (120)	1/2 - 13
	Condenser, 300 psig (2068.4 kPaG)	551 (250)	3/4 - 10	NA	NA	NA	NA	441 (200)	1/2 - 13
080	Evaporator, 150 psig (1034.2 kPaG)	662 (300)	3/4 - 10	662 (300)	Lifting Fixture	NA	NA	441 (200)	3/4 - 10
	Evaporator, 300 psig (2068.4 kPaG)	882 (400)	3/4 - 10	NA	NA	NA	NA	551 (250)	3/4 - 10
	Condenser, 150 psig (1034.2 kPaG)	551 (250)	3/4 - 10	551 (250)	3/4 - 10	NA	NA	441 (200)	1/2 - 13
	Condenser, 300 psig (2068.4 kPaG)	882 (400)	3/4 - 10	NA	NA	NA	NA	882 (400)	3/4 - 10
142	Evaporator, 150 psig (1034.2 kPaG)	882 (400)	3/4 - 10	NA	NA	NA	NA	662 (300)	3/4 - 10
	Evaporator, 300 psig (2068.4 kPaG)	1323 (600)	3/4 - 10	NA	NA	NA	NA	882 (400)	3/4 - 10
	Condenser, 150 psig (1034.2 kPaG)	1543 (700)	3/4 - 10	NA	NA	441 (200)	3/4 - 10	1323 (600)	3/4 - 10
	Condenser, 300 psig (2068.4 kPaG)	1985 (900)	3/4 - 10	NA	NA	NA	NA	1764 (800)	3/4 - 10
210	Evaporator, 150 psig (1034.2 kPaG)	1544 (700)	3/4 - 10	NA	NA	NA	NA	1323 (600)	3/4 - 10
	Evaporator, 300 psig (2068.4 kPaG)	2205 (1000)	3/4 - 10	NA	NA	NA	NA	1764 (800)	3/4 - 10
	Condenser, 150 psig (1034.2 kPaG)	2205 (1000)	3/4 - 10	NA	NA	662 (300)	3/4 - 10	1764 (800)	3/4 - 10
	Condenser, 300 psig (2068.4 kPaG)	2867 (1300)	3/4 - 10	NA	NA	NA	NA	2426 (1100)	3/4 - 10
250	Evaporator, 150 psig (1034.2 kPaG)	1985 (900)	3/4 - 10	NA	NA	NA	NA	1544 (700)	3/4 - 10
	Evaporator, 300 psig (2068.4 kPaG)	3087 (1400)	3/4 - 10	NA	NA	NA	NA	2205 (1000)	3/4 - 10
	Condenser, 150 psig (1034.2 kPaG)	2867 (1300)	3/4 - 10	NA	NA	662 (300)	3/4 - 10	2205 (1000)	3/4 - 10
	Condenser, 300 psig (2068.4 kPaG)	3528 (1600)	3/4 - 10	NA	NA	NA	NA	3087 (1400)	3/4 - 10

Note: Refer to product block identifier on the model number plate which identifies the evaporator and condenser shell sizes and the rated pressure. The designators are as follows:
 Evaporator Size = EVSZ Condenser Size = CDSZ Evaporator Pressure = EVPR Condenser Pressure = CDPDR
 Weights shown are maximum for waterbox size. Verify the waterbox from the latest published literature.



Connection Devices Information

Table 23. Connection devices

Unit	Product	Part Number	Order Information
CTV	Safety Hoist Ring 3/4-10	RNG01884	Contact Trane Parts Department
CTV	Safety Hoist Ring 1/2-13	RNG01885	Contact Trane Parts Department
CTV	Evap Lifting Fixture	BAR00400	Contact Trane Parts Department



Forms and Check Sheets

The following forms and check sheets are included for use with Trane start-up of CVHE, CVHF, and CVHG CenTraVac chillers. Forms and check sheets are used, as appropriate, for installation completion verification before Trane start-up is scheduled, and for reference during the Trane start-up.

Where the form or check sheet also exists outside of this publication as standalone literature, the literature order number is also listed.

- [“CenTraVac™ Installation Completion Check Sheet and Request for Trane Service” \(CTV-ADF001*-EN\)](#)
- [“CVHE, CVHF, CVHG Start-up Task List”](#)
- [“CVHE, CVHF, CVHG Annual Inspection List”](#)
- [“Operator Log”](#)



CenTraVac™ Installation Completion Check Sheet and Request for Trane Service

Important: A copy of this completed form must be submitted to the Trane service office that will be responsible for the start-up of the chiller. Start-up will NOT proceed unless applicable items listed in this form have been satisfactorily completed.

To: _____ Trane Service Office: _____

S.O. Number: _____ Serial Numbers: _____

Job/Project Name: _____

Address: _____

The following items are being installed and will be completed by: _____

Important: Start-up must be performed by Trane or an agent of Trane specifically authorized to perform start-up and warranty of Trane® products. Contractor shall provide Trane (or an agent of Trane specifically authorized to perform start-up) with notice of the scheduled start-up at least two weeks prior to the scheduled start-up. Equipment not started by Trane is not warranted by Trane.

Check box if the task is complete or if the answer is "yes."

1. CenTraVac

In place and piped.

Note: Do not insulate the CenTraVac chiller or adjacent piping prior to the chiller commissioning by Trane service personnel. The contractor is responsible for any foreign material left in the unit.

2. Piping

Chilled water piping connected to:

- CenTraVac
- Air handling units
- Pumps

Condenser and heat recovery condenser (as applicable) piping connected to:

- CenTraVac
- Pumps
- Cooling tower
- Heating loop (as applicable)

- Make-up water connected to cooling tower
- Water supply connected to filling system
- Systems filled

- Pumps run, air bled from system
- Strainers cleaned
- Rupture disk or RuptureGuard™ ventilation piping installed

3. Flow balancing valves installed

Leaving chilled water

Leaving condenser water

Optional heat recovery or auxiliary condenser water

4. Gauges, thermometers, and air vents

Installed on both sides of evaporator

Installed on both sides of condenser and heat recovery condenser (as applicable)

5. Wiring

Compressor motor starter has been furnished by Trane, or has been configured and installed in compliance with the appropriate Trane Starter by Others specification (available from your local Trane Sales Office)

- Full power available
- Interconnecting wiring, starter to panel (as required)
- External interlocks (flow switch, pumps auxiliary, etc.)
- Chiller motor connection (remote starters)

- Chilled water pump (connected and tested)
- Condenser water pump (connected and tested)
- Cooling tower fan rotation checked
- Heat recovery condenser water pump (as applicable)
- 115 Vac power available for service tools
- All controls installed and connected
- All magnetic starters installed and connected

Note: Do not make final remote starter-to-compressor motor connections until requested to do so by the Trane service representative!

6. Testing

Dry nitrogen available for pressure testing (for disassembled units)

Material and equipment available for leak testing, if necessary

7. Refrigerant on job site and in close proximity to chiller

Total amount in cylinders/drums: _____ (specify lb or kg) and fill in specifics below:

Number of cylinders/drums ____ of size _____ (specify lb or kg)

Number of cylinders/drums ____ of size _____ (specify lb or kg)

Note: After commissioning is complete, it is the installer's responsibility to transport empty refrigerant containers to an easily accessible point of loading to facilitate container return or recycling.

8. Systems can be operated under load conditions

9. Electrical, control man, and contractor's representative are available to evacuate, charge, and test the CenTraVac under serviceman's supervision

10. Equipment room

Does the equipment room have a refrigerant monitor/sensor capable of monitoring and alarming within the allowable exposure level of the refrigerant?

Does the equipment room have proper mechanical ventilation?

Does the installation have properly placed and operating audible and visual refrigerant alarms?

If it is required by local code, is a self-contained breathing apparatus available?

11. Owner awareness

Has the owner been fully instructed on the proper use and handling of refrigerant?

Does the owner have a copy of the MSDS for refrigerant?

Note: Additional time required to properly complete the start-up and commissioning, due to any incompleteness of the installation, will be invoiced at prevailing rates.

This is to certify that the Trane® equipment has been properly and completely installed, and that the applicable items listed above have been satisfactorily completed.

Checklist completed by (print name): _____

Signature: _____ Date: _____

In accordance with your quotation and our purchase order number _____, we will therefore require the presence of Trane service on this site, for the purpose of start-up and commissioning, by _____ (date).

Note: Minimum two-week advance notification is required to allow scheduling of the chiller start-up.

Additional comments/instructions:

This document and the information in it are the property of Trane, and may not be used or reproduced in whole or in part without written permission. Trane reserves the right to revise this publication at any time, and to make changes to its content without obligation to notify any person of such revision or change. All trademarks referenced in this document are the trademarks of their respective owners.



Trane optimizes the performance of homes and buildings around the world. A business of Ingersoll Rand, the leader in creating and sustaining safe, comfortable and energy efficient environments, Trane offers a broad portfolio of advanced controls and HVAC systems, comprehensive building services, and parts. For more information, visit www.Trane.com.

Trane has a policy of continuous product and product data improvement and reserves the right to change design and specifications without notice.





CVHE, CVHF, CVHG Start-up Task List

Start-up Tasks to be Performed By Trane

⚠ WARNING

Safety Alert!

In addition to the following tasks, you **MUST**:

- Follow all instructions in the chiller's *Installation, Operation, and Maintenance* manual, including warnings, cautions, and notices.
- Perform all required tasks in any applicable Service Alerts and Service Bulletins.
- Review and understand all information provided in Submittals and Design Specifications.

Failure to do so could result in death or serious injury.

General

- Inspect chiller for damage (shipping or rigging).
- Verify and record unit nitrogen holding charge pressure.
- Inspect water piping for proper installation.
 - Inspect strainers, flow sensing devices, isolation valves, pressure gauges, thermometer wells, flow balancing valves, vent cocks, and drains.
 - Inspect cooling tower piping.
- Verify proper clearances.
- Power wiring meets size requirement.
 - Verify proper voltage and amperage rating.
- Verify proper foundation installation.
- Verify unit isolator pads/springs have been installed.
- Verify low voltage circuits are isolated from high voltage circuits.
- Check equipment room for ventilation, refrigerant monitor, rupture disk piping, and PPE.

Note: All conditions which do not conform to the established requirements for unit installation must be corrected prior to start-up. Any non-conforming condition which is not corrected prior to start-up must be noted in the Non-Compliance Form (PROD-ADF001-EN) by the start-up technician; this information must also be signed by responsible site personnel before start-up and the completed Non-Compliance Form will become part of the start-up record, submitted with a Start-up Check Sheet and a Chiller Service Report.*

Pre-Start Operations

- Verify nitrogen holding charge.
- Calibrate the high pressure cutout control (HPC).
- Meg compressor motor.
- Confirm proper oil pump operation.
- Evacuate unit.
- Check condenser installation.
- Check evaporator installation.

NOTICE:

Do Not Apply Electrical Power to a Unit in a Vacuum!

Failure to disconnect power to units with inside-the-delta solid state starters during evacuation or when the unit is in a deep vacuum could cause compressor motor damage. Applying electrical power to a motor in a vacuum could cause damage to the motor. In addition, on units with inside-the-delta solid state starters, all power to the unit must be disconnected prior to evacuating the unit as line power is directly applied to the motor terminals 4, 5, and 6.

- Check electrical and controls.
 - Inspect motor starter and control panel.
 - Confirm all wiring connections are tight, free of abrasion and have no sharp bends in panel and on compressors.
 - Inspect contactors and relays.

-
- Verify unit wiring (low and high voltage) is correctly isolated, phased, and properly grounded.
 - Connect external 120 Vac power to power up the control panel.
 - Run the oil pump to verify pump can provide 18 to 22 psid (124.1 to 151.7 kPaD) net pressure.
 - Verify and record control parameters.
 - Verify all control interlocks are installed and properly functioning.
 - Dry run starter (non-AFD).
 - Measure condenser pressures and flow.
 - Adjust condenser flow sensing device.
 - Measure evaporator pressures and flow.
 - Adjust evaporator flow sensing device.
 - Inspect motor starter panel and perform starter panel checkout procedures.
 - Confirm proper phase check incoming power.
 - Inspect control panel.
 - Apply separate source 120 Vac power to control to perform control panel checkout procedure.
 - Review and record unit configuration parameters.
 - Confirm oil pump pressure—regulating valve setting.
 - Verify vane operator is working properly and moves without binding.
 - Dry run test starter (non-AFD).
 - Remove separate source power and reconnect wiring.

Preparation for Start-up

- Relieve nitrogen holding charge.
- Evacuate and charge the system.
- Apply power to the starter panel.
- Verify current to the oil sump heater.

Chiller Start-up

- Set Purge mode to "On."
- Bump-start the compressor and verify compressor motor rotation.
- Start chiller.
- Verify no unusual noises or vibrations and observe operating conditions.
- If necessary, adjust oil pressure regulator between 18 to 22 psid (124.1 to 151.7 kPaD) net.
- Measure and verify refrigerant pump pressure.
- When chiller is stable, take system log three times at 15-minute intervals.
- Set Purge mode to "Adaptive."
- Reset the "Starter Energy Consumption" resettable.
- Record a Chiller Service Report.
- Review "AdaptiView Display Customer Training Checklist."
 - Equipment Description
 - Stopping/Starting Chiller Operation
 - Alarms
 - Reports
 - Data Graphs
 - Equipment Settings
 - Display Settings
 - Security Settings
 - Basic Troubleshooting



CVHE, CVHF, CVHG Annual Inspection List

Follow the annual maintenance instructions provided in the text of this manual, including but not limited to:

Compressor Motor

- Motor continuity.
- Motor meg test.
- Check motor terminals.
- Inspect motor terminal board.

Starter or AFD

- Inspect starter contacts.
- Check all connections per manufacturer specifications.
- Follow all manufacturer recommendations for starter or AFD maintenance.
- Inspect/clean/service the AFD cooling system (water- or air-cooled AFD).
- Record all applicable starter or starter component settings.

Oil System

- Annual oil analysis (follow recommendations).
- Clean and lubricate oil system as required.
- Electrical inspection.
- Pump motor continuity check.
- Run oil pump and check differential oil pressure.

Condenser

- Inspect for fouling and scaling in tubes.
- Check operation of condenser water flow sensing device.
- Factory recommendation to eddy current test tubes every three years.

Evaporator

- Inspect for fouling and scaling in tubes.
- Check operation of evaporator water flow sensing device.
- Factory recommendation to eddy current test tubes every three years.

Control Circuits

- Verify control parameters.
- Test appropriate sensors for accuracy.
- Ensure sensors are properly seated in wells with thermopaste installed.
- Check evaporator leaving water temperature low temperature cutout setpoint.
- Condenser high pressure switch check-out.
- Check adjustment and operation of the inlet guide vane actuator.

Leak Test Chiller

- Check purge times and unit performance logs. If warranted, pressure leak test.
- Review oil analysis. If required, submit refrigerant sample for analysis.
- Inspect unit for any signs of refrigerant or oil leakage.
- Check unit for any loose bolts on flange, volutes, or casing.

Purge Unit

- Review the purge *Installation, Operation, and Maintenance* manual and follow maintenance and/or inspection items identified.
- Review purge pump out data.
- Review overall operation of purge and service as necessary.

Exterior

- Inlet guide vane linkage.
- Clean and touch-up painted surfaces as needed.
- Repair deteriorated, torn, or missing insulation.



Optional Accessories

- If applicable, lubricate factory-installed gantries.
- After the first month of operation, inspect Heresite[®] or Belzona[®] coated waterboxes after first month; thereafter, inspect as needed.
- Inspect anodes.
- Inspect and lubricate hinged waterboxes.
- With water flow sensing option, bleed tubing from waterboxes to transformers.



Operator Log

Water-Cooled CVHE, CVHF, CVHG CenTraVac Chiller with UC800 Controller			
Tracer AdaptiView Reports—Log Sheet	Log 1	Log 2	Log 3
Evaporator			
Entering			
Leaving			
Saturated			
Refrig. Press			
Approach			
Flow Sw Status			
Condenser			
Entering			
Leaving			
Saturated			
Refrig. Press			
Approach			
Flow Sw Status			
Compressor			
Starts			
Running Time			
Oil Tank Press			
Oil Discharge Press			
Oil Diff Press			
Oil Tank Temp			
IGV Position %			
IGV Steps			
Motor			
% RLA L1, L2, L3			
Amps L1, L2, L3			
Volts AB, BC, CA			
Power KW			
Load PF			
Winding #1 Temp			
Winding #2 Temp			
Winding #3 Temp			
with AFD only			
AFD Freq			
AFD Speed			
AFD Transistor Temp			
Purge			
Time Until Next Purge Run			
Daily Pumpout—24 hrs			
Avg. Daily Pumpout—7 days			
Daily Pumpout Limit/Alarm			
Chiller On—7 days			
Pumpout Chiller On—7 days			
Pumpout Chiller Off—7 days			
Pumpout—Life			
Purge Rfgt Cprsr Suction Temp.			
Purge Liquid Temp.			
Carbon Tank Temp.			

Date: _____
Technician: _____
Owner: _____



Trane optimizes the performance of homes and buildings around the world. A business of Ingersoll Rand, the leader in creating and sustaining safe, comfortable and energy efficient environments, Trane offers a broad portfolio of advanced controls and HVAC systems, comprehensive building services, and parts. For more information, visit www.Trane.com.

Trane has a policy of continuous product and product data improvement and reserves the right to change design and specifications without notice.