



Installation, Operation, and Maintenance

Series R[®] Air-Cooled Helical Rotary Liquid Chillers



⚠ SAFETY WARNING

Only qualified personnel should install and service the equipment. The installation, starting up, and servicing of heating, ventilating, and air-conditioning equipment can be hazardous and requires specific knowledge and training. Improperly installed, adjusted or altered equipment by an unqualified person could result in death or serious injury. When working on the equipment, observe all precautions in the literature and on the tags, stickers, and labels that are attached to the equipment.



Introduction

Read this manual thoroughly before operating or servicing this unit.

Warnings, Cautions, and Notices

Safety advisories appear throughout this manual as required. Your personal safety and the proper operation of this machine depend upon the strict observance of these precautions.

The three types of advisories are defined as follows:

⚠ WARNING Indicates a potentially hazardous situation which, if not avoided, could result in death or serious injury.

⚠ CAUTION Indicates a potentially hazardous situation which, if not avoided, could result in minor or moderate injury. It could also be used to alert against unsafe practices.

NOTICE Indicates a situation that could result in equipment or property-damage only accidents.

Important Environmental Concerns

Scientific research has shown that certain man-made chemicals can affect the earth's naturally occurring stratospheric ozone layer when released to the atmosphere. In particular, several of the identified chemicals that may affect the ozone layer are refrigerants that contain Chlorine, Fluorine and Carbon (CFCs) and those containing Hydrogen, Chlorine, Fluorine and Carbon (HCFCs). Not all refrigerants containing these compounds have the same potential impact to the environment. Trane advocates the responsible handling of all refrigerants-including industry replacements for CFCs such as HCFCs and HFCs.

Important Responsible Refrigerant Practices

Trane believes that responsible refrigerant practices are important to the environment, our customers, and the air conditioning industry. All technicians who handle refrigerants must be certified. The Federal Clean Air Act (Section 608) sets forth the requirements for handling, reclaiming, recovering and recycling of certain refrigerants and the equipment that is used in these service procedures. In addition, some states or municipalities may have additional requirements that must also be adhered to for responsible management of refrigerants. Know the applicable laws and follow them.

⚠ WARNING

Proper Field Wiring and Grounding Required!

Failure to follow code could result in death or serious injury. All field wiring **MUST** be performed by qualified personnel. Improperly installed and grounded field wiring poses **FIRE** and **ELECTROCUTION** hazards. To avoid these hazards, you **MUST** follow requirements for field wiring installation and grounding as described in NEC and your local/state electrical codes.

⚠ WARNING

Personal Protective Equipment (PPE) Required!

Installing/servicing this unit could result in exposure to electrical, mechanical and chemical hazards.

- Before installing/servicing this unit, technicians **MUST** put on all PPE required for the work being undertaken (Examples; cut resistant gloves/sleeves, butyl gloves, safety glasses, hard hat/bump cap, fall protection, electrical PPE and arc flash clothing). **ALWAYS** refer to appropriate Material Safety Data Sheets (MSDS)/Safety Data Sheets (SDS) and OSHA guidelines for proper PPE.
- When working with or around hazardous chemicals, **ALWAYS** refer to the appropriate MSDS/SDS and OSHA/GHS (Global Harmonized System of Classification and Labelling of Chemicals) guidelines for information on allowable personal exposure levels, proper respiratory protection and handling instructions.
- If there is a risk of energized electrical contact, arc, or flash, technicians **MUST** put on all PPE in accordance with OSHA, NFPA 70E, or other country-specific requirements for arc flash protection, **PRIOR** to servicing the unit. **NEVER PERFORM ANY SWITCHING, DISCONNECTING, OR VOLTAGE TESTING WITHOUT PROPER ELECTRICAL PPE AND ARC FLASH CLOTHING. ENSURE ELECTRICAL METERS AND EQUIPMENT ARE PROPERLY RATED FOR INTENDED VOLTAGE.**

Failure to follow instructions could result in death or serious injury.

Factory Warranty Information

Compliance with the following is required to preserve the factory warranty:

All Unit Installations

Startup **MUST** be performed by Trane, or an authorized agent of Trane, to **VALIDATE** this WARRANTY. Contractor must provide a two-week startup notification to Trane (or an agent of Trane specifically authorized to perform startup).

Copyright

This document and the information in it are the property of Trane, and may not be used or reproduced in whole or in part without written permission. Trane reserves the right to revise this publication at any time, and to make changes to its content without obligation to notify any person of such revision or change.

Trademarks

All trademarks referenced in this document are the trademarks of their respective owners.

Revision History

RTAC-SVX01M-EN (30 Jan 2015)

- Correction to Model Number digit 5-7.
- Addition of seismic isolator option.
- Removal of duplicated information found in other locations (nameplate, catalog, submittal).
- Removal of detailed communication system information found in controls documents.



Table of Contents

Introduction	2	Isolator Selection and Mounting	
Table of Contents	4	Locations	37
Model Number Description	6	Drainage	47
Outdoor Unit Nameplate	6	Evaporator Water Piping	47
Compressor Nameplate	6	Entering Chilled Water Piping	48
Unit Model Number	7	Leaving Chilled Water Piping	48
Compressor Model Number	8	Evaporator Drain	48
Compressor Serial Number	8	Evaporator Flow Switch	48
General Data	9	Water Pressure Gauges	52
Unit Description	9	Water Pressure Relief Valves	52
Accessory/Option Information	9	Freeze Avoidance	53
Isolator Shipping Location	9	Low Evaporator Refrigerant Cutout, Glycol	
Pre-installation	20	Recommendations	54
Unit Inspection	20	Procedure	54
Inspection Checklist	20	Specials	54
Storage	20	Installation - Mechanical	
Installation Responsibilities	20	Remote Evaporator Option	56
General	20	System Configuration and Interconnecting	
Dimensions and Weights	21	Refrigerant Piping	56
Dimensions	21	Line Sizing	60
Clearances	21	Liquid Line Sizing Steps	60
Weights	24	Suction Line Sizing Steps	61
Non-Seismically Rated Units	24	Suction Accumulator Sizing	61
Seismically Rated Unit Weights	26	Piping Installation Procedures	62
Remote Evaporator Unit Weights	27	Refrigerant Sensors	62
Installation - Mechanical	28	Refrigerant Pressure Relief Valve Venting	62
Location Requirements	28	Leak Test and Evacuation	63
Noise Considerations	28	Refrigerant and Additional Oil Charge	64
Foundation	28	Refrigerant Charge Determination	64
Clearances	28	Oil Charge Determination	64
Rigging	28	Installation - Electrical	65
Lifting Procedure	28	General Recommendations	65
Isolation and Sound Emission	34	Installer-Supplied Components	66
Mounting and Leveling	34	Power Supply Wiring	66
Unit Isolation	34	Control Power Supply	67
Elastomeric Isolators		Heater Power Supply and Convenience	
(Optional for units without seismic rating)	34	Outlet (Packaged Units Only)	67
Unit Isolation for Seismically Rated Units	35	Interconnecting Wiring	68
		Chilled Water Pump Control	68
		Alarm and Status Relay Outputs	

(Programmable Relays)	68	TechView	83
Relay Assignments Using TechView	69	Unit View	85
Low Voltage Wiring	69	Compressor Service View	85
Emergency Stop	69	Status View	85
External Auto/Stop	70	Setpoint View	85
External Circuit Lockout – Circuit #1 and #2 70		Diagnostics View	86
Ice Building Option	70	Configuration View	86
External Chilled Water Setpoint (ECWS) Option	70	Software View	89
External Current Limit Setpoint (ECLS) Option	71	Binding View	89
Chilled Water Reset (CWR)	71	Replacing or Adding Devices	89
Communications Interface Options	72	Pre-Start Checkout	92
Tracer Communications Interface Option	72	Start-Up and Shutdown	93
LonTalk™ Interface (LCI-C)	72	Unit Start-Up	93
Operating Principles	73	Temporary Shutdown and Restart	94
Refrigeration Cycle	73	Extended Shutdown Procedure	94
Refrigerant R-134a	73	Seasonal Unit Start-Up Procedure	95
Compressor	73	System Restart After Extended Shutdown	95
Condenser and Subcooler	74	Sequence of Operation	96
Expansion Valve	74	Maintenance	100
Evaporator	74	Weekly	100
Oil System	74	Monthly	100
Controls Interface	75	Annual	100
Overview	75	Refrigerant and Oil Charge Management	100
Controls Interface	75	Lubrication System	101
DynaView Display	75	Oil Sump Level Check	101
Key Functions	75	Condenser Maintenance	101
Display Screens	76	Condenser Coil Cleaning	101
Modes Screen	77	Travel Restraint	102
Chiller Screen	81	Diagnostics	103
Compressor Screen	81	Legend to Diagnostics Table	103
Refrigerant Screen	81	Starter Diagnostics	103
Setpoint Screen	82	Main Processor Diagnostics	108
Diagnostic Screen	83	Communication Diagnostics	116
Power-Up	83	Main Processor Boot Messages and Diagnostics	121
Display Formats	83	Unit Wiring	122
Units	83	Log and Check Sheet	124
Languages	83		



Model Number Description

Nameplates

The RTAC outdoor unit nameplates are applied to the exterior of the Control Panel. A compressor nameplate is located on each compressor. When the unit arrives, if unit is not covered with a tarp, compare all nameplate data with ordering, submittal, and shipping information.

Outdoor Unit Nameplate

See [Figure 1, p. 6](#) for a typical unit nameplate. The outdoor unit nameplate provides the following information:

- Unit model and size description.
- Unit serial number.
- Identifies unit electrical requirements.
- Lists correct operating charges of R-134a and refrigerant oil (Trane OIL00048).
- Lists unit test pressures.
- Identifies installation, operation and maintenance and service data literature (Pueblo).
- Lists drawing numbers for unit wiring diagrams (Pueblo).

Model Number Coding System

The model numbers for the unit and the compressor are composed of numbers and letters that represent features of the equipment. Shown in the following table is a sample

of typical unit model number and the coding system for each.

Each position, or group of positions, in the model number is used to represent a feature. For example, in the first table, position 08 of the unit model number, Unit Voltage, contains the number "4". A 4 in this position means that the unit voltage is 460/60/3.

Unit Model Number. An example of a typical unit model number (M/N) is:

RTAC 350A UA0N NAFN N1NX 1TEN NN0N N01N

Model number digits are selected and assigned in accordance with the definitions as listed in "[Unit Model Number,](#)" p. 7.

Compressor Nameplate

The compressor nameplate provides following information:

- Compressor model number. See "[Compressor Model Number,](#)" p. 8.
- Compressor serial number. See "[Compressor Serial Number,](#)" p. 8.
- Compressor electrical characteristics.
- Utilization range.
- Recommended refrigerant.

Figure 1. Typical unit nameplate



Model Number Descriptions

Unit Model Number

Digits 1, 2 - Unit Model

RT = Rotary chiller

Digit 3 - Unit Type

A = Air-cooled

Digit 4 - Development Sequence

C = Development sequence

Digits 5, 6 & 7 - Nominal Capacity

120 = 120 Nominal tons
130 = 130 Nominal tons
140 = 140 Nominal tons
155 = 155 Nominal tons
170 = 170 Nominal tons
185 = 185 Nominal tons
200 = 200 Nominal tons
225 = 225 Nominal tons
250 = 250 Nominal tons
275 = 275 Nominal tons
300 = 300 Nominal tons
350 = 350 Nominal tons
375 = 375 Nominal tons
400 = 400 Nominal tons
450 = 450 Nominal tons
500 = 500 Nominal tons

Digit 8 - Unit Voltage

A = 200/60/3
C = 230/60/3
J = 380/60/3
D = 400/50/3
4 = 460/60/3
5 = 575/60/3

Digit 9 - Manufacturing Location

U = Water Chiller Business Unit, Pueblo, CO USA

Digits 10, 11 - Design Sequence

XX = Factory Input

Digit 12 - Unit Basic Configuration

N = Standard efficiency/performance
H = High efficiency/performance
A = Extra efficiency/performance

Digit 13 - Agency Listing

N = No agency listing
U = C/UL listing
S = Seismic rated - IBC and OSHPD
R = C/UL listed and seismic rated

Digit 14 - Pressure Vessel Code

A = ASME pressure vessel code
C = Canadian code
D = Australian code
L = Chinese code

Digit 15 - Evaporator Application

F = Standard (40-60 F) leaving temp
G = Low (Less than 40 F) leaving temp
R = Remote (40-60 F) leaving temp

Digit 16 - Evaporator Configuration

N = 2 pass, 0.75" insulation
P = 3 pass, 0.75" insulation
Q = 2 pass, 1.25" insulation
R = 3 pass, 1.25" insulation

Digit 17 - Condenser Application

N = Standard ambient (25-115°F)
H = High ambient (25-125°F)
L = Low ambient (0-115°F)
W = Wide ambient (0-125°F)

Digit 18 - Condenser Fin Material

1 = Standard aluminum slit fins
2 = Copper fins
4 = CompleteCoat™ epoxy coated fins

Digit 19 - Condenser Fan/Motor Configuration

T = STD fans with TEAO motors
W = Low noise fans

Digit 20 - Compressor Motor Starter Type

X = Across-the-line
Y = Wye-delta closed transition

Digit 21 - Incoming Power Line Connection

1 = Single point power connection
2 = Dual point power connection

Digit 22 - Power Line Connection Type

T = Terminal block connection
D = Non-fused disconnect switch(es)
C = Circuit breaker(s)

Digit 23 - Unit Operator Interface

D = DynaView operator interface

Digit 24 - Remote Operator Interface

N = No remote interface
C = Tracer™ Comm 3 interface
B = BACnet® interface
L = LonTalk® compatible (LCI-C) interface

Digit 25 - Control Input Accessories/Options

N = No remote inputs
R = Ext. evaporator leaving water setpoint
C = Ext. current limit setpoint
B = Ext. leaving water and current limit setpoint

Digit 26 - Control Output Accessories/Options

N = No output options
A = Alarm relay outputs
C = Ice making I/O
D = Alarm relay outputs and ice making I/O

Digit 27 - Electrical Protection Options

0 = No short circuit rating
5 = Default short circuit rating
6 = High amp short circuit rating

Digit 28 - Flow Switch

T = Factory installed flow switch - water
U = Factory installed flow switch glycol

Digit 29 - Control Panel Accessories

N = No convenience outlet
A = 15A 115V convenience outlet (60Hz)

Digit 30 - Service Valves

1 = With suction service valves

Digit 31 - Compressor Sound Attenuation Option

0 = No compressor sound attenuation
1 = Factory installed compressor sound attenuation

Digit 32 - Appearance Options

N = No appearance options
A = Architectural louvered panels
C = Half louvers

Digit 33 - Installation Accessories

N = No installation accessories
F = Flange kit for water connections
R = Neoprene in shear unit isolators
G = Neoprene isolators and flange kit
E = Seismic elastomeric isolation pads
S = Seismic spring isolators



Model Number Descriptions

Digit 34 - Factory Testing Options

- 0 = Standard functional test
- C = Customer-witnessed performance test with report
- C = Customer-witnessed performance test plus Rapid Restart test
- E = Non-witnessed performance test with report

Digit 35 – Control, Label & Literature

- C = Spanish
- E = English
- F = French

Digit 36 – Special Order

- X = Standard unit configuration
- S = Unit has special order feature

Digit 37 – Safety Devices

- N = Standard

Compressor Model Number

Digits 1-3 – Compressor Family

CHH= Positive displacement, refrigerant, helical rotary, hermetic compressor

Digit 4– Compressor Type

- T = GP2+

Digit 5

- 0 = All compressors

Digit 6 – Frame Size

- K = K Frame
- L = L Frame
- M = M Frame
- N = N Frame

Digit 7 – Compressor Capacity

- 3 = GP2+ Smaller capacity (minor)
- 4 = GP2+ Larger capacity (major)

Compressor Serial Number

Digits 1-2 – Year

YY = Last two digits of year of manufacture

Digits 3-4 – Week

WW= Week of build, from 00 to 52

Digit 5 – Day

- 1 = Monday
- 2 = Tuesday
- 3 = Wednesday
- 4 = Thursday
- 5 = Friday
- 6 = Saturday
- 7 = Sunday

Digits 6-8 – Coded Time Stamp

TTT= Used to ensure uniqueness of serial number

Digit 9 – Assembly Line

- L = Varies with facility

Digit 10– Build Location

- A = Monterrey



General Data

Unit Description

The 140 - 500 ton Model RTAC units are helical-rotary type, air-cooled liquid chillers designed for installation outdoors. The compressor circuits are completely assembled, hermetic packages that are factory-piped, wired, leak-tested, dehydrated, and tested for proper control operation before shipment.

Chilled water inlet and outlet openings are covered for shipment. Each compressor has a separate compressor motor starter. The RTAC series features Trane's exclusive Adaptive Control™ logic, which monitors the control variables that govern the operation of the chiller unit. Adaptive Control logic can adjust capacity variables to avoid chiller shutdown when necessary, and keep producing chilled water. The units feature two independent refrigerant circuits. Compressor unloaders are solenoid actuated and oil pressure operated. Each refrigerant circuit is provided with filter, sight glass, electronic expansion valve, and charging valves. The shell-and-tube type evaporator is manufactured in accordance with ASME standards or other international codes. Each evaporator is fully insulated and is equipped with water drain and vent connections. Packaged units have heat tape protection to - 20°F (-28.9°C) as standard. As an option, a convenience outlet can be supplied.

Note: Packaged units are factory charged with refrigerant and oil.

Figure 2. Typical RTAC packaged unit and components



Accessory/Option Information

Check all the accessories and loose parts which are shipped with the unit against the shipping list. Included in these items will be water vessel drain plugs, rigging and electrical diagrams, and service literature, which are placed inside the control panel and/or starter panel for shipment.

Isolator Shipping Location

If optional neoprene isolators (model number digit 33) are ordered with unit, they are shipped mounted on the unit. See Figure 3 and Figure 4.

Figure 3. Isolator shipping locations 140-250T units

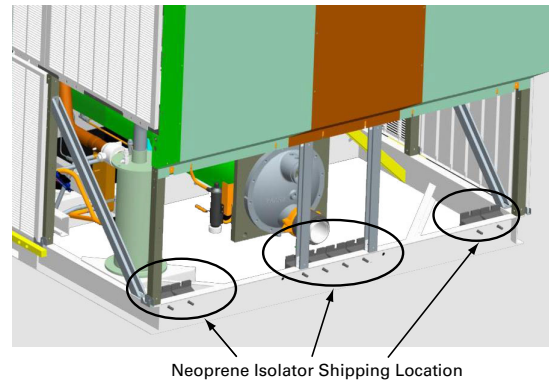
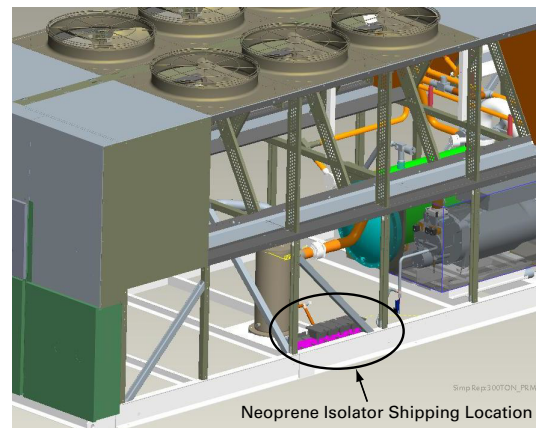

Figure 4. Isolator shipping locations 275-500T units





General Data

Table 1. General Data - 60 hz units - standard efficiency - IP

Size		140	155	170	185	200	225	250	275	300	350	400	450	500
Compressor		Screw												
Quantity	#	2	2	2	2	2	2	2	3	3	3	4	4	4
Nominal size @60Hz	(tons)	70/70	85/70	85/85	100/85	100/100	120/100	120/120	85-85/100	100-100/100	120-120/100	100-100/100-100	120-120/100-100	120-120/120-120
Evaporator		Flooded												
Water storage	(gal)	29	32	34	36	40	39	43	62	67	72	83	86	91
2 pass arrangement														
Min flow	(gpm)	193	214	202	217	241	217	241	309	339	375	404	422	461
Max flow	(gpm)	709	785	741	796	883	796	883	1134	1243	1374	1483	1548	1690
Water conn	(NPS-in)	4	4	6	6	6	6	6	8	8	8	8	8	8
3 pass arrangement														
Min flow	(gpm)	129	143	135	145	161	145	161	206	226	250	270	282	307
Max flow	(gpm)	473	523	494	531	589	531	589	756	829	916	989	1032	1127
Water conn	(NPS-in)	3.5	3.5	4	4	4	4	4	6	6	6	8	8	8
Condenser		Fin and tube												
Qty of coils	#	4	4	4	4	4	4	4	8	8	8	8	8	8
Coil length	(in)	156/156	180/156	180/180	216/180	216/216	252/216	252/252	180/108	216/108	252/108	216/216	252/216	252/252
Coil height	(in)	42	42	42	42	42	42	42	42	42	42	42	42	42
	(mm)	1067	1067	1067	1067	1067	1067	1067	1067	1067	1067	1067	1067	1067
# of rows	#	3	3	3	3	3	3	3	3	3	3	3	3	3
Fins per foot	(fpf)	192	192	192	192	192	192	192	192	192	192	192	192	192
Fan		Direct drive propeller												
Quantity	#	4/4	5/4	5/5	6/5	6/6	7/6	7/7	10/6	12/6	14/6	12/12	14/12	14/14
Diameter	(in)	30.0	30.0	30.0	30.0	30.0	30.0	30.0	30.0	30.0	30.0	30.0	30.0	30.0
Air flow per fan	(cfm)	9625	9394	9209	9209	9209	9210	9210	9209	9209	9208	9209	9210	9214
Power/motor	(hp)	1.5	1.5	1.5	1.5	1.5	1.5	1.5	1.5	1.5	1.5	1.5	1.5	1.5
Fan speed	(rpm)	1140	1140	1140	1140	1140	1140	1140	1140	1140	1140	1140	1140	1140
Tip speed	(Ft/min)	8954	8954	8954	8954	8954	8954	8954	8954	8954	8954	8954	8954	8954
General Unit		HFC-134a												
# Refrig ckts	#	2	2	2	2	2	2	2	2	2	2	2	2	2
% min load	%	15	15	15	15	15	15	15	15	15	15	15	15	15
Refrigerant charge	(lb)	165/165	175/165	175/175	215/210	215/215	225/215	225/225	365/200	415/200	460/200	415/415	460/415	460/460
Oil charge	(gal)	1.3/1.3	1.3/1.3	1.3/1.3	1.9/1.3	1.9/1.9	1.9/1.9	1.9/1.9	4.2/1.9	4.6/2.9	4.6/1.9	4.6/4.6	4.6/4.6	4.6/4.6
Min ambient-std	(°F)	25	25	25	25	25	25	25	25	25	25	25	25	25
Min ambient-low	(°F)	0	0	0	0	0	0	0	0	0	0	0	0	0

1. Data containing information on two circuits is shown as follows: ckt 1/ ckt 2.
2. Minimum start-up/operating ambient is based on a 5 mph wind across the condenser.
3. RTAC units must only operate with refrigerant R-134a and Trane Oil 00048.

Table 2. General Data - 60 hz units - high efficiency - IP

Size		140	155	170	185	200	225	250	275	300	350	400
Compressor		Screw										
Quantity	#	2	2	2	2	2	2	2	3	3	4	4
Nominal size @60Hz	(tons)	70/70	85/70	85/85	100/85	100/100	120/100	120/120	85-85/100	100-100/100	85-85/85/85	100-100/100-100
Evaporator		Flooded										
Water storage	(gal)	34	36	40	39	43	43	43	72	72	83	91
2 pass arrangement												
Min flow	(gpm)	202	217	241	217	241	241	241	375	375	404	461
Max flow	(gpm)	741	796	883	796	883	883	883	1374	1374	1483	1690
Water conn	(NPS-in)	6	6	6	6	6	6	6	8	8	8	8
3 pass arrangement												
Min flow	(gpm)	135	145	161	145	161	161	161	250	250	270	307
Max flow	(gpm)	494	531	589	531	589	589	589	916	916	989	1127
Water conn	(NPS-in)	4	4	4	4	4	4	4	6	6	8	8
Condenser		Fin and tube										
Qty of coils	#	4	4	4	4	4	8	8	8	8	8	8
Coil length	(in)	180/180	216/180	216/216	252/216	252/252	144/144	144/144	216/144	252/144	216/216	252/252
Coil height	(in)	42	42	42	42	42	42	42	42	42	42	42
Number of rows	#	3	3	3	3	3	3	3	3	3	3	3
Fins per foot	(fpf)	192	192	192	192	192	192	192	192	192	192	192
Fan		Direct drive propeller										
Quantity	#	5/5	6/5	6/6	7/6	7/7	8/6	8/8	12/6	14/6	12/12	14/14
Diameter	(in)	30	30	30	30	30	30	30	30	30	30	30
Air flow/fan	(cfm)	9199	9199	9199	9200	9201	9783	9203	9652	9605	9199	9201
Power/motor	(hp)	1.5	1.5	1.5	1.5	1.5	1.5	1.5	1.5	1.5	1.5	1.5
Fan speed	(rpm)	1140	1140	1140	1140	1140	1140	1140	1140	1140	1140	1140
Tip speed	(Ft/Min)	8954	8954	8954	8954	8954	8954	8954	8954	8954	8954	8954
General unit		HFC-134a										
# Refrig ckts	#	2	2	2	2	2	2	2	2	2	2	2
% min load	%	15	15	15	15	15	15	15	15	15	15	15
Refrigerant charge	(lb)	175/175	215/205	215/215	225/215	225/225	235/235	235/235	415/200	460/200	415/415	460/460
Oil charge	(gal)	1.3/1.3	1.3/1.3	1.3/1.3	1.9/1.3	1.9/1.9	1.9/1.9	1.9/1.9	2.1-2.1/1.9	2.3-2.3/1.9	2.1-2.1/2.1-2.1	2.3-2.3/2.3-2.3
Min ambient-std	(°F)	25	25	25	25	25	25	25	25	25	25	25
Min ambient-low	(°F)	0	0	0	0	0	0	0	0	0	0	0

1. Data containing information on two circuits is shown as follows: ckt 1/ ckt 2.
2. Minimum start-up/operating ambient is based on a 5 mph wind across the condenser.
3. RTAC units must only operate with refrigerant R-134a and Trane Oil 00048.



General Data

Table 3. General Data - 60 hz units - extra efficiency - IP

Size		140	155	170	185	200	250	275	300	350
Compressor		Screw								
Quantity	#	2	2	2	2	2	3	3	4	4
Nominal size @60Hz	(tons)	70/70	85/70	85/85	100/85	100/100	70-70/85	85-85/85	70-70/70-70	85-85/85-85
Evaporator		Flooded								
Water storage	(gal)	40	39	43	43	43	72	72	83	91
2 pass arrangement										
Min flow	(gpm)	241	217	241	241	241	375	375	404	461
Max flow	(gpm)	883	796	883	883	883	1374	1374	1483	1690
Water conn	(NPS-in)	6	6	6	6	6	8	8	8	8
3 pass arrangement										
Min flow	(gpm)	161	145	161	161	161	250	250	270	307
Max flow	(gpm)	589	531	589	589	589	916	916	989	1127
Water conn	(NPS-in)	4	4	4	4	4	6	6	8	8
Condenser		Fin and tube								
Qty of coils	#	4	4	4	8	8	8	8	8	8
Coil length	(in)	216/216	252/216	252/252	144/144	144/144	216/144	252/144	216/216	252/252
Coil height	(in)	42	42	42	42	42	42	42	42	42
Number of rows	#	3	3	3	3	3	3	3	3	3
Fins per foot	(fpf)	192	192	192	192	192	192	192	192	192
Fan		Direct drive propeller								
Quantity	#	6/6	7/6	7/7	8/6	8/8	12/6	14/6	12/12	14/14
Diameter	(in)	30	30	30	30	30	30	30	30	30
Air flow/fan	(cfm)	9199	9200	9201	9783	9203	9652	9605	9199	9201
Power/motor	(hp)	1.5	1.5	1.5	1.5	1.5	1.5	1.5	1.5	1.5
Fan speed	(rpm)	1140	1140	1140	1140	1140	1140	1140	1140	1140
Tip speed	(Ft/Min)	8954	8954	8954	8954	8954	8954	8954	8954	8954
General unit		HFC-134a								
# Refrig ckts	#	2	2	2	2	2	2	2	2	2
% min load	%	15	15	15	15	15	15	15	15	15
Refrigerant charge	(lb)	215/215	225/215	225/225	235/235	235/235	415/200	460/200	415/415	460/460
Oil charge	(gal)	1.3/1.3	1.9/1.3	1.9/1.9	1.9/1.9	1.9/1.9	2.1-2.1/1.9	2.1-2.1/1.9	2.1-2.1/2.1-2.1	2.1-2.1/2.1-2.1
Min ambient-std	(°F)	25	25	25	25	25	25	25	25	25
Min ambient-low	(°F)	0	0	0	0	0	0	0	0	0

1. Data containing information on two circuits is shown as follows: ckt 1/ ckt 2.
2. Minimum start-up/operating ambient is based on a 5 mph wind across the condenser.
3. RTAC units must only operate with refrigerant R-134a and Trane Oil 00048.

Table 4. General Data - 60 hz units - standard efficiency - SI

Size		140	155	170	185	200	225	250	275	300	350	400	450	500
Compressor		Screw												
Quantity	#	2	2	2	2	2	2	2	3	3	3	4	4	4
Nominal size (tons) @60Hz		70/70	85/70	85/85	100/85	100/100	120/100	120/120	85-85/100	100-100/100	120-120/100	100-100/100-100	120-120/100-100	120-120/120-120
Evaporator		Flooded												
Water storage	(L)	110.0	121	129	136	151	148	163	235	254	273	314	326	344
2 pass arrangement														
Min flow	(L/s)	12	14	13	14	15	14	15	19	21	24	25	27	29
Max flow	(L/s)	45	50	47	50	56	50	56	72	78	87	94	98	107
Water conn	(NPS-in)	4	4	6	6	6	6	6	8	8	8	8	8	8
3 pass arrangement														
Min flow	(L/s)	8	9	9	9	10	9	10	13	14	16	17	18	19
Max flow	(L/s)	30	33	31	34	37	34	37	48	52	58	62	65	71
Water conn	(NPS-in)	3.5	3.5	4	4	4	4	4	6	6	6	8	8	8
Condenser		Fin and tube												
Qty of coils	#	4	4	4	4	4	4	4	8	8	8	8	8	8
Coil length	(mm)	3962/3962	4572/3962	4572/4572	5486/4572	5486/5486	6400/5486	6400/6400	4572/2743	5486/2743	6400/2743	5486/5486	6400/5486	6400/6400
Coil height	(mm)	1067	1067	1067	1067	1067	1067	1067	1067	1067	1067	1067	1067	1067
# of rows	#	3	3	3	3	3	3	3	3	3	3	3	3	3
Fins per foot	(fpf)	192	192	192	192	192	192	192	192	192	192	192	192	192
Fan		Direct drive propeller												
Quantity	#	4/4	5/4	5/5	6/5	6/6	7/6	7/7	10/6	12/6	14/6	12/12	14/12	14/14
Diameter	(mm)	726.0	726.0	726.0	726.0	726.0	726.0	726.0	726.0	726.0	726.0	726.0	726.0	726.0
Air flow per fan	(m ³ /hr)	16351	15958	15644	15644	15644	15646	15647	15644	15645	15642	15645	15646	15653
Power/motor	(kW)	1.12	1.12	1.12	1.12	1.12	1.12	1.12	1.12	1.12	1.12	1.12	1.12	1.12
Fan speed	(rps)	19	19	19	19	19	19	19	19	19	19	19	19	19
Tip speed	M/S	45	45	45	45	45	45	45	45	45	45	45	45	45
General Unit		HFC-134a												
# Refrig ckts	#	2	2	2	2	2	2	2	2	2	2	2	2	2
% min load	%	15	15	15	15	15	15	15	15	15	15	15	15	15
Refrigerant charge	(kg)	75/75	79/75	79/79	98/95	98/98	102/98	102/102	166/91	188/91	209/91	188/188	209/188	209/209
Oil charge	(L)	5/5	5/5	5/5	7/5	7/7	7/7	7/7	8-8/7	9-9/11	9-9/11	9-9/9-9	9-9/9-9	9-9/9-9
Min ambient-std	(°C)	-3.9	-3.9	-3.9	-3.9	-3.9	-3.9	-3.9	-3.9	-3.9	-3.9	-3.9	-3.9	-3.9
Min ambient-low	(°C)	-17.8	-17.8	-17.8	-17.8	-17.8	-17.8	-17.8	-17.8	-17.8	-17.8	-17.8	-17.8	-17.8

1. Data containing information on two circuits is shown as follows: ckt 1/ ckt 2.
2. Minimum start-up/operating ambient is based on a 5 mph wind across the condenser.
3. RTAC units must only operate with refrigerant R-134a and Trane Oil 00048.



General Data

Table 5. General Data - 60 hz units - high efficiency - SI

Size		140	155	170	185	200	225	250	275	300	350	400
Compressor		Screw										
Quantity	#	2	2	2	2	2	2	2	4	4	4	4
Nominal size @60Hz	(tons)	70/70	85/70	85/85	100/85	100/100	70-70/85	85-85/85	70-70/70-70	85-85/85-85	85-85/85/85	100-100/100-100
Evaporator		Flooded										
Water storage	(L)	129	136	151	148	163	163	163	273	273	314	344
2 Pass arrangement												
Min flow	(L/s)	13	14	15	14	15	15	15	24	24	25	29
Max flow	(L/s)	47	50	56	50	56	56	56	87	87	94	107
Water conn	(NPS-in)	6	6	6	6	6	6	6	8	8	8	8
3 Pass arrangement												
Min flow	(L/s)	9	9	10	9	10	10	10	16	16	17	19
Max flow	(L/s)	31	34	37	34	37	37	37	58	58	62	71
Water conn	(NPS-in)	4	4	4	4	4	4	4	6	6	8	8
Condenser		Fin and tube										
Qty of coils	#	4	4	4	4	4	8	8	8	8	8	8
Coil length	(mm)	4572/4572	5486/4572	5486/5486	6400/5486	6400/6400	3657/3657	3657/3657	5486/3657	6400/3657	5486/5486	6400/6400
Coil height	(mm)	1067	1067	1067	1067	1067	1067	1067	1067	1067	1067	1067
Number of rows	#	3	3	3	3	3	3	3	3	3	3	3
Fins per foot	(fpf)	192	192	192	192	192	192	192	192	192	192	192
Fan		Direct drive propeller										
Quantity	#	5/5	6/5	6/6	7/6	7/7	8/6	8/8	12/6	14/6	12/12	14/14
Diameter	(mm)	762	762	762	762	762	762	762	762	762	762	762
Air per fan	(m ³ /hr)	15628	15628	15628	15629	15631	16619	15634	16397	16317	15628	15631
Power/motor	(kW)	1.12	1.12	1.12	1.12	1.12	1.12	1.12	1.12	1.12	1.12	1.12
Fan speed	(rps)	19	19	19	19	19	19	19	19	19	19	19
Tip speed	M/S	45	45	45	45	45	45	45	45	45	45	45
General unit		HFC-134a										
# refrig ckts	#	2	2	2	2	2	2	2	2	2	2	2
% min load	%	15	15	15	15	15	15	15	15	15	15	15
Refrig charge	(kg)	79/79	98/93	98/98	102/98	102/102	107/107	107/107	188/91	209/91	188/188	209/209
Oil charge	(L)	5/5	5/5	5/5	7/5	7/7	7/7	7/7	8-8/7	9-9/7	8-8/8-8	9-9/9-9
Min ambient-std	(°C)	-3.9	-3.9	-3.9	-3.9	-3.9	-3.9	-3.9	-3.9	-3.9	-3.9	-3.9
Min ambient-low	(°C)	-17.8	-17.8	-17.8	-17.8	-17.8	-17.8	-17.8	-17.8	-17.8	-17.8	-17.8

1. Data containing information on two circuits is shown as follows: ckt 1/ ckt 2.
2. Minimum start-up/operating ambient is based on a 5 mph wind across the condenser.
3. RTAC units must only operate with refrigerant R-134a and Trane Oil 00048.

Table 6. General Data - 60 hz units - extra efficiency - SI

Size		140	155	170	185	200	250	275	300	350
Compressor										
Quantity	#	2	2	2	2	2	3	3	4	4
Nominal size @60Hz	(tons)	85/85	100/85	100/100	120/100	120/120	85-85/100	100-100/100	85-85/85/85	100-100/100-100
Evaporator										
						Flooded				
Water storage	(L)	151	148	163	163	163	273	273	314	344
2 Pass arrangement										
Min flow	(L/s)	15	14	15	15	15	24	24	25	29
Max flow	(L/s)	56	50	56	56	56	87	87	94	107
Water conn	(NPS-in)	6	6	6	6	6	8	8	8	8
3 Pass arrangement										
Min flow	(L/s)	10	9	10	10	10	16	16	17	19
Max flow	(L/s)	37	34	37	37	37	58	58	62	71
Water conn	(NPS-in)	4	4	4	4	4	6	6	8	8
Condenser										
						Fin and tube				
Qty of coils	#	4	4	4	8	8	8	8	8	8
Coil length	(mm)	5486/5486	6400/5486	6400/6400	3657/3657	4572/2743	5486/3657	6400/3657	5486/5486	6400/6400
Coil height	(mm)	1067	1067	1067	1067	1067	1067	1067	1067	1067
Number of rows	#	3	3	3	3	3	3	3	3	3
Fins per foot	(fpf)	192	192	192	192	192	192	192	192	192
Fan										
						Direct drive propeller				
Quantity	#	6/6	7/6	7/7	8/6	8/8	12/6	14/6	12/12	14/14
Diameter	(mm)	762	762	762	762	762	762	762	762	762
Air per fan	(m ³ /hr)	15628	15629	15631	16619	15634	16397	16317	15628	15631
Power/motor	(kW)	1.12	1.12	1.12	1.12	1.12	1.12	1.12	1.12	1.12
Fan speed	(rps)	19	19	19	19	19	19	19	19	19
Tip speed	M/S	45	45	45	45	45	45	45	45	45
General unit										
						HFC-134a				
# refrig ckts	#	2	2	2	2	2	2	2	2	2
% min load	%	15	15	15	15	15	15	15	15	15
Refrig charge	(kg)	98/98	102/98	102/102	107/107	107/107	188/91	209/91	188/188	209/209
Oil charge	(L)	5/5	7/5	7/7	7/7	7/7	8-8/7	8-8/7	8-8/8-8	8-8/8-8
Min ambient-std	(°C)	-3.9	-3.9	-3.9	-3.9	-3.9	-3.9	-3.9	-3.9	-3.9
Min ambient-low	(°C)	-17.8	-17.8	-17.8	-17.8	-17.8	-17.8	-17.8	-17.8	-17.8

1. Data containing information on two circuits is shown as follows: ckt 1/ ckt 2.
2. Minimum start-up/operating ambient is based on a 5 mph wind across the condenser.
3. RTAC units must only operate with refrigerant R-134a and Trane Oil 00048.



General Data

Table 7. General Data - 50 hz units - standard efficiency - IP

Size		140	155	170	185	200	250	275	300	350	375	400
Compressor		Screw										
Quantity	#	2	2	2	2	2	3	3	3	4	4	4
Nominal size@50Hz	(tons)	70/70	85/70	85/85	100/85	100/100	70-70 / 100	85-85 / 100	100-100/ 100	85-85/ 85-85	100-100/ 85-85	100-100/ 100-100
Evaporator		Flooded										
Water storage	(gal)	29	32	34	36	40	56	62	67	75	79	83
2 pass arrangement												
Min flow	(gpm)	193	214	202	217	241	265	309	339	351	381	404
Max flow	(gpm)	709	785	741	796	883	970	1134	1243	1287	1396	1483
Water conn	(NPS-in)	4	4	6	6	6	8	8	8	8	8	8
3 pass arrangement												
Min flow	(gpm)	129	143	135	145	161	176	206	226	234	254	270
Max flow	(gpm)	473	523	494	531	589	647	756	829	858	930	989
Water conn	(NPS-in)	3.5	3.5	4	4	4	6	6	6	8	8	8
Condenser		Fin and tube										
Qty of coils	#	4	4	4	4	4	8	8	8	8	8	8
Coil length	(in)	156/156	180/156	180/180	216/180	216/216	156/108	180/108	216/108	180/180	216/180	216/216
Coil height	(in)	42	42	42	42	42	42	42	42	42	42	42
Number of rows	#	3	3	3	3	3	3	3	3	3	3	3
Fins per foot	(fpf)	192	192	192	192	192	192	192	192	192	192	192
Fan		Direct drive propeller										
Quantity	#	4/4	5/4	5/5	6/5	6/5	8/6	10/6	12/6	10/10	12/10	12/12
Diameter	(in)	30	30	30	30	30	30	30	30	30	30	30
Air flow per fan	(cfm)	7918	7723	7567	7567	7567	7764	7566	7567	7567	7567	7567
Power per motor	(hp)	1.0	1.0	1.0	1.0	1.0	1.0	1.0	1.0	1.0	1.0	1.0
Fan speed	(rpm)	950	950	950	950	950	950	950	950	950	950	950
Tip speed	(Ft/min)	7461	7461	7461	7461	7461	7461	7461	7461	7461	7461	7461
General unit		HFC-134a										
# refrig ckts	#	2	2	2	2	2	2	2	2	2	2	2
% min load	%	15	15	15	15	15	15	15	15	15	15	15
Refrig charge	(lb)	175/175	215/205	215/215	225/215	225/225	235/235	235/235	415/200	460/200	415/415	460/460
Oil charge	(gal)	1.3/1.3	1.3/1.3	1.3/1.3	1.9/1.3	1.9/1.9	2.1-2.1/ 1.9	2.1-2.1/ 1.9	2.3-2.3/ 1.9	2.1-2.1/ 2.1-2.1	2.3-2.3/ 2.1-2.1	2.3-2.3/ 2.3-2.3
Min ambient-std	(°F)	25	25	25	25	25	25	25	25	25	25	25
Min ambient-low	(°F)	0	0	0	0	0	0	0	0	0	0	0

1. Data containing information on two circuits is shown as follows: ckt 1/ ckt 2.
2. Minimum start-up/operating ambient is based on a 5 mph wind across the condenser.
3. RTAC units must only operate with refrigerant R-134a and Trane Oil 00048.

Table 8. General Data - 50 hz units - high efficiency - IP

Size		120	130	140	155	170	185	200	250	275	300	350	375	400
Compressor		Screw												
Quantity	#	2	2	2	2	2	2	2	3	3	3	4	4	4
Nominal size@50Hz	(tons)	60/60	70/60	70/70	85/70	85/85	100/85	100/100	70-70 / 100	85-85 / 100	100-100/ 100	85-85 / 85-85	100-100/ 85-85	100-100/ 100-100
Evaporator		Flooded												
Water storage	(gal)	29	32	34	36	40	39	43	67	72	72	83	86	91
2 pass arrangement														
Min flow	(gpm)	193	214	202	217	241	217	241	339	375	375	404	422	461
Max flow	(gpm)	709	785	741	796	883	796	883	1243	1374	1374	1483	1548	1690
Water conn	(NPS-in)	4	4	6	6	6	6	6	8	8	8	8	8	8
3 pass arrangement														
Min flow	(gpm)	129	143	135	145	161	145	161	226	250	250	270	282	307
Max flow	(gpm)	473	523	494	531	589	531	589	829	916	916	989	1032	1127
Water conn	(NPS-in)	3.5	3.5	4	4	4	4	4	6	6	6	8	8	8
Condenser		Fin and tube												
Qty of coils	#	4	4	4	4	4	4	4	8	8	8	8	8	8
Coil length	(in)	156/ 156	180/ 156	180/ 180	216/ 180	216/ 216	252/ 216	252/ 252	180/108	216/144	252/144	216/216	252/216	252/252
Coil height	(in)	42	42	42	42	42	42	42	42	42	42	42	42	42
Number of rows	#	3	3	3	3	3	3	3	3	3	3	3	3	3
Fins per foot	(fpf)	192	192	192	192	192	192	192	192	192	192	192	192	192
Fan		Direct drive propeller												
Quantity	#	4/4	5/4	5/5	6/5	6/6	7/6	7/7	10/6	12/6	14/6	12/12	14/12	14/14
Diameter	(in)	30	30	30	30	30	30	30	30	30	30	30	30	30
Air flow per fan	(cfm)	62484	68819	7558	7557	7557	7558	7559	7561	7943	7906	7557	7490	7559
Power/motor	(hp)	1.0	1.0	1.0	1.0	1.0	1.0	1.0	1.0	1.0	1.0	1.0	1.0	1.0
Fan speed	(rpm)	950	950	950	950	950	950	950	950	950	950	950	950	950
Tip speed	(Ft/min)	7461	7461	7461	7461	7461	7461	7461	7461	7461	7461	7461	7461	7461
General unit		HFC-134a												
# refrig ckts	#	2	2	2	2	2	2	2	2	2	2	2	2	2
% min load	%	15	15	15	15	15	15	15	15	15	15	15	15	15
Refrig charge	(lb)	165/ 165	175/ 165	175/ 175	215/ 205	215/ 215	225/ 215	225/ 225	365/200	415/ 200	460/ 200	415/ 415	460/ 415	460/ 460
Oil charge	(gal)	1.3/1.3	1.3/1.3	1.3/1.3	1.3/1.3	1.3/1.3	1.9/1.3	1.9/1.9	2.1-2.1/ 1.9	2.1-2.1/ 1.9	2.3-2.3/ 1.9	2.1-2.1/ 2.1-2.1	2.3-2.3/ 2.3-2.3	2.3-2.3/ 2.3-2.3
Min ambient-std	(°F)	25	25	25	25	25	25	25	25	25	25	25	25	25
Min ambient-low	(°F)	0	0	0	0	0	0	0	0	0	0	0	0	0

1. Data containing information on two circuits is shown as follows: ckt 1/ ckt 2.
2. Minimum start-up/operating ambient is based on a 5 mph wind across the condenser.
3. RTAC units must only operate with refrigerant R-134a and Trane Oil 00048.



General Data

Table 9. General Data - 50 hz units - standard efficiency - SI

Size		140	155	170	185	200	250	275	300	350	375	400
Compressor		Screw										
Quantity	#	2	2	2	2	2	3	3	3	4	4	4
Nominal size@50Hz	(tons)	70/70	85/70	85/85	100/85	100/100	70-70 / 100	85-85 / 100	100-100/ 100	85-85/ 85-85	100-100/ 85-85	100-100/ 100-100
Evaporator		Flooded										
Water storage	(L)	110	121	129	136	151	212	235	254	284	299	314
2 pass arrangement												
Min flow	(L/s)	12	14	13	14	15	17	19	21	22	24	25
Max flow	(L/s)	45	50	47	50	56	61	72	78	81	88	94
Water conn	(NPS-in)	4	4	6	6	6	8	8	8	8	8	8
3 pass arrangement												
Min flow	(L/s)	8	9	9	9	10	11	13	14	15	16	17
Max flow	(L/s)	30	33	31	34	37	41	48	52	54	59	62
Water conn	(NPS-in)	3.5	3.5	4	4	4	6	6	6	8	8	8
Condenser		Fin and tube										
Qty of coils	#	4	4	4	4	4	8	8	8	8	8	8
Coil length	(mm)	3962/ 3962	4572/ 3962	4572/ 4572	5486/ 4572	5486/ 5486	3962/ 2743	4572/ 2743	5486/ 2743	4572/ 4572	5486/ 4572	5486/ 5486
Coil height	(mm)	1067	1067	1067	1067	1067	1067	1067	1067	1067	1067	1067
Number of rows	#	3	3	3	3	3	3	3	3	3	3	3
Fins per foot	(fpf)	192	192	192	192	192	192	192	192	192	192	192
Fan		Direct drive propeller										
Quantity	#	4/4	5/4	5/5	6/5	6/6	8/6	10/6	12/6	10/10	12/10	12/12
Diameter	(mm)	762	762	762	762	762	762	762	762	762	762	762
Air flow per fan	(m ³ /hr)	13452	13120	12855	12855	12855	13190	12853	12856	12854	12855	12855
Power per motor	(kW)	.74	.74	.74	.74	.74	.74	.74	.74	.74	.74	.74
Fan speed	(rps)	15.8	15.8	15.8	15.8	15.8	15.8	15.8	15.8	15.8	15.8	15.8
Tip speed	M/S	38	38	38	38	38	38	38	38	38	38	38
General unit		HFC-134a										
# refriger ckt	#	2	2	2	2	2	2	2	2	2	2	2
% min load	%	15	15	15	15	15	15	15	15	15	15	15
Refrig charge	(kg)	79/79	98/93	98/98	102/98	102/102	107/107	107/107	188/91	209/91	188/188	209/209
Oil charge	(L)	5/5	5/5	5/5	7/5	7/7	8-8/7	8-8/7	8-8/7	8-8/8-8	9-9/8-8	9-9/9-9
Min ambient-std	(°C)	-3.9	-3.9	-3.9	-3.9	-3.9	-3.9	-3.9	-3.9	-3.9	-3.9	-3.9
Min ambient-low	(°C)	-17.8	-17.8	-17.8	-17.8	-17.8	-17.8	-17.8	-17.8	-17.8	-17.8	-17.8

1. Data containing information on two circuits is shown as follows: ckt 1/ ckt 2.
2. Minimum start-up/operating ambient is based on a 5 mph wind across the condenser.
3. RTAC units must only operate with refrigerant R-134a and Trane Oil 00048.

Table 10. General Data - 50 hz units - high efficiency - SI

Size		120	130	140	155	170	185	200	250	275	300	350	375	400
Compressor		Screw												
Quantity	#	2	2	2	2	2	2	2	3	3	3	4	4	4
Nominal size@50Hz	(tons)	60/60	70/60	70/70	85/70	85/85	100/85	100/100	70-70 / 100	85-85 / 100	100-100/ 100	85-85 / 85-85	100-100/ 85-85	100-100/ 100-100
Evaporator		Flooded												
Water storage	(L)	110	121	129	136	151	148	163	254	273	273	314	326	344
2 pass arrangement														
Min flow	(L/s)	12	14	13	14	15	14	15	21	24	24	25	27	29
Max flow	(L/s)	45	50	47	50	56	50	56	78	87	87	94	98	107
Water conn	(NPS-in)	4	4	6	6	6	6	6	8	8	8	8	8	8
3 pass arrangement														
Min flow	(L/s)	8	9	9	9	10	9	10	14	16	16	17	18	19
Max flow	(L/s)	30	33	31	34	37	34	37	52	58	58	62	65	71
Water conn	(NPS-in)	3.5	3.5	4	4	4	4	4	6	6	6	8	8	8
Condenser		Fin and tube												
Qty of coils	#	4	4	4	4	4	4	4	8	8	8	8	8	8
Coil length	(mm)	3962/ 3962	4572/ 3962	4572/ 4572	5486/ 4572	5486/ 5486	6400/ 5486	6400/ 6400	4572/ 2743	5486/ 3657	6400/ 3657	5486/ 5486	6400/ 5486	6400/ 6400
Coil height	(mm)	1067	1067	1067	1067	1067	1067	1067	1067	1067	1067	1067	1067	1067
Number of rows	#	3	3	3	3	3	3	3	3	3	3	3	3	3
Fins per foot	(fpf)	192	192	192	192	192	192	192	192	192	192	192	192	192
Fan		Direct drive propeller												
Quantity	#	4/4	5/4	5/5	6/5	6/6	7/6	7/7	10/6	12/6	14/6	12/12	14/12	14/14
Diameter	(mm)	762	762	762	762	762	762	762	762	762	762	762	762	762
Air flow per fan	(m ³ /hr)	62484	68819	12839	12839	12839	12840	12842	12844	13493	13430	12838	12724	12841
Power/motor	(kW)	.74	.74	.74	.74	.74	.74	.74	.74	.74	.74	.74	.74	.74
Fan speed	(rps)	15.8	15.8	15.8	15.8	15.8	15.8	15.8	15.8	15.8	15.8	15.8	15.8	15.8
Tip speed	M/S	38	38	38	38	38	38	38	38	38	38	38	38	38
General unit		HFC-134a												
# refrig ckts	#	2	2	2	2	2	2	2	2	2	2	2	2	2
% min load	%	15	15	15	15	15	15	15	15	15	15	15	15	15
Refrig charge	(kg)	75/75	79/75	79/79	98/93	98/98	102/95	102/ 102	166/91	188/91	209/ 91	188/ 188	209/ 188	209/ 209
Oil charge	(L)	5/5	5/5	5/5	5/5	5/5	7/5	7/7	8-8/ 7	8-8/ 7	8-8/ 7	8-8/ 8-8	9-9/ 9-9	9-9/ 9-9
Min ambient-std	(°C)	-3.9	-3.9	-3.9	-3.9	-3.9	-3.9	-3.9	-3.9	-3.9	-3.9	-3.9	-3.9	-3.9
Min ambient-low	(°C)	-17.8	-17.8	-17.8	-17.8	-17.8	-17.8	-17.8	-17.8	-17.8	-17.8	-17.8	-17.8	-17.8

1. Data containing information on two circuits is shown as follows: ckt 1/ ckt 2.
2. Minimum start-up/operating ambient is based on a 5 mph wind across the condenser.
3. RTAC units must only operate with refrigerant R-134a and Trane Oil 00048.



Pre-installation

Unit Inspection

When unit is delivered, verify it is the correct unit and is properly equipped.

If unit is covered with optional tarp, confirm unit was ordered with a tarp. Inspect tarp for any visible damage.

If unit does not have optional tarp, compare information on unit nameplate with ordering and submittal information. Inspect all exterior components for visible damage.

Report any apparent damage or material shortage to carrier and make a "unit damage" notation on carrier's delivery receipt. Specify extent and type of damage found and notify Trane Sales Office. Do not proceed with installation of a damaged unit without sales office approval.

Inspection Checklist

To protect against loss due to damage in transit, complete this checklist upon receipt of unit.

- Inspect the individual pieces of the shipment before accepting the unit. Check for obvious damage to the unit or packing material.
- Inspect the unit for concealed damage as soon as possible after delivery and before it is stored. Concealed damage must be reported within 15 days.
- If concealed damage is discovered, stop unpacking the shipment. Do not remove damaged material from the receiving location. Take photos of the damage, if possible. The owner must provide reasonable evidence that the damage did not occur after delivery.
- Notify the carrier's terminal of the damage immediately, by phone and by mail. Request an immediate, joint inspection of the damage with the carrier and the consignee.

Notify Trane sales representative and arrange for repair. Do not repair unit until damage is inspected by the carrier's representative.

Storage

Extended storage of outdoor unit prior to installation requires these precautionary measures:

- Store the outdoor unit in a secure area.
- At least every three months (quarterly), check the pressure in the refrigerant circuits to verify that the refrigerant charge is intact. If it is not, contact a qualified service organization and the appropriate Trane sales office.
- Close the discharge and liquid line isolation valves.

Installation Responsibilities

Generally, the contractor must do the following when installing an RTAC unit:

- Install unit on a flat foundation, level (within 1/4" [6 mm] across the length and width of the unit), and strong enough to support unit loading.
- Install unit per the instructions contained in the Installation-Mechanical and Installation-Electrical sections of this manual.
- Install any optional sensors and make electrical connections at the CH530.
- Where specified, provide and install valves in water piping upstream and downstream of evaporator water connections to isolate evaporator for maintenance, and to balance/trim system.
- Furnish and install pressure gauges in inlet and outlet piping of the evaporator.
- Furnish and install a drain valve to the bottom of the evaporator waterbox.
- Supply and install a vent cock to the top of the evaporator waterbox.
- Furnish and install strainers ahead of all pumps and automatic modulating valves, and at inlet of evaporator.
- Provide and install field wiring.
- Install heat tape and insulate the chilled water lines and any other portions of the system, as required, to prevent sweating under normal operating conditions or freezing during low ambient temperature conditions.
- Install evaporator drain plug. The plug ships in unit control panel.
- Start unit under supervision of a qualified service technician.

General

Report any damage incurred during handling or installation to the Trane sales office immediately.



Dimensions and Weights

Dimensions

See unit submittals for specific unit dimensions and water connection locations.

Clearances

Provide enough space around the outdoor unit to allow the installation and maintenance personnel unrestricted

access to all service points. Refer to submittal drawings for the unit dimensions. A minimum of 4 feet (1.2 m) is recommended for compressor service. Provide sufficient clearance for the opening of control panel doors. See [Figure 5, p. 21](#) through [Figure 9, p. 23](#) for minimum clearances. In all cases, local codes which require additional clearances will take precedence over these recommendations.

Figure 5. Recommended unit clearance – 15 foot bases

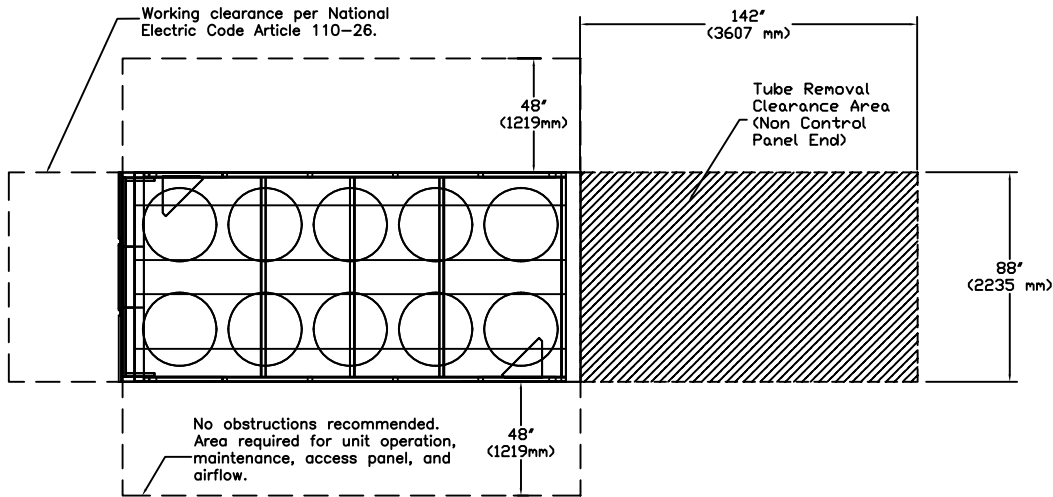

Figure 6. Recommended unit clearances 18-21 foot bases

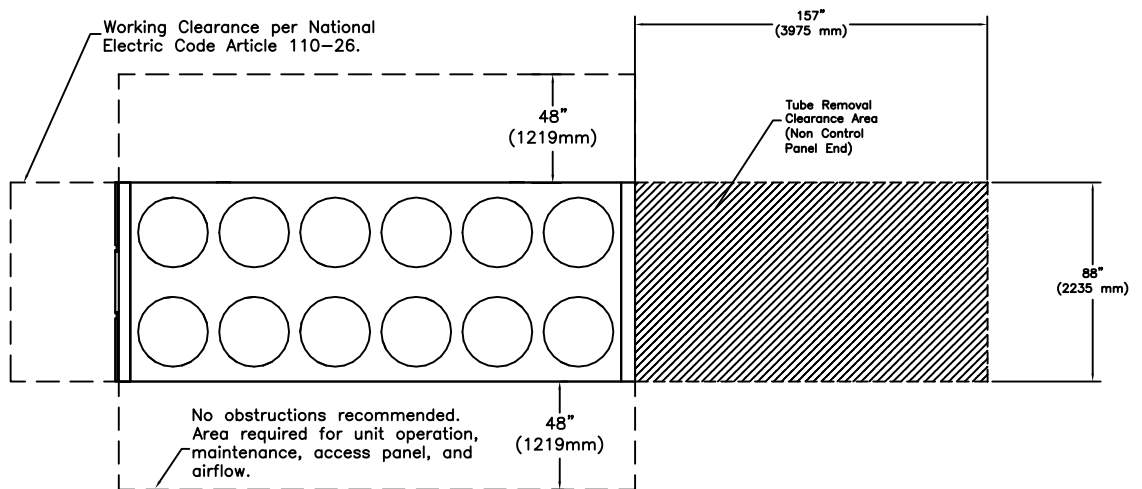

Figure 7. Recommended unit clearances 30-45 foot bases

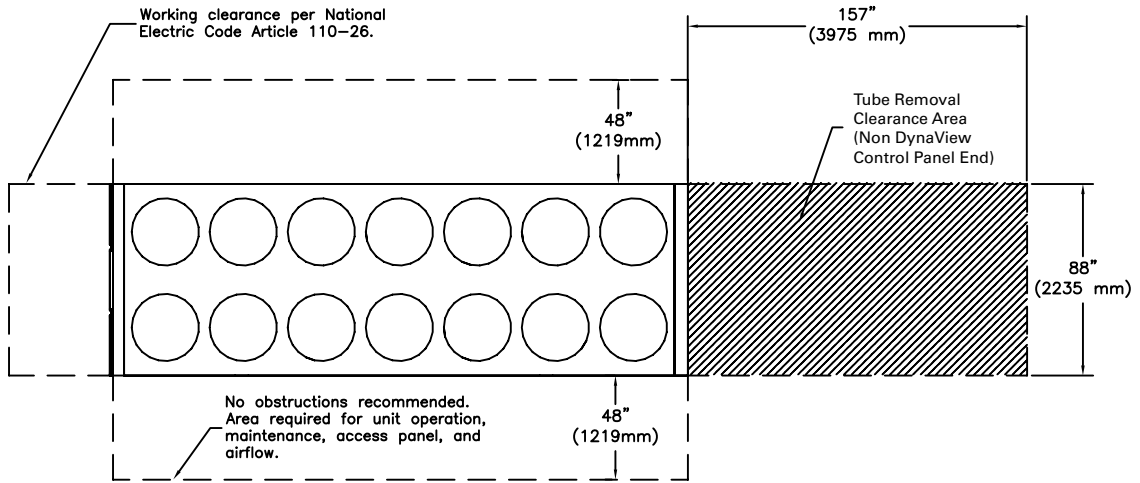

Figure 8. Recommended remote evaporator unit clearances – 15-30 foot bases

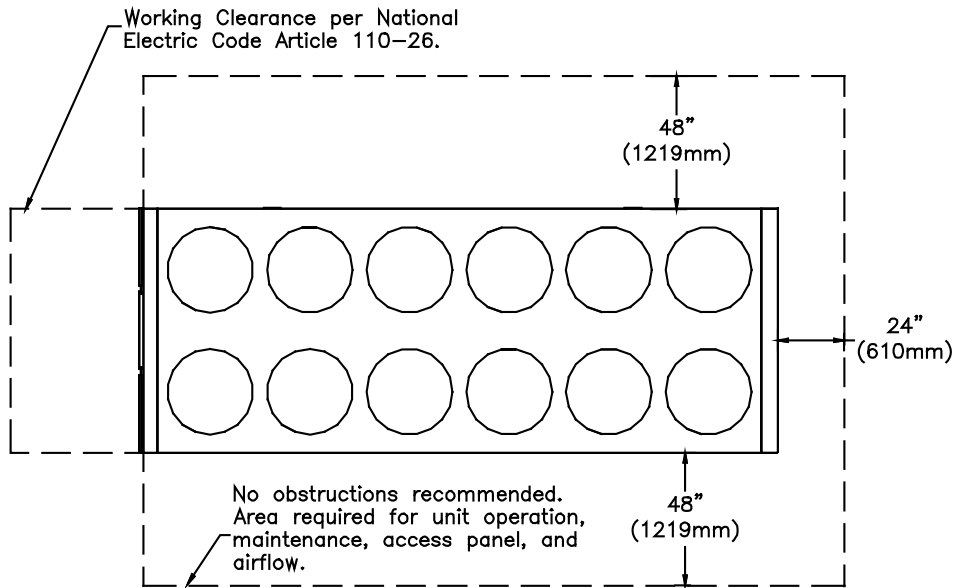
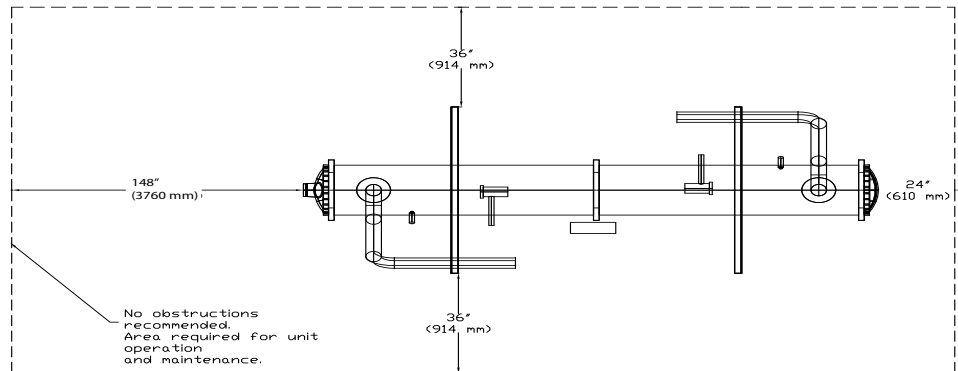

Figure 9. Recommended evaporator clearance

Unobstructed flow of condenser air is essential to maintain chiller capacity and operating efficiency. When determining unit placement, give careful consideration to assuring a sufficient flow of air across the condenser heat transfer surface. Two detrimental conditions are possible and must be avoided if optimum performance is to be achieved: warm air recirculation and coil starvation.

Warm air recirculation occurs when discharge air from the condenser fans is recycled back to the condenser coil inlet. Coil starvation occurs when free airflow to (or from) the condenser is restricted.

Both warm air recirculation and coil starvation cause reduction in unit efficiency and capacity due to the increased head pressures.

Debris, trash, supplies etc. should not be allowed to accumulate in the vicinity of the unit. Supply air movement may draw debris into the condenser coil, blocking spaces between coil fins and causing coil starvation. Special consideration should be given to low ambient units. Condenser coils and fan discharge must be kept free of snow or other obstructions to permit adequate airflow for satisfactory unit operation.

In situations where equipment must be installed with less clearance than recommended, such as frequently occurs in retrofit and rooftop applications, restricted airflow is common. The Main Processor will direct the unit to make as much chilled water as possible given the actual installed conditions. Consult your Trane sales engineer for more details.

Note: *If the outdoor unit configuration requires a variance to the clearance dimensions, contact your Trane Sales Office Representative. Also refer to Trane Engineering Bulletins for application information on RTAC chillers.*



Dimensions and Weights

Weights

Non-Seismically Rated Units

Table 11. Weight - packaged units - 60 Hz - aluminum or CompleteCoat coils

Unit Size (tons)	Standard Efficiency				High Efficiency				Extra Efficiency			
	Shipping		Operating		Shipping		Operating		Shipping		Operating	
	lb	kg	lb	kg	lb	kg	lb	kg	lb	kg	lb	kg
140	10832	4913	11146	5056	10859	4926	11160	5062	12171	5521	12585	5708
155	10910	4949	11146	5056	12114	5495	12445	5645	13984	6343	14293	6483
170	10877	4934	11218	5088	12171	5521	12585	5708	14454	6556	14721	6677
185	12479	5660	12899	5851	13984	6343	14293	6483	15915	7219	16413	7445
200	12884	5844	13193	5984	14454	6556	14721	6677	16016	7265	16413	7445
225	14635	6638	14966	6788	15915	7219	16413	7445	n/a			
250	14916	6766	15191	6890	16016	7265	16413	7445	20476	9288	21048	9547
275	19025	8630	19685	8929	20393	9250	21048	9547	21667	9828	22160	10052
300	20699	9389	21214	9622	21667	9828	22160	10052	24073	10919	24700	11204
350	21550	9775	22005	9981	24073	10919	24700	11204	27136	12309	27750	12587
400	25409	11525	25854	11727	27136	12309	27750	12587	n/a			
450	26816	12163	27393	12425	n/a				n/a			
500	27136	12309	27912	12661	n/a				n/a			

1. Operating weight includes refrigerant and water.
2. Shipping weight includes refrigerant.
3. All weights +/- 3%.

Table 12. Weight - packaged units - 60 Hz - copper coils

Unit Size (tons)	Standard Efficiency				High Efficiency				Extra Efficiency			
	Shipping		Operating		Shipping		Operating		Shipping		Operating	
	lb	kg	lb	kg	lb	kg	lb	kg	lb	kg	lb	kg
140	13407	6081	13734	6230	13426	6090	13734	6230	15590	7071	15998	7257
155	13420	6087	13734	6230	15647	7097	15854	7191	18250	8278	18613	8443
170	13442	6097	13733	6229	15590	7071	15998	7257	18701	8483	18958	8599
185	15870	7198	16253	7372	18250	8278	18613	8443	20794	9432	21290	9657
200	16304	7395	16630	7543	18701	8483	18958	8599	20881	9471	21290	9657
225	18739	8500	18156	8235	20794	9432	21290	9657	n/a			
250	18905	8575	19223	8719	20881	9471	21290	9657	26017	11801	26558	12046
275	23905	10843	24608	11162	26017	11801	26558	12046	27660	12546	28182	12783
300	26039	11811	26580	12056	27660	12546	28182	12783	30848	13992	31431	14257
350	27395	12426	27920	12664	30848	13992	31431	14257	35166	15951	35688	16188
400	32216	14613	32723	14843	35014	15882	35688	16188	n/a			
450	32682	14824	33178	15049	n/a				n/a			
500	35014	15882	35787	16233	n/a				n/a			

1. Operating weight includes refrigerant and water.
2. Shipping weight includes refrigerant.
3. All weights +/- 3%.

Table 13. Weight - packaged units - 50 Hz - aluminum or CompleteCoat coils

Unit Size (tons)	Standard Efficiency				High Efficiency			
	Shipping		Operating		Shipping		Operating	
	lb	kg	lb	kg	lb	kg	lb	kg
120		n/a			10832	4913	11146	5056
130		n/a			10910	4949	11146	5056
140	10844	4919	11146	5056	10871	4931	11160	5062
155	11131	5049	11397	5170	12466	5654	12786	5800
170	11426	5183	11632	5276	12742	5780	12990	5892
185	12797	5805	13111	5947	14383	6524	14754	6692
200	12962	5879	13304	6035	14516	6584	14967	6789
250	18051	8188	19186	8703	19176	8698	20483	9291
275	19715	8943	20240	9181	21944	9954	21532	9767
300	20242	9182	21027	9538	22272	10102	22185	10063
350	23231	10537	23799	10795	24924	11305	25812	11708
375	24360	11049	25213	11436	26298	11929	26963	12230
400	25222	11440	25854	11727	27120	12301	27751	12588

1. Operating weight includes refrigerant and water.
2. Shipping weight includes refrigerant.
3. All weights +/- 3%.

Table 14. Weight - packaged units - 50 Hz - copper coils

Unit Size (tons)	Standard Efficiency				High Efficiency			
	Shipping		Operating		Shipping		Operating	
	lb	kg	lb	kg	lb	kg	lb	kg
120		n/a			13407	6081	13734	6230
130		n/a			13426	6090	13734	6230
140	13417	6086	13734	6230	13446	6099	13734	6230
155	13851	6283	13962	6333	15772	7154	16192	7345
170	13856	6285	14366	6516	16162	7331	17421	7902
185	16216	7355	16463	7467	18570	8423	18979	8609
200	16381	7430	16721	7584	18833	8542	19223	8719
250	22058	10005	21837	9905	24015	10893	24056	10912
275	24584	11151	25095	11383	26617	12073	27135	12308
300	25893	11745	26336	11946	27617	12527	28182	12783
350	29084	13192	29527	13393	32037	14532	32712	14838
375	30432	13804	30971	14048	32463	14725	32971	14955
400	32112	14566	32787	14872	34982	15867	35525	16114

1. Operating weight includes refrigerant and water.
2. Shipping weight includes refrigerant.
3. All weights +/- 3%.



Dimensions and Weights

Seismically Rated Unit Weights

Table 15. Weight - seismically rated - packaged units - 60 Hz - aluminum or CompleteCoat coils

Unit Size (tons)	Standard Efficiency				High Efficiency				Extra Efficiency			
	Shipping		Operating		Shipping		Operating		Shipping		Operating	
	lb	kg	lb	kg	lb	kg	lb	kg	lb	kg	lb	kg
140	11374	5159	11646	5283	11402	5172	11711	5312	12780	5797	13185	5981
155	11456	5196	11703	5308	12720	5770	13067	5927	14683	6660	15021	6813
170	11421	5180	11779	5343	12780	5797	13214	5994	15177	6884	15433	7000
185	13103	5943	13544	6143	14683	6660	15008	6807	16711	7580	17234	7817
200	13528	6136	13853	6284	15177	6884	15457	7011	16817	7628	17234	7817
225	15367	6970	15714	7128	16711	7580	17234	7817	n/a			
250	15662	7104	15951	7235	16817	7628	17234	7817	21500	9752	22100	10025
275	19976	9061	20669	9375	21413	9713	22100	10025	22750	10319	23268	10554
300	21734	9858	22275	10104	22750	10319	23268	10554	25277	11465	25935	11764
350	22628	10264	23105	10480	25277	11465	25935	11764	28493	12924	29138	13216
400	26679	12102	27147	12313	28493	12924	29138	13216	n/a			
450	28157	12772	28763	13046	n/a				n/a			
500	28493	12924	29308	13294	n/a				n/a			

1. Operating weight includes refrigerant and water.
2. Shipping weight includes refrigerant.
3. All weights +/- 3%.

Remote Evaporator Unit Weights

Table 16. Weights - condensing unit - 60 Hz

Unit Size (tons)	Standard Efficiency				High Efficiency			
	Shipping		Operating		Shipping		Operating	
	lb	kg	lb	kg	lb	kg	lb	kg
Aluminum or CompleteCoat™ coils								
140	8359	3792	8624	3912	8292	3761	8624	3912
155	8299	3764	8624	3912	9460	4291	9931	4505
170	8304	3767	8624	3912	10610	4813	9944	4510
185	10944	4964	10226	4638	11060	5017	11512	5222
200	11179	5071	10625	4819	11443	5190	11886	5391
225	11531	5230	11997	5442	-	-	-	-
250	11623	5272	12126	5500	-	-	-	-
Copper Coils								
140	10956	4970	11200	5080	10751	4877	11200	5080
155	10973	4977	11200	5080	12916	5859	13340	6051
170	10877	4934	11200	5080	13451	6101	13375	6067
185	13610	6173	13645	6189	15326	6952	15778	7157
200	13665	6198	14048	6372	15707	7125	16148	7325
225	15795	7164	16252	7372	-	-	-	-
250	15888	7207	16386	7433	-	-	-	-

1. Operating weight includes refrigerant and water.
2. Shipping weight includes nitrogen holding charge.
3. All weights +/- 3%.

Table 17. Weights - remote evaporator - 60 Hz

Nominal Tonnage	Standard Efficiency				High Efficiency			
	Shipping Weight (lb)	Shipping Weight (kg)	Operating Weight (lb)	Operating Weight (kg)	Shipping Weight (lb)	Shipping Weight (kg)	Operating Weight (lb)	Operating Weight (kg)
140	2486	1128	2730	1238	2528	1147	2805	1272
155	2525	1145	2790	1266	2556	1159	2850	1293
170	2528	1147	2805	1272	2600	1179	2920	1325
185	2556	1159	2850	1293	2797	1269	3114	1413
200	2600	1179	2920	1325	2846	1291	3192	1448
225	2797	1269	3114	1413	-	-	-	-
250	2846	1291	3192	1448	-	-	-	-

1. Operating weight includes refrigerant and water.
2. Shipping weight includes nitrogen holding charge.
3. All weights +/- 3%.



Installation - Mechanical

Location Requirements

Noise Considerations

Locate outdoor unit away from sound sensitive areas. If required, install rubber vibration isolators in all water piping and use flexible electrical conduit. Consult an acoustical engineer for critical applications. Also refer to Trane Engineering Bulletins for application information on RTAC chillers.

Foundation

A base or foundation is not required if unit location is level and strong enough to support unit's operating weight as listed in "General Data," p. 9, Table 1, p. 10 through Table 10, p. 19. Provide rigid, non-warping mounting pads or concrete foundation of sufficient strength and mass to support unit operating weight (including piping, and full operating charges of refrigerant, oil and water). Once in place, outdoor unit must be level within 1/4" (6 mm) over its length and width.

Trane Company is not responsible for equipment problems resulting from an improperly designed or constructed foundation.

Note: *To allow for cleaning under the condensing coil, it is recommended that an opening be left between the unit base and the concrete pad.*

Clearances

Provide enough space around the outdoor unit to allow the installation and maintenance personnel unrestricted access to all service points. Refer to submittal drawings for the unit dimensions. A minimum of 4 feet (1.2 m) is recommended for compressor service. Provide sufficient clearance for the opening of control panel doors. See Figure 5, p. 21 through Figure 9, p. 23 in "Dimensions and Weights," p. 21 for minimum clearances. In all cases, local codes which require additional clearances will take precedence over these recommendations.

Rigging

Lifting Procedure

⚠ WARNING

Heavy Objects!

Ensure that all the lifting equipment used is properly rated for the weight of the unit being lifted. Each of the cables (chains or slings), hooks, and shackles used to lift the unit must be capable of supporting the entire weight of the unit. Lifting cables (chains or slings) may not be of the same length. Adjust as necessary for even unit lift. Other lifting arrangements could cause equipment or property damage. Failure to follow instructions above or properly lift unit could result in unit dropping and possibly crushing operator/ technician which could result in death or serious injury.

⚠ WARNING

Improper Unit Lift!

Test lift unit approximately 24 inches to verify proper center of gravity lift point. To avoid dropping of unit, reposition lifting point if unit is not level. Failure to properly lift unit could result in unit dropping and possibly crushing operator/technician which could result in death or serious injury and possible equipment or property-only damage.

⚠ WARNING

Heavy Objects!

Ensure that all the lifting equipment used is properly rated for the weight of the unit being lifted. Each of the cables (chains or slings), hooks, and shackles used to lift the unit must be capable of supporting the entire weight of the unit. Lifting cables (chains or slings) may not be of the same length. Adjust as necessary for even unit lift. Other lifting arrangements could cause equipment or property damage. Failure to follow instructions above or properly lift unit could result in unit dropping and possibly crushing operator/ technician which could result in death or serious injury.

Important: *Do not fork lift unit.*

See Table 18, p. 30 through Table 22, p. 32 for lifting weights and Table 23, p. 33 and Table 24, p. 33 for center of gravity (CG) dimensions.

Rigging

See Figure 10 through Figure 12, p. 29 for lifting point references, Table 19 through Table 21 for lifting weights, and unit submittals lift point dimensions.

Figure 10. Lifting the unit (packaged and remote) 15-21 foot base

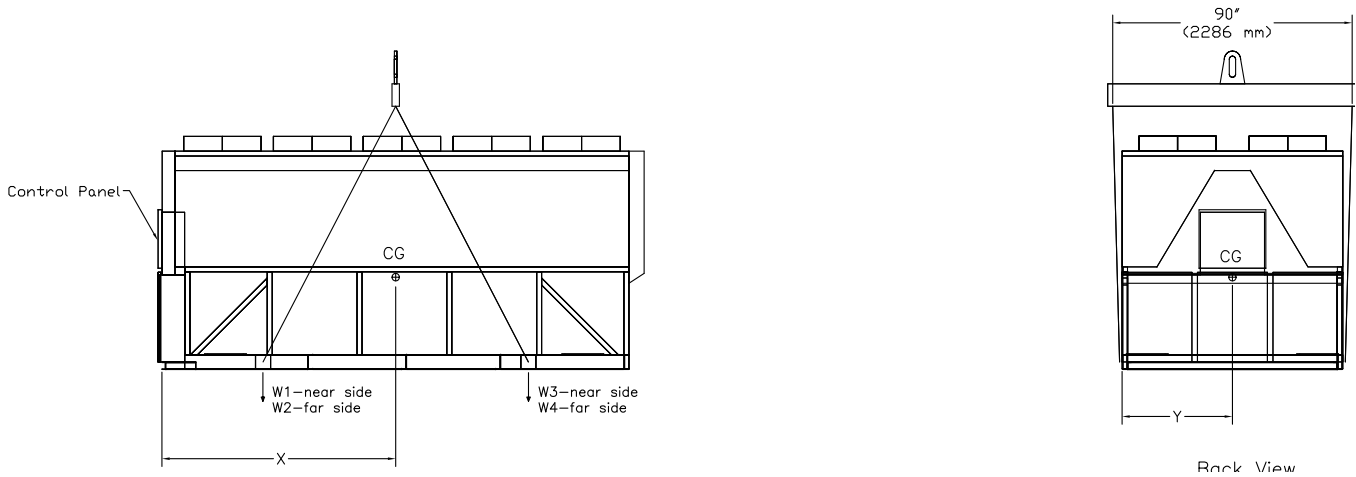

Figure 11. Lifting the unit (packaged and remote) 30-36 foot base

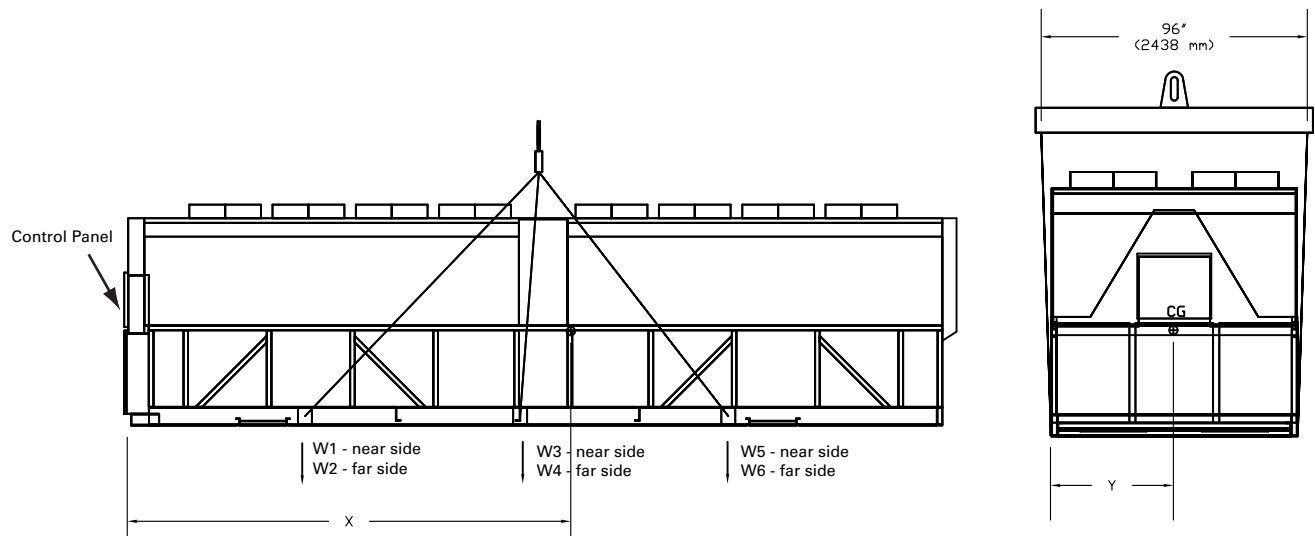

Figure 12. Lifting the unit (packaged and remote) 39-45 foot base

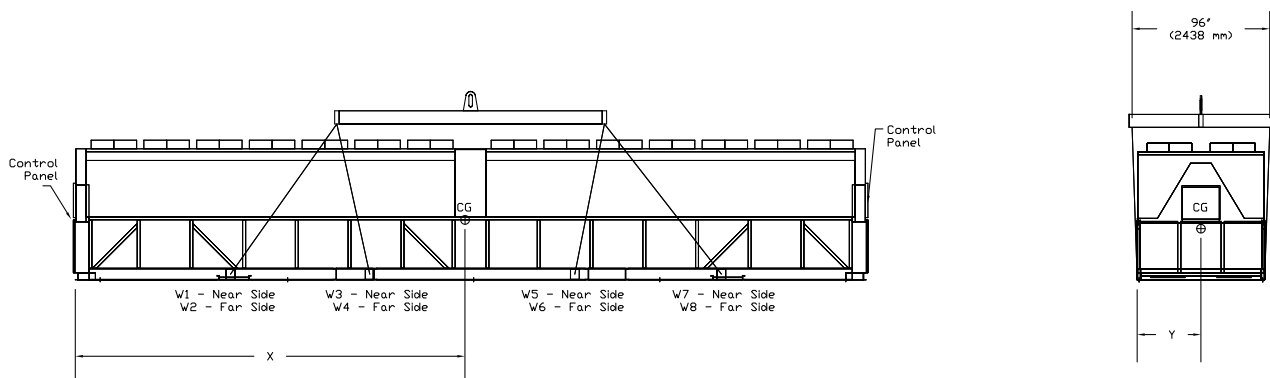
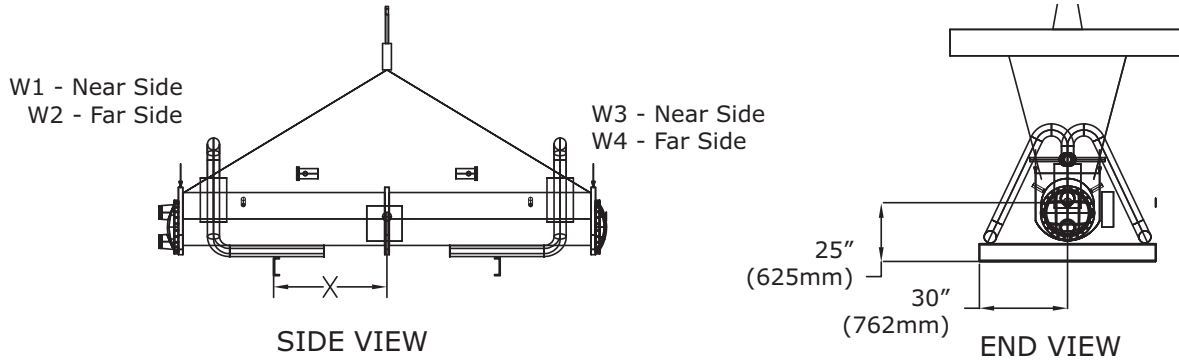

Figure 13. Lifting the remote evap



Lifting Weights Tables

Table 18. Lifting weights (lbs) - packaged units - 60 Hz

Size (tons)	Lifting Location							
	W1	W2	W3	W4	W5	W6	W7	W8
Aluminum Coils - Standard Efficiency								
140	2443	2814	2622	2953	-	-	-	-
155	2446	2881	2627	2956	-	-	-	-
170	2447	2831	2633	2966	-	-	-	-
185	3244	3584	2656	2995	-	-	-	-
200	3285	3701	2741	3157	-	-	-	-
225	3943	4177	3183	3332	-	-	-	-
250	3657	4167	3518	3574	-	-	-	-
275	3376	2957	3372	2975	3377	2968	-	-
300	3470	3099	3640	3258	3814	3418	-	-
350	3389	3023	3787	3382	4187	3782	-	-
400	3448	3315	3226	3205	3123	3102	3026	2964
450	3440	3419	3324	3303	3154	3133	3032	4011
500	3373	3299	3405	3331	3452	3378	3486	3412
Aluminum Coils - High Efficiency								
140	2446	2820	2630	2963	-	-	-	-
155	3114	3508	2549	2943	-	-	-	-
170	3124	3524	2561	2962	-	-	-	-
185	3469	4059	2933	3523	-	-	-	-
200	3657	4139	3135	3523	-	-	-	-
225	2581	2904	2489	2812	2400	2729	-	-
250	2607	2904	2518	2825	2433	2729	-	-
275	3272	2884	3592	3204	3915	3526	-	-
300	2974	2647	2911	2584	2801	2514	2785	2451
350	2936	2876	3003	2943	3075	3015	3143	3082
400	3373	3299	3405	3331	3452	3378	3486	3412
Aluminum Coils - Extra Efficiency								
140	3124	3524	2561	2962	-	-	-	-
155	3469	4059	2933	3523	-	-	-	-
170	3657	4139	3135	3523	-	-	-	-
185	2581	2904	2489	2812	2400	2729	-	-
200	2607	2904	2518	2825	2433	2729	-	-
250	3272	2884	3592	3204	3998	3526	-	-
275	2974	2647	2911	2584	2801	2514	2785	2451
300	2936	2876	3003	2943	3075	3015	3143	3082
350	3373	3299	3405	3331	3452	3378	3486	3412

Table 18. Lifting weights (lbs) - packaged units - 60 Hz

Size (tons)	Lifting Location							
	W1	W2	W3	W4	W5	W6	W7	W8
Copper Coils - Standard Efficiency								
140	2916	3405	3346	3740	-	-	-	-
155	2919	3405	3352	3744	-	-	-	-
170	2920	3412	3357	3753	-	-	-	-
185	3991	4450	3500	3929	-	-	-	-
200	4032	4567	3585	4120	-	-	-	-
225	4593	5261	4101	4784	-	-	-	-
250	4639	5261	4149	4856	-	-	-	-
275	4319	3898	4170	3772	4078	3668	-	-
300	4513	3980	4552	4169	4618	4207	-	-
350	4289	3892	4769	4363	5244	4838	-	-
400	4220	4198	4100	4078	3975	3953	3857	3835
450	4549	4526	4290	4268	3909	3887	3638	3615
500	4369	4293	4395	4319	4434	4358	4461	4385
Copper Coils - High Efficiency								
140	2919	3410	3354	3743	-	-	-	-
155	3973	4374	3393	3907	-	-	-	-
170	3870	4390	3405	3925	-	-	-	-
185	4404	5144	3981	4721	-	-	-	-
200	4593	5223	4101	4784	-	-	-	-
225	3189	3625	3247	3685	3303	3745	-	-
250	3214	3625	3276	3685	3336	3745	-	-
275	4235	3898	4522	4132	4810	4420	-	-
300	3818	3527	3708	3379	3545	3216	3398	3069
350	4054	4035	3930	3911	3800	3781	3678	3659
400	4369	4293	4395	4319	4434	4358	4461	4385
Copper Coils - Extra Efficiency								
140	3870	4390	3405	3925	-	-	-	-
155	4404	5144	3981	4721	-	-	-	-
170	4593	5223	4101	4784	-	-	-	-
185	3189	3625	3247	3685	3303	3745	-	-
200	3214	3625	3276	3685	3336	3745	-	-
250	4235	3898	4522	4132	4810	4420	-	-
275	3818	3527	3708	3379	3545	3216	3398	3069
300	4054	4035	3930	3911	3800	3781	3678	3659
350	4521	4293	4395	4319	4434	4358	4461	4385

Table 19. Lifting weights (lbs) - packaged units - 50 Hz

Size (tons)	Lifting Location							
	W1	W2	W3	W4	W5	W6	W7	W8
Aluminum Coils - Standard Efficiency								
140	2445	2817	2625	2957	-	-	-	-
155	2556	2837	2750	2988	-	-	-	-
170	2554	2946	2793	3133	-	-	-	-
185	3287	3708	2690	3112	-	-	-	-
200	3302	3721	2760	3179	-	-	-	-
250	2972	2538	3254	2825	3446	3016	-	-
275	4084	3574	3618	3109	2920	2410	-	-
300	3340	2929	3576	3165	3814	3418	-	-
350	3043	3023	2958	2939	2869	2849	2785	2765
375	3347	3315	3135	3101	2911	2878	3005	2668
400	3311	3291	3226	3192	3123	3089	3026	2964
Aluminum Coils - High Efficiency								
120	2443	2814	2622	2953	-	-	-	-
130	2446	2881	2627	2956	-	-	-	-
140	2448	2822	2634	2967	-	-	-	-
155	3230	3537	2696	3003	-	-	-	-
170	3253	3666	2705	3118	-	-	-	-
185	3589	4139	3053	3602	-	-	-	-
200	3703	4139	3100	3574	-	-	-	-
250	3376	2957	3406	2975	3446	3016	-	-
275	4322	3018	3710	3304	3998	3592	-	-
300	2974	2647	2911	2584	2831	3089	2785	2451
350	3311	3291	3204	3184	3100	2847	3005	2982
375	3412	3391	3297	3276	3154	3105	3679	2984
400	3373	3299	3389	3331	3452	3378	3486	3412
Copper Coils - Standard Efficiency								
140	2918	3407	3349	3743	-	-	-	-
155	3030	3428	3474	3919	-	-	-	-
170	3027	3536	3518	3775	-	-	-	-
185	4033	4574	3534	4075	-	-	-	-
200	4048	4586	3604	4143	-	-	-	-
250	3550	3120	3934	3504	4190	3760	-	-
275	4632	4157	4297	3822	4078	3598	-	-
300	4387	4130	4488	4076	4618	4194	-	-
350	3803	3782	3700	3679	3591	3570	3490	3469
375	4351	4317	4003	3969	3637	3603	3293	3259
400	4207	4185	4087	4065	3962	3940	3844	3822
Copper Coils - High Efficiency								
120	2916	3405	3346	3740	-	-	-	-
130	2919	3405	3352	3750	-	-	-	-
140	2921	3413	3358	3754	-	-	-	-
155	3863	4403	3540	3966	-	-	-	-
170	4000	4532	3549	4081	-	-	-	-
185	4525	5223	4101	4721	-	-	-	-
200	4639	5261	4149	4784	-	-	-	-
250	4319	3898	4204	3772	4127	3695	-	-
275	4387	3980	4639	4232	4893	4486	-	-
300	3845	3517	3698	3369	3535	3206	3388	3059
350	4198	4177	4078	4057	3952	3930	3833	3812
375	4521	4498	4263	4240	3882	3860	3611	3588
400	4369	4293	4395	4319	4418	4358	4461	4369

Table 20. Lifting weights (lbs) - seismically rated units

Size (tons)	Lifting Location							
	W1	W2	W3	W4	W5	W6	W7	W8
Aluminum Coils - Standard Efficiency								
140	2565	2955	2753	3101	-	-	-	-
155	2568	3025	2758	3104	-	-	-	-
170	2569	2973	2765	3114	-	-	-	-
185	3406	3763	2789	3145	-	-	-	-
200	3449	3886	2878	3315	-	-	-	-
225	4140	4386	3342	3499	-	-	-	-
250	3840	4375	3694	3753	-	-	-	-
275	3545	3105	3541	3124	3546	3116	-	-
300	3644	3254	3822	3421	4005	3589	-	-
350	3558	3174	3976	3551	4396	3971	-	-
400	3620	3481	3387	3365	3279	3257	3177	3112
450	3612	3590	3490	3468	3312	3290	3184	4212
500	3542	3464	3575	3498	3625	3547	3660	3583
Aluminum Coils - High Efficiency								
140	2568	2961	2762	3111	-	-	-	-
155	3270	3683	2676	3090	-	-	-	-
170	3280	3700	2689	3110	-	-	-	-
185	3642	4262	3080	3699	-	-	-	-
200	3840	4346	3292	3699	-	-	-	-
225	2710	3049	2613	2953	2520	2865	-	-
250	2737	3049	2644	2966	2555	2865	-	-
275	3436	3028	3772	3364	4111	3702	-	-
300	3123	2779	3057	2713	2941	2640	2924	2574
350	3083	3020	3153	3090	3229	3166	3300	3236
400	3542	3464	3575	3498	3625	3547	3660	3583
Aluminum Coils - Extra Efficiency								
140	3280	3700	2689	3110	-	-	-	-
155	3642	4262	3080	3699	-	-	-	-
170	3840	4346	3292	3699	-	-	-	-
185	2710	3049	2613	2953	2520	2865	-	-
200	2737	3049	2644	2966	2555	2865	-	-
250	3436	3028	3772	3364	4198	3702	-	-
275	3123	2779	3057	2713	2941	2640	2924	2574
300	3083	3020	3153	3090	3229	3166	3300	3236
350	3542	3464	3575	3498	3625	3547	3660	3583



Installation - Mechanical

Table 21. Lifting weights (lbs) - remote evaporator condensing units - 60 Hz

Size (tons)	Standard Efficiency Lifting Location				High Efficiency Lifting Location			
	W1	W2	W3	W4	W1	W2	W3	W4
Aluminum Coils								
140	1993	2303	1899	2164	1993	2236	1899	2164
155	1996	2236	1903	2164	1552	2844	1904	3160
170	1994	2239	1903	2168	2551	2848	1903	3308
185	2682	2920	2011	3331	2837	3315	2215	2693
200	2713	3025	2083	3358	3025	3390	2335	2693
225	3025	3430	2335	2741	-	-	-	-
250	3071	3430	2381	2741	-	-	-	-
Copper Coils								
140	2466	2827	2624	3039	2466	2711	2624	2950
155	2569	2827	2627	2950	3298	3710	2748	3160
170	2467	2829	2627	2954	3417	3845	2881	3308
185	3474	3913	2892	3331	3773	4399	3264	3890
200	3489	3891	2927	3358	3960	4474	3383	3890
225	3960	4514	3383	3938	-	-	-	-
250	4006	4514	3430	3938	-	-	-	-

Table 22. Lifting weights (lbs) - remote evaporators

Size (tons)	Standard Efficiency Lifting Location				High Efficiency Lifting Location			
	W1	W2	W3	W4	W1	W2	W3	W4
Aluminum Coils								
140	621	621	622	622	632	632	632	632
155	632	631	631	631	639	639	639	639
170	632	632	632	632	650	650	650	650
185	639	639	639	639	699	699	699	700
200	650	650	650	650	711	711	712	712
225	699	699	699	700	-	-	-	-
250	711	711	712	712	-	-	-	-

Center of Gravity

Table 23. Center of gravity (in) - 60 Hz

Unit Size (tons)	Packaged			Remote			Remote Evap		
	X	Y	Z	X	Y	Z	X	Y	Z
Aluminum Coils - Standard Efficiency									
140	88	45	35.5	85	45	37.25	39	30	25
155	88	45	35.5	85	45	37.25	39	30	25
170	88	45	35.5	85	45	37.25	39	30	25
185	106	44	35.5	103	44	39	53	30	25
200	106	45	35.5	107	45	39	53	30	25
225	124	45	35.5	121	45	41.5	53	30	25
250	124	45	35.5	121	45	41.5	53	30	25
275	176	42	35.5	-	-	-	-	-	-
300	199	42	35.5	-	-	-	-	-	-
350	205	42	35.5	-	-	-	-	-	-
400	234	44	35.5	-	-	-	-	-	-
450	266	44	35.5	-	-	-	-	-	-
500	274	44	35.5	-	-	-	-	-	-
Aluminum Coils - High Efficiency									
140	88	45	35.5	85	45	37.25	39	30	25
155	106	45	35.5	103	45	39	53	30	25
170	106	45	35.5	103	45	39	53	30	25
185	124	46	35.5	122	46	41.5	53	30	25
200	124	45	35.5	121	45	41.5	53	30	25
225	167	45	35.5	-	-	-	-	-	-
250	167	45	35.5	-	-	-	-	-	-
275	203	42	35.5	-	-	-	-	-	-
300	222	42	35.5	-	-	-	-	-	-
350	234	44	35.5	-	-	-	-	-	-
400	274	44	35.5	-	-	-	-	-	-
Aluminum Coils - Extra Efficiency									
140	106	45	35.5	-	-	-	-	-	-
155	124	46	35.5	-	-	-	-	-	-
170	124	45	35.5	-	-	-	-	-	-
185	167	45	35.5	-	-	-	-	-	-
200	167	45	35.5	-	-	-	-	-	-
250	203	42	35.5	-	-	-	-	-	-
275	222	42	35.5	-	-	-	-	-	-
300	234	44	35.5	-	-	-	-	-	-
350	274	44	35.5	-	-	-	-	-	-
Copper Coils - Standard Efficiency									
140	90	45	38	88	45	37.25	39	30	25
155	90	45	38	88	45	37.25	39	30	25
170	90	45	38	88	45	37.25	39	30	25
185	108	44	38	106	44	39	53	30	25
200	108	45	38	107	45	39	53	30	25
225	126	45	38	125	45	41.5	53	30	25
250	126	45	38	125	45	41.5	53	30	25
275	174	42	38	-	-	-	-	-	-
300	195	43	38	-	-	-	-	-	-
350	204	43	38	-	-	-	-	-	-
400	235	44	38	-	-	-	-	-	-
450	261	44	38	-	-	-	-	-	-
500	273	44	38	-	-	-	-	-	-

Table 23. Center of gravity (in) - 60 Hz (continued)

Unit Size (tons)	Packaged			Remote			Remote Evap		
	X	Y	Z	X	Y	Z	X	Y	Z
Copper Coils - High Efficiency									
140	90	45	38	88	45	37.25	39	30	25
155	108	45	38	106	45	39	53	30	25
170	108	45	38	106	45	39	53	30	25
185	126	46	38	125	46	41.5	53	30	25
200	126	45	38	124	45	41.5	53	30	25
225	170	45	38	-	-	-	-	-	-
250	170	45	38	-	-	-	-	-	-
275	201	42	38	-	-	-	-	-	-
300	219	42	38	-	-	-	-	-	-
350	234	44	38	-	-	-	-	-	-
400	273	44	38	-	-	-	-	-	-
Copper Coils - Extra Efficiency									
140	108	45	38	-	-	-	-	-	-
155	126	46	38	-	-	-	-	-	-
170	126	45	38	-	-	-	-	-	-
185	170	45	38	-	-	-	-	-	-
200	170	45	38	-	-	-	-	-	-
250	201	42	38	-	-	-	-	-	-
275	219	42	38	-	-	-	-	-	-
300	234	44	38	-	-	-	-	-	-
350	273	44	38	-	-	-	-	-	-

Table 24. Center of gravity (in) - packaged units - 50 Hz

Unit Size (tons)	Standard Efficiency			High Efficiency		
	X	Y	Z	X	Y	Z
Aluminum Coils						
120	-	-	-	88	45	35.5
130	-	-	-	88	45	35.5
140	88	45	35.5	88	45	35.5
155	88	44	35.5	106	44	35.5
170	89	45	35.5	106	45	35.5
185	106	45	35.5	124	45	35.5
200	106	45	35.5	124	45	35.5
250	182	41	35.5	177	41	35.5
275	172	41	35.5	202	42	35.5
300	201	42	35.5	222	42	35.5
350	235	44	35.5	234	44	35.5
375	229	44	35.5	266	44	35.5
400	234	44	35.5	274	44	35.5
Copper Coils						
120	-	-	-	90	45	38
130	-	-	-	90	45	38
140	90	45	38	90	45	38
155	90	44	38	108	44	38
170	90	45	38	108	45	38
185	108	45	38	126	45	38
200	108	45	38	126	45	38
250	183	42	38	174	42	38
275	171	42	38	200	42	38
300	197	42	38	220	42	38
350	235	44	38	235	44	38
375	227	44	38	261	44	38
400	235	44	38	273	44	38

Isolation and Sound Emission

The most effective form of isolation is to locate the unit away from any sound sensitive area. Structurally transmitted sound can be reduced by elastomeric vibration eliminators. Spring isolators are not recommended for non-seismically rated applications. Consult an acoustical engineer in critical sound applications.

For maximum isolation effect, isolate water lines and electrical conduit. Wall sleeves and rubber isolated piping hangers can be used to reduce the sound transmitted through water piping. To reduce the sound transmitted through electrical conduit, use flexible electrical conduit.

State and local codes on sound emissions should always be considered. Since the environment in which a sound source is located affects sound pressure, unit placement must be carefully evaluated. Sound power levels for Trane air-cooled Series R® chillers are available on request.

Figure 14. RTAC elastomeric isolator

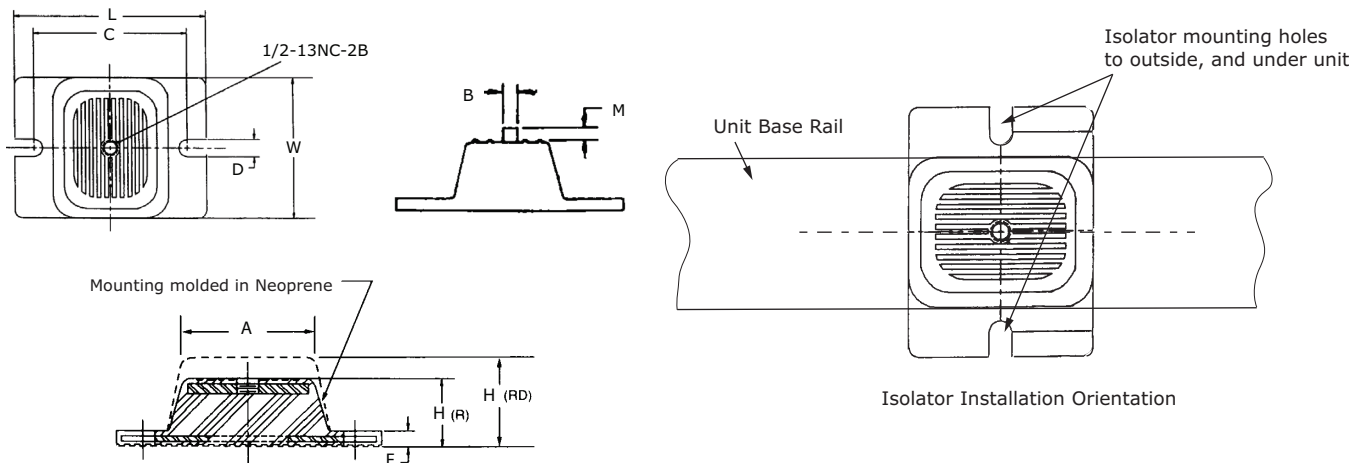

Table 25. RTAC elastomeric isolator details

EXT	Max Load Each (lbs)	Color	Maximum Deflection (in)	A	B	C	D	E	H	L	M	W	Type
61	1500	BROWN	0.50	3.00	0.50	5.00	0.56	0.38	2.75	6.25	1.60± .25	4.63	RDP-4
62	2250	RED											
63	3000	GREEN											
64	4000	GRAY											

See "Elastomeric Isolator Mounting Units without Seismic Rating," p. 37 for isolator selection, placement and point weights.

- Secure the isolators to the mounting surface using the mounting slots in the isolator base plate. Do not fully tighten the isolator mounting bolts at this time.

Important: For proper operation, isolator must be oriented as shown in Figure 14. Mounting holes must be to the outside, and under the unit.

Mounting and Leveling

For additional reduction of sound and vibration, install the optional elastomeric isolators, seismic isolation pads or seismic spring isolators. See "Unit Isolation," p. 34 for details.

Construct an isolated concrete pad for the unit or provide concrete footings at the unit mounting points. Mount the unit directly to the concrete pads or footings.

Level the unit using the base rail as a reference. The unit must be level within 1/4-in (6 mm) over the entire length and width. Use shims as necessary to level the unit.

Unit Isolation

Elastomeric Isolators (Optional for units without seismic rating)

See Figure 14 and Table 25 for description of elastomeric isolators (model number digit 33 = R or G).

- Align the mounting holes in the base of the unit with the threaded positioning pins on the top of the isolators.
- Lower the unit onto the isolators and secure the isolator to the unit with a nut.
- Level the unit carefully. Fully tighten the isolator mounting bolts.

Unit Isolation for Seismically Rated Units

Seismic Elastomeric Isolation Pads

Elastomeric pads are provided with an isolation washer and 3/4" free hole in the center of the plate. Isolation pads are shipped inside the unit control panel. See [Table 26](#) for pad specifications.

Table 26. Seismically rated elastomeric isolation pad

Model	Max Load	Dimension (in)		
		Length	Width	Height
B-36	2520	6	6	.625

See [Table 27](#) for quantity of isolation pads required and "Seismic Isolator Mounting," p. 44 or unit submittal for isolator placement dimensional information.

Table 27. Seismic elastomeric isolation pad quantities

Unit Size (tons)	Efficiency		
	Std	High	Extra
120	-	-	-
130	-	-	-
140	8	8	8
155	8	8	10
170	8	8	10
185	8	10	10
200	8	10	10
225	10	10	-
250	10	10	12
275	10	12	12
300	12	12	12
350	12	12	14
375	-	-	-
400	12	14	-
450	14	-	-
500	14	-	-

Set isolation pads on mounting surface, ensuring that all isolator centerlines match the submittal drawing.

Place unit on pads, and secure as shown in [Figure 15](#) using provided isolation washer and additional hardware obtained locally.

Figure 15. Seismic isolation pad — installed^(a)

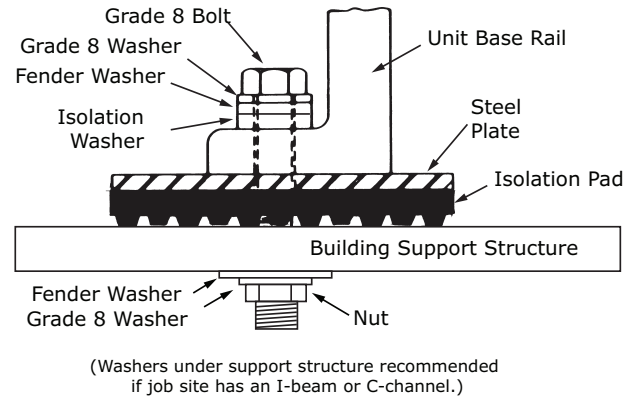

(a) Not to scale.

- With the exception of the isolation washer, hardware is not included.
- Recommended use of Grade 8 hardware
- Units have a tapered base rail that requires a tapered washer
- Support structure may vary
 - If job site has an I-beam or C-channel, a fender washer and grade 8 washer should be installed under the support structure.

NOTICE:

Replace Isolation Pads and Hardware after Seismic Event!

If unit experiences a seismic event, isolation pads and hardware must be replaced. Failure to replace isolation pads and hardware would compromise the installation and could result in equipment damage during future seismic events.

Seismic Spring Isolators

See "Seismic Isolator Mounting," p. 44 for mounting locations, isolator selection and point weights.

Seismically rated isolators are optional for IBC and OSHPD seismically rated units.

Isolators are identified by part number and color as shown in Table 28. For dimensions, see Figure 16.

Table 28. RTAC seismically rated isolator

Model	Rated Load (lbs)	Rated Deflection (in)	Spring Rate (lbs/in)	Color Code
MSSH-1E-2000	2000	1.11	1800	White
MSSH-1E-2575N	2575	1.11	2313	White/Dk Purple
MSSH-1E-2990N	2990	1.11	2682	White/Dk Green

Figure 16. MSSH seismically rated isolator

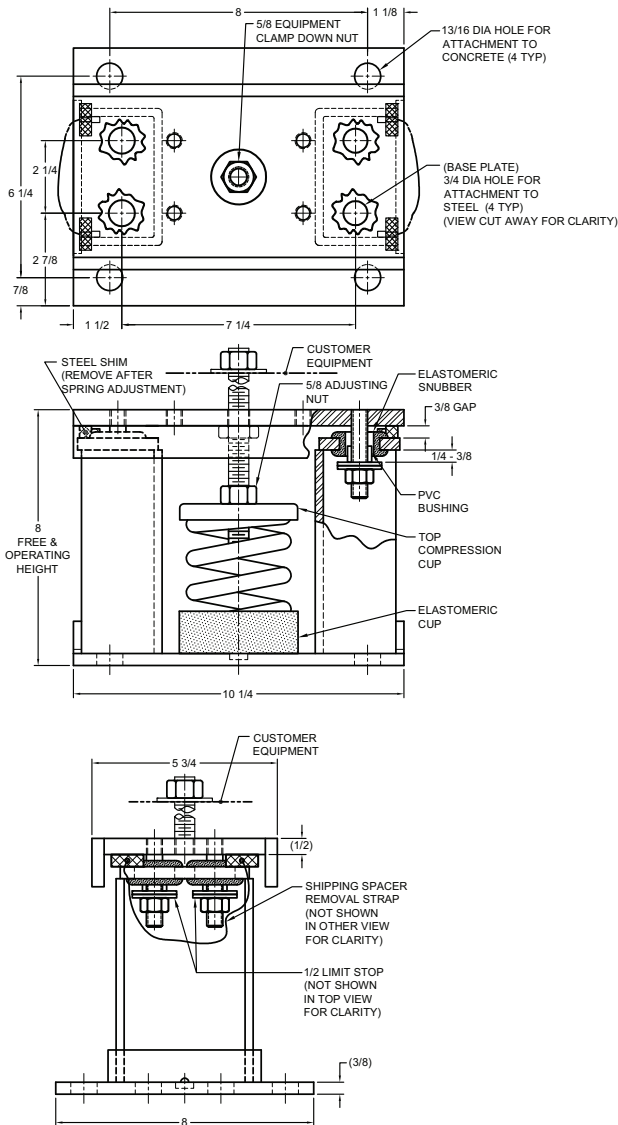

Install the optional seismically rated isolators at each mounting location specified in section "Seismic Isolator Mounting," p. 44.

Figure 17. MSSH Seismic isolator installation reference

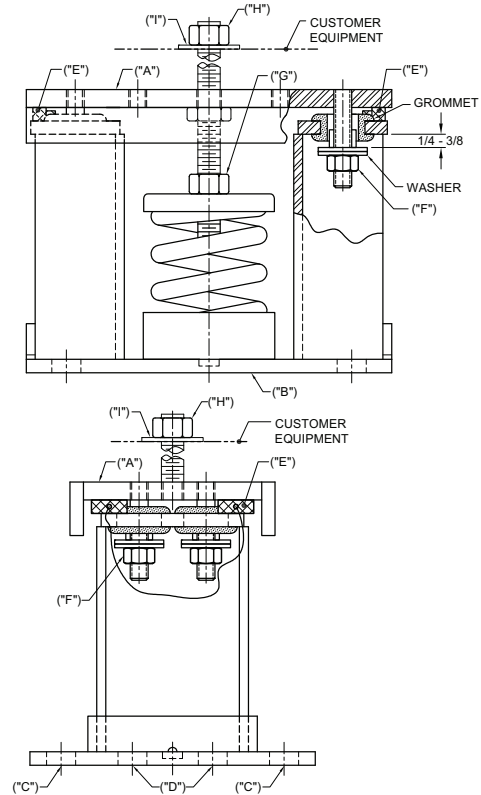

1. Set isolators on mounting surface, ensuring that all isolator centerlines match the submittal drawing. All isolator base plates (B) must be installed on a level surface. Shim or grout as required, leveling all isolator or base plates at the same elevation.
2. Anchor all isolators to the surface using thru holes (C) for concrete or (D) for steel as required. Welding to steel is permitted providing the weld achieves the required strength.
3. Remove clamp down nut (H) and washer (I). Isolators are shipped with (2) removable spacer shims (E) between the top plate and the housing.

Important: These shims **MUST** be in place when the equipment is positioned over the isolators.

4. With all shims (E) in place, place the equipment onto the top plate (A) of the isolators.
5. Bolt equipment securely to the isolators using washer (I) and nut (H).

Important: The following adjustment process can only begin after the equipment or machine is at its full operating weight.

6. Back off each of the (2) or (4) limit stop locknuts (F) per isolator 1/4-3/8"
7. Adjust each isolator in sequence by turning adjusting nut(s) (G) one full clockwise turn at a time. Repeat this procedure on all isolators, one at a time. Check the limit stop locknuts (F) periodically to ensure that clearance between the washer and rubber grommet is maintained. Stop adjustment of an isolator only when the top plate (A) has risen just above the shim (E).
8. Remove all spacer shims (E).
9. Fine adjust isolators to level equipment.
10. Adjust all limit stop locknuts (F) per isolator to obtain 3/8" gap. The limit stop nuts must be kept at this 3/8" gap to ensure uniform bolt loading during uplift.

Isolator Selection and Mounting Locations

Elastomeric Isolator Mounting Units without Seismic Rating

Figure 18. Mounting locations (without seismic rating)

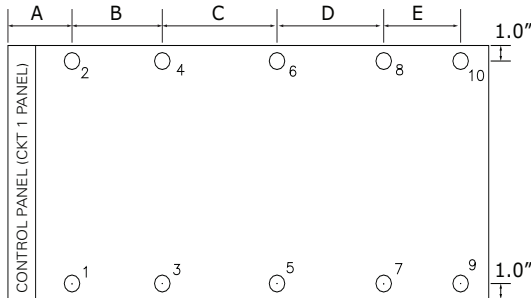

**Table 29. Mounting locations —
60 Hz units without seismic rating**

Size (tons)	Dimension (in)				
	A	B	C	D	E
Standard Efficiency					
140	15.13	46	53	53	-
155	15.13	46	53	53	-
170	15.13	46	53	53	-
185	15.08	48	76	76	-
200	15.08	48	76	76	-
225	15.08	39	69	64	64
250	15.08	39	69	64	64
275	18.70	76	90	90	75
300	18.70	71	90	100	140
350	18.70	71	90	100	140
400	18.70	139	103	67	128
450	18.70	128	127	127	127
500	18.70	128	127	127	127
High Efficiency					
140	15.13	46	53	53	-
155	15.13	48	76	76	-
170	15.13	48	76	76	-

**Table 29. Mounting locations —
60 Hz units without seismic rating (continued)**

Size (tons)	Dimension (in)				
	A	B	C	D	E
185	15.13	39	69	64	64
200	15.13	39	69	64	64
225	15.59	56	95	75	105
250	15.59	56	95	75	105
275	18.70	71	90	100	140
300	18.70	87	110	125	115
350	18.70	139	103	67	128
400	18.70	127	127	127	127
Extra Efficiency					
140	15.08	48	76	76	-
155	15.08	39	69	64	64
170	15.08	39	69	64	64
185	15.59	56	95	75	105
200	15.59	56	95	75	105
250	18.70	71	90	100	140
275	18.70	87	110	125	115
300	18.70	139	103	67	128
350	18.70	128	127	127	127

**Table 30. Mounting locations —
50 Hz units without seismic rating**

Size (tons)	Dimension (in)				
	A	B	C	D	E
Standard Efficiency					
140	15.13	46	53	53	-
155	15.13	46	53	53	-
170	15.13	46	53	53	-
185	15.08	48	76	76	-
200	15.08	48	76	76	-
250	18.70	76	90	90	75
275	18.70	76	90	90	75
300	18.70	71	90	100	140
375	18.70	139	103	67	128
350	18.70	139	103	67	128
400	18.70	139	103	67	128
High Efficiency					
120	15.13	46	53	53	-
130	15.13	46	53	53	-
140	15.13	46	53	53	-
155	15.13	48	76	76	-
170	15.13	48	76	76	-
185	15.13	39	69	64	64
200	15.13	39	69	64	64
250	15.59	76	90	90	75
275	15.59	71	90	100	140
300	18.70	87	110	125	115
350	18.70	139	103	67	128
375	18.70	128	127	127	127
400	18.70	128	127	127	127



Installation - Mechanical

Elastomeric Isolator Selection

Table 31. Elastomeric isolator selections - packaged units - 60 Hz

Size (tons)	Location									
	1	2	3	4	5	6	7	8	9	10
Standard Efficiency										
140	Red 62	Red 62	Red 62	Red 62	Red 62	Red 62	Red 62	Red 62	-	-
155	Red 62	Red 62	Red 62	Red 62	Red 62	Red 62	Red 62	Red 62	-	-
170	Red 62	Red 62	Red 62	Red 62	Red 62	Red 62	Red 62	Red 62	-	-
185	Red 62	Red 62	Red 62	Red 62	Red 62	Red 62	Red 62	Red 62	-	-
200	Red 62	Red 62	Red 62	Red 62	Red 62	Red 62	Red 62	Red 62	-	-
225	Red 62	Red 62	Red 62	Red 62	Red 62	Red 62	Red 62	Red 62	Red 62	Red 62
250	Red 62	Red 62	Red 62	Red 62	Red 62	Red 62	Red 62	Red 62	Red 62	Red 62
275	Gray 64	Gray 64	Gray 64	Gray 64	Gray 64	Gray 64	Gray 64	Gray 64	Gray 64	Gray 64
300	Gray 64	Gray 64	Gray 64	Gray 64	Gray 64	Gray 64	Gray 64	Gray 64	Gray 64	Gray 64
350	Gray 64	Gray 64	Gray 64	Gray 64	Gray 64	Gray 64	Gray 64	Gray 64	Gray 64	Gray 64
400	Gray 64	Gray 64	Gray 64	Gray 64	Gray 64	Gray 64	Gray 64	Gray 64	Gray 64	Gray 64
450	Gray 64	Gray 64	Gray 64	Gray 64	Gray 64	Gray 64	Gray 64	Gray 64	Gray 64	Gray 64
500	Gray 64	Gray 64	Gray 64	Gray 64	Gray 64	Gray 64	Gray 64	Gray 64	Gray 64	Gray 64
High Efficiency										
140	Red 62	Red 62	Red 62	Red 62	Red 62	Red 62	Red 62	Red 62	-	-
155	Red 62	Red 62	Red 62	Red 62	Red 62	Red 62	Red 62	Red 62	-	-
170	Red 62	Red 62	Red 62	Red 62	Red 62	Red 62	Red 62	Red 62	-	-
185	Red 62	Red 62	Red 62	Red 62	Red 62	Red 62	Red 62	Red 62	Red 62	Red 62
200	Red 62	Red 62	Red 62	Red 62	Red 62	Red 62	Red 62	Red 62	Red 62	Red 62
225	Red 62	Red 62	Red 62	Red 62	Red 62	Red 62	Red 62	Red 62	Red 62	Red 62
250	Red 62	Red 62	Red 62	Red 62	Red 62	Red 62	Red 62	Red 62	Red 62	Red 62
275	Gray 64	Gray 64	Gray 64	Gray 64	Gray 64	Gray 64	Gray 64	Gray 64	Gray 64	Gray 64
300	Gray 64	Gray 64	Gray 64	Gray 64	Gray 64	Gray 64	Gray 64	Gray 64	Gray 64	Gray 64
350	Gray 64	Gray 64	Gray 64	Gray 64	Gray 64	Gray 64	Gray 64	Gray 64	Gray 64	Gray 64
400	Gray 64	Gray 64	Gray 64	Gray 64	Gray 64	Gray 64	Gray 64	Gray 64	Gray 64	Gray 64
Extra Efficiency										
140	Red 62	Red 62	Red 62	Red 62	Red 62	Red 62	Red 62	Red 62	-	-
155	Red 62	Red 62	Red 62	Red 62	Red 62	Red 62	Red 62	Red 62	Red 62	Red 62
170	Red 62	Red 62	Red 62	Red 62	Red 62	Red 62	Red 62	Red 62	Red 62	Red 62
185	Red 62	Red 62	Red 62	Red 62	Red 62	Red 62	Red 62	Red 62	Red 62	Red 62
200	Red 62	Red 62	Red 62	Red 62	Red 62	Red 62	Red 62	Red 62	Red 62	Red 62
250	Gray 64	Gray 64	Gray 64	Gray 64	Gray 64	Gray 64	Gray 64	Gray 64	Gray 64	Gray 64
275	Gray 64	Gray 64	Gray 64	Gray 64	Gray 64	Gray 64	Gray 64	Gray 64	Gray 64	Gray 64
300	Gray 64	Gray 64	Gray 64	Gray 64	Gray 64	Gray 64	Gray 64	Gray 64	Gray 64	Gray 64
350	Gray 64	Gray 64	Gray 64	Gray 64	Gray 64	Gray 64	Gray 64	Gray 64	Gray 64	Gray 64

Table 32. Elastomeric isolator selections - packaged units - 50 Hz

Size (tons)	Location									
	1	2	3	4	5	6	7	8	9	10
Standard Efficiency										
140	Red 62	Red 62	Red 62	Red 62	Red 62	Red 62	Red 62	Red 62	-	-
155	Red 62	Red 62	Red 62	Red 62	Red 62	Red 62	Red 62	Red 62	-	-
170	Red 62	Red 62	Red 62	Red 62	Red 62	Red 62	Red 62	Red 62	-	-
185	Red 62	Red 62	Red 62	Red 62	Red 62	Red 62	Red 62	Red 62	-	-
200	Red 62	Red 62	Red 62	Red 62	Red 62	Red 62	Red 62	Red 62	-	-
250	Gray 64	Gray 64	Gray 64	Gray 64	Gray 64	Gray 64	Gray 64	Gray 64	Gray 64	Gray 64
275	Gray 64	Gray 64	Gray 64	Gray 64	Gray 64	Gray 64	Gray 64	Gray 64	Gray 64	Gray 64
300	Gray 64	Gray 64	Gray 64	Gray 64	Gray 64	Gray 64	Gray 64	Gray 64	Gray 64	Gray 64
350	Gray 64	Gray 64	Gray 64	Gray 64	Gray 64	Gray 64	Gray 64	Gray 64	Gray 64	Gray 64
400	Gray 64	Gray 64	Gray 64	Gray 64	Gray 64	Gray 64	Gray 64	Gray 64	Gray 64	Gray 64
High Efficiency										
120	Red 62	Red 62	Red 62	Red 62	Red 62	Red 62	Red 62	Red 62	-	-
130	Red 62	Red 62	Red 62	Red 62	Red 62	Red 62	Red 62	Red 62	-	-
140	Red 62	Red 62	Red 62	Red 62	Red 62	Red 62	Red 62	Red 62	-	-
155	Red 62	Red 62	Red 62	Red 62	Red 62	Red 62	Red 62	Red 62	-	-
170	Red 62	Red 62	Red 62	Red 62	Red 62	Red 62	Red 62	Red 62	-	-
185	Red 62	Red 62	Red 62	Red 62	Red 62	Red 62	Red 62	Red 62	Red 62	Red 62
200	Red 62	Red 62	Red 62	Red 62	Red 62	Red 62	Red 62	Red 62	Red 62	Red 62
250	Gray 64	Gray 64	Gray 64	Gray 64	Gray 64	Gray 64	Gray 64	Gray 64	Gray 64	Gray 64
275	Gray 64	Gray 64	Gray 64	Gray 64	Gray 64	Gray 64	Gray 64	Gray 64	Gray 64	Gray 64
300	Gray 64	Gray 64	Gray 64	Gray 64	Gray 64	Gray 64	Gray 64	Gray 64	Gray 64	Gray 64
350	Gray 64	Gray 64	Gray 64	Gray 64	Gray 64	Gray 64	Gray 64	Gray 64	Gray 64	Gray 64
400	Gray 64	Gray 64	Gray 64	Gray 64	Gray 64	Gray 64	Gray 64	Gray 64	Gray 64	Gray 64

Table 33. Elastomeric isolator selections - remote units - 60 Hz

Size (tons)	Location									
	1	2	3	4	5	6	7	8	9	10
Standard Efficiency										
140	Brown 61	Brown 61	Brown 61	Brown 61	Brown 61	Brown 61	Brown 61	Brown 61	-	-
155	Brown 61	Brown 61	Brown 61	Brown 61	Brown 61	Brown 61	Brown 61	Brown 61	-	-
170	Brown 61	Brown 61	Brown 61	Brown 61	Brown 61	Brown 61	Brown 61	Brown 61	-	-
185	Brown 61	Brown 61	Brown 61	Brown 61	Brown 61	Brown 61	Brown 61	Brown 61	-	-
200	Brown 61	Brown 61	Brown 61	Brown 61	Brown 61	Brown 61	Brown 61	Brown 61	-	-
225	Brown 61	Brown 61	Brown 61	Brown 61	Brown 61	Brown 61	Brown 61	Brown 61	Brown 61	Brown 61
250	Brown 61	Brown 61	Brown 61	Brown 61	Brown 61	Brown 61	Brown 61	Brown 61	Brown 61	Brown 61
High Efficiency										
140	Brown 61	Brown 61	Brown 61	Brown 61	Brown 61	Brown 61	Brown 61	Brown 61	-	-
155	Brown 61	Brown 61	Brown 61	Brown 61	Brown 61	Brown 61	Brown 61	Brown 61	-	-
170	Brown 61	Brown 61	Brown 61	Brown 61	Brown 61	Brown 61	Brown 61	Brown 61	-	-
185	Brown 61	Brown 61	Brown 61	Brown 61	Brown 61	Brown 61	Brown 61	Brown 61	Brown 61	Brown 61
200	Brown 61	Brown 61	Brown 61	Brown 61	Brown 61	Brown 61	Brown 61	Brown 61	Brown 61	Brown 61



Installation - Mechanical

Point Weights (Units without Seismic Rating)

See Table 34, p. 40 through Table 36, p. 43 for point weights of units that are NOT seismically rated.

See Table 40, p. 46 for seismically rated units (unit model number digit 13 = S or E).

Table 34. Point weights (lbs) - packaged units - 60 Hz- units not seismically rated

Size (tons)	Isolator Location									
	W1	W2	W3	W4	W5	W6	W7	W8	W9	W10
Aluminum Coils - Standard Efficiency										
140	1402	1450	1383	1430	1361	1408	1333	1379	-	-
155	1402	1450	1383	1430	1361	1408	1333	1379	-	-
170	1461	1450	1383	1430	1361	1408	1339	1386	-	-
185	1657	1673	1734	1638	1564	1584	1519	1530	-	-
200	1674	1733	1646	1701	1604	1658	1561	1616	-	-
225	1521	1571	1503	1554	1472	1522	1443	1494	1413	1473
250	1539	1601	1522	1584	1493	1522	1465	1527	1438	1500
275	1925	2188	1887	2148	1870	2082	1787	2062	1750	1986
300	1936	2173	1974	2198	1994	2230	2029	2266	2080	2334
350	1907	2144	1977	2213	2065	2301	2163	2399	2300	2536
400	2744	2758	2667	2646	2584	2564	2531	2510	2428	2422
450	2812	2774	2791	2753	2770	2733	2750	2712	2729	2569
500	2777	2719	2787	2744	2812	2768	2836	2792	2860	2817
Aluminum Coils - High Efficiency										
140	1402	1450	1383	1430	1361	1408	1339	1387	-	-
155	1588	1648	1565	1609	1505	1558	1465	1507	-	-
170	1657	1652	1565	1622	1515	1579	1465	1530	-	-
185	1419	1523	1405	1510	1381	1496	1358	1466	1335	1400
200	1497	1552	1479	1539	1446	1496	1417	1466	1389	1440
225	1661	1686	1649	1674	1629	1654	1613	1639	1591	1617
250	1661	1686	1649	1674	1629	1654	1613	1639	1591	1617
275	1829	2070	1891	2134	1960	2201	2093	2282	2193	2395
300	2147	2392	2120	2391	2087	2357	2049	2319	2014	2284
350	2647	2629	2535	2517	2452	2434	2512	2380	2294	2300
400	2744	2705	2773	2729	2797	2754	2822	2778	2846	2802
Aluminum Coils - Extra Efficiency										
140	1657	1652	1565	1622	1515	1579	1465	1530	-	-
155	1419	1523	1405	1510	1381	1496	1358	1466	1335	1400
170	1497	1552	1479	1539	1446	1496	1417	1466	1389	1440
185	1661	1686	1649	1674	1629	1654	1613	1639	1591	1617
200	1661	1686	1649	1674	1629	1654	1613	1639	1591	1617
250	1829	2070	1891	2134	1960	2201	2093	2282	2193	2395
275	2147	2392	2120	2391	2087	2357	2049	2319	2014	2284
300	2647	2629	2535	2517	2452	2434	2512	2380	2294	2300
350	2744	2705	2773	2729	2797	2754	2822	2778	2846	2802

Table 34. Point weights (lbs) - packaged units - 60 Hz- units not seismically rated (continued)

Size (tons)	Isolator Location									
	W1	W2	W3	W4	W5	W6	W7	W8	W9	W10
Copper Coils - Standard Efficiency										
140	1658	1720	1675	1737	1695	1757	1715	1777	-	-
155	1658	1720	1675	1737	1695	1757	1715	1777	-	-
170	1658	1720	1675	1737	1695	1757	1715	1776	-	-
185	2025	2061	2012	2052	1997	2098	1984	2024	-	-
200	2042	2121	2040	2114	2038	2129	2036	2110	-	-
225	1868	1954	1865	1945	1861	1951	1859	1049	1857	1947
250	1891	1961	1890	1960	1887	1957	1885	1956	1883	1953
275	2505	2768	2458	2700	2358	2589	2215	2501	2130	2384
300	2550	2787	2458	2786	2547	2784	2545	2782	2543	2798
350	2467	2704	2548	2785	2651	2888	2765	3003	2946	3163
400	3474	3498	3372	3350	3272	3207	3207	3184	3082	3077
450	3576	3602	3465	3468	3332	3199	3199	3202	3066	3069
500	3552	3513	3575	3536	3597	3620	3620	3580	3642	3552
Copper Coils - High Efficiency										
140	1658	1720	1675	1737	1695	1757	1715	1777	-	-
155	1956	2029	1958	2022	1949	2011	1928	2001	-	-
170	1965	2040	1958	2035	1949	2098	1939	2014	-	-
185	1788	1914	1792	1916	1796	1951	1800	1924	1804	1928
200	1868	1928	1865	1936	1861	1932	1859	1928	1853	1928
225	2077	2125	2090	2135	2105	2152	2118	2166	2137	2185
250	2077	2125	2090	2135	2105	2152	2118	2166	2137	2185
275	2410	2652	2458	2700	2519	2761	2587	2828	2720	2923
300	2825	3097	2766	3037	2690	2962	2605	2876	2526	2798
350	3377	3357	3241	3221	3139	3074	3074	3054	2948	2946
400	3531	3498	3561	3521	3583	3606	3606	3566	3628	3588
Copper Coils - Extra Efficiency										
140	1965	2040	1958	2035	1949	2098	1939	2014	-	-
155	1788	1914	1792	1916	1796	1951	1800	1924	1804	1928
170	1868	1928	1865	1936	1861	1932	1859	1928	1853	1928
185	2077	2125	2090	2135	2105	2152	2118	2166	2137	2185
200	2077	2125	2090	2135	2105	2152	2118	2166	2137	2185
250	2410	2652	2458	2700	2519	2761	2587	2828	2720	2923
275	2825	3097	2766	3037	2690	2962	2605	2876	2526	2798
300	3377	3357	3241	3221	3139	3074	3074	3054	2948	2946
350	3531	3498	3561	3521	3583	3606	3606	3566	3628	3588



Installation - Mechanical

Table 35. Point weights (lbs) - packaged units - 50 Hz

Size (tons)	Isolator Location									
	W1	W2	W3	W4	W5	W6	W7	W8	W9	W10
Aluminum Coils - Standard Efficiency										
140	1402	1450	1383	1430	1361	1408	1333	1379	-	-
155	1461	1457	1444	1435	1414	1411	1389	1386	-	-
170	1402	1503	1444	1491	1431	1478	1418	1465	-	-
185	1674	1733	1646	1699	1586	1645	1532	1596	-	-
200	1674	1742	1662	1716	1621	1675	1580	1634	-	-
250	1936	1642	1963	2356	1997	1703	2030	1736	2059	1764
275	2059	2353	1973	2266	1870	2201	1787	2062	1683	1986
300	1936	2104	1890	2198	1994	2196	2029	2266	2080	2334
350	2539	2520	2451	2421	2368	2349	2320	2301	2230	2300
375	2437	2386	2491	2440	2519	2678	2562	2511	2620	2569
400	2744	2758	2667	2646	2584	2564	2531	2510	2428	2422
Aluminum Coils - High Efficiency										
120	1402	1450	1383	1430	1361	1408	1333	1379	-	-
130	1402	1450	1383	1430	1361	1408	1333	1379	-	-
140	1402	1450	1383	1430	1361	1408	1339	1387	-	-
155	1657	1648	1617	1622	1585	1579	1541	1537	-	-
170	1597	1712	1629	1684	1586	1645	1541	1596	-	-
185	1468	1552	1455	1539	1446	1522	1417	1494	1389	1472
200	1521	1571	1503	1554	1472	1522	1443	1494	1414	1473
250	1926	2187	1888	2685	1833	2100	1786	2063	2000	2015
275	1907	2174	1973	2209	2022	2273	2093	2244	2193	2444
300	2147	2417	2120	2391	2087	2357	2049	2319	2014	2284
350	2392	2340	2522	2470	2591	2538	2695	2643	2837	2784
375	2755	2718	2735	2698	2715	2678	2695	2658	2674	2637
400	2744	2705	2773	2729	2797	2754	2822	2779	2846	2802
Copper Coils - Standard Efficiency										
140	1658	1720	1675	1737	1695	1757	1715	1777	-	-
155	1717	1728	1737	1742	1748	1750	1765	1775	-	-
170	1717	1774	1737	1798	1765	1827	1893	1855	-	-
185	2042	2121	2034	2112	2020	2038	2006	2090	-	-
200	2056	2130	2055	2130	2055	2112	2054	2129	-	-
250	2078	2332	2089	1669	2118	2385	2146	2413	2170	2437
275	2638	2933	2529	2805	2358	2653	2215	2501	2079	2384
300	2462	2718	2477	2732	2495	2784	2545	2782	2543	2798
350	3158	3137	3039	3018	2951	2894	2894	2873	2784	2779
375	3576	3579	3291	3255	3083	2948	2948	2912	2689	2690
400	3538	3498	3372	3350	3272	3207	3207	3184	3082	3077
Copper Coils - Standard Efficiency										
120	1658	1720	1675	1737	1695	1757	1715	1777	-	-
130	1658	1720	1675	1737	1695	1757	1715	1777	-	-
140	1658	1720	1675	1737	1695	1757	1715	1777	-	-
155	2025	2040	2012	2035	2009	2033	2007	2031	-	-
170	2025	2100	3034	2098	2020	2038	2016	2090	-	-
185	1839	1954	1842	1945	1846	1920	1859	1956	1857	1961
200	1891	1961	1890	1960	1887	1957	1885	1956	1883	1953
250	2506	2767	2418	2134	2321	2588	2224	2491	2170	2437
275	2488	2740	2529	2805	2581	2833	2639	2828	2720	2972
300	2825	3097	2766	3037	2690	2962	2605	2876	2526	2798
350	3000	2934	3184	3118	3281	3214	3429	3362	3628	3562
375	3576	3579	3442	3445	3309	3176	3176	3179	3043	3046
400	3445	3396	3516	3467	3587	3538	3658	3609	3628	3681

Table 36. Point weights (lbs) - condensing units - 60 Hz

Size (tons)	Isolator Location									
	1	2	3	4	5	6	7	8	9	10
Aluminum Coils - Standard Efficiency										
140	1150	1183	1095	1128	1032	1065	969	1002	-	-
155	1150	1183	1095	1128	1032	1065	969	1002	-	-
170	1150	1183	1095	1128	1032	1065	969	1002	-	-
185	1381	1384	1325	1331	1241	1246	1156	1162	-	-
200	1397	1437	1351	1391	1279	1318	1206	1246	-	-
225	1251	1307	1222	1279	1172	1229	1126	1190	1081	1140
250	1274	1312	1246	1283	1196	1233	1149	1190	1103	1140
Aluminum Coils - High Efficiency										
140	1150	1183	1095	1128	1032	1065	969	1002	-	-
155	1321	1361	1270	1301	1190	1230	1109	1149	-	-
170	1321	1361	1270	1314	1190	1230	1109	1149	-	-
185	1175	1267	1151	1242	1107	1199	1067	1159	1027	1118
200	1251	1295	1222	1259	1172	1207	1122	1159	1081	1118
Copper Coils - Standard Efficiency										
140	1406	1454	1388	1435	1366	1414	1345	1392	-	-
155	1406	1454	1388	1435	1366	1414	1345	1392	-	-
170	1406	1454	1388	1435	1366	1414	1345	1392	-	-
185	1749	1772	1718	1744	1675	1700	1631	1656	-	-
200	1768	1825	1745	1805	1713	1772	1680	1740	-	-
225	1622	1697	1608	1686	1587	1665	1568	1645	1549	1625
250	1644	1702	1633	1690	1611	1668	1591	1648	1571	1628
Copper Coils - High Efficiency										
140	1406	1454	1388	1435	1366	1414	1345	1392	-	-
155	1689	1749	1664	1714	1624	1673	1583	1644	-	-
170	1689	1749	1664	1727	1624	1695	1583	1644	-	-
185	1546	1657	1537	1649	1523	1634	1509	1621	1495	1607
200	1622	1686	1608	1666	1587	1642	1568	1621	1549	1599

Seismic Isolator Mounting

Figure 19. Mounting locations — seismic spring isolators or seismic elastomeric pads

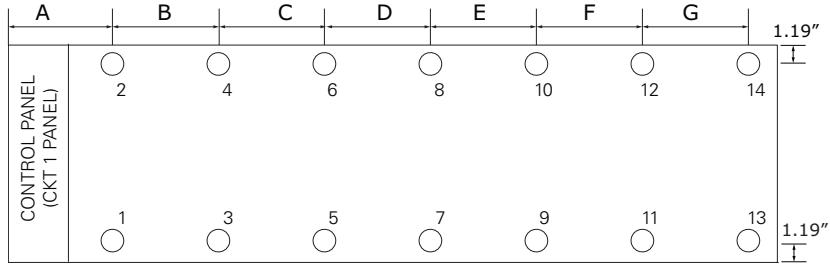

Table 37. Mounting locations — 60 Hz units with seismic rating

Size (tons)	Dimension (in)						
	A	B	C	D	E	F	G
Standard Efficiency							
140	17	46	53	53	-	-	-
155	17	46	53	53	-	-	-
170	17	46	53	53	-	-	-
185	17	48	76	76	-	-	-
200	17	48	76	76	-	-	-
225	17	39	69	64	64	-	-
250	17	39	69	64	64	-	-
275	17	76	90	90	75	-	-
300	17	80.25	80.25	80.25	80.25	80.25	-
350	17	80.25	80.25	80.25	80.25	80.25	-
400	17	87.5	87.5	87.5	87.5	87.5	-
450	17	84.85	84.85	84.85	84.85	92.75	78
500	17	84.85	84.85	84.85	84.85	92.75	78
High Efficiency							
140	17	46	53	53	-	-	-
155	17	48	76	76	-	-	-
170	17	48	76	76	-	-	-
185	17	39	69	64	64	-	-
200	17	39	69	64	64	-	-
225	17	56	95	75	105	-	-
250	17	56	95	75	105	-	-
275	17	80.25	80.25	80.25	80.25	80.25	-
300	17	87.5	87.5	87.5	87.5	87.5	-
350	17	87.5	87.5	87.5	87.5	87.5	-
400	17	84.85	84.85	84.85	84.85	92.75	78
Extra Efficiency							
140	17	48	76	76	-	-	-
155	17	39	69	64	64	-	-
170	17	39	69	64	64	-	-
185	17	56	95	75	105	-	-
200	17	56	95	75	105	-	-
250	17	80.25	80.25	80.25	80.25	80.25	-
275	17	87.5	87.5	87.5	87.5	87.5	-
300	17	87.5	87.5	87.5	87.5	87.5	-
350	17	84.85	84.85	84.85	84.85	92.75	78

Table 38. Mounting locations — 50 Hz units with seismic rating

Size (tons)	Dimension (in)						
	A	B	C	D	E	F	G
Standard Efficiency							
140	17	46	53	53	-	-	-
155	17	46	53	53	-	-	-
170	17	46	53	53	-	-	-
185	17	48	76	76	-	-	-
200	17	48	76	76	-	-	-
250	17	76	90	90	75	-	-
275	17	76	90	90	75	-	-
300	17	80.25	80.25	80.25	80.25	80.25	-
375	17	87.5	87.5	87.5	87.5	87.5	-
350	17	87.5	87.5	87.5	87.5	87.5	-
400	17	87.5	87.5	87.5	87.5	87.5	-
High Efficiency							
120	17	46	53	53	-	-	-
130	17	46	53	53	-	-	-
140	17	46	53	53	-	-	-
155	17	48	76	76	-	-	-
170	17	48	76	76	-	-	-
185	17	39	69	64	64	-	-
200	17	39	69	64	64	-	-
250	17	76	90	90	75	-	-
275	17	80.25	80.25	80.25	80.25	80.25	-
300	17	87.5	87.5	87.5	87.5	87.5	-
350	17	87.5	87.5	87.5	87.5	87.5	-
375	17	84.85	84.85	84.85	84.85	92.75	78
400	17	84.85	84.85	84.85	84.85	92.75	78

Seismic Spring Isolator Selection
Table 39. Seismic spring isolator selections (MSSH-1E-xxxx)

Size (tons)	Location													
	1	2	3	4	5	6	7	8	9	10	11	12	13	14
Standard Efficiency														
140	2000	2000	2000	2000	2000	2000	2000	2000	-	-	-	-	-	-
155	2000	2000	2000	2000	2000	2000	2000	2000	-	-	-	-	-	-
170	2000	2000	2000	2000	2000	2000	2000	2000	-	-	-	-	-	-
185	2575N	2575N	2575N	2575N	2575N	2575N	2575N	2575N	-	-	-	-	-	-
200	2575N	2575N	2575N	2575N	2575N	2575N	2575N	2575N	-	-	-	-	-	-
225	2000	2000	2000	2000	2000	2000	2000	2000	2000	2000	-	-	-	-
250	2575N	2575N	2575N	2575N	2575N	2575N	2575N	2575N	2575N	2575N	-	-	-	-
275	2990N	2990N	2990N	2990N	2575N	2575N	2575N	2575N	2575N	2575N	-	-	-	-
300	2990N	2990N	2990N	2990N	2575N	2575N	2575N	2575N	2000	2000	2000	2000	-	-
350	2990N	2990N	2990N	2990N	2575N	2575N	2575N	2575N	2575N	2575N	2000	2000	-	-
400	2990N	2990N	2990N	2990N	2990N	2990N	2990N	2990N	2990N	2990N	2990N	2990N	-	-
450	2990N	2990N	2990N	2990N	2990N	2990N	2990N	2990N	2990N	2990N	2990N	2990N	2990N	2990N
500	2990N	2990N	2990N	2990N	2990N	2990N	2990N	2990N	2990N	2990N	2990N	2990N	2990N	2990N
High Efficiency														
140	2000	2000	2000	2000	2000	2000	2000	2000	-	-	-	-	-	-
155	2000	2000	2000	2000	2000	2000	2000	2000	-	-	-	-	-	-
170	2000	2000	2000	2000	2000	2000	2000	2000	-	-	-	-	-	-
185	2000	2000	2000	2000	2000	2000	2000	2000	2000	2000	-	-	-	-
200	2000	2000	2000	2000	2000	2000	2000	2000	2000	2000	-	-	-	-
225	2575N	2575N	2575N	2575N	2575N	2575N	2000	2000	2000	2000	-	-	-	-
250	2575N	2575N	2575N	2575N	2575N	2575N	2000	2000	2000	2000	-	-	-	-
275	2990N	2990N	2990N	2990N	2575N	2575N	2575N	2575N	2000	2000	2000	2000	-	-
300	2575N	2575N	2575N	2575N	2575N	2575N	2575N	2575N	2575N	2575N	2575N	2575N	-	-
350	2990N	2990N	2990N	2990N	2990N	2990N	2990N	2990N	2990N	2990N	2990N	2990N	-	-
400	2990N	2990N	2990N	2990N	2990N	2990N	2990N	2990N	2990N	2990N	2990N	2990N	2990N	2990N
Extra Efficiency														
140	2000	2000	2000	2000	2000	2000	2000	2000	-	-	-	-	-	-
155	2000	2000	2000	2000	2000	2000	2000	2000	2000	2000	-	-	-	-
170	2000	2000	2000	2000	2000	2000	2000	2000	2000	2000	-	-	-	-
185	2575N	2575N	2575N	2575N	2575N	2575N	2000	2000	2000	2000	-	-	-	-
200	2575N	2575N	2575N	2575N	2575N	2575N	2000	2000	2000	2000	-	-	-	-
250	2990N	2990N	2990N	2990N	2575N	2575N	2575N	2575N	2000	2000	2000	2000	-	-
275	2575N	2575N	2575N	2575N	2575N	2575N	2575N	2575N	2575N	2575N	2575N	2575N	-	-
300	2990N	2990N	2990N	2990N	2990N	2990N	2990N	2990N	2990N	2990N	2990N	2990N	-	-
350	2990N	2990N	2990N	2990N	2990N	2990N	2990N	2990N	2990N	2990N	2990N	2990N	2990N	2990N



Installation - Mechanical

Point Weights (Units with Seismic Rating)

Table 40. Point weights (lbs) - seismically rated units

Size (tons)	Isolator Location													
	W1	W2	W3	W4	W5	W6	W7	W8	W9	W10	W11	W12	W13	W14
Aluminum Coils - Standard Efficiency														
140	1465	1515	1445	1494	1422	1471	1393	1441	-	-	-	-	-	-
155	1472	1522	1452	1501	1429	1478	1400	1448	-	-	-	-	-	-
170	1534	1523	1452	1502	1429	1478	1406	1455	-	-	-	-	-	-
185	1740	1757	1821	1720	1642	1663	1595	1607	-	-	-	-	-	-
200	1758	1820	1728	1786	1684	1741	1639	1697	-	-	-	-	-	-
225	1597	1650	1578	1632	1546	1598	1515	1569	1484	1547	-	-	-	-
250	1616	1681	1598	1663	1568	1598	1538	1603	1510	1575	-	-	-	-
275	2360	2250	2251	2140	2122	2011	1993	1882	1885	1774	-	-	-	-
300	2387	2287	2220	2120	2008	1909	1772	1673	1607	1508	1442	1343	-	-
350	2357	2254	2224	2122	2058	1954	1871	1768	1741	1638	1611	1507	-	-
400	2322	2410	2280	2368	2239	2327	2197	2286	2156	2245	2115	2203	-	-
450	2143	2223	2111	2191	2079	2159	2015	2095	1951	2031	1918	1999	1887	1967
500	1738	1821	1814	1896	1937	2019	2050	2132	2163	2245	2276	2358	2389	2471
Aluminum Coils - High Efficiency														
140	1471	1522	1451	1501	1428	1478	1405	1455	-	-	-	-	-	-
155	1667	1730	1643	1689	1580	1636	1538	1582	-	-	-	-	-	-
170	1740	1735	1643	1703	1591	1658	1538	1606	-	-	-	-	-	-
185	1490	1599	1475	1586	1450	1571	1426	1539	1402	1470	-	-	-	-
200	1572	1630	1553	1616	1518	1571	1488	1539	1458	1512	-	-	-	-
225	1701	1846	1683	1828	1652	1796	1627	1771	1592	1737	-	-	-	-
250	1701	1846	1683	1828	1652	1796	1627	1772	1592	1737	-	-	-	-
275	2293	2193	2153	2054	1976	1877	1780	1680	1642	1543	1504	1406	-	-
300	2308	2204	2181	2077	2055	1950	1927	1824	1801	1697	1674	1571	-	-
350	2218	2302	2179	2263	2139	2223	2100	2184	2060	2144	2021	2105	-	-
400	2043	2125	2043	2124	2043	2123	2041	2122	2039	2121	2038	2120	2037	2119
Aluminum Coils - Extra Efficiency														
140	1736	1731	1640	1699	1587	1654	1535	1603	-	-	-	-	-	-
155	1491	1601	1477	1587	1451	1572	1427	1541	1403	1471	-	-	-	-
170	1569	1627	1551	1613	1516	1568	1486	1537	1456	1510	-	-	-	-
185	1701	1846	1683	1828	1651	1796	1627	1772	1592	1737	-	-	-	-
200	1697	1850	1679	1831	1648	1800	1623	1776	1589	1741	-	-	-	-
250	2292	2194	2153	2054	1976	1877	1779	1681	1642	1543	1504	1405	-	-
275	2307	2203	2181	2077	2055	1951	1928	1824	1801	1697	1674	1570	-	-
300	2218	2302	2178	2262	2139	2223	2099	2184	2059	2145	2021	2105	-	-
350	2044	2125	2043	2124	2042	2124	2041	2122	2039	2120	2038	2119	2037	2118

Drainage

Provide large capacity drain for use during shutdown or repair. Evaporator is provided with drain connection. All local and national codes apply. Vent on top of evaporator waterbox prevents vacuum by allowing air into evaporator for complete drainage.

Evaporator Water Piping

RTAC units are available with 2- or 3-pass evaporator configurations.

Figure 20. Evaporator pass configurations - 2 compressor units

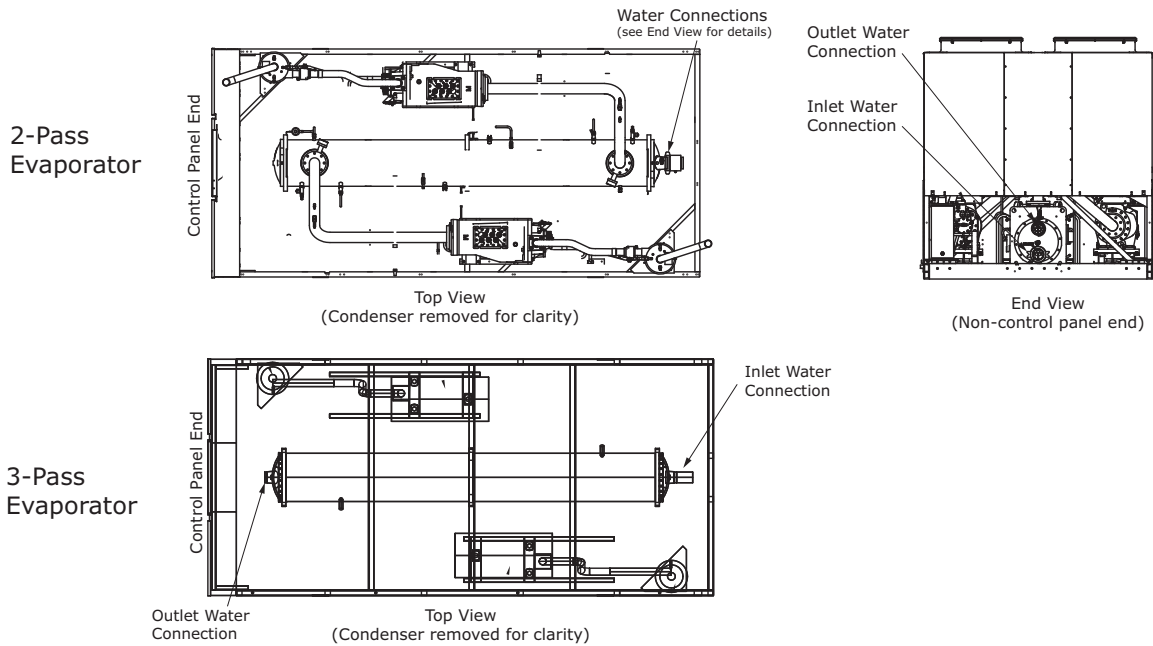
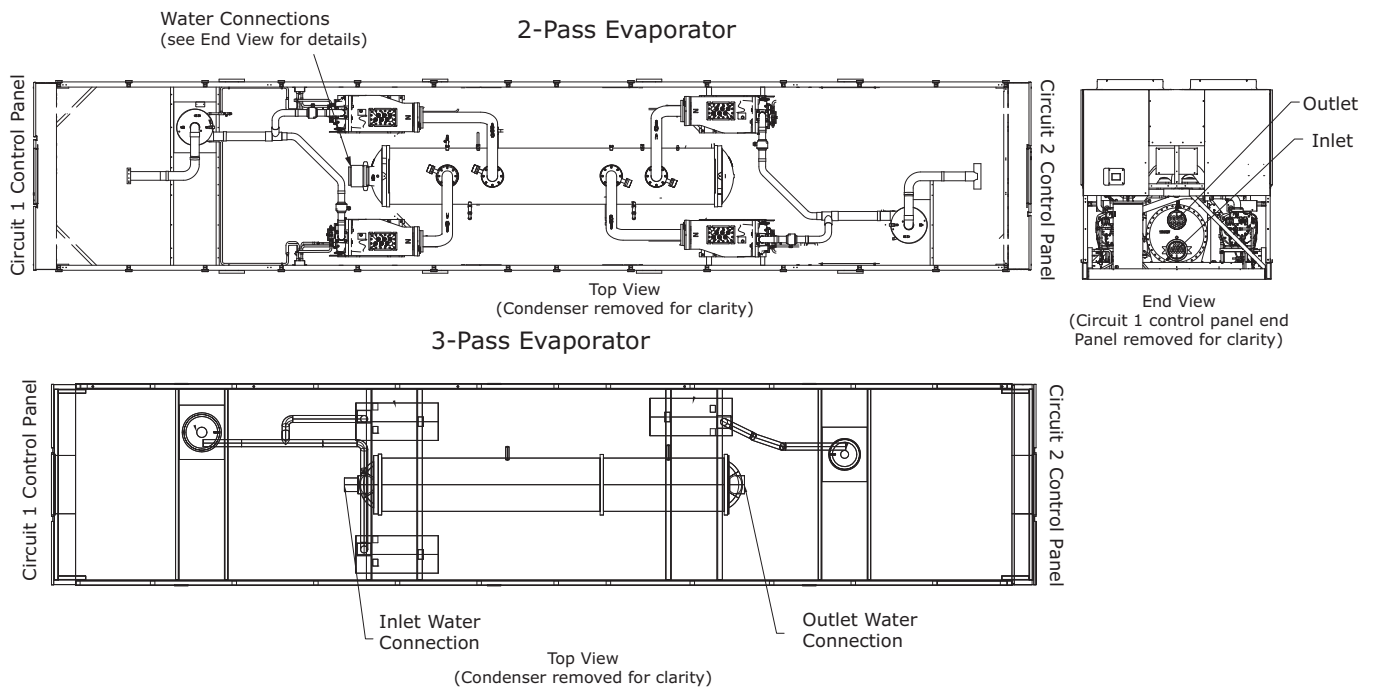

Figure 21. Evaporator pass configurations - 3 or 4 compressor units





Installation - Mechanical

Thoroughly flush all water piping to the unit before making the final piping connections to the unit.

Components and layout will vary slightly, depending on the location of connections and the water source.

NOTICE:

Evaporator Damage!

The chilled water connections to the evaporator are to be "victaulic" type connections. Do not attempt to weld these connections, as the heat generated from welding can cause microscopic and macroscopic fractures on the cast iron waterboxes that can lead to premature failure of the waterbox. To prevent damage to chilled water components, do not allow evaporator pressure (maximum working pressure) to exceed 150 psig (10.5 bar).

Provide shutoff valves in gauge lines to isolate them from system when not in use. Use rubber vibration eliminators to prevent vibration transmission through water lines. If desired, install thermometers in lines to monitor entering and leaving water temperatures. Install a balancing valve in leaving water line to control water flow balance. Install shutoff valves on both entering and leaving water lines so evaporator can be isolated for service.

NOTICE:

Evaporator Damage!

To prevent evaporator damage, pipe strainers must be installed in the water supplies to protect components from water born debris. Trane is not responsible for equipment-only-damage caused by water born debris.

"Piping components" include all devices and controls used to provide proper water system operation and unit operating safety. These components and their general locations are given below.

Entering Chilled Water Piping

- Air vents (to bleed air from system).
- Water pressure gauges with shutoff valves.
- Vibration eliminators.
- Shutoff (isolation) valves. Thermometers (if desired).
- Clean-out tees.
- Pipe strainer.

Leaving Chilled Water Piping

- Air vents (to bleed air from system).
- Water pressure gauges with shutoff valves.
- Vibration eliminators.
- Shutoff (isolation) valves.
- Thermometers.
- Clean-out tees.
- Balancing valve.

Evaporator Drain

A 1/2" drain connection is located under outlet end of evaporator waterbox for drainage during unit servicing. A shutoff valve must be installed on drain line.

Evaporator Flow Switch

The flow switch is factory-installed and programmed based on the operating conditions submitted with the order. The leaving evaporator temperature, fluid type and fluid concentration affect the selected flow switch. If the operating conditions on the job site change, the flow switch may need to be replaced.

The sensor head includes 3 LEDs, two yellow and one green. Wait 15 seconds after power is applied to the sensor before evaluating LEDs for flow status. When wired correctly and flow is established, only the green LED should be lit. Following are the LED indicators:

- Green ON, both yellow OFF — Flow
- Green and outside yellow ON — No Flow
- Center yellow ON continuously — Miswire

Factory installed jumper wire W3 must be removed if using auxiliary contacts and/or additional proof of flow. See schematics in RTAC-SVE01*-EN for more details.

NOTICE:

Equipment Damage!

Incorrect wiring of auxiliary contacts could result in equipment damage.

Note: Use caution when connecting auxiliary contacts. Terminals 1TB6-3 and 1TB6-5 are to be used for field connections. Inadvertent use of 1TB6-5 and 1TB6-4 will result in a FALSE FLOW indication.

If using auxiliary flow sensing, both yellow LEDs come on initially when flow is stopped. Center yellow LED will turn off after approximately 7 seconds. LED indicators are otherwise same as indicated above.

NOTICE:

Proper Water Treatment!

The use of untreated or improperly treated water in this equipment could result in scaling, erosion, corrosion, algae or slime. It is recommended that the services of a qualified water treatment specialist be engaged to determine what water treatment, if any, is required. Trane assumes no responsibility for equipment failures which result from untreated or improperly treated water, or saline or brackish water.

Important: If using an acidic commercial flushing solution, construct a temporary bypass around the unit to prevent damage to internal components of the evaporator.

Dirt, scale, products of corrosion and other foreign material will adversely affect heat transfer between the water and system components. Foreign matter in chilled water system can also increase pressure drop and reduce water flow. Proper water treatment must be determined locally, depending on system and local water characteristics.

Neither salt nor brackish water is recommended. Use of either will lead to a shortened life to an indeterminable degree. The Trane Company encourages the service of a reputable water treatment specialist, familiar with local water conditions, to assist in this determination and in establishment of a proper water treatment program.

Using untreated or improperly treated water in these units may result in inefficient operation and possible tube damage. Consult a qualified water treatment specialist to determine whether treatment is needed.

Indexing Flow Switch

To properly index flow switch, the following requirements must be met:

- Dot must be at a position no greater than 90° off Index.
- Torque must be between 22 ft-lb min and 74 ft-lb max.
- A minimum distance of 5x pipe diameter must be maintained between flow switch and any bends, valves, changes in cross sections, etc.

Figure 22. Proper flow switch indexing

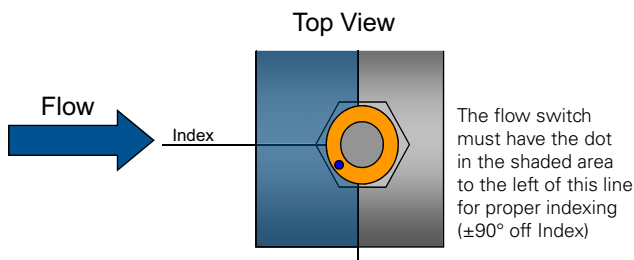

Figure 23. Evaporator water pressure drop— 2-pass evaporator — 120-250 ton

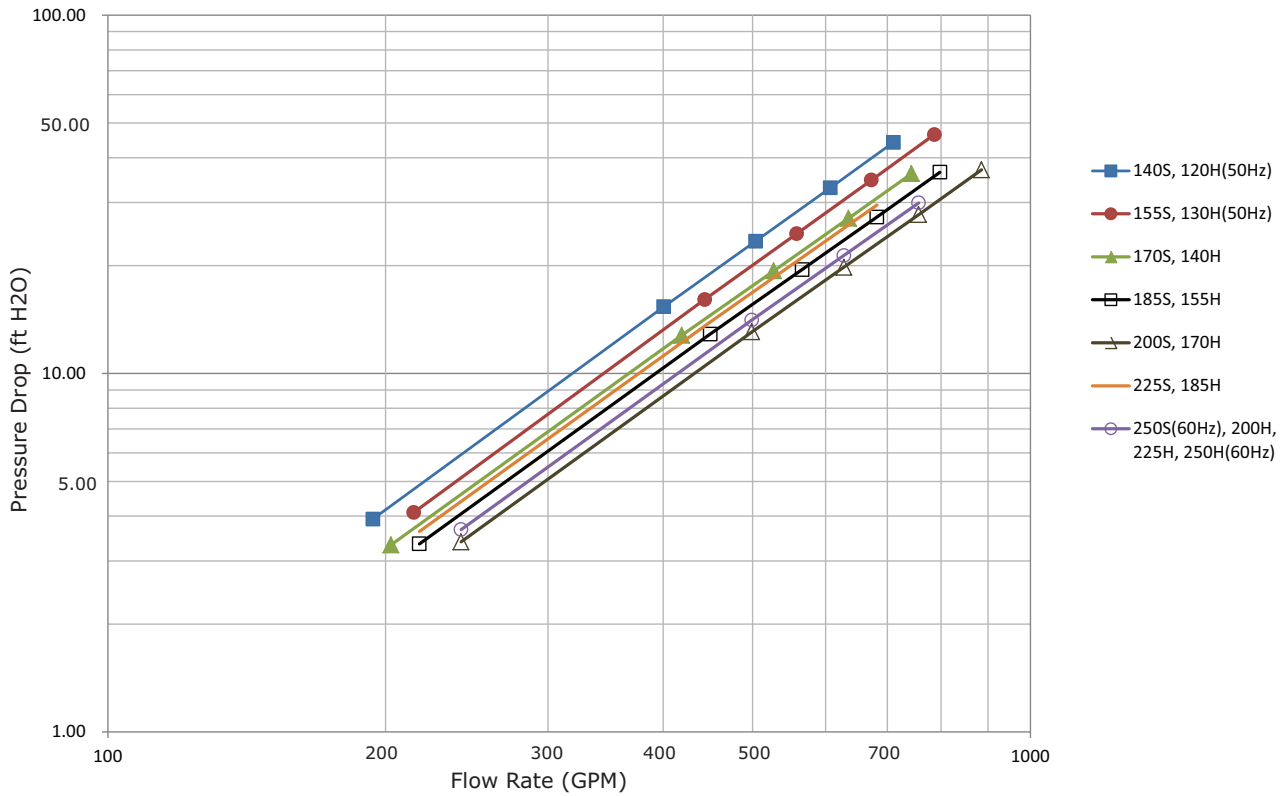

Figure 24. Evaporator water pressure drop — 2-pass evaporator — 250-500 ton

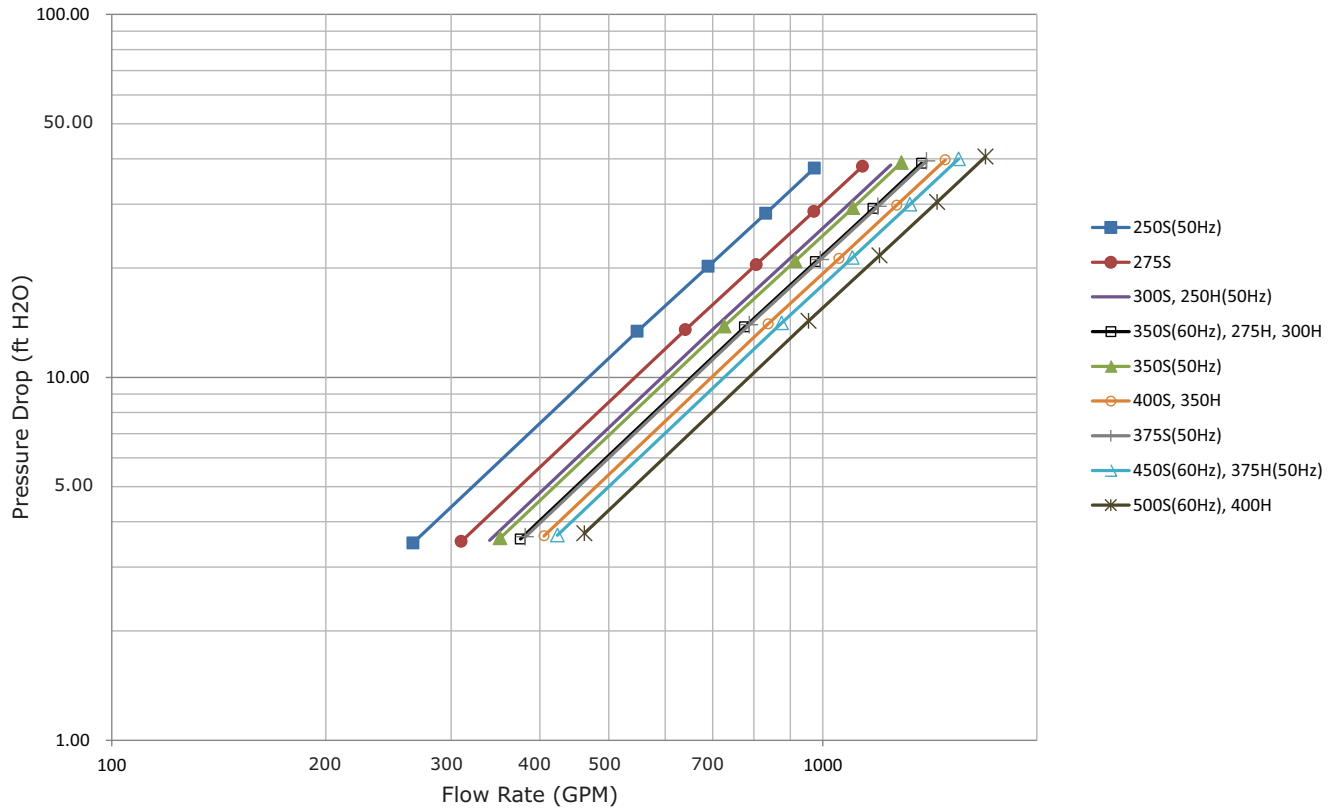

Figure 25. Evaporator water pressure drop – 3-pass evaporator – 140-250T

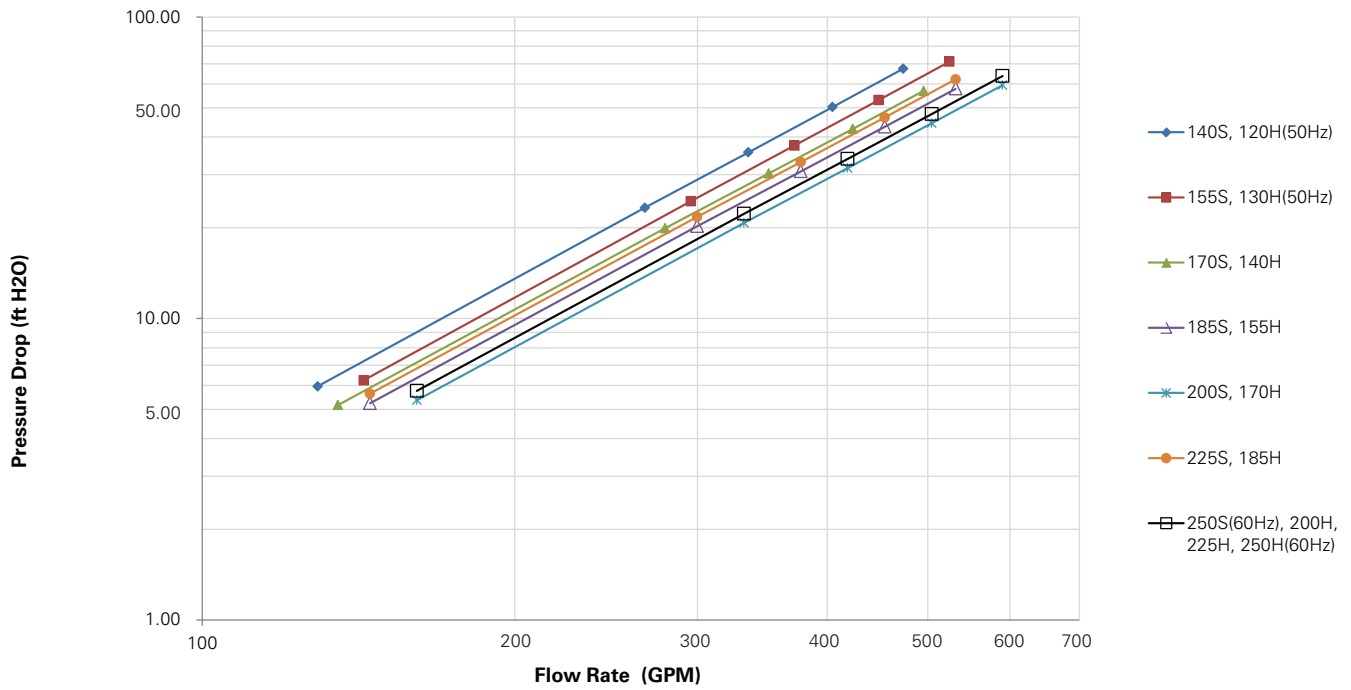
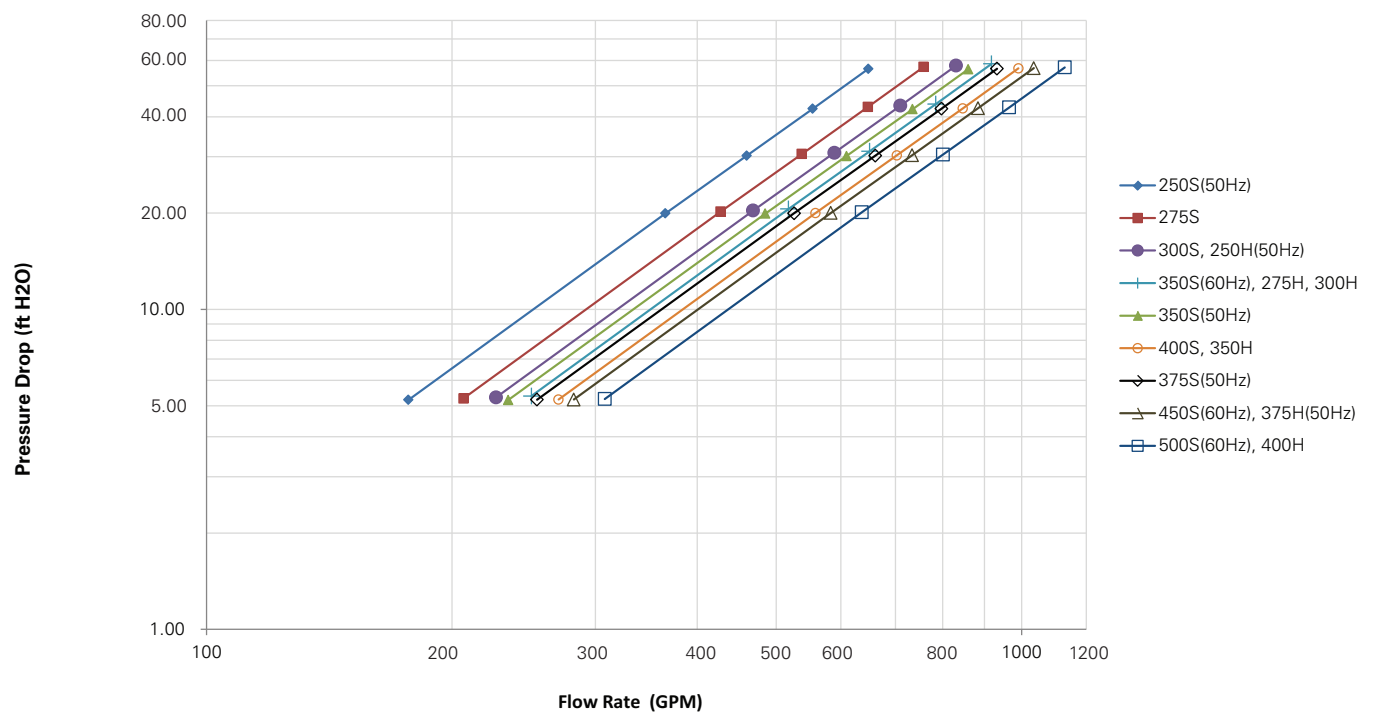
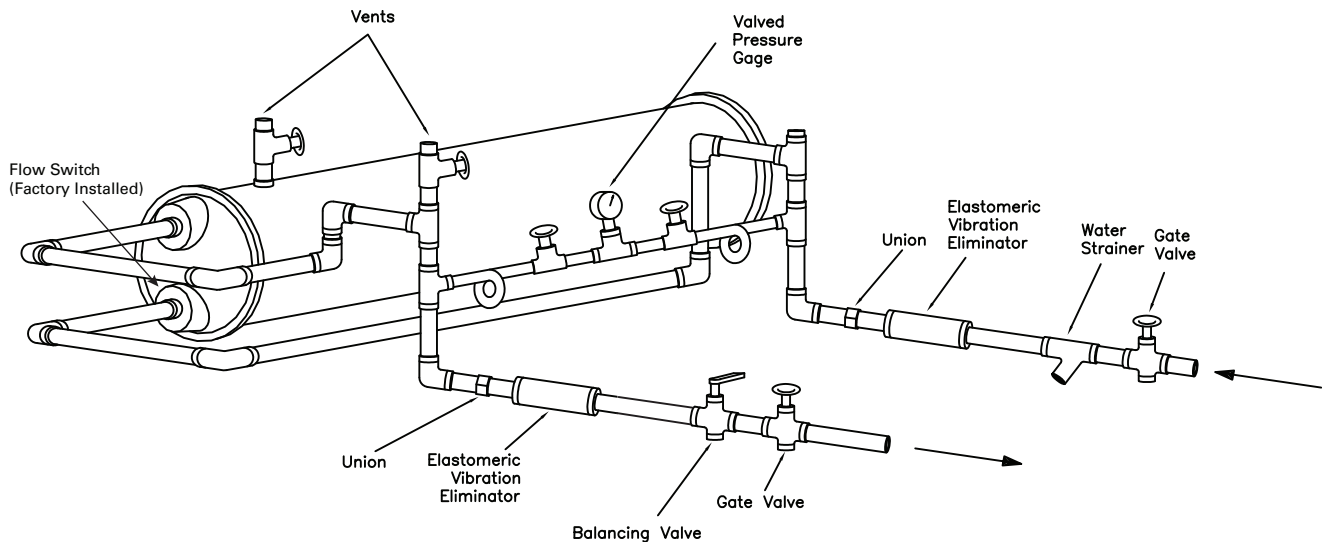

Figure 26. Evaporator water pressure drop – 3-pass evaporator – 250-500T



Water Pressure Gauges

Figure 27. Suggested piping for typical RTAC evaporator



Install field-supplied pressure components as shown in [Figure 27, p. 52](#). Locate pressure gauges or taps in a straight run of pipe; avoid placement near elbows, etc. Be sure to install the gauges at the same elevation on each shell if the shells have opposite-end water connections.

Note: Once the unit is installed at a site, one vertical or one diagonal unit support can be permanently removed if it creates an obstruction for water piping.

To read manifolded pressure gauges, open one valve and close the other (depending upon the reading desired). This eliminates errors resulting from differently calibrated gauges installed at unmatched elevations.

Water Pressure Relief Valves

NOTICE:

Evaporator Damage!

To prevent shell damage, install pressure relief valves in the evaporator water system.

Install a water pressure relief valve in the evaporator inlet piping between the evaporator and the inlet shutoff valve, as shown in [Figure 27, p. 52](#). Water vessels with close-coupled shutoff valves have a high potential for hydrostatic pressure buildup on a water temperature increase. Refer to applicable codes for relief valve installation guidelines.

Freeze Avoidance

One or more of the ambient freeze avoidance methods in [Table 41](#) must be used to protect the RTAC chiller from ambient freeze damage.

Note: A secondary set of pump interlock is **strongly recommended**, but not required.

Table 41. RTAC freeze avoidance methods

Method	Protects to ambient temperature	Notes
Water Pump Control AND Heaters	Down to -20°F	<ul style="list-style-type: none"> • Heaters alone will provide low ambient protection down to -20°F (-29°C), but will NOT protect the evaporator from freezing as a result of charge migration. Therefore, it is required that water pump control be used in conjunction with heaters. • Heaters are factory-installed on the evaporator and water piping and will protect them from freezing • Install heat tape on all water piping, pumps, and other components that may be damaged if exposed to freezing temperatures. Heat tape must be designed for low ambient temperature applications. Heat tape selection should be based on the lowest expected ambient temperature. • CH530 controller can start the pump when freezing conditions are detected. For this option the pump must be controlled by the RTAC unit and this function must be validated. • Water circuit valves need to stay open at all times. • Water pump control and heater combination will protect the evaporator down to any ambient temperature provided power is available to the pump and the CH530 controller. This option will NOT protect the evaporator in the event of a power failure to the chiller unless backup power is supplied to the necessary components. • When no chiller operation is possible and the pump is already off, CH530 pump control for freeze protection will command the pump to turn: <ul style="list-style-type: none"> ON if liquid level > -0.83" AND evap sat temp < LWTC for 30°F-sec (17°C-sec) OFF again if evaporator saturated temperature > LWTC OR liquid level < -0.83" for 30 minutes. ON if entering OR leaving water temperature < LWTC for 30°F-sec (17°C-sec) OFF again if water temperature > LWTC for 30 min (where LWTC is leaving water temperature cutout)
Freeze Inhibitor	Varies. See "Low Evaporator Refrigerant Cutout, Glycol Recommendations," p. 54	<ul style="list-style-type: none"> • Freeze protection can be accomplished by adding sufficient glycol to protect against freezing below the lowest ambient expected. • Use of glycol type antifreeze reduces the cooling capacity of the unit and must be considered in the design of the system specifications.
Drain Water Circuit	Below -20°F	<ul style="list-style-type: none"> • Shut off the power supply to the unit and to all heaters. • Purge the water circuit. • Blow out the evaporator to ensure no liquid is left in the evaporator.

NOTICE:

Evaporator Damage!

If insufficient concentration or no glycol is used, the evaporator water flow must be controlled by the CH530 AND heaters must be used to avoid catastrophic damage to the evaporator due to freezing. It is the responsibility of the installing contractor and/or the customer to ensure that a pump will start when called upon by the chiller controls.

Even with water pump control, a power loss of as little as 15 minutes under freezing conditions can damage the evaporator. Only the proper addition of freeze inhibitor or complete drainage of the water circuit can ensure no evaporator damage in the event of a power failure. See [Table 42, p. 54](#) for correct concentration of glycol.



Low Evaporator Refrigerant Cutout, Glycol Recommendations

1. Solution freeze point is 4 deg F below operating point saturation temperature.
2. LRTC is 4 deg F below freeze point.

Procedure

1. Is operating condition contained within [Table 42, p. 54](#)? If no, see “Specials,” [p. 54](#).
2. For leaving fluid temperatures greater than 40 deg F, use settings for 40 deg F.
3. Select operating conditions from [Table 42](#).
4. Read off recommended % glycol.
5. Go to [Table 43, p. 55](#) using the % glycol determined above.

Important: Additional glycol beyond the recommendations will adversely effect unit performance. Unit efficiency and saturated evaporator temperature will be reduced. For some operating conditions this effect can be significant.

6. If additional glycol is used, then use the actual % glycol to establish the low refrigerant cutout setpoint.
7. The minimum low refrigerant cutout setpoint allowed is -5 deg F. The minimum is established by the solubility limits of the oil in the refrigerant.

Specials

Any of the following conditions are considered special applications that must be calculated by engineering:

1. Freeze inhibitor other than ethylene glycol, propylene glycol, calcium chloride or methanol.
2. Fluid delta T outside the range 4 to 16 deg F.
3. Unit configuration other than Standard, Standard with extra pass, and Premium.
4. % Glycol greater than maximum in column in [Table 43](#).

Special should all be calculated by engineering. The purpose of calculating is to make sure that design saturation temperature is greater than 3 deg F. Additionally, the calculation must verify that the fluid freeze point is a minimum of 4 deg. F lower that the design saturation temperature. The low evaporator temperature cutout will be 4 deg F below the freeze point or -5 deg F, whichever is greater.

Important: When using glycol, Techview Setpoint View setting for “Freeze Inhibitor Present” must be set to “Yes” to prevent nuisance high approach diagnostic.

Table 42. Glycol recommendations

DT		Ethylene Glycol						
		4	6	8	10	12	14	16
°F	°C	15	-14	-13	-12	-11	-10	-9
Leaving Water Temperature °F (°C)	38 (3)	--	5	5	5	5	6	--
	34 (1)	--	11	11	11	12	--	--
	30 (-1)	--	15	16	17	18	--	--
	28 (-2)	--	18	18	19	--	--	--
	26 (-3)	--	20	21	22	--	--	--
	24 (-4)	--	22	23	26	--	--	--
	22 (-6)	--	24	26	--	--	--	--
	20 (-7)	--	26	30	--	--	--	--
	18 (-8)	--	29	--	--	--	--	--
	16 (-9)	--	31	--	--	--	--	--
	14 (-10)	30	--	--	--	--	--	--
12 (-11)	32	--	--	--	--	--	--	
10.4 (-12)	34	--	--	--	--	--	--	
DT		Propylene Glycol						
		4	6	8	10	12	14	16
°F	°C	-15	-14	-13	-12	-11	-10	-9
Leaving Water Temperature °F (°C)	38 (3)	--	6	6	7	7	8	--
	34 (1)	--	13	13	15	17	--	--
	30 (-1)	--	19	21	--	--	--	--
	28 (-2)	--	22	--	--	--	--	--
	26 (-3)	--	25	--	--	--	--	--
	24 (-4)	--	--	--	--	--	--	--
	22 (-6)	--	--	--	--	--	--	--
	20 (-7)	--	--	--	--	--	--	--
	18 (-8)	--	--	--	--	--	--	--
	16 (-9)	--	--	--	--	--	--	--
	14 (-10)	--	--	--	--	--	--	--
12 (-11)	--	--	--	--	--	--	--	
10.4 (-12)	--	--	--	--	--	--	--	

Notes:

1. These tables represent the MINIMUM RECOMMENDED glycol percentages for each operating condition
2. Operation is not recommended at certain operating conditions as some chillers may not satisfy maximum or minimum velocity requirements or minimum performance requirements. Contact Trane Sales Representative for more information regarding the operating limits of a particular chiller.

Table 43. Recommended low evaporator refrigerant cutout and percent glycol

% Glycol	Low Refrig. Temp Cutout		Solution Freeze Point	
	°F	°C	°F	°C
Ethylene				
0	28.0	-2.2	32	0
5	25.0	-3.9	29	-1.7
10	21.5	-5.8	25.5	-3.6
15	17.5	-8.1	21.5	-5.8
20	12.8	-10.7	16.8	-8.4
25	7.4	-13.7	11.4	-11.4
30	1.1	-17.2	5.1	-15.0
35	-5.0	-20.6	-2.3	-19.1
40	-5.0	-20.6	-10.8	-23.8
45	-5.0	-20.6	-20.7	-29.3
50	-5.0	-20.6	-32.1	-35.6
54	-5.0	-20.6	-42.3	-41.3
Propylene Glycol				
0	28.0	-2.2	32.0	0
5	25.3	-3.7	29.3	-1.5
10	22.4	-5.3	26.4	-3.1
15	19.1	-7.2	23.1	-4.9
20	15.3	-9.3	19.3	-7.1
25	10.8	-11.8	14.8	-9.6
30	5.3	-14.8	9.3	-12.6
35	-1.3	-19.5	2.7	-16.3
40	-5.0	-20.6	-5.2	-20.7
45	-5.0	-20.6	-14.6	-25.9
50	-5.0	-20.6	-25.8	-32.1
54	-5.0	-20.6	-36.1	-37.8

Chilled Water Temperature Cutout should be set to 5°F below the lowest allowable Chilled Water Set Point bases on the %Glycol.



Installation - Mechanical

Remote Evaporator Option

The **RTAC 140-250 ton** outdoor unit with the Remote Evaporator option is shipped as two pieces: the outdoor unit (condensing) and the evaporator. Short suction line connections are provided with the outdoor condensing unit. The remote evaporator is shipped complete, with factory-mounted electronic expansion valves, water temperature sensors, suction pressure transducers, liquid level control sensors, evaporator flow switch, all factory wired to a ribbon cable. Solenoid valves and drain valves are wired to a relay board in the terminal box. The installing contractor is required to provide and install the following:

- 2-wire, twisted shielded communication line between the remote evaporator terminal box and the Condensing Unit's control panel
- 4-wire connection from evaporator terminal box to condensing unit control panel for flow switch wiring (see [Figure 32, p. 64](#))
- 115 VAC single phase power supply to the remote evaporator terminal box
- 2 liquid lines
- 2 suction lines
- Suction accumulator as specified

Note: A unit ordered as a remote evaporator must also be ordered with either the wide or low ambient option. The fan inverters are necessary for proper control.

System Configuration and Interconnecting Refrigerant Piping

The system may be configured in any of the four arrangements shown in [Figure 28, p. 57](#). The configurations and their associated elevations, along with the total distance between the remote evaporator and the compressor/condenser section, play a critical role in determining suction and liquid line sizes. This will also affect field refrigerant and oil charges. Consequently, there are physical limits which must not be violated if the system is to operate as designed. Please note the following requirements for field installation:

1. The remote evaporator **MUST** be matched with its respective outdoor condensing unit.
2. The circuit number on the outdoor condensing unit must match the circuit number on the evaporator, i.e. circuit #1 on the outdoor condensing unit must be connected with circuit # 1 on the remote evaporator and likewise for circuit #2. RTAC Circuit Capacities are shown in General Data Tables.

NOTICE:

Equipment Damage!

If the circuits are crossed, serious equipment damage could occur.

3. Piping between the evaporator and outdoor unit can not exceed 200 actual feet and/or an equivalent length of 300 feet.

Note: The latter includes the equivalent length of all associated field installed fittings, valves, accessories and straight lengths of interconnecting piping.

4. Horizontal portions of suction lines must be downward sloping toward the compressor at least 1/2 inch for each 10 feet run. This promotes the movement of oil in the direction of gas flow.
5. Suction lines must be insulated.
6. The line sizes defined are to be used only for 40-60 F leaving water temperature and/or full load ice-making applications.
7. [Figure 28, p. 57](#), drawing 1 depicts an installation where the remote evaporator elevation is the same as that of the outdoor condensing unit. The suction and liquid lines are horizontal or down flowing only.

The suction and liquid lines can be put under ground or in a trench. The temperature of the suction lines must never exceed the temperature of the compressor. The line can be below the compressors a maximum of 15 ft.

8. [Figure 28, p. 57](#), drawing 2 shows a variation to drawing 1. The remote evaporator and outdoor condensing unit are at the same elevation but interconnecting piping may be installed up to 15 feet above the base elevation. Refer to [Table 46, p. 60](#) to determine the required length of the suction accumulator line. A full size suction accumulator is required at the evaporator and 50% of the value is required at the condensing unit.
9. A refrigerant drain valve is installed at the bottom of the evaporator for freeze protection. This drain valve is a normally open, pilot operated valve which remains closed unless there is a potential freezing situation detected via low evap temperatures or low water temperatures or a power failure. If the drain valve is opened the installed suction accumulator must be capable of holding the entire evaporator charge. Refer to [Table 46, p. 60](#) for sizing.
10. For installations where the remote evaporator is at a lower elevation than the outdoor condensing unit as shown in [Figure 28, p. 57](#), drawing 3, the elevation difference is not to exceed 100 feet. An inverted liquid

Installation - Mechanical Remote Evaporator Option

line trap at the condensing unit is required to prevent unwanted free cooling. The apex of the liquid line trap should be at a height above the condenser coils. A suction accumulator must be installed at the evaporator. Refer to [Table 46, p. 60](#) for sizing.

- When the elevation of the remote evaporator exceeds that of the outdoor condensing unit as shown in [Figure 28, p. 57, drawing 4](#), the elevation difference is determined by [Table 44, p. 59](#). The suction accumulator line must be installed according to [Table 46, p. 60](#). It is very important, for proper control

and operation of the chiller, that the elevation requirements given in [Table 44, p. 59](#) are **not** exceeded. It should also be noted that in this configuration the suction accumulator is installed at the condensing section.

- Note:** The height is limited by the available subcooling.
- Compressor & oil separator heaters must be on at least 24 hours prior to compressor start.

Figure 28. Remote evaporator installations

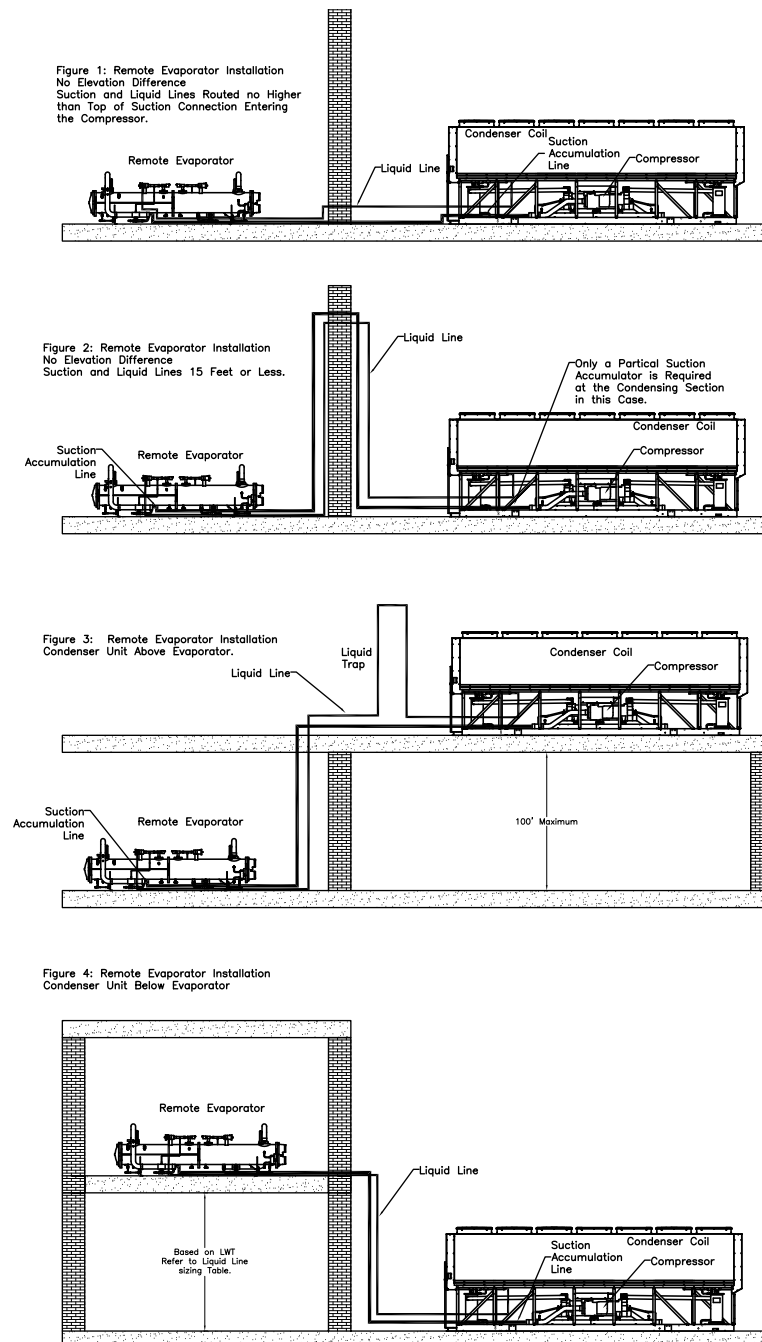



Installation - Mechanical Remote Evaporator Option

Figure 29. Circuit identification

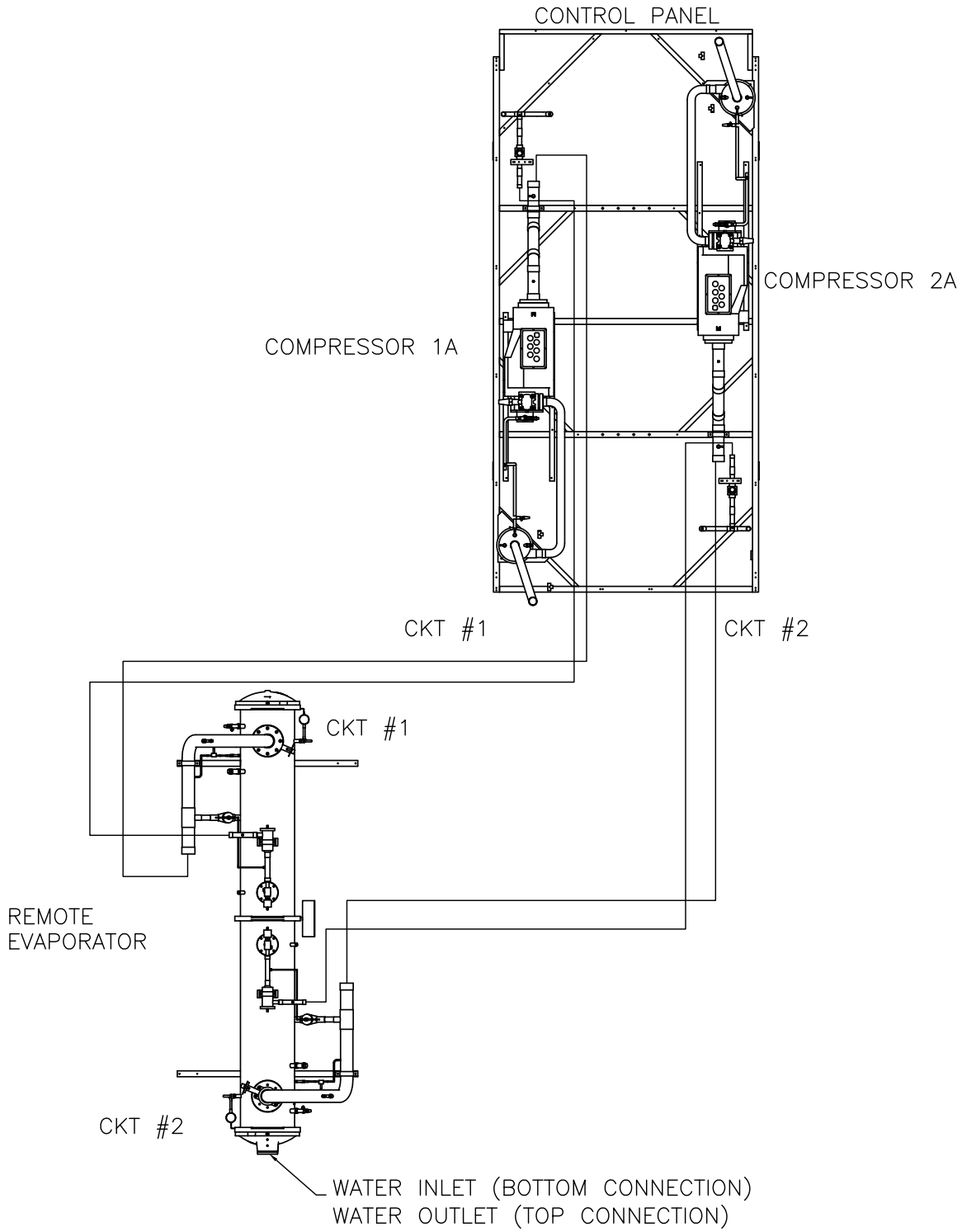

Installation - Mechanical Remote Evaporator Option

Table 44. Liquid line sizing^(a) - 140-250T remote evaporator

	Leaving water 40-50°F									Leaving water 50-60°F							
	Height (ft)									Height (ft)							
Total Equivalent Length (ft)	0	1-5	6-10	11-15	16-20	21-25	26-30	31-35	0	1-5	6-10	11-15	16-20	21-25	26-30		
70-ton circuit																	
25	1.375	1.375	1.375	1.375	1.375	1.375	1.375	n/a	25	1.375	1.375	1.375	1.375	1.375	1.375	2.125	
50	1.375	1.375	1.375	1.375	1.375	1.375	1.375	n/a	50	1.375	1.375	1.375	1.375	1.375	1.625	2.125	
75	1.375	1.375	1.375	1.375	1.375	1.375	1.625	n/a	75	1.375	1.375	1.375	1.375	1.375	1.625	n/a	
100	1.375	1.375	1.375	1.375	1.375	1.375	1.625	n/a	100	1.375	1.375	1.375	1.375	1.625	2.125	n/a	
125	1.375	1.375	1.375	1.375	1.375	1.625	1.625	n/a	125	1.375	1.375	1.375	1.625	1.625	2.125	n/a	
150	1.375	1.375	1.375	1.375	1.375	1.625	n/a	n/a	150	1.375	1.375	1.375	1.625	1.625	2.125	n/a	
175	1.375	1.375	1.375	1.375	1.625	1.625	n/a	n/a	175	1.375	1.375	1.625	1.625	1.625	2.125	n/a	
200	1.375	1.375	1.375	1.375	1.625	1.625	n/a	n/a	200	1.375	1.625	1.625	1.625	2.125	2.125	n/a	
225	1.375	1.375	1.375	1.625	1.625	1.625	n/a	n/a	225	1.375	1.625	1.625	1.625	2.125	2.125	n/a	
250	1.375	1.375	1.375	1.625	1.625	n/a	n/a	n/a	250	1.625	1.625	1.625	1.625	2.125	2.125	n/a	
275	1.375	1.375	1.625	1.625	1.625	n/a	n/a	n/a	275	1.625	1.625	1.625	2.125	2.125	2.125	n/a	
300	1.375	1.375	1.625	1.625	1.625	n/a	n/a	n/a	300	1.625	1.625	1.625	2.125	2.125	2.125	n/a	
85-ton circuit																	
25	1.375	1.375	1.375	1.375	1.375	1.375	2.125	n/a	25	1.375	1.375	1.375	1.375	2.125	n/a	n/a	
50	1.375	1.375	1.375	1.375	1.375	1.625	n/a	n/a	50	1.375	1.375	1.375	1.625	2.125	n/a	n/a	
75	1.375	1.375	1.375	1.375	1.375	1.625	n/a	n/a	75	1.375	1.375	1.625	1.625	n/a	n/a	n/a	
100	1.375	1.375	1.375	1.375	1.625	1.625	n/a	n/a	100	1.375	1.625	1.625	2.125	n/a	n/a	n/a	
125	1.375	1.375	1.375	1.625	1.625	2.125	n/a	n/a	125	1.375	1.625	1.625	2.125	n/a	n/a	n/a	
150	1.375	1.375	1.375	1.625	1.625	2.125	n/a	n/a	150	1.625	1.625	1.625	2.125	n/a	n/a	n/a	
175	1.375	1.375	1.625	1.625	1.625	2.125	n/a	n/a	175	1.625	1.625	2.125	2.125	n/a	n/a	n/a	
200	1.375	1.625	1.625	1.625	2.125	2.125	n/a	n/a	200	1.625	1.625	2.125	2.125	n/a	n/a	n/a	
225	1.375	1.625	1.625	1.625	2.125	2.125	n/a	n/a	225	1.625	2.125	2.125	2.125	n/a	n/a	n/a	
250	1.625	1.625	1.625	1.625	2.125	2.125	n/a	n/a	250	1.625	2.125	2.125	2.125	n/a	n/a	n/a	
275	1.625	1.625	1.625	1.625	2.125	2.125	n/a	n/a	275	1.625	2.125	2.125	2.125	n/a	n/a	n/a	
300	1.625	1.625	1.625	2.125	2.125	2.125	n/a	n/a	300	2.125	2.125	2.125	2.125	n/a	n/a	n/a	
100-ton circuit																	
25	1.625	1.625	1.625	1.625	1.625	1.625	1.625	1.625	25	1.625	1.625	1.625	1.625	1.625	1.625	1.625	
50	1.625	1.625	1.625	1.625	1.625	1.625	1.625	1.625	50	1.625	1.625	1.625	1.625	1.625	1.625	1.625	
75	1.625	1.625	1.625	1.625	1.625	1.625	1.625	1.625	75	1.625	1.625	1.625	1.625	1.625	1.625	2.125	
100	1.625	1.625	1.625	1.625	1.625	1.625	1.625	2.125	100	1.625	1.625	1.625	1.625	1.625	1.625	2.125	
125	1.625	1.625	1.625	1.625	1.625	1.625	1.625	2.125	125	1.625	1.625	1.625	1.625	1.625	2.125	2.125	
150	1.625	1.625	1.625	1.625	1.625	1.625	2.125	2.125	150	1.625	1.625	1.625	1.625	1.625	2.125	2.125	
175	1.625	1.625	1.625	1.625	1.625	1.625	2.125	2.125	175	1.625	1.625	1.625	1.625	2.125	2.125	2.125	
200	1.625	1.625	1.625	1.625	1.625	2.125	2.125	2.125	200	1.625	1.625	1.625	2.125	2.125	2.125	2.125	
225	1.625	1.625	1.625	1.625	1.625	2.125	2.125	2.125	225	1.625	1.625	1.625	2.125	2.125	2.125	2.125	
250	1.625	1.625	1.625	1.625	1.625	2.125	2.125	2.125	250	1.625	1.625	2.125	2.125	2.125	2.125	2.625	
275	1.625	1.625	1.625	1.625	2.125	2.125	2.125	2.125	275	1.625	1.625	2.125	2.125	2.125	2.125	2.625	
300	1.625	1.625	1.625	1.625	2.125	2.125	2.125	n/a	300	1.625	2.125	2.125	2.125	2.125	2.125	2.625	
120-ton circuit																	
25	1.625	1.625	1.625	1.625	1.625	1.625	1.625	2.125	25	1.625	1.625	1.625	1.625	1.625	1.625	1.625	
50	1.625	1.625	1.625	1.625	1.625	1.625	1.625	2.125	50	1.625	1.625	1.625	1.625	1.625	1.625	1.625	
75	1.625	1.625	1.625	1.625	1.625	1.625	2.125	2.625	75	1.625	1.625	1.625	1.625	1.625	1.625	2.125	
100	1.625	1.625	1.625	1.625	1.625	1.625	2.125	2.625	100	1.625	1.625	1.625	1.625	1.625	1.625	2.125	
125	1.625	1.625	1.625	1.625	1.625	2.125	2.125	2.625	125	1.625	1.625	1.625	1.625	1.625	2.125	2.125	
150	1.625	1.625	1.625	1.625	1.625	2.125	2.125	2.625	150	1.625	1.625	1.625	1.625	1.625	2.125	2.125	
175	1.625	1.625	1.625	1.625	2.125	2.125	2.125	2.625	175	1.625	1.625	1.625	1.625	2.125	2.125	2.125	
200	1.625	1.625	1.625	1.625	2.125	2.125	2.125	2.625	200	1.625	1.625	1.625	2.125	2.125	2.125	2.125	
225	1.625	1.625	1.625	2.125	2.125	2.125	2.125	n/a	225	1.625	1.625	1.625	2.125	2.125	2.125	2.125	
250	1.625	1.625	1.625	2.125	2.125	2.125	2.125	2.625	250	1.625	1.625	2.125	2.125	2.125	2.125	2.625	
275	1.625	1.625	2.125	2.125	2.125	2.125	2.625	n/a	275	1.625	1.625	2.125	2.125	2.125	2.125	2.625	
300	1.625	2.125	2.125	2.125	2.125	2.125	2.625	n/a	300	1.625	2.125	2.125	2.125	2.125	2.125	2.625	

(a) Typical type L copper O.D.



Installation - Mechanical Remote Evaporator Option

Line Sizing

To determine the appropriate outside diameter for field installed liquid and suction lines, it is first necessary to establish the equivalent length of pipe for each line. It is also necessary to know the capacity (tons) of each circuit. Circuit capacities for each RTAC unit are listed in [Table 1, p. 10](#) through [Table 10, p. 19](#).

Table 45. Equivalent lengths of non-ferrous valves and fittings (feet)

Line Size Inches OD	Globe Valve	Short Angle Valve	Short Radius ELL	Long Radius ELL
1-1/8	87	29	2.7	1.9
1-3/8	102	33	3.2	2.2
1-5/8	115	34	3.8	2.6
2-1/8	141	39	5.2	3.4
2-5/8	159	44	6.5	4.2
3-1/8	185	53	8	5.1
3-5/8	216	66	10	6.3
4-1/8	248	76	12	7.3

Liquid Line Sizing Steps

The steps to compute liquid line size are as follows:

1. Compute the actual length of field installed piping.
2. Multiply the length from step # 1 by 1.5 to estimate the equivalent length.

Table 46. Required length of field installed suction line accumulator (ft)

Actual Feet of field installed liquid line	70 Ton Circuit ^(a)			85 Ton Circuit			100 Ton Circuit			120 Ton Circuit		
	O.D. of Field Installed Liquid Line											
	1 3/8"	1 5/8"	2 1/8"	1 3/8"	1 5/8"	2 1/8"	1 5/8"	2 1/8"	2 5/8"	1 5/8"	2 1/8"	2 5/8"
	Length of 3 5/8" Suction Accumulator			Length of 3 5/8" Suction Accumulator			Length of 4 1/8" Suction Accumulator			Length of 4 1/8" Suction Accumulator		
10	43	44	45	52	52	53	43	44	46	52	53	54
20	45	46	49	53	54	57	45	47	50	53	55	58
30	46	48	52	54	56	60	46	49	53	55	58	62
40	48	50	55	56	58	63	48	52	57	56	60	66
50	49	52	59	57	60	67	49	55	61	58	63	70
60	51	54	62	59	62	70	51	57	65	59	66	74
70	52	56	65	60	64	73	53	60	69	61	68	78
80	53	58	69	62	66	77	54	62	73	62	71	81
90	55	60	72	63	68	80	56	65	77	64	73	85
100	56	62	75	64	70	83	57	68	81	66	76	89
110	58	64	79	66	72	87	59	70	85	67	79	93
120	59	66	82	67	74	90	60	73	89	69	81	97
130	61	68	85	69	76	93	62	75	93	70	84	101
140	62	70	89	70	78	97	63	78	97	72	86	105
150	64	72	92	72	80	100	65	81	101	73	89	109
160	65	74	95	73	82	103	67	83	105	75	92	113
170	66	76	99	75	84	107	68	86	108	76	94	117
180	68	78	102	76	86	110	70	88	112	78	97	121
190	69	79	105	77	88	113	71	91	116	80	99	125
200	71	81	109	79	90	117	73	94	120	81	102	129

(a) Circuit 2 of 155 ton premium unit requires an additional 10 feet of suction accumulator length.

3. See [Table 44, p. 59](#) to determine outside diameter corresponding to equivalent length computed in step 2 for height and leaving water temperature of interest.
- Note:** If condenser is at same elevation or above evap, use 0 ft. column.
4. With the outside diameter found in step # 3, use [Table 45, p. 60](#) to determine the equivalent lengths of each fitting in the field installed piping.
 5. Add equivalent lengths of all field installed elbows and valves.
 6. Add the length found in step # 5 to the actual length from step # 1. This is your new equivalent line length.
 7. Using [Table 44, p. 59](#) again, find the outside diameter that corresponds to the new equivalent line length from step # 6. If it is the same as step #3, this is the final equivalent length. Otherwise, proceed to the next step.
 8. Using [Table 45, p. 60](#) and the new outside diameter found in step # 7, find the equivalent line length of each valve and fitting, and sum them.
 9. Add the length found in step # 8 to the actual length from step # 1. This is the new equivalent line length.
 10. With the equivalent line length found in step # 9, use [Table 44, p. 59](#) to select the proper outside diameter for the liquid lines. If the same as in step #7, this is your final equivalent line length. Otherwise, repeat step #7.

Note: Location and quantity of suction accumulator is dependent upon the unit configuration.

Example Liquid Line Sizing

Figure 30. Liquid line sizing example

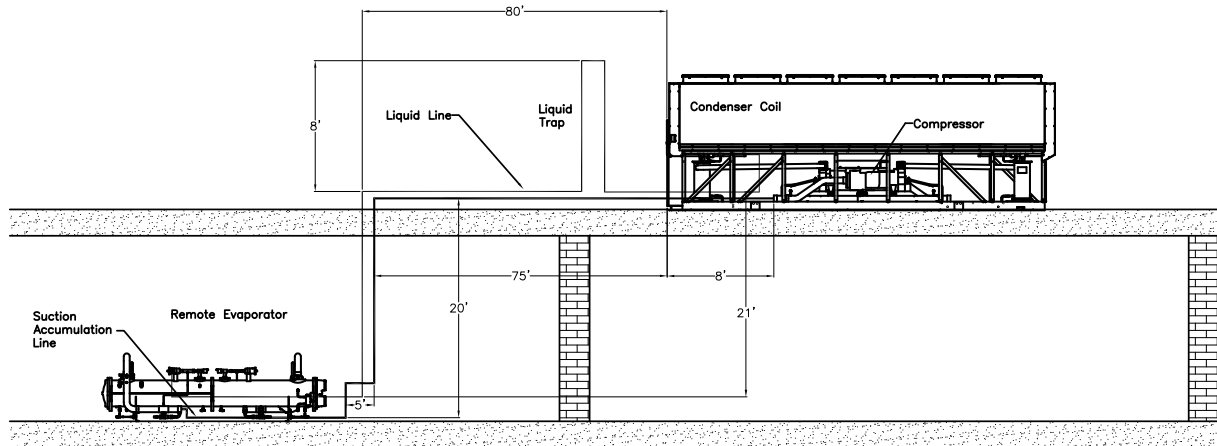

For this example, refer to [Table 44, p. 59](#), [Table 45, p. 60](#) and [Figure 30, p. 61](#). Assume a 70 ton circuit and a leaving water temperature of 49 degrees F.

1. From [Figure 30, p. 61](#), the actual length of field installed piping is:
 $80 + 8 + 8 + 21 = 117$ feet
2. Estimate equivalent line length:
 $117 \text{ feet} \times 1.5 = 175$ feet
3. From [Table 44, p. 59](#) for a 70 ton circuit, for 175 equivalent feet the OD is 1.375 inches.

Note: Use the 0 ft. column since the condenser is above the evap

4. In [Figure 30, p. 61](#), there are six long-radius elbows. From [Table 45, p. 60](#), for 1.375 inch elbows, the equivalent feet is:
 $6 \text{ elbows} \times 2.2 \text{ feet} = 13.2$ feet
5. Adding equivalent feet from step #4 to step #1 gives:
 $13.2 \text{ feet} + 117 \text{ feet} = 130.2$ feet
6. From [Table 44, p. 59](#), for a 70 ton circuit, for 125 equivalent feet (nearest to 130.2), the O.D. is 1- 3/8 inches.

Liquid Line size = 1-3/8 inches

Suction Line Sizing Steps

Table 47. Suction line sizes

Vertical/Upflow and Horizontal/Downflow Suction Lines O.D. (Type L Copper)				
LWT (F)	70 ton circuit	85ton circuit	100 ton circuit	120 ton circuit
40 - 60	3 5/8"	3 5/8"	4 1/8"	4 1/8"

The steps to compute suction line size are as follows:

1. Break the suction line into it's Vertical/Upflow and Horizontal/Downflow components.
2. From [Table 47, p. 61](#), select the appropriate Vertical/Upflow suction line outside diameter according to the circuit tonnage. This is the diameter of the upflow suction line and any fittings in the upflow line.
3. From [Table 47](#), select the appropriate Horizontal/Downflow suction line outside diameter according to the circuit tonnage. This is the diameter of the upflow suction line and any fittings in the upflow line.

Note: The diameters of the upflow, and horizontal or downflow portions of the suction line may differ depending on the application.

Example Suction Line Sizing

For this example, refer to [Table 47](#) and [Figure 30, p. 61](#) assume a 70 ton circuit and a leaving water temperature of 49 degrees F.

1. From [Table 47](#) the vertical/upflow suction line is: 3 5/8" O.D.
2. From [Table 47](#), the horizontal/downflow line is: 3 5/8" O.D.

Note: In this example, the horizontal line is pitched downward in the direction of flow.

Suction Accumulator Sizing

Use [Table 46, p. 60](#) to calculate length and size of the required suction accumulator(s).

Example of Suction Accumulator Line Sizing

Use [Figure 30, p. 61](#) and the same assumptions from the liquid line sizing example to calculate the suction accumulator line size and length.

In this case the accumulator is installed at the evaporator.



Installation - Mechanical Remote Evaporator Option

1. Use the 70 ton circuit column.
2. From the liquid line sizing example, use a field installed liquid line of:
1.375 (1 3/8") inches
3. The actual feet of liquid line installed is: 117 feet
4. The size of the suction accumulator is: 3 5/8 inches
5. The length of the suction line accumulator is: 59 feet

Piping Installation Procedures

⚠ WARNING

Hazard of Explosion and Deadly Gases!

Never solder, braze or weld on refrigerant lines or any unit components that are above atmospheric pressure or where refrigerant may be present. Always remove refrigerant by following the guidelines established by the EPA Federal Clean Air Act or other state or local codes as appropriate. After refrigerant removal, use dry nitrogen to bring system back to atmospheric pressure before opening system for repairs. Mixtures of refrigerants and air under pressure may become combustible in the presence of an ignition source leading to an explosion. Excessive heat from soldering, brazing or welding with refrigerant vapors present can form highly toxic gases and extremely corrosive acids. Failure to follow all proper safe refrigerant handling practices could result in death or serious injury.

NOTICE:

Equipment Damage!

Do not use a saw to remove end caps, as this may allow copper chips to contaminate the system. Use a tubing cutter or heat to remove the end caps.

The outdoor unit and the evaporator are shipped with a 25 psig holding pressure of dry nitrogen. Do not relieve this pressure until field installation of the refrigerant piping is to be accomplished. This will require the removal of the temporary pipe caps.

Note: Use Type L refrigerant-grade copper tubing only.

The refrigerant lines must be isolated to prevent line vibration from being transferred to the building. Do not secure the lines rigidly to the building at any point.

All horizontal suction lines should be pitched downward, in the direction of flow, at a slope of 1/2 inch per 10 feet of run.

Important: Field installed liquid line service valves are recommended for installation. Liquid line service valves are not provided by the factory.

Note: Although packaged unit condensers and evaporators are sized to hold complete refrigerant charge, units with a remote evaporator may not have the same capability, due to additional piping requirements.

Refrigerant Sensors

All necessary refrigerant devices, transducers and solenoids are factory installed and wired to the evaporator terminal box.

Refrigerant Pressure Relief Valve Venting

⚠ WARNING

Confined Space Hazards!

Do not work in confined spaces where refrigerant or other hazardous, toxic or flammable gas may be leaking. Refrigerant or other gases could displace available oxygen to breathe, causing possible asphyxiation or other serious health risks. Some gases may be flammable and or explosive. If a leak in such spaces is detected, evacuate the area immediately and contact the proper rescue or response authority. Failure to take appropriate precautions or to react properly to such potential hazards could result in death or serious injury.

Vent pipe size must conform to the ANSI/ASHRAE Standard 15 for vent pipe sizing. All federal, state, and local codes take precedence over any suggestions stated in this manual.

All relief valve venting is the responsibility of the installing contractor.

All RTAC remote evaporator units use evaporator pressure relief valves (see Figure 31, p. 63) that must be vented to the outside of the building.

Relief valve connection sizes and locations are shown in the unit submittals. Refer to local codes for relief valve vent line sizing information.

NOTICE:

Equipment Damage!

Do not exceed vent piping code specifications. Failure to comply with specifications could result in capacity reduction, unit damage and/or relief valve damage.

Relief valve discharge setpoints and capacities rates are given in Table 48, p. 63. Once the relief valve has opened, it will re-close when pressure is reduced to a safe level.

Once opened, relief valves may have a tendency to leak and must be replaced.

Pressure relief valve discharge capacities will vary with shell diameter and length and also compressor displacement. Discharge venting capacity should be calculated as required by ASHRAE Standard 15-94. Do not adjust relief valve setting in the field.

Table 48. Pressure Relief Valve Data

Unit Sizes	Valve Location	Discharge Setpoint (psi)	Qty	Rated Capacity per Valve (lba/min.)	Field Connection Pipe Size (NPT)	Factory Shell Side Connection (in)
120H - 250S 60Hz/200H/170XE	Evap	200	2	17.3	5/8 MFL	7/8 - 14 UNF-2A
250S 50Hz/225H/185XE - 500S	Evap	200	2	28.9	3/4 NPTFI	7/8 - 14 UNF-2A
All	Oil Sep	350	2	6.3	3/8 MFL	1/4-18 NPTFE

Leak Test and Evacuation

After installation of refrigerant piping, thoroughly test the system for leaks. Pressure test system at pressures required by local codes.

⚠ WARNING

Hazard of Explosion!

Use only dry nitrogen with a pressure regulator for pressurizing unit. Do not use acetylene, oxygen or compressed air or mixtures containing them for pressure testing. Do not use mixtures of a hydrogen containing refrigerant and air above atmospheric pressure for pressure testing as they may become flammable and could result in an explosion. Refrigerant, when used as a trace gas should only be mixed with dry nitrogen for pressurizing units. Failure to follow these recommendations could result in death or serious injury or equipment or property-only damage.

For field evacuation, use a rotary-type vacuum pump capable of pulling a vacuum of 500 microns or less. Follow the pump manufacturer's instructions for proper use of the pump. The line used to connect the pump to the system should be copper and be the largest diameter that can be practically used. A larger line size with minimum flow resistance can significantly reduce evacuation time.

Use the ports on the suction service valves and the liquid line shutoff valves for access to the system for evacuation. Ensure that the suction service valve, the liquid line shutoff valve, the oil line shutoff valve and any field installed valves are open in the proper position before evacuating.

Insulate entire suction line and suction accumulator line. Where line is exposed, wrap with weatherproof tape and seal with weatherproof compound.

Figure 31. Remote evaporator

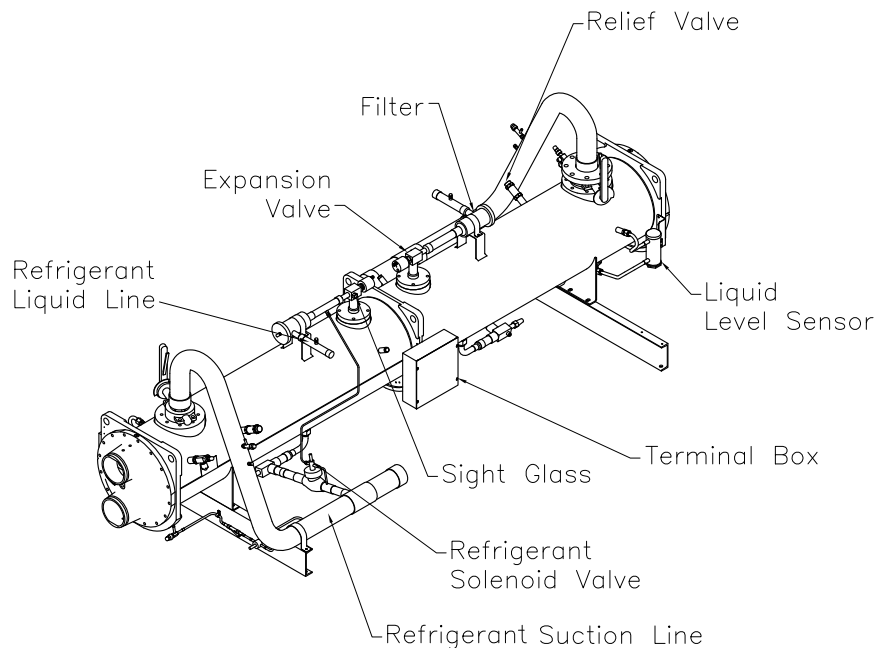
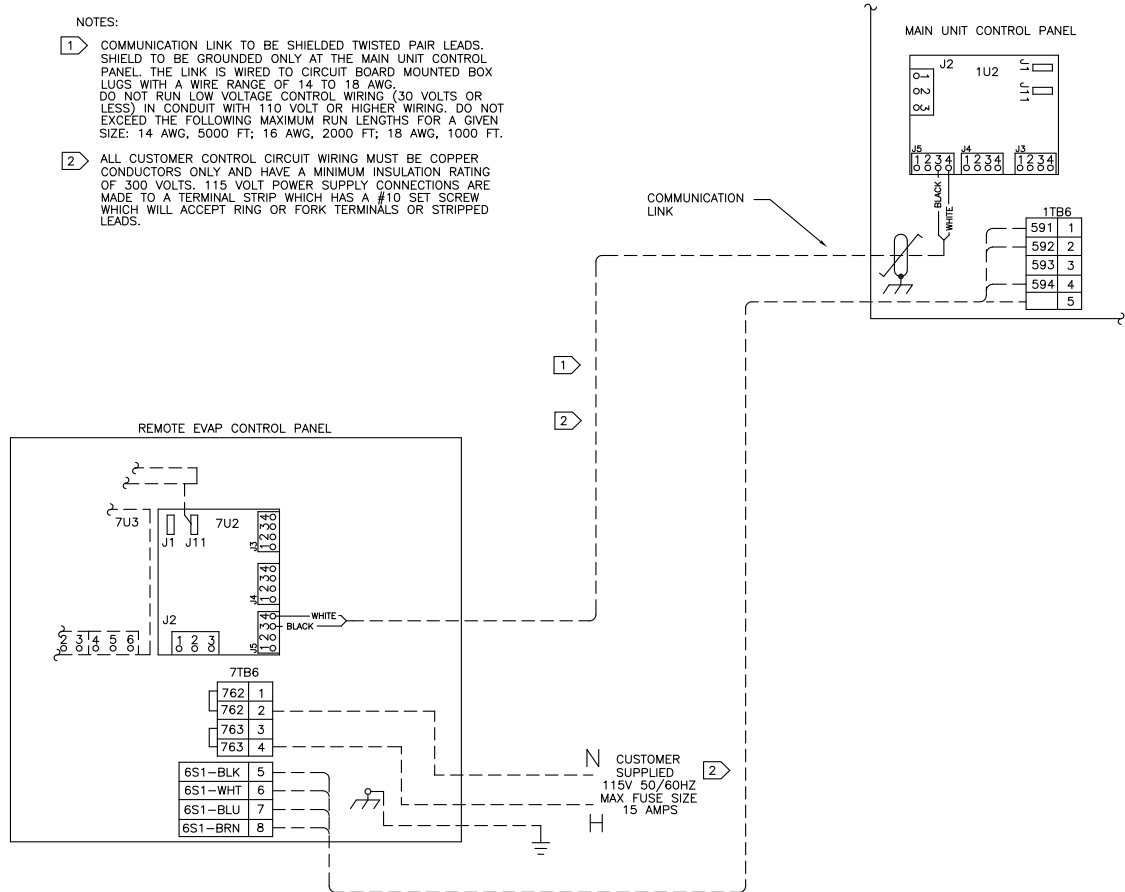

Figure 32. Field wiring between remote evaporator and condensing unit



Refrigerant and Additional Oil Charge

Refrigerant Charge Determination

The approximate amount of refrigerant charge required by the system must be determined by referring to [Table 49](#) and must be verified by running the system and checking subcooling.

Table 49. Field installed piping charge

Pipe O.D. (in)	Suction Line lbs of R134a per 100ft	Liquid Line lbs of R134a per 100ft
1-3/8	N/A	62.4
1-5/8	N/A	88.3
2-1/8	N/A	153.6
2-5/8	N/A	236.9
3-1/8	5.0	N/A
3-5/8	6.8	N/A
4-1/8	8.8	N/A

1. To determine the appropriate charge, first refer to the [Table 1, p. 10](#) through [Table 10, p. 19](#) in section "General Data," p. 9 to establish the required charge

without the field-installed piping.

2. Next, determine the charge required for the field-installed piping by referring to [Table 49, p. 64](#).
3. Sum the values of step 1 and step 2 to determine the circuit charge.

Note: The amounts of refrigerant listed in [Table 49, p. 64](#) are per 100 feet of pipe. Requirements will be in direct proportion to the actual length of piping.

Oil Charge Determination

The unit is factory charged with the amount of oil required by the system, without the field-installed piping. The amount of the additional oil required is dependent upon the amount of refrigerant that is added to the system for the field installed piping.

Use the following formula to calculate the amount of oil to be added:

Pints of Oil = [lbs of R-134a added for field-installed piping]/100



Installation - Electrical

General Recommendations

As you review this manual, keep in mind that:

- All field-installed wiring must conform to National Electric Code (NEC) guidelines, and any applicable state and local codes. Be sure to satisfy proper equipment grounding requirements per NEC.
- Compressor motor and unit electrical data (including minimum circuit ampacities, motor kW, voltage utilization range, rated load amps) is listed on the chiller nameplate.
- All field-installed wiring must be checked for proper terminations, and for possible shorts or grounds.

Note: Always refer to wiring diagrams shipped with chiller or unit submittal for specific electrical schematic and connection information.

⚠ WARNING

Proper Field Wiring and Grounding Required!

All field wiring **MUST** be performed by qualified personnel. Improperly installed and grounded field wiring poses **FIRE** and **ELECTROCUTION** hazards. To avoid these hazards, you **MUST** follow requirements for field wiring installation and grounding as described in NEC and your local/state electrical codes. Failure to follow code could result in death or serious injury.

⚠ WARNING

Hazardous Voltage!

Disconnect all electric power, including remote disconnects before servicing. Follow proper lockout/tagout procedures to ensure the power can not be inadvertently energized. Failure to disconnect power before servicing could result in death or serious injury.

NOTICE:

Use Copper Conductors Only!

Unit terminals are not designed to accept other types of conductors. Failure to use copper conductors could result in equipment damage.

Important: To prevent control malfunctions, do not run low voltage wiring (<30 V) in conduit with conductors carrying more than 30 volts.



Installer-Supplied Components

Customer wiring interface connections are shown in the electrical schematics and connection diagrams that are shipped with the unit. The installer must provide the following components if not ordered with the unit:

- Power supply wiring (in conduit) for all field-wired connections.
- All control (interconnecting) wiring (in conduit) for field supplied devices.
- Fused-disconnect switches or circuit breakers.
- Power factor correction capacitors. (optional)

Power Supply Wiring

All power supply wiring must be sized and selected accordingly by the project engineer in accordance with NECTable 310-16.

⚠ WARNING

Proper Field Wiring and Grounding Required!

All field wiring MUST be performed by qualified personnel. Improperly installed and grounded field wiring poses FIRE and ELECTROCUTION hazards. To avoid these hazards, you MUST follow requirements for field wiring installation and grounding as described in NEC and your local/state electrical codes. Failure to follow code could result in death or serious injury.

⚠ WARNING

Hazardous Voltage w/Capacitors!

Disconnect all electric power, including remote disconnects and discharge all motor start/run capacitors before servicing. Follow proper lockout/tagout procedures to ensure the power cannot be inadvertently energized. For variable frequency drives or other energy storing components provided by Trane or others, refer to the appropriate manufacturer's literature for allowable waiting periods for discharge of capacitors. Verify with an appropriate voltmeter that all capacitors have discharged. Failure to disconnect power and discharge capacitors before servicing could result in death or serious injury.

For additional information regarding the safe discharge of capacitors, see PROD-SVB06A-EN

All wiring must comply with local codes and the National Electrical Code. The installing (or electrical) contractor must provide and install the system interconnecting wiring, as well as the power supply wiring. It must be properly sized and equipped with the appropriate fused disconnect switches.

The type and installation location(s) of the fused disconnects must comply with all applicable codes.

NOTICE:

Use Copper Conductors Only!

Unit terminals are not designed to accept other types of conductors. Failure to use copper conductors could result in equipment damage.

Cut holes into the sides of the control panel for the appropriately-sized power wiring conduits. The wiring is passed through these conduits and connected to the terminal blocks, optional unit-mounted disconnects, or HACR type breakers. Refer to [Figure 33, p. 67](#).

To provide proper phasing of 3-phase input, make connections as shown in field wiring diagrams and as stated on the WARNING label in the starter panel. For additional information on proper phasing, refer to "Unit Voltage Phasing." Proper equipment ground must be provided to each ground connection in the panel (one for each customer-supplied conductor per phase).

All 115 volt field-provided connections (either control or power) are made through knockouts on the lower left side of the panel, as shown on [Figure 33](#). Additional grounds may be required for each 115 volt power supply to the unit. Green lugs are provided for 115V customer wiring.

Single Point Power on Dual Panel Units (Optional)

Units which require two control panels and with single point power option selected, are built with a power connection junction box located in the center of the unit as shown in [Figure 34, p. 67](#). Customer will connect to terminal blocks inside this panel.

Figure 33. Control panel

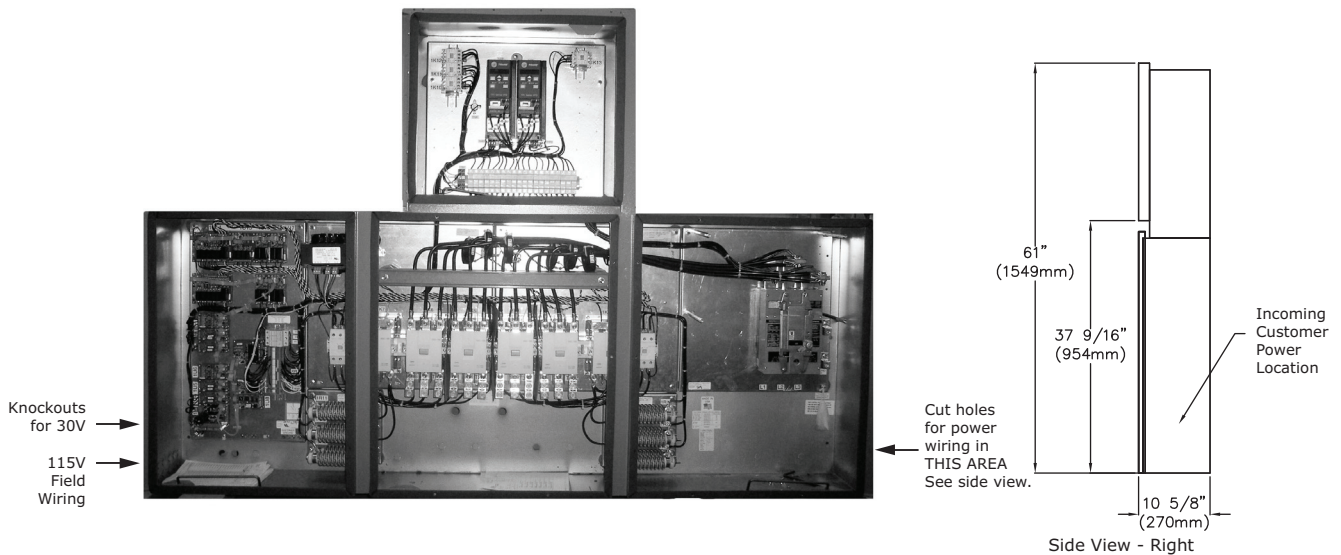
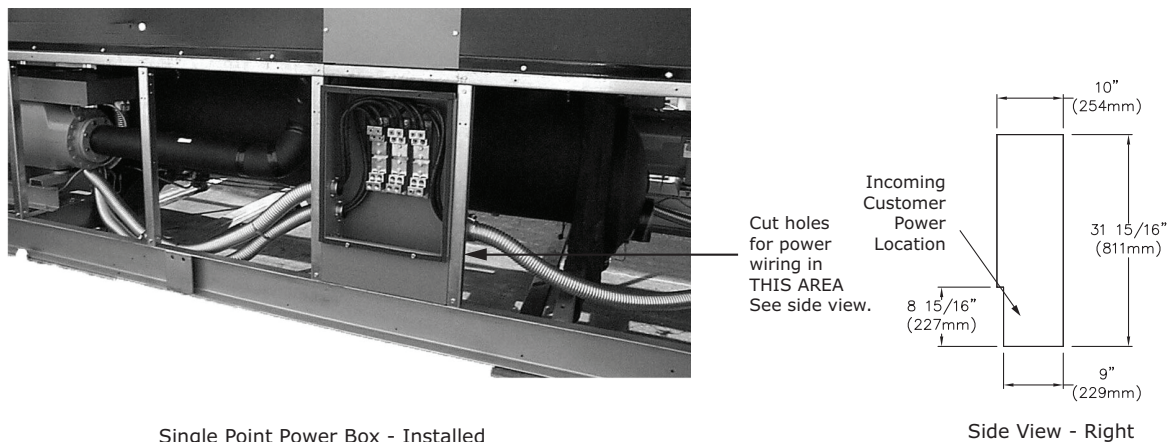

Figure 34. Single point power box - optional on dual panel units



Single Point Power Box - Installed

Control Power Supply

The unit is equipped with a control power transformer; it is not necessary to provide additional control power voltage to the unit.

All units are factory-connected for appropriate labeled voltages except for the 400V/50Hz units which need the control power transformer (1T1) reconnected as noted below.

Important: *As shipped, a normal 400 volt unit control power transformer is wired on the 400 volt tap (H3). Reconnect the appropriate transformer wire lead 126A to the tap (H2) for 380V/50Hz power supply or lead 126A to the tap H4 for the 415V/50 Hz power supply. It is also necessary to adjust the "unit voltage" setting using TechView (Configuration-Custom Tab).*

Heater Power Supply and Convenience Outlet (Packaged Units Only)

The evaporator shell is insulated from ambient air and protected from freezing temperatures by two thermostatically-controlled immersion heaters and two strip heaters. Whenever the water temperature drops to approximately 37°F (2.8°C), the thermostat energizes the heaters. The heaters will provide protection from ambient temperatures down to -20°F (-29°C).

It is required to provide an independent power source (115V 60Hz-20 amp, 220V 50Hz-15 amp), with a fused-disconnect. The heaters are factory-wired back to the unit control panel.

NOTICE:

Equipment Damage!

Control panel main processor does not check for loss of power to the heat tape nor does it verify thermostat operation. A qualified technician must verify power to the heat tape and confirm operation of the heat tape thermostat to avoid catastrophic damage to the evaporator.

A convenience outlet is also optional, which shares the same power supply as the heaters on 140-250 ton units. Be aware that when the heater is operating, the convenience outlet amperage draw will be reduced accordingly.

Note: *The convenience outlet is optional. The heaters are required.*

Interconnecting Wiring

Chilled Water Pump Control

An evaporator water pump output relay closes when the chiller is given a signal to go into the Auto mode of operation from any source. The contact is opened to turn off the pump in the event of most machine level diagnostics to prevent the build up of pump heat.

NOTICE:

Equipment Damage!

If insufficient concentration or no glycol is used, the evaporator water pumps must be controlled by the CH530 to avoid severe damage to the evaporator due to freezing. A power loss of 15 minutes during freezing can damage the evaporator. It is the responsibility of the installing contractor and/or the customer to ensure that a pump will start when called upon by the chiller controls.

Please consult [Table 42, p. 54](#) for correct concentration of glycol.

The warranty will be void, in case of freezing due to the lack of use of either of these protections.

The relay output from 1U10 is required to operate the Evaporator Water Pump (EWP) contactor. Contacts should be compatible with 115/240 VAC control circuit. The EWP relay operates in different modes depending on CH530 or Tracer commands, if available, or service pumpdown (See maintenance section). Normally, the EWP relay follows the AUTO mode of the chiller. Whenever the chiller has no diagnostics and is in the AUTO mode, regardless of where the auto command is coming from, the normally open relay is energized. When the chiller exits the AUTO mode, the relay is timed open for an adjustable (using TechView) 0 to 30 minutes. The non-AUTO modes in which the pump is stopped, include Reset (88), Stop (00), External Stop (100), Remote Display Stop (600), Stopped by Tracer (300),

Low Ambient Run Inhibit (200), and Ice Building complete (101).

Regardless of whether the chiller is allowed to control the pump on a full-time basis, if the MP calls for a pump to start and water does not flow, the evaporator may be damaged catastrophically. It is the responsibility of the installing contractor and/or the customer to ensure that a pump will start when called upon by the chiller controls.

Table 50. Pump Relay Operation

Chiller Mode	Relay Operation
Auto	Instant close
Ice Building	Instant close
Tracer Override	Close
Stop	Timed Open
Ice Complete	Instant Open
Diagnostics	Instant Open

Note: *Exceptions are listed below.*

When going from Stop to Auto, the EWP relay is energized immediately. If evaporator water flow is not established in 20 minutes (for normal transition) or 4 minutes, 15 seconds (for pump commanded ON due to an override safety), the CH530 de-energizes the EWP relay and generates a non-latching diagnostic. If flow returns (e.g. someone else is controlling the pump), the diagnostic is cleared, the EWP is re-energized, and normal control resumed.

If evaporator water flow is lost once it had been established, the EWP relay remains energized and a non-latching diagnostic is generated. If flow returns, the diagnostic is cleared and the chiller returns to normal operation.

In general, when there is either a non-latching or latching diagnostic, the EWP relay is turned off as though there was a zero time delay. Exceptions (see above table) whereby the relay continues to be energized occur with:

A Low Chilled Water Temp. diagnostic (non-latching) (unless also accompanied by an Evap Leaving Water Temperature Sensor Diagnostic)

or

A starter contactor interrupt failure diagnostic, in which a compressor continues to draw current even after commanded to have shutdown

or

A Loss of Evaporator Water Flow diagnostic (non-latching) and the unit is in the AUTO mode, after initially having proven evaporator water flow.

Alarm and Status Relay Outputs (Programmable Relays)

A programmable relay concept provides for enunciation of certain events or states of the chiller, selected from a list of

likely needs, while only using four physical output relays, as shown in the field wiring diagram. The four relays are provided (generally with a Quad Relay Output LLID) as part of the Alarm Relay Output Option. The relay's contacts are isolated Form C (SPDT), suitable for use with 120 VAC circuits drawing up to 2.8 amps inductive, 7.2 amps resistive, or 1/3 HP and for 240 VAC circuits drawing up to 0.5 amp resistive.

The list of events/states that can be assigned to the programmable relays can be found in Table 51. The relay will be energized when the event/state occurs.

Table 51. Alarm and Status Relay Output Configuration Table

	Description
Alarm - Latching	This output is true whenever there is any active diagnostic that requires a manual reset to clear, that affects either the Chiller, the Circuit, or any of the Compressors on a circuit. This classification does not include informational diagnostics.
Alarm - Auto Reset	This output is true whenever there is any active diagnostic that could automatically clear, that affects either the Chiller, the Circuit, or any of the Compressors on a circuit. This classification does not include informational diagnostics.
Alarm	This output is true whenever there is any diagnostic affecting any component, whether latching or automatically clearing. This classification does not include informational diagnostics
Alarm Ckt 1	This output is true whenever there is any diagnostic effecting Refrigerant Circuit 1, whether latching or automatically clearing, including diagnostics affecting the entire chiller. This classification does not include informational diagnostics.
Alarm Ckt 2	This output is true whenever there is any diagnostic affecting Refrigerant Circuit 2 whether latching or automatically clearing, including diagnostics effecting the entire chiller. This classification does not include informational diagnostics.
Chiller Limit Mode (with a 20 minute filter)	This output is true whenever the chiller has been running in one of the Unloading types of limit modes (Condenser, Evaporator, Current Limit or Phase Imbalance Limit) continuously for the last 20 minutes.
Circuit 1 Running	This output is true whenever any compressors are running (or commanded to be running) on Refrigerant Circuit 1, and false when no compressors are commanded to be running on that circuit.
Circuit 2 Running	This output is true whenever any compressors are running (or commanded to be running) on Refrigerant Circuit 2, and false when no compressors are commanded to be running on that circuit.
Chiller Running	This output is true whenever any compressors are running (or commanded to be running) on the chiller and false when no compressors are commanded to be running on the chiller.

Table 51. Alarm and Status Relay Output Configuration Table (continued)

	Description
Maximum Capacity (software 18.0 or later)	This output is true whenever the chiller has reached maximum capacity or had reached its maximum capacity and since that time has not fallen below 70% average current relative to the rated ARI current for the chiller. The output is false when the chiller falls below 70% average current and, since that time, had not reestablished maximum capacity.

Relay Assignments Using TechView

CH530 ServiceTool (TechView) is used to install the Alarm and Status Relay Option package and assign any of the above list of events or status to each of the four relays provided with the option. The relays to be programmed are referred to by the relay's terminal numbers on the LLID board 1U12.

The default assignments for the four available relays of the RTAC Alarm and Status Package Option are:

Table 52. Default assignments

Relay	
Relay 1 Terminals J2 -12,11,10:	Alarm
Relay 2 Terminals J2 - 9,8,7:	Chiller Running
Relay 3 Terminals J2-6,5,4:	Maximum Capacity
Relay 4 Terminals J2-3,2,1:	Chiller Limit

If any of the Alarm/Status relays are used, provide electrical power, 115 VAC with fused-disconnect to the panel and wire through the appropriate relays (terminals on 1U12 (EUR=A4-5)). Provide wiring (switched hot, neutral, and ground connections) to the remote annunciation devices. Do not use power from the chiller's control panel transformer to power these remote devices. Refer to the field diagrams which are shipped with the unit.

Low Voltage Wiring

The remote devices described below require low voltage wiring. All wiring to and from these remote input devices to the Control Panel must be made with shielded, twisted pair conductors. Be sure to ground the shielding only at the panel.

Important: *To prevent control malfunctions, do not run low voltage wiring (<30 V) in conduit with conductors carrying more than 30 volts.*

Emergency Stop

CH530 provides auxiliary control for a customer specified/ installed latching trip out. When this customer-furnished remote contact 5K14 is provided, the chiller will run normally when the contact is closed. When the contact opens, the unit will trip on a manually resettable



Installation - Electrical

diagnostic. This condition requires manual reset at the chiller switch on the front of the control panel.

Connect low voltage leads to terminal strip locations on 1U4. Refer to the field diagrams that are shipped with the unit.

Silver or gold-plated contacts are recommended. These customer-furnished contacts must be compatible with 24 VDC, 12 mA resistive load.

External Auto/Stop

If the unit requires the external Auto/Stop function, the installer must provide leads from the remote contacts 5K15 to the proper terminals of the LLID 1U4 on the control panel.

The chiller will run normally when the contacts are closed. When either contact opens, the compressor(s), if operating, will go to the RUN:UNLOAD operating mode and cycle off. Unit operation will be inhibited. Closure of the contacts will permit the unit to return to normal operation.

Field-supplied contacts for all low voltage connections must be compatible with dry circuit 24 VDC for a 12 mA resistive load. Refer to the field diagrams that are shipped with the unit.

External Circuit Lockout – Circuit #1 and #2

CH530 provides auxiliary control of a customer specified or installed contact closure, for individual operation of either Circuit #1 or #2. If the contact is closed, the refrigerant circuit will not operate 5K16 and 5K17.

Upon contact opening, the refrigerant circuit will run normally. This feature is used to restrict total chiller operation, e.g. during emergency generator operations.

Connections to 1U5 are shown in the field diagrams that are shipped with the unit.

These customer-supplied contact closures must be compatible with 24 VDC, 12 mA resistive load. Silver or gold plated contacts are recommended.

Ice Building Option

CH530 provides auxiliary control for a customer specified/ installed contact closure for ice building if so configured and enabled. This output is known as the Ice Building Status Relay. The normally open contact will be closed when ice building is in progress and open when ice building has been normally terminated either through Ice Termination setpoint being reached or removal of the Ice Building command. This output is for use with the ice storage system equipment or controls (provided by others) to signal the system changes required as the chiller mode changes from “ice building” to “ice complete”. When contact 5K18 is provided, the chiller will run normally when the contact is open.

CH530 will accept either an isolated contact closure (External Ice Building command) or a Remote

Communicated input (Tracer) to initiate and command the Ice Building mode.

CH530 also provides a “Front Panel Ice Termination Setpoint”, settable through TechView, and adjustable from 20 to 31°F (-6.7 to -0.5°C) in at least 1°F (1°C) increments.

Note: *When in the Ice Building mode, and the evaporator entering water temperature drops below the ice termination setpoint, the chiller terminates the Ice Building mode and changes to the Ice Building Complete Mode.*

NOTICE:

Equipment Damage!

Freeze inhibitor must be adequate for the leaving water temperature. Failure to do so will result in damage to system components.

Techview must also be used to enable or disable Ice Machine Control. This setting does not prevent the Tracer from commanding Ice Building mode.

Upon contact closure, the CH530 will initiate an ice building mode, in which the unit runs fully loaded at all times. Ice building shall be terminated either by opening the contact or based on the entering evaporator water temperature. CH530 will not permit the ice building mode to be reentered until the unit has been switched out of ice building mode (open 5K18 contacts) and then switched back into ice building mode (close 5K18 contacts.)

In ice building, all limits (freeze avoidance, evaporator, condenser, current) will be ignored. All safeties will be enforced.

If, while in ice building mode, the unit gets down to the freeze stat setting (water or refrigerant), the unit will shut down on a manually resettable diagnostic, just as in normal operation.

Connect leads from 5K18 to the proper terminals of 1U7. Refer to the field diagrams which are shipped with the unit.

Silver or gold-plated contacts are recommended. These customer furnished contacts must be compatible with 24 VDC, 12 mA resistive load.

External Chilled Water Setpoint (ECWS) Option

The CH530 provides inputs that accept either 4-20 mA or 2-10 VDC signals to set the external chilled water setpoint (ECWS). This is not a reset function. The input defines the set point. This input is primarily used with generic BAS (building automation systems). The chilled water setpoint set via the DynaView or through digital communication with Tracer (Comm3). The arbitration of the various chilled water setpoint sources is described in the flow charts at the end of the section.

The chilled water setpoint may be changed from a remote location by sending either a 2-10 VDC or 4-20 mA signal to the 1U6, terminals 5 and 6 LLID. 2-10 VDC and 4-20 mA

each correspond to a 10 to 65°F (-12 to 18°C) external chilled water setpoint.

The following equations apply:

	Voltage Signal	Current Signal
As generated from external source	$VDC=0.1455*(ECWS)+0.5454$	$mA=0.2909*(ECWS)+1.0909$
As processed by CH530	$ECWS=6.875*(VDC)-3.75$	$ECWS=3.4375*(mA)-3.75$

If the ECWS input develops an open or short, the LLID will report either a very high or very low value back to the main processor. This will generate an informational diagnostic and the unit will default to using the Front Panel (DynaView) Chilled Water Setpoint.

TechView ServiceTool is used to set the input signal type from the factory default of 2-10 VDC to that of 4-20 mA. TechView is also used to install or remove the External Chilled Water Setpoint option as well as a means to enable and disable ECWS.

External Current Limit Setpoint (ECLS) Option

Similar to the above, the CH530 also provides for an optional External Current Limit Setpoint that will accept either a 2-10 VDC (default) or a 4-20 mA signal. The Current Limit Setting can also be set via the DynaView or through digital communication with Tracer (Comm 3). The arbitration of the various sources of current limit is described in the flow charts at the end of this section. The External Current Limit Setpoint may be changed from a remote location by hooking up the analog input signal to the 1 U6 LLID terminals 2 and 3. Refer to the following paragraph on Analog Input Signal Wiring Details. The following equations apply for ECLS:

	Voltage Signal	Current Signal
As generated from external source	$VDC+0.133*(\%)-6.0$	$mA=0.266*(\%)-12.0$
As processed by UCM	$\%=7.5*(VDC)+45.0$	$\%=3.75*(mA)+45.0$

If the ECLS input develops an open or short, the LLID will report either a very high or very low value back to the main processor. This will generate an informational diagnostic and the unit will default to using the Front Panel (DynaView) Current Limit Setpoint.

The TechView ServiceTool must be used to set the input signal type from the factory default of 2-10 VDC to that of 4-20 mA current. TechView must be also be used to install or remove the External Current Limit Setpoint Option for field installation, or can be used to enable or disable the feature (if installed).

ECLS and ECWS Analog Input Signal Wiring Details:

Both the ECWS and ECLS can be connected and setup as either a 2-10 VDC (factory default), 4-20 mA, or resistance input (also a form of 4-20mA) as indicated below.

Depending on the type to be used, the TechView Service Tool must be used to configure the LLID and the MP for the proper input type that is being used. This is accomplished by a setting change on the Custom Tab of the Configuration View within TechView.

Important: For proper unit operation, BOTH ECLS and ECWS settings MUST be the same (2-10 VDC or 4-20mA), even if only one input is to be used.

The J2-3 and J2-6 terminal is chassis grounded and terminal J2- 1 and J2-4 can be used to source 12 VDC. The ECLS uses terminals J2-2 and J2-3. ECWS uses terminals J2-5 and J2-6. Both inputs are only compatible with high-side current sources.

Figure 35. Wiring examples for ECLS and ECWS

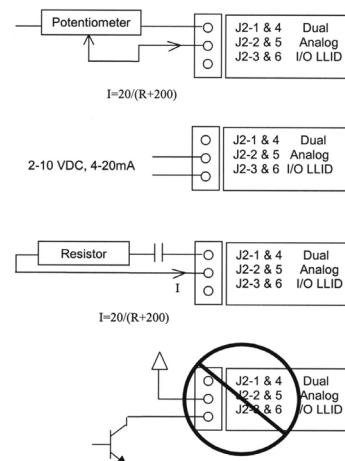

Chilled Water Reset (CWR)

CH530 resets chilled water temperature set point based on either return water temperature, or outdoor air temperature. Return Reset and Outdoor Reset are standard. The following shall be selectable:

- One of three Reset Types: None, Return Water Temperature Reset, Outdoor Air Temperature Reset, or Constant Return Water Temperature Reset.
- Reset Ratio Set Points.
For outdoor air temperature reset there shall be both positive and negative reset ratio's.
- Start Reset Set Points.
- Maximum Reset Set Points.

The equations for each type of reset are as follows:

Return

$$CWS' = CWS + \text{RATIO} (\text{START RESET} - (\text{TWE} - \text{TWL}))$$

$$\text{and } CWS' > \text{ or } = CWS$$

$$\text{and } CWS' - CWS < \text{ or } = \text{Maximum Reset}$$

Outdoor

$$CWS' = CWS + \text{RATIO} * (\text{START RESET} - \text{TOD})$$

$$\text{and } CWS' > \text{ or } = CWS$$



Installation - Electrical

and $CWS' - CWS < \text{or} = \text{Maximum Reset}$

where

CWS' is the new chilled water set point or the "reset CWS "

CWS is the active chilled water set point before any reset has occurred, e.g. normally Front Panel, Tracer, or ECWS

RESET RATIO is a user adjustable gain

START RESET is a user adjustable reference

TOD is the outdoor temperature

TWE is entering evap. water temperature

TWL is leaving evap. water temperature

MAXIMUM RESET is a user adjustable limit providing the maximum amount of reset. For all types of reset, $CWS' - CWS < \text{or} = \text{Maximum Reset}$.

Reset Type	Range		Increment			Factory Default
	Reset Ratio	Start Reset	Max Reset	IP Units	SI Units	
Return	10 to 120%	4 to 30 F (2.2 to 16.7 C)	0 to 20 F (0.0 to 11.1 C)	1%	1%	50%
Outdoor	80 to -80%	50 to 130 F (10 to 54.4 C)	0 to 20 F (0.0 to 11.1 C)	1%	1%	10%

In addition to Return and Outdoor Reset, the MP provides a menu item for the operator to select a Constant Return Reset. Constant Return Reset will reset the leaving water temperature set point so as to provide a constant entering water temperature. The Constant Return Reset equation is the same as the Return Reset equation except on selection of Constant Return Reset, the MP will automatically set Ratio, Start Reset, and Maximum Reset to the following.

RATIO = 100%

START RESET = Design Delta Temp.

MAXIMUM RESET = Design Delta Temp.

The equation for Constant Return is then as follows:

$CWS' = CWS + 100\% (\text{Design Delta Temp.} - (TWE - TWL))$
and $CWS' > \text{or} = CWS$

and $CWS' - CWS < \text{or} = \text{Maximum Reset}$

When any type of CWR is enabled, the MP will step the Active CWS toward the desired CWS' (based on the above equations and setup parameters) at a rate of 1 degree F every 5 minutes until the Active CWS equals the desired CWS' . This applies when the chiller is running.

When the chiller is not running, CWS is reset immediately (within one minute) for Return Reset and at a rate of 1 degree F every 5 minutes for Outdoor Reset. The chiller will start at the Differential to Start value above a fully reset CWS or CWS' for both Return and Outdoor Reset.

Communications Interface Options

Tracer Communications Interface Option

This option allows the Tracer CH530 controller to exchange information (e.g. operating setpoints and Auto/Standby commands) with a higher-level control device, such as a Tracer Summit or a multiple-machine controller. A shielded, twisted pair connection establishes the bi-directional communications link between the Tracer CH530 and the building automation system.

Important: To prevent control malfunctions, do not run low voltage wiring (<30 V) in conduit with conductors carrying more than 30 volts.

Field wiring for the communication link must meet the following requirements:

- All wiring must be in accordance with the NEC and local codes.
- Communication link wiring must be shielded, twisted pair wiring (Belden 8760 or equivalent). See the table below for wire size selection:

Table 53. Wire Size

Wire Size	Maximum Length of Communication Wire
14 AWG (2.5 mm ²)	5,000 FT (1525 m)
16 AWG (1.5 mm ²)	2,000 FT (610 m)
18 AWG (1.0 mm ²)	1,000 FT (305 m)

- The communication link cannot pass between buildings.
- All units on the communication link can be connected in a "daisy chain" configuration.

LonTalk™ Interface (LCI-C)

CH530 provides an optional LonTalk Communication Interface (LCI-C) between the chiller and a Building Automation System (BAS). An LCI-C LLID shall be used to provide "gateway" functionality between a LonTalk compatible device and the Chiller. The inputs/outputs include both mandatory and optional network variables as established by the LonMark® Functional Chiller Profile 8040.

Note: For more information, see ACC-SVN25*-EN.

BACnet™ Interface (BCI-C)

Optional BACnet Communication Interface for Chillers (BCI-C) is comprised of a Tracer UC400 controller with interface software. It is a non-programmable communications module that allows units to communicate on a BACnet communications network.

Note: For more information, see BAS-SVP05*-EN.



Operating Principles

This section contains an overview of the operation and maintenance of RTAC units equipped with CH530 control systems. It describes the overall operating principles of the RTAC design.

Refrigeration Cycle

The refrigeration cycle of the RTAC chiller is similar to that of the RTAA air cooled water chiller. The exception is that the evaporating and condensing temperatures have been increased to allow for optimization of the chiller and reduced foot print. The refrigeration cycle is represented in the pressure enthalpy diagram in Figure 36. Key state points are indicated on the figure. The cycle for the full load AHRI design point is represented in the plot.

Figure 36. Pressure enthalpy (P-h) diagram - RTAC

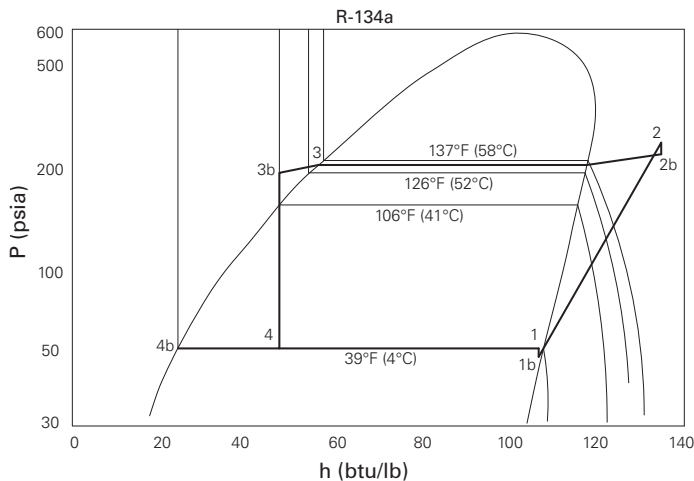

The RTAC chiller uses a shell and tube evaporator design with refrigerant evaporating on the shell side and water flowing inside tubes having enhanced surfaces (states 4 to 1). The suction lines and bolt pads are designed to minimize pressure drop. (states 1 to 1b). The compressor is a twin-rotor helical rotary compressor designed similarly to the compressors offered in other Trane Screw Compressor Based Chillers (states 1b to 2). The discharge lines include a highly efficient oil separation system that virtually removes all oil from the refrigerant stream going to the heat exchangers (states 2 to 2b). De-superheating, condensing and sub-cooling is accomplished in a fin and tube air cooled heat exchanger where refrigerant is condensed in the tube (states 2b to 3b). Refrigerant flow through the system is balanced by an electronic expansion valve (states 3b to 4).

Refrigerant R-134a

The RTAC chiller uses environmentally friendly R134a. Trane believes that responsible refrigerant practices are important to the environment, our customers, and the air conditioning industry. All technicians who handle

refrigerants must be certified. The Federal Clean Air Act (Section 608) sets forth the requirements for handling, reclaiming, recovering and recycling of certain refrigerants and the equipment that is used in these service procedures. In addition, some states or municipalities may have additional requirements that must also be adhered to for responsible management of refrigerants. Know the applicable laws and follow them.

R-134a is a medium pressure refrigerant. It may not be used in any condition that would cause the chiller to operate in a vacuum without a purge system. RTAC is not equipped with a purge system. Therefore, the RTAC chiller may not be operated in a condition that would result in a saturated condition in the chiller of -15°F (-26°C) or lower.

R-134a requires the use of specific POE oils as designated on the unit nameplate.

Important: Use only R-134a and Trane Oil 00048 in RTAC chillers.

Compressor

The compressor is a semi-hermetic, direct-drive rotary type compressor. Each compressor has only four moving parts: two rotors that provide compression and male and female load-control valves. The male rotor is attached to the motor and the female rotor is driven by the male rotor. The rotors and motor are supported by bearings.

The helical rotary compressor is a positive displacement device. Refrigerant vapor from evaporator is drawn into the suction opening of the compressor (state 1b), through a suction strainer screen across the motor (which provides motor cooling) and into the intake of the compressor rotors. The gas is then compressed and discharged through a check valve and into the discharge line (state 2).

There is no physical contact between the rotors and the compressor housing. The rotors contact each other at the point where the driving action between the male and female rotors occurs. Oil is injected into the rotors of the compressor, coating the rotors and the compressor housing interior. Although this oil does provide rotor lubrication, its primary purpose is to seal the clearance spaces between the rotors and compressor housing. A positive seal between these internal parts enhances compressor efficiency by limiting leakage between the high pressure and low pressure cavities.

Capacity control is accomplished by means of a female step load-control valve and a male control valve. The female step valve is the first stage of loading after the compressor starts and the last stage of unloading before the compressor shuts down. The male control valve is positioned by a piston cylinder along the length of the male rotor. Compressor capacity is dictated by the position of the loading valve relative to the rotors. When the valve slides toward the discharge end of the rotors compressor capacity is reduced.



Condenser and Subcooler

Condenser and subcooler are similar to the condenser used in RTAA chillers. The heat exchanger consists of 3/8" tubes that contain refrigerant, large fins that are in the air flow and fans that draw air through fins. Heat is transferred from the refrigerant through the tubes and fins to the air.

High pressure gas from the compressor enters the tubes of the condenser through a distribution header (state 2b). As refrigerant flows through the tubes, the heat of compression and cooling load are rejected to the air. In this process the refrigerant is de-superheated, condensed (states 2b to 3) and finally subcooled (states 3 to 3b) to a temperature slightly above the ambient air temperature. The subcooled liquid refrigerant is collected in the leaving header where it is transferred to the liquid line (state 3b).

Controls algorithm always runs as many fans as possible without reducing differential pressure (discharge minus suction) below setpoint, 60 psid (4.2 bar). If a warm enough ambient is sensed, all fans will run. If ambient is cooler, some fans are shut off to maintain pressure differential. Fan staging depends on chiller load, evaporator pressure, condenser effectiveness, ambient temperature, and numbers and sizes of fans installed on circuit.

Algorithm pre-starts fans (based on ambient and water temperatures) when a circuit starts the compressor. (For rare conditions such as during some pull-downs, a steady fan state would either violate the 60 psid (4.2 bar) setpoint or cause a high pressure cut-out; in those conditions a fan will cycle on and off.)

For up to two minutes after chiller start-up, the setpoint is 35 psi (2.45 bar) difference, and then before the controls adjust gradually over half a minute up to 60 psi (4.2 bar).

Expansion Valve

Pressure drop occurs in an electronic expansion valve. The unit controller (CH530) uses the valve to regulate the flow through the liquid line to match the flow produced by the compressor. The valve has a variable orifice that is modulated by a stepper motor.

High pressure, subcooled liquid refrigerant enters the expansion valve from the liquid line. As refrigerant passes through the valve the pressure is dropped substantially, which results in vaporization of some of the refrigerant. The heat of vaporization is supplied by the two phase mixture resulting in low temperature low pressure refrigerant which is supplied to the evaporator (state 4) to provide cooling.

Evaporator

The evaporator is composed of a liquid-vapor distributor and falling film evaporator.

A liquid-vapor refrigerant mixture enters the distributor (state 4). The mixture is distributed over the length of the evaporator tubes (state 4b). Liquid is evenly distributed

over the length of the evaporator tubes by the two-phase distribution system. A portion of the liquid boils as it falls by gravity from tube to tube, wetting all the tubes of the evaporator. To ensure that the tubes at the bottom of the evaporator do not experience "dry out," a liquid pool is maintained in the bottom few inches of the bundle. Tubes located in the bottom of the evaporator will evaporate the liquid refrigerant by boiling (pool boiling).

Heat is transferred from the water or glycol inside the tubes to the liquid refrigerant as the film of refrigerant evaporates on the surface of the tube. Thin film heat transfer requires a smaller temperature difference for a given amount of heat transfer than nucleate boiling, which is the heat transfer process used in flooded evaporators. Hence, efficiency is enhanced by the use of falling film evaporation. Additionally, the evaporator requires less refrigerant than a comparable flooded evaporator and the evaporator boils the entire refrigerant supply at constant pressure. Refrigerant vapor exits the evaporator through the suction line (state 1).

Oil System

Screw compressors require large quantities of oil for lubricating and sealing the rotors and lubricating the bearings. This oil is mixed with refrigerant at the discharge of the compressor. To enhance the performance of the heat exchanger surfaces an oil separation system is placed into the discharge line. The oil separator is located between the compressor and the condenser. It separates oil using highly efficient centrifugal force. Approximately 99.5% of the oil is removed from the refrigerant in the separator.

Oil that is removed from the refrigerant falls by gravity into the oil sump. This oil is directed back to the compressor through the oil lines. Internal to the compressor is a high efficiency filter to clean the oil before it is delivered to the rotors and bearings. Once oil is injected into the compressor rotors it mixes with the refrigerant again and is delivered back to the discharge line.

Oil that gets past the oil separators flows through the condenser, subcooler and expansion valve into the evaporator. This oil is collected in the pool of refrigerant that is maintained in the bottom of the evaporator. A small amount of oil and refrigerant from this pool (state 4b) is returned through a line that is connected to the compressor down stream of the motor. This oil and refrigerant mixes with the refrigerant vapor that was drawn out of the evaporator, prior to injection into the compressor rotors.



Controls Interface

Overview

RTAC units utilize the Tracer™ CH530 chiller control system which consists of several elements:

- The main processor collects data, status, and diagnostic information and communicates commands to the starter module and the LLID (for Low Level Intelligent Device) bus. The main processor has an integral display (DynaView™).
- Higher level modules (e.g. starter) exist only as necessary to support system level control and communications. The starter module provides control of the starter when starting, running, and stopping the chiller motor. It also processes its own diagnostics and provides motor and compressor protection.
- Low level intelligent device (LLID) bus. The main processor communicates to each input and output device (e.g. temperature and pressure sensors, low voltage binary inputs, analog input/output) all connected to a four-wire bus, rather than the conventional control architecture of signal wires for each device.
- The communication interface to a building automation system (BAS).
- A service tool to provide all service/maintenance capabilities.

Main processor and service tool (™) software is downloadable from www.Trane.com. The process is discussed in section “TechView,” p. 83.

DynaView provides bus management. It has the task of restarting the link, or filling in for what it sees as “missing” devices when normal communications has been degraded. Use of TechView may be required.

The CH530 uses the IPC3 protocol based on RS485 signal technology and communicating at 19.2 Kbaud to allow 3 rounds of data per second on a 64-device network. A typical four-compressor RTAC will have around 50 devices.

Most diagnostics are handled by the DynaView. If a temperature or pressure is reported out of range by a LLID, the DynaView processes this information and calls out the diagnostic. The individual LLIDs are not responsible for any diagnostic functions. The only exception to this is the Starter module.

Note: *It is imperative that the CH530 Service Tool (TechView) be used to facilitate the replacement of any LLID or reconfigure any chiller component. TechView is discussed later in this section.*

Controls Interface

Each chiller is equipped with a DynaView interface. The DynaView has the capability to display information to the operator including the ability to adjust settings. Multiple screens are available and text is presented in multiple

languages as factory-ordered or can be easily downloaded from www.trane.com.

TechView can be connected to either the DynaView module and provides further data, adjustment capabilities, diagnostics information using downloadable software.

DynaView Display

DynaView™ display interface is made of weatherproof and durable plastic for use as a stand-alone device on the outside of the unit or mounted nearby. See Figure 37.

The DynaView uses a 1/4 VGA display with a resistive touch screen and an LED backlight. The display area is approximately 4 inches wide by 3 inches high (102mm x 60mm).

Figure 37. DynaView



Key Functions

In this touch screen application, key functions are determined completely by software and change depending upon the subject matter currently being displayed. The basic touch screen functions are outlined below.

Radio Buttons

Radio buttons show one menu choice among two or more alternatives, all visible. (It is the AUTO button in Figure 37.) The radio button model mimics the buttons used on old-fashioned radios to select stations. When one is pressed, the one that was previously pressed “pops out” and the new station is selected. In the DynaView model the possible selections are each associated with a button. The selected button is darkened, presented in reverse video to indicate it is the selected choice. The full range of possible choices as well as the current choice is always in view.

Spin Value Buttons

Spin values are used to allow a variable setpoint to be changed, such as leaving water setpoint. The value increases or decreases by touching the increment (+) or decrement (-) arrows.

Action Buttons

Action buttons appear temporarily and provide the user with a choice such as **Enter** or **Cancel**.

Hot Links

Hot links are used to navigate from one view to another view.

File Folder Tabs

File folder tabs are used to select a screen of data. Just like tabs in a file folder, these serve to title the folder/screen selected, as well as provide navigation to other screens. In DynaView, the tabs are in one row across the top of the display. The folder tabs are separated from the rest of the display by a horizontal line. Vertical lines separate the tabs from each other. The folder that is selected has no horizontal line under its tab, thereby making it look like a part of the current folder (as would an open folder in a file cabinet). The user selects a screen of information by touching the appropriate tab.

Display Screens

Note: Screens shown in this chapter are representative samples only, and may not exactly match the values, selections found on your particular unit.

Basic Screen Format

The basic screen format appears as

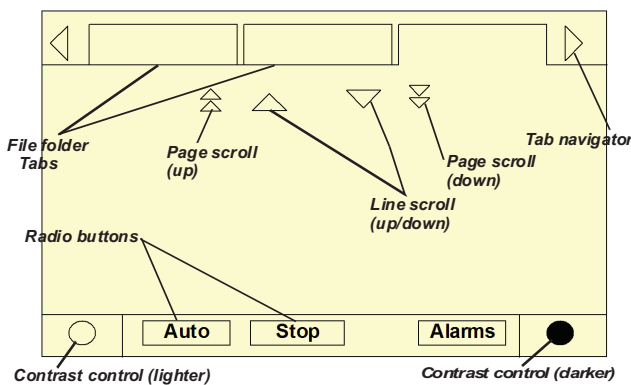

The file folder tabs across the top of the screen are used to select the various display screens.

Scroll arrows are added if more file tabs (choices) are available. When the tabs are at the left most position, the left navigator will not show and only navigation to the right will be possible. Likewise when the right most screen is selected, only left navigation will be possible.

The main body of the screen is used for description text, data, setpoints, or keys (touch sensitive areas). The Chiller Mode is displayed here.

The double up arrows cause a page-by-page scroll either up or down. The single arrow causes a line by line scroll to occur. At the end of the page, the appropriate scroll bar will disappear.

A double arrow pointing to the right indicates more information is available about the specific item on that same line. Pressing it will bring you to a subscreen that will present the information or allow changes to settings.

The bottom of the screen (Fixed Display) is present in all screens and contains the following functions. The **left circular area** is used to reduce the contrast/viewing angle of the display. The **right circular area** is used to increase the contrast/viewing angle of the display. The contrast may require re-adjustment at ambient temperatures significantly different from those present at last adjustment.

The other functions are critical to machine operation. The AUTO and STOP keys are used to enable or disable the chiller. The key selected is in black (reverse video). The chiller will stop when the STOP key is touched and after completing the Run Unload mode.

Touching the AUTO key will enable the chiller for active cooling if no diagnostic is present. (A separate action must be taken to clear active diagnostics.)

The AUTO and STOP keys, take precedence over the Enter and Cancel keys. (While a setting is being changed, AUTO and STOP keys are recognized even if Enter or Cancel has not been pressed.)

The ALARMS button appears only when an alarm is present, and blinks (by alternating between normal and reverse video) to draw attention to a diagnostic condition. Pressing the ALARMS button takes you to the corresponding tab for additional information.

Front Panel Lockout Feature

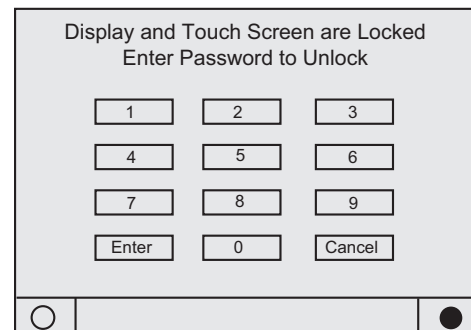

Note: The DynaView display and Touch Screen Lock screen is shown below. This screen is used if the Display and touch screen and lock feature is enabled. Thirty minutes after the last keystroke, this screen is displayed and the Display and Touch Screen is locked out until the sequence "159 <ENTER>" is pressed.

Until the proper password is entered, there will be no access to the DynaView screens including all reports, setpoints, and Auto/Stop/Alarms/Interlocks.

The password "159" is not programmable from either DynaView or TechView.

Front Panel Display During Cold Ambients

If the Display and Touch Screen Lock feature is disabled, the following screen is automatically displayed if the DynaView Temperature is below freezing and has been 30 minutes after the last keystroke.

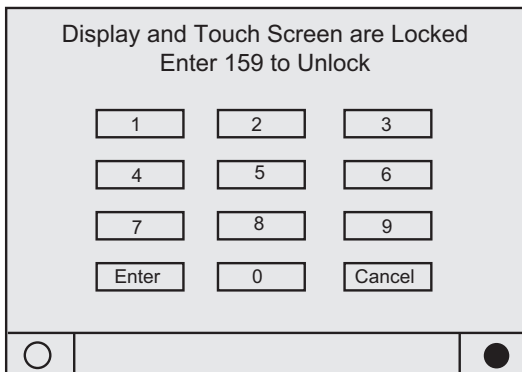

Note: This feature is provided to avoid unintended actuations of the keypad, which can occur due to ice build-up on the DynaView's exterior surfaces. Also be aware that at extremes of temperatures, the LCD display screen will change its contrast from the optimal adjustment made at more normal temperatures. It can appear washed out or blacked out. Simply pressing the lower right contrast

control on the screen will return the display to readable condition.

Note: All screens shown in this section are typical. Some screens show all display options available, only one of which may appear on a line.

Modes Screen

The Mode Screen is only found on software revisions 18 and later. This screen provides a display for the top level operating mode for each of the components and sub-components of the chiller (i.e. Chiller, Circuits, and Compressors) that exist on the Chiller as it is configured. The modes are displayed as text only without the hex codes.

In software revisions 17.0 and earlier, the top level mode and the sub mode for each component was displayed on the respective component tab on the first two lines. The mode display of the first three lines of the Compressor and Chiller Screen tabs is eliminated with the addition of the Mode Screen

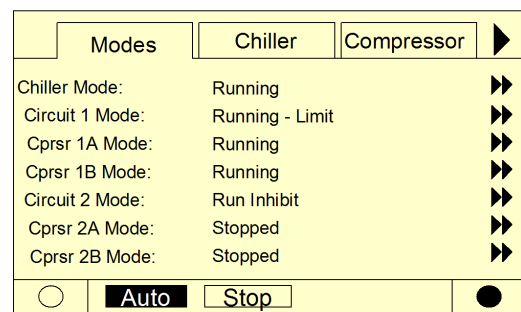

Table 54. Chiller modes

Chiller Modes	Description
Top Level Mode	
Sub-modes	
Stopped	The chiller is not running and cannot run without intervention. Further information is provided by the sub-mode:
Local Stop	Chiller is stopped by DynaView Stop button command- cannot be remotely overridden.
Panic Stop	Chiller is stopped by the DynaView Panic Stop (by pressing Stop button twice in succession) - previous shutdown was manually commanded to shutdown immediately without a run-unload or pumpdown cycle - cannot be remotely overridden.
Diagnostic Shutdown - Manual Reset	The chiller is stopped by a diagnostic that requires manual intervention to reset.
Other sub-modes are possible in conjunction with at least one of the above modes - See items below for their descriptions:	
Diagnostic Shutdown - Auto Reset	
Start Inhibited by Low Cond Temp	
Start Inhibited by Low Ambient Temp	
Start Inhibited by External Source	
Start Inhibited by BAS	
Waiting for BAS Communications	
Ice Building to Normal Transition	
Ice Building is Complete	
Run Inhibit	The chiller is currently being inhibited from starting (and running), but may be allowed to start if the inhibiting or diagnostic condition is cleared. Further information is provided by the sub-mode:
Diagnostic Shutdown - Auto Reset	The entire chiller is stopped by a diagnostic that may automatically clear.



Controls Interface

Table 54. Chiller modes (continued)

Chiller Modes	Description
Top Level Mode	
Sub-modes	
Start Inhibited by Low Cond Temp	The chiller is inhibited from starting by Low Condenser Temperature- Inhibit is active below either 25°F (can be disabled with proper freeze protection) or 0°F (limit set by design, cannot be disabled). As an exception, this will not stop a chiller already running.
Start Inhibited by Low Ambient Temp	The chiller is inhibited from starting (and running) by an outdoor air ambient temperature lower than a specified temperature - per user adjustable settings and can be disabled.
Start Inhibited by External Source	The chiller is inhibited from starting (and running) by the "external stop" hardwired input.
Start Inhibited by BAS	The chiller is inhibited from starting (and running) by command from a Building Automation System via the digital communication link (com 3 or com 5).
Waiting for BAS Communications	This is a transient mode - 15-min. max, and is only possible if the chiller is in the Auto - Remote command mode. After a power up reset, it is necessary to wait for valid communication from a Building Automation System (Tracer) to know whether to run or stay inhibited. Either valid communication will be received from the Building Automation System (e.g. Tracer), or a communication diagnostic ultimately will result. In the latter case the chiller will revert to Local control.
Ice Building to Normal Transition	The chiller is inhibited from running for a brief period of time if it is commanded from active ice building mode into normal cooling mode via the ice building hardwired input or Tracer. This allows time for the external system load to "switchover" from an ice bank to the chilled water loop, and provides for a controlled pull down of the loop's warmer temperature. This mode is not seen if the ice making is automatically terminated on return brine temperature per the mode below.
Ice Building is Complete	The chiller is inhibited from running as the Ice Building process has been normally terminated on the return brine temperature. The chiller will not start unless the ice building command (hardwired input or Building Automation System command) is removed or cycled.
Auto	The chiller is not currently running but can be expected to start at any moment given that the proper conditions and interlocks are satisfied. Further information is provided by the sub-mode:
Waiting For Evap Water Flow	The chiller will wait up to 4 minutes in this mode for evaporator water flow to be established per the flow switch hardwired input.
Waiting for Need to Cool	The chiller will wait indefinitely in this mode, for an evaporator leaving water temperature higher than the Chilled Water Setpoint plus the Differential to Start.
Starting	The chiller is going through the necessary steps to allow the lead circuit and lead compressor to start.
No Sub Modes	
Running	At least one circuit and one compressor on the chiller are currently running. Further information is provided by the sub-mode:
Unit is Building Ice	The chiller is running in the Ice Building Mode, and either at or moving towards full capacity available. Ice mode is terminated either with the removal of the ice mode command or with the return brine temperature falling below the Ice Termination Setpoint.
Running - Limited	At least one circuit and one compressor on the chiller are currently running, but the operation of the chiller as a whole is being actively limited by the controls.
Capacity Limited by High Evap Water Temp	This mode will occur if both the OA temperature is above 40°F and the Evap Leaving Water Temperature is above 75°F as is often the case in a high temperature pull-down. While in this mode, no compressors will be allowed to load past their minimum load capacity step, but it will not inhibit compressor staging. This mode is necessary to prevent nuisance trips due to Compressor Overcurrent or High Pressure Cutout. Reasonable pull-down rates can still be expected despite this limit.

Table 55. Circuit modes

Circuit Modes	Description
Top Level Mode	
Sub-modes	
Stopped	The given circuit is not running and cannot run without intervention. Further information is provided by the sub-mode:
Front Panel Lockout	The circuit is manually locked out by the circuit lockout setting - the nonvolatile lockout setting is accessible through either the DynaView or TechView.
Diagnostic Shutdown - Manual Reset	The circuit has been shutdown on a latching diagnostic.
Other sub-modes are possible in conjunction with at least one of the above modes - See items below for their descriptions: Diagnostic Shutdown - Auto Reset Start Inhibited by External Source Start Inhibited by BAS	
Run Inhibit	The given circuit is currently being inhibited from starting (and running), but may be allowed to start if the inhibiting or diagnostic condition is cleared. Further information is provided by the sub-mode:
Diagnostic Shutdown - Auto Reset	The circuit has been shutdown on a diagnostic that may clear automatically.
Start Inhibited by External Source	The circuit is inhibited from starting (and running) by its "external circuit lockout" hardwired input.
Start Inhibited by BAS	The circuit is inhibited from starting (and running) by command from a Building Automation System via the digital communication link (com 3 or com 5).
Auto	The given circuit is not currently running but can be expected to start at any moment given that the proper conditions and interlocks are satisfied.
No Sub Modes	
Starting	The given circuit is going through the necessary steps to allow the lead compressor on that circuit to start.
No Sub Modes	
Running	At least one compressor on the given circuit is currently running. Further information is provided by the sub-mode:
Establishing Min. Cap - Low Diff pressure	Circuit is experiencing low system differential pressure and is being force loaded, regardless of Chilled Water Temperature Control, to develop pressure sooner.
Running - Limited	At least one compressor on the given circuit is currently running, but the capacity of the circuit is being actively limited by the controls. Further information is provided by the sub-mode:
Capacity Limited by High Cond Press	Circuit is experiencing condenser pressures at or near the condenser limit setting. Compressors on circuit will be unloaded to prevent exceeding limits.
Capacity Limited by Low Evap Rfqt Temp	The circuit is experiencing saturated evaporator temperatures at or near the Low Refrigerant Temperature Cutout setting. Compressors on the circuit will be unloaded to prevent tripping.
Capacity Limited by Low Liquid Level	The circuit is experiencing low refrigerant liquid levels and the EXV is at or near full open. The compressors on the circuit will be unloaded to prevent tripping.
Shutting Down	The given circuit is still running but shutdown is imminent. The circuit is going through either a compressor run-unload mode or a circuit operational pumpdown to dry out the evaporator (cold OA ambient only). Shutdown is necessary due to one (or more) of the following sub-modes:
Operational Pumpdown	The circuit is in the process shutting down by performing an operational pumpdown just prior to stopping the last running compressor. The EXV is commanded closed. Pumpdown will terminate when both the liquid level and the evap pressure
Front Panel Lockout	The circuit has been manually locked out by the circuit lockout setting and is in the process of shutting down - the nonvolatile lockout setting is accessible through either the DynaView or TechView.
Diagnostic Shutdown - Manual Reset	The circuit is in the process of shutdown due to a latching diagnostic.
Diagnostic Shutdown - Auto Reset	The circuit is in the process of shutdown due to a diagnostic that may automatically clear.
Start Inhibited by External Source	The circuit is in the process of shutdown due to a command from the external circuit lockout hardwired input.
Start Inhibited by BAS	The circuit is in the process of shutdown due to a command from the Building Automation System (e.g. Tracer)



Controls Interface

Table 55. Circuit modes (continued)

Circuit Modes	Description
Top Level Mode	
Sub-modes	
Service Override	The given circuit is in a Service Override mode
Service Pumpdown	The circuit is running with fan control, via a manual command to perform a Service Pumpdown. Its respective EXV is being held wide open, but the manual liquid line service valve should be closed.

Table 56. Compressor modes

Compressor Modes	Description
Top Level Mode	
Sub-modes	
Stopped	The given compressor is not running and cannot run without intervention. Further information is provided by the sub-mode:
Diagnostic Shutdown - Manual Reset	The compressor has been shutdown on a latching diagnostic.
Service Tool Lockout	The compressor has been shutdown due to a command from the TechView Service Tool to be "locked out" and inoperative. This setting is nonvolatile and operation can only be restored by using TechView to "unlock" it.
Other sub-modes are possible in conjunction with at least one of the above modes - See items below for their descriptions:	
Diagnostic Shutdown - Auto Reset	
Restart Inhibit	
Run Inhibit	The given compressor is currently being inhibited from starting (and running*), but may be allowed to start if the inhibiting or diagnostic condition is cleared. Further information is provided by the sub-mode:
Diagnostic Shutdown - Auto Reset	The compressor has been shutdown on a diagnostic that may clear automatically.
Restart Inhibit	The compressor is currently unable to start due to its restart inhibit timer. A given compressor is not allowed to start until 5 minutes has expired since its last start.
Auto	The given compressor is not currently running but can be expected to start at any moment given that the proper conditions occur.
No Sub Modes	
Starting	The given compressor is going through the necessary steps to allow it to start. (This mode is short and transitory)
No Sub Modes	
Running	The given compressor is currently running. Further information is provided by the sub-mode:
Establishing Min. Capacity - High Oil Temp	The compressor is running and is being forced loaded to its step load point, without regard to the leaving water temperature control, to prevent tripping on high oil temperature.
Running - Limited	The given compressor is currently running, but its capacity is being actively limited by the controls. Further information is provided by the sub-mode:
Capacity Limited by High Current	The compressor is running and its capacity is being limited by high currents. The current limit setting is 120% RLA (to avoid overcurrent trips) or lower as set by the compressor's "share" of the active current limit (demand limit) setting for the entire chiller.
Capacity Limited by Phase Unbalance	The compressor is running and its capacity is being limited by excessive phase current unbalance.
Shutting Down	The given compressor is still running but shutdown is imminent. The compressor is going through either a run-unload mode or is the active compressor in the operational pumpdown cycle for its circuit. Shutdown is either normal (no sub-mode displayed) or due the following sub-modes:
Diagnostic Shutdown - Manual Reset	The compressor is in the process of shutdown due to a latching diagnostic.
Diagnostic Shutdown - Auto Reset	The compressor is in the process of shutdown due to a diagnostic that may clear automatically.
Service Tool Lockout	The compressor is in the process of shutdown due to a command from the TechView Service Tool to be "locked out" and inoperative. This setting is nonvolatile and operation can only be restored by using TechView to "unlock" it.

Chiller Screen

The chiller screen is a summary of the chiller activity.

Modes	Chiller	Compressor
Evap Leaving Water Temperature:	44.0 F	
Evap Entering Water Temperature:	54.0 F	
Active Chilled Water Setpoint:	44.0 F	▶▶
Active Current Limit Setpoint:	100 %	▶▶
Outdoor Air Temperature:	72.0 F	
Software Version:	18.0	
<input type="radio"/>	Auto	Stop <input type="radio"/>

Table 57. Chiller screen

Description	Resolution	Units
Evap Leaving Water Temperature	X.X	F / C
Evap Entering Water Temperature	X.X	F / C
Active Chilled Water Setpoint	X.X	F / C
Active Current Limit Setpoint	X	% RLA
Out Door Temperature	X.X	F / C
Software Type	RTA	Text
Software Version	X.XX	Text

Compressor Screen

The compressor screen displays information for the one, two, three, or four compressors in the format shown. The top line of radio buttons allows you to select the compressor of interest. The next three lines show the compressor operating mode. The compressor radio buttons and the compressor operating mode lines don't change as you scroll down in the menu.

The top screen has no upward scroll keys. The single arrow down scrolls the screen one line at a time. As soon as the display is one line away from the top, the upward pointing arrow appears.

The last screen has a single arrow to scroll upward one line at a time. When in the last position, the single down arrow disappears.

Each compressor has its own screen depending on which radio key is pressed. When toggling between compressor screens, say to compare starts and run time, the same lines can be seen without additional key strokes. For example, toggling from the bottom of the compressor 1A menu accesses the top of the compressor 2A menu.

Modes	Chiller	Compressor
▼	1A	1B 2A 2B
Amps L1 L2 L3:	55.0	56.2 54.3
% RLA:	86.0	88.4 84.3
Unit Volts:	460	
Oil Temperature:	95.0	F
Intermediate Oil Pressure:	102.9	psig
Suction Pressure:	32.6	psig
<input type="radio"/>	Auto	Stop <input type="radio"/>

Table 58. Compressor screen

Description	Resolution	Units
Amps L1 L2 L3	XXX	Amps
% RLA L1 L2 L3	X.X	% RLA
Unit Volts	XXX	Volts
Oil Temperature	X.X	F / C
Intermediate Oil Pressure	X.X	Pressure
Suction Pressure	X.X	Pressure
Starts/ Run Hours	X, XX:XX	hr:min

Refrigerant Screen

The refrigerant screen displays those aspects of the chiller related to the refrigerant circuits.

Chiller	Compressor	Rfgt.
		Ckt 1 Ckt 2
Cond Rfgt Pressure:	185.0	185.0 psig
Sat Cond Rfgt Temp:	125.0	125.0 F
Evap Rfgt Pressure:	30.0	30.0 psig
Sat Evap Rfgt Temp:	34.0	34.0 F
Evap Approach Temp:	4.0	4.0 F
Rfgt Liquid Level:	0.1	-0.1 in
<input type="radio"/>	Auto	Stop <input type="radio"/>

Table 59. Refrigerant screen

Description	Resolution	Units
Cond Rfgt Pressure Ckt1/Ckt2	X.X	Pressure
Sat Cond Rfgt Temp Ckt1/Ckt2	X.X	F / C
Evap Rfgt Pressure Ckt1/Ckt2	X.X	Pressure
Sat Evap Rfgt Temp Ckt1/Ckt2	X.X	F / C
Evap Approach Temp Ckt1/Ckt2	X.X	F / C
Rfgt Liquid Level Ckt1/Ckt2	X.X	Height

Setpoint Screen

The setpoint screen is a two-part screen. Screen 1 lists all setpoints available to change along with their current value. The operator selects a setpoint to change by touching either the verbal description or setpoint value. Doing this causes the screen to switch to Screen 2.

In Screen 1 the language setpoint will always be the last setpoint in the list. This will facilitate language changes by placing that control in a standard position across all CH.530 product lines.

Screen 2 displays the current value of the chosen setpoint in the upper ½ of the display. It is displayed in a changeable format consistent with its type. Binary setpoints are considered to be simple two state enumeration and will use radio buttons. Analog setpoints are displayed as spin buttons. The lower half of the screen is reserved for help screens.

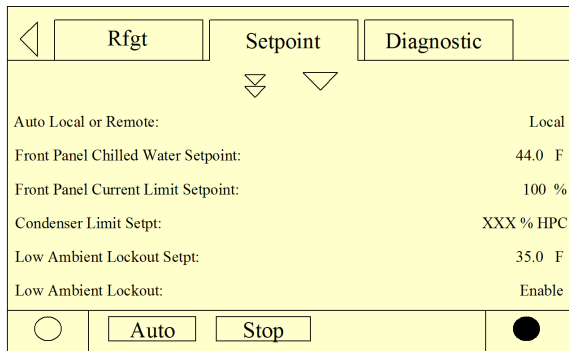

Table 60. Setpoint screen

Description	Resolution or Text	Units
Auto Local or Remote	Remote/Local	Text
Front Panel Chilled Water Setpoint	X.X	F / C

Table 60. Setpoint screen (continued)

Description	Resolution or Text	Units
Front Panel Current Limit Setpoint	XXX	% RLA
Differential to Start	X.X	Temperature
Differential to Stop	X.X	Temperature
Condenser Limit Setpoint	Enable/Disable	Text
Low Ambient Lockout Setpoint	X.X	Temperature
Low Ambient Lockout	Enable/Disable	Text
Ice Build	Enable/Disable	Text
Front Panel Ice Termination Setpoint	X.X	Temperature
Comp 1A Pumpdown	Pumpdown/Abort	Text
Comp 1B Pumpdown	Pumpdown/Abort	Text
Comp 2A Pumpdown	Pumpdown/Abort	Text
Comp 2B Pumpdown	Pumpdown/Abort	Text
EXV Ckt 1 Open	Auto/Open	Text
EXV Ckt 2 Open	Auto/Open	Text
Front Panel Ckt 1 Lockout	Locked Out/Not Locked Out	Text
Front Panel Ckt 2 Lockout	Locked Out/Not Locked Out	Text
Ext Chilled Water Setpoint	X.X	F / C
Ext Current Limit Setpoint	XXX	% RLA
Date Format	mmm dd yyyy, dd mm yyyy	Text
Date		Text
Time Format	12 hr, 24 hr	Text
Time of Day		Text
Keypad/Display Lockout	Enable/Disable	Text
Display Units	SI, English	Text
Pressure Units	Absolute, Gauge	Text
Language Selection	Downloaded from TechView	Text

Table 61 Setpoint options/conditions displayed

Option	Condition(s)	Explanation
Ice Building	Enable/Disable	If feature is installed, operation can be initiated or stopped
Cprsr Pumpdown ¹	Avail	Pumpdown is allowed: only with unit in Stop or when circuit is locked out
	Not Avail	Pumpdown is not allowed because unit is operating or pumpdown has been completed
	Pumpdown	State is displayed while pumpdown is in progress
EXV Ckt Open (For Authorized Service Use Only ²)	Avail	Indicates EXV is closed but can be opened manually since unit is in Stop or circuit is locked out
	Not Avail	EXV is closed but cannot be opened manually since unit is operating
	Open	State is displayed when EXV is open. Unit will not start with EXV manually set open, but will initiate valve closure first.
Ckt Lockout	Locked Out	Circuit is locked out at Front Panel; other circuit may be available to run
	Not Locked Out	Circuit is not locked out and is available to run

Notes:

¹ Pumpdown procedure are discussed in Maintenance section 10.

² Used for liquid level control or to recover from pumpdown

Table 61 Setpoint options/conditions displayed (continued)

Option	Condition(s)	Explanation
Ext. Chilled Water Setpt	Enable/Disable	Allows unit to control setpoint; otherwise another loop controller in line will control, as optionally wired.
Ext. Current Limit Setpt	Enable/Disable	Allows unit to control setpoint; otherwise another loop controller in line will control, as optionally wired.

Notes:
¹ Pumpdown procedure are discussed in Maintenance section 10.

² Used for liquid level control or to recover from pumpdown

Diagnostic Screen

The diagnostic screen (shown following) is accessible by either pressing the blinking ALARMS key or by pressing the **Diagnostic** tab on the screen tab selection.

A hex code and a verbal description appears on the display as shown typically above. This is the last active diagnostic. Pressing the “Reset All Active Diagnostics” will reset all active diagnostics regardless of type, machine or refrigerant circuit. Compressor diagnostics, which hold off only one compressor, are treated as circuit diagnostics, consistent with the circuit to which they belong. One circuit not operating will not shut the chiller down. Viewing the “Compressor” screen will indicate whether a circuit is not operating and for what reason.

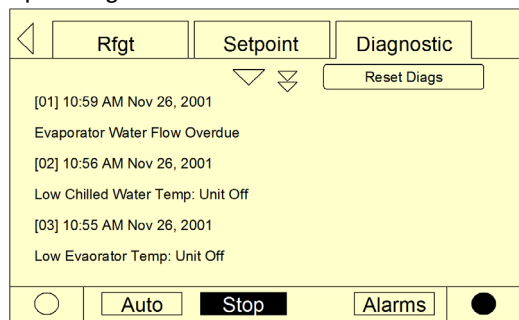

A complete listing of diagnostics and codes is included in the Diagnostic Section.

Power-Up

On Power-Up, DynaView will cycle through three screens:

- First Screen, Version # of the Boot, full version # displayed.
 - This screen will display for 5 seconds before moving to second screen. Contrast is adjustable from this screen.
- Second Screen, Application or No Application.
 - This screen will display for 5 seconds “A Valid Application Is Present” or “A Valid Application Is Not Present”
- Third Screen, First screen of the Application, the Chiller Tab

Display Formats

Units

Temperature settings are in °F or °C, depending on Display Units settings. Settings can be entered in tenths or whole degrees depending on a menu setting at the TechView.

Dashes (“-----”) appearing in a temperature or pressure report, indicates that the value is invalid or not applicable.

Languages

English plus two alternate languages may be installed with DynaView and will reside in the main processor. English will always be available. Alternate languages must be installed using TechView, Software Download View.

TechView



TechView™ is the PC (laptop) based tool used for servicing Tracer CH530. Technicians that make any chiller control modification or service any diagnostic with Tracer CH530 must use a laptop running the software application “TechView.” TechView is a Trane application developed to minimize chiller downtime and aid the technicians understanding of chiller operation and service requirements.

Note: Important: Performing any Tracer CH530 service functions should be done only by a properly trained service technician. Please contact your local Trane service agency for assistance with any service requirements.



Controls Interface

TechView software is available via Trane.com.

(<http://www.trane.com/COMMERCIAL/DesignAnalysis/TechView.aspx?i=1435>)

This download site provides a user the TechView installation software and CH530 main processor software that must be loaded onto your PC in order to service a CH530 main processor. The TechView service tool is used to load software into the Tracer CH530 main processor

Minimum PC requirements to install and operate TechView

- Microsoft Windows XP Professional, Windows Vista Business or Windows 7 Enterprise
- Internet Explorer 6.0 or higher
- USB 2.0 or higher
- Pentium II, III or higher processor
- 128Mb RAM minimum for TechView, 1G recommended for total Windows system
- 1024 x 768 resolution of display
- CD-ROM (optional for copying TechView install to CD)
- 56K modem (optional for internet connection)
- 9-pin RS-232 serial connection (optional for connection to DynaView)

Note: TechView was designed for the preceding listed laptop configuration. Any variation will have unknown results. Therefore, support for TechView is limited to only those operating systems that meet the specific configuration listed here. Only computers with a Pentium II class processor or better are supported; Intel Celeron, AMD, or Cyrix processors have not been tested.

TechView is also used to perform any CH530 service or maintenance function. Servicing a CH530 main processor includes:

- Updating main processor software
- Monitoring chiller operation
- Viewing and resetting chiller diagnostics
- Low Level Intelligent Device (LLID) replacement and binding
- Main processor replacement and configuration modifications
- Setpoint modifications
- Service overrides

TechView Software Download, Installation

This information can also be found at <http://www.trane.com/COMMERCIAL/DesignAnalysis/TechView.aspx?i=1435>.

1. Create a folder called "CH530" on your (C:\CH530) on your hard drive. This \CH530 folder is the standard recommended location for the installation file. Storing

the installation file in this location helps you remember where it is stored and makes it easier for technical support personnel to assist you.

2. Click the link for the latest version on the TechView Software Download page. Enter your name, e-mail address and other required information. Click **Submit**.
3. A download link will be sent to the e-mail address provided. Before you click the link please note:
 - Sent link may only be used one time.
 - Internet options must be set correctly to allow download. To verify correct setting:
 - Open Internet Explorer Browser
 - Click **Tools**
 - Select **Internet Options**
 - Select **Security** tab
 - Click on **Internet** zone
 - Click **Custom Level** button
 - Scroll to **Downloads** section
 - Verify/Enable "Automatic prompting for file downloads"
 - Click **OK**
 - Click YES on warning window
 - Click Apply, then OK

Note: If this setting is incorrect, you may or may not receive an error message during download attempt.

4. Click the download link in the e-mail message.
 - If the download window does not open immediately, please look for a yellow highlighted message bar/line near the top of your browser. It may contain a message such as "To help protect your security, Internet Explorer blocked this site from downloading files to your computer. Click here for options..." Click on message line to see options.
 - When dialog box appears, click **Save** and navigate to the CH530 folder created in [Step 1](#). Click OK.
 - If you do not complete the download successfully, you will have to request another download link ([Step 2](#)).
5. Navigate to the CH530 folder created in [Step 1](#). Double-click the installation (.exe) file. The License Agreement dialog box appears.
6. Click **I Agree** after reviewing License Agreement. The **Choose Components** dialog box appears. All components are selected by default. (These are the actual MP versions for all units.) Deselect any components you do not want.

Note: Deselecting components reduces the size of the installed application.

7. Click **Install**. A progress meter dialog box appears. An information file appears when installation is complete.

Note: *Techview requires a current version of JAVA. If you do not have the current release, TechView installation will be interrupted, and you will be provided with information for required JAVA software download. Once you have completed the JAVA installation, return to [Step 5](#) to restart installation.*

Unit View

Unit view is a summary for the system organized by chiller subsystem. This provides an overall view of chiller operating parameters and gives you an “at-a-glance” assessment of chiller operation.

The Control Panel tab displays important operating information for the unit and allows you to change several key operating parameters. The panel is divided into four or more sub-panels (depending on the number of circuits in the unit).

The Operating Mode tab displays the unit, circuit and compressor top level operating modes.

The Hours and Starts tab displays the number a hours (total) a compressor has run and the number of times the compressor has started. This window plays a key role in evaluating maintenance requirements.

Upon successful Local Connect Tech View will display UNIT VIEW, as shown in [Figure 38, p. 89](#).

Compressor Service View

Compressor View provides convenient access to service functions for pumping down circuits and test starting compressors. Various operational lockouts allow operation of rest of chiller while others are awaiting repair. See [Figure 39, p. 90](#).

Status View

Status View displays, in real time, all non-setpoint data organized by subsystem tabs. As data changes on the

Table 62. Setpoints view items

Tab	Text	Min Value	Max Value	Default Value	Unit Type
Chiller	Front Panel Display Units	English, SI		English	Display Units
Chiller	Front Panel Chilled Water Setpoint	10 (-12.22)	65 (18.33)	44 (6.67)	Temp Deg F(C)
Chiller	Front Panel Current Limit Setpoint	60	120	120	Percent
Chiller	Differential to Stop	0.5 (0.2777)	2.5 (1.388)	2.0 (1.111)	Differential Temp Deg F(C)
Chiller	Differential to Start	1.0 (0.555)	30 (16.666)	2 (1.111)	Differential Temp Deg F(C)
Chiller	Leaving Water Temp Cutout	0.0 (-17.78)	36.0 (2.22)	36.0 (2.22)	Temp Deg F(C)
Chiller	Low Refrigerant Temp Cutout	-5.0 (-20.56)	36.0 (2.22)	28.0 (-2.22)	Temp Deg F(C)
Chiller	Front Panel Condenser Limit Setpoint	80	120	90	Percent
Chiller	Low Ambient Lockout Setpoint	-10 (-23.333)	70 (21.111)	25 (-3.89)	Temp Deg F(C)
Chiller	Low Ambient Lockout	Enable, Disable		Enable	Enabled / Disabled

chiller it is automatically updated in Status View. See [Figure 40, p. 90](#).

Setpoint View

Setpoint view displays the active setpoints and allows you to make changes. See [Figure 41, p. 90](#).

Setpoint List

The center displays the scrollable list of setpoint panels.

Setpoint Enumeration Panel

A setpoint numeric panel contains a label with the setpoint description and a pull-down list showing the active value and the other selections. The Default button returns the setpoint to the product's factory setting. The text field is updated when the change is complete.

Setpoint Numeric Panel

A setpoint numeric panel contains a label with the setpoint description, a Default button, a text field with a unit label, and a slider.

The Default button changes the setpoint to the product's factory setting. The text field and slider are updated when the change is complete.

You can change a setpoint with the text field or with the slider. When you click on the entry field, the change setpoint dialog displays to coordinate the setpoint change.

You can change the display units for a setpoint by clicking on the unit label next to the entry field.

Change Setpoint

The change setpoint window allows you to enter a new value for the setpoint into a text field. If the entered value is outside the given range, the background turns red.

Table 62. Setpoints view items (continued)

Tab	Text	Min Value	Max Value	Default Value	Unit Type
Chiller	Front Panel Ice Termination Setpoint	20 (-6.67)	31 (-0.56)	31 (-0.56)	Temp Deg F(C)
Chiller	External Ice Building Input	Enable, Disable		Disable	Enabled / Disabled
Chiller	Under/Over Voltage Protection	Enable, Disable		Disable	Enabled / Disabled
Chiller	Local Atmospheric Pressure	9.93 (68.5)	16.0 (110.3)	14.7 (101.3)	Absolute Pressure psia(Kpa)
Chiller	Design Delta Temperature	4 (2.22)	30 (16.666)	10 (5.6)	Differential Temp Deg F(C)
Chiller	Reset Type	None, Return, Outdoor, Constant Return		None	RstTyp
Chiller	Return Reset Ratio	10	120	50	Percent
Chiller	Return Start Reset	4.0 (2.22)	30.0 (16.666)	10.0 (5.56)	Differential Temp Deg F(C)
Chiller	Return Maximum Reset	0	20 (11.11)	5.0 (2.78)	Differential Temp Deg F(C)
Chiller	Outdoor Reset Ratio	-80	80	10	Percent
Chiller	Outdoor Start Reset	50 (10)	130 (54.44)	90 (32.22)	Temp Deg F(C)
Chiller	Outdoor Maximum Reset	0	20 (11.11)	5 (2.78)	Differential Temp Deg F(C)
Chiller	External Chilled Water Setpoint	Enable, Disable		Disable	Enabled / Disabled
Chiller	External Current Limit Setpoint	Enable, Disable		Disable	Enabled / Disabled
Chiller	Evaporator Water Pump Off Delay	0	30	1	Minutes
Chiller	Chilled Water Setpoint Filter Settling Time 30		1800	200	Seconds
Chiller	Compressor Staging Deadband	0.4 (0.222)	4.0 (2.222)	0.05 (0.2778)	Differential Temp Deg F(C)

Diagnostics View

See [Figure 42, p. 90](#). This window lists the active and inactive (history) diagnostics. There can be up to 60 diagnostics, both active and historic. For example, if there were 5 active diagnostics, the possible number of historic diagnostics would be 55. You can also reset active diagnostics here, (i.e., transfer active diagnostics to history and allow the chiller to regenerate any active diagnostics).

Resetting the active diagnostics may cause the chiller to resume operation.

The Active and History diagnostics have separate tabs. A button to reset the active diagnostics displays when either tab is selected.

Configuration View

See [Figure 43, p. 91](#). This view displays the active configuration and allows you to make changes.

Configuration View allows you to define the chiller's components, ratings, and configuration settings. These are all values that determine the required installed devices, and how the chiller application is run in the main processor. For example, a user may set an option to be installed with Configuration View, which will require devices to be bound using Binding View. And when the main processor runs the chiller application, the

appropriate steps are taken to monitor required inputs and control necessary outputs.

Any changes made in the Configuration View, on any of the tabs, will modify the chiller configuration when you click on the Load Configuration button (located at the base of the window). The Load Configuration button uploads the new configuration settings into the main processor.

Any changes made to the configuration will change the unit model number and the confirmation code (CRC). If changes are made to the unit configuration the new model number and CRC should be recorded.

Selecting the Undo All button will undo any configuration setting changes made during the present TechView connection and since the last time the Load Configuration button was selected.

Table 63. Configuration View Items

Tab	Item	Default	Description
Feature	Basic Product Line		RTAC - Air Cooled Series R Chiller
			120 Nominal Tons 130 Nominal Tons 140 Nominal Tons 155 Nominal Tons 170 Nominal Tons 185 Nominal Tons 200 Nominal Tons 225 Nominal Tons 250 Nominal Tons 275 Nominal Tons 300 Nominal Tons 350 Nominal Tons 375 Nominal Tons 400 Nominal Tons 450 Nominal Tons 500 Nominal Tons
	Unit Nominal Capacity		
	Unit Voltage		A - 200V/60Hz/3Ph power C - 230V/60Hz/3Ph power J - 380V/60Hz/3Ph power D - 400V/50Hz/3Ph power 4 - 460V/60Hz/3Ph power 5 - 575V/60Hz/3Ph power
	Manufacturing Location		U - Water Chiller Business Unit - Pueblo E - Epinal Business Unit -Charmes
	Design Sequence		XX - Factory/ABU Assigned
	Unit Type		N - Standard Efficiency/Performance H - High Efficiency/Performance A - Extra Efficiency/Performance
	Agency Listing		N - No agency listing U - C/UL listing
	Pressure Vessel Code		A - ASME pressure vessel code C - Canadian code D - Australian code L - Chinese code R - Vietnamese code S - Special
	Evaporator Temperature Range & Application Type		F - Standard Temperature with Freeze Protection R - Rem Evap, Std Temp, No Freeze Protection G - Low Temp, with Freeze Protection
	Evaporator Configuration		N - Standard 2 pass arrangement, insulated P -3 pass arrangement, insulated
	Condenser Temperature Range		N - Standard ambient 25-115°F H - High ambient 25-125°F L - Low ambient 0-115°F W - Wide ambient 0-125°F
	Condenser Fin Material		1 - Standard aluminum slit fins 2 - Copper fins, non-slit fins 4 - Complete Coat aluminum fins
Feature	Condenser Fan/Motor Configuration		T - Standard fans, TEAO motors W - Low Noise fans
			X - Across-the-line Y - Wye-delta closed transition
	Compressor Motor Starter Type		1 -Single point 2 -Dual point (1/ckt)
			T - Terminals only D - Non-fused disconnect switch(es) C - Circuit Breaker(s), HACR-rated
	Incoming Power Line Connection		
	Power Line Connection Type		
	Unit Operator Interface		D -Dyna-View



Controls Interface

Table 63. Configuration View Items (continued)

Tab	Item	Default	Description
	Remote Interface		N - No remote interface C - Tracer Comm 3 interface B - BACnet communication interface L - Lon Talk Communication interface (LCI)
	Control Input Accessories/Options		N -No remote input R -Remote leaving water temp setpoint C -Remote current limit setpoint B -Remote leaving temp setpoint and remote current limit setpoint
	Control Output Accessories/Options		N -No output options A -Alarm relay C -Icemaking D -Icemaking and alarm relay
	Short Circuit Rating		0 - No short circuit withstand rating 5 -Default short circuit rating 6 - High amp short circuit rating
	Control Panel Accessories		N - No convenience outlet A - 15A 115V convenience outlet (60HZ)
	Refrigerant Service Valves		0 - No suction services valves 1 - Suction service valves
	Compressor Sound Attenuator Option		0 - No sound attenuator 1 - Factory installed sound attenuator
	Appearance Options		N - No appearance options A - Architectural louvered panels C - Half Louvers P - Painted unit L - Painted unit with full louvered panels H - Painted unit with half louvered panels K - Painted unit with access guards W - Painted w/access guards and half louvers
Features	Installation Accessories		N - No installation accessories R - Neoprene Isolators F - Flanged water connection kit G - Neoprene isolators and flange wtr conn kit
	Factory Test		0 - No factory run test
	Control, Label, and Literature Language		E - English G - Chinese
	Special Order		X - Standard catalog configuration S - Unit has special order feature
Custom	Comm 3 ICS address	55	1-64 REM = C
	Status Relay #1 J2-10,11,12	Alarm - Latching	None, Alarm - Latching (Active diagnostic persistence latching), Alarm - Auto reset (Active diagnostic persistence non-latching), Alarm (Active diagnostic persistence latching or non-latching), Alarm Ckt1 (Active diagnostic persistence latching or non-latching), Alarm Ckt2 (Active diagnostic persistence latching or non-latching), Chiller Limit Mode (With 20 minute filter), Circuit 1 Running, Circuit 2 Running, Max Capacity COOP = A, D or X
	Status Relay #2 J2-7,8,9	Chiller Running	
	Status Relay #3 J2-4,5,6	Maximum Capacity	
	Status Relay #4 J2-1,2,3	Chiller Limit Mode	
	Phase Unbalance Trip	30	10-50%
	Phase Unbalance Grace Period	90	30-255 Sec
	Maximum Acceleration Time	3	1-255 Sec
	Starter Feature	All Enabled	Contactors Integrity Test, Phase Reversal Detect, Phase Unbalance Detect
	External Chilled Water Setpoint Detection	2-10 VD	2-10 VDC, 4-20 mA CIOP = C or B
	External Current Limit Water Setpoint Detection	2-10 VDC	2-10 VDC, 4-20 mA CIOP = C or B
	Custom Unit Voltage	400	380,400,415 VOLT = D
Name-plate	<ul style="list-style-type: none"> The Model Number field contains the model number stored in the DynaView. The Confirm Code field contains the confirm code stored in the DynaView. The confirm code is a four-digit hex value that is a mathematical calculation of the model number. This number has one to one correlation to a specific model number and is used to verify that the model number was entered properly. The Serial Number field contains the serial number stored in the DynaView. This model number and confirmation code must be know when the main processor requires replacement. 		

Software View

See [Figure 44, p. 91](#). Software view allows you to verify the version of chiller software currently running and download a new version of chiller software to DynaView.

You can also add up to two available languages to load into the DynaView. Loading an alternate language file allows the DynaView to display its text in the selected alternate language, English will always be available.

Binding View

See [Figure 45, p. 91](#). Binding View allows you to assess the status of the network and all the devices connected as a whole, or the status of individual devices by using status icons and function buttons.

Binding View is essentially a table depicting what devices and options are actually discovered on the network bus (and their communication status) versus what is required to support the configuration defined by the feature codes and categories. Binding View allows you to add, remove, modify, verify, and reassign devices and options in order to match the configuration requirements.

Whenever a device is installed, it must be correctly configured to communicate and function as intended. This process is called binding. Some features of Binding View are intended to serve a second purpose; that is diagnosing problems with communication among the devices.

Replacing or Adding Devices

If a device is communicating but incorrectly configured, it might not be necessary to replace it. If the problem with the device is related to communication, attempt to rebind it, and if the device becomes correctly configured, it will then communicate properly.

If a device that needs to be replaced is still communicating, it should be unbound. Otherwise, it will be necessary to rebuild the CH530 network image for Binding View to discover that it has been removed. An unbound device stops communicating and allows a new device to be bound in its place.

It is good practice to turn the power off while detaching and attaching devices to the CH530 network. Be sure to keep power on the service tool computer. After power is restored to the CH530 network, the reconnect function in Binding View restores communication with the network. If the service tool computer is turned off, you must restart TechView and Binding View.

If a device is not communicating, the binding function displays a window to request manual selection of the device to be bound. Previously-selected devices are deselected when the function starts. When manual selection is confirmed, exactly one device must be selected; if it is the correct type, it is bound. If the desired device cannot be selected or if multiple devices are accidentally selected, you can close the manual selection window by clicking on No and repeat the bind function.

Figure 38. Unit view

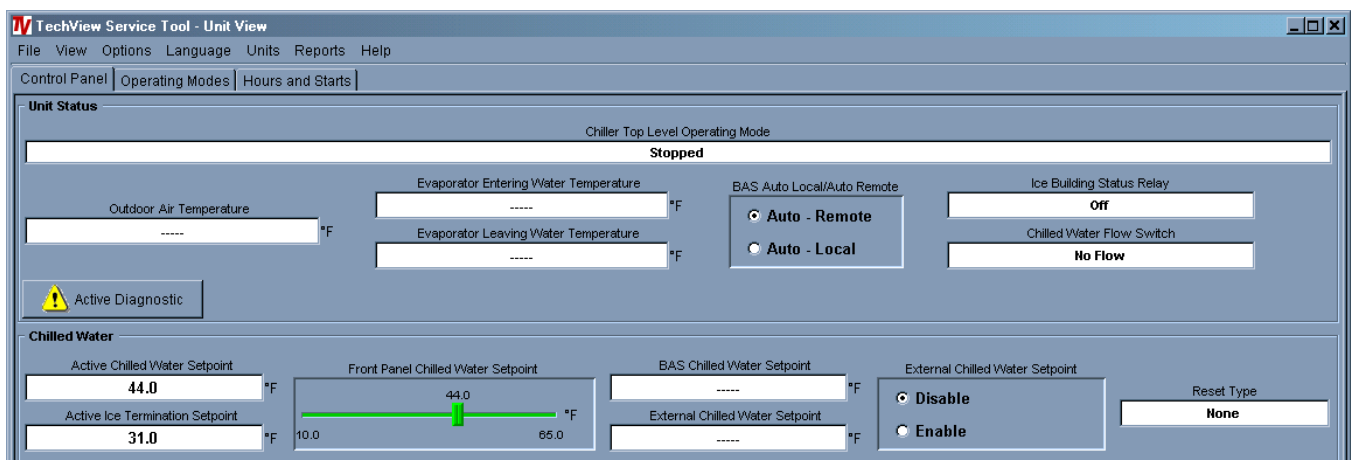

Figure 39. Compressor service view

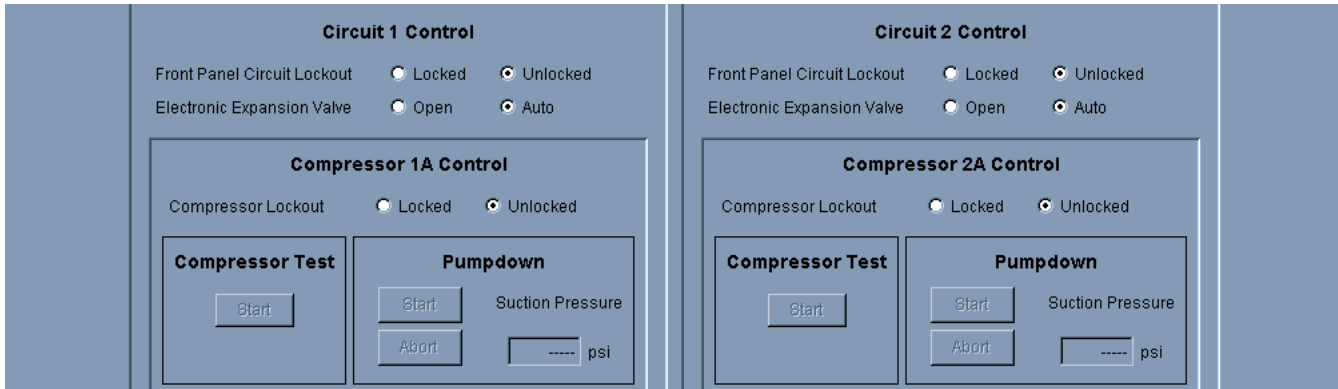

Figure 40. Status view

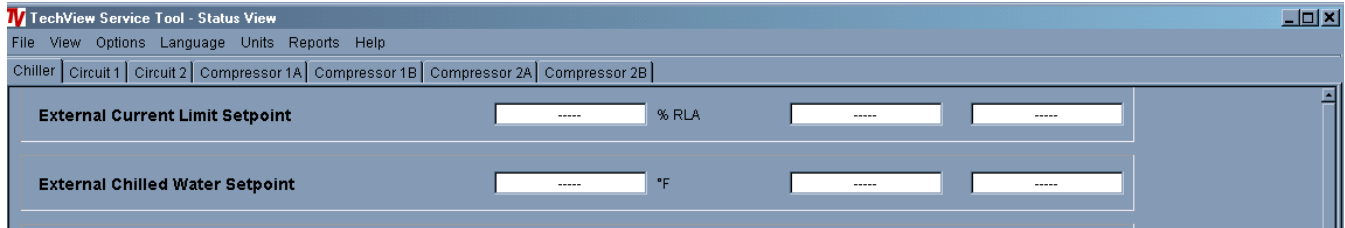
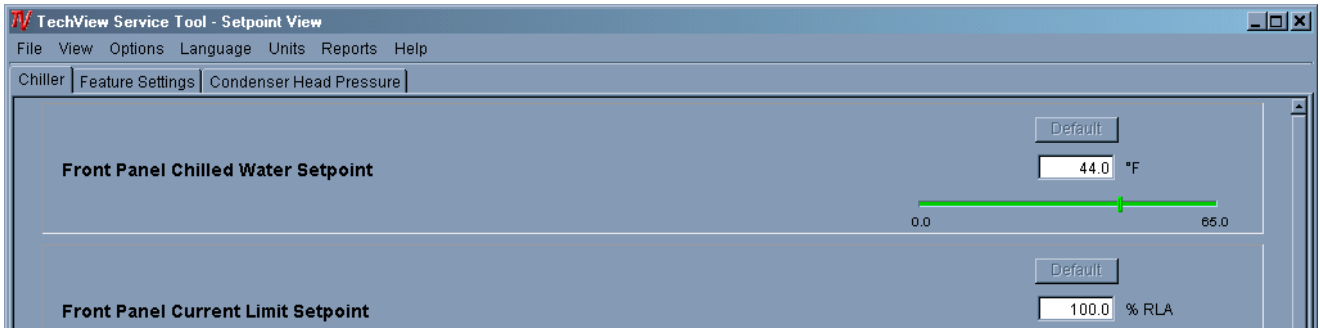

Figure 41. Setpoint view^(a)



(a) Screenshot is representation only. Values shown may not correspond to actual min/max levels in Table 62, p. 85.

Figure 42. Diagnostic view

Date/Time	Description	Target	Severity	Persistence
Feb 14, 1922 11:47 PM	Evaporator Water Flow Overdue	Chiller	Normal Shutdown	Nonlatching
Feb 14, 1922 11:27 PM	Low Chilled Water Temp: Unit Off	Chiller	Warning	Nonlatching
Feb 14, 1922 11:27 PM	Excessive IPC Comm Loss	Chiller	Immediate Shutdown	Latching

Figure 43. Configuration view

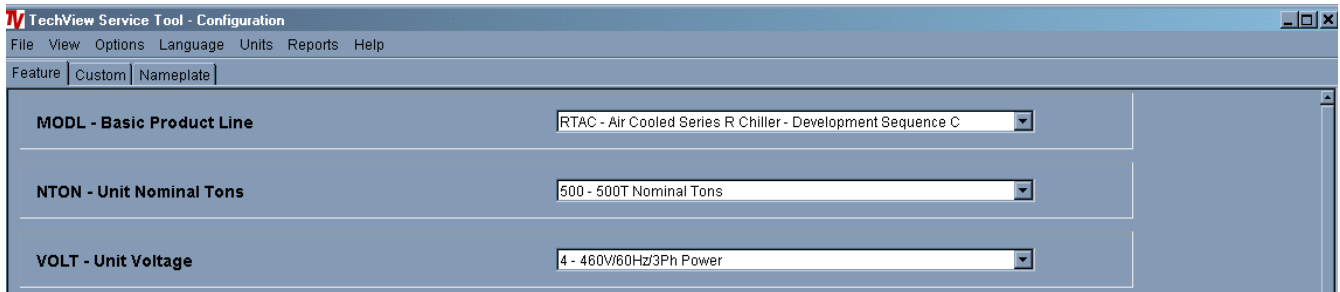

Figure 44. Software view

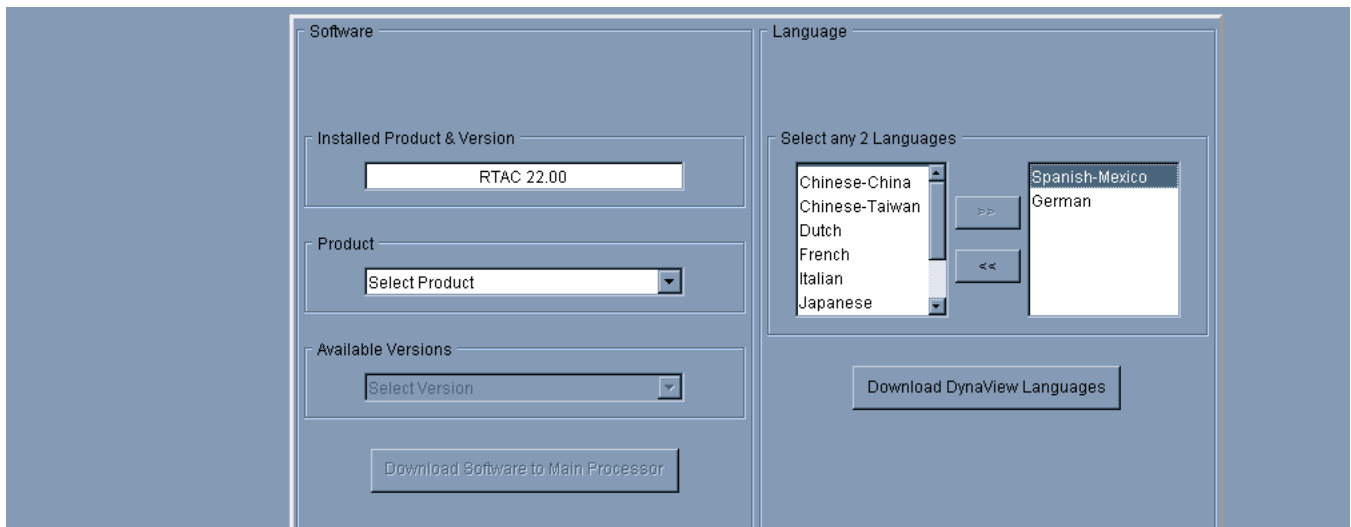
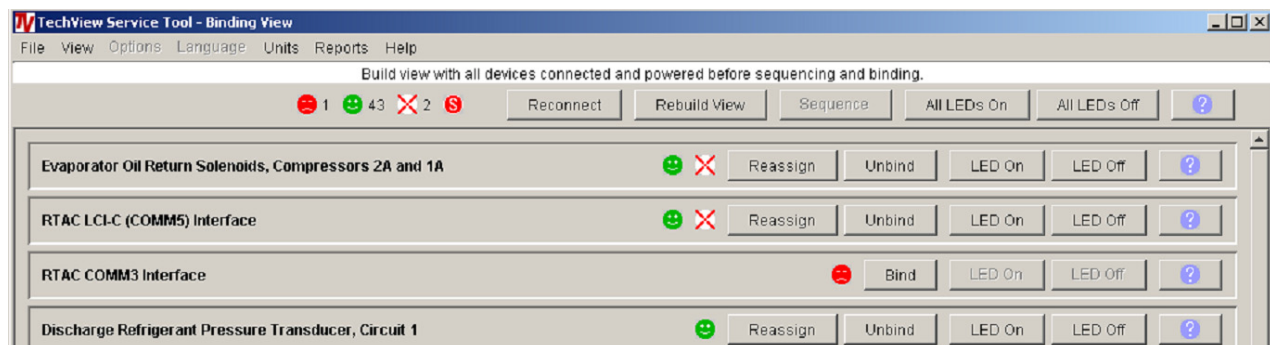

Figure 45. Binding view





Pre-Start Checkout

Upon completion of installation, complete the RTAC Series R[®] Air-Cooled Chiller Installation Completion Check Sheet and Request for Trane Service checklist in chapter “[Log and Check Sheet](#),” p. 124.

Important: *Start-up must be performed by Trane or an agent of Trane specifically authorized to perform start-up and warranty of Trane products. Contractor shall provide Trane (or an agent of Trane specifically authorized to perform start-up) with notice of the scheduled start-up at least two weeks prior to the scheduled start-up.*



Start-Up and Shutdown

Important: Initial unit commissioning start-up must be performed by Trane or an agent of Trane specifically authorized to perform start-up and warranty of Trane products. Contractor shall provide Trane (or an agent of Trane specifically authorized to perform start-up) with notice of the scheduled start-up at least two weeks prior to the scheduled start-up.

The time line for sequence of operation is shown in Figure 46, p. 96 and Figure 47, p. 98 and depicts the nominal delays and sequences that a chiller would experience during a typical operational cycle. The time line begins with a power up of the main power to the chiller. The sequence assumes a 2 circuit, 2 compressor air-cooled RTAC chiller with no diagnostics or malfunctioning components. External events such as the operator placing the chiller in Auto or Stop, chilled water flow through the evaporator, and application of load to the chilled water loop causing loop water temperature increases are depicted and the chillers responses to those events are shown, with appropriate delays noted. The effects of diagnostics, and other external interlocks other than evaporator water flow proving, are not considered.

Note: Unless the CH530 TechView and building automation system are controlling the chilled water pump, the manual unit start sequence is as follows. Operator actions are noted.

NOTICE:

Compressor Damage!

Ensure that the compressor and oil separator heaters have been operating for a minimum of 24 hours before starting. Failure to do so could result in equipment damage.

Unit Start-Up

If the pre-start checkout, has been completed, the unit is ready to start.

1. Press the STOP key on the CH530.
2. As necessary, adjust the setpoint values in the CH530 menus using TechView.
3. Close the fused-disconnect switch for the chilled water pump. Energize the pump(s) to start water circulation.
4. Check the service valves on the discharge line, suction line, oil line and liquid line for each circuit. These valves must be open (backseated) before starting the compressors.

NOTICE:

Compressor Damage!

Catastrophic damage to the compressor will occur if the oil line shut off valve or the isolation valves are left closed on unit start-up

5. Press the AUTO key. If the chiller control calls for cooling and all safety interlocks are closed, the unit will start. The compressor(s) will load and unload in response to the leaving chilled water temperature.
6. Verify that the chilled water pump runs for at least one minute after the chiller is commanded to stop (for normal chilled water systems).

Once the system has been operating for approximately 30 minutes and has become stabilized, complete the remaining start-up procedures, as follows:

1. Check the evaporator refrigerant pressure and the condenser refrigerant pressure under Refrigerant Report on the CH530 TechView. The pressures are referenced to sea level (14.6960 psia).
2. Check the EXV sight glasses after sufficient time has elapsed to stabilize the chiller. The refrigerant flow past the sight glasses should be clear. Bubbles in the refrigerant indicate either low refrigerant charge or excessive pressure drop in the liquid line or a stuck open expansion valve. A restriction in the line can sometimes be identified by a noticeable temperature differential between the two sides of the restriction. Frost will often form on the line at this point. Proper refrigerant charges are shown in the General Information Section.

Important: A clear sight glass alone does not mean that the system is properly charged. Also check system subcooling, liquid level control and unit operating pressures.

3. Measure the system subcooling.
4. A shortage of refrigerant is indicated if operating pressures are low and subcooling is also low. If the operating pressures, sight glass, superheat and subcooling readings indicate a refrigerant shortage, gas-charge refrigerant into each circuit, as required. With the unit running, add refrigerant vapor by connecting the charging line to the suction service valve and charging through the backseat port until operating conditions become normal.



Start-Up and Shutdown

NOTICE:

Equipment Damage!

If both suction and discharge pressures are low but sub-cooling is normal, a problem other than refrigerant shortage exists. Do not add refrigerant, as this could result in overcharging the circuit.

Use only refrigerants specified on the unit nameplate (HFC 134a) and Trane OIL00048. Failure to do so may cause compressor damage and improper unit operation.

Temporary Shutdown and Restart

To shut the unit down for a short time, use the following procedure:

1. Press the STOP key on the CH530. The compressors will continue to operate and, after an unloading period (which may be followed by pumpdown cycle in outdoor ambients below 50°F), will stop when the compressor contactors de-energize.
2. CH530 pump control will turn off the pump (after a minimum 1 min. delay) when the STOP key is pressed and automatically restart the pump when the unit starts normally.
3. The unit will start normally, provided the following conditions exist:
 - a. The CH530 receives a call for cooling and the differential-to-start is above the setpoint.
 - b. All system operating interlocks and safety circuits are satisfied.

Extended Shutdown Procedure

The following procedure is to be followed if the system is to be taken out of service for an extended period of time, e.g. seasonal shutdown:

1. Test the unit for refrigerant leaks and repair as necessary.
2. Open the electrical disconnect switches for the chilled water pump. Lock the switches in the "OPEN" position.

NOTICE:

Equipment Damage!

To prevent pump damage, lock the chilled water pump disconnects open.

3. Close all chilled water supply valves. Drain the water from the evaporator.
4. With the water drained from evaporator, the "customer provided" power for the 120-volt evaporator heaters (terminated at 1TB4...terminals 1 & 2) must be must disconnect.

These heaters consist of 1 well heater in each evaporator end (or water box), and the heat tape, which

is wrapped around the bundle itself. They are energized by a klixon temperature control mounted on the side of the evaporator, which energizes at or below 37°F. outside air temp. If there is no liquid in the evaporator and the temp drops below 37 degrees, both of the well heaters will burn up because they have no liquid to transfer their heat into.

5. Open the unit main electrical disconnect and unit-mounted disconnect (if installed) and lock on the "OPEN" position. If the optional control power transformer is not installed, open and lock the 115V disconnect.

NOTICE:

Equipment Damage!

If insufficient concentration or no glycol is used, the evaporator water pumps must be controlled by the CH530 to avoid severe damage to the evaporator due to freezing. A power loss of 15 minutes during freezing can damage the evaporator. It is the responsibility of the installing contractor and/or the customer to ensure that a pump will start when called upon by the chiller controls.

Please consult [Table 42, p. 54](#) for correct concentration of glycol.

The warranty will be void, in case of freezing due to the lack of use of either of these protections

NOTICE:

Equipment Damage!

Lock the disconnects in the "OPEN" position to prevent accidental start-up and damage to the system when it has been setup for extended shutdown.

6. At least every three months (quarterly), check the refrigerant pressure in the unit to verify that the refrigerant charge is intact.

Seasonal Unit Start-Up Procedure

1. Close all valves and re-install the drain plugs in the evaporator.
2. Service the auxiliary equipment according to the start-up/maintenance instructions provided by the respective equipment manufacturers.
3. Close the vents in the evaporator chilled water circuits.
4. Open all the valves in the evaporator chilled water circuits.
5. Open all refrigerant valves to verify they are in the open condition.
6. If the evaporator was previously drained, vent and fill the evaporator and chilled water circuit. When all air is removed from the system (including each pass), install the vent plugs in the evaporator water boxes.
7. Check the adjustment and operation of each safety and operating control.
8. Close all disconnect switches.
9. Refer to the sequence for daily unit startup for the remainder of the seasonal startup.

System Restart After Extended Shutdown

Follow the procedures below to restart the unit after extended shutdown:

1. Verify that the liquid line service valves, oil line, compressor discharge service valves and suction service valves are open (backseated).

NOTICE:

Compressor Damage!

Catastrophic damage to the compressor will occur if the oil line shut off valve or the isolation valves are left closed on unit start-up.

2. Check the oil separator oil level (see Maintenance Procedures section).
3. Fill the evaporator water circuit. Vent the system while it is being filled. Open the vent on the top of the evaporator and condenser while filling and close when filling is completed.

NOTICE:

Proper Water Treatment!

The use of untreated or improperly treated water in this equipment could result in scaling, erosion, corrosion, algae or slime. It is recommended that the services of a qualified water treatment specialist be engaged to determine what water treatment, if any, is required. Trane assumes no responsibility for equipment failures which result from untreated or improperly treated water, or saline or brackish water.

4. Close the fused-disconnect switches that provides power to the chilled water pump.
5. Start the evaporator water pump and, while water is circulating, inspect all piping for leakage. Make any necessary repairs before starting the unit.
6. While the water is circulating, adjust the water flows and check the water pressure drops through the evaporator. Refer to "Water System Flow Rates" and "Water System Pressure Drop".
7. Adjust the flow switch on the evaporator piping for proper operation.
8. Stop the water pump. The unit is now ready for start-up as described in "Start-Up Procedures".

Sequence of Operation

Figure 46. Sequence of operations

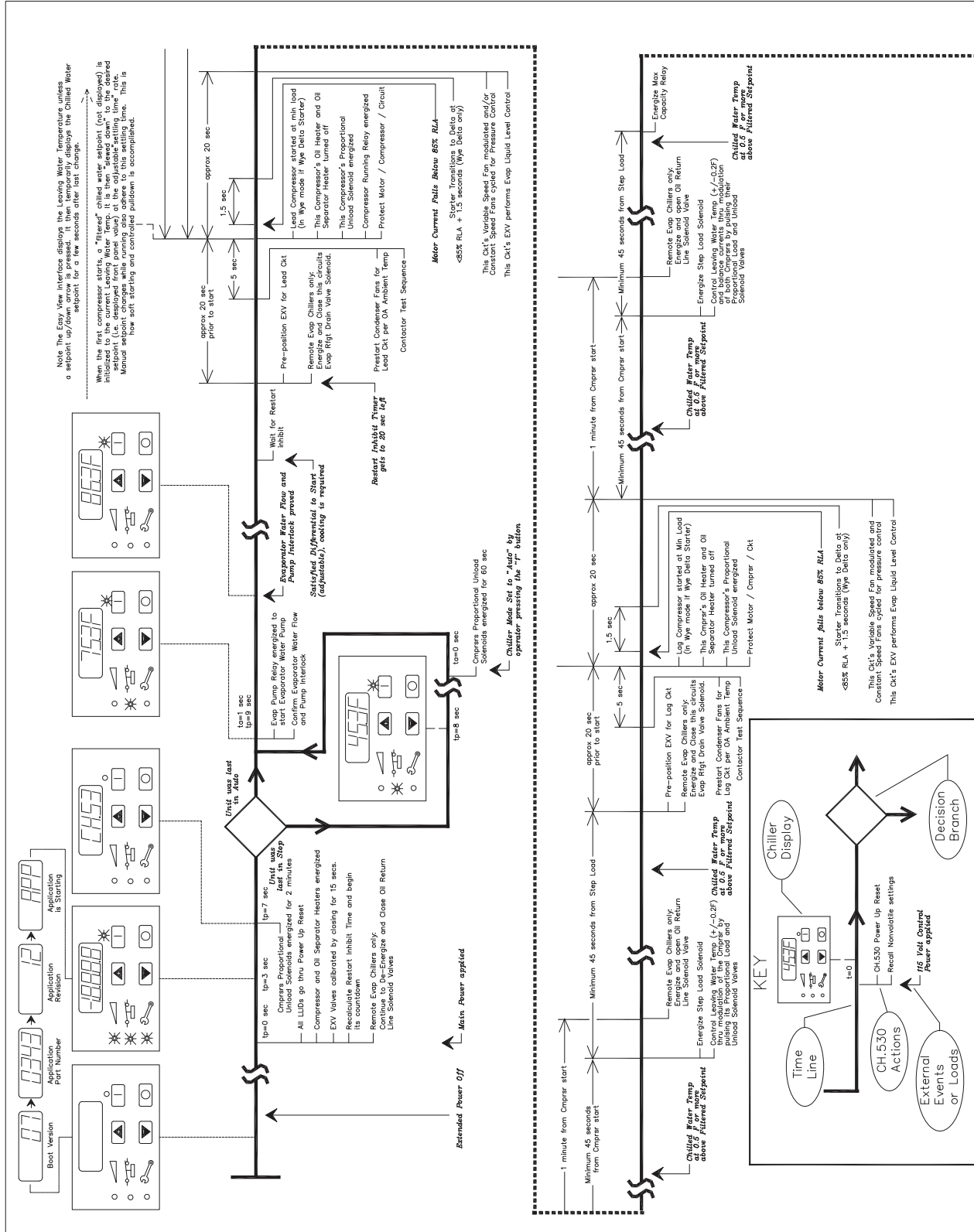

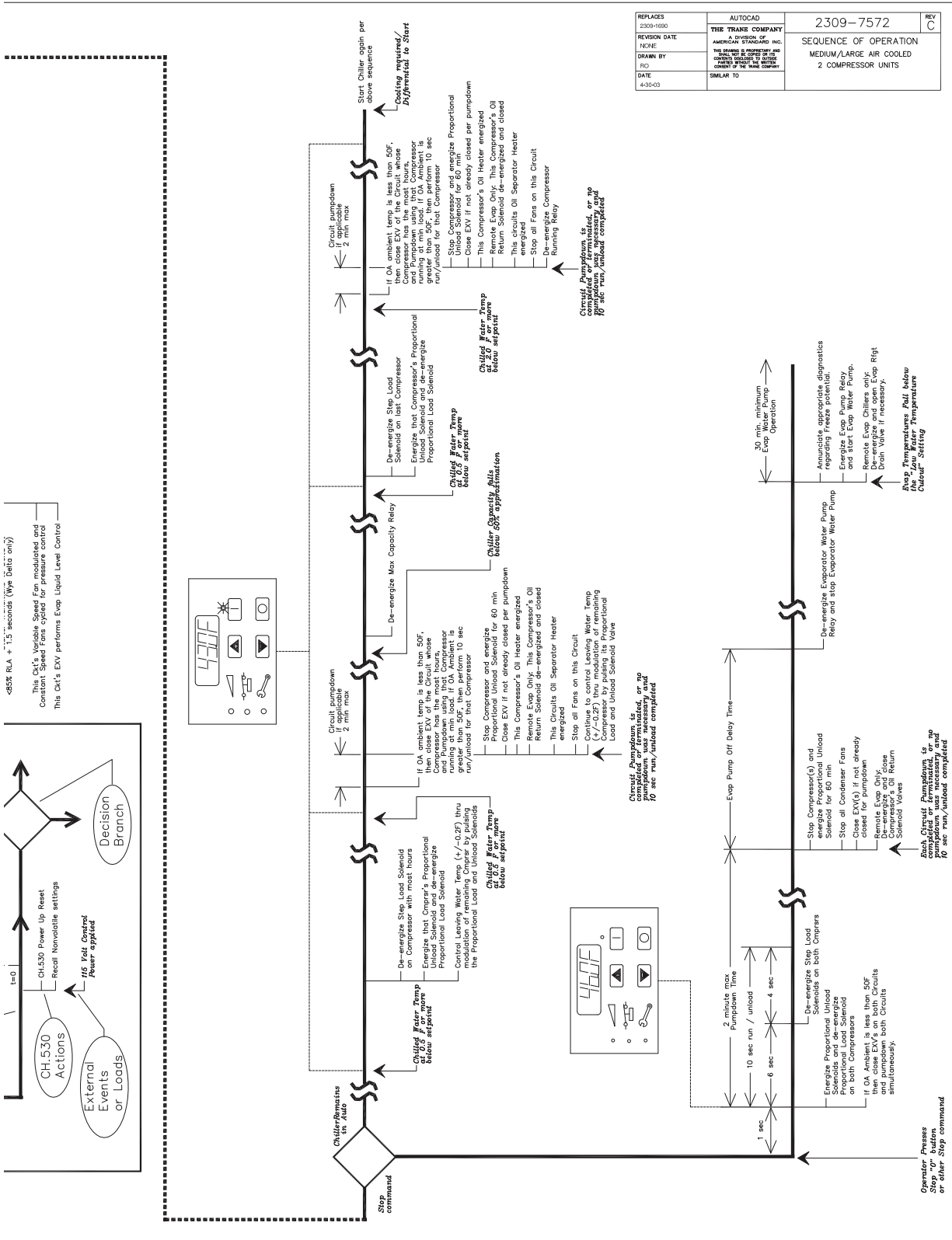

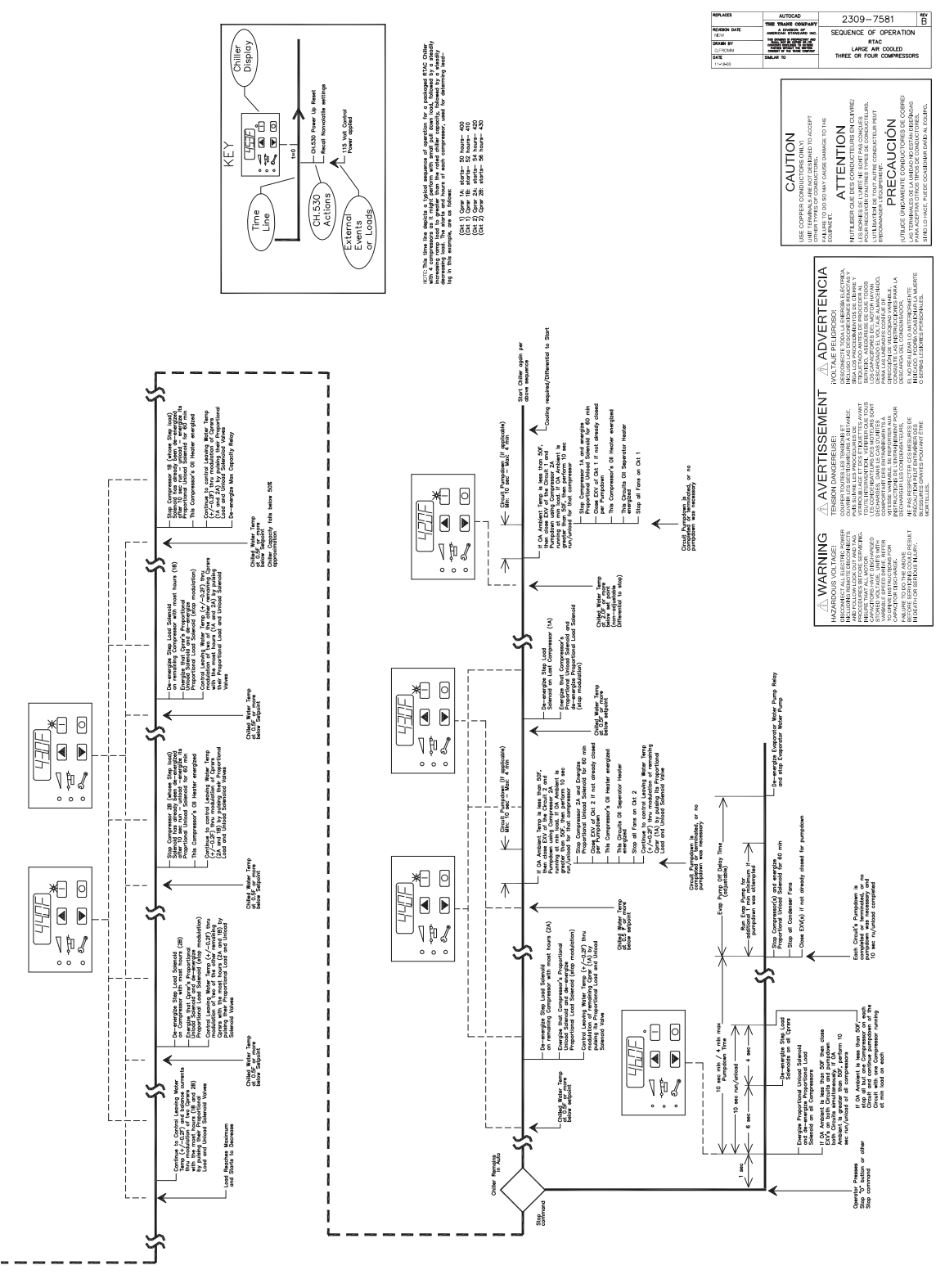



Maintenance

Perform all maintenance procedures and inspections at the recommended intervals. This will prolong the life of the chiller and minimize the possibility of costly failures.

Use the "Operator's Log," such as that show in chapter "Log and Check Sheet," p. 124 to record an operating history for unit. The log serves as a valuable diagnostic tool for service personnel. By observing trends in operating conditions, an operator can anticipate and prevent problem situations before they occur. If unit does not operate properly during maintenance inspections, see "Diagnostics," p. 103.

After unit has been operating for approximately 30 minutes and system has stabilized, check the operating conditions and complete procedures below:

Weekly

While unit is running in stable conditions.

1. Check MP pressure for evaporator, condenser and intermediate oil.
2. Observe liquid line sight glass on EXV.
3. If liquid line sight glass has bubbles measure the subcooling entering the EXV. The subcooling should never be less than 4°F under any circumstances.

Important: A clear sightglass alone does not mean that the system is properly charged. Also check the rest of the system operating conditions.

4. Inspect the entire system for unusual conditions and inspect the condenser coils for dirt and debris. If the coils are dirty, refer to coil cleaning.

Monthly

1. Perform all weekly maintenance procedures.
2. Record the system subcooling.
3. Make any repairs necessary.

Annual

1. Perform all weekly and monthly procedures.
2. Check oil sump oil level while unit is off.

Note: Routine changing of oil is not required. Use an oil analysis to determine condition of oil.

3. Have a qualified laboratory perform a compressor oil analysis to determine system moisture content and acid level. This analysis is a valuable diagnostic tool.
4. Contact a qualified service organization to leak test the chiller, to check operating and safety controls, and to inspect electrical components for deficiencies.
5. Inspect all piping components for leakage and damage. Clean out any inline strainers.

6. Clean and repaint any areas that show signs of corrosion.
7. Clean the condenser coils.

⚠ WARNING

Hazardous Voltage w/Capacitors!

Disconnect all electric power, including remote disconnects and discharge all motor start/run capacitors before servicing. Follow proper lockout/tagout procedures to ensure the power cannot be inadvertently energized. For variable frequency drives or other energy storing components provided by Trane or others, refer to the appropriate manufacturer's literature for allowable waiting periods for discharge of capacitors. Verify with an appropriate voltmeter that all capacitors have discharged. Failure to disconnect power and discharge capacitors before servicing could result in death or serious injury.

For additional information regarding the safe discharge of capacitors, see PROD-SVB06A-EN

8. Check and tighten all electrical connections as necessary.

Refrigerant and Oil Charge Management

Proper oil and refrigerant charge is essential for proper unit operation, unit performance, and environmental protection. Only trained and licensed service personnel should service the chiller.

Table 64 lists baseline measurements for RTAC units running at AHRI standard operating conditions. If chiller measurements vary significantly from values listed below, problems may exist with refrigerant and oil charge levels. Contact your local Trane office.

Note: Low temperature applications units will have values that vary from Table 64. Contact your local Trane office for more information.

Table 64. Typical RTAC baselines (AHRI conditions)

Measurement	Baseline
Evaporator Pressure	49.5 psia
Evaporator Approach	3.5°F
EXV Position	45-50%
Evaporator - entering	54°
Evaporator - leaving	44°
Discharge Superheat	26.6°F
Condenser Pressure	226 psia
Subcooling	18-23°F

Lubrication System

The lubrication system has been designed to keep most of the oil lines filled with oil as long as there is a proper oil level in the oil sump.

Oil Sump Level Check

Oil system consists of the following components:

- Compressor
- Oil separator
- Discharge line with service valve
- Oil line from separator to compressor
- Oil line drain (lowest point in system)
- Oil cooler - optional
- Oil temperature sensor
- Oil line shut off valve with flare service connection
- Oil filter (internal to compressor) with flare fitting service connection and schrader valve
- Oil flow control valve (internal to the compressor after the filter)
- Oil return line from evaporator with shut off valve and strainer

Refer to [Table 1, p. 10](#) through [Table 10, p. 19](#) for the standard oil charge for each circuit.

Note: *It is recommended to check the oil level in the sump using a sight glass or a manometer, attached to charging hoses.*

Table 65. Oil charging data

Circuit (Tons)	Approximate sump oil level after running "normal" conditions (in)	Normal quantity of oil in refrigeration system (evaporator/condenser) lb (gal)
70	7	1.1 (0.14)
85	6	1.1 (0.14)
100	7	1.8 (0.23)
120	7	1.8 (0.23)
170	8	3.5 (0.44)
200	8	3.5 (0.44)
240	8	3.5 (0.44)

1. To **measure oil level**, use the oil drain valve on the oil line and a service valve on the discharge line. This measurement can only be made when the circuit is not running.

Note: *The level is measured from the bottom of the separator and 1" must be subtracted for the thickness of the bottom plate.*

2. The initial oil charge should be approximately at the level in the above chart. This is the approximate oil level if all the oil is in the oil lines, filter and oil sump

and the unit is in vacuum so that there is no refrigerant dissolved in the oil.

3. After the unit has run for a while, the oil level in the sump can vary greatly. However, if the unit has run "normal" conditions for a long time the level should resemble the level in the above chart.
 - +1" to - 4" (25 to -101mm) is acceptable

Important: *If levels are outside these ranges, contact your local Trane office.*

Condenser Maintenance

Condenser Coil Cleaning

⚠ WARNING

Hazardous Chemicals!

Coil cleaning agents can be either acidic or highly alkaline and can burn severely if contact with skin occurs. Handle chemical carefully and avoid contact with skin. ALWAYS wear Personal Protective Equipment (PPE) including goggles or face shield, chemical resistant gloves, boots, apron or suit as required. For personal safety refer to the cleaning agent manufacturer's Materials Safety Data Sheet and follow all recommended safe handling practices. Failure to follow all safety instructions could result in death or serious injury.

Clean the condenser coils at least once a year or more frequently if the unit is in a "dirty" environment. A clean condenser coil will help to maintain chiller operating efficiency. Follow the detergent manufacturer's instructions to avoid damaging the condenser coils.

To clean the condenser coils use a soft brush and a sprayer such as a garden pump type or a high-pressure type. A high quality detergent such as Trane Coil Cleaner (Part No. CHM-00255) is recommended.

Note: *If detergent mixture is strongly alkaline (pH value greater than 8.5, an inhibitor must be added).*

Travel Restraint

WARNING

Falling Off Equipment!

This unit is built with fall restraint slots located on unit top that **MUST** be used during servicing. These slots are to be used with fall restraint equipment that will **not** allow an individual to reach the unit edge. However such equipment will **NOT** prevent falling to the ground, for they are **NOT** designed to withstand the force of a falling individual. Failure to use fall restraint slots and equipment could result in individual falling off the unit which could result in death or serious injury.

This unit is built with travel restraint slots located on unit top that must be used during servicing. See [Figure 48](#).

Figure 48. Roof view - travel restraint slots

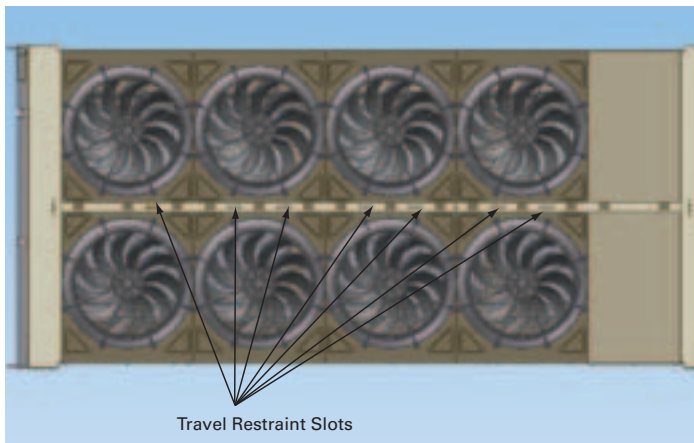



Diagnostics

Legend to Diagnostics Table

Legacy Hex Code: 3 digit hexadecimal code used on all past products to uniquely identify diagnostics.

Diagnostic Name and Source: Name of Diagnostic and its source. Note that this is the exact text used in the User Interface and/or Service Tool displays.

Affects Target: Defines the “target” or what is affected by the diagnostic. Usually either the entire **Chiller**, or a particular **Circuit or Compressor** is affected by the diagnostic (the same one as the source), but in special cases functions are modified or disabled by the diagnostic. **None** implies that there is no direct affect to the chiller, sub components or functional operation.

Severity: Defines the severity of the above effect. **Immediate** means immediate shutdown of the effected portion, **Normal** means normal or friendly shutdown of the effected portion, **Special Mode** means a special mode of operation (limp along) is invoked, but without shutdown, and **Info** means an Informational Note or Warning is generated.

Persistence: Defines whether or not the diagnostic and its effects are to be manually reset (Latched), or can be either manually or automatically reset (Nonlatched).

Active Modes [Inactive Modes]: States the modes or periods of operation that the diagnostic is active in and, as necessary, those modes or periods that it is specifically not active in as an exception to the active modes. The inactive modes are enclosed in brackets, []. Note that the modes used in this column are internal and not generally announced to any of the formal mode displays

Criteria: Quantitatively defines the criteria used in generating the diagnostic and, if nonlatching, the criteria for auto reset. If more explanation is necessary a hot link to the Functional Specification is used.

Reset Level: Defines the lowest level of manual diagnostic reset command which can clear the diagnostic. The manual diagnostic reset levels in order of priority are: **Local** or **Remote**. For example, a diagnostic that has a reset level of Remote, can be reset by either a remote diagnostic reset command or by a local diagnostic reset command.

Help Text: Provides for a brief description of what kind of problems might cause this diagnostic to occur. Both control system component related problems as well as chiller application related problems are addressed (as can possibly be anticipated). These help messages will be updated with accumulated field experience with the chillers.

Starter Diagnostics

Table 66. Starter diagnostics

Diagnostic Name and Source	Affects			Persistence	Active Modes [Inactive Modes]	Criteria	Reset Level
	Target	Severity					
Motor Current Overload - Compressor 1A	Circuit	Immediate		Latch	Cprsr Energized	Compressor current exceeded overload time vs. trip characteristic. For A/C products Must trip = 140% RLA, Must hold=125%, nominal trip 132.5% in 30 seconds	Local
Motor Current Overload - Compressor 1B	Circuit	Immediate		Latch	Cprsr Energized	Compressor current exceeded overload time vs. trip characteristic. For A/C products Must trip = 140% RLA, Must hold=125%, nominal trip 132.5% in 30 seconds	Local
Motor Current Overload - Compressor 2A	Circuit	Immediate		Latch	Cprsr Energized	Compressor current exceeded overload time vs. trip characteristic. For A/C products Must trip = 140% RLA, Must hold=125%, nominal trip 132.5% in 30 seconds	Local
Motor Current Overload - Compressor 2B	Circuit	Immediate		Latch	Cprsr Energized	Compressor current exceeded overload time vs. trip characteristic. For A/C products Must trip = 140% RLA, Must hold=125%, nominal trip 132.5% in 30 seconds	Local
Over Voltage	Chiller	Normal		NonLatch	Pre-Start and Any Ckt(s) Energzd	Nom. trip: 60 seconds at greater than 112.5%, 2.5%, Auto Reset at 109% or less.	Remote
Phase Loss - Compressor 1A	Cprsr	Immediate		Latch	Start Sequence and Run modes	a) No current was sensed on one or two of the current transformer inputs while running or starting (See Nonlatching Power Loss Diagnostic for all three phases lost while running). Must hold = 20% RLA. Must trip = 5% RLA. Time to trip shall be longer than guaranteed reset on Starter Module at a minimum, 3 seconds maximum. Actual design trip point is 10%. The actual design trip time is 2.64 seconds. b) If Phase reversal protection is enabled and current is not sensed on one or more current transformer inputs. Logic will detect and trip in a maximum of 0.3 second from compressor start.	Local



Diagnostics

Table 66. Starter diagnostics (continued)

Diagnostic Name and Source	Affects Target	Severity	Persistence	Active Modes [Inactive Modes]	Criteria	Reset Level
Phase Loss - Compressor 1B	Cprsr	Immediate	Latch	Start Sequence and Run modes	a) No current was sensed on one or two of the current transformer inputs while running or starting (See Nonlatching Power Loss Diagnostic for all three phases lost while running). Must hold = 20% RLA. Must trip = 5% RLA. Time to trip shall be longer than guaranteed reset on Starter Module at a minimum, 3 seconds maximum. Actual design trip point is 10%. The actual design trip time is 2.64 seconds. b) If Phase reversal protection is enabled and current is not sensed on one or more current transformer inputs. Logic will detect and trip in a maximum of 0.3 second from compressor start	Local
Phase Loss - Compressor 2A	Cprsr	Immediate	Latch	Start Sequence and Run modes	a) No current was sensed on one or two of the current transformer inputs while running or starting (See Nonlatching Power Loss Diagnostic for all three phases lost while running). Must hold = 20% RLA. Must trip = 5% RLA. Time to trip shall be longer than guaranteed reset on Starter Module at a minimum, 3 seconds maximum. Actual design trip point is 10%. The actual design trip time is 2.64 seconds. b) If Phase reversal protection is enabled and current is not sensed on one or more current transformer inputs. Logic will detect and trip in a maximum of 0.3 second from compressor start	Local
Phase Loss - Compressor 2B	Cprsr	Immediate	Latch	Start Sequence and Run modes	a) No current was sensed on one or two of the current transformer inputs while running or starting (See Nonlatching Power Loss Diagnostic for all three phases lost while running). Must hold = 20% RLA. Must trip = 5% RLA. Time to trip shall be longer than guaranteed reset on Starter Module at a minimum, 3 seconds maximum. Actual design trip point is 10%. The actual design trip time is 2.64 seconds. b) If Phase reversal protection is enabled and current is not sensed on one or more current transformer inputs. Logic will detect and trip in a maximum of 0.3 second from compressor start	Local
Phase Reversal - Compressor 1A	Cprsr	Immediate	Latch	Compressor energized to transition command [All Other Times]	A phase reversal was detected on the incoming current. On a compressor startup the phase reversal logic must detect and trip in a maximum of .3 second from compressor start.	Local
Phase Reversal - Compressor 1B	Cprsr	Immediate	Latch	Compressor energized to transition command [All Other Times]	A phase reversal was detected on the incoming current. On a compressor startup the phase reversal logic must detect and trip in a maximum of .3 second from compressor start.	Local
Phase Reversal - Compressor 2A	Cprsr	Immediate	Latch	Compressor energized to transition command [All Other Times]	A phase reversal was detected on the incoming current. On a compressor startup the phase reversal logic must detect and trip in a maximum of .3 second from compressor start.	Local
Phase Reversal - Compressor 2B	Cprsr	Immediate	Latch	Compressor energized to transition command [All Other Times]	A phase reversal was detected on the incoming current. On a compressor startup the phase reversal logic must detect and trip in a maximum of .3 second from compressor start.	Local
Power Loss - Compressor 1A	Cprsr	Immediate	NonLatch	All compressor running modes [all compressor starting and non-running modes]	The compressor had previously established currents while running and then all three phases of current were lost. Design: Less than 10% RLA, trip in 2.64 seconds. This diagnostic will preclude the Phase Loss Diagnostic and the Transition Complete Input Opened Diagnostic from being called out. To prevent this diagnostic from occurring with the intended disconnect of main power, the minimum time to trip must be greater than the guaranteed reset time of the Starter module. Note: This diagnostic prevents nuisance latching diagnostics due to a momentary power loss - It does not protect motor/compressor from uncontrolled power reapplication. See Momentary Power Loss Diagnostic for this protection. This diagnostic is not active during the start mode before the transition complete input is proven. Thus a random power loss during a start would result in either a "Starter Fault Type 3" or a "Starter Did Not Transition" latching diagnostic.	Remote

Table 66. Starter diagnostics (continued)

Diagnostic Name and Source	Affects Target	Severity	Persistence	Active Modes [Inactive Modes]	Criteria	Reset Level
Power Loss - Compressor 1B	Cprsr	Immediate	NonLatch	All compressor running modes [all compressor starting and non-running modes]	The compressor had previously established currents while running and then all three phases of current were lost. Design: Less than 10% RLA, trip in 2.64 seconds. This diagnostic will preclude the Phase Loss Diagnostic and the Transition Complete Input Opened Diagnostic from being called out. To prevent this diagnostic from occurring with the intended disconnect of main power, the minimum time to trip must be greater than the guaranteed reset time of the Starter module.	Remote
Power Loss - Compressor 2A	Cprsr	Immediate	NonLatch	All compressor running modes [all compressor starting and non-running modes]	The compressor had previously established currents while running and then all three phases of current were lost. Design: Less than 10% RLA, trip in 2.64 seconds. This diagnostic will preclude the Phase Loss Diagnostic and the Transition Complete Input Opened Diagnostic from being called out. To prevent this diagnostic from occurring with the intended disconnect of main power, the minimum time to trip must be greater than the guaranteed reset time of the Starter module.	Remote
Power Loss - Compressor 2B	Cprsr	Immediate	NonLatch	All compressor running modes [all compressor starting and non-running modes]	The compressor had previously established currents while running and then all three phases of current were lost. Design: Less than 10% RLA, trip in 2.64 seconds. This diagnostic will preclude the Phase Loss Diagnostic and the Transition Complete Input Opened Diagnostic from being called out. To prevent this diagnostic from occurring with the intended disconnect of main power, the minimum time to trip must be greater than the guaranteed reset time of the Starter module.	Remote
Severe Current Imbalance - Compressor 1A	Circuit	Immediate	Latch	All Running Modes	A 30% Current Imbalance has been detected on one phase relative to the average of all 3 phases for 90 continuous seconds.	Local
Severe Current Imbalance - Compressor 1B	Circuit	Immediate	Latch	All Running Modes	A 30% Current Imbalance has been detected on one phase relative to the average of all 3 phases for 90 continuous seconds.	Local
Severe Current Imbalance - Compressor 2A	Circuit	Immediate	Latch	All Running Modes	A 30% Current Imbalance has been detected on one phase relative to the average of all 3 phases for 90 continuous seconds.	Local
Severe Current Imbalance - Compressor 2B	Circuit	Immediate	Latch	All Running Modes	A 30% Current Imbalance has been detected on one phase relative to the average of all 3 phases for 90 continuous seconds.	Local
Starter 1A Dry Run Test	Cprsr	Immediate	Latch	Starter Dry Run Mode	While in the Starter Dry Run Mode either 50% Line Voltage was sensed at the Potential Transformers or 10% RLA Current was sensed at the Current Transformers.	Local
Starter 1B Dry Run Test	Cprsr	Immediate	Latch	Starter Dry Run Mode	While in the Starter Dry Run Mode either 50% Line Voltage was sensed at the Potential Transformers or 10% RLA Current was sensed at the Current Transformers.	Local
Starter 2A Dry Run Test	Cprsr	Immediate	Latch	Starter Dry Run Mode	While in the Starter Dry Run Mode either 50% Line Voltage was sensed at the Potential Transformers or 10% RLA Current was sensed at the Current Transformers.	Local
Starter 2B Dry Run Test	Cprsr	Immediate	Latch	Starter Dry Run Mode	While in the Starter Dry Run Mode either 50% Line Voltage was sensed at the Potential Transformers or 10% RLA Current was sensed at the Current Transformers.	Local
Starter Contactor Interrupt Failure - Compressor 2A	Chiller	Special Mode	Latch	Starter Contactor not Energized [Starter Contactor Energized]	Detected compressor currents greater than 10% RLA on any or all phases when the compressor was commanded off. Detection time shall be 5 second minimum and 10 seconds maximum. On detection and until the controller is manually reset: generate diagnostic, energize the appropriate alarm relay, continue to energize the Evap Pump Output, continue to command the affected compressor off, fully unload the effected compressor and command a normal stop to all other compressors. For as long as current continues, perform liquid level and fan control on the circuit effected.	Local

Diagnostics

Table 66. Starter diagnostics (continued)

Diagnostic Name and Source	Affects Target	Severity	Persistence	Active Modes [Inactive Modes]	Criteria	Reset Level
Starter Contactor Interrupt Failure - Compressor 1A	Chiller	Special Mode	Latch	Starter Contactor not Energized [Starter Contactor Energized]	Detected compressor currents greater than 10% RLA on any or all phases when the compressor was commanded off. Detection time shall be 5 second minimum and 10 seconds maximum. On detection and until the controller is manually reset: generate diagnostic, energize the appropriate alarm relay, continue to energize the Evap Pump Output, continue to command the affected compressor off, fully unload the effected compressor and command a normal stop to all other compressors. For as long as current continues, perform liquid level and fan control on the circuit effected.	Local
Starter Contactor Interrupt Failure - Compressor 1B	Chiller	Special Mode	Latch	Starter Contactor not Energized [Starter Contactor Energized]	Detected compressor currents greater than 10% RLA on any or all phases when the compressor was commanded off. Detection time shall be 5 second minimum and 10 seconds maximum. On detection and until the controller is manually reset: generate diagnostic, energize the appropriate alarm relay, continue to energize the Evap Pump Output, continue to command the affected compressor off, fully unload the effected compressor and command a normal stop to all other compressors. For as long as current continues, perform liquid level and fan control on the circuit effected.	Local
Starter Contactor Interrupt Failure - Compressor 2B	Chiller	Special Mode	Latch	Starter Contactor not Energized [Starter Contactor Energized]	Detected compressor currents greater than 10% RLA on any or all phases when the compressor was commanded off. Detection time shall be 5 second minimum and 10 seconds maximum. On detection and until the controller is manually reset: generate diagnostic, energize the appropriate alarm relay, continue to energize the Evap Pump Output, continue to command the affected compressor off, fully unload the effected compressor and command a normal stop to all other compressors. For as long as current continues, perform liquid level and fan control on the circuit effected.	Local
Starter Did Not Transition - Compressor 1A	Cprsr	Immediate	Latch	On the first check after transition.	The Starter Module did not receive a transition complete signal in the designated time from its command to transition. The must hold time from the Starter Module transition command is 1 second. The Must trip time from the transition command is 6 seconds. Actual design is 2.5 seconds. This diagnostic is active only for Y-Delta, Auto-Transformer, Primary Reactor, and X-Line Starters.	Local
Starter Did Not Transition - Compressor 1B	Cprsr	Immediate	Latch	On the first check after transition.	The Starter Module did not receive a transition complete signal in the designated time from its command to transition. The must hold time from the Starter Module transition command is 1 second. The Must trip time from the transition command is 6 seconds. Actual design is 2.5 seconds. This diagnostic is active only for Y-Delta, Auto-Transformer, Primary Reactor, and X-Line Starters.	Local
Starter Did Not Transition - Compressor 2A	Cprsr	Immediate	Latch	On the first check after transition.	The Starter Module did not receive a transition complete signal in the designated time from its command to transition. The must hold time from the Starter Module transition command is 1 second. The Must trip time from the transition command is 6 seconds. Actual design is 2.5 seconds. This diagnostic is active only for Y-Delta, Auto-Transformer, Primary Reactor, and X-Line Starters.	Local
Starter Did Not Transition - Compressor 2B	Cprsr	Immediate	Latch	On the first check after transition.	The Starter Module did not receive a transition complete signal in the designated time from its command to transition. The must hold time from the Starter Module transition command is 1 second. The Must trip time from the transition command is 6 seconds. Actual design is 2.5 seconds. This diagnostic is active only for Y-Delta, Auto-Transformer, Primary Reactor, and X-Line Starters.	Local
Starter Fault Type I - Compressor 1A	Cprsr	Immediate	Latch	Starting - Y Delta Starters Only	This is a specific starter test where 1M(1K1) is closed first and a check is made to ensure that there are no currents detected by the CT's. If currents are detected when only 1M is closed first at start, then one of the other contactors is shorted.	Local
Starter Fault Type I - Compressor 1B	Cprsr	Immediate	Latch	Starting - Y Delta Starters Only	This is a specific starter test where 1M(1K1) is closed first and a check is made to ensure that there are no currents detected by the CT's. If currents are detected when only 1M is closed first at start, then one of the other contactors is shorted.	Local
Starter Fault Type I - Compressor 2A	Cprsr	Immediate	Latch	Starting - Y Delta Starters Only	This is a specific starter test where 1M(1K1) is closed first and a check is made to ensure that there are no currents detected by the CT's. If currents are detected when only 1M is closed first at start, then one of the other contactors is shorted.	Local

Table 66. Starter diagnostics (continued)

Diagnostic Name and Source	Affects Target	Severity	Persistence	Active Modes [Inactive Modes]	Criteria	Reset Level
Starter Fault Type I - Compressor 2B	Cprsr	Immediate	Latch	Starting - Y Delta Starters Only	This is a specific starter test where 1M(1K1) is closed first and a check is made to ensure that there are no currents detected by the CT's. If currents are detected when only 1M is closed first at start, then one of the other contactors is shorted.	Local
Starter Fault Type II - Compressor 1A	Cprsr	Immediate	Latch	Starting All types of starters	a. This is a specific starter test where the Shorting Contactor (1K3) is individually energized and a check is made to ensure that there are no currents detected by the CT's. If current is detected when only S is energized at Start, then 1M is shorted. b. This test in a. above applies to all forms of starters (Note: It is understood that many starters do not connect to the Shorting Contactor.).	Local
Starter Fault Type II - Compressor 1B	Cprsr	Immediate	Latch	Starting - All types of starters	a. This is a specific starter test where the Shorting Contactor (1K3) is individually energized and a check is made to ensure that there are no currents detected by the CT's. If current is detected when only S is energized at Start, then 1M is shorted. b. This test in a. above applies to all forms of starters (Note: It is understood that many starters do not connect to the Shorting Contactor.).	Local
Starter Fault Type II - Compressor 2A	Cprsr	Immediate	Latch	Starting - All types of starters	a. This is a specific starter test where the Shorting Contactor (1K3) is individually energized and a check is made to ensure that there are no currents detected by the CT's. If current is detected when only S is energized at Start, then 1M is shorted. b. This test in a. above applies to all forms of starters (Note: It is understood that many starters do not connect to the Shorting Contactor.).	Local
Starter Fault Type II - Compressor 2B	Cprsr	Immediate	Latch	Starting - All types of starters	a. This is a specific starter test where the Shorting Contactor (1K3) is individually energized and a check is made to ensure that there are no currents detected by the CT's. If current is detected when only S is energized at Start, then 1M is shorted. b. This test in a. above applies to all forms of starters (Note: It is understood that many starters do not connect to the Shorting Contactor.).	Local
Starter Fault Type III - Compressor 1A	Cprsr	Immediate	Latch	Starting [Adaptive Frequency Starter Type]	As part of the normal start sequence to apply power to the compressor, the Shorting Contactor (1K3) and then the Main Contactor (1K1) were energized. 1.6 seconds later there were no currents detected by the CT's for the last 1.2 Seconds on all three phases. The test above applies to all forms of starters except Adaptive Frequency Drives.	Local
Starter Fault Type III - Compressor 1B	Cprsr	Immediate	Latch	Starting [Adaptive Frequency Starter Type]	As part of the normal start sequence to apply power to the compressor, the Shorting Contactor (1K3) and then the Main Contactor (1K1) were energized. 1.6 seconds later there were no currents detected by the CT's for the last 1.2 seconds on all three phases. The test above applies to all forms of starters except Adaptive Frequency Drives.	Local
Starter Fault Type III - Compressor 2A	Cprsr	Immediate	Latch	Starting [Adaptive Frequency Starter Type]	As part of the normal start sequence to apply power to the compressor, the Shorting Contactor (1K3) and then the Main Contactor (1K1) were energized. 1.6 seconds later there were no currents detected by the CT's for the last 1.2 seconds on all three phases. The test above applies to all forms of starters except Adaptive Frequency Drives.	Local
Starter Fault Type III - Compressor 2B	Cprsr	Immediate	Latch	Starting [Adaptive Frequency Starter Type]	As part of the normal start sequence to apply power to the compressor, the Shorting Contactor (1K3) and then the Main Contactor (1K1) were energized. 1.6 seconds later there were no currents detected by the CT's for the last 1.2 seconds on all three phases. The test above applies to all forms of starters except Adaptive Frequency Drives.	Local
Transition Complete Input Opened - Compressor 1A	Cprsr	Immediate	Latch	All running modes	The Transition Complete input was found to be opened with the compressor motor running after a successful completion of transition. This is active only for Y-Delta, Auto-Transformer, Primary Reactor, and X-Line Starters. To prevent this diagnostic from occurring as the result of a power loss to the contactors, the minimum time to trip must be greater than the trip time for the power loss diagnostic.	Local
Transition Complete Input Opened - Compressor 1B	Cprsr	Immediate	Latch	All running modes	The Transition Complete input was found to be opened with the compressor motor running after a successful completion of transition. This is active only for Y-Delta, Auto-Transformer, Primary Reactor, and X-Line Starters. To prevent this diagnostic from occurring as the result of a power loss to the contactors, the minimum time to trip must be greater than the trip time for the power loss diagnostic.	Local



Diagnostics

Table 66. Starter diagnostics (continued)

Diagnostic Name and Source	Affects Target	Severity	Persistence	Active Modes [Inactive Modes]	Criteria	Reset Level
Transition Complete Input Opened - Compressor 2A	Cprsr	Immediate	Latch	All running modes	The Transition Complete input was found to be opened with the compressor motor running after a successful completion of transition. This is active only for Y-Delta, Auto-Transformer, Primary Reactor, and X-Line Starters. To prevent this diagnostic from occurring as the result of a power loss to the contactors, the minimum time to trip must be greater than the trip time for the power loss diagnostic.	Local
Transition Complete Input Opened - Compressor 2B	Cprsr	Immediate	Latch	All running modes	The Transition Complete input was found to be opened with the compressor motor running after a successful completion of transition. This is active only for Y-Delta, Auto-Transformer, Primary Reactor, and X-Line Starters. To prevent this diagnostic from occurring as the result of a power loss to the contactors, the minimum time to trip must be greater than the trip time for the power loss diagnostic.	Local
Transition Complete Input Shorted - Compressor 1A	Cprsr	Immediate	Latch	Pre-Start	The Transition Complete input was found to be shorted before the compressor was started. This is active for all electromechanical starters.	Local
Transition Complete Input Shorted - Compressor 1B	Cprsr	Immediate	Latch	Pre-Start	The Transition Complete input was found to be shorted before the compressor was started. This is active for all electromechanical starters.	Local
Transition Complete Input Shorted - Compressor 2A	Cprsr	Immediate	Latch	Pre-Start	The Transition Complete input was found to be shorted before the compressor was started. This is active for all electromechanical starters.	Local
Transition Complete Input Shorted - Compressor 2B	Cprsr	Immediate	Latch	Pre-Start	The Transition Complete input was found to be shorted before the compressor was started. This is active for all electromechanical starters.	Local
Under Voltage	Chiller	Normal	NonLatch	Pre-Start and Any Ckt(s) Energzd	Nom. trip: 60 seconds at less than 87.5%, 2.8% at 200V 1.8% at 575V, Auto Reset at 90% or greater.	Remote

Main Processor Diagnostics

Table 67. Main processor diagnostics

Diagnostic Name	Affects Target	Severity	Persistence	Active Modes [Inactive Modes]	Criteria	Reset Level
BAS Communication Lost	None	Special	NonLatch	All	The BAS was setup as "installed" at the MP and the Comm 3 Iliid lost communications with the BAS for 15 contiguous minutes after it had been established. Refer to Section on Setpoint Arbitration to determine how setpoints and operating modes may be effected by the comm loss. The chiller follows the value of the Tracer Default Run Command which can be previously written by Tracer and stored nonvolatitely by the MP (either use local or shutdown).	Remote
BAS Failed to Establish Communication	None	Special	NonLatch	At power-up	The BAS was setup as "installed" and the BAS did not communicate with the MP within 15 minutes after power-up. Refer to Section on Setpoint Arbitration to determine how setpoints and operating modes may be effected. Note: The original requirement for this was 2 minutes, but was implemented at 15 minutes for RTAC.	Remote
Check Clock	Chiller	Info	Latch	All	The real time clock had detected loss of its oscillator at some time in the past. Check / replace battery? This diagnostic can be effectively cleared only by writing a new value to the chiller's time clock using the TechView or DynaView's "set chiller time" functions.	Remote
Condenser Fan Variable Speed Drive Fault - Circuit 1 (Drive 1)	All inverters on this circuit	Special Mode	Latch	Prestart and Running w/ Variable Spd Fan enabled	The MP has received a fault signal from the respective condenser fan Variable Speed Inverter Drive, and unsuccessfully attempted (5 times within 1 minute of each other) to clear the fault. The 4th attempt removes power from the inverter to create a power up reset. If the fault does not clear, the MP will revert to constant speed operation without the use of the inverter's fan. The inverter must be manually bypassed, and fan outputs rebound, for full fixed speed fan operation.	Remote

Table 67. Main processor diagnostics (continued)

Diagnostic Name	Affects Target	Severity	Persist-ence	Active Modes		Criteria	Reset Level
				[Inactive Modes]			
Condenser Fan Variable Speed Drive Fault - Circuit 1 Drive 2	All inverters on this circuit	Special Mode	Latch	Prestart and Running w/ Variable Spd Fan enabled		The MP has received a fault signal from the respective condenser fan Variable Speed Inverter Drive, and unsuccessfully attempted (5 times within 1 minute of each other) to clear the fault. The 4th attempt removes power from the inverter to create a power up reset. If the fault does not clear, the MP will revert to constant speed operation without the use of the inverter's fan. The inverter must be manually bypassed, and fan outputs rebound, for full fixed speed fan operation.	Remote
Condenser Fan Variable Speed Drive Fault - Circuit 2 (Drive 1)	All inverters on this circuit	Special Mode	Latch	Prestart and Running w/ Variable Spd Fan enabled		The MP has received a fault signal from the respective condenser fan Variable Speed Inverter Drive, and unsuccessfully attempted (5 times within 1 minute of each other) to clear the fault. The 4th attempt removes power from the inverter to create a power up reset. If the fault does not clear, the MP will revert to constant speed operation without the use of the inverter's fan. The inverter must be manually bypassed, and fan outputs rebound, for full fixed speed fan operation.	Remote
Condenser Fan Variable Speed Drive Fault - Circuit 2 (Drive 2)	All inverters on this circuit	Special Mode	Latch	Prestart and Running w/ Variable Spd Fan enabled		The MP has received a fault signal from the respective condenser fan Variable Speed Inverter Drive, and unsuccessfully attempted (5 times within 1 minute of each other) to clear the fault. The 4th attempt removes power from the inverter to create a power up reset. If the fault does not clear, the MP will revert to constant speed operation without the use of the inverter's fan. The inverter must be manually bypassed, and fan outputs rebound, for full fixed speed fan operation.	Remote
Condenser Refrigerant Pressure Transducer - Circuit 1	Circuit	Immediate	Latch	All	Bad Sensor or LLID		Remote
Condenser Refrigerant Pressure Transducer - Circuit 2	Circuit	Immediate	Latch	All	Bad Sensor or LLID		Remote
Emergency Stop	Chiller	Immediate	Latch	All	a. EMERGENCY STOP input is open. An external interlock has tripped. Time to trip from input opening to unit stop shall be 0.1 to 1.0 seconds.		Local
Evaporator Entering Water Temperature Sensor	Chilled Water Reset	Info	Latch	All	Bad Sensor or LLID a. Normal operation, no effects on control. b. Chiller shall remove any Return or Constant Return Chilled Water Reset, if it was in effect. Apply slew rates per Chilled Water Reset spec.		Remote
Evaporator Leaving Water Temperature Sensor	Chiller	Normal	Latch	All	Bad Sensor or LLID		Remote
Evaporator Liquid Level Sensor - Circuit 1	Circuit	Immediate	Latch	All	Bad Sensor or LLID		Remote
Evaporator Liquid Level Sensor - Circuit 2	Circuit	Immediate	Latch	All	Bad Sensor or LLID		Remote
Evaporator Rfgt Drain - Circuit 1	Circuit	NA	Latch	Circuit non-running modes [Drain Valve commanded closed]	This diagnostic is effective only with Remote Evap units. The liquid level of the respective evaporator was not seen to be below the level of -21.2 mm within 5 minutes of the commanded opening of its Drain Valve Solenoid. The diagnostic will not be active if the drain valve is commanded closed.		Remote
Evaporator Rfgt Drain - Circuit 2	Circuit	NA	Latch	Circuit non-running modes [Drain Valve commanded closed]	This diagnostic is effective only with Remote Evap units. The liquid level of the respective evaporator was not seen to be below the level of -21.2 mm within 5 minutes of the commanded opening of its Drain Valve Solenoid Valve. The diagnostic will not be active if the drain valve is commanded closed.		Remote
Evaporator Water Flow (Entering Water Temp)	Chiller	Immediate Shutdown	Latching	Any Ckt Energized [No Ckts Energized]	The entering evaporator water temp fell below the leaving evaporator water temp by more than 2°F for 180°F-sec, minimum trip time 1 minute.		Remote
Evaporator Water Flow (High Approach Temperature)- Circuit 1	Chiller	Immediate Shutdown	Latching	Ckt Energized [Ckt Not Energized]	Large evaporator approach temps, low evap sat temps, and presence of liquid refrigerant, suggest this circuit is running with no or reversed evaporator water flow.		Remote

Diagnosics

Table 67. Main processor diagnostics (continued)

Diagnostic Name	Affects Target	Severity	Persist-ence	Active Modes		Criteria	Reset Level
				[Inactive Modes]			
Evaporator Water Flow (High Approach Temperature)- Circuit 2	Chiller	Immediate Shutdown	Latching	Ckt Energized [Ckt Not Energized]		Large evaporator approach temps, low evap sat temps, and presence of liquid refrigerant, suggest this circuit is running with no or reversed evaporator water flow.	Remote
Evaporator Water Flow Lost	Chiller	Immediate	NonLatch	Whenever Evap Pump is commanded on due to Auto mode and certain off-cycle diagnostics		a. The Evaporator water flow switch input was open for more than 6-10 sec (HV binary input) or 20-25* sec (for factory mtd low voltage binary input) b. This diagnostic does not de-energize the evap pump output c. 6-10 seconds of contiguous flow shall clear this diagnostic. d. Even though the pump times out in the STOP modes, this diagnostic shall not be called out in the STOP modes, (with the exception of pump override due to certain off-cycle diagnostics). * could be longer if water temps are rapidly changing warmer	Remote
Evaporator Water Flow Overdue	Chiller	Normal	NonLatch	Whenever Evap Pump is commanded on due to Auto mode and certain off-cycle diagnostics		Evaporator water flow was not proven within 4:15 (RTAC Rev 20 and earlier) or 20:00 (RTAC Rev 21) of the Evaporator water pump relay being energized. With SW Rev 17.0 and earlier, the diagnostic will de-energize the Evaporator Water Pump output. It will be re-energized if the diagnostic clears with the return of flow and the chiller will be allowed to restart normally (to accommodate external control of pump) With SW Rev 18.0 and later, the pump command status will not be effected. In the case of certain "Off-cycle" diagnostics in which the pump is overridden to on, the delay to callout of the diagnostic is shortened to 4:15.	Remote
External Chilled Water Setpoint	None	Info	NonLatch	All		a. Function Not "Enabled": no diagnostics. b. "Enabled ": Out-Of-Range Low or Hi or bad LLID, set diagnostic, default CWS to next level of priority (e.g. Front Panel SetPoint). This Info diagnostic will automatically reset if the input returns to the normal range.	Remote
External Current Limit Setpoint	None	Info	NonLatch	All		a. Not "Enabled": no diagnostics. b. "Enabled ": Out-Of-Range Low or Hi or bad LLID, set diagnostic, default CLS to next level of priority (e.g. Front Panel SetPoint). This Info diagnostic will automatically reset if the input returns to the normal range.	Remote
High Differential Refrigerant Pressure - Circuit 1	Circuit	Normal	Latch	Cprsr Energized		The system differential pressure for the respective circuit was above 275 Psid for 2 consecutive samples or more than 10 seconds.	Remote
High Differential Refrigerant Pressure - Circuit 2	Circuit	Normal	Latch	Cprsr Energized		The system differential pressure for the respective circuit was above 275 Psid for 2 consecutive samples or more than 10 seconds	Remote
High Evaporator Liquid Level - Circuit 1	Circuit	Normal	Latch	Starter Contactor Energized [all Stop modes]		The liquid level sensor is seen to be at or near its high end of range for 80 contiguous minutes while the compressor is running. (The diagnostic timer will hold, but not clear when the circuit is off). Design: 80% or more of bit count corresponding to +21.2 mm or more liquid level for 80 minutes)	Remote
High Evaporator Liquid Level - Circuit 2	Circuit	Normal	Latch	Starter Contactor Energized [all Stop modes]		The liquid level sensor is seen to be at or near its high end of range for 80 contiguous minutes while the compressor is running. (The diagnostic timer will hold, but not clear when the circuit is off). Design: 80% or more of bit count corresponding to +21.2 mm or more liquid level for 80 minutes)	Remote
High Evaporator Refrigerant Pressure	Chiller	Immediate	NonLatch	All		The evaporator refrigerant pressure of either circuit has risen above 190 psig. The evaporator water pump relay will be de-energized to stop the pump regardless of why the pump is running (and the chiller will be prevented from starting) The diagnostic will auto reset and the pump will return to normal control when all of the evaporator pressures fall below 185 psig. The primary purpose is to stop the evaporator water pump and its associated pump heat from causing refrigerant side pressures, close to the evaporator relief valve setting, when the chiller is not running, such as could occur with Evap Water Flow Overdue or Evaporator Water Flow Loss Diagnostics.	Remote

Table 67. Main processor diagnostics (continued)

Diagnostic Name	Affects Target	Severity	Persist-ence	Active Modes		Criteria	Reset Level
				[Inactive Modes]			
High Evaporator Water Temperature	Chiller	Info and Special Action (Pre RTAC Refresh Rev 39)	NonLatch	Only effective if either 1)Evap Wtr Flow Overdue, 2)Evap Wtr Flow Loss, or 3)Low Evap Rfght Temp,-Unit Off, diagnostic is active.		The leaving water temperature exceeded the high evap water temp limit (TV service menu settable -default 105F) for 15 continuous seconds. The evaporator water pump relay will be de-energized to stop the pump but only if it is running due to one of the diagnostics listed on the left. The diagnostic will auto reset and the pump will return to normal control when the temperature falls 5 F below the trip setting. The primary purpose is to stop the evaporator water pump and its associated pump heat from causing excessive waterside temperatures and waterside pressures when the chiller is not running but the evap pump is on due to either Evap Water Flow Overdue, Evaporator Water Flow Loss, or Low Evap Temp - Unit Off Diagnostics. This diagnostic will not auto clear solely due to the clearing of the enabling diagnostic.	Remote
High Evaporator Water Temperature	Chiller	Immediate Shutdown (Beginning with RTAC Refresh Rev 39)	Latch	Only effective if either 1)Evap Wtr Flow Overdue 2)Evap Wtr Flow Loss, or 3)Low Evap Rfght Temp,-Unit Off, diagnostic is active.		The leaving water temperature exceeded the high evap water temp limit (TV service menu settable -default 105F) for 15 continuous seconds, with one of the three diagnostics on the left already active. The evaporator water pump relay will be de-energized to stop the pump. The diagnostic can only be cleared by a manual reset and will clear regardless of the temperature. (although the diagnostic may reoccur based on the trip criteria). The primary purpose is to stop the evaporator water pump and its associated pump heat from causing excessive waterside temperatures (and waterside pressures) when the chiller is not running but the evap pump is on due to a pump override to "on" (as can be caused by a bad flow switches failure to close and prove flow).	Local
High Oil Temperature - Compressor 1B	Cprsr 1B	Immediate	Latch	All		The respective oil temperature as supplied to the compressor, exceeded 200 F for 2 consecutive samples or for over 10 seconds. Note: As part of the Compressor High Temperature Limit Mode (aka Minimum Limit), the running compressor's female load step will be forced loaded when its oil temperature exceeds 190F and returned to normal control when the oil temperature falls below 170 F.	Remote
High Oil Temperature - Compressor 2B	Cprsr 2B	Immediate	Latch	All		The respective oil temperature as supplied to the compressor, exceeded 200 F for 2 consecutive samples or for over 10 seconds. Note: As part of the Compressor High Temperature Limit Mode (aka Minimum Limit), the running compressor's female load step will be forced loaded when its oil temperature exceeds 190F and returned to normal control when the oil temperature falls below 170 F.	Remote
High Oil Temperature - Compressor 1A	Cprsr 1A	Immediate	Latch	All		The respective oil temperature as supplied to the compressor, exceeded 200 F for 2 consecutive samples or for over 10 seconds. Note: As part of the Compressor High Temperature Limit Mode (aka Minimum Limit), the running compressor's female load step will be forced loaded when its oil temperature exceeds 190F and returned to normal control when the oil temperature falls below 170 F.	Remote
High Oil Temperature - Compressor 2A	Cprsr 2A	Immediate	Latch	All		The respective oil temperature as supplied to the compressor, exceeded 200 F for 2 consecutive samples or for over 10 seconds. Note: As part of the Compressor High Temperature Limit Mode (aka Minimum Limit), the running compressor's female load step will be forced loaded when its oil temperature exceeds 190F and returned to normal control when the oil temperature falls below 170 F.	Remote
High Pressure Cutout - Compressor 1A	Circuit	Immediate	Latch	All		A high pressure cutout was detected on Compressor 1A; trip at 315 ± 5 PSIG. Note: Other diagnostics that may occur as an expected consequence of the HPC trip will be suppressed from annunciation. These include Phase Loss, Power Loss, and Transition Complete Input Open.	Local
High Pressure Cutout - Compressor 1B	Circuit	Immediate	Latch	All		A high pressure cutout was detected on Compressor 1A; trip at 315 ± 5 PSIG. Note: Other diagnostics that may occur as an expected consequence of the HPC trip will be suppressed from annunciation. These include Phase Loss, Power Loss, and Transition Complete Input Open.	Local



Diagnostics

Table 67. Main processor diagnostics (continued)

Diagnostic Name	Affects Target	Severity	Persist-ence	Active Modes		Criteria	Reset Level
				[Inactive Modes]			
High Pressure Cutout - Compressor 2A	Circuit	Immediate	Latch	All		A high pressure cutout was detected on Compressor 1A; trip at 315 ± 5 PSIG. Note: Other diagnostics that may occur as an expected consequence of the HPC trip will be suppressed from announcement. These include Phase Loss, Power Loss, and Transition Complete Input Open.	Local
High Pressure Cutout - Compressor 2B	Circuit	Immediate	Latch	All		A high pressure cutout was detected on Compressor 1A; trip at 315 ± 5 PSIG. Note: Other diagnostics that may occur as an expected consequence of the HPC trip will be suppressed from announcement. These include Phase Loss, Power Loss, and Transition Complete Input Open.	Local
Intermediate Oil Pressure Transducer - Compressor 1A	Cprsr 1A	Immediate	Latch	All		Bad Sensor or LLID	Remote
Intermediate Oil Pressure Transducer - Compressor 1B	Cprsr 1B	Immediate	Latch	All		Bad Sensor or LLID	Remote
Intermediate Oil Pressure Transducer - Compressor 2A	Cprsr 2A	Immediate	Latch	All		Bad Sensor or LLID	Remote
Intermediate Oil Pressure Transducer - Compressor 2B	Cprsr 2B	Immediate	Latch	All		Bad Sensor or LLID	Remote
Low Chilled Water Temp: Unit Off	Evap Pump	Special Mode	NonLatch	Unit in Stop Mode, or in Auto Mode and No Ckt(s) Energzd [Any Ckt Energzd]		The leaving Evaporator water temp. fell below the leaving water temp cutout setting for 30 degree F seconds while the Chiller is in the Stop mode, or in Auto mode with no compressors running. Energize Evap Water pump Relay until diagnostic auto resets, then return to normal evap pump control. Automatic reset occurs when the temp rises 2°F (1.1°C) above the cutout setting for 30 minutes.	Remote
Low Chilled Water Temp: Unit On	Chiller	Immediate and Special Mode	NonLatch	Any Ckts] Energzd [No Ckt(s) Energzd]		The evaporator water temp. fell below the cutout setpoint for 30 degree F Seconds while the compressor was running. Automatic reset occurs when the temperature rises 2°F (1.1°C) above the cutout setting for 2 minutes. This diagnostic shall not de-energize the Evaporator Water Pump Output.	Remote
Low Differential Refrigerant Pressure - Circuit 1	Circuit	Immediate	Latch	Cprsr Energized		The system differential pressure for the respective circuit was below 35 Psid for more than 2000 Psid-sec with either a 1 minute (single cprsr circuit) or 2.5 minute (manifolded cprsr circuit) ignore time from the start of the circuit.	Remote
Low Differential Refrigerant Pressure - Circuit 2	Circuit	Immediate	Latch	Cprsr Energized		The system differential pressure for the respective circuit was below 35 Psid for more than 2000 Psid-sec with either a 1 minute (single cprsr circuit) or 2.5 minute (manifolded cprsr circuit) ignore time from the start of the circuit.	Remote
Low Evaporator Liquid Level - Circuit 1	None	Info	NonLatch	Starter Contactor Energized [all Stop modes]		The liquid level sensor is seen to be at or near its low end of range for 80 contiguous minutes while the compressor is running. Design: 20% or less of bit count corresponding to -21.2 mm or less liquid level for 80 minutes)	Remote
Low Evaporator Liquid Level - Circuit 2	None	Info	NonLatch	Starter Contactor Energized [all Stop modes]		The liquid level sensor is seen to be at or near its low end of range for 80 contiguous minutes while the compressor is running. Design: 20% or less of bit count corresponding to -21.2 mm or less liquid level for 80 minutes)	Remote
Low Evaporator Refrigerant Temperature - Circuit 1	Circuit	Immediate	Latch	All Ckt Running Modes		The inferred Saturated Evap Refrigerant Temperature (calculated from suction pressure transducer dropped below the Low Refrigerant Temperature Cutout Setpoint for 1125 F-sec with a 8 F-sec/sec max integral rate applied during circuit startup transient (or 4°F-s/s if manifolded and only one cprsr running) while the circuit was running early in the circuit's cycle. The minimum LRTC setpoint is -5 F (18.7 Psia) the point at which oil separates from the refrigerant. During the time that the trip integral is non zero, the unload solenoid(s) of the running compressors on the circuit, shall be energized continuously and the load solenoid shall be off. Normal load/unload operation will be resumed if the trip integral decays to zero by temps above the cutout setpoint. The integral is held nonvolatily though power down, is continuously calculated, and can decay during the circuit's off cycle as conditions warrant.	Remote

Table 67. Main processor diagnostics (continued)

Diagnostic Name	Affects Target	Severity	Persist-ence	Active Modes [Inactive Modes]	Criteria	Reset Level
Low Evaporator Refrigerant Temperature - Circuit 2	Circuit	Immediate	Latch	All Ckt Running Modes	The inferred Saturated Evap Refrigerant Temperature (calculated from suction pressure transducer dropped below the Low Refrigerant Temperature Cutout Setpoint for 1125 F-sec with a 8 F-sec/sec max integral rate applied during circuit startup transient (or 4°F-s/s if manifolded and only one cprsr running) while the circuit was running early in the circuit's cycle. The minimum LRTC setpoint is -5 F (18.7 Psia) the point at which oil separates from the refrigerant. During the time that the trip integral is non zero, the unload solenoid(s) of the running compressors on the circuit, shall be energized continuously and the load solenoid shall be off. Normal load/unload operation will be resumed if the trip integral decays to zero by temps above the cutout setpoint. The integral is held nonvolatily though power down, is continuously calculated, and can decay during the circuit's off cycle as conditions warrant.	Remote
Low Evaporator Temp - Ckt 1: Unit Off	Evap Pump	Special Mode	NonLatch	Unit in Stop Mode, or in Auto Mode and No Ckt's Energzd [Any Ckt Energzd]	Any of the evap sat temps fell below the water temp cutout setting while the respective evap liquid level was greater than -21.2mm for 150 degree F seconds while Chiller is in the Stop mode, or in Auto mode with no compressors running. Energize Evap Water pump Relay until diagnostic auto resets, then return to normal evap pump control. Automatic reset occurs when either the evap temp rises 2 F (1.1 C) above the cutout setting or the liquid level falls below -21.2mm for 30 minutes	Remote
Low Evaporator Temp - Ckt 2: Unit Off	Evap Pump	Special Mode	NonLatch	Unit in Stop Mode, or in Auto Mode and No Ckt's Energzd [Any Ckt Energzd]	Any of the evap sat temps fell below the water temp cutout setting while the respective evap liquid level was greater than -21.2mm for 150 degree F seconds while Chiller is in the Stop mode, or in Auto mode with no compressors running. Energize Evap Water pump Relay until diagnostic auto resets, then return to normal evap pump control. Automatic reset occurs when either the evap temp rises 2 F (1.1 C) above the cutout setting or the liquid level falls below -21.2mm for 30 minutes	Remote
Low Oil Flow - Compressor 1A	Cprsr	Immediate	Latch	Cprsr Energized and Delta P above 35 Psid	The intermediate oil pressure transducer for this compressor was out of the acceptable pressure range for 15 seconds, while the Delta Pressure was greater than 35 Psid.: Acceptable range is $0.50 > (PC-PI) / (PC-PE)$ for the first 2.5 minutes of operation, and $0.25 > (PC-PI) / (PC-PE)$ thereafter,	Local
Low Oil Flow - Compressor 1B	Cprsr	Immediate	Latch	Cprsr Energized and Delta P above 35 Psid	The intermediate oil pressure transducer for this compressor was out of the acceptable pressure range for 15 seconds, while the Delta Pressure was greater than 35 Psid.: Acceptable range is $0.50 > (PC-PI) / (PC-PE)$ for the first 2.5 minutes of operation, and $0.25 > (PC-PI) / (PC-PE)$ thereafter,	Local
Low Oil Flow - Compressor 2A	Cprsr	Immediate	Latch	Cprsr Energized and Delta P above 35 Psid	The intermediate oil pressure transducer for this compressor was out of the acceptable pressure range for 15 seconds, while the Delta Pressure was greater than 35Psid.: Acceptable range is $0.50 > (PC-PI) / (PC-PE)$ for the first 2.5 minutes of operation, and $0.25 > (PC-PI) / (PC-PE)$ thereafter,.	Local
Low Oil Flow - Compressor 2B	Cprsr	Immediate	Latch	Cprsr Energized and Delta P above 35 Psid	The intermediate oil pressure transducer for this compressor was out of the acceptable pressure range for 15 seconds, while the Delta Pressure was greater than 35 Psid.: Acceptable range is $0.50 > (PC-PI) / (PC-PE)$ for the first 2.5 minutes of operation, and $0.25 > (PC-PI) / (PC-PE)$ thereafter,	Local
Low Suction Refrigerant Pressure - Circuit 1	Circuit	Immediate	Latch	Cprsr Prestart and Cprsr Energized	a. The Suction Refrigerant Pressure (or either of the compressor suction pressures) dropped below 10 Psia just prior to compressor start (after EXV preposition). b. The pressure fell below 16 Psia while running after the ignore time had expired, or fell below 10 Psia (or 5 Psia in sftw prior to Oct'02) before the ignore time had expired. The ignore time is function of outdoor air temperature. Note: Part b. is identical to Low Evaporator Refrigerant Temperature diagnostic except for the trip integral and trip point settings.	Local
Low Suction Refrigerant Pressure - Circuit 2	Circuit	Immediate	Latch	Cprsr Prestart and Cprsr Energized	a. The Suction Refrigerant Pressure (or either of the compressor suction pressures) dropped below 10 Psia just prior to compressor start (after EXV preposition). b. The pressure fell below 16 Psia while running after the ignore time had expired, or fell below 10 Psia (or 5 Psia in sftw prior to Oct'02) before the ignore time had expired. The ignore time is function of outdoor air temperature. Note: Part b. is identical to Low Evaporator Refrigerant Temperature diagnostic except for the trip integral and trip point settings.	Local



Diagnostics

Table 67. Main processor diagnostics (continued)

Diagnostic Name	Affects Target	Severity	Persist-ence	Active Modes [Inactive Modes]	Criteria	Reset Level
Low Suction Refrigerant Pressure - Cprsr 1B	Circuit	Immediate	Latch	Cprsr Prestart and Cprsr Energized	a. The Suction Refrigerant Pressure (or either of the compressor suction pressures) dropped below 10 Psia just prior to compressor start (after EXV preposition). b. The pressure fell below 16 Psia while running after the ignore time had expired, or fell below 10 Psia (or 5 Psia in sftw prior to Oct'02) before the ignore time had expired. The ignore time is function of outdoor air temperature. Note: Part b. is identical to Low Evaporator Refrigerant Temperature diagnostic except for the trip integral and trip point settings.	Local
Low Suction Refrigerant Pressure - Cprsr 2B	Circuit	Immediate	Latch	Cprsr Prestart and Cprsr Energized	a. The Suction Refrigerant Pressure (or either of the compressor suction pressures) dropped below 10 Psia just prior to compressor start (after EXV preposition). b. The pressure fell below 16 Psia while running after the ignore time had expired, or fell below 10 Psia (or 5 Psia in sftw prior to Oct'02) before the ignore time had expired. The ignore time is function of outdoor air temperature. Note: Part b. is identical to Low Evaporator Refrigerant Temperature diagnostic except for the trip integral and trip point settings.	Local
MP Application Memory CRC Error	Chiller	Immediate	Latch	All Modes	Memory error criteria TBD	Remote
MP: Could not Store Starts and Hours	None	Info	Latch	All	MP has determined there was an error with the previous power down store. Starts and Hours may have been lost for the last 24 hours.	Remote
MP: Invalid Configuration	None	Immediate	Latch	All	MP has an invalid configuration based on the current software installed	Remote
MP: Non-Volatile Block Test Error	None	Info	Latch	All	MP has determined there was an error with a block in the Non-Volatile memory. Check settings.	Remote
MP: Non-Volatile Memory Reformat	None	Info	Latch	All	MP has determined there was an error in a sector of the Non-Volatile memory and it was reformatted. Check settings.	Remote
MP: Reset Has Occurred	None	Info	NonLatch	All	The main processor has successfully come out of a reset and built its application. A reset may have been due to a power up, installing new software or configuration. This diagnostic is immediately and automatically cleared and thus can only be seen in the Historic Diagnostic List in TechView	Remote
Oil Flow Fault - Compressor 1A	Circuit	Immediate	Latch	Starter Contactor Energized [all Stop modes]	The Intermediate Oil Pressure Transducer for this cprsr is reading a pressure either above its respective circuit's Condenser Pressure by 15 Psia or more, or below its respective Suction Pressure 10 Psia or more for 30 seconds continuously.	Local
Oil Flow Fault - Compressor 1B	Circuit	Immediate	Latch	Starter Contactor Energized [all Stop modes]	The Intermediate Oil Pressure Transducer for this cprsr is reading a pressure either above its respective circuit's Condenser Pressure by 15 Psia or more, or below its respective Suction Pressure 10 Psia or more for 30 seconds continuously.	Local
Oil Flow Fault - Compressor 2A	Circuit	Immediate	Latch	Starter Contactor Energized [all Stop modes]	The Intermediate Oil Pressure Transducer for this cprsr is reading a pressure either above its respective circuit's Condenser Pressure by 15 Psia or more, or below its respective Suction Pressure 10 Psia or more for 30 seconds continuously.	Local
Oil Flow Fault - Compressor 2B	Circuit	Immediate	Latch	Starter Contactor Energized [all Stop modes]	The Intermediate Oil Pressure Transducer for this cprsr is reading a pressure either above its respective circuit's Condenser Pressure by 15 Psia or more, or below its respective Suction Pressure 10 Psia or more for 30 seconds continuously.	Local
Oil Temperature Sensor - Cprsr 1B	Circuit	Normal	Latch	All	Bad Sensor or LLID	Remote
Oil Temperature Sensor - Cprsr 2B	Circuit	Normal	Latch	All	Bad Sensor or LLID	Remote
Oil Temperature Sensor -Cprsr 1A	Circuit	Normal	Latch	All	Bad Sensor or LLID	Remote
Oil Temperature Sensor -Cprsr 2A	Circuit	Normal	Latch	All	Bad Sensor or LLID	Remote
Outdoor Air Temperature Sensor	Chiller	Normal	Latch	All	Bad Sensor or LLID. Note that if this diagnostic occurs, operational pumpdown will be performed regardless of the last valid temperature	Remote
Pumpdown Terminated - Circuit 1	None	Info	NonLatch	Pumpdown Mode	The pumpdown cycle for this circuit was terminated abnormally due to excessive time or due to a specific set of diagnostic criteria - but w/o associated latching diagnostics	Remote

Table 67. Main processor diagnostics (continued)

Diagnostic Name	Affects Target	Severity	Persist-ence	Active Modes		Criteria	Reset Level
				[Inactive Modes]			
Pumpdown Terminated - Circuit 2	None	Info	NonLatch	Pumpdown Mode		The pumpdown cycle for this circuit was terminated abnormally due to excessive time or due to a specific set of diagnostic criteria - but w/o associated latching diagnostics	Remote
Software Error 1001: Call Trane Service (beginning with Rev 29)				All		Reported if a compressor is found to be running without chilled water flow for three minutes. Previously, this error would be identified after five minutes.	
Software Error 1002: Call Trane Service (beginning with Rev 29)				All		Reported if state chart misalignment in stopped or inactive state occurs.	
Software Error 1003: Call Trane Service (beginning with Rev 29)				All		Reported if state chart misalignment in stopping state occurs.	
Software Error Number: 1001 (Rev 28)	All functions	Immediate	Latch - power down reset is reqd	All		A high level software watchdog has detected a condition in which there was a continuous 5 minute period of compressor operation, with neither chilled water flow nor a "contactor interrupt failure" diagnostic active. The occurrence of this software error message suggests an internal software state chart misalignment has occurred. The events that led up to this failure, if known, should be recorded and transmitted to Trane Controls Engineering - (SW rev 24 and higher)	
Starter Failed to Arm/Start - Cprsr 1A	Cprsr	Info	Latch	All		Starter failed to arm or start within the allotted time (15 seconds).	Local
Starter Failed to Arm/Start - Cprsr 1B	Cprsr	Info	Latch	All		Starter failed to arm or start within the allotted time (15 seconds).	Local
Starter Failed to Arm/Start - Cprsr 2A	Cprsr	Info	Latch	All		Starter failed to arm or start within the allotted time (15 seconds).	Local
Starter Failed to Arm/Start - Cprsr 2B	Cprsr	Info	Latch	All		Starter failed to arm or start within the allotted time (15 seconds).	Local
Starter Module Memory Error Type 1 - Starter 2A	None	Info	Latch	All		Checksum on RAM copy of the Starter LLID configuration failed. Configuration recalled from EEPROM.	Local
Starter Module Memory Error Type 1 - Starter 2B	None	Info	Latch	All		Checksum on RAM copy of the Starter LLID configuration failed. Configuration recalled from EEPROM.	Local
Starter Module Memory Error Type 1-Starter 1A	None	Info	Latch	All		Checksum on RAM copy of the Starter LLID configuration failed. Configuration recalled from EEPROM.	Local
Starter Module Memory Error Type 1-Starter 1B	None	Info	Latch	All		Checksum on RAM copy of the Starter LLID configuration failed. Configuration recalled from EEPROM.	Local
Starter Module Memory Error Type 2 - Starter 1A	Cprsr	Immediate	Latch	All		Checksum on EEPROM copy of the Starter LLID configuration failed. Factor default values used.	Local
Starter Module Memory Error Type 2 - Starter 1B	Cprsr	Immediate	Latch	All		Checksum on EEPROM copy of the Starter LLID configuration failed. Factor default values used.	Local
Starter Module Memory Error Type 2 - Starter 2A	Cprsr	Immediate	Latch	All		Checksum on EEPROM copy of the Starter LLID configuration failed. Factor default values used.	Local
Starter Module Memory Error Type 2 - Starter 2B	Cprsr	Immediate	Latch	All		Checksum on EEPROM copy of the Starter LLID configuration failed. Factor default values used.	Local
Starter Panel High Temperature Limit - Panel 1, Cprsr 1B	Cprsr 1B	Special Mode	NonLatch	All		Starter Panel High Limit Thermostat (170 F) trip was detected. Note: Other diagnostics that may occur as an expected consequence of the Panel High Temp Limit trip will be suppressed from annunciation. These include Phase Loss, Power Loss, and Transition Complete Input Open for Cprsr 1B	Local
Starter Panel High Temperature Limit - Panel 1, Cprsr 2A	Cprsr 2A	Special Mode	NonLatch	All		Starter Panel High Limit Thermostat (170 F) trip was detected. Note: Other diagnostics that may occur as an expected consequence of the Panel High Temp Limit trip will be suppressed from annunciation. These include Phase Loss, Power Loss, and Transition Complete Input Open for Cprsr 2A	Local



Diagnostics

Table 67. Main processor diagnostics (continued)

Diagnostic Name	Affects Target	Severity	Persist-ence	Active Modes		Criteria	Reset Level
				[Inactive Modes]			
Starter Panel High Temperature Limit - Panel 2, Cprsr 2B	Cprsr 2B	Special Mode	NonLatch	All		Starter Panel High Limit Thermostat (170 F) trip was detected. Note: Other diagnostics that may occur as an expected consequence of the Panel High Temp Limit trip will be suppressed from annunciation. These include Phase Loss, Power Loss, and Transition Complete Input Open for Cprsr 2B	Local
Suction Refrigerant Pressure Transducer - Circuit 1, Compressor 1A	Special	Immediate	Latch	All		Bad Sensor or LLID Circuit target if no isolation valves, Compressor target if isolation valves. Design Note: In the case of manifolded compressors w/o isolation valves, the occurrence of this diagnostic will also generate a comm loss with the nonexistent Suction Press Cprsr 1B in order to accomplish circuit shutdown.	Remote
Suction Refrigerant Pressure Transducer - Circuit 1, Compressor 1B	Cprsr 1B	Immediate	Latch	All		Bad Sensor or LLID. Design Note: For circuits with manifolded compressors w/o isolation valve option, this diagnostic will occur with the preceding diagnostic, even though this transducer is not required or installed.	Remote
Suction Refrigerant Pressure Transducer - Circuit 2, Compressor 2A	Special	Immediate	Latch	All		Bad Sensor or LLID Circuit target if no isolation valves, Compressor target if isolation valves. Design Note: In the case of manifolded compressors w/o isolation valves, the occurrence of this diagnostic will also generate a comm loss with the nonexistent Suction Press Cprsr 2B in order to accomplish circuit shutdown.	Remote
Suction Refrigerant Pressure Transducer - Circuit 2, Compressor 2B	Cprsr 2B	Immediate	Latch	All		Bad Sensor or LLID. Design Note: For circuits with manifolded compressors w/o isolation valve option, this diagnostic will occur with the preceding diagnostic, even though this transducer is not required or installed	Remote
Very Low Evaporator Refrigerant Pressure - Circuit 1	Chiller	Immediate	Latch	All [compressor or circuit in manual lockout]		The evaporator pressure dropped below 8 psia (or 5 psia in sftw prior to Oct '02) regardless of whether or not compressors are running on that circuit. This diagnostic was created to prevent compressor failures due to cross binding by forcing an entire chiller shutdown. If a given compressor or circuit is locked out, the suction pressure transducer(s) associated with it, will be excluded from causing this diagnostic.	Local
Very Low Evaporator Refrigerant Pressure - Circuit 2	Chiller	Immediate	Latch	All [compressor or circuit in manual lockout]		The evaporator pressure dropped below 8 psia (or 5 psia in sftw prior to Oct '02) regardless of whether or not compressors are running on that circuit. This diagnostic was created to prevent compressor failures due to cross binding by forcing an entire chiller shutdown. If a given compressor or circuit is locked out, the suction pressure transducer(s) associated with it, will be excluded from causing this diagnostic.	Local

Communication Diagnostics

The following communication loss diagnostics will not occur unless that input or output is required to be present by the particular configuration and installed options for the chiller.

Communication diagnostics (with the exception of "Excessive Loss of Comm" are named by the Functional Name of the input or output that is no longer being heard

from by the Main Processor. Many LLIDs, such as the Quad Relay LLID, have more than one functional output associated with it. A comm loss with such a multiple function board, will generate multiple diagnostics. Refer to the Chiller's wiring diagrams to relate the occurrence of multiple communication diagnostics back to the physical LLID boards that they have been assigned to (bound).

Table 68. Communication diagnostics

Diagnostic Name	Affects Target	Severity	Persist-ence	Active Modes		Criteria	Reset Level
				[Inactive Modes]			
Comm Loss: Chilled Water Flow Switch	Chiller	Immediate	Latch	All		Continual loss of communication between the MP and the Functional ID has occurred for a 30 second period.	Remote
Comm Loss: Cond Rfgr Pressure, Circuit #1	Circuit	Immediate	Latch	All		Continual loss of communication between the MP and the Functional ID has occurred for a 30 second period.	Remote
Comm Loss: Cond Rfgr Pressure, Circuit #2	Circuit	Immediate	Latch	All		Continual loss of communication between the MP and the Functional ID has occurred for a 30 second period.	Remote

Table 68. Communication diagnostics (continued)

Diagnostic Name	Affects Target	Severity	Persistence	Active Modes [Inactive Modes]	Criteria	Reset Level
Comm Loss: Electronic Expansion Valve, Circuit #1	Circuit	Normal	Latch	All	Continual loss of communication between the MP and the Functional ID has occurred for a 30 second period.	Remote
Comm Loss: Electronic Expansion Valve, Circuit #2	Circuit	Normal	Latch	All	Continual loss of communication between the MP and the Functional ID has occurred for a 30 second period.	Remote
Comm Loss: Emergency Stop	Chiller	Normal	Latch	All	Continual loss of communication between the MP and the Functional ID has occurred for a 30 second period.	Remote
Comm Loss: Evap Oil Return Valve, Cprsr 1A	Cprsr	Normal	Latch	All	Continual loss of communication between the MP and the Functional ID has occurred for a 30 second period.	Remote
Comm Loss: Evap Oil Return Valve, Cprsr 1B	Cprsr	Normal	Latch	All	Continual loss of communication between the MP and the Functional ID has occurred for a 30 second period.	Remote
Comm Loss: Evap Oil Return Valve, Cprsr 2A	Cprsr	Normal	Latch	All	Continual loss of communication between the MP and the Functional ID has occurred for a 30 second period.	Remote
Comm Loss: Evap Oil Return Valve, Cprsr 2B	Cprsr	Normal	Latch	All	Continual loss of communication between the MP and the Functional ID has occurred for a 30 second period.	Remote
Comm Loss: Evaporator Entering Water Temperature	Chilled Water Reset	Special Mode	Latch	All	Continual loss of communication between the MP and the Functional ID has occurred for a 30 second period. Chiller shall remove any Return or Constant Return Chilled Water Reset, if it was in effect. Apply slew rates per Chilled Water Reset spec.	Remote
Comm Loss: Evaporator Leaving Water Temperature	Chiller	Normal	Latch	All	Continual loss of communication between the MP and the Functional ID has occurred for a 30 second period.	Remote
Comm Loss: Evaporator Rfgt Drain Valve - Ckt 1	Circuit	Normal	Latch	All	Continual loss of communication between the MP and the Functional ID has occurred for a 30 second period.	Remote
Comm Loss: Evaporator Rfgt Drain Valve - Ckt 2	Circuit	Normal	Latch	All	Continual loss of communication between the MP and the Functional ID has occurred for a 30 second period.	Remote
Comm Loss: Evaporator Rfgt Liquid Level, Circuit #1	Circuit	Immediate	Latch	All	Continual loss of communication between the MP and the Functional ID has occurred for a 30 second period.	Remote
Comm Loss: Evaporator Rfgt Liquid Level, Circuit #2	Circuit	Immediate	Latch	All	Continual loss of communication between the MP and the Functional ID has occurred for a 30 second period.	Remote
Comm Loss: Evaporator Rfgt Pressure, Circuit #1	Circuit	Immediate	Latch	All [Ckt/Cprsr lock out]	Continual loss of communication between the MP and the Functional ID has occurred for a 30 second period. Note: This diagnostic is replaced by diagnostic 5FB below with Rev 15.0	Remote
Comm Loss: Evaporator Rfgt Pressure, Circuit #2	Circuit	Immediate	Latch	All [Ckt/Cprsr lock out]	Continual loss of communication between the MP and the Functional ID has occurred for a 30 second period. Note: This diagnostic is replaced by diagnostic 5FD below with Rev 15.0	Remote
Comm Loss: Evaporator Water Pump Control	Chiller	Normal	Latch	All	Continual loss of communication between the MP and the Functional ID has occurred for a 30 second period.	Remote
Comm Loss: External Auto/Stop	Chiller	Normal	Latch	All	Continual loss of communication between the MP and the Functional ID has occurred for a 30 second period.	Remote
Comm Loss: External Chilled Water Setpoint	External Chilled Water Setpoint	Special Mode	NonLatch	All	Continual loss of communication between the MP and the Functional ID has occurred for a 30 second period. Chiller shall discontinue use of the External Chilled Water Setpoint source and revert to the next higher priority for setpoint arbitration	Remote
Comm Loss: External Circuit Lockout, Circuit #1	Circuit	Special Mode	Latch	All	Continual loss of communication between the MP and the Functional ID has occurred for a 30 second period. MP will nonvolatily hold the lockout state (enabled or disabled) that was in effect at the time of comm loss.	Remote
Comm Loss: External Circuit Lockout, Circuit #2	Circuit	Special Mode	Latch	All	Continual loss of communication between the MP and the Functional ID has occurred for a 30 second period. MP will nonvolatily hold the lockout state (enabled or disabled) that was in effect at the time of comm loss	Remote
Comm Loss: External Current Limit Setpoint	External Current Limit setpoint	Special Mode	NonLatch	All	Continual loss of communication between the MP and the Functional ID has occurred for a 30 second period. Chiller shall discontinue use of the External Current limit setpoint and revert to the next higher priority for Current Limit setpoint arbitration	Remote



Diagnostics

Table 68. Communication diagnostics (continued)

Diagnostic Name	Affects Target	Severity	Persist-ence	Active Modes [Inactive Modes]	Criteria	Reset Level
Comm Loss: Fan Control Circuit #1, Stage #1	Circuit	Normal	Latch	All	Continual loss of communication between the MP and the Functional ID has occurred for a 30 second period.	Remote
Comm Loss: Fan Control Circuit #1, Stage #2	Circuit	Normal	Latch	All	Continual loss of communication between the MP and the Functional ID has occurred for a 30 second period.	Remote
Comm Loss: Fan Control Circuit #1, Stage #3	Circuit	Normal	Latch	All	Continual loss of communication between the MP and the Functional ID has occurred for a 30 second period.	Remote
Comm Loss: Fan Control Circuit #1, Stage #4	Circuit	Normal	Latch	All	Continual loss of communication between the MP and the Functional ID has occurred for a 30 second period.	Remote
Comm Loss: Fan Control Circuit #2, Stage #1	Circuit	Normal	Latch	All	Continual loss of communication between the MP and the Functional ID has occurred for a 30 second period.	Remote
Comm Loss: Fan Control Circuit #2, Stage #2	Circuit	Normal	Latch	All	Continual loss of communication between the MP and the Functional ID has occurred for a 30 second period.	Remote
Comm Loss: Fan Control Circuit #2, Stage #3	Circuit	Normal	Latch	All	Continual loss of communication between the MP and the Functional ID has occurred for a 30 second period.	Remote
Comm Loss: Fan Control Circuit #2, Stage #4	Circuit	Normal	Latch	All	Continual loss of communication between the MP and the Functional ID has occurred for a 30 second period.	Remote
Comm Loss: Fan Inverter Fault, Circuit #1 or Circuit #1, Drive 1	Inverter	Special Mode	Latch	All	Continual loss of communication between the MP and the Functional ID has occurred for a 30 second period. Operate the remaining fans as fixed speed fan deck.	Remote
Comm Loss: Fan Inverter Fault, Circuit #1, Drive 2	Inverter	Special Mode	Latch	All	Continual loss of communication between the MP and the Functional ID has occurred for a 30 second period. Operate the remaining fans as fixed speed fan deck.	Remote
Comm Loss: Fan Inverter Fault, Circuit #2 or Circuit #2, Drive 1	Inverter	Special Mode	Latch	All	Continual loss of communication between the MP and the Functional ID has occurred for a 30 second period. Operate the remaining fans as fixed speed fan deck.	Remote
Comm Loss: Fan Inverter Fault, Circuit #2, Drive 2	Inverter	Special Mode	Latch	All	Continual loss of communication between the MP and the Functional ID has occurred for a 30 second period. Operate the remaining fans as fixed speed fan deck.	Remote
Comm Loss: Fan Inverter Power, Circuit #1 or Circuit #1 Drive 1 and 2	Circuit	Normal	Latch	All	Continual loss of communication between the MP and the Functional ID has occurred for a 30 second period.	Remote
Comm Loss: Fan Inverter Power, Circuit #2 or Circuit #2 Drive 1 and 2	Circuit	Normal	Latch	All	Continual loss of communication between the MP and the Functional ID has occurred for a 30 second period.	Remote
Comm Loss: Fan Inverter Speed Command, Circuit #1 or Circuit #1 Drive 1 and 2	Inverter	Special Mode	Latch	All	Continual loss of communication between the MP and the Functional ID has occurred for a 30 second period. Operate the remaining fans as fixed speed fan deck.	Remote
Comm Loss: Fan Inverter Speed Command, Circuit #2 or Circuit #2 Drive 1 and 2	Inverter	Special Mode	Latch	All	Continual loss of communication between the MP and the Functional ID has occurred for a 30 second period. Operate the remaining fans as fixed speed fan deck.	Remote
Comm Loss: Female Step Load Compressor 1A	Cprsr	Normal	Latch	All	Continual loss of communication between the MP and the Functional ID has occurred for a 30 second period.	Remote
Comm Loss: Female Step Load Compressor 1B	Cprsr	Normal	Latch	All	Continual loss of communication between the MP and the Functional ID has occurred for a 30 second period.	Remote
Comm Loss: Female Step Load Compressor 2A	Cprsr	Normal	Latch	All	Continual loss of communication between the MP and the Functional ID has occurred for a 30 second period.	Remote
Comm Loss: Female Step Load Compressor 2B	Cprsr	Normal	Latch	All	Continual loss of communication between the MP and the Functional ID has occurred for a 30 second period.	Remote
Comm Loss: High Pressure Cutout Switch, Cprsr 1A	Cprsr	Immediate	Latch	All	Continual loss of communication between the MP and the Functional ID has occurred for a 30 second period.	Remote
Comm Loss: High Pressure Cutout Switch, Cprsr 1B	Cprsr	Immediate	Latch	All	Continual loss of communication between the MP and the Functional ID has occurred for a 30 second period.	Remote

Table 68. Communication diagnostics (continued)

Diagnostic Name	Affects Target	Severity	Persist-ence	Active Modes [Inactive Modes]	Criteria	Reset Level
Comm Loss: High Pressure Cutout Switch, Cprsr 2A	Cprsr	Immediate	Latch	All	Continual loss of communication between the MP and the Functional ID has occurred for a 30 second period.	Remote
Comm Loss: High Pressure Cutout Switch, Cprsr 2B	Cprsr	Immediate	Latch	All	Continual loss of communication between the MP and the Functional ID has occurred for a 30 second period.	Remote
Comm Loss: Ice-Machine Control	Ice Making Mode	Special Mode	Latch	All	Continual loss of communication between the MP and the Functional ID has occurred for a 30 second period. Chiller shall revert to normal (non-ice building) mode regardless of last state.	Remote
Comm Loss: Ice-Making Status	Ice-Machine	Special Mode	Latch	All	Continual loss of communication between the MP and the Functional ID has occurred for a 30 second period. Chiller shall revert to normal (non-ice building) mode regardless of last state.	Remote
Comm Loss: Intermediate Oil Pressure, Cprsr 1A	Cprsr	Immediate	Latch	All	Continual loss of communication between the MP and the Functional ID has occurred for a 30 second period.	Remote
Comm Loss: Intermediate Oil Pressure, Cprsr 1B	Cprsr	Immediate	Latch	All	Continual loss of communication between the MP and the Functional ID has occurred for a 30 second period.	Remote
Comm Loss: Intermediate Oil Pressure, Cprsr 2A	Cprsr	Immediate	Latch	All	Continual loss of communication between the MP and the Functional ID has occurred for a 30 second period.	Remote
Comm Loss: Intermediate Oil Pressure, Cprsr 2B	Cprsr	Immediate	Latch	All	Continual loss of communication between the MP and the Functional ID has occurred for a 30 second period.	Remote
Comm Loss: Local BAS Interface	None	Special Mode	Latch	All	Continual loss of communication between the MP and the Functional ID has occurred for a 30 second period.	Remote
Comm Loss: Male Port Load Compressor 1A	Cprsr	Normal	Latch	All	Continual loss of communication between the MP and the Functional ID has occurred for a 30 second period.	Remote
Comm Loss: Male Port Load Compressor 1B	Cprsr	Normal	Latch	All	Continual loss of communication between the MP and the Functional ID has occurred for a 30 second period.	Remote
Comm Loss: Male Port Load Compressor 2A	Cprsr	Normal	Latch	All	Continual loss of communication between the MP and the Functional ID has occurred for a 30 second period.	Remote
Comm Loss: Male Port Load Compressor 2B	Cprsr	Normal	Latch	All	Continual loss of communication between the MP and the Functional ID has occurred for a 30 second period.	Remote
Comm Loss: Male Port Unload Compressor 1A	Cprsr	Normal	Latch	All	Continual loss of communication between the MP and the Functional ID has occurred for a 30 second period.	Remote
Comm Loss: Male Port Unload Compressor 1B	Cprsr	Normal	Latch	All	Continual loss of communication between the MP and the Functional ID has occurred for a 30 second period.	Remote
Comm Loss: Male Port Unload Compressor 2A	Cprsr	Normal	Latch	All	Continual loss of communication between the MP and the Functional ID has occurred for a 30 second period.	Remote
Comm Loss: Male Port Unload Compressor 2B	Cprsr	Normal	Latch	All	Continual loss of communication between the MP and the Functional ID has occurred for a 30 second period.	Remote
Comm Loss: Oil Temperature, Circuit #1 or Cprsr 1A	Cprsr	Normal	Latch	All	Continual loss of communication between the MP and the Functional ID has occurred for a 30 second period.	Remote
Comm Loss: Oil Temperature, Circuit #2 or Cprsr 2A	Cprsr	Normal	Latch	All	Continual loss of communication between the MP and the Functional ID has occurred for a 30 second period.	Remote
Comm Loss: Oil Temperature, Cprsr 1B	Cprsr	Normal	Latch	All	Continual loss of communication between the MP and the Functional ID has occurred for a 30 second period.	Remote
Comm Loss: Oil Temperature, Cprsr 2B	Cprsr	Normal	Latch	All	Continual loss of communication between the MP and the Functional ID has occurred for a 30 second period.	Remote
Comm Loss: Outdoor Air Temperature	Chiller	Normal	Latch	All	Continual loss of communication between the MP and the Functional ID has occurred for a 30 second period. Note that if this diagnostic occurs, operational pumpdown will be performed regardless of the last valid temperature	Remote
Comm Loss: Starter 1A	Cprsr	Immediate	Latch	All	Continual loss of communication between the MP and the Functional ID has occurred for a 30 second period.	Local



Diagnostics

Table 68. Communication diagnostics (continued)

Diagnostic Name	Affects Target	Severity	Persist-ence	Active Modes [Inactive Modes]	Criteria	Reset Level
Comm Loss: Starter 1B	Cprsr	Immediate	Latch	All	Continual loss of communication between the MP and the Functional ID has occurred for a 30 second period.	Local
Comm Loss: Starter 2A	Cprsr	Immediate	Latch	All	Continual loss of communication between the MP and the Functional ID has occurred for a 30 second period.	Local
Comm Loss: Starter 2B	Cprsr	Immediate	Latch	All	Continual loss of communication between the MP and the Functional ID has occurred for a 30 second period.	Local
Comm Loss: Starter Panel High Temperature Limit - Panel 1, Cprsr 2A	None	Info	Latch	All	Continual loss of communication between the MP and the Functional ID has occurred for a 30 second period.	Local
Comm Loss: Starter Panel High Temperature Limit - Panel 1, Cprsr 1B	None	Info	Latch	All	Continual loss of communication between the MP and the Functional ID has occurred for a 30 second period.	Local
Comm Loss: Starter Panel High Temperature Limit - Panel 2, Cprsr 2B	None	Info	Latch	All	Continual loss of communication between the MP and the Functional ID has occurred for a 30 second period.	Local
Comm Loss: Status/Annunciation Relays	None	Info	Latch	All	Continual loss of communication between the MP and the Functional ID has occurred for a 30 second period.	Remote
Comm Loss: Suction Pressure Cprsr 1A	Special	Immediate	Latch	All	Continual loss of communication between the MP and the Functional ID has occurred for a 30 second period. Circuit target if no isolation valves, Compressor target if isolation valves or simplex. Design Note: In the case of manifolded compressors w/ no isolation valves, the occurrence of this diagnostic will also generate a comm loss with the nonexistent Suction Press Cprsr 1B in order to accomplish circuit shutdown.	Remote
Comm Loss: Suction Pressure Cprsr 1B	Cprsr	Immediate	Latch	All	Continual loss of communication between the MP and the Functional ID has occurred for a 30 second period. Design Note: For circuits with manifolded compressors w/o isolation valve option, this diagnostic will occur with the preceding diagnostic, even though this transducer is not required or installed.	Remote
Comm Loss: Suction Pressure Cprsr 2A	Special	Immediate	Latch	All	Continual loss of communication between the MP and the Functional ID has occurred for a 30 second period. Circuit target if no isolation valves, Compressor target if isolation valves or simplex. Design Note: In the case of manifolded compressors w/ no isolation valves, the occurrence of this diagnostic will also generate a comm loss with the nonexistent Suction Press Cprsr 2B in order to accomplish circuit shutdown.	Remote
Comm Loss: Suction Pressure Cprsr 2B	Cprsr	Immediate	Latch	All	Continual loss of communication between the MP and the Functional ID has occurred for a 30 second period. Design Note: For circuits with manifolded compressors w/o isolation valve option, this diagnostic will occur with the preceding diagnostic, even though this transducer is not required or installed.	Remote
Excessive Loss of Comm	Chiller	Immediate	Latch	All	Loss of comm with 75% or more (Rev 18 and earlier 10%) of the llds configured for the system has been detected. This diagnostic will suppress the callout of all subsequent comm loss diagnostics. Check power supply(s) and power disconnects - troubleshoot LLIDS buss using TechView	Remote
Starter 1A Comm Loss: MP	Cprsr	Immediate	Latch	All	Starter has had a loss of communication with MP for a 15 second period.	Local
Starter 1B Comm Loss: MP	Cprsr	Immediate	Latch	All	Starter has had a loss of communication with MP for a 15 second period.	Local
Starter 2A Comm Loss: MP	Cprsr	Immediate	Latch	All	Starter has had a loss of communication with MP for a 15 second period.	Local
Starter 2B Comm Loss: MP	Cprsr	Immediate	Latch	All	Starter has had a loss of communication with MP for a 15 second period.	Local

Main Processor Boot Messages and Diagnostics

Table 69. Main processor boot messages and diagnostics

DynaView Display Message	Description Troubleshooting
A Valid Configuration is Present	A valid configuration is present in the MP's nonvolatile memory. The configuration is a set of variables and settings that define the physical makeup of this particular chiller. These include: number/airflow,/and type of fans, number/and size of compressors, special features, characteristics, and control options. // Temporary display of this screen is part of the normal power up sequence.
App Present. Running Selftest... Selftest Passed	An application has been detected in the Main Processor's nonvolatile memory and the boot code is proceeding to run a check on its entirety. 8 seconds later, the boot code had completed and passed the (CRC) test. // Temporary display of this screen is part of the normal power up sequence.
App Present. Running Selftest... Err3: CRC Failure	An application has been detected in Main Processor's nonvolatile memory and the boot code is proceeding to run a check on its entirety. A few seconds later, the boot code had completed but failed the (CRC) test. //Connect a TechView Service Tool to the MP's serial port, provide chiller model number (configuration information) and download the configuration if prompted by TechView. Then proceed to download the most recent RTAC application or specific version as recommended by Technical Service. Note that this error display may also occur during the programming process, if the MP never had a valid application any time prior to the download. If the problem persists, replace the MP.
Boot Software Part Numbers: LS Flash --> 6200-0318-04 MS Flash --> 6200-0319-04	The "boot code" is the portion of the code that is resident in all MPs regardless of what application code (if any) is loaded. Its main function is to run power up tests and provide a means for downloading application code via the MP's serial connection. The Part numbers for the code are displayed in the lower left hand corner of the DynaView during the early portion of the power up sequence and during special programming and converter modes. See below. For the EasyView, the extension of the boot code part number is displayed for approximately 3 immediately following power up. // This is normal, but you should provide this information when contacting Technical Service about power up problems.
Converter Mode	A command was received from the Service Tool (Tech View) to stop the running application and run in the "converter mode". In this mode the MP acts as a simple gateway and allows the TechView service computer to talk to all the LLIDS on the IPC3 bus.
Err2: RAM Addr Test #1 Failure	There were RAM errors detected in RAM Address Test #1. // Recycle power, if error persists, replace MP.
Err2: RAM Addr Test #2 Failure	There were RAM errors detected in RAM Address Test #2. //Recycle power, if the error persists, replace MP.
Err2: RAM Pattern 1 Failure	There were RAM errors detected in RAM Test Pattern #1. // Recycle power, if the error persists, replace MP.
Err2: RAM Pattern 2 Failure	There were RAM errors detected in RAM Test Pattern #2. //Recycle power, if the error persists, replace MP.
Err4: UnHandled Interrupt Restart Timer: [3 sec countdown timer]	An unhandled interrupt has occurred while running the application code. This event will normally cause a safe shutdown of the entire chiller. Once the countdown timer reaches 0, the processor will reset, clear diagnostics, and attempt to restart the application and allow a normal restart of chiller as appropriate. // This condition might occur due to a severe electro-magnetic transient such as can be caused by a near lightning strike. Such events should be rare or isolated and if no damage results to the CH.530 control system, the Chiller will experience a shutdown and restart. If this occurs more persistently it may be due to an MP hardware problem. Try replacing the MP. If replacement of the MP proves ineffective, the problem may be a result of extremely high radiated or conducted EMI. Contact Technical Service. If this screen occurs immediately after a software download, attempt to reload both the configuration and the application. Failing this, contact Technical Service.
Err5: Operating System Error Restart Timer: [30 sec countdown timer]	An Operating System error has occurred while running the application code. This event will normally cause a safe shutdown of the entire chiller. Once the countdown timer reaches 0, the processor will reset, clear diagnostics, and attempt to restart the application and allow a normal restart of chiller as appropriate. // See Err 4 above
Err6: Watch Dog Timer Error Restart Timer: [30 sec countdown timer]	A Watch Dog Timer Error has occurred while running the application code. This event will normally cause a safe shutdown of the entire chiller. Once the countdown timer reaches 0, the processor will reset, clear diagnostics, and attempt to restart the application allowing a normal restart of chiller as appropriate.
Err7: Unknown Error Restart Timer: [30 sec countdown timer]	An unknown Error has occurred while running the application code. This event will normally cause a safe shutdown of the entire chiller. Once the countdown timer reaches 0, the processor will reset, clear diagnostics, and attempt to restart the application allowing a normal restart of chiller as appropriate
Err8: Held in Boot by User Key Press	The boot detected a key press in the center of the DynaView or both the + and - keys pressed on an EasyView while the MP was in the boot code. Upon seeing this message the user can use Techview to connect to the MP to perform a software download or another service tool function.
No Application Present Please Load Application...	No Main Processor Application is present - There are no RAM Test Errors. // Connect a TechView Service Tool to the MP's serial port, provide chiller model number (configuration information) and download the configuration if prompted by TechView. Then proceed to download the most recent RTAC application or specific version as recommended by Technical Service.
Programming Mode	A command was received by the MP from the Tech View Service Tool and the MP is in the process of first erasing and then writing the program code to its internal Flash (nonvolatile) Memory. Note that if the MP never had a prior application already in memory, the error code "Err3"will be displayed instead of this, during the programming download process.



Unit Wiring

Table 70 provides a list of field wiring diagrams, electrical schematics and connection diagrams for 120-500 ton RTAC units. The complete unit wiring package is documented in RTAC-SVE01*-EN. A laminated wiring diagram kit is also shipped with each RTAC unit.

Table 70. RTAC unit wiring drawing numbers

Drawing Number	Description
2309-2097	Schematic - 2 Compressor Units
Sheet 1	Table of Contents & Notes
Sheet 2	Legend
Sheet 3 (X-Line)	Compressor 1A (X-Line)
Sheet 3 (Y-Delta)	Compressor 1A (Y-delta)
Sheet 4 (X-Line)	Compressor 2A (X-Line)
Sheet 4 (Y-Delta)	Compressor 2A (Y-delta)
Sheet 5	Fans, Std & Prem, Medium Air Cooled
Sheet 6	Fans, 140 & 155 Std, 120 & 130 Prem 50 Hz
Sheet 7	Fans 225, 250 Prem 60 Hz, 185 & 200 Extra 60 Hz
Sheet 8	VSD Fans - Circuits 1 & 2
Sheet 9	Controls
Sheet 10	LLID Bus
Sheet 11	Remote Evaporator
2309-4621	Schematic - 3 Compressor Units, X-Line
Sheet 1	Table of Contents & Notes
Sheet 2	Devices, Descriptions & Designations
Sheet 3	Compressor Power 1A & Fan Control Ckt 1
Sheet 4	Compressor Power 1B
Sheet 5	Compressor Power 2A & Fan Control Ckt 2
Sheet 6	Fan Power Circuit 1
Sheet 7	Fan Power Circuit 2
Sheet 8	Common Control - Panel LLIDs
Sheet 9	Common Control - Panel LLIDs
Sheet 10	Common Control - Panel LLIDs
2309-4622	Schematic - 3 Compressor, Units Y-Delta
Sheet 1	Table of Contents & Notes
Sheet 2	Devices, Descriptions & Designations
Sheet 3	Compressor Power 1A & Fan Control Ckt 1
Sheet 4	Compressor Power 1B
Sheet 5	Compressor Power 2A & Fan Control Ckt 2
Sheet 6	Fan Power Circuit 1
Sheet 7	Fan Power Circuit 2
Sheet 8	Common Control - Panel LLIDs
Sheet 9	Common Control - Panel LLIDs
Sheet 10	Common Control - Panel LLIDs

Table 70. RTAC unit wiring drawing numbers

Drawing Number	Description	
2309-4623	Sheet 1	Table of Contents & Notes
	Sheet 2	Devices, Descriptions & Designations
	Sheet 3	Compressor Power 1A & Fan Control Ckt 1
	Sheet 4	Compressor Power 1B
	Sheet 5	Compressor Power 2A & Fan Control Ckt 2
	Sheet 6	Compressor Power 2B
	Sheet 7	Fan Power Circuit 1
	Sheet 8	Fan Power Circuit 2
	Sheet 9	Common Control - Panel LLIDs
	Sheet 10	Common Control - Panel LLIDs
	Sheet 11	Common Control - Panel LLIDs
2309-4624	Sheet 1	Table of Contents & Notes
	Sheet 2	Devices, Descriptions & Designations
	Sheet 3	Compressor Power 1A & Fan Control Ckt 1
	Sheet 4	Compressor Power 1B
	Sheet 5	Compressor Power 2A & Fan Control Ckt 2
	Sheet 6	Compressor Power 2B
	Sheet 7	Fan Power Circuit 1
	Sheet 8	Fan Power Circuit 2
	Sheet 9	Common Control - Panel LLIDs
	Sheet 10	Common Control - Panel LLIDs
	Sheet 11	Common Control - Panel LLIDs
2309-4871	Component Location	2 Compressor Units
2309-4874	Component Location	3 Compressor Units
2309-4873	Component Location	4 Compressor Units
2309-4872	Component Location	2 Compressor - Optional Remote Evaporator
2309-2248	Field Layout	2 Compressor Units
2309-2239	Field Layout	3 or 4 Compressor Units
2309-2208	Field Wiring; RTAC, 2 Compressor Units	2 Compressor Units
2309-2223	Field Wiring	3 or 4 Compressor Units, Single Source Power
2309-2222	Field Wiring	3 or 4 Compressor Units, Dual Source Power
2309-7572	Sequence of Operation	2 Compressor Units
2309-7581	Sequence of Operation	3 or 4 Compressor Units



Log and Check Sheet

The operator log and check sheet are included for use as appropriate, for installation completion verification before Trane start-up is scheduled, and for reference during the Trane start-up.

Where the log or check sheet also exists outside of this publication as standalone literature, the literature order number is also listed.

- RTAC Series R Air-Cooled Chiller Installation Completion Check Sheet and Request for Trane Service (RLC-ADF003*-EN)
- Operator Log
- Start-Up Test Log



RTAC Series R[®] Air-Cooled Chiller Installation Completion Check Sheet and Request for Trane Service

Important: A copy of this completed form must be submitted to the Trane service agency that will be responsible for the start-up of the chiller. Start-up will NOT proceed unless applicable items listed in this form have been satisfactorily completed.

To:	Trane Service Office:
S.O. Number:	Serial Numbers:
Job/Project Name:	
Address:	
The following items are being installed and will be completed by:	

Important: Start-up must be performed by Trane or an agent of Trane specifically authorized to perform start-up of Trane[®] products. Contractor shall provide Trane (or an agent of Trane specifically authorized to perform start-up) with notice of the scheduled start-up at least two weeks prior to the scheduled start-up.

Check boxes if the task is complete or if the answer is "yes."

1. Screw Chiller

- Installation meets foundation requirements.
- Verify service clearances meet requirements.
- In place and piped.
- Isolation pads or neoprene pads installed (optional).

2. Piping

Chilled water piping connected to:

- Evaporator
- Air handling units
- Pumps
- Flow switch or flow proving device installed
- Required strainer installed in entering evaporator water piping and cleaned
- Water supply connected to filling system (expansion tank)
- Systems filled
- Pumps run, air bled from system
- Relief valve ventilation piping installed (if applicable)
- Flow balancing valves installed in leaving chilled water
- Gauges, thermometers and air vents installed on both sides of evaporator

3. Wiring

- Wire size per submittal, NEC and applicable local electrical codes. Verify only copper conductors used.
- Full power available, and within utilization range.
- Interconnecting wiring to remote evaporator (if applicable)
- External interlocks (flow switch, pumps auxiliary, etc.)
- Chilled water pump (connected and tested)
- 115 Vac power available for service tools (recommended)
- All controls installed and connected

4. Testing

- Dry nitrogen available for pressure testing (if required)
- Trace gas amounts of R-134a available for leak testing (if required)

5. Refrigerant on job site (if required)

6. Systems can be operated under load conditions

7. Owner awareness

- If it is required by local code, is a self-contained breathing apparatus available?
- Has the owner been fully instructed on the proper use of refrigerant?
- Does the owner have a copy of the MSDS for refrigerant?
- Was the owner given a copy of the Refrigerant Handling Guidelines?

Note: Additional time required to properly complete the start-up and commissioning, due to any incompleteness of the installation, will be invoiced at prevailing rates.

This is to certify that the Trane® equipment has been properly and completely installed, and that the applicable items listed above have been satisfactorily completed.

Important: It is required that the chiller heaters are energized for a minimum of 24 hours prior to start up. Therefore, the chiller should have power for this amount of time before Trane Service arrives to do start-up of the equipment.

Checklist completed by: _____

Signed: _____ Date: _____

In accordance with your quotation and our purchase order number _____, we will therefore require the presence of Trane service on this site, for the purpose of start-up and commissioning, by _____ (date).

Note: Minimum two-week advance notification is required to allow scheduling of the chiller start-up.

Additional comments/instructions: _____

Note: A copy of this completed form must be submitted to the Trane Service Office that will be responsible for start-up of chiller.

Trane and the Trane logo are trademarks or registered trademarks of Trane in the United States and other countries.



Trane optimizes the performance of homes and buildings around the world. A business of Ingersoll Rand, the leader in creating and sustaining safe, comfortable and energy efficient environments, Trane offers a broad portfolio of advanced controls and HVAC systems, comprehensive building services, and parts. For more information, visit www.Trane.com.

Trane has a policy of continuous product and product data improvement and reserves the right to change design and specifications without notice.





Operator Log

RTAC CHILLER LOG						
Job Name			Job Location			
Model #			Serial #			
Status View: *						
Chiller Tab:	15 min	30 min	45 min	15 min	30 min	45 min
Operating Mode						
Outdoor Air Temperature	F or C					
Active Chill Water Setpoint	F or C					
Active Current Limit Setpoint						
Evaporator Entering Water Temp.	F or C					
Evaporator Leaving Water Temp.	F or C					
	Circuit 1 Tab			Circuit 2 Tab		
External Hardwired Lockout	Not Locked out/ Locked out			Not Locked out/ Locked out		
Front Panel Lockout	Not Locked out/ Locked out			Not Locked out/ Locked out		
	15 min	30 min	45 min	15 min	30 min	45 min
AirFlow	%					
Inverter Speed	%					
Condenser Refrigerant Pressure	psig/kPa					
Saturated Condenser Rfgt. Temp.	F or C					
Differential Refrigerant Pressure	psid/kPA					
Evaporator Refrigerant Pressure	psig/kPa					
Saturated Evaporator Rfgt.Temp.	F or C					
EXV Position	%					
Evaporator Rfgt Liquid Level	in/mm					
	Compressor 1A Tab			Compressor 1B Tab		
Operating Mode						
Hours	Hrs/mins			Hrs/mins		
Starts						
	15 min	30 min	45 min	15 min	30 min	45 min
Phase A - B Voltage	volts					
Average Line Current	%RLA					
Line 1 current	amps					
Line 2 current	amps					
Line 3 current	amps					
Line 1 current	%RLA					
Line 2 current	%RLA					
Line 3 current	%RLA					
Evaporator Oil Return Solenoid	open/closed	open/closed	open/closed	open/closed	open/closed	open/closed
Supply Oil Temperature	F or C					
Intermediate Oil Pressure	psig/kPa					
Female Step solenoid	load/unload	load/unload	load/unload	load/unload	load/unload	load/unload
High Pressure Cutout switch	good/tripped	good/tripped	good/tripped	good/tripped	good/tripped	good/tripped
Comments:						



RTAC CHILLER LOG

		Compressor 2A Tab			Compressor 2B Tab		
Operating Mode							
Hours		Hrs/mins			Hrs/mins		
Starts							
		15 min	30 min	45 min	15 min	30 min	45 min
Phase A - B Voltage	volts						
Average Line Current	%RLA						
Line 1 current	amps						
Line 2 current	amps						
Line 3 current	amps						
Line 1 current	%RLA						
Line 2 current	%RLA						
Line 3 current	%RLA						
Evaporator Oil Return Solenoid		open/closed	open/closed	open/closed	open/closed	open/closed	open/closed
Supply Oil Temperature	F or C						
Intermediate Oil Pressure	psig/kPa						
Female Step solenoid		load/unload	load/unload	load/unload	load/unload	load/unload	load/unload
High Pressure Cutout switch		good/tripped	good/tripped	good/tripped	good/tripped	good/tripped	good/tripped
Comments:							



RTAC Start-Up Test Log

RTAC START-UP TEST LOG			
Model #			
Job Name		Job Location	
CRC #		Serial #	
Sales Order #	Ship Date	Job Elevation (ft. above sea level)	
Starter Data:		Start-up Only	
Manufacturer		Chiller Appearance on arrival:	
Type: (wye-delta or x-line)		Machine gauge pressure:	ckt1/ckt2
Vendor ID #/ Model #:		Machine CH.530 pressure	ckt1/ckt2
Volts	Amps	Hz	Unit R-134a Charge
			lbs
Compressor Data:		Unit oil charge (OIL00048)	gal
Compressor A:		Pressure Test (if required)	
	Model #:	Vacuum after leak test=	mm
	Serial #	Standing Vacuum test=	mm rise in hrs
	RLA	Current Transformers	
	KW	Part number ("X" code and 2-digit extension)	
	Volts	X	
	HZ	X	
Compressor B:		X	
	Model #:	X	
	Serial #	X	
	RLA	X	
	KW	Summary of Options Installed	
	Volts	Y N	Tracer Communications Interface
	HZ	Y N	Ice Making
Compressor C:		Y N Other	
	Model #:	Y N Other	
	Serial #	Y N Other	
	RLA	Evap Design Conditions	
	KW	GPM	PSID
	Volts	Entering Water:	Leaving Water:
	HZ	% Glycol:	
Compressor D:		Type of Glycol:	
	Model #:	Evap Actual Conditions	
	Serial #	GPM	PSID
	RLA	Entering Water:	Leaving Water:
	KW	% Glycol:	
	Volts	Type of Glycol:	
	HZ		
Owner Witness Signature:			



Trane optimizes the performance of homes and buildings around the world. A business of Ingersoll Rand, the leader in creating and sustaining safe, comfortable and energy efficient environments, Trane offers a broad portfolio of advanced controls and HVAC systems, comprehensive building services, and parts. For more information, visit www.Trane.com.

Trane has a policy of continuous product and product data improvement and reserves the right to change design and specifications without notice.