



Product Catalog

Optimus™ Water-Cooled Chillers Model RTHD

150 to 430 (60 Hz) Nominal Tons

125 to 430 (50 Hz) Nominal Tons





Introduction

To meet a wide range of applications in the medium-tonnage, water-cooled market, Trane is proud to recommend the model RTHD helical-rotary liquid chiller. This chiller provides application versatility, ease of installation, control precision, reliability, energy efficiency, and operational cost-effectiveness. The RTHD chiller is designed to deliver proven performance, plus all the benefits of an advanced heat transfer design and a low speed, direct-drive compressor.

Important Features

- High full-load energy efficiency reduces both operating and life-cycle costs.
- Tracer® UC800 controls enable:
 - scrolling access to inputs and operating information via the LCD touch-screen display
 - freedom from interoperability concerns with LonMark® and BACnet® communications
 - job-specific communication options that allow greater reporting flexibility
- Improved startup temperature capabilities and reduced sensitivity to condenser water temperatures alleviate the most common startup concerns.

The industrial-grade design of the helical-rotary chiller is ideal for both industrial and commercial markets, in applications such as office buildings, hospitals, schools, retail buildings, and industrial facilities. The linear unloading compressor, wide operating temperature range, advanced controls, electronic expansion valve, short anti-recycle timers, and high efficiencies mean that this Trane chiller is the perfect choice for tight temperature control in almost any application temperatures, and under widely varying loads.

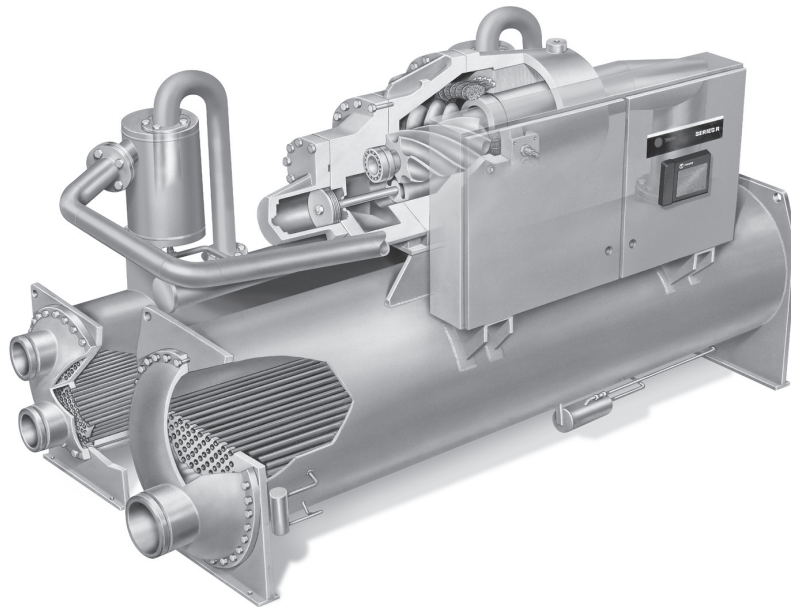

Copyright

This document and the information in it are the property of Trane, and may not be used or reproduced in whole or in part without written permission. Trane reserves the right to revise this publication at any time, and to make changes to its content without obligation to notify any person of such revision or change.

Trademarks

All trademarks referenced in this document are the trademarks of their respective owners.

Revision History

- Added 575V application information for units with optional AFD.
- Incorporated E3G3G3 configuration.
- Updated electrical connection drawings for units with AFD option.



Table of Contents

Introduction	2
Features and Benefits	5
Application Considerations	8
Model Number Descriptions	12
General Data	14
Controls	19
Electrical	21
Electrical Connections	24
Dimensions and Weights	32
Mechanical Specifications	42



Features and Benefits

Application Versatility and High Performance

- Optional AdaptiSpeed™ technology assures optimal performance at all operating conditions
 - Adaptive Frequency™ Drive - Soft start provided as standard to reduce power in-rush at start-up
- Screw compressor technology and the electronic expansion valve provide reliable performance in an expanded range of operating temperatures.
- Tight water temperature control extends to operation of multiple chillers in parallel or series configurations, offering further system design flexibility for maximum efficiency.
- Evaporator piping water volumes can be as small as two minutes of loop time minimizing the need for buffer tank capacity.
- Extensive information on professional design selection and layout is available in a highly readable, electronic format.
- Industrial / Low Temperature Process Cooling - Excellent operating temperature range and precise control capabilities enable tight control with single chiller or series configuration.
- Ice/Thermal Storage - Specifiers and operators benefit from dual setpoint control and industry-leading temperature, efficiency, and control capabilities, plus outstanding support through partnership with Calmac, a strong Trane partner providing proven installation examples, templates, and references that minimize design time, energy costs, and operating costs.
- Heat Recovery – Minimizes operating costs for the chilled water plant and boiler/hot water heater, while providing consistent dehumidification.
- Rapid Restart™ capability minimizes downtime.

Simple, Economical Installation

- Compact size makes the model RTHD well suited for the retrofit and replacement market.
- Units with wye-delta starters fit through standard double width doors. Bolt-together construction makes for fast, unit disassembly.
- Small footprint saves valuable equipment room space and alleviates access concerns for most retrofit jobs.
- Lightweight design simplifies rigging requirements, further reducing installation time requirements and costs.
- Full factory refrigerant or nitrogen and oil charges reduce required field labor, materials, and installation cost.
- Only evaporator and condenser water piping is required; no water-cooled starter or drive (with its associated safety concerns) or field piping is necessary.
- Purge system connections have been eliminated. Factory-installed and wired control power transformer powers the chiller unit controls. Simple single-point power connection simplifies overall installation.
- Factory installed and tested starter for wye-delta and Adaptive Frequency Drive (AFD) eliminates additional jobsite installation considerations and labor requirements.
- Trane has conducted extensive factory testing, and also offers options for in person and/or documented chiller performance verification.
- Tracer AdaptiView™ TD7 controls interface with Tracer® SC, LonTalk®, BACnet® or Modbus™ building automation systems.



Features and Benefits

State-of-the-Art, Precision Control

- New 7 inch color touch screen display with graphics
- Powered by UC800 industry-leading control algorithms
 - Enhanced flow management provides unmatched system performance in variable flow water systems
- Adaptive Control™ keeps the chiller running in extreme conditions
 - Tight set point control
 - Graphical trending
 - Maximized chiller update
- BACnet®, Modbus™, LonTalk® communications capability provides excellent, trouble-free interoperability.
- Generic Building Automation System points are available for easy access to operational information.
- Advanced design enables chilled water temperature control to +/- 0.5°F (.28°C) for flow changes up to 10 percent per minute, plus handling of flow changes up to 30 percent per minute for comfort cooling.
- Two-minute stop-to-start and five-minute start-to-start anti-recycle timer allows tight chilled water temperature control in constant or transient low-load applications.

Reliability and Ease of Maintenance

- Direct drive, low-speed compressor – a simple design with only three moving parts – provides maximum efficiency, high reliability, and low maintenance requirements.
- Electronic expansion valve, with fewer moving parts than alternative valve designs, offers highly reliable operation.
- Suction gas-cooled motor stays uniformly cool at lower temperatures for longer motor life.
- The Trane helical-rotary compressor is a proven design resulting from years of research and thousands of test hours, including extensive testing under extraordinarily severe operating conditions.
- Trane is the world's largest manufacturer of large helical-rotary compressors, with hundreds of thousands of commercial and industrial installations worldwide.

Operating and Life Cycle Cost-Effectiveness

- Industry-leading efficiency
 - Up to 39% higher part load efficiency than ASHRAE 90.1-2013, minimizes power usage.
- Robust drive design using film capacitors for longer drive life.
- High power factor at all load points reduce the need for power factor correction capacitors.
- Electronic expansion valve enables exceptionally tight temperature control and extremely low superheat, resulting in more efficient full-load and part-load operation than previously available.
- Precise compressor rotor tip clearance ensures optimal efficiency.
- Condenser and evaporator tubes use the latest heat transfer technology for increased efficiency.
- The chiller includes optional electrical demand limiting.
- Chilled water reset based on return water temperature is standard.
- High compressor lift capabilities and tight chilled water temperature control allow highly efficient system design with minimal operational concerns.

- The falling-film evaporator, developed by Trane, increases energy efficiency and minimizes refrigerant charge.

Design capabilities include:

- Variable-primary flow
- Series chiller arrangements for evaporator and/or condenser
- Low evaporator and condenser flow



Application Considerations

Condenser Water Temperatures

With the model RTHD chiller, condenser head pressure control is necessary only if the unit starts with leaving condenser water temperatures below 45°F (7.2°C) or cannot rise to 55°F (12.8°C) within 10 minutes.

When the application requires startup temperatures below the prescribed minimums, a variety of system implementation options are available. Here are two recommended methods to control the unit operating conditions for the purpose of refrigerant differential pressure control.

1. Condenser Entering Water Temperature Control
 - Tower bypass may also be a valid control method if the chiller temperature requirements can be maintained and the loop is small.
2. Condenser Water Flow Control
 - To control a 2-way or 3-way valve, select the Condenser Regulating Valve Control option for the Tracer[®] UC800 controls. This option enables the UC800 controls to send an analog electronic signal for opening and closing the valve as necessary to maintain chiller differential refrigerant pressure. The 2-way valves are available as a ship-with option.

The minimum acceptable refrigerant pressure differential between condenser and evaporator is 23 psid (158.6 kPa) at all load conditions in order to ensure adequate oil circulation. The condenser and evaporator pressure differential must be 15 psid (103.4 kPa) within 2 minutes of start up. This equates to the condenser leaving water temperature being 14°F (7.8°C) higher than evaporator leaving water temperature within 2 minutes of startup at typical operating conditions.

Trane chillers start and operate successfully and reliably over a range of load conditions with controlled condenser pressure. Reducing the condenser water temperature is an effective method of lowering chiller power input required, but the ideal temperature for optimizing total system power consumption will depend on the overall system dynamics. From a system perspective, some improvements in chiller efficiency may be offset by the increased tower fan and pumping costs required to achieve the lower tower temperatures. Contact your local Trane systems solution provider for more information on optimizing system performance.

Variable Evaporator Flow and Short Evaporator Water Loops

Variable evaporator flow is an energy-saving design strategy which has quickly gained acceptance as advances in chiller and controls technology have made it possible. With its superior unloading compressor design and advanced UC800 controls, the chiller has excellent capability to maintain leaving water temperature control within +/-0.5°F (0.28°C), even for systems with variable evaporator flow.

Some basic rules should be followed whenever using these system design and operational savings methods with the chiller. The proper location of the chilled water temperature control sensor is in the supply (outlet) water. This location allows the building to act as a buffer, and it assures a slowly changing return water temperature. If there is insufficient water volume in the system to provide an adequate buffer, temperature control can be lost, resulting in erratic system operation and excessive compressor cycling. To ensure consistent operation and tight temperature control, the chilled water loop should be at least two minutes. If this recommendation cannot be followed, and tight leaving water temperature control is necessary, a storage tank or larger header pipe should be installed to increase the volume of water in the system.

For variable-primary flow (VPF) applications, the rate of chilled water flow change should not exceed 10 percent of design per minute to maintain +/- 0.5°F (0.28°C) leaving evaporator temperature control. For applications in which system energy savings is most important and tight temperature control is classified as +/-2°F (1.1°C), up to 30 percent change in flow per minute are possible. Flow rates should be maintained between the minimum and maximum allowed for any particular chiller configuration.

With the help of a software analysis tool such as System Analyzer™, TRACE™, or EnergyPlus™, you can determine whether the anticipated energy savings justify the use of variable-primary flow in a particular application. Existing constant flow chilled water systems may be relatively easily converted to VPF and benefit greatly from the inherent efficiency advantages.

Series Chiller Arrangements

Another energy-saving strategy is to design the system around chillers arranged in series, on the evaporator, condenser, or both. It is possible to operate a pair of chillers more efficiently in a series chiller arrangement than in a parallel arrangement. It is also possible to achieve higher entering-to-leaving chiller differentials, which may, in turn, provide the opportunity for lower chilled water design temperature, lower design flow, and resulting installation and operational cost savings (including downsizing a chiller).

The Trane screw compressor also has excellent “lift” capabilities which afford an opportunity for savings on the evaporator and condenser water loops. Like series arrangements on the evaporator, series arrangements on the condenser may enable savings. This approach may allow reductions in pump and tower installation and operating costs.

Maximizing system efficiency requires that the designer balance performance considerations for all system components; the best approach may or may not involve multiple chillers, or series arrangement of the evaporators and/or condensers. This ideal balance of design integrity with installation and operating cost considerations should be researched by consulting a Trane systems solutions provider and applying the TRACE building energy and economic analysis program.

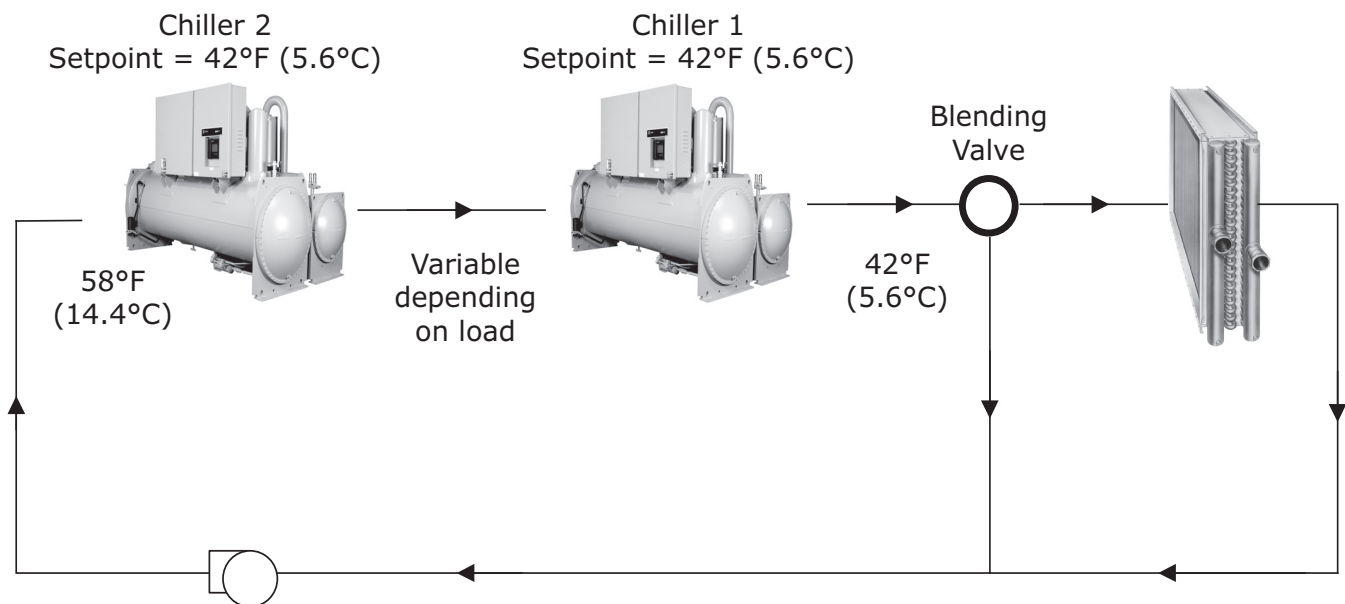

Dry Cooler

The RTHD can be used with dry coolers. Generally this application is selected to minimize the spread of airborne contaminants associated with open tower systems. In addition, other drawbacks of cooling towers are avoided: water consumption, production of vapor, need of water treatment, etc. Another benefit of dry coolers is the ability to operate in low ambient conditions. With the use of a third party heat exchanger this design can also be used to provide free cooling to the chilled water loop during cold weather.

Heat Recovery

At a time when energy costs are high and continue to rise, reducing energy usage has become increasingly important. By using a RTHD chiller with heat recovery, utilization of energy can be improved by using heat from the condenser that would otherwise be wasted. Leaving condenser water control option provides the ability to control the heating setpoint up to 114°F (45.6°C).

The use of heat recovery should be considered in any building with simultaneous heating and cooling requirements or in facilities where heat can be stored and used at a later time. Buildings with high year-round internal cooling loads are excellent opportunities for heat recovery. Heat recovery can be accomplished with the RTHD by recovering heat from the water leaving the standard condenser and using it in conjunction with a third party heat exchanger.

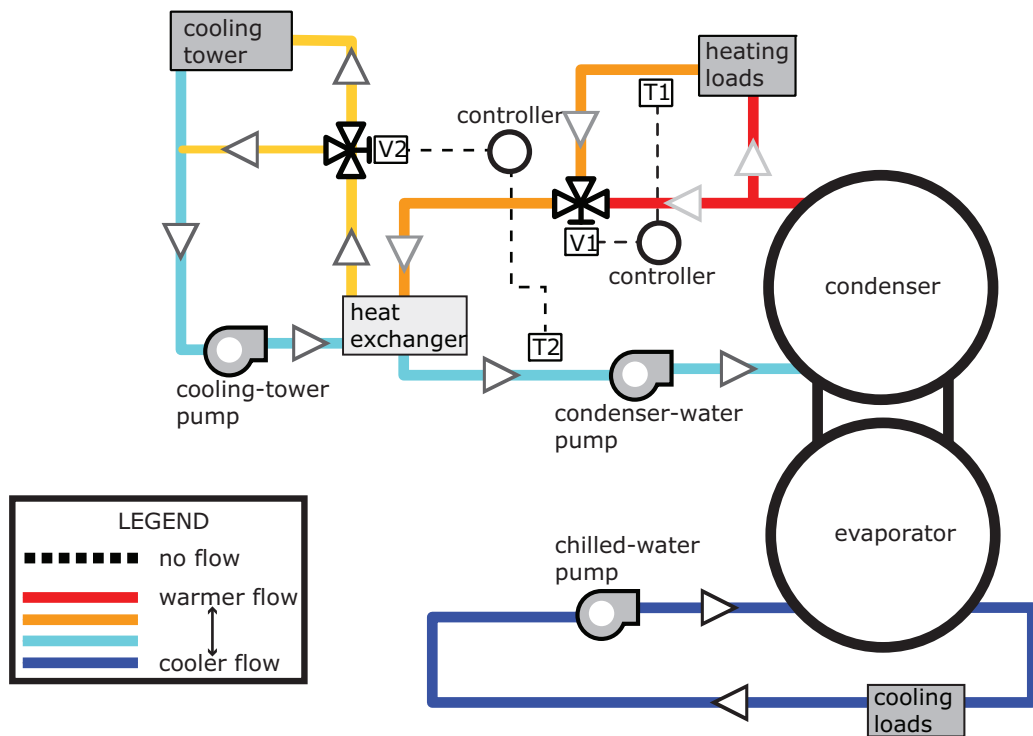

Water Treatment

The use of untreated or improperly treated water in chillers may result in scaling, erosion, corrosion, and algae or slime buildup. It is recommended that the services of a qualified water treatment specialist be engaged to determine what treatment, if any, is advisable.

Water Pumps

Where noise limitation and vibration-free operation are important, Trane strongly encourages the use of 1750-rpm (60 Hz) [1450-rpm (50 Hz)] pumps. Specifying or using 3600-rpm (60 Hz) [3000-rpm (50 Hz)] condenser water and chilled water pumps must be avoided, because such pumps may operate with objectionable levels of noise and vibration. In addition, a low frequency beat may occur due to the slight difference in operating rpm between 3600-rpm (60 Hz) [3000-rpm (50 Hz)] water pumps and chiller motors.

Note: *The chilled water pump must not be used to stop the chiller.*

Acoustic Considerations

For chiller sound ratings, installation tips, and considerations on chiller location, pipe isolation, etc., see the *Water-Cooled Chillers Sound Ratings and Installation Guide*.



Model Number Descriptions

Digits 1 - 4 – Chiller Model

RTHD= Water-Cooled Optimus™ Chiller

Digit 5 – Manufacturing Location

U = Water Chiller Business Unit, Pueblo, CO USA

Digits 6, 7 – Compressor Frame

B1 = B1 Compressor
B2 = B2 Compressor
C1 = C1 Compressor
C2 = C2 Compressor
D1 = D1 Compressor
D2 = D2 Compressor
D3 = D3 Compressor (50 hz only)
E3 = E3 Compressor (50 hz only)

Digits 8 – Unit Power Supply

A = 200V/60Hz/3Ph power
C = 230V/60Hz/3Ph power
D = 380V/60Hz/3Ph power
F = 460V/60Hz/3Ph power
H = 575V/60Hz/3Ph power
R = 380V/50Hz/3Ph power
T = 400V/50Hz/3Ph power
U = 415V/50Hz/3Ph power

Digit 9 – Specials

X = No Specials

Digit 10, 11 – Design Sequence

** = Factory assigned

Digit 12 – Agency Listing

X = No Agency Listing
U = UL Listed to US and Canadian Safety Standard
A = IBC Seismically Rated
B = UL/Canadian and IBC
C = OSHPD Seismically Rated
D = UL/Canadian and OSHPD

Note: Digit 12 selections A, B, C & D are special order only.

Digit 13 – Pressure Vessel Code

A = ASME Pressure Vessel Code
C = Canadian Code
D = Australian Code
L = Chinese Code-Imported Pressure Vessel

Digits 14,15 – Evaporator

B1 = B1 Evaporator
B2 = B2 Evaporator
C1 = C1 Evaporator
C2 = C2 Evaporator
D1 = D1 Evaporator
D2 = D2 Evaporator
D3 = D3 Evaporator
D4 = D4 Evaporator
D5 = D5 Evaporator
D6 = D6 Evaporator
E1 = E1 Evaporator
F1 = F1 Evaporator
F2 = F2 Evaporator
G1 = G1 Evaporator
G2 = G2 Evaporator
G3 = G3 Evaporator

Digit 16 – Evaporator Tube Type

A = Enhanced fin copper (all fluids)
W = Enhanced fin copper (water only)

Digit 17 – Evaporator Water Pass Configuration

2 = 2 Pass
3 = 3 Pass
4 = 4 Pass

Digit 18 – Evaporator Water Connection

L = Left Hand
R = Right Hand

Digit 19 – Evaporator Connection Type

A = Standard Grooved Pipe

Digit 20 – Evaporator Water Side Pressure

L = 150 psi (10.5 bar)
H = 300 psi (21 bar)

Digit 21, 22 – Condenser

B1 = B1 Condenser
B2 = B2 Condenser
D1 = D1 Condenser
D2 = D2 Condenser
E1 = E1 Condenser
E2 = E2 Condenser
E3 = E3 Condenser
E4 = E4 Condenser
E5 = E5 Condenser
F1 = F1 Condenser
F2 = F2 Condenser
F3 = F3 Condenser
G1 = G1 Condenser
G2 = G2 Condenser
G3 = G3 Condenser

Digit 23 – Condenser Tube Type

A = Enhanced Fin Copper - 0.028"
B = Smooth Bore Copper
C = Smooth Bore CuNi
D = Enhanced Fin Copper - 0.025"

Digit 24 – Condenser Water Passes

2 = 2 Pass

Digit 25 – Condenser Water Connection

L = Left Hand
R = Right Hand

Digit 26 – Condenser Connection Type

A = Standard Grooved Pipe
C = Marine
S = Special

Digit 27 – Condenser Waterside Pressure

L = 150 psi (10.5 bar)
H = 300 psi (21 bar)

Digit 28 – Condenser Leaving Water Temperature

A = Standard

Digit 29 – Refrigerant Isolation Valves

X = No Refrigerant Isolation Valves
V = With Refrigerant Isolation Valves

Digit 30 – Oil Cooler

X = Without Oil Cooler
C = With Oil Cooler

Digit 31 – Thermal Insulation

X = No Insulation
Q = Factory Installed Insulation

Digit 32 – Acoustic Insulation

X = No Insulation

Digit 33 – Label and Literature Language

C = Spanish
E = English
F = French

Digit 34 – Safety Devices

X = Standard

Digit 35 – Factory Charge

A = Factory Refrigerant Charge (R-134a)
B = Factory Nitrogen Charge

Digit 36 – Shipping Package

A = No Skid (Standard)
B = Shrink Wrap
C = Skid
D = Skid + Shrink Wrap

Digit 37 – Flow Switch

X = No Flow Switch
A = Evaporator (NEMA 1)
B = Evaporator and Condenser (NEMA 1)
C = Evaporator (NEMA 4)
D = Evaporator and Condenser (NEMA 4)

Digit 38 – Factory Test

- X = Standard Test
- C = Witness Test
- D = Performance Test

Digit 39 – Starter Type

- Y = Wye-Delta Closed Transition Starter
- V = Premium AFD

Digits 40 - 42 – Design RLA (for starter)

- *** = Selection Assigned

Digit 43 – Power Line Connection Type

- A = Terminal Block
- B = Mechanical Disconnect Switch
- D = Circuit Breaker
- F = High Interrupt Circuit Breaker

Digit 44 – Max RLA (Starter)

- C = 277 max RLA (Fixed Speed)
- E = 364 max RLA (Fixed Speed)
- G = 126 max RLA (Drive and Panel)
- H = 150 max RLA (Drive and Panel)
- J = 185 max RLA (Drive and Panel)
- K = 234 max RLA (Drive and Panel)
- L = 279 max RLA (Drive and Panel)
- M = 316 max RLA (Drive and Panel)
- N = 366 max RLA (Drive and Panel)
- Q = 397 max RLA (Fixed Speed)
- R = 476 max RLA (Fixed Speed)
- T = 598 max RLA (Fixed Speed)
- U = 779 max RLA (Fixed Speed)
- V = 197 max RLA (Drive and Panel)
- W = 241 max RLA (Drive and Panel)
- X = 292 max RLA (Drive and Panel)
- Y = 367 max RLA (Drive and Panel)
- Z = 446 max RLA (Drive and Panel)
- 1 = 549 max RLA (Drive and Panel)
- 2 = 176 max RLA (Drive and Panel)
- 3 = 223 max RLA (Drive and Panel)
- 4 = 280 max RLA (Drive and Panel)
- 5 = 335 max RLA (Drive and Panel)
- 6 = 411 max RLA (Drive and Panel)
- 7 = 455 max RLA (Drive and Panel)

Digit 45 – Under/Over Voltage Protection

- X = None
- U = With Under/Over Voltage Protection

Digit 46 – Operator Interface

- T = Tracer AdaptiView™ TD7 Display

Digit 47 – Digital Communication Interface

- X = None
- 5 = LCI-C (LonTalk®) Interface
- 7 = BACnet® MS/TP
- 8 = Modbus™ Interface

Digit 48 – External Water & Current-Limit Setpoint

- X = None
- 2 = 2–10 Vdc input
- 4 = 4–20 mA input

Digit 49 – External Base Loading

- X = None
- 2 = 2–10 Vdc input
- 4 = 4–20 mA input

Digit 50 – Ice Making

- X = None
- A = Ice Making with Relay
- B = Ice Making without Relay

Digit 51 – Programmable Relays

- X = None
- R = With Programmable Relays

Digit 52 – Chilled Water Reset

- X = Chilled Water Reset - Return Water
- T = Chilled Water Reset - Outdoor Air Temperature

Digit 53 – Control Outputs

- X = None
- D = Chiller Differential Pressure & Percent RLA
- P = Condenser Pressure (% HPC) & Percent RLA
- V = Condenser Regulating Valve Control & Percent RLA

Digits 54 – Refrigerant Monitor

Input

- X = None
- A = 100 ppm / 4-20 mA
- B = 1000 ppm / 4-20 mA
- C = 100 ppm / 2-10 Vdc
- D = 1000 ppm / 2-10 Vdc

Digit 55 – Condenser Leaving Hot Water Temp Control

- X = None
- H = Hot Water Temp Control

Digits 56 - 58 – AFD Output

Amps

- 000 = Not Applicable (wye-delta starter)
- *** = Selection Assigned (when AFD option selected)



General Data

Table 1. Nominal capacity data

Nominal Compressor	B1	B2	C1	C2	D1	D2	D3	E3
60 Hz Tonnage	175-200	200-225	225-275	275-325	325-400	375-450	n/a	n/a
50 Hz Tonnage	125-150	150-175	175-225	225-275	275-325	300-350	325-375	375-450

Notes:

1. Chiller selections can be optimized through the use of the AHRI certified TOPSS™ selection program by contacting your local Trane account manager.
2. Compressor configuration is shown in unit model number digits 6, 7.

Table 2. Water storage, refrigerant and oil charge

Unit Configuration			Evaporator Water Storage		Condenser Water Storage		Refrigerant R-134a Charge		Oil Charge ^(a)					
									Standard Units			Unit with AFD Option		
Comp ^(b)	Evap ^(c)	Cond ^(d)	gal	L	gal	L	lb	kg	Type	gal	L	Type	gal	L
B1	B1	B1	41	155	28	106	410	186		4.5	17		7.5	28.5
B1	C1	D1	55	208	31	117	490	222		4.5	17		7.5	28.5
B2	B2	B2	45	170	29	110	410	186		4.5	17		7.5	28.5
B2	C2	D2	58	220	34	129	490	222		4.5	17		7.5	28.5
C1	D6	E5	45	170	29	110	490	222		6	23		10	38
C1	D5	E4	52	197	32	121	490	222		6	23		10	38
C1	E1	F1	82	310	60	226	525	238		10	38		11	42
C2	D4	E4	52	197	32	121	490	222		6	23		10	38
C2	D3	E3	78	295	47	175	490	222		6	23		10	38
C2	F2	F3	107	405	61	231	625	284		10	38		12	45.5
D1	D1	E1	69	261	44	166	475	216	OIL048	6	23	OIL315	9.5	36
D1	F1	F2	102	386	57	216	625	284		10	38		11	42
D1 ^(e)	G1	G1	136	515	79	299	700	318		11	42		13.5	51
D1 ^(f)	G2	G2	144	545	91	344	700	318		11	42		13.5	51
D2	D2	E2	74	280	47	178	475	216		6	23		9.5	36
D2	F2	F3	107	405	61	231	625	284		10	38		11	42
D2 ^(e)	G2	G1	144	545	79	299	700	318		11	42		13.5	51
D2 ^(f)	G3	G3	159	602	97	367	700	318		11	42		13.5	51
D3/E3 ^(e)	D2	E2	74	280	47	178	475	216		6	23		9.5	36
D3/E3 ^(e)	F2	F3	107	405	61	231	625	284		10	38		11	42
D3/E3 ^(e)	G2	G1	144	545	79	299	700	318		11	42		13.5	51
E3 ^(e)	G3	G3	159	602	97	367	700	318		11	42		13.5	51

(a) If oil cooler is installed, add 0.3 gal (1L) to oil charge value given for B compressor family units. Add 1.0 gal (4L) for all other units.

(b) Unit model number digits 6, 7.

(c) Unit model number digits 14, 15.

(d) Unit model number digits 21, 22.

(e) 50 Hz units only

(f) 60 Hz units only

Table 3. Minimum/maximum evaporator flow rates – water (gpm)

Evaporator Code	Two Pass			Three Pass			Four Pass		
	Nominal Conn. Size (in.)	Min	Max	Nominal Conn. Size (in.)	Min	Max	Nominal Conn. Size (in.)	Min	Max
B1	8	253	1104	6	168	736	-	-	-
B2	8	288	1266	6	198	844	-	-	-
C1	8	320	1412	6	213	941	-	-	-
C2	8	347	1531	6	232	1022	-	-	-
D1	8	415	1812	8	275	1206	-	-	-
D2	8	450	1980	8	300	1320	-	-	-
D3	8	486	2131	8	324	1417	-	-	-
D4	8	351	1542	8	234	1028	-	-	-
D5	8	351	1542	8	234	1028	-	-	-
D6	8	293	1287	8	196	860	-	-	-
E1	8	450	1980	8	300	1320	-	-	-
F1	10	563	2478	8	376	1655	-	-	-
F2	10	604	2667	8	404	1780	-	-	-
G1	-	-	-	10	505	2218	8	379	1666
G2	-	-	-	10	550	2413	8	411	1807
G3	-	-	-	10	622	2732	8	466	2050

Notes:

1. Minimum flow rates are based on **water only**.
2. All water connections are grooved pipe.

Table 4. Minimum/maximum evaporator flow rates – water (l/s)

Evaporator Code	Two Pass			Three Pass			Four Pass		
	Nominal Conn. Size (mm)	Min	Max	Nominal Conn. Size (mm)	Min	Max	Nominal Conn. Size (mm)	Min	Max
B1	200	16	70	150	11	46	-	-	-
B2	200	18	80	150	12	53	-	-	-
C1	200	20	89	150	13	59	-	-	-
C2	200	22	97	150	15	65	-	-	-
D1	200	26	114	200	17	76	-	-	-
D2	200	28	125	200	19	83	-	-	-
D3	200	31	134	200	20	89	-	-	-
D4	200	22	97	200	15	65	-	-	-
D5	200	22	97	200	15	65	-	-	-
D6	200	18	81	200	12	54	-	-	-
E1	200	28	125	200	19	83	-	-	-
F1	250	36	156	200	24	104	-	-	-
F2	250	38	168	200	25	112	-	-	-
G1	-	-	-	250	32	140	200	24	105
G2	-	-	-	250	35	152	200	26	114
G3	-	-	-	250	39	172	200	29	129

Notes:

1. Minimum flow rates are based on **water only**.
2. All water connections are grooved pipe.

General Data

Table 5. Minimum/maximum condenser flow rates – water (gpm)

Condenser Code	Min	Two Pass	
		Max	Connection Size (in)
B1	193	850	6
B2	212	935	6
D1	193	850	6
D2	212	935	6
E1	291	1280	8
E2	316	1390	8
E3	325	1420	8
E4	245	1080	8
E5	206	910	8
F1	375	1650	8
F2	355	1560	8
F3	385	1700	8
G1	444	1960	8
G2	535	2360	8
G3	589	2600	8

Notes:

1. Minimum flow rates are based on **water only**.
2. All water connections are grooved pipe.

Table 6. Minimum/maximum condenser flow rates – water (l/s)

Condenser Code	Min	Two Pass	
		Max	Connection Size (mm)
B1	12	54	150
B2	13	59	150
D1	12	54	150
D2	13	59	150
E1	18	81	200
E2	20	88	200
E3	21	90	200
E4	15	68	200
E5	13	57	200
F1	24	104	200
F2	22	98	200
F3	24	107	200
G1	28	124	200
G2	34	149	200
G3	37	164	200

Notes:

1. Minimum flow rates are based on **water only**.
2. All water connections are grooved pipe.

Table 7. Minimum/maximum evaporator flow rates – brine (gpm)

Evaporator Code	Two Pass			Three Pass			Four Pass		
	Nominal Conn. Size (in.)	Min	Max	Nominal Conn. Size (in.)	Min	Max	Nominal Conn. Size (in.)	Min	Max
B1	8	303	1104	6	200	736	-	-	-
B2	8	346	1266	6	233	844	-	-	-
C1	8	346	1412	6	254	941	-	-	-
C2	8	375	1531	6	276	1022	-	-	-
D1	8	498	1812	8	330	1206	-	-	-
D2	8	541	1980	8	357	1320	-	-	-
D3	8	584	2131	8	389	1417	-	-	-
D4	8	422	1542	8	281	1028	-	-	-
D5	8	422	1542	8	281	1028	-	-	-
D6	8	352	1287	8	233	860	-	-	-
E1	8	487	1980	8	357	1320	-	-	-
F1	10	676	2478	8	454	1655	-	-	-
F2	10	725	2667	8	487	1780	-	-	-
G1	-	-	-	10	606	2218	8	454	1666
G2	-	-	-	10	660	2413	8	492	1807
G3	-	-	-	10	747	2732	8	557	2050

Notes:

1. Minimum flow rates are based on **brine solution**
2. All water connections are grooved pipe.

Table 8. Minimum/maximum evaporator flow rates – brine (l/s)

Evaporator Code	Two Pass			Three Pass			Four Pass		
	Nominal Conn. Size (mm)	Min	Max	Nominal Conn. Size (mm)	Min	Max	Nominal Conn. Size (mm)	Min	Max
B1	200	19	70	150	13	46	-	-	-
B2	200	22	80	150	15	53	-	-	-
C1	200	22	89	150	16	59	-	-	-
C2	200	23	97	150	17	65	-	-	-
D1	200	31	114	200	21	76	-	-	-
D2	200	34	125	200	23	83	-	-	-
D3	200	37	134	200	25	89	-	-	-
D4	200	27	97	200	18	65	-	-	-
D5	200	27	97	200	18	65	-	-	-
D6	200	22	81	200	15	54	-	-	-
E1	200	28	125	200	23	83	-	-	-
F1	250	43	156	200	29	104	-	-	-
F2	250	46	168	200	31	112	-	-	-
G1	-	-	-	250	38	140	200	29	105
G2	-	-	-	250	42	152	200	31	114
G3	-	-	-	250	47	172	200	35	129

Notes:

1. Minimum flow rates are based on **brine solution**
2. All water connections are grooved pipe.



General Data

Table 9. Minimum/maximum condenser flow rates – brine (gpm)

Condenser Code	Min	Two Pass	
		Max	Connection Size (in)
B1	230	850	6
B2	255	935	6
D1	230	850	6
D2	255	935	6
E1	350	1280	8
E2	380	1390	8
E3	390	1420	8
E4	295	1080	8
E5	250	910	8
F1	450	1650	8
F2	430	1560	8
F3	460	1560	8
G1	530	1960	8
G2	650	2360	8
G3	710	2600	8

Notes:

1. Minimum flow rates are based on **brine solution**
2. All water connections are grooved pipe.

Table 10. Minimum/maximum condenser flow rates – brine (l/s)

Condenser Code	Min	Two Pass	
		Max	Connection Size (mm)
B1	15	54	150
B2	16	59	150
D1	15	54	150
D2	16	59	150
E1	22	81	200
E2	24	88	200
E3	25	90	200
E4	19	68	200
E5	16	57	200
F1	28	104	200
F2	27	98	200
F3	29	107	200
G1	33	124	200
G2	41	149	200
G3	45	164	200

Notes:

1. Minimum flow rates are based on **brine solution**
2. All water connections are grooved pipe.



Controls

Tracer AdaptiView™ TD7 Operator Interface

The standard Tracer AdaptiView™ TD7 display provided with the Tracer® UC800 controller features a 7" LCD touch-screen, allowing access to all operational inputs and outputs. This is an advanced interface that allows the user to access any important information concerning setpoints, active temperatures, modes, electrical data, pressure, and diagnostics. It uses full text display available in 26 languages.

Display Features Include:

- LCD touch-screen with LED backlighting, for scrolling access to input and output operating information
- Single-screen, folder/tab-style display of all available information on individual components (evaporator, condenser, compressor, etc.)
- Manual override indication
- Password entry/lockout system to enable or disable display
- Automatic and immediate stop capabilities for standard or immediate manual shutdown
- Fast, easy access to available chiller data in tabbed format, including:
 - Easy to view Operating Modes
 - Logical Sub-Component Reports:
 - Evaporator
 - Condenser
 - Compressor
 - Motor
 - 3 User Programmable Custom Reports
 - ASHRAE report
 - Logsheets Report
 - Alarms Report
 - 8 pre-defined Standard Graphs
 - 4 User Programmable Custom Graphs
 - Chiller Settings
 - Feature Settings
 - Chilled Water Reset
 - Manual Control Settings
 - Globalization Settings
 - Support of 26 languages
 - Brightness Setting
 - Cleaning Mode

Tracer® SC

The Tracer® SC system controller acts as the central coordinator for all individual equipment devices on a Tracer building automation system. The Tracer® SC scans all unit controllers to update information and coordinate building control, including building subsystems such as VAV and chiller water systems. With this system option, the full breadth of Trane's HVAC and controls experience are applied to offer solutions to many facility issues. The LAN allows building operators



Controls

to manage these varied components as one system from any personal computer with web access. The benefits of this system are:

- Improved usability with automatic data collection, enhanced data logging, easier to create graphics, simpler navigation, pre-programmed scheduling, reporting, and alarm logs.
- Flexible technology allows for system sizes from 30-120 unit controllers with any combination of LonTalk® or BACnet® unit controllers.
- LEED certification through site commissioning report, energy data collection measurement, optimizing energy performance, and maintaining indoor air quality.
- Energy savings programs include: fan pressure optimization, ventilation reset, and chiller plant control (adds and subtracts chillers to meet cooling loads).

BACnet® Interface

Tracer AdaptiView™ control can be configured for BACnet® communications at the factory or in the field. This enables the chiller controller to communicate on a BACnet® MS/TP network. Chiller setpoints, operating modes, alarms, and status can be monitored and controlled through BACnet. Tracer AdaptiView™ controls conform to the BACnet® B-ASC profile as defined by ASHRAE 135-2004.

LonTalk® Communications Interface (LCI-C)

The optional LonTalk® Communications Interface for Chillers (LCI-C) is available factory or field installed. It is an integrated communication board that enables the chiller controller to communicate over a LonTalk® network. The LCI-C is capable of controlling and monitoring chiller setpoints, operating modes, alarms, and status. The Trane LCI-C provides additional points beyond the standard LONMARK® defined chiller profile to extend interoperability and support a broader range of system applications. These added points are referred to as open extensions. The LCI-C is certified to the LONMARK® Chiller Controller Functional Profile 8040 version 1.0, and follows LonTalk® FTT-10A free topology communications.

Modbus™ Interface

Tracer AdaptiView™ control can be configured for Modbus™ communications at the factory or in the field. This enables the chiller controller to communicate as a slave device on a Modbus™ network. Chiller setpoints, operating modes, alarms, and status can be monitored and controlled by a Modbus™ master device.

Hardwire Points

Remote devices wired from the control panel are another reliable method of providing auxiliary control to a building automation system. Inputs and outputs can be communicated via a typical 4–20 mA electrical signal, an equivalent 2–10 Vdc signal, or by utilizing contact closures.

Selectable options:

- External chilled water setpoint, external current-limit setpoint
- Condenser leaving hot water temperature control setpoint (available on units with wye-delta starters)
- Ice making control (available on units with wye-delta starters)
- Chilled water temperature reset
- Condenser pressure output
- Motor current analog output
- Programmable relays available outputs are: alarm-latching, alarm-auto reset, general alarm, warning, chiller limit mode, compressor running, head pressure relief request, and Tracer control



Electrical

Standard Units with Wye-Delta Starter

See “Electrical Data Table Information,” p. 22. Electrical component sizing should be based on actual jobsite operating conditions. This factor can be obtained through the use of TOPSS™.

Table 11. Compressor motor electrical data (60 Hz) – standard units (wye-delta starter)

Compressor Code ^(a)	Voltage ^(b)	Max kW	RLA @ Max kW ^(c)	LRA (Wye)	LRA (Delta)
B1, B2	200	174	557	970	3103
	230	174	484	818	2617
	380	174	291	488	1561
	460	174	241	400	1280
	575	174	193	329	1053
C1, C2	200	249	812	1173	3634
	230	249	698	936	2901
	380	249	421	558	1727
	460	249	349	469	1453
	575	249	279	375	1162
D1, D2	200	329	1047	1690	5477
	230	329	918	1532	4966
	380	329	549	850	2755
	460	329	455	730	2366
	575	329	367	612	1984

(a) Unit model number digits 6 & 7.

(b) Voltage utilization ranges: 200V (180-220)m 230V (205-254), 380V (342-418), 460V (414-506), 575V (516-633).

(c) The RLA @ Max kW is based on the performance of the motor developing full rated horsepower.

Table 12. Compressor motor electrical data (50 Hz) – standard units (wye-delta starter)

Compressor Code ^(a)	Voltage ^(b)	Max kW	RLA @ Max kW ^(c)	LRA (Wye)	LRA (Delta)
B1, B2	380	139	233	391	1229
	400	145	233	412	1296
	415	148	233	428	1348
C1, C2	380	201	349	456	1414
	400	209	349	480	1488
	415	213	349	498	1544
D1, D2, D3	380	271	455	711	2303
	400	280	455	748	2424
	415	284	455	776	2515
E3	380	288	488	711	2303
	400	301	488	748	2424
	415	306	488	776	2515

(a) Unit model number digits 6 & 7.

(b) Voltage utilization ranges: 380V (342-418), 400V (360-440), 415V (374-457).

(c) The RLA @ Max kW is based on the performance of the motor developing full rated horsepower.

Electrical Data Table Information

Compressor motor electrical data is provided in [Table 11](#) and [Table 12, p. 21](#) for each compressor size. Rated load amperes (RLA), locked rotor wye amperes (LRA) and expected inrush for the Wye-delta configurations are shown.

Although the terms “LRA” and “expected inrush” are often used interchangeably, the distinction applied here is that LRA is the rated inrush for the motor, but expected inrush is that allowed by the starter, based on the specific configuration. Selecting starters in the Wye-delta configuration lowers expected inrush vs. the Delta (or “across-the-line”) configuration.

The RLA is based on the motor’s performance when reaching full rated horsepower. The kW rating of the motor will equal or exceed the kW requirement indicated by the TOPSS™ selection program at design conditions. If motor kW draw at design conditions is less than the kW rating of the motor, the RLA at design conditions is determined by multiplying the motor RLA (at the desired voltage) by this ratio: design kW/ motor kW rating. This calculation is performed within the computer selection program, making RLA available as part of the design predictions. Predicted values include power factor variation from point to point.

Optimus™ chillers are designed to operate satisfactorily over a utilization range of ±10 percent of the standard design voltages: (a) 200V, 230V, 380V, 460V, and 575V for 60 Hertz, 3-phase, and (b) 380V, 400V, 415V for 50 Hertz, 3-phase.

Units with AFD Option

Table 13. Electrical data - units with AFD

Voltage	Applied Range (Model Number digits 56-58)	Estimated Power Loss (W)
575V 60 Hz	0 - 126	1739
	127 - 150	2099
	151 - 185	2646
	186 - 234	3071
	235 - 279	3719
	280 - 316	4460
	317 - 366	5023
460V 60 Hz	0 - 176	2257
	177 - 223	2719
	224 - 280	3622
	281 - 335	3561
	336 - 411	4558
380V 60 Hz	412 - 455	5703
	0 - 197	2555
	198 - 241	2949
	242 - 292	3764
	293 - 367	4109
380V 50 Hz 400V 50 Hz 415V 50 Hz	368 - 446	5129
	447 - 549	6663
	0 - 197	2555
	198 - 241	2949
	242 - 292	3764
	293 - 367	4109
	368 - 446	5129
	447 - 549	6663

Note: AFD input amps are shown in the RLA field of the unit nameplate.

Electrical Connections

Table 14. Electrical connections

Starter Panel Connection	Selection RLA	Lug Size ^(a) L1-L3 (Each Phase)
Terminals Block	000-598	(2) #4 - 500 MCM
	599-779	n/a
Main Circuit Breaker^(b)	000-200	(1) 3/0 - 350 MCM
	201-476	(2) 2/0 - 500 MCM
	477-640	(3) 3/0 - 500 MCM
	641-779	(4) 3/0 - 500 MCM
Non-Fused Disconnect Switch	000-277	(1) #1 - 600 MCM
	278-397	(2) 2/0 - 500 MCM
	398-598	(3) 3/0 - 500 MCM
	599-779	(4) 3/0 - 500 MCM

(a) Lug sizes are independent of starter type.

(b) Lug sizes are the same for either standard or high interrupt circuit breaker (model number digit 43 = D or F).



Electrical Connections

Units with Wye-Delta Starter

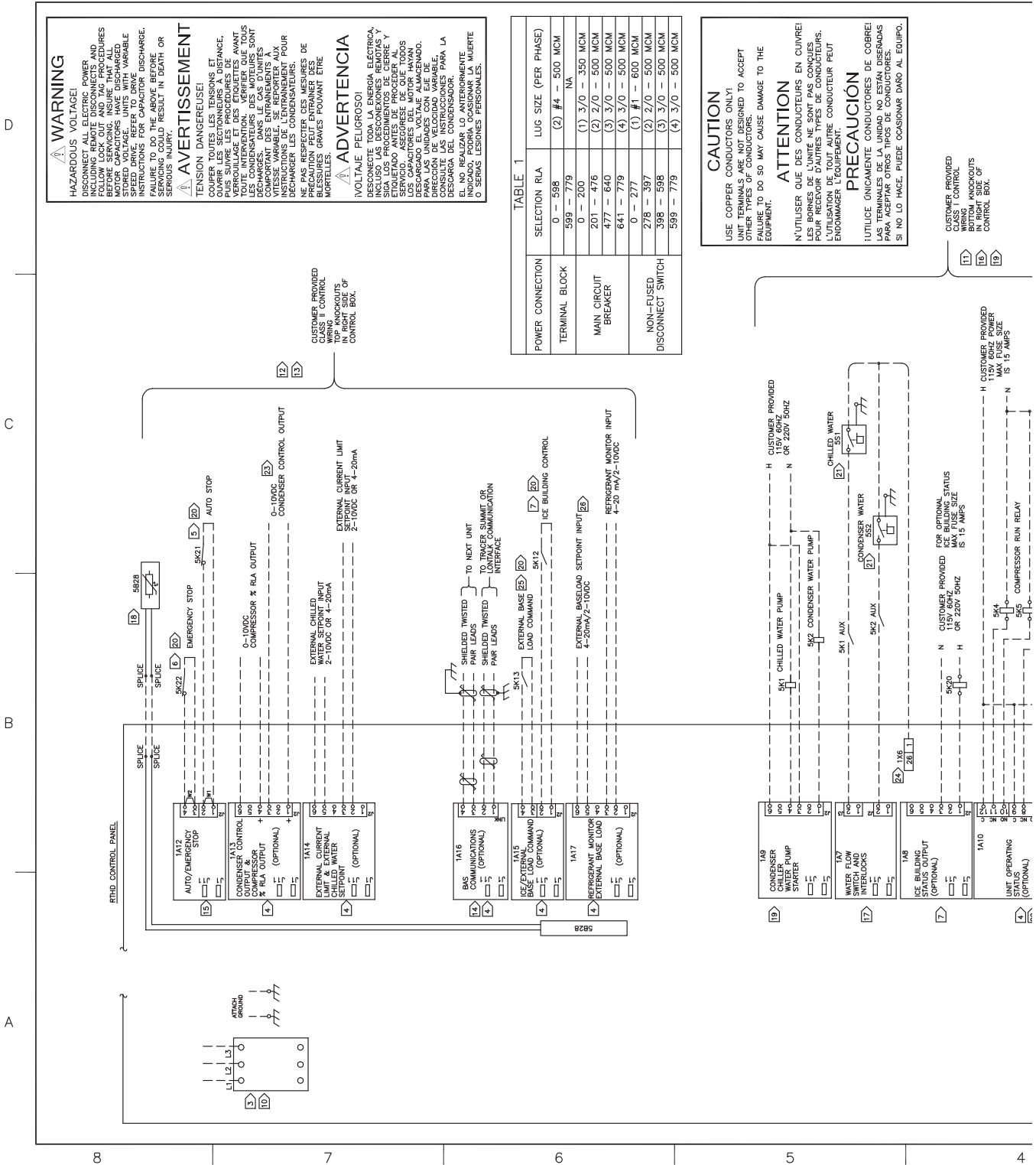

WARNING
HAZARDOUS VOLTAGE!
DISCONNECT ALL ELECTRIC POWER INCLUDING REMOTE DISCONNECTS AND FUSES BEFORE SERVICING. INSURE THAT ALL MOTOR CAPACITORS HAVE DISCHARGED. SPEED DRIVE, REFER TO DRIVE INSTRUCTIONS FOR CAPACITOR DISCHARGE. SERVICING COULD RESULT IN DEATH OR SERIOUS INJURY.

AVERTISSEMENT
TENSION DANGEREUSE!
COUPER TOUTES LES TENSIONS ET QUATRE LES SECTIONNEURS A DISTANCE. PUIS SUIVRE LES PROCEDURES DE MONTRE AVANT TOUTE INTERVENTION. VERIFIER QUE TOUTS LES CONDENSATEURS DES MOTEURS SONT DECHARGES. VITESSE VARIABLE, CONSULTER LES INSTRUCTIONS DE L'ENTRAÎNEMENT POUR DECHARGER LES CONDENSATEURS. LE NE PAS RESPECTER CES MESURES DE SECURITE PEUT RESULTER EN LA MORT O SERIAS LESIONES PERSONALES.

ADVERTENCIA
¡VOLTAJE PELIGROSO!
DESCONECTE TODA LA ENERGIA ELECTRICA INCLUIDO LAS DESCONEXIONES REMOTAS Y FUSIBLES ANTES DE COMENZAR EL SERVICIO. ASEGURESE DE QUE TODOS LOS CONDENSADORES DE LOS MOTORES SEAN DESCARGADOS. VELOCIDAD VARIABLE, CONSULTE LAS INSTRUCCIONES PARA LA DESCARGA DEL CONDENSADOR. EL NO REALIZAR LO ANTERIORMENTE PUEDE RESULTAR EN LA MUERTE O SERIAS LESIONES PERSONALES.

TABLE 1

POWER CONNECTION	SELECTION RLA	LUG SIZE (PER PHASE)
TERMINAL BLOCK	0 - 598	(2) #4 - 500 MCM
	598 - 779	(2) #4 - 500 MCM
MAIN CIRCUIT BREAKER	0 - 200	(1) 3/0 - 350 MCM
	201 - 476	(2) 2/0 - 500 MCM
	477 - 640	(3) 3/0 - 500 MCM
	641 - 779	(4) 3/0 - 500 MCM
NON-FUSED DISCONNECT SWITCH	0 - 277	(1) #1 - 600 MCM
	278 - 397	(2) 2/0 - 500 MCM
	398 - 598	(3) 3/0 - 500 MCM
	599 - 779	(4) 3/0 - 500 MCM

CAUTION
USE COPPER CONDUCTORS ONLY!
OTHER TYPES OF CONDUCTORS ARE NOT PERMITTED TO ACCEPT FAILURE TO DO SO MAY CAUSE DAMAGE TO THE EQUIPMENT.

ATTENTION
N'UTILISER QUE DES CONDUCTEURS EN CUIVRE! LES BORNES DE L'UNITÉ NE SONT PAS CONÇUES POUR RECEVOIR D'AUTRES TYPES DE CONDUCTEURS. L'UTILISATION DE TOUT AUTRE CONDUCTEUR PEUT ENDOMMAGER L'EQUIPEMENT.

PRECAUCION
¡UTILICE UNICAMENTE CONDUCTORES DE COBRE! LAS TERMINALES DE LA UNIDAD NO ESTÁN DISEÑADAS PARA ACEPTAR OTROS TIPOS DE CONDUCTORES. SI NO LO HACE, PUEDE COOSIONAR DAÑO AL EQUIPO.

CUSTOMER PROVIDED CLASS 1 CONTROL WIRING AND KNOCKOUTS IN RIGHT SIDE OF CONTROL BOX.

A B C D

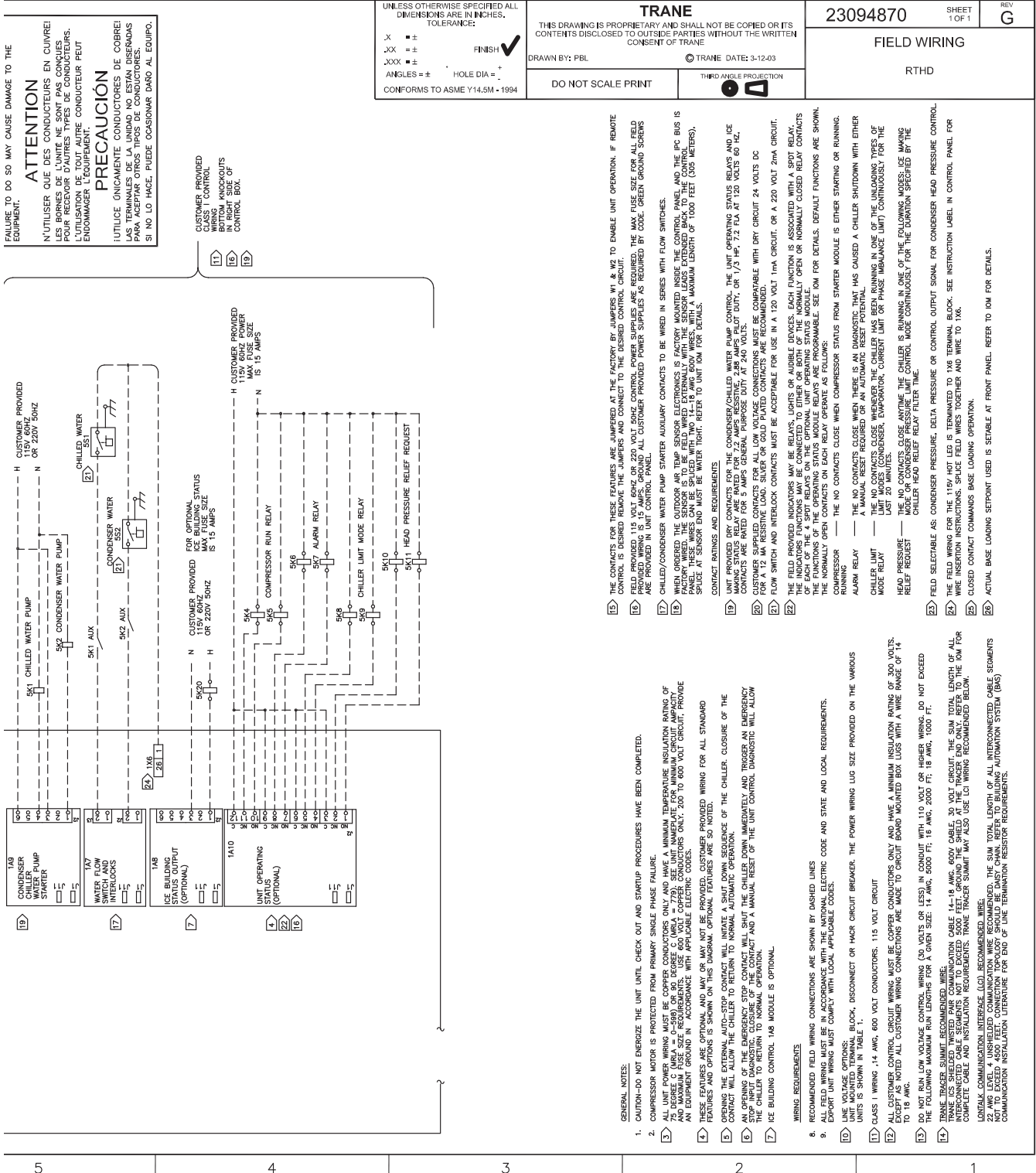

FAILURE TO DO SO MAY CAUSE DAMAGE TO THE EQUIPMENT.

ATTENTION

N'UTILISER QUE DES CONDUCTEURS EN CUIVRE! LES BORNES DE L'UNITÉ NE SONT PAS CONÇUES POUR RECEVOIR D'AUTRES TYPES DE CONDUCTEURS. ENDOUMAGER L'ÉQUIPEMENT.

PRECAUCIÓN

UTILICE ÚNICAMENTE CONDUCTORES DE COBRE! LAS BORNES DE LA UNIDAD NO ESTÁN DISEÑADAS PARA ACEPTAR OTROS TIPOS DE CONDUCTORES. SI, NO LO HACE, PUEDE OCASIONAR DAÑO AL EQUIPO.

CUSTOMER PROVIDED CLASS 1 CONTROL BOTTOM KNOCKOUTS IN RIGHT SIDE OF CONTROL CAB.

UNLESS OTHERWISE SPECIFIED ALL DIMENSIONS ARE IN INCHES. TOLERANCE:

.X ±
.XX ±
.XXX ±
ANGLES ± HOLE DIA = +

FINISH ✓

CONFORMS TO ASME Y14.5M - 1994

TRANE

THIS DRAWING IS PROPRIETARY AND SHALL NOT BE COPIED OR ITS CONTENTS DISCLOSED TO OUTSIDE PARTIES WITHOUT THE WRITTEN CONSENT OF TRANE

DRAWN BY: PBL TRANE DATE: 3-12-03

DO NOT SCALE PRINT THIRD ANGLE PROJECTION

23094870 SHEET 1 OF 1 REV G

FIELD WIRING

RTHD

- 15) THE CONTACTS FOR THESE FEATURES ARE JUMPERED AT THE FACTORY BY JUMBERS IN A WAY TO ENABLE UNIT OPERATION. IF REMOTE CONTROL IS DESIRED, REMOVE JUMBERS AND CONNECT TO THE DESIRED CONTROL CIRCUIT.
- 16) FIELD PROVIDED 115 VOLT 60HZ OR 220 VOLT 50HZ CONTROL POWER SUPPLIES ARE REQUIRED. THE MAX FUSE SIZE FOR ALL FIELD PROVIDED WIRING IS 15 AMPS. GROUND ALL CUSTOMER PROVIDED POWER SUPPLIES AS REQUIRED BY CODE. GREEN GROUND SCREENS ARE PROVIDED IN UNIT CONTROL PANEL.
- 17) CHILLED/CONDENSER WATER PUMP STARTER AUXILIARY CONTACTS TO BE WIRED IN SERIES WITH FLOW SWITCHES.
- 18) WHEN ORDERED THE OUTDOOR AIR TEMP SENSOR ELECTRONICS IS FACTORY MOUNTED INSIDE THE CONTROL PANEL AND THE IPC BUS IS FACTORY WIRING TO THE SENSOR. IF THE CUSTOMER WANTS TO USE A DIFFERENT SENSOR, THE SENSOR MUST BE MOUNTED IN THE CONTROL PANEL. THESE WIRES CAN BE SPliced WITH TWO 14-18 AWG 600V WIRES WITH A MAXIMUM LENGTH OF 1000 FEET (305 METERS). SPlice AT SENSOR END MUST BE WATER TIGHT. REFER TO UNIT FORM FOR DETAILS.
- 19) CHILLED/CONDENSER WATER PUMP STARTER AUXILIARY CONTACTS TO BE WIRED IN SERIES WITH FLOW SWITCHES.
- 20) CUSTOMER SUPPLIED CONTACTS FOR ALL LOW VOLTAGE CONNECTIONS MUST BE COMPATIBLE WITH DRY CIRCUIT 24 VOLTS DC FOR A 12 MA RESISTIVE LOAD. SILVER OR GOLD PLATED CONTACTS ARE RECOMMENDED.
- 21) FLOW SWITCH AND INTERLOCK CONTACTS MUST BE ACCEPTABLE FOR USE IN A 120 VOLT 1MA CIRCUIT OR A 220 VOLT 2MA CIRCUIT.
- 22) THE FIELD PROVIDED INDICATORS MAY BE RELAYS, LIGHTS OR AUDIBLE DEVICES. EACH FUNCTION IS ASSOCIATED WITH A SPOT RELAY. THE INDICATOR FUNCTIONS MAY BE CONNECTED TO EITHER OR BOTH OF THE NORMALLY OPEN OR NORMALLY CLOSED RELAY CONTACTS. THE FUNCTIONS OF THE OPERATING STATUS MODULE RELAYS ARE PROGRAMMABLE. SEE IOM FOR DETAILS. DEFAULT FUNCTIONS ARE SHOWN. THE NORMALLY OPEN CONTACTS ON EACH RELAY OPERATE AS FOLLOWS:
 - COMPRESSOR NO CONTACTS CLOSE WHEN COMPRESSOR STATUS FROM STARTER MODULE IS EITHER STARTING OR RUNNING.
 - ALARM RELAY NO CONTACTS CLOSE WHEN THERE IS AN DIAGNOSTIC THAT HAS CAUSED A CHILLER SHUTDOWN WITH EITHER A MANUAL RESET REQUIRED OR AN AUTOMATIC RESET POTENTIAL.
 - CHILLER LIMIT NO CONTACTS CLOSE WHENEVER THE CHILLER HAS BEEN RUNNING IN ONE OF THE UNLOADING TYPES OF MODE RELAY.
 - HEAD PRESSURE NO CONTACTS CLOSE WHENEVER COMPRESSOR CURRENT LIMIT OR PHASE IMBALANCE LIMIT) CONTINGUOUSLY FOR THE LAST 20 MINUTES.
 - RELIEF REQUEST NO CONTACTS CLOSE ANYTIME THE CHILLER IS RUNNING IN ONE OF THE FOLLOWING MODES: ICE MAKING CHILLER HEAD RELIEF RELAY FILTER TIME.
- 23) FIELD SELECTABLE AS: CONDENSER PRESSURE, DELTA PRESSURE OR CONTROL OUTPUT SIGNAL FOR CONDENSER HEAD PRESSURE CONTROL.
- 24) THE FIELD WIRING FOR THE 115V-HOT LUG IS TERMINATED TO 1/8" TERMINAL BLOCK. SEE INSTRUCTION LABEL IN CONTROL PANEL FOR WIRE INSERTION INSTRUCTIONS. SPlice FIELD WIRES TOGETHER AND WIRE TO 1/8".
- 25) CLOSED CONTACT COMMANDS BASE LOADING OPERATION.
- 26) ACTUAL BASE LOADING SETPOINT USED IS SETABLE AT FRONT PANEL. REFER TO IOM FOR DETAILS.

- 3) CAUTION-DO NOT ENERGIZE THE UNIT UNTIL CHECK OUT AND STARTUP PROCEDURES HAVE BEEN COMPLETED.
 - 4) COMPRESSOR MOTOR IS PROTECTED FROM PRIMARY SINGLE PHASE FAILURE.
 - 5) ALL UNIT POWER WIRES MUST BE COPPER CONDUCTORS ONLY AND HAVE A MINIMUM TEMPERATURE INSULATION RATING OF 90°C (192°F). THE MINIMUM INSULATION RATING FOR ALL WIRING MUST BE IN ACCORDANCE WITH THE NATIONAL ELECTRIC CODE AND STATE AND LOCAL REQUIREMENTS.
 - 6) AN EQUIPMENT GROUND IN ACCORDANCE WITH APPLICABLE ELECTRIC CODES.
 - 7) THESE FEATURES ARE OPTIONAL AND MAY OR MAY NOT BE PROVIDED. CUSTOMER PROVIDED WIRING FOR ALL STANDARD FEATURES AND OPTIONS IS SHOWN ON THIS DIAGRAM. OPTIONAL FEATURES ARE SO NOTED.
 - 8) CONTACT WILL ALLOW THE CHILLER TO RETURN TO NORMAL AUTOMATIC OPERATION.
 - 9) AN OPENING OF THE EMERGENCY STOP CONTACT WILL SHUT THE CHILLER DOWN IMMEDIATELY AND TRIGGER AN EMERGENCY STOP TRIP DIAGNOSTIC. CLOSURE OF THE CONTACT AND A MANUAL RESET OF THE UNIT CONTROL DIAGNOSTIC WILL ALLOW THE CHILLER TO RETURN TO NORMAL OPERATION.
 - 10) ICE BUILDING CONTROL 1A8 MODULE IS OPTIONAL.
- WIRING REQUIREMENTS**
- 11) RECOMMENDED FIELD WIRING CONNECTIONS ARE SHOWN BY DASHED LINES
 - 12) FIELD WIRING MUST BE IN ACCORDANCE WITH THE NATIONAL ELECTRIC CODE AND STATE AND LOCAL REQUIREMENTS.
 - 13) ALL CUSTOMER CONTROL CIRCUIT WIRING MUST BE COPPER CONDUCTORS ONLY AND HAVE A MINIMUM INSULATION RATING OF 300 VOLTS. EXCEPT AS NOTED ALL CUSTOMER WIRING CONNECTIONS ARE MADE TO CIRCUIT BOARD MOUNTED BOX LUGS WITH A WIRE RANGE OF 14 TO 18 AWG.
 - 14) USE VOLTAGE OPTIONS.
 - 15) UNIT MOUNTED TERMINAL BLOCK, DISCONNECT OR HACR CIRCUIT BREAKER. THE POWER WIRING LUG SIZE PROVIDED ON THE VARIOUS UNITS IS SHOWN IN TABLE 1.
 - 16) CLASS 1 WIRING, 14 AWG, 600 VOLT CONDUCTORS, 115 VOLT CIRCUIT
 - 17) ALL CUSTOMER CONTROL CIRCUIT WIRING MUST BE COPPER CONDUCTORS ONLY AND HAVE A MINIMUM INSULATION RATING OF 300 VOLTS. EXCEPT AS NOTED ALL CUSTOMER WIRING CONNECTIONS ARE MADE TO CIRCUIT BOARD MOUNTED BOX LUGS WITH A WIRE RANGE OF 14 TO 18 AWG.
 - 18) TRANE TRACER SUMMIT RECOMMENDED WIRE: 14 AWG, 600V (150 VOLT) IN CONDUIT WITH 110 WIRE OR HARPER WIRE. DO NOT EXCEED THE FOLLOWING MAXIMUM RUN LENGTHS FOR A GROUND SIZE: 14 AWG, 4000 FT; 18 AWG, 2000 FT; 18 AWG, 1000 FT.
 - 19) TRANE TRACER SUMMIT RECOMMENDED WIRE: 14 AWG, 600V (150 VOLT) IN CONDUIT WITH 110 WIRE OR HARPER WIRE. DO NOT EXCEED THE FOLLOWING MAXIMUM RUN LENGTHS FOR A GROUND SIZE: 14 AWG, 4000 FT; 18 AWG, 2000 FT; 18 AWG, 1000 FT.
 - 20) TRANE TRACER SUMMIT RECOMMENDED WIRE: 14 AWG, 600V (150 VOLT) IN CONDUIT WITH 110 WIRE OR HARPER WIRE. DO NOT EXCEED THE FOLLOWING MAXIMUM RUN LENGTHS FOR A GROUND SIZE: 14 AWG, 4000 FT; 18 AWG, 2000 FT; 18 AWG, 1000 FT.
 - 21) COMPLETE CABLE AND INSTALLATION REQUIREMENTS. TRANE TRACER SUMMIT MAY ALSO USE LUG WIRING RECOMMENDED BELOW.
 - 22) LONGTALK COMMUNICATION INTERFACE (LGI) RECOMMENDED WIRE: 14 AWG, 600V (150 VOLT) IN CONDUIT WITH 110 WIRE OR HARPER WIRE. DO NOT EXCEED THE FOLLOWING MAXIMUM RUN LENGTHS FOR A GROUND SIZE: 14 AWG, 4000 FT; 18 AWG, 2000 FT; 18 AWG, 1000 FT.
 - 23) LONGTALK COMMUNICATION INTERFACE (LGI) RECOMMENDED WIRE: 14 AWG, 600V (150 VOLT) IN CONDUIT WITH 110 WIRE OR HARPER WIRE. DO NOT EXCEED THE FOLLOWING MAXIMUM RUN LENGTHS FOR A GROUND SIZE: 14 AWG, 4000 FT; 18 AWG, 2000 FT; 18 AWG, 1000 FT.
 - 24) LONGTALK COMMUNICATION INTERFACE (LGI) RECOMMENDED WIRE: 14 AWG, 600V (150 VOLT) IN CONDUIT WITH 110 WIRE OR HARPER WIRE. DO NOT EXCEED THE FOLLOWING MAXIMUM RUN LENGTHS FOR A GROUND SIZE: 14 AWG, 4000 FT; 18 AWG, 2000 FT; 18 AWG, 1000 FT.
 - 25) LONGTALK COMMUNICATION INTERFACE (LGI) RECOMMENDED WIRE: 14 AWG, 600V (150 VOLT) IN CONDUIT WITH 110 WIRE OR HARPER WIRE. DO NOT EXCEED THE FOLLOWING MAXIMUM RUN LENGTHS FOR A GROUND SIZE: 14 AWG, 4000 FT; 18 AWG, 2000 FT; 18 AWG, 1000 FT.
 - 26) LONGTALK COMMUNICATION INTERFACE (LGI) RECOMMENDED WIRE: 14 AWG, 600V (150 VOLT) IN CONDUIT WITH 110 WIRE OR HARPER WIRE. DO NOT EXCEED THE FOLLOWING MAXIMUM RUN LENGTHS FOR A GROUND SIZE: 14 AWG, 4000 FT; 18 AWG, 2000 FT; 18 AWG, 1000 FT.



Electrical Connections

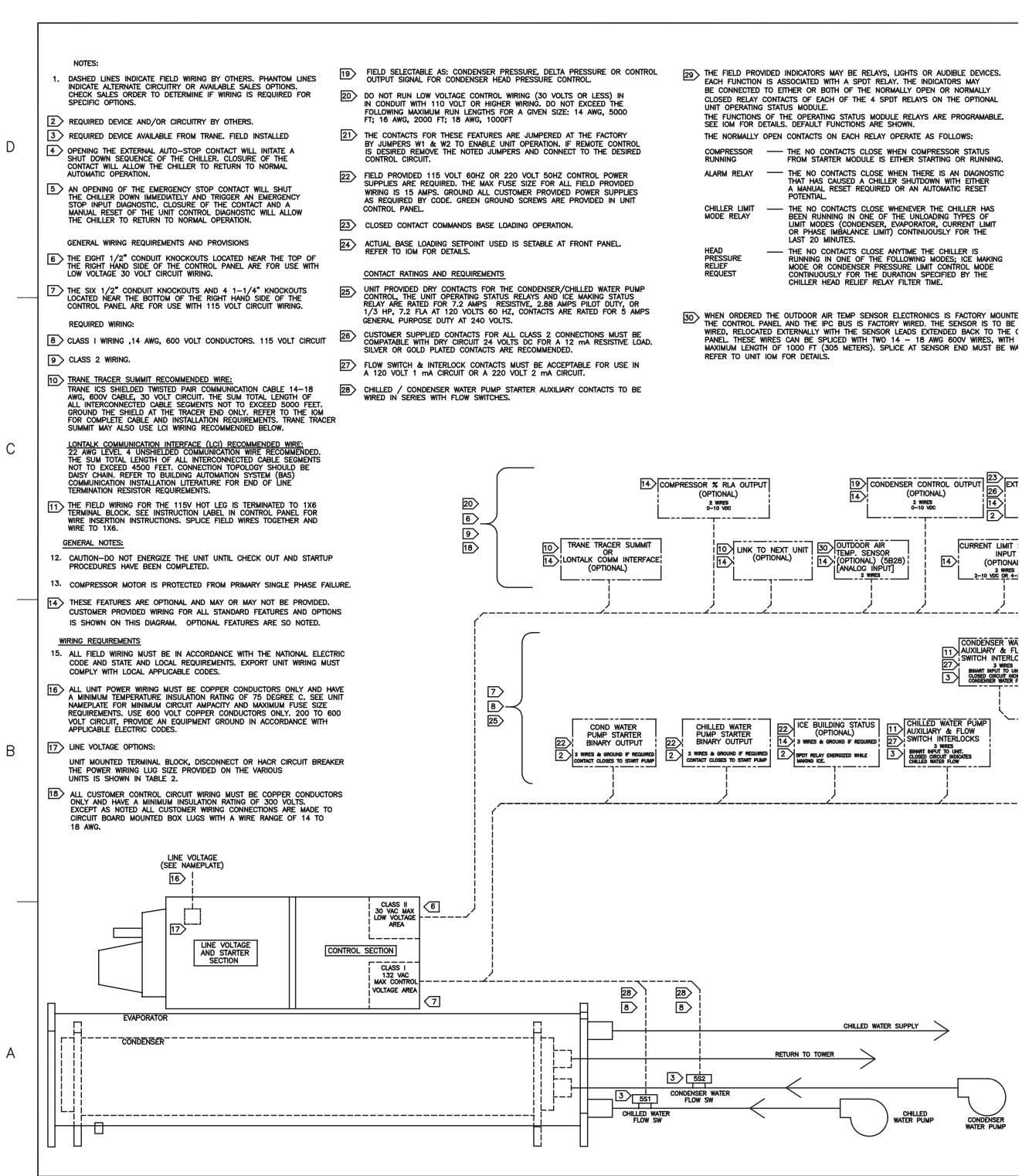

Units with AFD Option

TRANE <small>FOR DETAILS SEE THE UNIT'S PARTS LIST OR CONTACT A TRANE REPRESENTATIVE</small> DRAWN BY: R. SPENCER © TRANE DATE: 11-MAY-2014	23111976 FIELD WIRING DIAGRAM RTHD VSD	REV. SHEET 1 OF 1 B
REVISIONS: REVISION DATE: SIMILAR TO:		

TABLE 1

POWER CONNECTION	SELECTION RLA	LUG SIZE (PER PHASE)
TERMINAL BLOCK	0 - 598	(2) #4 - 500 MCM
	599 - 779	NA
MAIN DISCONNECT BREAKER	0 - 200	(1) 3/0 - 350 MCM
	201 - 478	(2) 2/0 - 500 MCM
	477 - 640	(3) 3/0 - 500 MCM
NON-FUSED DISCONNECT SWITCH	0 - 277	(1) #1 - 600 MCM
	278 - 397	(2) 2/0 - 500 MCM
	398 - 598	(3) 3/0 - 500 MCM

⚠ WARNING
 HAZARDOUS VOLTAGE!
 DISCONNECT ALL ELECTRIC POWER INCLUDING MAIN DISCONNECT BEFORE SERVICING. INSURE THAT ALL POWER IS OFF AND ALL CIRCUITS ARE DEENERGIZED. FOLLOW LOCK OUT AND TAG PROCEDURES. FAILURE TO DO THE ABOVE BEFORE SERVICING COULD RESULT IN DEATH OR SERIOUS INJURY.

⚠ AVERTISSEMENT
 TENSION DANGEREUSE!
 DÉBRANCHER TOUS LES CÂBLAGES ET COUVRIR LES SECTIONNEMENTS À DISTANCE. PLUS SUIVRE LES PROCÉDURES DE MAINTENANCE. ASSURER QUE TOUS LES CÂBLAGES SONT DÉENERGIZÉS. ÉCHÉC À SUIVRE LES PROCÉDURES DE SÉCURITÉ PEUT CAUSER LA MORT OU DES BLESSURES GRAVES.

⚠ ADVERTENCIA
 ¡VOLTAJE PELIGROSO!
 INCLUIR EL DESCONEXIÓN ELÉCTRICA INCLUIDO LAS DESCONEXIONES REMOVIDAS Y EN LA OTRA PARTE DEL MANUAL DE SERVICIO. ASEGURESE DE QUE TODOS LOS CABLES ESTÉN DESCONEXIONADOS Y ETIQUETADOS PARA LAS UNIDADES CON LA DE SERVICIO. CONSULTE LAS INSTRUCCIONES PARA LA SEGURIDAD DEL CONDENSADOR. INCLUIDO: PODRÁ OCASIONAR LA MUERTE O SERIAS LESIONES PERSONALES.

CAUTION
 USE COPPER CONDUCTORS ONLY!
 UNIT TERMINALS ARE NOT DESIGNED TO ACCEPT OTHER TYPES OF CONDUCTORS.
 EQUIPMENT TO DO SO MAY CAUSE DAMAGE TO THE EQUIPMENT.

ATTENTION
 N'UTILISER QUE DES CONDUCTEURS EN CUivre!
 LES BORNES DE L'UNITE NE SONT PAS CONÇUES POUR RECEVOIR D'AUTRES TYPES DE CONDUCTEURS. L'UTILISATION DE TOUT AUTRE CONDUCTEUR PEUT ENDOMMAGER L'ÉQUIPEMENT.

PRECAUCIÓN
 ¡UTILICE ÚNICAMENTE CONDUCTORES DE COBRE!
 LAS BORNES DE LA UNIDAD NO ESTÁN DISEÑADAS PARA ACEPTAR OTROS TIPOS DE CONDUCTORES. SI NO LO HACE, PUEDE OCASIONAR DAÑO AL EQUIPO.

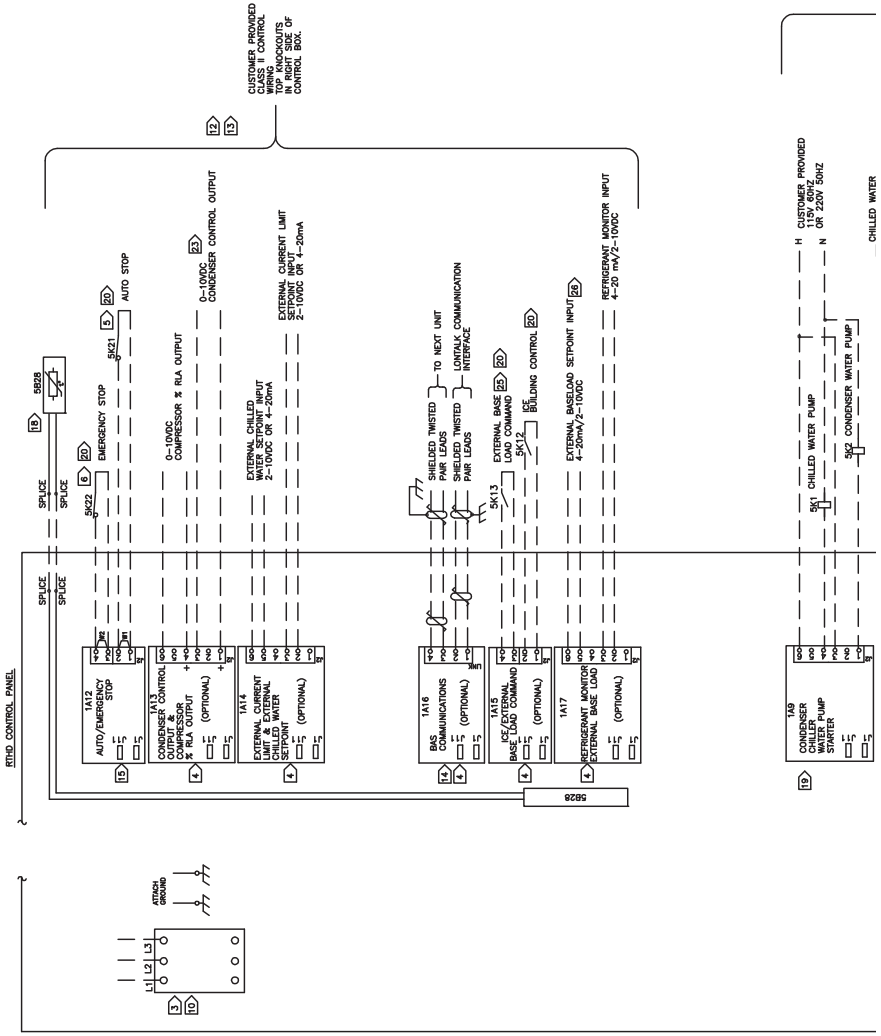

Electrical Connections

A

NOTES:

1. DASHED LINES INDICATE FIELD WIRING BY OTHERS. PHANTOM LINES INDICATE ALTERNATE CIRCUITRY OR AVAILABLE SALES OPTIONS. CHECK SALES ORDER TO DETERMINE IF WIRING IS REQUIRED FOR SPECIFIC OPTIONS.
2. REQUIRED DEVICE AND/OR CIRCUITRY BY OTHERS.
3. REQUIRED DEVICE AVAILABLE FROM TRANE, FIELD INSTALLED.
4. OPENING THE EXTERNAL AUTO-STOP CONTACT WILL INITIATE A SHUT DOWN SEQUENCE OF THE CHILLER. CLOSURE OF THE CONTACT WILL ALLOW THE CHILLER TO RETURN TO NORMAL AUTOMATIC OPERATION.
5. AN OPENING OF THE EMERGENCY STOP CONTACT WILL SHUT THE CHILLER DOWN IMMEDIATELY AND TRIGGER AN EMERGENCY STOP INPUT DIAGNOSTIC. CLOSURE OF THE CONTACT AND A MANUAL RESET OF THE UNIT CONTROL DIAGNOSTIC WILL ALLOW THE CHILLER TO RETURN TO NORMAL OPERATION.

GENERAL WIRING REQUIREMENTS AND PROVISIONS

6. THE EIGHT 1/2" CONDUIT KNOCKOUTS LOCATED NEAR THE TOP OF THE RIGHT HAND SIDE OF THE CONTROL PANEL ARE FOR USE WITH LOW VOLTAGE 30 VOLT CIRCUIT WIRING.
7. THE SIX 1/2" CONDUIT KNOCKOUTS AND 4 1-1/4" KNOCKOUTS LOCATED NEAR THE BOTTOM OF THE RIGHT HAND SIDE OF THE CONTROL PANEL ARE FOR USE WITH 115 VOLT CIRCUIT WIRING.

REQUIRED WIRING:

8. CLASS 1 WIRING, 14 AWG, 600 VOLT CONDUCTORS, 115 VOLT CIRCUIT
9. CLASS 2 WIRING.

TRANE TRACER SUMMIT RECOMMENDED WIRE:

TRANE ICS SHIELDED TWISTED PAIR COMMUNICATION CABLE 14-18 AWG, 800V CABLE, 30 VOLT CIRCUIT. THE SUM TOTAL LENGTH OF ALL INTERCONNECTED CABLE SEGMENTS NOT TO EXCEED 5000 FEET. GROUND THE SHIELD AT THE TRACER END ONLY. REFER TO THE IOM FOR COMPLETE CABLE AND INSTALLATION REQUIREMENTS. TRANE TRACER SUMMIT MAY ALSO USE LC3 WIRING RECOMMENDED BELOW.

LONTALK COMMUNICATION INTERFACE (LCI) RECOMMENDED WIRE:
22 AWG LEVEL 4 UNSHIELDED COMMUNICATION WIRE RECOMMENDED. THE SUM TOTAL LENGTH OF ALL INTERCONNECTED CABLE SEGMENTS NOT TO EXCEED 4500 FEET. CONNECTION TOPOLOGY SHOULD BE DAISY CHAIN. REFER TO BUILDING AUTOMATION SYSTEM (BAS) COMMUNICATION INSTALLATION LITERATURE FOR END OF LINE TERMINATION RESISTOR REQUIREMENTS.

11. THE FIELD WIRING FOR THE 115V HOT LEG IS TERMINATED TO 1X6 TERMINAL BLOCK. SEE INSTRUCTION LABEL IN CONTROL PANEL FOR WIRE INSERTION INSTRUCTIONS. SPLICE FIELD WIRES TOGETHER AND WIRE TO 1X6.

GENERAL NOTES:

12. CAUTION-DO NOT ENERGIZE THE UNIT UNTIL CHECK OUT AND STARTUP PROCEDURES HAVE BEEN COMPLETED.
13. COMPRESSOR MOTOR IS PROTECTED FROM PRIMARY SINGLE PHASE FAILURE.
14. THESE FEATURES ARE OPTIONAL AND MAY OR MAY NOT BE PROVIDED. CUSTOMER PROVIDED WIRING FOR ALL STANDARD FEATURES AND OPTIONS IS SHOWN ON THIS DIAGRAM. OPTIONAL FEATURES ARE SO NOTED.

WIRING REQUIREMENTS

15. ALL FIELD WIRING MUST BE IN ACCORDANCE WITH THE NATIONAL ELECTRIC CODE AND STATE AND LOCAL REQUIREMENTS. EXPORT UNIT WIRING MUST COMPLY WITH LOCAL APPLICABLE CODES.
16. ALL UNIT POWER WIRING MUST BE COPPER CONDUCTORS ONLY AND HAVE A MINIMUM TEMPERATURE INSULATION RATING OF 75 DEGREE C. SEE UNIT NAMEPLATE FOR MINIMUM CIRCUIT AMPACITY AND MAXIMUM FUSE SIZE REQUIREMENTS. USE 600 VOLT COPPER CONDUCTORS ONLY, 200 TO 800 VOLT CIRCUIT. PROVIDE AN EQUIPMENT GROUND IN ACCORDANCE WITH APPLICABLE ELECTRIC CODES.
17. LINE VOLTAGE OPTIONS:
UNIT MOUNTED TERMINAL BLOCK, DISCONNECT OR CIRCUIT BREAKER. POWER WIRING LUG SIZE PROVIDED ON VARIOUS UNITS IS SHOWN IN TABLE 2.
18. ALL CUSTOMER CONTROL CIRCUIT WIRING MUST BE COPPER CONDUCTORS ONLY AND HAVE A MINIMUM INSULATION RATING OF 300 VOLTS. EXCEPT AS NOTED ALL CUSTOMER WIRING CONNECTIONS ARE MADE TO CIRCUIT BOARD MOUNTED BOX LUGS WITH A WIRE RANGE OF 14 TO 18 AWG.

19. FIELD SELECTABLE AS: CONDENSER PRESSURE, DELTA PRESSURE OR CONTROL OUTPUT SIGNAL FOR CONDENSER HEAD PRESSURE CONTROL.

20. DO NOT RUN LOW VOLTAGE CONTROL WIRING (30 VOLTS OR LESS) IN CONDUIT WITH 110 VOLT OR HIGHER WIRING. DO NOT EXCEED THE FOLLOWING MAXIMUM RUN LENGTHS FOR A GIVEN SIZE: 14 AWG, 5000 FT; 16 AWG, 2000 FT; 18 AWG, 1000FT

21. THE CONTACTS FOR THESE FEATURES ARE JUMPERED AT THE FACTORY BY JUMPERS W1 & W2 TO ENABLE UNIT OPERATION, IF REMOTE CONTROL IS DESIRED REMOVE THE NOTED JUMPERS AND CONNECT TO THE DESIRED CONTROL CIRCUIT.

22. FIELD PROVIDED 115 VOLT 60HZ OR 220 VOLT 50HZ CONTROL POWER SUPPLIES ARE REQUIRED. THE MAX FUSE SIZE FOR ALL FIELD PROVIDED WIRING IS 15 AMPS. GROUND ALL CUSTOMER PROVIDED POWER SUPPLIES AS REQUIRED BY CODE. GREEN GROUND SCREWS ARE PROVIDED IN UNIT CONTROL PANEL.

23. CLOSED CONTACT COMMANDS BASE LOADING OPERATION.

24. ACTUAL BASE LOADING SETPOINT USED IS SETABLE AT FRONT PANEL. REFER TO IOM FOR DETAILS.

CONTACT RATINGS AND REQUIREMENTS

25. UNIT PROVIDED DRY CONTACTS FOR THE CONDENSER/CHILLED WATER PUMP CONTROL. THE UNIT OPERATING STATUS RELAYS ARE RATED FOR 7.2 AMPS RESISTIVE, 2.88 AMPS PILOT DUTY, OR 1/3 HP, 17.2 FLA AT 120 VOLTS 60 HZ CONTACTS ARE RATED FOR 5 AMPS GENERAL PURPOSE DUTY AT 240 VOLTS.
26. CUSTOMER SUPPLIED CONTACTS FOR ALL CLASS 2 CONNECTIONS MUST BE COMPATIBLE WITH DRY CIRCUIT 24 VOLTS DC FOR A 12 MA RESISTIVE LOAD. SILVER OR GOLD PLATED CONTACTS ARE RECOMMENDED.
27. FLOW SWITCH & INTERLOCK CONTACTS MUST BE ACCEPTABLE FOR USE IN A 120 VOLT 1 mA CIRCUIT OR A 220 VOLT 2 mA CIRCUIT.
28. CHILLED / CONDENSER WATER PUMP STARTER AUXILIARY CONTACTS TO BE WIRED IN SERIES WITH FLOW SWITCHES.

29. THE FIELD PROVIDED INDICATORS MAY BE RELAYS, LIGHTS OR AUDIBLE DEVICES. EACH FUNCTION IS ASSOCIATED WITH A SPDT RELAY. THE INDICATORS MAY BE CONNECTED TO EITHER OR BOTH OF THE NORMALLY OPEN OR NORMALLY CLOSED RELAY CONTACTS OF EACH OF THE 4 SPDT RELAYS ON THE OPTIONAL UNIT OPERATING STATUS MODULE.

- THE FUNCTIONS OF THE OPERATING STATUS MODULE RELAYS ARE PROGRAMMABLE. SEE IOM FOR DETAILS. DEFAULT FUNCTIONS ARE SHOWN.
- THE NORMALLY OPEN CONTACTS ON EACH RELAY OPERATE AS FOLLOWS:
- COMPRESSOR — THE NO CONTACTS CLOSE WHEN COMPRESSOR STATUS FROM STARTER MODULE IS EITHER STARTING OR RUNNING.
 - ALARM RELAY — THE NO CONTACTS CLOSE WHEN THERE IS AN DIAGNOSTIC THAT HAS CAUSED A CHILLER SHUTDOWN WITH EITHER A MANUAL RESET REQUIRED OR AN AUTOMATIC RESET POTENTIAL.
 - CHILLER LIMIT MODE RELAY — THE NO CONTACTS CLOSE WHENEVER THE CHILLER HAS BEEN RUNNING IN ONE OF THE UNLOADING TYPES OF LIMIT MODES (CONDENSER, EVAPORATOR, CURRENT LIMIT OR PHASE IMBALANCE LIMIT) CONTINUOUSLY FOR THE LAST 20 MINUTES.
 - HEAD PRESSURE RELIEF — THE NO CONTACTS CLOSE ANYTIME THE CHILLER IS RUNNING IN ONE OF THE FOLLOWING MODES: ICE MAKING MODE OR CONDENSER PRESSURE LIMIT CONTROL MODE CONTINUOUSLY FOR THE DURATION SPECIFIED BY THE CHILLER HEAD RELIEF RELAY FILTER TIME.

30. WHEN ORDERED THE OUTDOOR AIR TEMP SENSOR ELECTRONICS IS FACTORY MOUNTED TO THE CONTROL PANEL AND THE IPC BUS IS FACTORY WIRED. THE SENSOR IS TO BE WIRED, RELOCATED EXTERNALLY WITH THE SENSOR LEADS EXTENDED BACK TO THE PANEL. THESE WIRES CAN BE SPLICED WITH TWO 14 - 18 AWG 600V WIRES, WITH MAXIMUM LENGTH OF 1000 FT (305 METERS). SPLICE AT SENSOR END MUST BE REFER TO UNIT IOM FOR DETAILS.

B

C

D

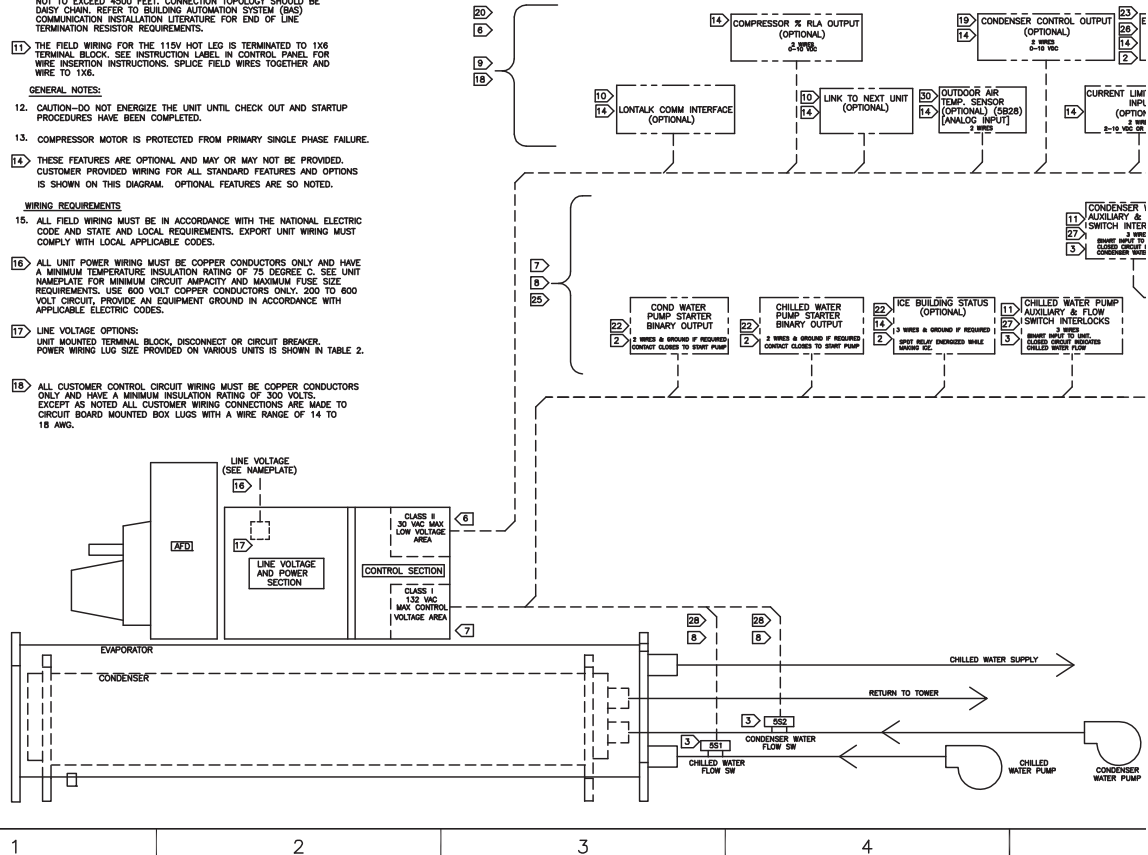

TRANE <small>THIS DRAWING IS PROPRIETARY AND SHALL NOT BE COPIED OR ITS CONTENTS DISCLOSED TO OUTSIDE PARTIES WITHOUT THE WRITTEN CONSENT OF TRANE</small> DRAWN BY: R. SPENCER © TRANE DATE: 14-MAY-2014	23110023 SHEET 1 OF 1 REV B
FIELD LAYOUT DIAGRAM RTHD VSD	
REPLACES: _____ REVISION DATE: _____ SIMILAR TO: _____	

PROVIDED INDICATORS MAY BE RELAYS, LIGHTS OR AUDIBLE DEVICES. INDICATION IS ASSOCIATED WITH A SPDT RELAY. THE INDICATORS MAY BE WIRING TO EITHER OR BOTH OF THE NORMALLY OPEN OR NORMALLY CLOSED RELAY CONTACTS OF EACH OF THE 4 SPOT RELAYS ON THE OPTIONAL RATING STATUS MODULE.

FUNCTIONS OF THE OPERATING STATUS MODULE RELAYS ARE PROGRAMMABLE. FOR DETAILS, DEFAULT FUNCTIONS ARE SHOWN.

ALL OPEN CONTACTS ON EACH RELAY OPERATE AS FOLLOWS:

STOP — THE NO CONTACTS CLOSE WHEN COMPRESSOR STATUS FROM STARTER MODULE IS EITHER STARTING OR RUNNING.

FAULT — THE NO CONTACTS CLOSE WHEN THERE IS AN DIAGNOSTIC THAT HAS CAUSED A CHILLER SHUTDOWN WITH EITHER A MANUAL RESET REQUIRED OR AN AUTOMATIC RESET POTENTIAL.

LIMIT — THE NO CONTACTS CLOSE WHENEVER THE CHILLER HAS BEEN RUNNING IN ONE OF THE UNLOADING TYPES OF LIMIT MODES (CONDENSER, EVAPORATOR, CURRENT LIMIT OR PHASE IMBALANCE LIMIT) CONTINUOUSLY FOR THE LAST 20 MINUTES.

OVERLOAD — THE NO CONTACTS CLOSE ANYTIME THE CHILLER IS RUNNING IN ONE OF THE FOLLOWING MODES: ICE MAKING MODE OR CONDENSER PRESSURE LIMIT CONTROL MODE CONTINUOUSLY FOR THE DURATION SPECIFIED BY THE CHILLER HEAD RELIEF RELAY FILTER TIME.

LOCATED THE OUTDOOR AIR TEMP SENSOR ELECTRONICS IS FACTORY MOUNTED INSIDE CONTROL PANEL AND THE IPC BUS IS FACTORY WIRED. THE SENSOR IS TO BE FIELD LOCATED EXTERNALLY WITH THE SENSOR LEADS EXTENDED BACK TO THE CONTROL PANEL. THESE WIRES CAN BE SPLICED WITH TWO 14 - 18 AWG 600V WIRES, WITH A LENGTH OF 1000 FT (305 METERS). SPLICE AT SENSOR END MUST BE WATER TIGHT. SEE UNIT IOM FOR DETAILS.

WARNING
 HAZARDOUS VOLTAGE!
 DISCONNECT ALL ELECTRIC POWER INCLUDING REMOTE DISCONNECTS AND FOLLOW LOCK-OUT AND TAG PROCEDURES BEFORE SERVICING. INSURE THAT ALL MOTOR CAPACITORS HAVE DISCHARGED STORED VOLTAGE. UNITS WITH VARIABLE SPEED DRIVE, REFER TO DRIVE INSTRUCTIONS FOR CAPACITOR DISCHARGE. FAILURE TO DO THE ABOVE BEFORE SERVICING COULD RESULT IN DEATH OR SERIOUS INJURY.

AVERTISSEMENT
 TENSION DANGEREUSE!
 COUPER TOUTES LES TENSIONS ET OUVRIR LES SECTIONNEURS A DISTANCE, PUIS SUIVRE LES PROCEDURES DE VERROUILLAGE ET DES ETIQUETTES AVANT TOUTE INTERVENTION. VÉRIFIER QUE TOUTS LES CONDENSATEURS DES MOTEURS SONT DÉCHARGÉS. DANS LE CAS D'UNITÉS COMPORTANT DES ENTRAÎNEMENTS À VITESSE VARIABLE, SE REPORTER AUX INSTRUCTIONS DE L'ENTRAÎNEMENT POUR DÉCHARGER LES CONDENSATEURS. NE PAS RESPECTER CES MESURES DE PRÉCAUTION PEUT ENTRAÎNER DES BLESSURES GRAVES POUVANT ÊTRE MORTELLES.

ADVERTENCIA
 VOLTAJE PELIGROSO!
 DESCONECTE TODA LA ENERGÍA ELÉCTRICA, INCLUIDO LAS DESCONEXIONES REMOTAS Y SIGA LOS PROCEDIMIENTOS DE CIERRE Y ETIQUETADO ANTES DE PROCEDER AL SERVICIO. ASEGURESE DE QUE TODOS LOS CAPACITORES DEL MOTOR HAYAN DESCARGADO EL VOLTAJE ALMACENADO. PARA LAS UNIDADES CON EJE DE DIRECCIÓN DE VELOCIDAD VARIABLE, CONSULTE LAS INSTRUCCIONES PARA LA DESCARGA DEL CONDENSADOR. EL NO REALIZAR LO ANTERIORMENTE INDICADO, PODRÍA OCASIONAR LA MUERTE O SERIAS LESIONES PERSONALES.

CAUTION
 USE COPPER CONDUCTORS ONLY!
 UNIT TERMINALS ARE NOT DESIGNED TO ACCEPT OTHER TYPES OF CONDUCTORS. FAILURE TO DO SO MAY CAUSE DAMAGE TO THE EQUIPMENT.

ATTENTION
 N'UTILISER QUE DES CONDUCTEURS EN CUIVRE!
 LES BORNES DE L'UNITÉ NE SONT PAS CONÇUES POUR RECEVOIR D'AUTRES TYPES DE CONDUCTEURS. L'UTILISATION DE TOUT AUTRE CONDUCTEUR PEUT ENDOMMAGER L'ÉQUIPEMENT.

PRECAUCIÓN
 ÚTILICE ÚNICAMENTE CONDUCTORES DE COBRE!
 LAS TERMINALES DE LA UNIDAD NO ESTÁN DISEÑADAS PARA ACEPTAR OTROS TIPOS DE CONDUCTORES. SI NO LO HACE, PUEDE OCASIONAR DAÑO AL EQUIPO.

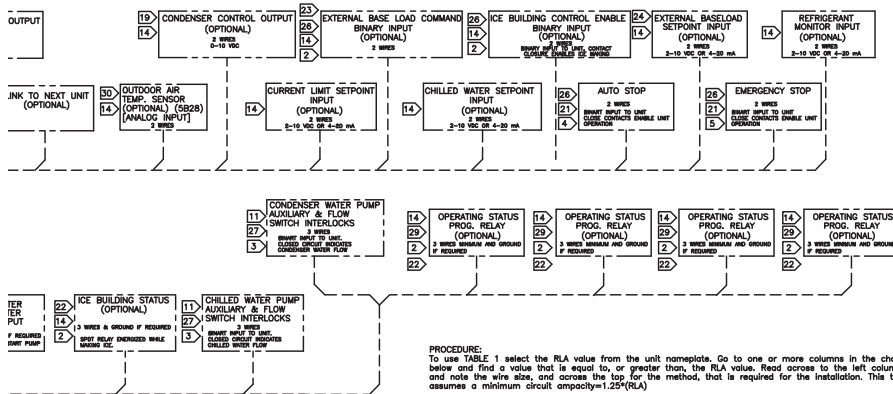

PROCEDURE:
 To use TABLE 1 select the RLA value from the unit nameplate. Go to one or more columns in the chart below and find a value that is equal to, or greater than, the RLA value. Read across to the left column and note the wire size, and across the top for the method that is required for the installation. This table assumes a minimum circuit ampacity=1.25*(RLA)

NOTE:
 This procedure will offer several options for providing electrical service to the starter panel. Before making a final selection, review the accompanying Table 2 indicating wire ranges for the available lug sizes supplied on the equipment.

MIN WIRE SIZE COPPER (AWG)	SUPPLY LEADS FOR ALL STARTER PANELS							
	1 CONDUIT 3 WIRE	1 CONDUIT 6 WIRE	1 CONDUIT 9 WIRE	2 CONDUIT 6 WIRE	2 CONDUIT 12 WIRE	3 CONDUIT 9 WIRE	4 CONDUIT 12 WIRE	1 WIRE/PH/CO
8	40	**	**	**	**	**	**	**
6	52	**	**	**	**	**	**	**
4	68	**	**	**	**	**	**	**
3	80	**	**	**	**	**	**	**
2	92	**	**	**	**	**	**	**
1	104	**	**	**	**	**	**	**
0	120	192	252	240	384	360	480	480
00	140	224	294	280	448	420	560	560
000	160	256	336	320	512	480	640	640
0000	184	294	368	368	588	552	736	736
250	204	328	428	408	653	612	818	818
300	228	365	479	456	730	684	912	912
350	248	397	521	496	794	744	992	992
400	268	429	563	536	858	804	1072	1072
500	304	486	638	608	973	912	1216	1216

TERMINAL BLOCK	SELECTION RLA	LUG SIZE (PER PHASE)
MAIN CIRCUIT BREAKER	0 - 598	(2) #4 - 500 MCM
	599 - 779	NA
	0 - 200	(1) 3/0 - 350 MCM
NON-FUSED DISCONNECT SWITCH	201 - 476	(2) 2/0 - 500 MCM
	477 - 640	(3) 3/0 - 500 MCM
	0 - 277	(1) #1 - 600 MCM
	278 - 397	(2) 2/0 - 500 MCM
	398 - 598	(3) 3/0 - 500 MCM

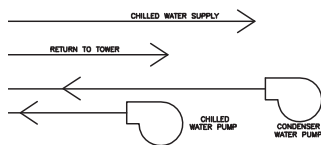

** Electrical conductors may be connected in parallel only for sizes 1/0 wire and larger per Nec 310-4. The unit nameplate will be marked 'Maximum Fuse or Circuit Breaker Size'. The maximum fuse or circuit breaker size is calculated as follows:
 Calculated value = 2.25 * (Compressor RLA)
 The calculated value is then used to select the fuse or circuit breaker from the standard sizes.
 Standard Sizes = 100, 110, 125, 150, 175, 200, 225, 300, 350, 400, 450, 500, 600, 700, 800, 1000, 1200, 1800, 2000.
 Maximum Fuse or Circuit Breaker Size = The standard size that is closest to the calculated value without exceeding it.

Dimensions and Weights

Unit Dimensions — Standard (Wye-Delta Starter)

Note: Dimensions are based on 3 Pass Evap/2 Pass Cond and LH/LH water connections.

Figure 1. BBB configuration

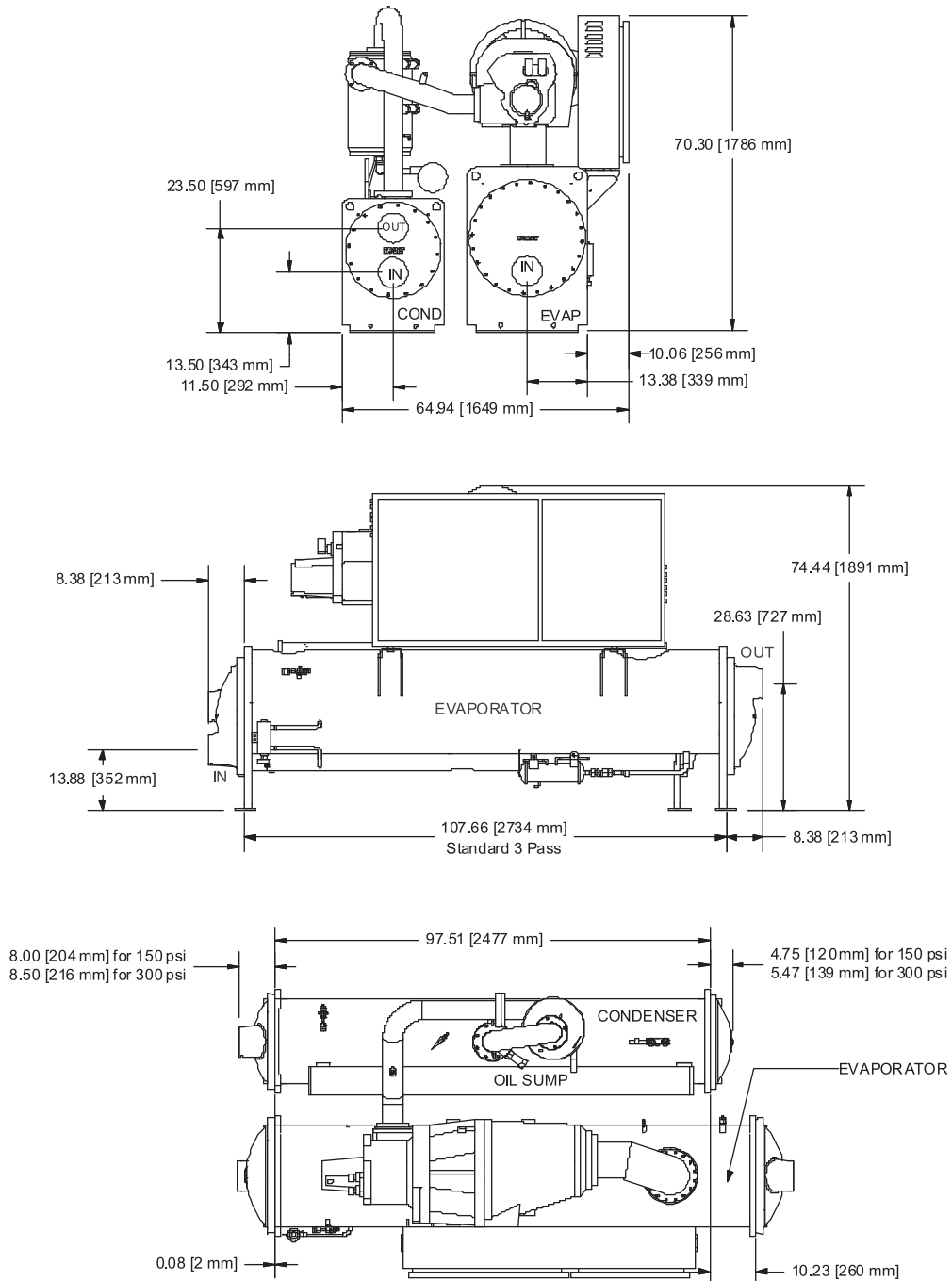
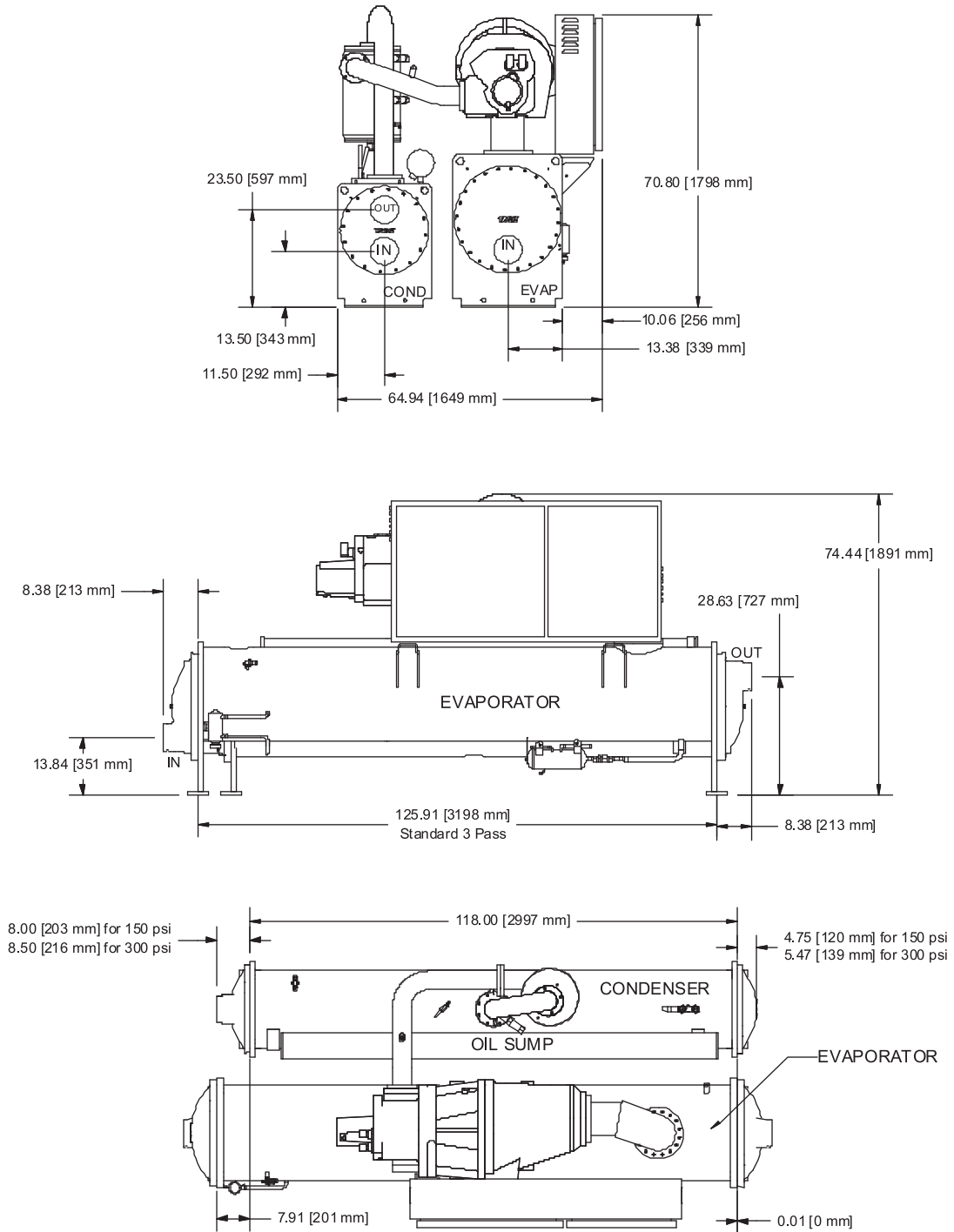

Figure 2. BCD configuration



Dimensions and Weights

Figure 3. CDE, DDE, EDE configurations

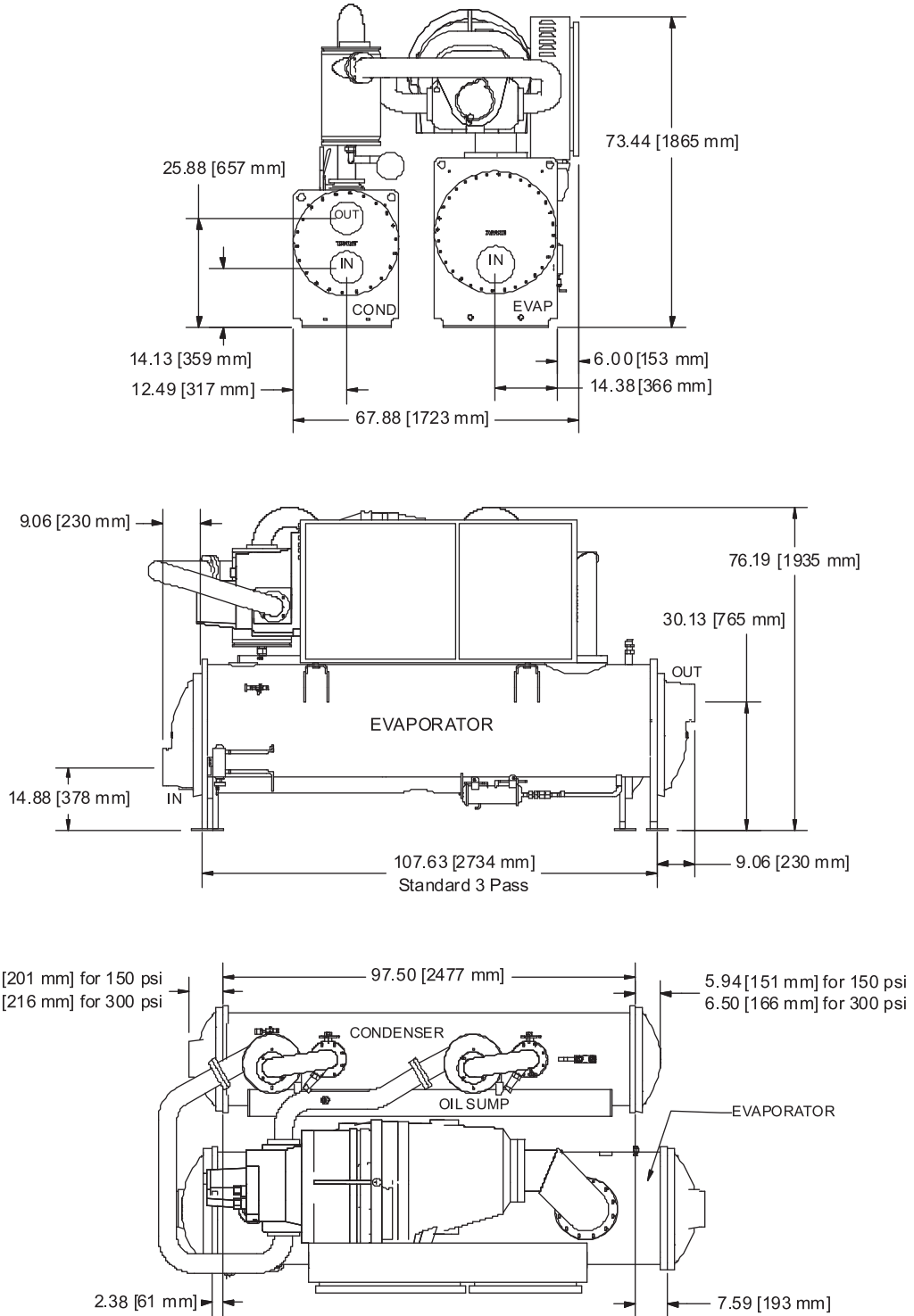
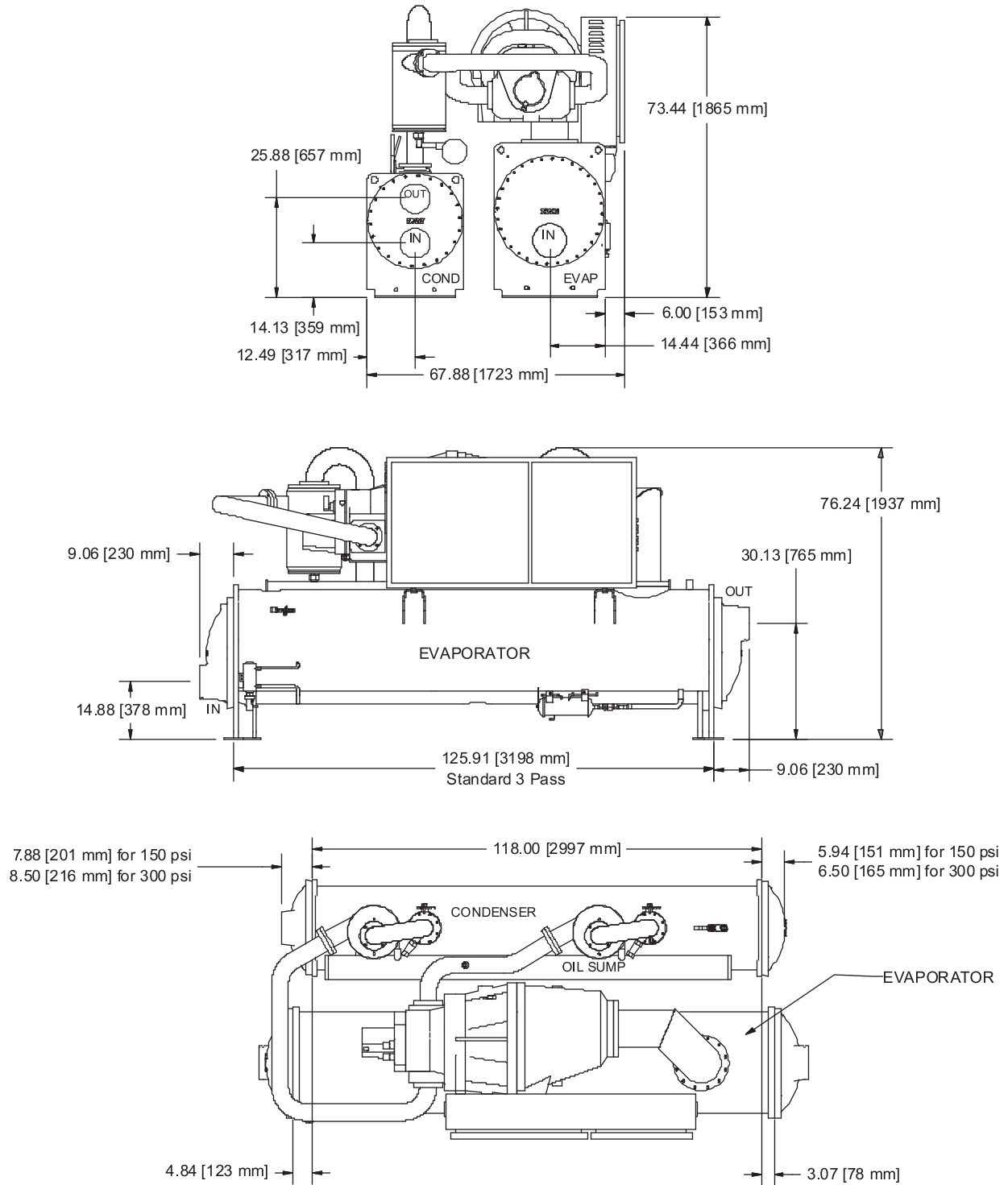

Figure 4. CEF configuration



Dimensions and Weights

Figure 5. CFF, DFF, EFF configurations

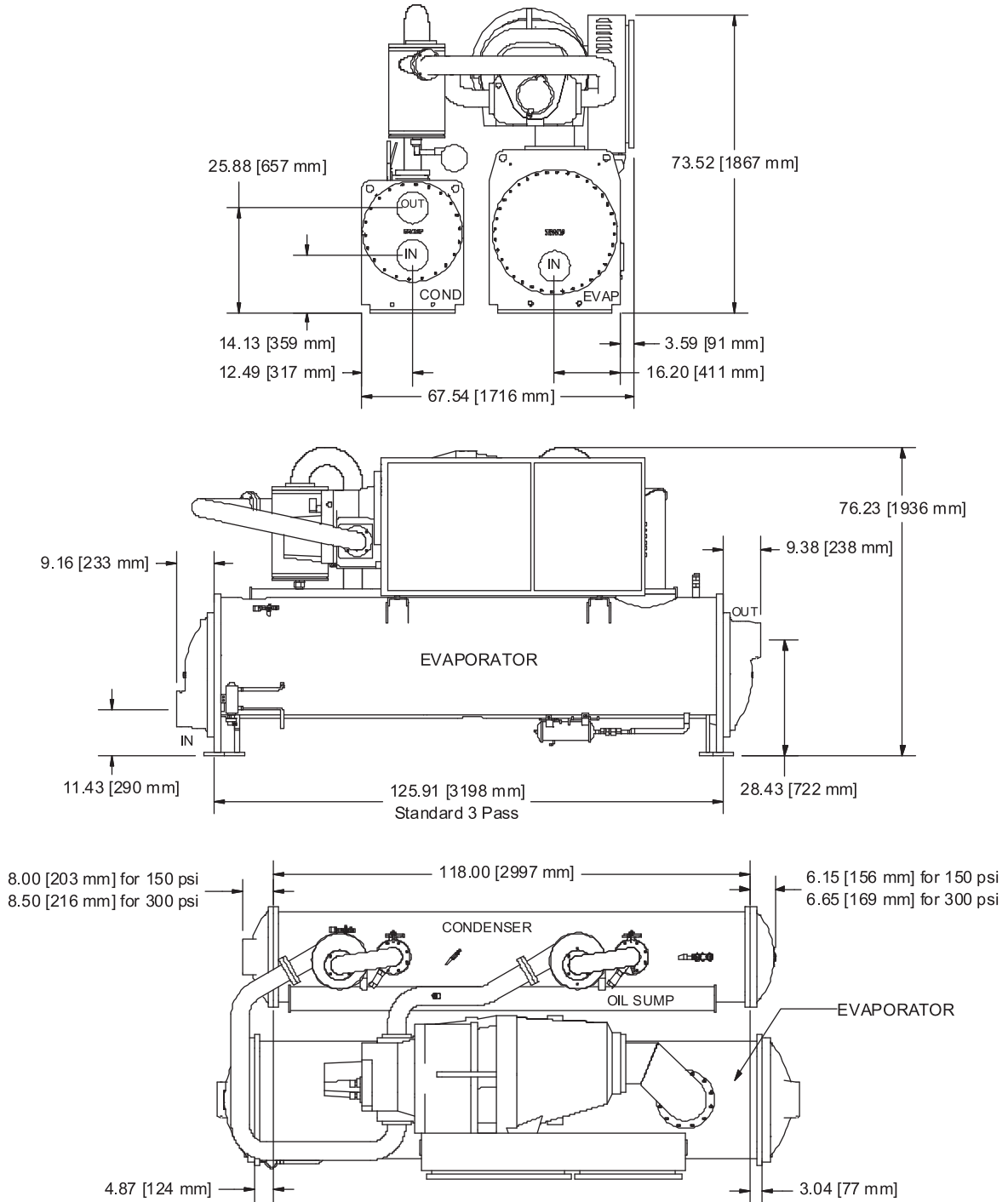
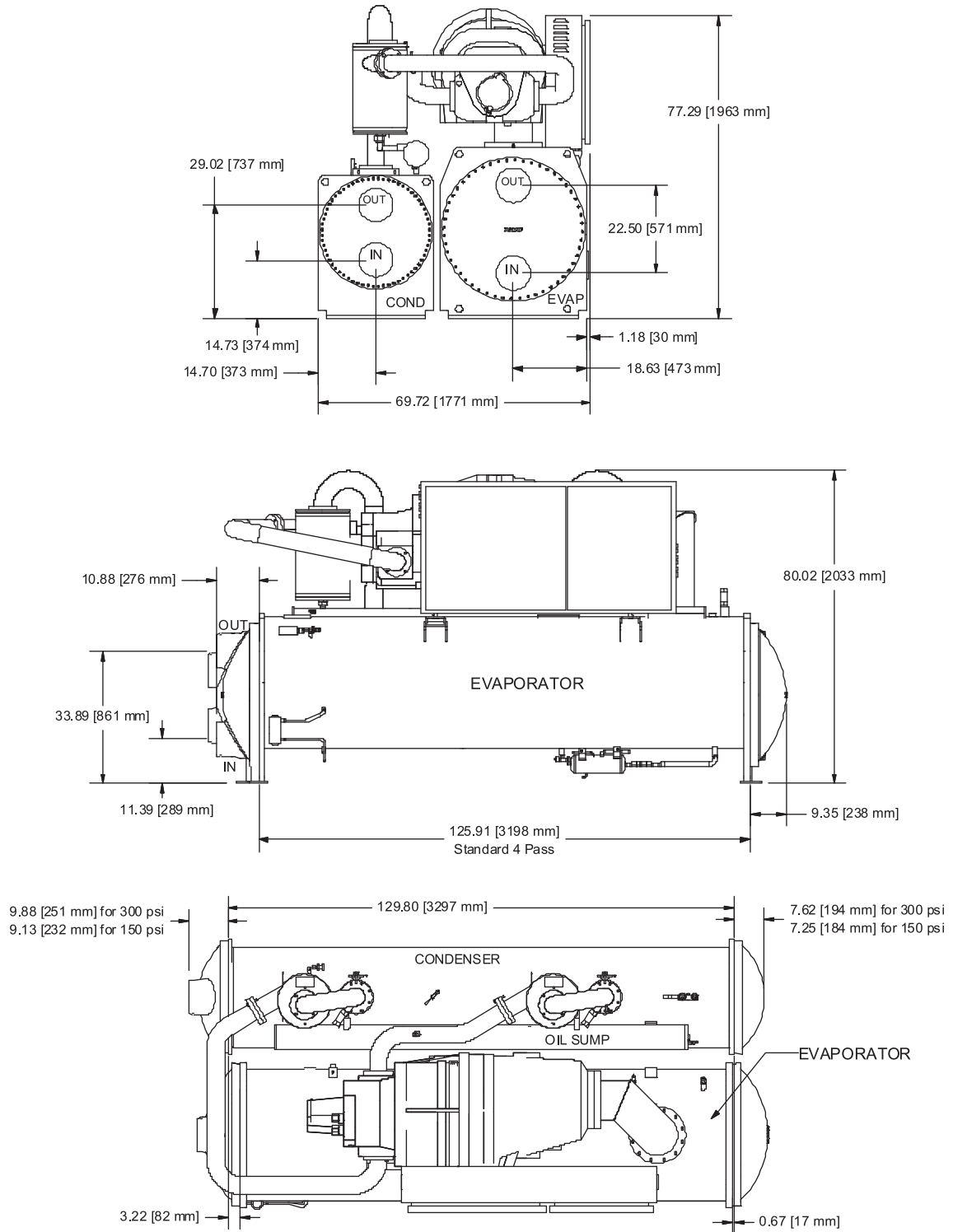

Figure 6. DGG, EGG configurations



Dimensions and Weights

Dimensions – Units with AFD Option

Note: Overall unit dimensions for units with the AFD option are shown in Table 15. All other dimensions are the same as standard unit dimensions specified in “Unit Dimensions - Standard (Wye-Delta Starter),” p. 32.

Figure 7. Overall unit dimensions - units with AFD option

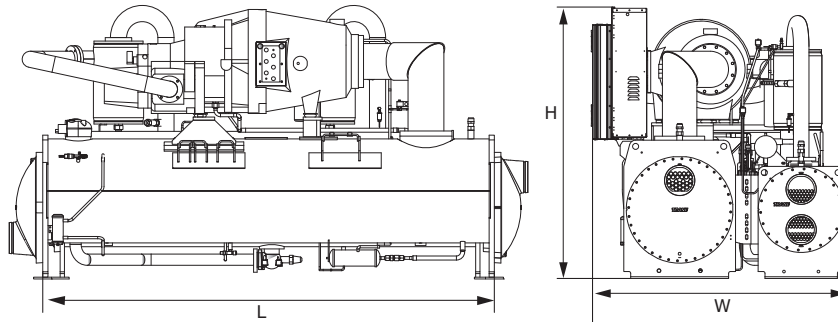

Table 15. Overall dimensions – units with AFD option^(a)

Unit Configuration ^(b)	AFD D1H Frame						AFD D2H Frame					
	Length (L)		Width (W)		Height (H)		Length (L)		Width (W)		Height (H)	
	in	mm	in	mm	in	mm	in	mm	in	mm	in	mm
B1B1B1	107.6	2734	71.3	1811	75.6	1920	107.6	2733	71.3	1811	80.8	2052
B1C1D1	125.9	3198	71.3	1811	75.6	1920	125.9	3198	71.3	1811	80.8	2052
B2B2B2	107.6	2734	71.3	1811	75.6	1920	107.6	2733	71.3	1811	80.8	2052
B2C2D2	125.9	3198	71.3	1811	75.6	1920	125.9	3198	71.3	1811	80.8	2052
C1D5E4	107.6	2734	74.5	1893	78.3	1989	107.6	2734	74.5	1893	83.5	2121
C1D6E5	107.6	2734	74.5	1893	78.3	1989	107.6	2734	74.5	1893	83.5	2121
C1E1F1	125.9	3198	74.4	1891	78.3	1989	125.9	3198	74.4	1891	83.5	2121
C2D3E3	107.6	2734	74.5	1893	78.3	1989	107.6	2734	74.5	1893	83.5	2121
C2D4E4	107.6	2734	74.5	1893	78.3	1989	107.6	2734	74.5	1893	83.5	2121
C2F2F3	125.9	3198	74.2	1886	78.7	1999	125.9	3198	74.2	1886	84.3	2141
D1D1E1	-	-	-	-	-	-	107.6	2734	74.5	1893	83.5	2121
D1F1F2	-	-	-	-	-	-	125.9	3198	74.2	1885.7	84.3	2141
D1G1G1	-	-	-	-	-	-	129.5	3289	76.7	1948	87.3	2217
D1G2G2	-	-	-	-	-	-	129.5	3289	76.7	1948	87.3	2217
D2D2E2	-	-	-	-	-	-	107.6	2734	74.5	1893	83.5	2121
D2F2F3	-	-	-	-	-	-	125.9	3198	74.2	1886	84.3	2141
D2G2G1	-	-	-	-	-	-	129.5	3289	76.7	1948	87.3	2217
D2G3G3	-	-	-	-	-	-	129.5	3289	76.7	1948	87.3	2217
D3D2E2	-	-	-	-	-	-	107.6	2734	74.5	1893	83.5	2121
D3F2F3	-	-	-	-	-	-	125.9	3198	74.2	1886	84.3	2141
D3G2G1	-	-	-	-	-	-	129.5	3289	76.7	1948	87.3	2217
E3D2E2	-	-	-	-	-	-	107.6	2734	74.5	1893	83.5	2121
E3F2F3	-	-	-	-	-	-	125.9	3198	74.2	1886	84.3	2141
E3G2G1	-	-	-	-	-	-	129.5	3289	76.7	1948	87.3	2217
E3G3G3	-	-	-	-	-	-	129.5	3289	76.7	1948	87.3	2217

(a) Dimensions vary with AFD frame size. D1H frame size used on units with model number digit 44 = V, W, X, 2, 3, 4, G, H or J. D2H frame size used with model number digit 44 = Y, Z, 1, 5, 6, 7, K, L, M or N.

(b) Unit configuration digits 1, 2 - compressor code (also shown in unit model number digits 6, 7); digits 3, 4 - evaporator code (unit model number digits 14, 15); digits 5, 6 - condenser code (unit model number digits 21, 22).

Service Clearances

Table 16. Service clearances

Unit Configuration ^(a)	Recommended Clearance									
	Front		Back		Either end		Other End ^(b)		Top	
	in	mm	in	mm	in	mm	in	mm	in	mm
BBB, CDE, DDE, EDE	36	914	36	914	36	914	108	2743	36	914
BCD, CEF, CFF, DFF, EFF, DGG, EGG	36	914	36	914	36	914	126	3200	36	914

(a) Unit configuration digit 1 - compressor code (shown in unit model number digit 6); digit 2 - evaporator code (model number digit 14); digit 3 - condenser code (model number digit 21).

(b) Clearance for tube removal



Dimensions and Weights

Weights

Table 17. Weights — standard units (wye-delta starter)

Unit Configuration ^(a)	Shipping Weight		Operating Weight	
	lbs	kg	lbs	kg
B1B1B1	9,292	4,215	9,867	4,476
B1C1D1	9,837	4,462	10,554	4,787
B2B2B2	9,402	4,265	10,019	4,545
B2C2D2	9,953	4,515	10,653	4,832
C1D5E4	12,973	5,884	13,673	6,202
C1D6E5	12,780	5,797	13,397	6,077
C1E1F1	14,718	6,676	15,818	7,175
C2D3E3	14,002	6,351	15,044	6,824
C2D4E4	12,972	5,884	13,672	6,201
C2F2F3	16,168	7,334	17,560	7,965
D1D1E1	14,443	6,551	15,385	6,987
D1F1F2	16,187	7,342	17,537	7,955
D1G1G1	18,600	8,437	20,500	9,299
D1G2G2	19,107	8,667	21,065	9,555
D2D2E2	14,562	6,605	15,570	7,062
D2F2F3	16,820	7,629	18,220	8,264
D2G2G1	18,700	8,482	20,700	9,389
D2G3G3	19,508	8,849	21,641	9,816
D3D2E2	14,562	6,605	15,570	7,062
D3F2F3	16,820	7,629	18,220	8,264
D3G2G1	18,650	8,460	20,650	9,367
E3D2E2	14,720	6,677	15,728	7,134
E3F2F3	16,956	7,691	18,356	8,326
E3G2G1	18,800	8,528	20,800	9,435
E3G3G3	19,653	8,915	21,786	9,882

Notes:

1. All weights +/- 3%
2. Shipping weights include standard 150 psig water boxes, refrigerant charge and oil charge.
3. Operating weights include refrigerant, oil and water charges.

(a) Unit configuration digits 1, 2 - compressor code (also shown in unit model number digits 6, 7); digits 3, 4 - evaporator code (unit model number digits 14, 15); digits 5, 6 - condenser code (unit model number digits 21, 22).

Table 18. Weights — units with AFD option^(a)

Unit Configuration ^(b)	Shipping Weight				Operating Weight			
	AFD D1H Frame		AFD D2H Frame		AFD D1H Frame		AFD D2H Frame	
	lbs	kg	lbs	kg	lbs	kg	lbs	kg
B1B1B1	9526	4321	9664	4384	10101	4582	10239	4645
B1C1D1	10071	4568	10209	4631	10787	4893	10925	4956
B2B2B2	9636	4371	9774	4434	10251	4650	10389	4713
B2C2D2	10187	4621	10325	4684	10886	4938	11024	5001
C1D5E4	13206	5990	13344	6053	13904	6307	14043	6370
C1D6E5	13014	5903	13153	5966	13631	6183	13770	6246
C1E1F1	14949	6781	15088	6844	16801	7621	16940	7684
C2D3E3	14235	6457	14374	6520	15278	6930	15417	6993
C2D4E4	13206	5990	13344	6053	13907	6308	14046	6371
C2F2F3	17055	7736	17194	7799	18446	8367	18585	8430
D1D1E1	-	-	14815	6720	-	-	15756	7147
D1F1F2	-	-	16559	7511	-	-	17910	8124
D1G1G1	-	-	18973	8606	-	-	20873	9468
D1G2G2	-	-	19480	8836	-	-	21438	9724
D2D2E2	-	-	14934	6774	-	-	15944	7232
D2F2F3	-	-	17194	7799	-	-	18594	8434
D2G2G1	-	-	19072	8651	-	-	21074	9559
D2G3G3	-	-	19881	9018	-	-	22013	9985
D3D2E2	-	-	14934	6774	-	-	15944	7232
D3F2F3	-	-	17194	7799	-	-	18594	8434
D3G2G1	-	-	19023	8629	-	-	21023	9536
E3D2E2	-	-	15093	6846	-	-	16100	7303
E3F2F3	-	-	17337	7864	-	-	18728	8495
E3G2G1	-	-	19173	8697	-	-	21173	9604
E3G3G3	-	-	20036	9088	-	-	22169	10056

Notes:

1. All weights +/- 3%
2. Shipping weights include standard 150 psig water boxes, refrigerant charge and oil charge.
3. Operating weights include refrigerant, oil and water charges.
4. AFD frame size determined by unit selection. See submittal for information.

(a) Weights vary with AFD frame size. D1H frame size used on units with model number digit 44 = G, H, J, V, W, X, 2, 3, or 4. D2H frame size used with model number digit 44 = K, L, M, N, Y, Z, 1, 5, 6, or 7.

(b) Unit configuration digits 1, 2 - compressor code (also shown in unit model number digits 6, 7); digits 3, 4 - evaporator code (unit model number digits 14, 15); digits 5, 6 - condenser code (unit model number digits 21, 22).



Mechanical Specifications

General

Exposed metal surfaces are painted with air-dry beige, direct-to-metal, single-component paint. Each unit ships with full operating charges of refrigerant and oil. Molded elastomeric isolation pads are supplied for placement under all support points.

Compressor and Motor

Unit is equipped with a semi-hermetic, direct-drive, 3600 rpm 60 Hz (3000 rpm 50 Hz) rotary compressors that includes a capacity control slide valve, oil sump heater, and differential pressure refrigerant oil flow system. Four pressure-lubricated rolling element bearing groups support the rotary assembly. Motor is suction gas-cooled, hermetically sealed, two-pole squirrel cage induction motor.

Unit-Mounted Starter

The unit is supplied with a UL 1995 indoor type enclosure with top power-wiring access and three-phase, solid-state overload protection. The starter is factory-mounted and fully pre-wired to the compressor motor and control panel. A factory-installed, factory-wired 600 VA control power transformer provides all unit control power (120 Vac secondary) and UC800 module power (24 Vac secondary). Optional power line connections include circuit breaker, high fault panel with circuit breaker, or mechanical, non-fused disconnect.

Evaporator and Condenser

Heat exchangers are shell and tube design. Standard tubes are externally finned, internally enhanced seamless copper with lands at all tube sheets. All tube sheets are made of carbon steel. Tubes are mechanically expanded into tube sheets and mechanically fastened to tube supports. Evaporator tubes are 1.0- inch (25.4 mm) diameter and condenser tubes are 0.75-inch (19.05 mm) diameter. All tubes can be individually replaced.

Shells are carbon steel plate. The evaporator and condenser are designed, tested, and stamped in accordance with ASME Code for refrigerant-side/ working-side pressure of 200 psig (13.8 bars).

All water pass arrangements are available with grooved connections (150 or 300 psig waterside working pressure). All connections may be either right- or left-handed. Waterside shall be hydrostatically tested at 1.5X design working pressure.

Refrigerant Circuit

Each unit has a single refrigerant circuit. Each refrigerant circuit includes compressor suction and discharge service valves, removable core filter, charging port, and sight glass. An electronically controlled expansion valve is provided to maintain variable capacity modulation over the entire building load and maintain proper refrigerant flow.

Oil Management

The unit is configured with an oil management system that ensures proper oil circulation throughout the unit. The key components of the system include an oil separator, oil filter, oil sump and oil sump heater. An optional oil cooler is installed when the unit is used for high condensing temperature or low evaporator temperature conditions.

Tracer AdaptiView™ TD7 Display

The Tracer AdaptiView™ TD7 is a 7" diagonal 16 bit graphic color display with 800x480 pixels and TFT LCD @ 600 nits brightness. The display provides alarms, reports, settings as well as graphing. The display supports 26 languages and complies with the following standards: IP56, RoHS, UL 916, CE, EN55011 (class B), and EN61000 (Industrial).

Unit Controls

All controls, including sensors, are factory mounted and tested prior to shipment. Microcomputer controls provide all control functions including startup and shut down, leaving chilled water temperature control, evaporator flow proving, compressor staging and speed control, electronic expansion valve modulation, anti-recycle logic, automatic lead/lag compressor starting and load limiting.

The Tracer® UC800 unit control module, utilizing Adaptive Control™ microprocessor, automatically takes action to avoid unit shut-down due to abnormal operating conditions associated with low refrigerant pressure, high condensing pressure, AFD/Compressor current overload, low oil return or low AFD cooling, low discharge superheat, and high compressor discharge temperature. Should the abnormal operating condition continue until a protective limit is violated, the unit will be shut down. Unit protective functions of the UC800, include loss of chilled water flow, evaporator freezing, loss of refrigerant, low refrigerant pressure, high refrigerant pressure, high compressor motor temperature, and loss of oil to the compressor.

A full color Tracer AdaptiView™ TD7 touch screen display indicates all important unit and circuit parameters, in logical groupings on various screens. The parameters including chilled water set point, leaving chilled water temperature, demand limit set point, evaporator and condenser refrigerant temperatures and pressures, compressor speeds, and all pertinent electrical information. The display also provides "on screen" trending graphs of predefined parameters as well as customizable trend graphs based on user defined parameters from a list of all available parameters. The display also provides indication of the chiller and circuits' top level operating modes with detailed sub-mode reports available with a single key press, as well as diagnostics annunciation and date and time stamped diagnostic history.

Standard power connections include main three phase power to the compressors, control power transformer and optional connections are available for the 115 volt/60 Hz single phase power for the thermostatically controlled evaporator heaters for freeze protection.

Quality Assurance

The quality management system applied by Trane has been subject to independent third-party assessment and approval to ISO 9001. The products described in this catalog are designed, manufactured and tested in accordance with the approved system requirements described in the Trane Quality Manual.



Mechanical Specifications

Options

Electrical Options

Adaptive Frequency Drive

Trane's Adaptive Frequency™ Drive (AFD) technology for controlling the compressors is available as an option on RTHD chillers. AFD is a family of adaptive frequency drives specifically designed for Trane water chillers. AFD incorporates the Trane communication protocol enabling seamless integration with the unit controller. AFD data such as drive status, temperatures, modes and diagnostic information are accessible to the unit controller and through the Tracer®TU service tool.

AFD contains technology that enables the drive to last the life time of the chiller and with less down time. The technology enables operation on various power systems including alternative energy sources. AFD will protect itself and the compressor motor from over current, low or high line voltage, phase loss, incoming phase imbalance, and over temperature due to loss of drive cooling or loss of panel ventilation.

AFD incorporates improved serviceability and troubleshooting tools to identify the issue quickly and get the chiller back up and running. All AFD control circuits are powered with class 2 low voltage — separate from main power allowing service on the controls with the panel door open. Additionally, the main electronic control modules can be serviced with the standard Trane screw driver. The AFD further incorporates another Trane service tool to allow for firmware upgrades through Tracer TU.

Wye-Delta Starter

This option provides a reduced-inrush, unit mounted starter with a UL 1995 enclosure.

Circuit Breaker

A molded case standard interrupting capacity circuit breaker, factory pre-wired with terminal block power connections and equipped with a lockable external operator handle, is available to disconnect the chiller from main power.

High Interrupting Capacity Circuit Breaker

A molded case high interrupting circuit breaker, factory pre-wired with terminal block power connections and equipped with a lockable external operator handle, is available to disconnect the chiller from main power. The panel has a higher short circuit rating as determined by UL 1995.

Non-Fused Disconnect

A non-fused molded case disconnect switch, factory pre-wired with terminal block power connections and equipped with a lockable external operator handle, is available to disconnect the chiller from main power.

Under/Over-Voltage Protection

Unit receives protection against variations in voltage (current lag and spike protection is standard).

Control Options

BACnet® Interface

Allows the user to easily interface with BACnet® via a single twisted pair wiring to a factory installed and tested communication board.

LonTalk® Interface

Provides the LonMark® chiller profile inputs/outputs for use with a generic building automation system via a single twisted pair wiring to a factory installed and tested communication board.

Modbus™ Interface

Tracer AdaptiView™ control can be configured for Modbus™ communications at the factory or in the field. This enables the chiller controller to communicate as a slave device on a Modbus™ network. Chiller setpoints, operating modes, alarms, and status can be monitored and controlled by a Modbus™ master device.

Chilled Water Reset – Outdoor Air Temperature

Controls, sensors, and safeties allow reset of chilled water temperature, based on temperature signal, during periods of low outdoor air temperature (chilled water reset based on return chilled water temperature is standard).

Condenser Leaving Water Temperature Control

Enables the unit to use the leaving condenser water temperature to load and unload the chiller relative to the leaving condenser water setpoint. The control system allows for a condenser leaving temperature range up to 114°F (45.56°C).

Condenser Pressure Output

Provides a 0–10 Vdc signal based on the system refrigerant differential or condenser pressure.

Condenser Regulating Valve Control Output

Provides a PID algorithm to control a condenser water regulating valve via 0-10 Vdc signal.

External Base Loading

External base loading is communicated to a factory-installed, tested communication board through a 2–10 Vdc or 4–20 mA signal.

External Chilled Water or Hot Water Setpoint

External chilled or hot water setpoint signal can be field wired to a factory-installed, tested interface board through a 2–10 Vdc or 4–20 mA signal.

External Current Limiting

External current limiting is communicated to a factory-installed, tested interface board through a 2–10 Vdc or 4–20 mA signal.

Ice Making Control

Controls and safeties allow operation with brine down to 20°F (-6.7°C), and dual setpoints enable both ice making and daytime comfort cooling.

Programmable Relays

Predefined, factory-installed, programmable relays allow the operator to select four relay outputs. Available outputs are: Alarm-Latching, Alarm-Auto Reset, General Alarm, Warning, Chiller Limit Mode, Compressor Running, Head Pressure Relief Request, and Tracer Control.



Mechanical Specifications

Refrigerant Monitor Input

Control system indicates refrigerant monitor status of 0-100 or 0-1000 ppm (user selectable), based on a 2-10 Vdc or 4-20 mA signal.

Other Options

Condenser Copper Tubes

Externally fined and internally enhanced copper tubes are available with 0.025" or 0.028"

Flow Switches - Field Installed

NEMA 1 or NEMA 4 flow switches with 150 psi or 300 psi ship with the unit.

Insulation

The evaporator, water boxes, suction line, and motor housing are covered with factory installed 0.75 inch (19.05 mm) insulation. Factory installed foam insulation is used on the liquid level sensor and gas pump assembly (with its associated piping).

Nitrogen Charge

Unit is shipped with a nitrogen holding charge in lieu of refrigerant.

Performance and Witness Tests

Performance and witness tests are conducted based on requested operating points, to certify chiller performance.

Refrigerant Isolation Valves

Factory-installed condenser inlet and outlet refrigerant valves allow isolation of the full refrigerant charge in the condenser while servicing the chiller.

Seal Kit for Reassembly

Ideal for situations when the bolt-together construction of the RTHD will be separated for installation, this seal kit provides replacement gaskets and rings for reassembly.

Two-Way Condenser Water Regulating Valve

For water regulation, a field-installed, 2-way butterfly-type (lug-style) valve, with integral electrical operator and factory-mounted valve actuator, is available. The single-phase, dual frequency (50 or 60 Hz) motor can be selected with 115 V (can be powered directly from control power transformer at unit) or 220 V power. The 2-way valve is field-wired and controlled by the chiller regulating valve control output. Valves are available in 6 and 8 inch (152.4 mm and 203.2 mm) sizes.

Water Boxes - 300 psig

Water boxes for the evaporator and condenser are designed for 300 psig maximum waterside working pressure, and grooved pipe water connection are provided for ease of installation.



Globally Recognized. Industry Respected.



Ingersoll Rand (NYSE:IR) advances the quality of life by creating comfortable, sustainable and efficient environments. Our people and our family of brands—including Club Car®, Ingersoll Rand®, Thermo King® and Trane®—work together to enhance the quality and comfort of air in homes and buildings; transport and protect food and perishables; and increase industrial productivity and efficiency. We are a global business committed to a world of sustainable progress and enduring results. For more information, visit www.ingersollrand.com.

Ingersoll Rand has a policy of continuous product and product data improvement and reserves the right to change design and specifications without notice. The AHRI Certified mark indicates Ingersoll Rand's participation in the AHRI Certification program. For verification of individual certified products, go to www.ahrirectory.org.

© 2016 Ingersoll Rand All rights reserved
RLC-PRC020H-EN 31 Aug 2016
Supersedes RLC-PRC020G-EN (25 Aug 2015)

We are committed to using environmentally
conscious print practices that reduce waste.

