



TRANE®

Catalog

Split System Condensing Units and Remote Chiller Evaporators

20 to 120 Tons

50 and 60 Hz — R-410A





Introduction

Trane 20 to 120-ton air-cooled condensing units are the leaders in the split system marketplace. Designed for efficiency, reliability and flexibility, the Trane units have the most advanced design in the industry.

Twenty to 120-ton units feature the Trane 3-D™ Scroll compressor, solid-state controls and Trane's exclusive Packed Stock Plus availability 20 to 60 tons for quick shipment. These innovations make an already proven product even better!



Table of Contents

- Definitions of Abbreviations 4
- Features and Benefits 5
- Application Considerations 8
- Selection Procedure 11
- Model Number Descriptions 12
- General Data 13
- Performance Data 15
- Controls 28
- Electrical Data 29
- Dimensional Data 32
- Weights 51
- Mechanical Specifications 53
- 55



Definitions of Abbreviations

AL	Aluminum
ASTM	American Society of Testing and Materials
CFM	Cubic Feet Per Minute
Conn.	Connection
CSA	Canadian Standards Association
CU	Copper
DIA.	Diameter
dt	Temperature Difference
EER	Energy Efficiency Ratio (Btu/Watt-Hour)
(F)	Units of Temperature in Degrees Fahrenheit
ID	Inside Diameter
IEER	Integrated Energy Efficiency Ratio
(INT)	Internal
ITD	Initial Temperature Difference
k	Thermal Conductivity
KO	Knock Out
KW	Kilowatt (Unit of Power)
lbs.	Pounds (Unit of Weight)
Loc.	Location
LRA	Locked Rotor Amps
(MBH)	1 x 1000 Btuh
MTG.	Mounting
NPS	Nominal Pipe Size
OD	Outside Diameter
RLA	Rated Load Amps
SST	Saturated Suction Temperature
UL	Underwriters Laboratories Inc.
VAV	Variable Air Volume
W/	With
W/O	Without
XL	Across-the-Line-Start

Features and Benefits

Trane 3-D Scroll Compressor

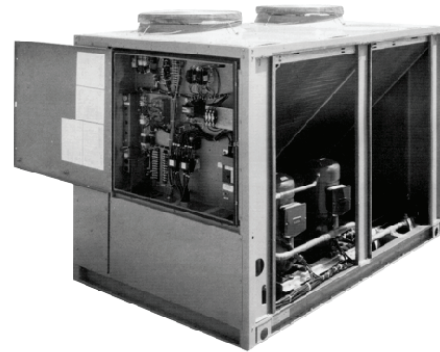
Simple Design with 70% Fewer Parts

Fewer parts than an equal capacity reciprocating compressor means significant reliability and efficiency benefits. The single orbiting scroll eliminates the need for pistons, connecting rods, wrist pins and valves. Fewer parts lead to increased reliability. Fewer moving parts, less rotating mass and less internal friction means greater efficiency than reciprocating compressors.

The Trane 3-D Scroll provides important reliability and efficiency benefits. The 3-D Scroll allows the orbiting scrolls to touch in all three dimensions, forming a completely enclosed compression chamber which leads to increased efficiency. In addition, the orbiting scrolls only touch with enough force to create a seal; there is no wear between the scroll plates. The fixed and orbiting scrolls are made of high strength cast iron which results in less thermal distortion, less leakage, and higher efficiencies. The most outstanding feature of the 3-D Scroll compressor is that slugging will not cause failure. In a reciprocating compressor, however, the liquid or dirt can cause serious damage.

Low Torque Variation

The 3-D Scroll compressor has a very smooth compression cycle; torque variations are only 30 percent of that produced by a reciprocating compressor. This means that the scroll compressor imposes very little stress on the motor resulting in greater reliability. Low torque variation reduces noise and vibration



Suction Gas Cooled Motor

Compressor motor efficiency and reliability is further optimized with the latest scroll design. Cool suction gas keeps the motor cooler for longer life and better efficiency.

Proven Design Through Testing and Research

With over twenty years of development and testing, Trane 3-D Scroll compressors have undergone more than 400,000 hours of laboratory testing and field operation. This work combined with over 25 patents makes Trane the worldwide leader in air conditioning scroll compressor technology.

Voltage Power Supply

20 to 120-ton units have four voltage options in 200, 230, 460 and 575.

Passive Manifolding

Trane offers a parallel manifolding scheme that uses no moving mechanical parts. This feature assures continuous oil return, again providing greater system reliability. And greater reliability means optimal performance over the life of the unit.

System Control Options

Trane offers three system control options on 20 to 60-ton units and two system control options on the 80 to 120-ton units, each using solid-state electronics. These options allow the unit to be ordered only with the controls needed. In addition, they come factory installed, saving field installation costs.



Features and Benefits

Coil Frost Protection

Trane offers FROSTAT™ with the VAV system control option on the 20 to 120-ton units. FROSTAT is the industry's most reliable method of coil frost protection and assures that your system will provide energy efficient comfort at part load conditions.

Remote Chiller Evaporator Option with Field Installation Kit

The remote chiller option includes a brazed plate heat exchanger with field installation kit, and requires the EVP control option for chilled water control.

The field installation kit includes evaporator mounting hardware and insulation, water piping stubs, and water flow switch.

20 to 120-Ton Units

Standard Features

- Trane 3-D™ Scroll compressors
- Phase Loss/Reversal/Low Voltage Monitor
- Factory-installed Discharge and Liquid Line Service Valves
- Passive manifolding for 3-D Scroll compressors
- Standard ambient operating range 40°F to 125°F (115°F max ambient for EVP chiller)
- Heavy gauge galvanized steel frame
- Louvered panels for coil protection
- Slate gray air-dry paint finish (exceeds 672 hour salt spray test in accordance with ASTM B117)

Optional Features

- Remote chiller evaporator with field installation kit
- Non-fused disconnect (20 to 60-Ton Models)
- Low ambient option
- Hot gas bypass to the evaporator inlet
- Suction service valve
- Pressure gauges
- Return air sensor
- Copper finned condenser coil
- Unit spring isolators
- Neoprene-in-shear isolators
- cULus approval (not available for 50 Hz)
- Packed Stock Plus program (20 to 60-Ton Models)
- Extended Compressor Warranty
- Special coil coating for corrosion resistance
- Constant volume, VAV, and no controls options on 20 to 60-Ton Models, VAV and no controls options on 80 to 120-Ton Models

Packed Stock Plus

Trane 20 to 60-ton air-cooled condensing units are available through the most flexible packed stock program in the industry. Trane knows that you want your units on the job site, on time, with the options you need.

Features and Benefits

Packed Stock Plus provides you with the controls and options you need — options like hot gas bypass, isolators and refrigerant gauges. You no longer have to settle for a basic unit requiring many field installed options to meet your job schedule. Now, you can get a customized unit from the factory in record time. The Packed Stock Plus program provides more control over unit selection and scheduling than ever before. Trane wants to make it easy for you to do business with them.



Application Considerations

Certain application constraints should be considered when sizing, selecting and installing Trane air-cooled condensing units. Unit reliability is dependent upon these considerations. Where your application varies from the guidelines presented, it should be reviewed with the local Trane sales engineer.

Unit Sizing

Unit capacities are listed in the performance data section. Intentionally oversizing a unit to assure adequate capacity is not recommended. Erratic system operation and excessive compressor cycling are often a direct result of an oversized condensing unit. In addition, an oversized unit is usually more expensive to purchase, install and operate. If oversizing is desired, consider using two units.

Unit Placement

A base or foundation is not required if the selected unit location is level and strong enough to support the unit's operating weight.

Isolation and Sound Emission

The most effective form of isolation is to locate the unit away from any sound sensitive area. Structurally transmitted sound can be reduced by using spring or rubber isolators. The isolators are effective in reducing the low frequency sound generated by compressors and, therefore, are recommended for sound sensitive installations. An acoustical engineer should always be consulted on critical applications.

For maximum isolation effect, the refrigeration lines and electrical conduit should also be isolated. Use flexible electrical conduit. State and local codes on sound emissions should always be considered. Since the environment in which a sound source is located affects sound pressure, unit placement must be carefully evaluated.

Servicing

Adequate clearance for compressor servicing should be provided. Recommended minimum space envelopes for servicing are located in the dimensional data section of this catalog and can serve as guidelines for providing adequate clearance. The minimum space envelopes also allow for control panel door swing and routine maintenance requirements. Local code requirements may take precedence.

Unit Location

Unobstructed flow of condenser air is essential for maintaining condensing unit capacity and operating efficiency. When determining unit placement, careful consideration must be given to assure proper air flow across the condenser heat transfer surface. Failure to heed these considerations will result in warm air recirculation and coil air flow starvation.

Warm air recirculation occurs when discharge air from the condenser fans is recycled back at the condenser coil inlet. Coil starvation occurs when free air flow to the condenser is restricted.

Both warm air recirculation and coil starvation cause reductions in unit efficiency and capacity. In addition, in more severe cases, nuisance unit shutdowns will result from excessive head pressures. Accurate estimates of the degree of efficiency and capacity reduction are not possible due to the unpredictable effect of varying winds.

When hot gas bypass is used, reduced head pressure increases the minimum ambient condition for proper operation. In addition, wind tends to further reduce head pressure. Therefore, it is advisable to protect the air-cooled condensing unit from continuous direct winds exceeding 10 miles per hour.

Debris, trash, supplies, etc., should not be allowed to accumulate in the vicinity of the air-cooled condensing unit. Supply air movement may draw debris between coil fins and cause coil starvation. Special consideration should be given to units operating in low ambient temperatures.

Condenser coils and fan discharge must be kept free of snow and other obstructions to permit adequate air flow for satisfactory unit operation.

Effect of Altitude on Capacity

Condensing unit capacities given in the performance data tables are at sea level. At elevations substantially above sea level, the decreased air density will decrease condenser capacity and, therefore, unit capacity and efficiency. The adjustment factors in [Table 4, p. 14](#) can be applied directly to the catalog performance data to determine the unit's adjusted performance.

Ambient Considerations

Start-up and operation at lower ambients requires sufficient head pressure be maintained for proper expansion valve operation. At higher ambients, excessive head pressure may result. Standard operating conditions are 40°F to 125°F (115°F max ambient for EVP chiller). With a low ambient damper, operation down to 0°F is possible. Minimum ambient temperatures are based on still conditions (winds not exceeding five mph). Greater wind velocities will result in increased minimum operating ambients. Units with hot gas bypass have a minimum operating ambient temperature of 10°F. For proper operation outside these recommendations, contact the local Trane sales office.

Coil Frost Protection

FROSTAT™ is standard on condensing units when the VAV option is ordered. FROSTAT consists of a ship-with thermostat for field installation on the suction line. A timer is also factory-installed to avoid short cycling. FROSTAT cycles the compressor off when the suction line is below 30°F. Refer to S/S-EB-43 for more detail.

When hot gas valves must be used on 20 to 120-ton units, they can be ordered as a miscellaneous option. Twenty to 30-ton units require one valve; 40 to 60-ton units also require one valve except when no system control option is selected; this option requires two valves. Eighty to 120-ton units require one valve when Supply Air VAV control is selected. Two valves are required on all other 80 to 120-ton control options.

Refrigerant Piping

Special consideration must always be given to oil return. Minimum suction gas velocities must always be maintained for proper oil return. Utilize appropriate piping tools for line sizing such as the CDS Refrigerant Piping Program SS-APG007-EN Tube Size and Component Selection Application Guide. For special applications, call Clarksville Product Support.

Note: *Under certain conditions, R410a refrigerant can present special challenges with piping and system design. Whenever refrigerant line set lengths approach 150 equivalent feet and/or design ambient temperature exceeds 115 degrees F, contact your Trane Account Executive to review application requirements.*

Remote Chiller Evaporator

Water Treatment

Using untreated or improperly treated water may result in scaling, erosion, corrosion, and algae or slime buildup in the heat exchanger that will adversely affect system capacity. Proper water treatment must be determined locally and depends on the type of system and local water characteristics. Neither salt nor brackish water is recommended, either will lead to a shortened heat exchanger life. Trane encourages employment of a qualified water treatment specialist, familiar with local water conditions, to assist in the establishment of a proper water treatment program.

Water Flow Limits

The minimum and maximum water flow rates are given in the General Data table. Water flow rates below the tabulated values will result in laminar flow causing freeze-up problems, scaling,



Application Considerations

stratification and poor system control. Flow rates exceeding the maximum listed may result in very high pressure drop, erosion of the heat exchanger and damage to the water flow switch.

Water Temperature Limits

Catalog chiller performance data is based on a water temperature drop of 10°F. Full load chilled water temperature drops from 8 to 14°F may be used as long as minimum and maximum water temperature and minimum and maximum flow rates are not violated. Leaving water temperatures below 42°F require freeze protection down to 15°F. The maximum water temperature that can be circulated through the chiller when the unit is not operating is 125°F. Evaporator damage may result above this temperature.

Short Water Loops

Adequate chilled water system water volume is an important system design parameter because it provides for stable chilled water temperature control and helps limit unacceptable short cycling of chiller compressors. Typically, a five-minute water loop circulation time is sufficient to prevent short water loop issues. Therefore, as a guideline, ensure the volume of water in the chilled water loop equals or exceeds five times the evaporator flow rate. For systems with a rapidly changing load profile the amount of volume should be increased.

Water Piping

Foreign matter in the chilled water system will increase pressure drop and reduce water flow. Installation of a properly selected strainer is also necessary to prevent debris larger than 0.039" from entering the heat exchanger. All building water piping must be thoroughly flushed before making the final piping connections to the heat exchanger. To reduce heat loss and prevent condensation, insulation should be applied to piping. Expansion tanks are also generally required to accommodate chilled water volume changes.

Selection Procedure

Net capacity curves for the RAUJ condensing units are given in the performance data section. The resultant point of intersection will be the system design balance point. The design operating suction temperature and capacity can then be read directly from the graph.

Note: It is usually necessary to account for suction and liquid line losses in the performance accordingly. The actual losses are determined by the interconnecting piping.

To plot the DX evaporator performance curve it is only necessary to obtain gross evaporator capacities for the given entering air conditions and cfm at two different saturated suction temperatures. The Trane Refrigeration Coil Computer Selection Program can be used to conveniently provide the necessary evaporator capacity values at the selected suction temperatures.

Selection Example

The RAUJ 20 to 120-Ton TOPSS selection program provides the ability to generate performance output for pre-selected Trane Modular Climate Changer evaporator coils with the RAUJ condensing units. To select a condensing unit and evaporator coil not available in the RAUJ TOPSS program, the example below can be used to cross-plot an evaporator coil with known performance with the RAUJ condensing unit

From the Trane Refrigeration Coil Computer Selection Program:

DX Evap Coil = Model Number DFDB42 - 42" X 60" / 4 Row / 144 FPF - FD/Delta-flo E

Entering Coil Conditions = 80/67 DB/WB and 95 F Ambient - 8500 CFM

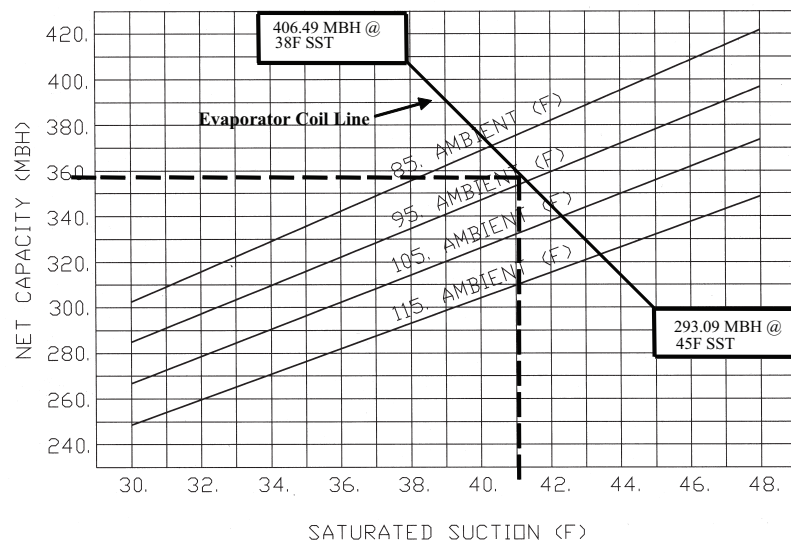
Coil Performance @ 38F SST - 406.49 MBH Total

Coil Performance @ 45F SST - 293.09 MBH Total

Balance Point at 95F Ambient = 358 MBH @ 41.3 SST

Coils are identical fin series and circuiting on both simulations.

Figure 1. 30 Ton condensing unit performance - RAUJ-C30 (60 Hz)



By plotting the two coil performance outputs across the RAUJC30 Net Capacity curve at their respective total MBH at the defined saturated suction temperatures, we can see that the condenser/evaporator coil combination, at 95 F ambient, provides 358 MBH Net Capacity at 41.3 SST.



Model Number Descriptions

20 to 60-Ton Units¹

DIGIT 1 – UNIT TYPE

R = Condensing Unit

DIGIT 2 – CONDENSER

A = Air Cooled

DIGIT 3 – AIRFLOW

U = Upflow

DIGIT 4 – DEVELOPMENT SEQUENCE

J = Third

DIGITS 5,6,7 – NOMINAL CAPACITY

C20 = 20 Tons

C25 = 25 Tons

C30 = 30 Tons

C40 = 40 Tons

C50 = 50 Tons

C60 = 60 Tons

DIGIT 8 – VOLTAGE AND START CHARACTERISTICS

E = 200/60/3 XL

D = 415/50/3 XL

F = 230/60/3 XL

4 = 460/60/3 XL

5 = 575/60/3 XL

9 = 380/50/3 XL

DIGIT 9 – SYSTEM CONTROL

B = No System Control

C = Constant Volume Control

E = Supply Air VAV Control

P = EVP Control

DIGIT 10 – DESIGN SEQUENCE

(Factory Assigned)

A = First

B = Second

Etc.

DIGIT 11 – AMBIENT CONTROL

0 = Standard

1 = 0°F (Low Ambient Dampers)

DIGIT 12 – AGENCY APPROVAL

0 = None

3 = cULus (not available for 50 Hz)

DIGIT 13

A = Non Fused Unit Disconnect Switch

DIGIT 14

B = Hot Gas Bypass Valve

DIGIT 15

D = Suction Service Valves

DIGIT 16

F = Pressure Gauges and Piping

DIGIT 17

G = Return Air Sensor

DIGIT 18

H = Copper Condenser Fins

DIGIT 19

C = Remote Chiller Evaporator & Install Kit

T = Flow Switch (EVP Control Only)

DIGIT 20

1 = Spring Isolators

2 = Neoprene Isolators

80 to 120-Ton Units¹

DIGIT 1 – UNIT TYPE

R = Remote Condensing Unit

DIGIT 2 – CONDENSER

A = Air-Cooled

DIGIT 3 – AIRFLOW

U = Upflow

DIGIT 4 – DEVELOPMENT SEQUENCE

J = Third

DIGITS 5,6,7 – NOMINAL CAPACITY

C80 = 80 Tons

D10 = 100 Tons

D12 = 120 Tons

DIGIT 8 – VOLTAGE AND START CHARACTERISTICS

E = 200/60/3 XL

F = 230/60/3 XL

4 = 460/60/3 XL

5 = 575/60/3 XL

* = 380/50/3 XL²

* = 415/50/3 XL²

DIGIT 9 – SYSTEM CONTROL

B = No System Control

E = Supply Air VAV Control

P = EVP Control

DIGIT 10 – DESIGN SEQUENCE

(Factory Assigned)

A = First

B = Second

Etc.

DIGIT 11 – AMBIENT CONTROL

0 = Standard

1 = 0°F (Low Ambient Dampers)

DIGIT 12 – AGENCY APPROVAL

0 = None

3 = cULus (not available for 50 Hz)

DIGIT 13 – NUMBER OF CIRCUITS

2 = Dual (All 80-120 Ton)

DIGIT 14

B = Hot Gas Bypass Valve

DIGIT 15

B = Hot Gas Bypass Valve

DIGIT 15

D = Suction Service Valves

DIGIT 16

F = Pressure Gauges and Piping

DIGIT 17

H = Copper Condenser Fins

DIGIT 18

1 = Spring Isolators

DIGIT 19

C = Remote Chiller Evap & Install Kit

3 = Flow Switch (EVP Control only)

¹ The service digit for each model number contains 21 digits; all 21 digits must be referenced.

² Contact the local Trane Sales Office for ordering information regarding 80-120 50Hz models.

General Data

Table 1. General data - 20-120 ton condensing units

Model Number	RAUJ-C20	RAUJ-C25	RAUJ-C30	RAUJ-C40	RAUJ-C50	RAUJ-C60	RAUJ-C80	RAUJ-D10	RAUJ-D12
Compressor Data									
Type	Scroll	Scroll	Scroll	Scroll	Scroll	Scroll	Scroll	Scroll	Scroll
Manifolded Sets									
Circuit 1	10T + 10T	10T + 13.5T	15T + 15T	10T + 10T	11.5T + 13.5T	15T + 15T	15T + 15T + 15T	15T + 15T + 20T	20T + 20T + 20T
Circuit 2				10T + 10T	11.5T + 13.5T	15T + 15T	15T + 15T + 15T	15T + 15T + 20T	20T + 20T + 20T
Unit Capacity Steps (%)	100-50	100-42	100-50	100-75-50-25	100-73-46-23	100-75-50-25	100-83-66-50-33-17	100-80-60-45-30-15	100-83-66-50-33-17
Condenser Fan Data									
Qty/Fan Dia. Type	2/26"/Prop	3/26"/Prop	3/26"/Prop	4/26"/Prop	6/26"/Prop	6/26"/Prop	8/26"/Prop	12/26"/Prop	12/26"/Prop
Fan Drive Type	Direct	Direct	Direct	Direct	Direct	Direct	Direct	Direct	Direct
No. of Motors/HP Ea.	2/1.0	3/1.0	3/1.0	4/1.0	6/1.0	6/1.0	8/1.0	12/1.0	12/1.0
Nominal Total CFM	14600	20700	20700	26790	36890	40490	56490	73890	76280
Condenser Coil Data									
Number of Coils/ Size (Inches)	2/48x71	2/48x71	2/48x71	2/68x71	2/58x96	2/68x96	4/68x71	4/58x96	4/68x96
Face Area (Sq. Ft.)	47.3	47.3	47.3	67.1	77.3	90.7	134.1	154.7	181.3
Rows/Fin Per Ft.	3/192	3/192	3/192	4/192	3/192	3/192	3/192	3/192	4/192
Condenser Storage Capacity (Lbs) ^(a)	70	70	70	134	117	143	196	215	321
Refrigerant Data^(b)									
No. Refrigerant Circuits	1	1	1	2	2	2	2	2	2
Refrigerant Type	R410a	R410a	R410a	R410a	R410a	R410a	R410a	R410a	R410a
Refrigerant Operating Charge (Lbs.)/Unit ^(c) ^(d)	25	25	25	50	42	50	70	83	126
Min. Outdoor Air Temperature for Mechanical Cooling									
Standard Ambient Operating Range (F)	40-125	40-125	40-125	40-125	40-125	40-125	40-125	40-125	40-125
Low Ambient Option (F)	0	0	0	0	0	0	0	0	0
Cabinet Dimensions									
Length (Inches)	88.25	88.25	88.25	88.25	113.82	113.82	176.25 in,	227.25 in	227.25 in
Width (Inches)	60.12	61.12	60.12	88.25	88.25	88.25	88.25	88.25	88.25
Height (Inches)	68	68	68	73	73	73	73	73	73

(a) Condenser storage capacity is given at conditions of 95°F outdoor temperature, and 95% full.

(b) Refer to Refrigerant Piping in the Application Considerations section.

(c) Operating charge is approximate for condensing unit only, and does not include charge for low side or interconnecting lines.

(d) Condensing units are shipped with a nitrogen holding charge only.

Table 2. General data - 20 - 120 ton remote chillers

Model Number	RAUJ-C20	RAUJ-C25	RAUJ-C30	RAUJ-C40	RAUJ-C50	RAUJ-C60	RAUJ-C80	RAUJ-D10	RAUJ-D12
Shipping weight, lbs	44	84	113	90	135	157	208	292	320
Operating weight, lbs	56	104	142	131	206	244	330	473	520
No. of refrigerant circuits	1	1	1	2	2	2	2	2	2
Water volume, Gal	1.4	2.2	3.3	4.6	7.9	9.7	13.6	20.1	22.2
Chiller refrig charge @ ARI condition, lbs	0.9	1.5	2.2	3.1	5.3	6.4	9.0	13.3	14.7



General Data

Table 2. General data - 20 - 120 ton remote chillers

Model Number	RAUJ-C20	RAUJ-C25	RAUJ-C30	RAUJ-C40	RAUJ-C50	RAUJ-C60	RAUJ-C80	RAUJ-D10	RAUJ-D12
Minimum water flow rate, GPM	24	30	34	46	59	68	92	116	136
Maximum water flow rate, GPM	69	89	100	136	176	201	275	346	407
Chiller Water Supply/Return Pipe Size, in	2.0	2.0	2.0	3.0	3.0	3.0	4.0	4.0	4.0

Notes:

1. All heat exchangers are brazed plate.
2. All heat exchangers are single circuit on the water side.
3. Shipping and operating weights are approximate.
4. Refrigerant charge is approximate and for chiller only.
5. Applications with leaving water temperature below 42°F require freeze protection down to 15°F.
6. Maximum chiller operating ambient is 115°F.

Table 3. EER data - condensing unit only^(a)

	Net Cap (MBH)	Total Compressor kW	Condenser Fan kW Each/Total	Control kW	Total Power kW	EER	IPLV
RAUJ-C20	264,532	20.5	0.9/1.8	0.25	22.6	11.6	15.8
RAUJ-C25	321,554	24.0	0.9/2.7	0.25	26.9	11.9	15.6
RAUJ-C30	393,683	31.9	0.9/2.7	0.25	35.0	11.2	16.2
RAUJ-C40	533,734	42.1	0.9/3.6	0.40	46.1	11.5	16.1
RAUJ-C50	663,280	53.7	0.9/5.4	0.40	59.5	11.1	15.7
RAUJ-C60	760,839	61.4	0.9/5.4	0.40	67.3	11.3	16.4
RAUJ-C80	1,078,895	95.8	0.9/7.2	0.50	103.6	10.4	16.5
RAUJ-D10	1,316,567	108.3	0.9/10.8	0.50	119.6	11.0	16.2
RAUJ-D12	1,593,529	130.5	0.9/10.8	0.50	142.0	11.2	16.8

Note: Capacity is rated in accordance with ARI 365 - 95F Ambient, 45F Saturated Suction Temperature

(a) Condensing unit only ratings are in accordance with ARI standard 365. Full load ratings are at 95°F entering air temperature, and refrigerant conditions entering the condensing unit of 45°F saturated and 60°F actual temperature. Part load ratings are at 80°F entering air temperature and refrigerant conditions entering the condensing unit of 50°F saturated suction and 65°F actual temperature.

Table 4. Altitude correction multiplier for capacity

Altitude (Ft.)	2,000	4,000	6,000	8,000	10,000
Condensing Unit Only	0.982	0.960	0.933	0.902	0.866
Condensing Unit / Air Handling Unit Combination	0.983	0.963	0.939	0.911	0.881
Condensing Unit With Evap.	0.986	0.968	0.947	0.921	0.891

Performance Data

60 Hz Data

Figure 2. 20 Ton condensing unit performance — RAUJ-C20 (60 HZ)

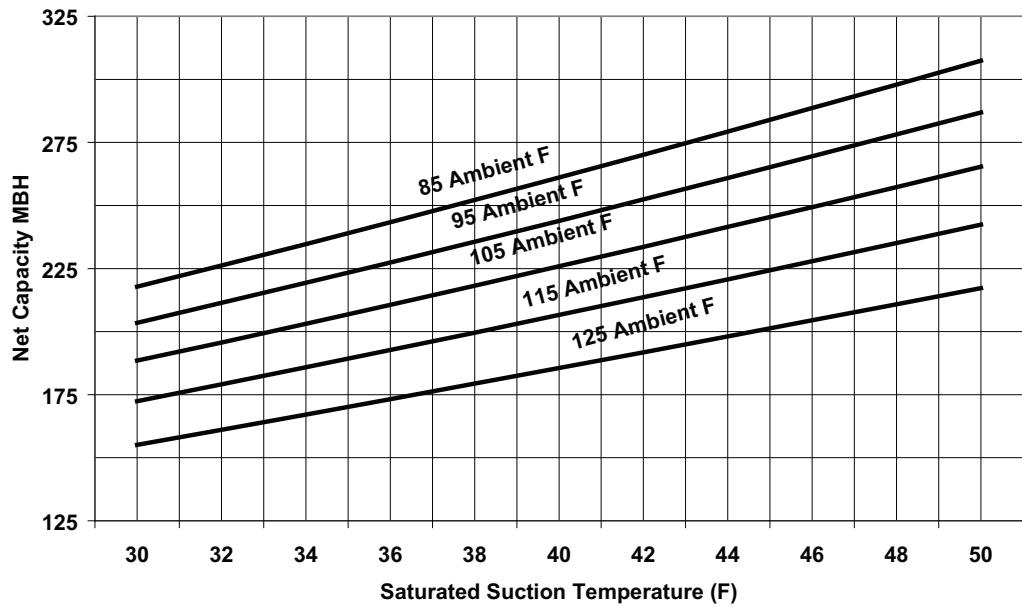


Figure 3. 25 Ton condensing unit performance — RAUJ-C25 (60 HZ)

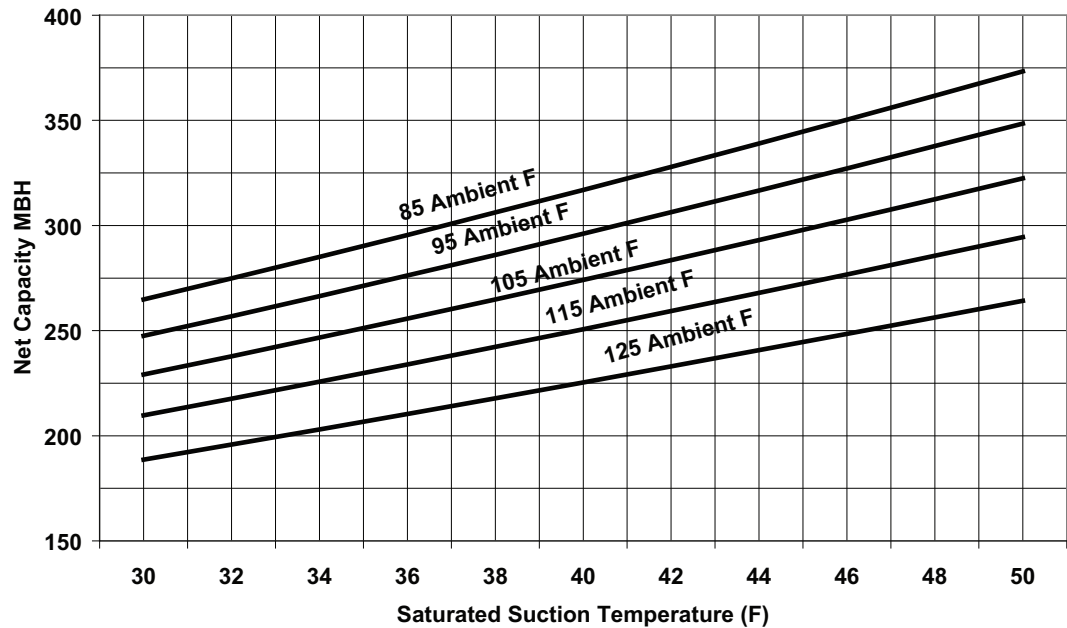


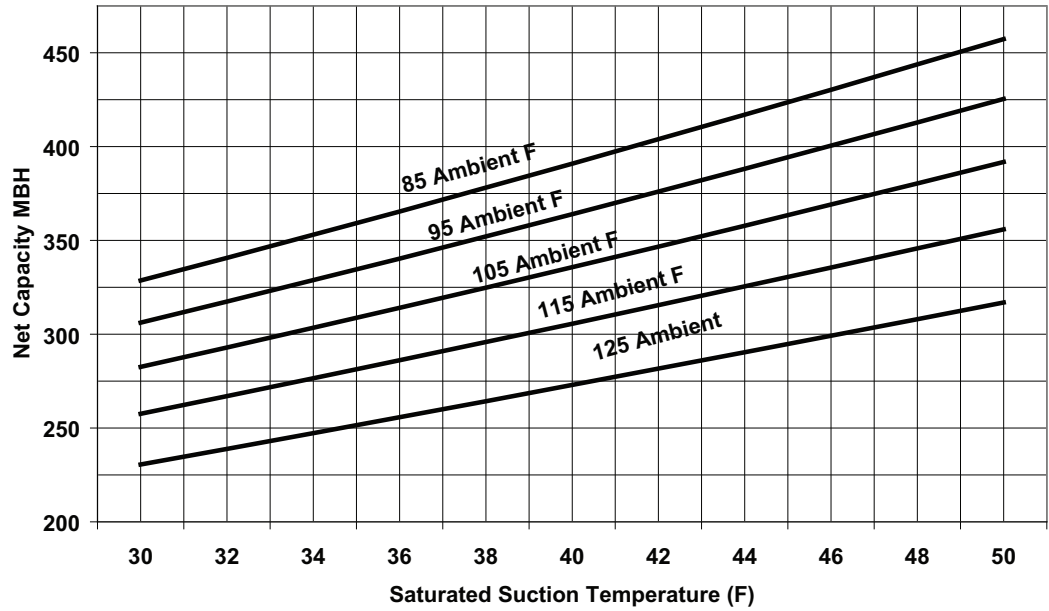
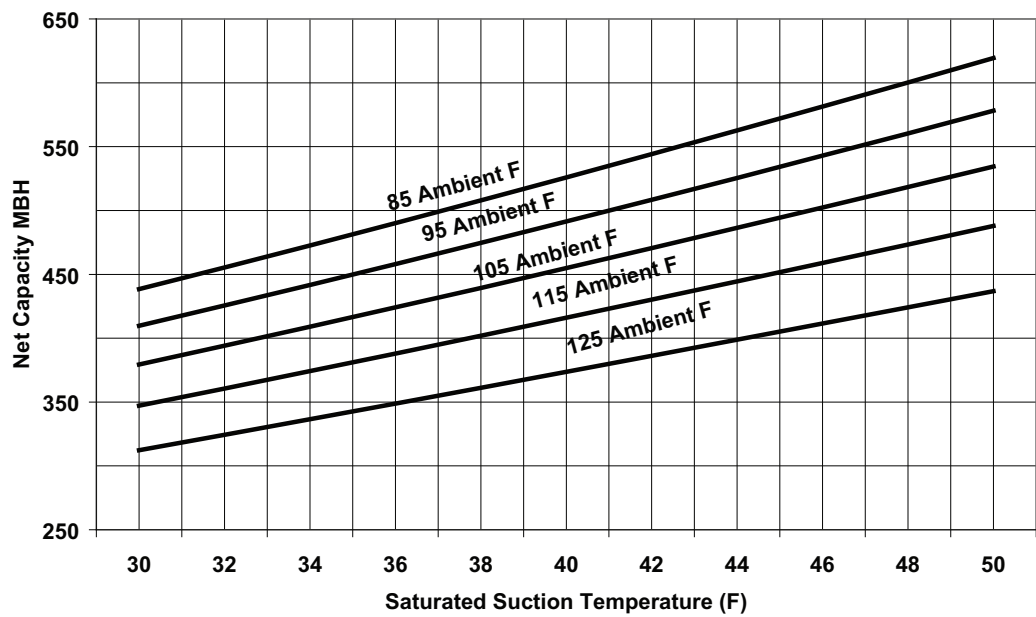
Figure 4. 30 Ton condensing unit performance — RAUJ-C30 (60 HZ)

Figure 5. 40 Ton condensing unit performance — RAUJ-C40 (60 HZ)


Figure 6. 50 Ton condensing unit performance — RAUJ-C50 (60 HZ)

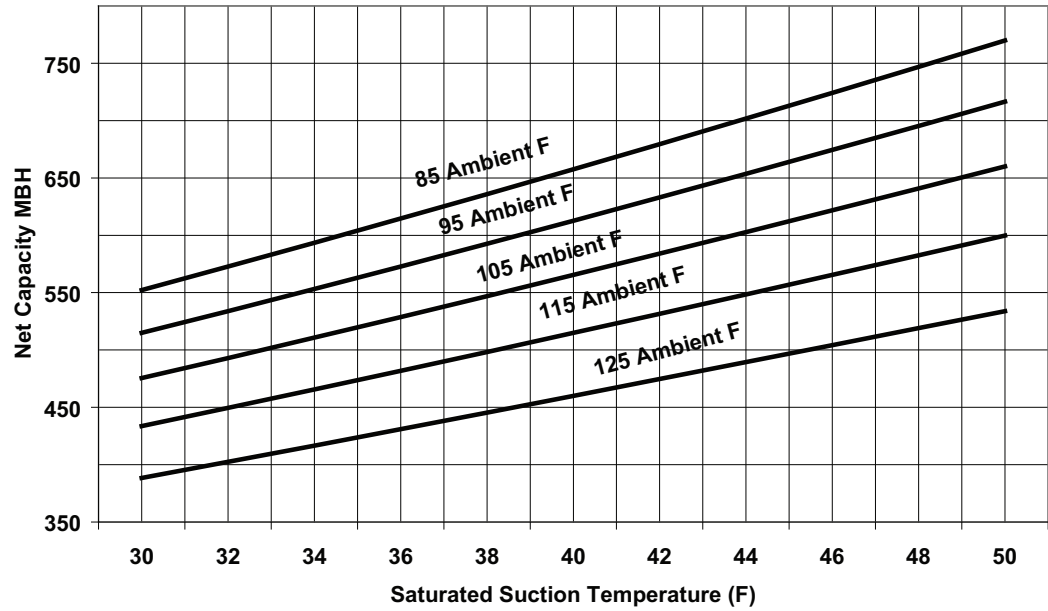


Figure 7. 60 Ton condensing unit performance — RAUJ-C60 (60 HZ)

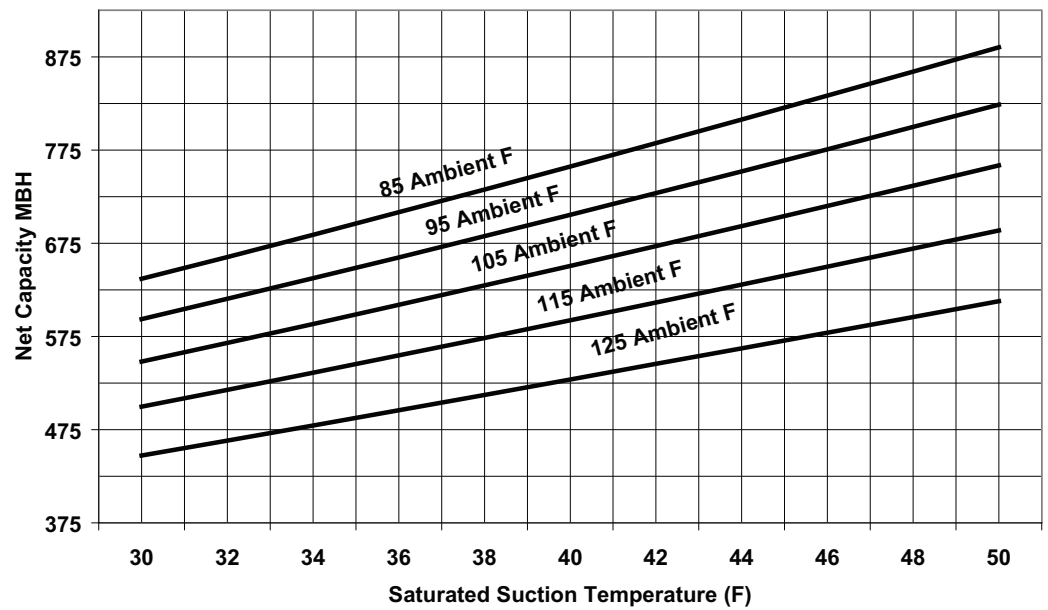


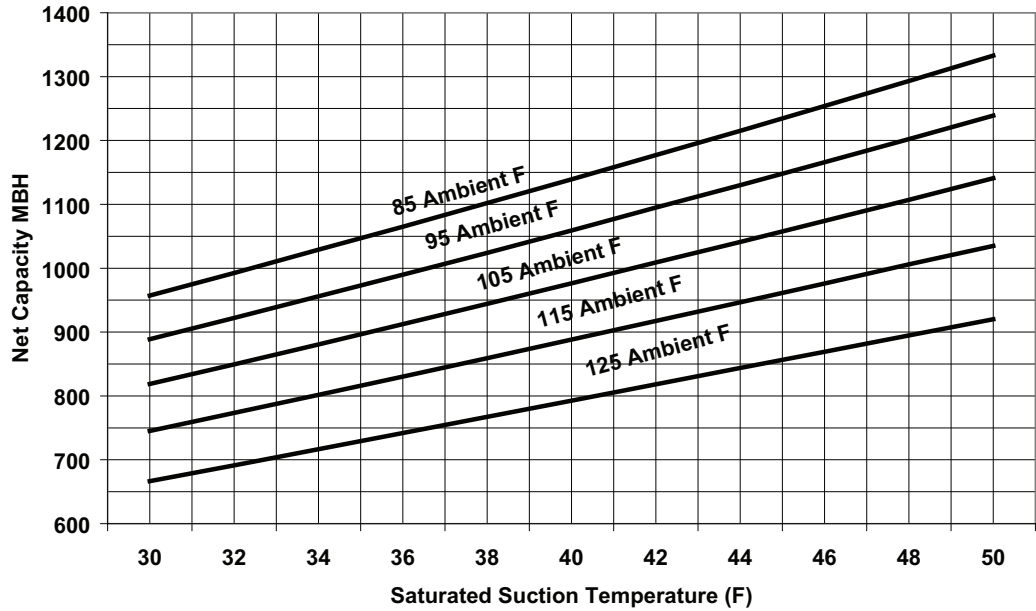
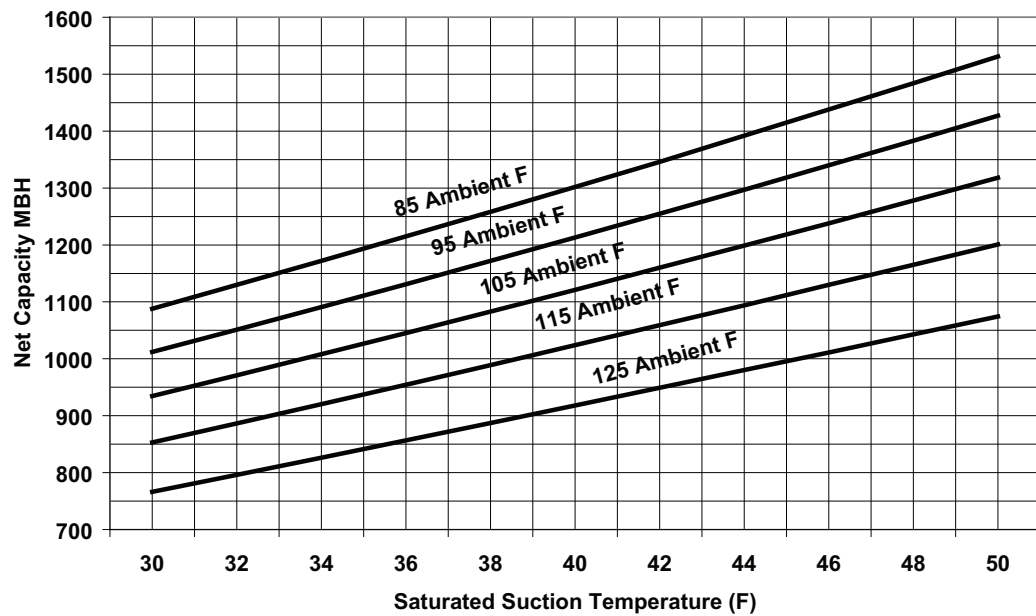
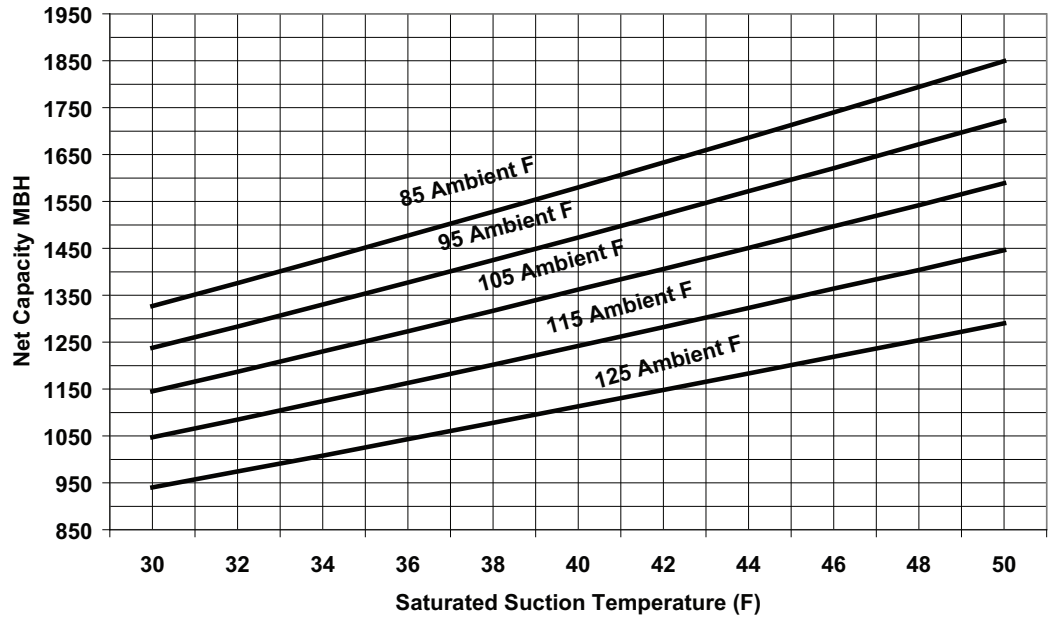
Figure 8. 80 Ton condensing unit performance — RAUJ-C80 (60 HZ)

Figure 9. 100 Ton condensing unit performance — RAUJ-D10 (60 HZ)


Figure 10. 120 Ton condensing unit performance – RAUJ-D12 (60 HZ)



50 Hz Data

Figure 11. 20 Ton condensing unit performance – RAUJ-C20 (50 HZ)

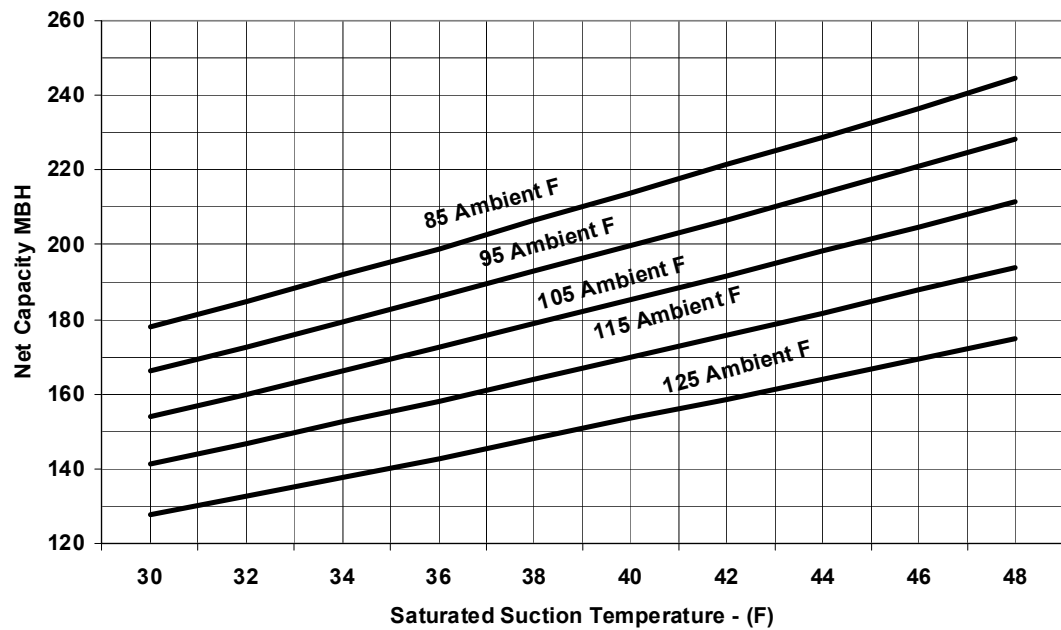


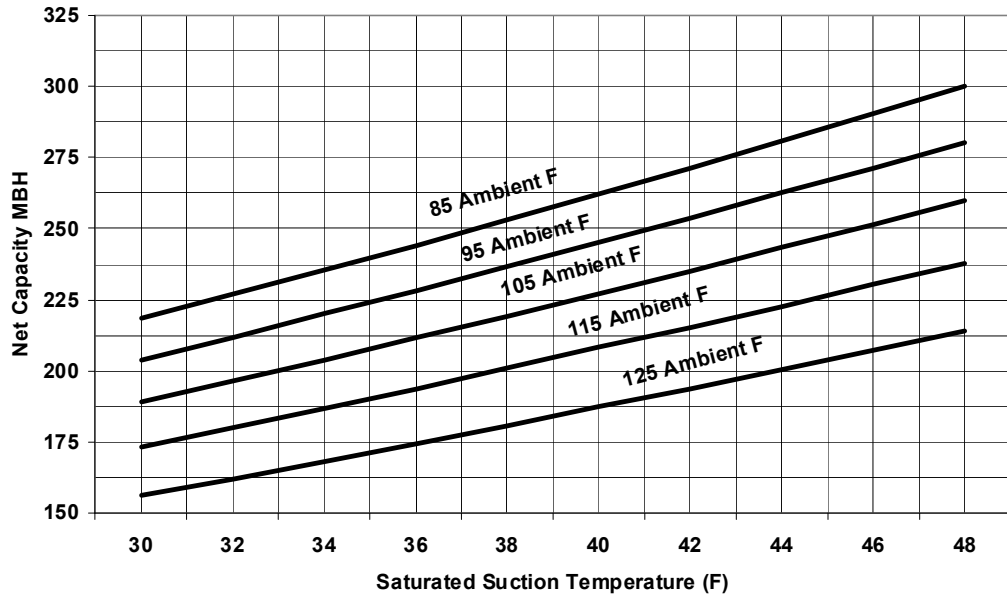
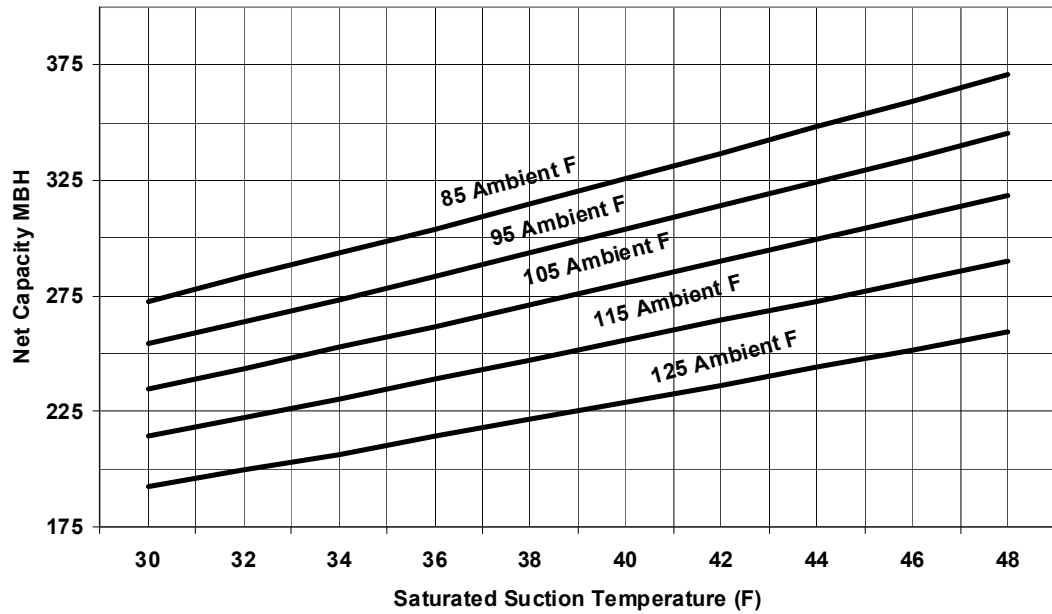
Figure 12. 25 Ton condensing unit performance — RAUJ-C25 (50 HZ)

Figure 13. 30 Ton condensing unit performance — RAUJ-C30 (50 HZ)


Figure 14. 40 Ton condensing unit performance – RAUJ-C40 (50 HZ)

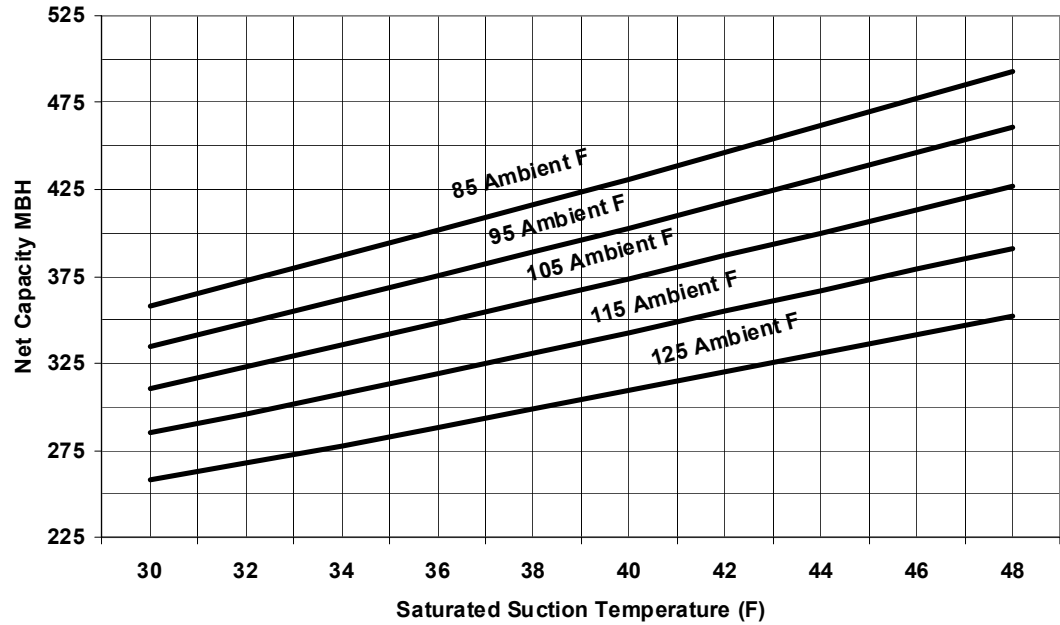


Figure 15. 50 Ton condensing unit performance – RAUJ-C50 (50 HZ)

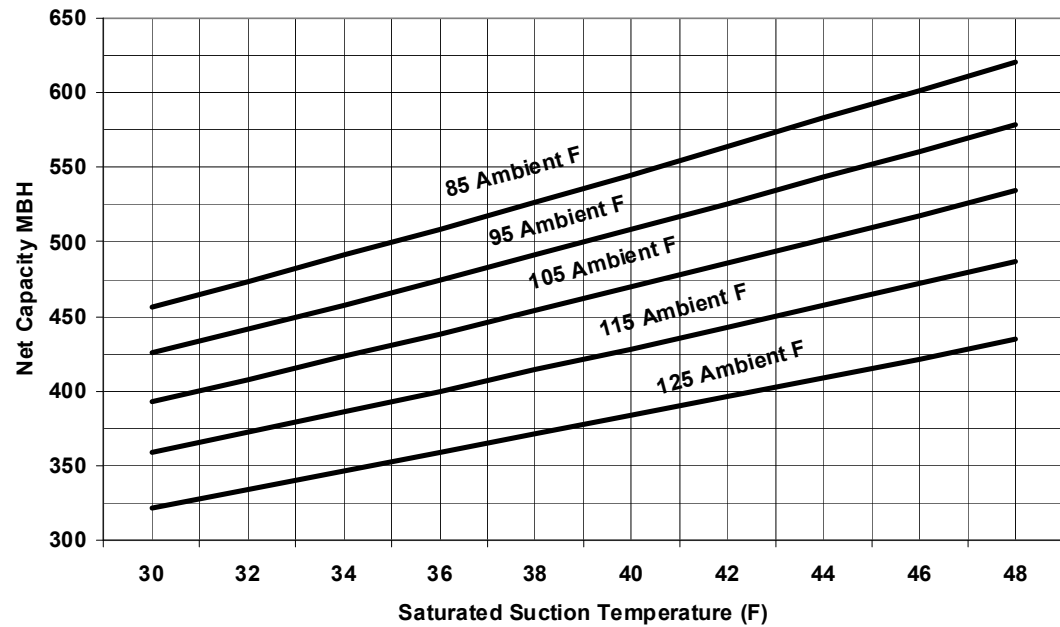


Figure 16. 60 Ton condensing unit performance — RAUJ-C60 (50 HZ)

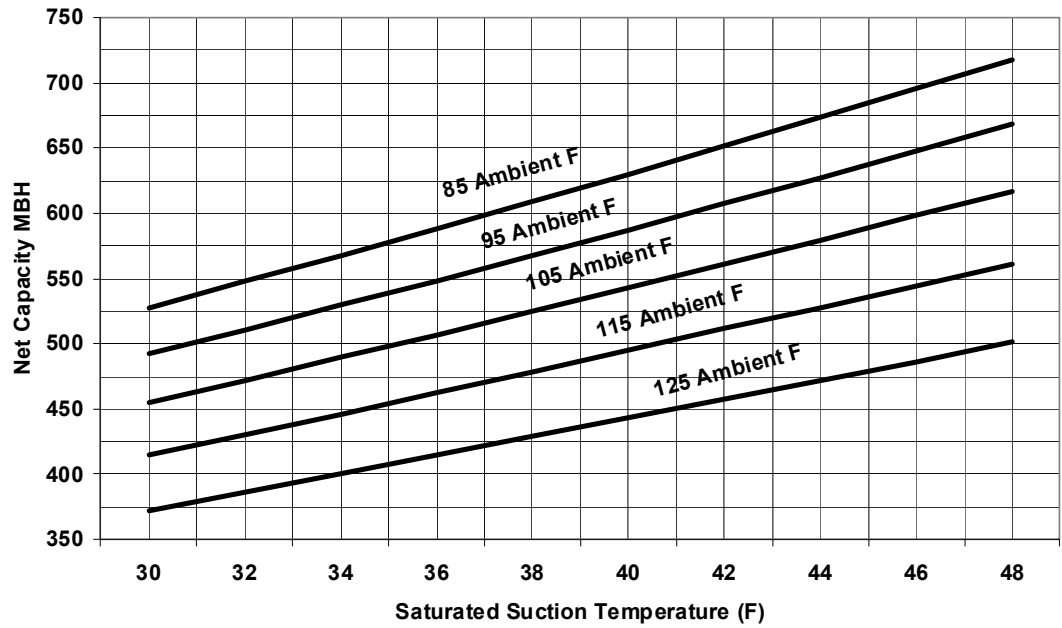


Figure 17. 80 Ton condensing unit performance — RAUJ-C80 (50 HZ)

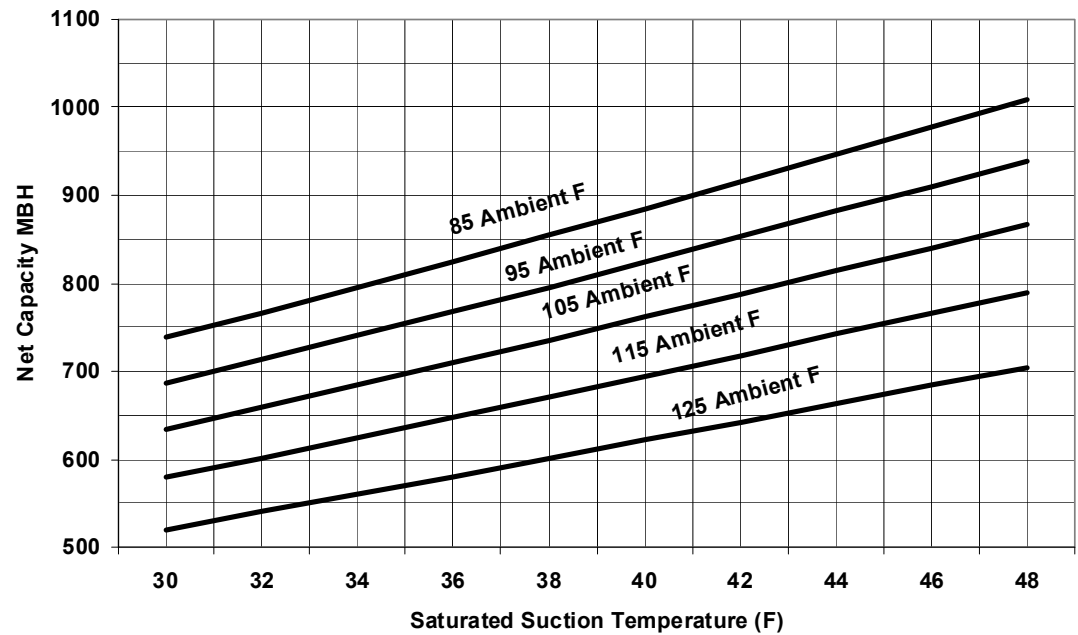


Figure 18. 100 Ton condensing unit performance – RAUJ-D10 (50 HZ)

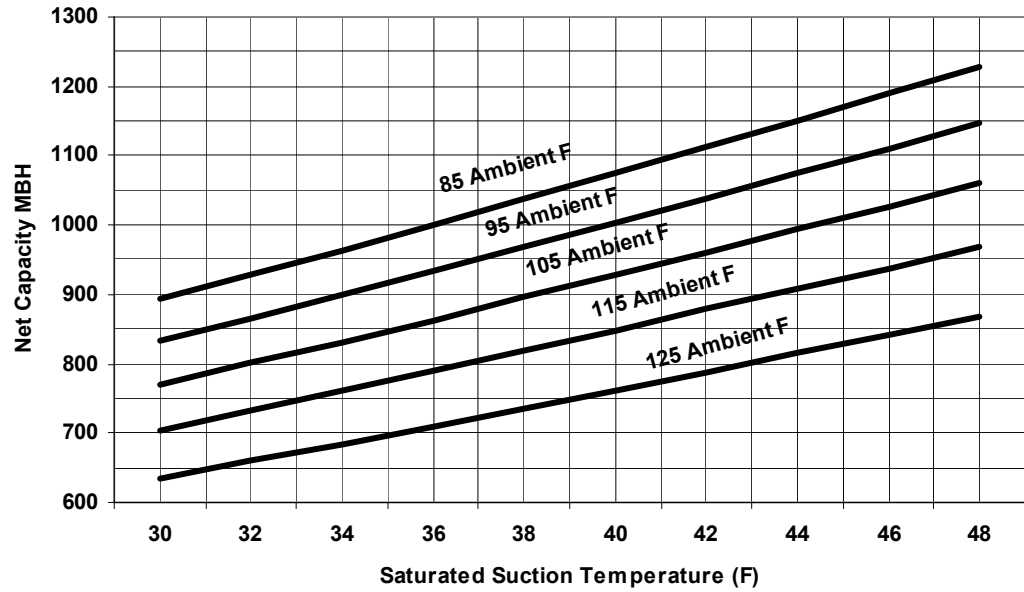
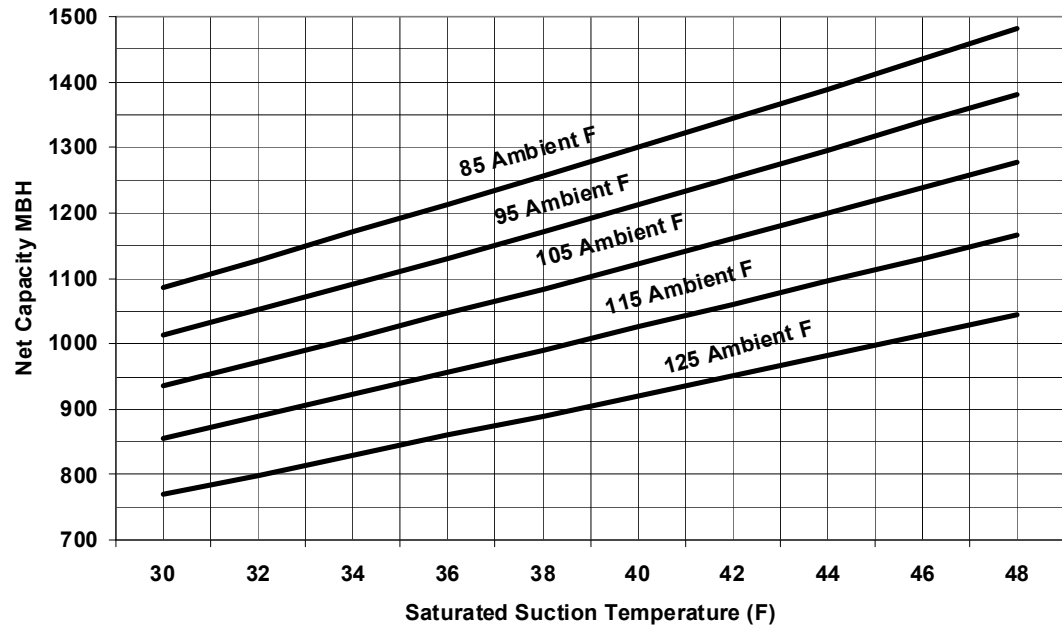


Figure 19. 120 Ton condensing unit performance – RAUJ-D12 (50 HZ)





Performance Data

Table 5. System Performance Data — 20-120 Ton RAUJ with Remote EVP Chiller

Model	LWFT(F)	Entering Condenser Air Temperature (F)							
		85		95		105		115	
		Capacity Tons	Compr kW	Capacity Tons	Compr kW	Capacity Tons	Compr kW	Capacity Tons	Compr kW
RAUJ C20	40	18.7	17.1	17.6	19.1	16.3	21.3	15.0	23.7
	42	19.5	17.4	18.3	19.3	17.0	21.5	15.6	23.9
	44	20.2	17.6	18.9	19.5	17.6	21.7	16.1	24.1
	46	20.9	17.8	19.6	19.7	18.2	21.9	16.7	24.3
	48	21.5	18.0	20.2	19.9	18.8	22.1	17.2	24.5
	50	22.2	18.2	20.9	20.1	19.4	22.3	17.8	24.7
RAUJ C25	40	23.3	20.3	21.9	22.6	20.3	25.2	18.6	28.1
	42	24.3	20.5	22.9	22.8	21.2	25.4	19.4	28.4
	44	25.2	20.8	23.6	23.1	21.9	25.7	20.1	28.6
	46	26.0	21.0	24.4	23.3	22.7	25.9	20.8	28.8
	48	26.9	21.2	25.2	23.5	23.4	26.1	21.4	29.0
	50	27.8	21.4	26.0	23.7	24.1	26.4	22.1	29.3
RAUJ C30	40	28.6	26.7	26.7	29.7	24.7	33.1	22.6	36.9
	42	29.8	27.1	27.9	30.1	25.8	33.5	23.5	37.2
	44	30.8	27.5	28.8	30.5	26.6	33.8	24.3	37.6
	46	31.8	27.8	29.7	30.8	27.5	34.2	25.1	37.9
	48	32.8	28.2	30.7	31.2	28.4	34.5	25.9	38.2
	50	33.9	28.5	31.7	31.5	29.2	34.9	26.7	38.6
RAUJ C40	40	36.9	34.7	34.8	38.7	32.4	43.2	29.7	48.2
	42	37.9	35.0	35.7	39.0	33.2	43.5	30.6	48.5
	44	39.3	35.5	37.0	39.5	34.5	44.0	31.7	48.9
	46	40.7	35.9	38.3	39.9	35.7	44.4	32.8	49.4
	48	42.2	36.4	39.7	40.4	37.0	44.9	34.0	49.8
	50	43.7	36.9	41.1	40.9	38.2	45.3	35.2	50.2
RAUJ C50	40	47.6	44.8	44.6	50.1	41.2	56.0	37.6	62.5
	42	49.7	45.5	46.5	50.7	43.0	56.6	39.2	63.2
	44	51.4	46.0	48.1	51.3	44.5	57.2	40.6	63.7
	46	53.1	46.5	49.7	51.8	45.9	57.7	41.9	64.2
	48	54.9	47.1	51.3	52.3	47.4	58.2	43.2	64.7
	50	56.6	47.6	52.9	52.9	48.9	58.8	44.6	65.2
RAUJ C60	40	52.9	50.7	49.5	56.7	45.8	63.5	41.9	71.0
	42	55.2	51.4	51.7	57.4	47.8	64.2	43.6	71.7
	44	57.1	52.0	53.4	58.0	49.4	64.8	45.1	72.2
	46	59.0	52.6	55.2	58.7	51.1	65.4	46.6	72.8
	48	61.0	53.2	57.0	59.3	52.7	66.0	48.1	73.4
	50	62.9	53.9	58.8	59.9	54.4	66.6	49.6	74.0
RAUJ C80	40	76.9	78.6	71.8	88.6	66.3	99.5	60.5	111.3
	42	80.4	79.6	75.0	89.6	69.3	100.5	63.2	112.2
	44	83.1	80.5	77.6	90.5	71.6	101.3	65.4	113.0
	46	85.9	81.3	80.1	91.3	74.0	102.2	67.6	113.8
	48	88.7	82.2	82.8	92.2	76.4	103.0	69.8	114.6
	50	91.5	83.0	85.4	93.1	78.9	103.9	72.0	115.4

Table 5. System Performance Data – 20-120 Ton RAUJ with Remote EVP Chiller (continued)

Model	LWFT(F)	Entering Condenser Air Temperature (F)							
		85		95		105		115	
		Capacity Tons	Compr kW	Capacity Tons	Compr kW	Capacity Tons	Compr kW	Capacity Tons	Compr kW
RAUJ D10	40	94.1	89.6	87.9	101.0	81.4	113.4	74.5	126.9
	42	98.2	90.8	91.8	102.1	85.0	114.5	77.8	128.0
	44	101.6	91.7	95.0	103.1	88.0	115.5	80.6	128.8
	46	105.1	92.6	98.2	104.0	91.0	116.4	83.3	129.7
	48	108.5	93.6	101.5	105.0	94.0	117.3	86.1	130.6
	50	112.0	94.5	104.8	106.0	97.0	118.3	88.9	131.5
RAUJ D12	40	112.2	107.2	105.3	120.6	97.6	135.7	89.4	152.3
	42	117.2	108.6	109.9	122.1	101.8	137.2	93.2	153.8
	44	121.1	109.7	113.5	123.3	105.2	138.4	96.2	155.1
	46	125.1	110.9	117.2	124.5	108.6	139.7	99.3	156.4
	48	129.2	112.0	121.0	125.7	112.1	141.0	102.5	157.7
	50	133.2	113.2	124.8	126.9	115.5	142.2	105.6	159.0

Note:
1. Performance data at 10°F water temperature drop and 60 Hz.
2. Leaving water temperature (LWT) below 42°F requires freeze protection to 15°F.
3. 40F LWT performance includes 20% glycol.

Table 6. Chiller Water Pressure Drop, Ft H2O

Flow GPM	Size, tons								
	20	25	30	40	50	60	80	100	120
25	3.2								
30	4.5	2.7							
35	6.0	3.6							
40	7.7	4.6	2.6						
45	9.6	5.7	3.3						
50	11.6	6.9	4.0	4.8					
60	16.3	9.6	5.6	6.8	4.3				
70	21.6	12.8	7.5	9.1	5.8				
80		16.3	9.6	11.7	7.4	5.3			
90		20.2	12.0	14.7	9.3	6.6			
100			14.6	18.0	11.4	8.0	4.5		
120				25.5	16.1	11.4	6.4	3.4	
140					21.5	15.2	8.5	4.5	
160					27.8	19.7	11.0	5.9	5.0
180						24.6	13.8	7.4	6.3
200							16.9	9.0	7.7
240							23.9	12.8	11.0
280								17.2	14.8
320								22.2	19.1
360								27.9	24.0
400									29.3

Figure 20. Remote EVP Glycol Freeze Protection

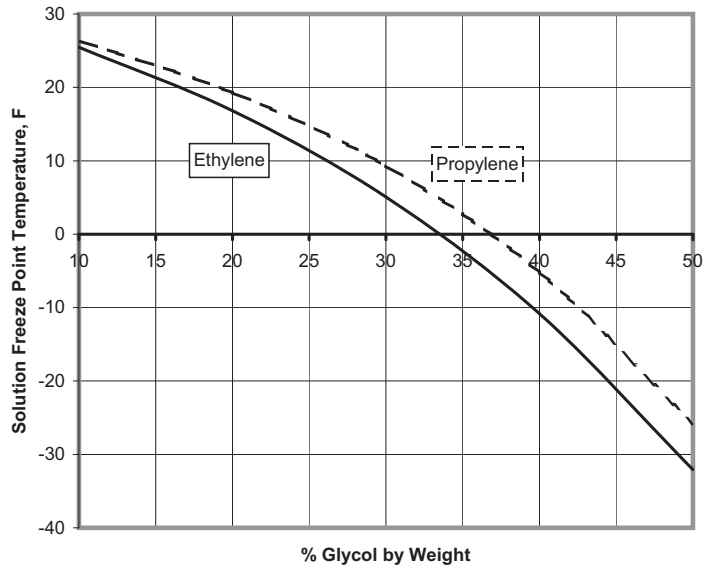


Figure 21. Remote EVP Ethylene Glycol GPM, Capacity, and Compressor Power Adjustment

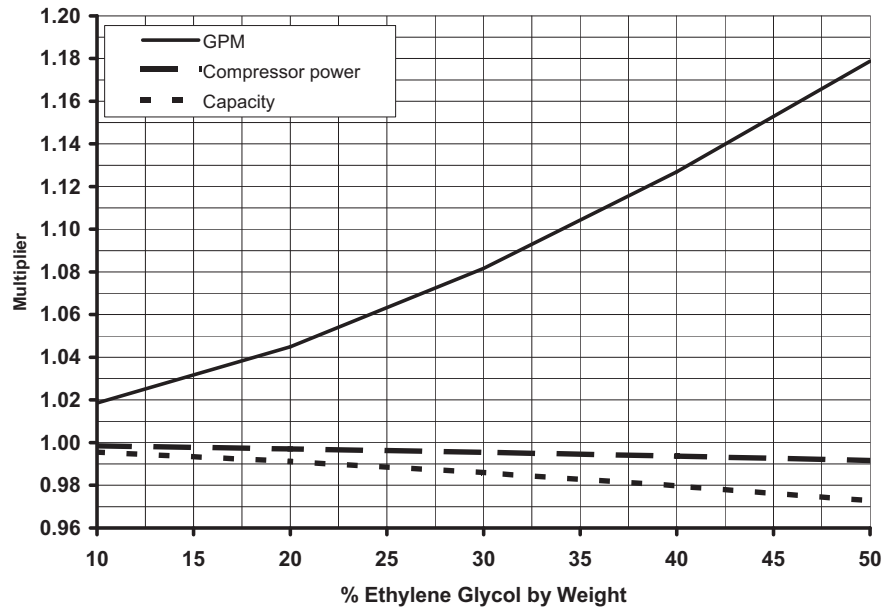
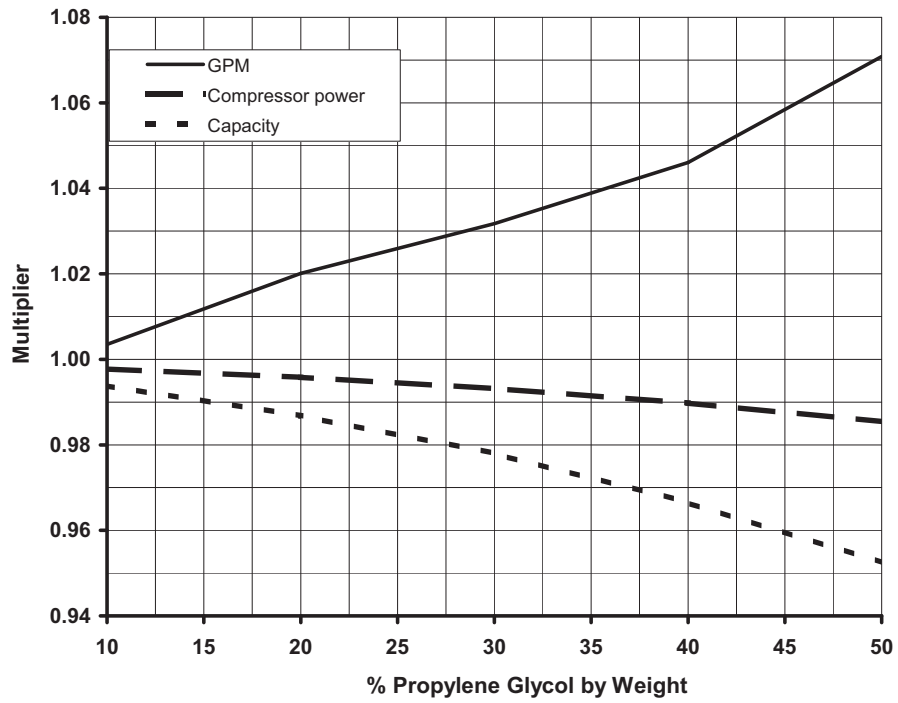


Figure 22. Remote EVP Propylene Glycol GPM, Capacity, and Compressor Power Adjustment





Controls

Standard Options 20 to 120-Ton Condensing Units

System Control Options

Select one of the following control options to meet your application requirements.

- **No System Control** provides the compressors wired to a terminal strip inside the control panel. The temperature controller must be field provided and installed. The 20, 25 and 30-ton have two capacity steps. The 40, 50 and 60-ton sizes have four steps available. The 80, 100, and 120-ton sizes have six steps available.
- **Constant Volume Control (20 to 60-Ton Models)** includes a W973 controller with two cool, four heat steps on the 20, 25 and 30-ton sizes. Four cool, four heat steps are provided on the 40, 50 and 60-ton sizes. The heating contacts are wired to terminals in the condensing unit control panel for easy interface with a field supplied electric duct heater or gas duct furnace. An optional return air sensor is available with this controller which provides the zone temperature input to the thermostat, thus generating the loading demand signal to the Honeywell W973 constant volume controller.
- **EVP Chiller Control** consists of an interface panel in the main unit control box and a remote mounted control box that is customer installed. The remote mounted box contains the Honeywell W7100G controller. The water chiller controller has an adjustable 0-10°F control band using integrating logic, built-in fixed-off timers and field installed discharge water temperature sensors for control and chiller freeze protection. Pumpdown is provided. Lead-lag and multiple chiller control are not provided. There are two capacity steps on 20, 25 and 30-ton sizes, four capacity steps on 40, 50 and 60 ton sizes and six capacity steps on 80, 100 and 120-ton sizes.
- **Supply Air VAV Control** provides a Honeywell W7100A control system. This option is for use with shut-off VAV or other applications requiring control of supply air temperature. The control provides a voltage output for interface with field supplied components to provide simultaneous economizer operation. The discharge air sensor ships with the unit for field mounting. The standard VAV unit is provided with reliable coil frost protection in the form of Trane's proven and patented FROSTAT™. FROSTAT is used in place of hot gas bypass.

Low Ambient Control Option

- **Standard** — Unit start-up and operation down to approximately 40°F at minimum compressor load.
- **Low Ambient** — Factory-installed head pressure control damper assembly permits operation down to 0°F by maintaining proper head pressure. Ten minute timer is standard for protection against nuisance trips.

Miscellaneous Options

Select the miscellaneous options to meet your project requirements.

- **Non-Fused Unit Disconnect Switch (20 to 60-Ton Models)** is mounted in the control box and provides for interruption of power for servicing the unit. Lugs are suitable for copper wires only. No overcurrent or short circuit protection is provided for the unit by this switch.
- **Hot Gas Bypass Valves** are stocked and shipped with the unit for field installation. When suction pressure falls below the valve adjustable set point, the valve modulates hot gas to the inlet of the evaporator.

Note: FROSTAT is standard on VAV units and is recommended in place of hot gas bypass.

Electrical Data

Table 7. Condensing units — 60 Hz

Nominal Tons	Model Number	Voltage/Start Characteristics	Unit Characteristics				
			Allowable Voltage Utilization Range	Minimum Circuit Ampacity ^{(a),(b)}	Max. Overcurrent Protection Device ^{(c),(b)}	Recommended Dual Element Fuse Size ^{(d),(b)}	Number Of Compressors
20	RAUJ-C20E	200/60/3/XL	180-220	102	125	125	2
	RAUJ-C20F	230/60/3/XL	207-253	89	110	100	2
	RAUJ-C204	460/60/3/XL	414-506	46	60	60	2
	RAUJ-C205	575/60/3/XL	517-633	39	50	45	2
25	RAUJ-C25E	200/60/3/XL	180-220	119	150	150	2
	RAUJ-C25F	230/60/3/XL	207-253	107	150	125	2
	RAUJ-C254	460/60/3/XL	414-506	52	70	60	2
	RAUJ-C255	575/60/3/XL	517-633	44	60	50	2
30	RAUJ-C30E	200/60/3/XL	180-220	141	175	175	2
	RAUJ-C30F	230/60/3/XL	207-253	123	150	150	2
	RAUJ-C304	460/60/3/XL	414-506	63	80	70	2
	RAUJ-C305	575/60/3/XL	517-633	57	70	70	2
40	RAUJ-C40E	200/60/3/XL	180-220	193	225	225	4
	RAUJ-C40F	230/60/3/XL	207-253	168	200	200	4
	RAUJ-C404	460/60/3/XL	414-506	87	100	100	4
	RAUJ-C405	575/60/3/XL	517-633	73	80	80	4
50	RAUJ-C50E	200/60/3/XL	180-220	236	250	250	4
	RAUJ-C50F	230/60/3/XL	207-253	215	250	250	4
	RAUJ-C504	460/60/3/XL	414-506	102	110	110	4
	RAUJ-C505	575/60/3/XL	517-633	86	100	100	4
60	RAUJ-C60E	200/60/3/XL	180-220	267	300	300	4
	RAUJ-C60F	230/60/3/XL	207-253	232	250	250	4
	RAUJ-C604	460/60/3/XL	414-506	120	125	125	4
	RAUJ-C605	575/60/3/XL	517-633	107	125	125	4
80	RAUJ-C80E	200/60/3/XL	180-220	411	450	450	6
	RAUJ-C80F	230/60/3/XL	207-253	358	400	400	6
	RAUJ-C804	460/60/3/XL	414-506	174	175	175	6
	RAUJ-C805	575/60/3/XL	517-633	139	150	150	6
100	RAUJ-D10E	200/60/3/XL	180-220	480	500	500	6
	RAUJ-D10F	230/60/3/XL	207-253	425	450	450	6
	RAUJ-D104	460/60/3/XL	414-506	207	225	225	6
	RAUJ-D105	575/60/3/XL	517-633	166	175	175	6
120	RAUJ-D12E	200/60/3/XL	180-220	574	600	600	6
	RAUJ-D12F	230/60/3/XL	207-253	515	600	600	6
	RAUJ-D124	460/60/3/XL	414-506	255	300	300	6
	RAUJ-D125	575/60/3/XL	517-633	204	225	225	6

(a) Minimum circuit ampacity (MCA) is 125 percent of the RLA of one compressor motor plus the total RLA of the remaining motors.

(b) Local codes may take precedence.

(c) Maximum Overcurrent Protection Device permitted by NEC 440-22 is 225 percent of the RLA of one compressor motor plus the total RLA of the remaining motors.

(d) Recommended dual element fuse size is 150 percent of the RLA of one compressor motor plus the total RLA of the remaining motors.



Electrical Data

Table 8. Compressor motor and condenser fan data — 60 Hz

Nominal Tons	Model	Voltage	Compressor 1A ^(a)		Compressor 1B		Compressor 2A		Compressor 2B		Condenser Fans	
			RLA	LRA	RLA	LRA	RLA	LRA	RLA	LRA	Qty.	FLA
20	RAUJ-C20	200 XL	41.4	267.0	41.4	267.0	-	-	-	-	2	4.1
		230 XL	35.5	267.0	35.5	267.0	-	-	-	-	2	4.1
		460 XL	18.6	142.0	18.6	142.0	-	-	-	-	2	1.8
		575 XL	15.8	103.0	15.8	103.0	-	-	-	-	2	1.4
25	RAUJ-C25	200 XL	41.4	267.0	52.0	315.0	-	-	-	-	3	4.1
		230 XL	35.5	267.0	46.9	315.0	-	-	-	-	3	4.1
		460 XL	18.6	142.0	22.2	158.0	-	-	-	-	3	1.8
		575 XL	15.8	103.0	19.2	136.0	-	-	-	-	3	1.4
30	RAUJ-C30	200 XL	56.9	351.0	56.9	351.0	-	-	-	-	3	4.1
		230 XL	48.8	351.0	48.8	351.0	-	-	-	-	3	4.1
		460 XL	25.5	197.0	25.5	197.0	-	-	-	-	3	1.8
		575 XL	23.1	146.0	23.1	146.0	-	-	-	-	3	1.4
40	RAUJ-C40	200 XL	41.4	267.0	41.4	267.0	41.4	267.0	41.4	267.0	4	4.1
		230 XL	35.5	267.0	35.5	267.0	35.5	267.0	35.5	267.0	4	4.1
		460 XL	18.6	142.0	18.6	142.0	18.6	142.0	18.6	142.0	4	1.8
		575 XL	15.8	103.0	15.8	103.0	15.8	103.0	15.8	103.0	4	1.4
50	RAUJ-C50	200 XL	47.0	304.0	52.0	315.0	47.0	304.0	52.0	315.0	6	4.1
		230 XL	42.3	304.0	46.9	315.0	42.3	304.0	46.9	315.0	6	4.1
		460 XL	20.2	158.0	22.2	158.0	20.2	158.0	22.2	158.0	6	1.8
		575 XL	17.1	136.0	19.2	136.0	17.1	136.0	19.2	136.0	6	1.4
60	RAUJ-C60	200 XL	56.9	351.0	56.9	351.0	56.9	351.0	56.9	351.0	6	4.1
		230 XL	48.8	351.0	48.8	351.0	48.8	351.0	48.8	351.0	6	4.1
		460 XL	25.5	197.0	25.5	197.0	25.5	197.0	25.5	197.0	6	1.8
		575 XL	23.1	146.0	23.1	146.0	23.1	146.0	23.1	146.0	6	1.4
Nominal Tons	Model	Voltage	Compressors 1A/2A ^(b)		Compressors 1B/2B		Compressors 1C/2C		Condenser Fans			
			FLA	RLA	FLA	RLA	FLA	RLA	Qty.	FLA		
80	RAUJ-C80	200 XL	60.5	320.0	60.5	320.0	60.5	320.0	-	-	8	4.1
		230 XL	52.0	320.0	52.0	320.0	52.0	320.0	-	-	8	4.1
		460 XL	25.4	160.0	25.4	160.0	25.4	160.0	-	-	8	1.8
		575 XL	20.3	135.0	20.3	135.0	20.3	135.0	-	-	8	1.4
100	RAUJ-D10	200 XL	60.5	320.0	60.5	320.0	83.9	485.0	-	-	12	4.1
		230 XL	52.0	320.0	52.0	320.0	74.5	485.0	-	-	12	4.1
		460 XL	25.4	160.0	25.4	160.0	37.2	215.0	-	-	12	1.8
		575 XL	20.3	135.0	20.3	135.0	29.8	175.0	-	-	12	1.4
120	RAUJ-D12	200 XL	83.9	485	83.9	485	83.9	485.0	-	-	12	4.1
		230 XL	74.5	485	74.5	485	74.5	485.0	-	-	12	4.1
		460 XL	37.2	215	37.2	215	37.2	215.0	-	-	12	1.8
		575 XL	29.8	175	29.8	175	29.8	175.0	-	-	12	1.4

(a) Value given is per compressor on 20-60 ton units.

(b) For 80 to 120-ton units, electrical values shown are for each compressor.

Table 9. Condensing units — 50 Hz

Unit Characteristics							
Nominal Tons	Model Number	Voltage/Start Characteristics	Allowable Voltage Utilization Range	Minimum Circuit Ampacity ^(a) , ^(b)	Max. Overcurrent Protection Device ^{(c),(b)}	Recommended Dual Element Fuse Size ^{(d),(b)}	Number Of Compressors
20	RAUJ-C209/D	380/415/50/3/XL	360-440	46	60	60	2
25	RAUJ-C259/D	380/415/50/3/XL	360-440	52	70	60	2
30	RAUJ-C309/D	380/415/50/3/XL	360-440	63	80	70	2
40	RAUJ-C409/D	380/415/50/3/XL	360-440	86	100	100	4
50	RAUJ-C509/D	380/415/50/3/XL	360-440	101	110	110	4
60	RAUJ-C609/D	380/415/50/3/XL	360-440	119	125	125	4
80	RAUJ-C809/D	380/415/50/3/XL	360-440	173	175	175	6
100	RAUJ-D109/D	380/415/50/3/XL	360-440	206	225	225	6
120	RAUJ-D129/D	380/415/50/3/XL	360-440	253	300	300	6

- (a) Minimum circuit ampacity (MCA) is 125 percent of the RLA of one compressor motor plus the total RLA of the remaining motors.
 (b) Local codes may take precedence.
 (c) Maximum Overcurrent Protection Device permitted by NEC 440-22 is 225 percent of the RLA of one compressor motor plus the total RLA of the remaining motors.
 (d) Recommended dual element fuse size is 150 percent of the RLA of one compressor motor plus the total RLA of the remaining motors.

Table 10. Compressor motor and condenser fan data — 50 Hz

Nominal Tons	Model	Voltage	Compressor 1A ^(a)		Compressor 1B		Compressor 2A		Compressor 2B		Condenser Fans	
			RLA	LRA	RLA	LRA	RLA	LRA	RLA	LRA	Qty.	FLA
20	RAUJ-C20	380/415 XL	18.6	142	18.6	142	-	-	-	-	2	1.7
25	RAUJ-C25	380/415 XL	18.6	142	22.2	158	-	-	-	-	3	1.7
30	RAUJ-C30	380/415 XL	25.5	146	25.5	146	-	-	-	-	3	1.7
40	RAUJ-C40	380/415 XL	18.6	142	18.6	142	18.6	142	18.6	142	4	1.7
50	RAUJ-C50	380/415 XL	20.2	158	22.2	158	20.2	158	22.2	158	6	1.7
60	RAUJ-C60	380/415 XL	25.5	146	25.5	146	25.5	146	25.5	146	6	1.7
Nominal Tons	Model	Voltage	Compressors 1A/2A ^(b)		Compressors 1B/2B		Compressors 1C/2C				Condenser Fans	
			FLA	RLA	FLA	RLA	FLA	RLA			Qty.	FLA
80	RAUJ-C80	380/415 XL	25.4	160	25.4	160	25.4	160	-	-	8	1.7
100	RAUJ-D10	380/415 XL	25.4	160	25.4	160	37.2	215	-	-	12	1.7
120	RAUJ-D12	380/415 XL	37.2	215	37.2	215	37.2	215	-	-	12	1.7

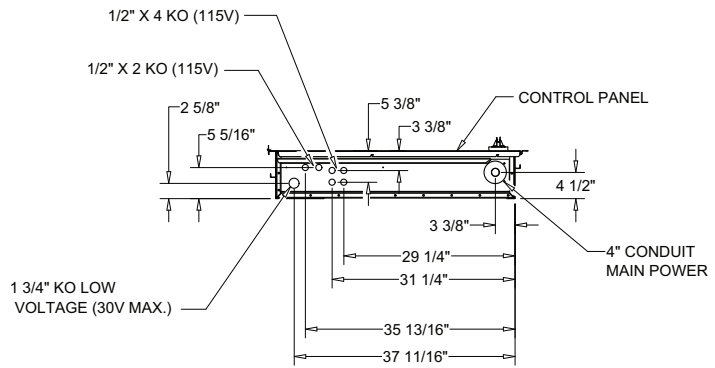
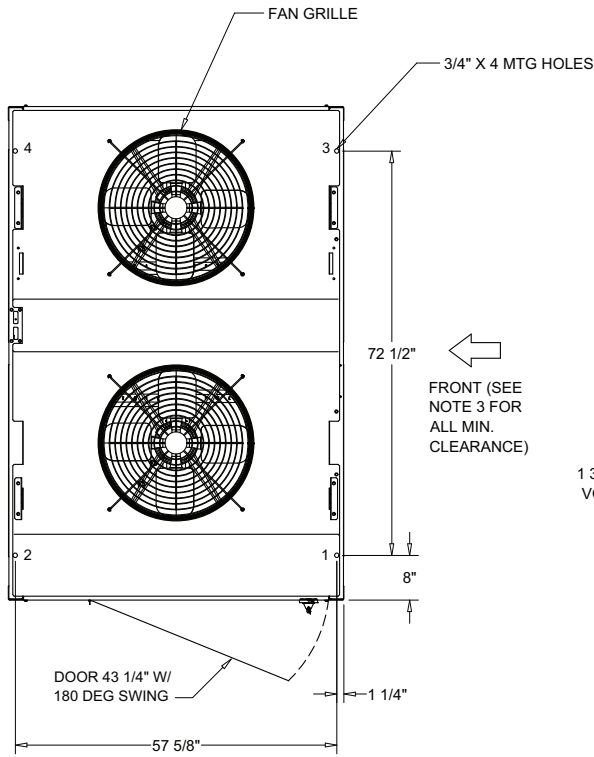
- (a) Value given is per compressor on 20-60 ton units.
 (b) For 80 to 120-ton units, electrical values shown are for each compressor.

Dimensional Data

Figure 23. 20-Ton air-cooled condensing unit

NOTES:

1. SEE CONNECTION DRAWING FOR CONNECTION LOCATION AND SIZES.
2. LOW AMBIENT DAMPER ONLY COMES WITH SELECTED UNIT.
3. FRONT OF UNIT CLEARANCE 72" . BACK OF UNIT CLEARANCE 48" . LEFT AND RIGHT SIDE OF UNIT CLEARANCE 42".



DETAIL A

CONTROL BOX BOTTOM

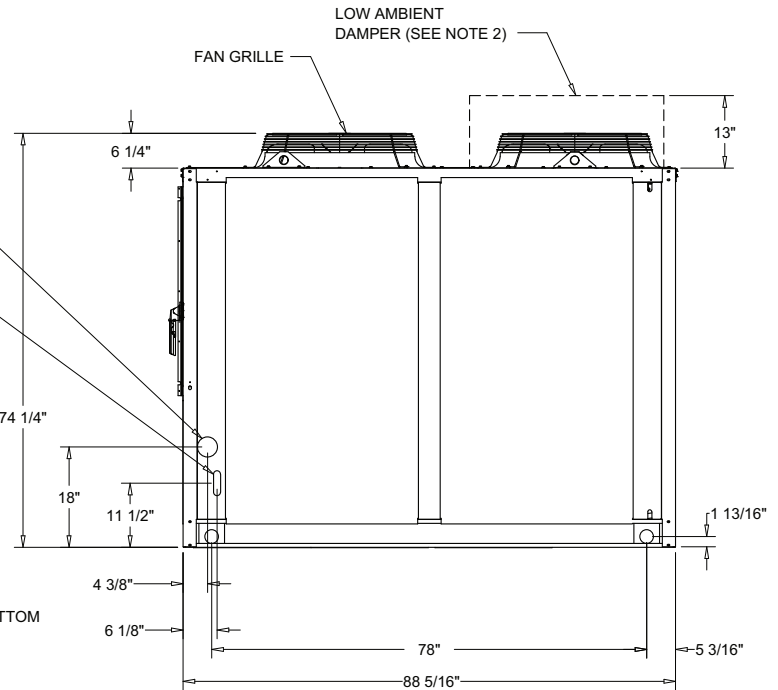
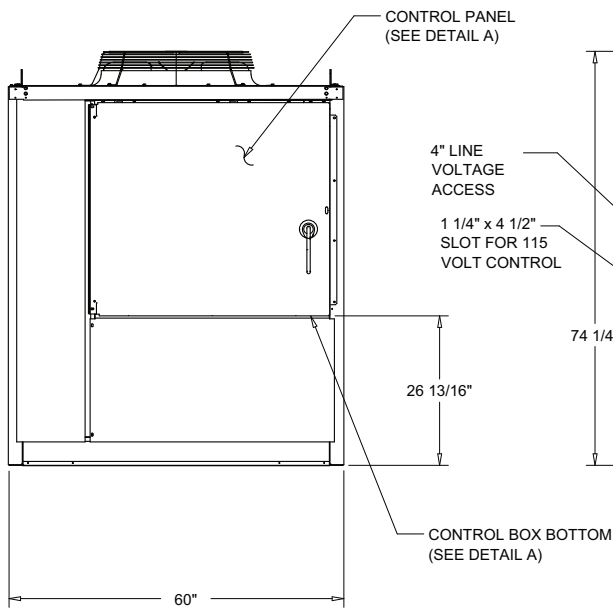
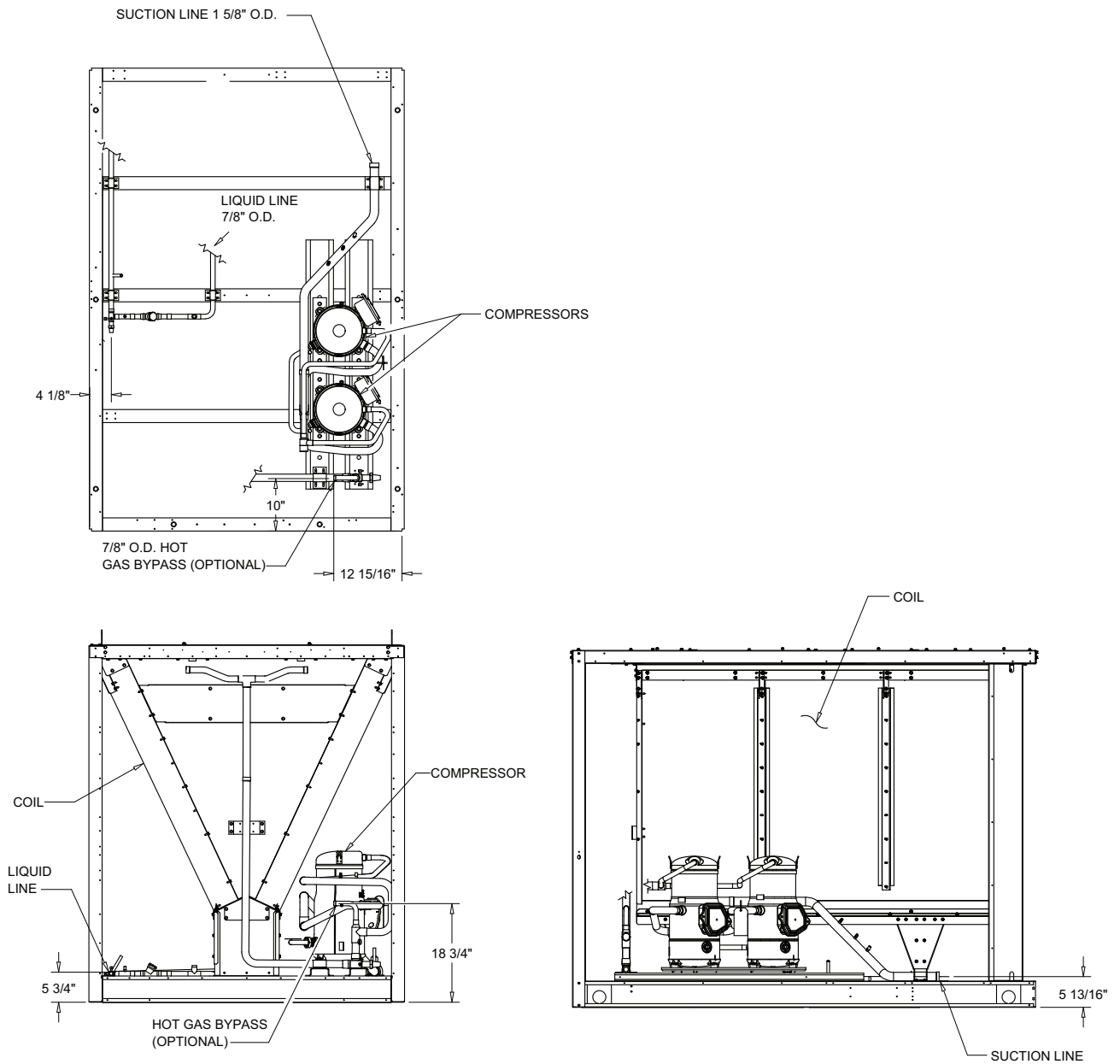


Figure 24. 20-Ton air-cooled condensing unit (connections)

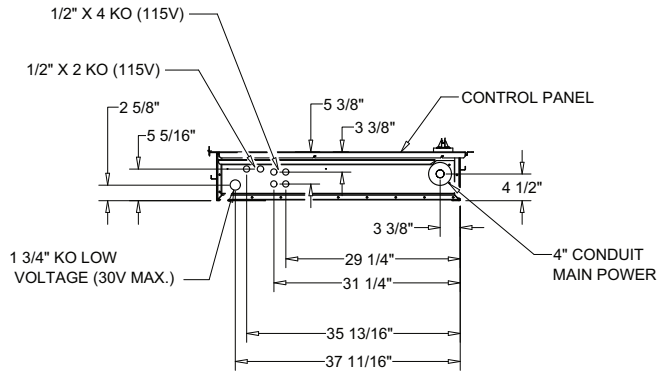
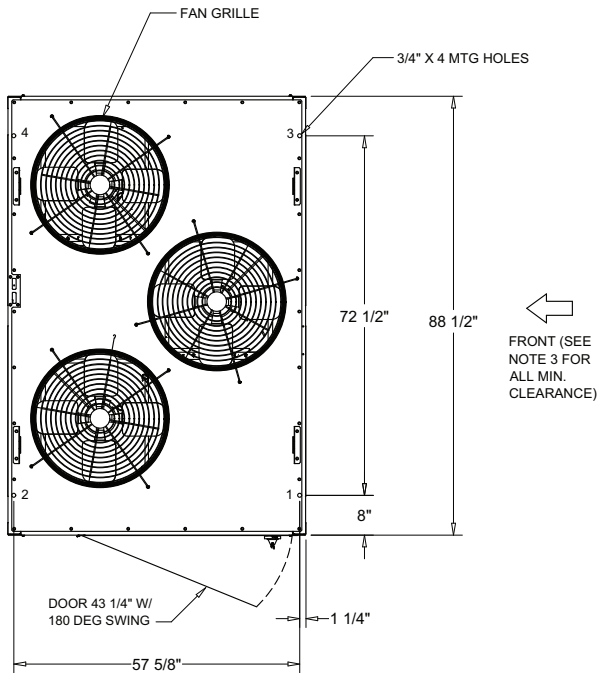


Dimensional Data

Figure 25. 25- and 30-Ton air-cooled condensing unit

NOTES:

1. SEE CONNECTION DRAWING FOR CONNECTION LOCATION AND SIZES.
2. LOW AMBIENT DAMPER ONLY COMES WITH SELECTED UNIT .
3. FRONT OF 20 AND 30 UNIT CLEARANCE 72" . BACK OF 20 UNIT CLEARANCE 48" . BACK OF 30 UNIT CLEARANCE 72" . LEFT AND RIGHT SIDE OF 20 AND 30 UNIT CLEARANCE 42".



DETAIL A

CONTROL BOX BOTTOM

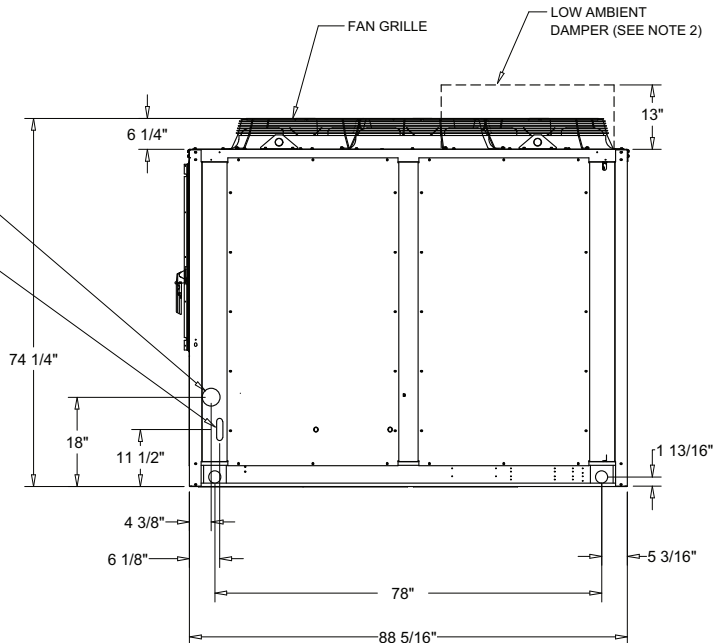
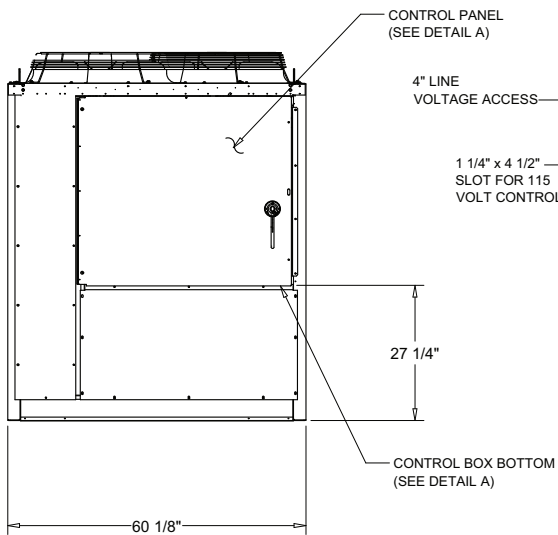
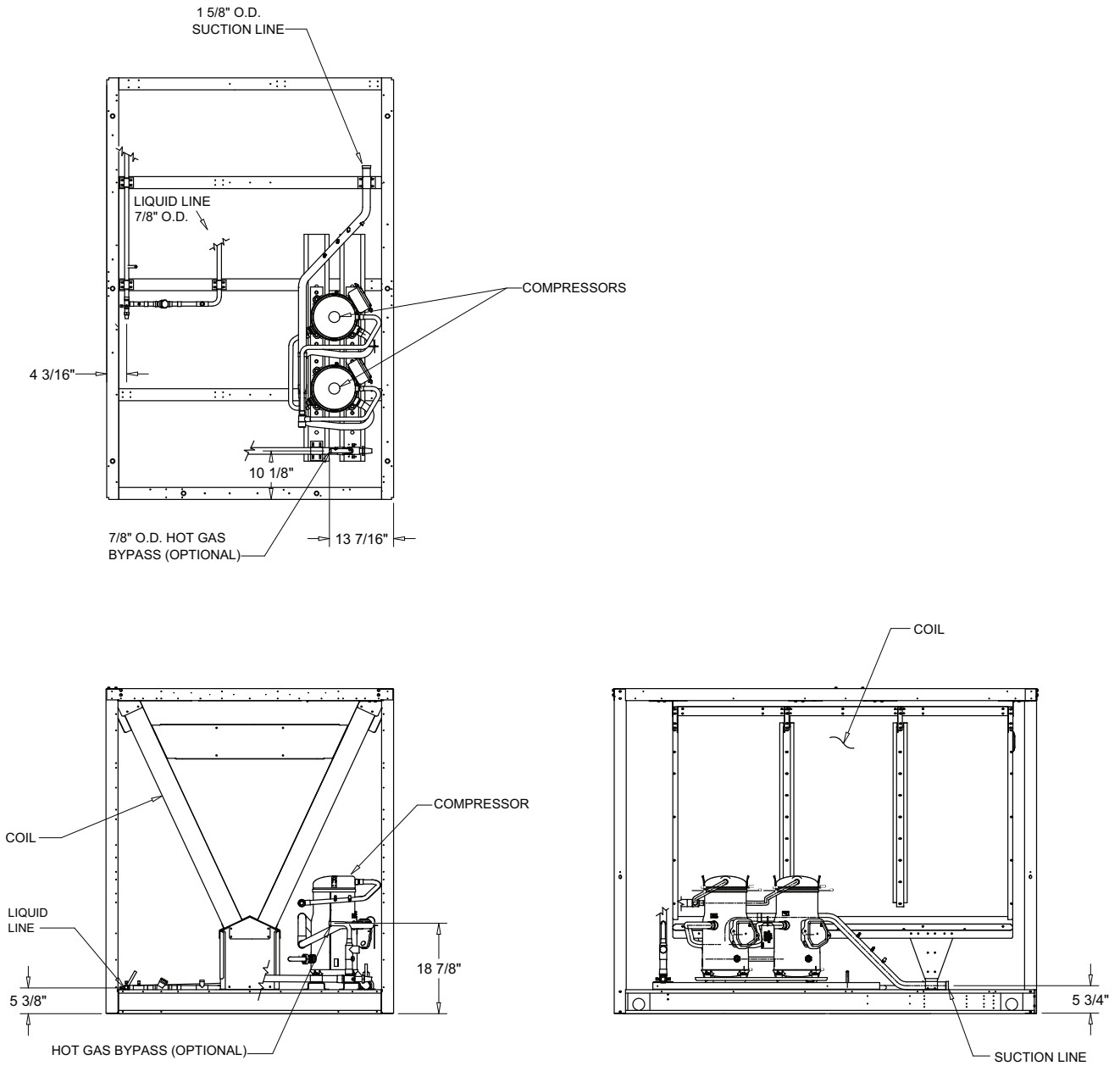
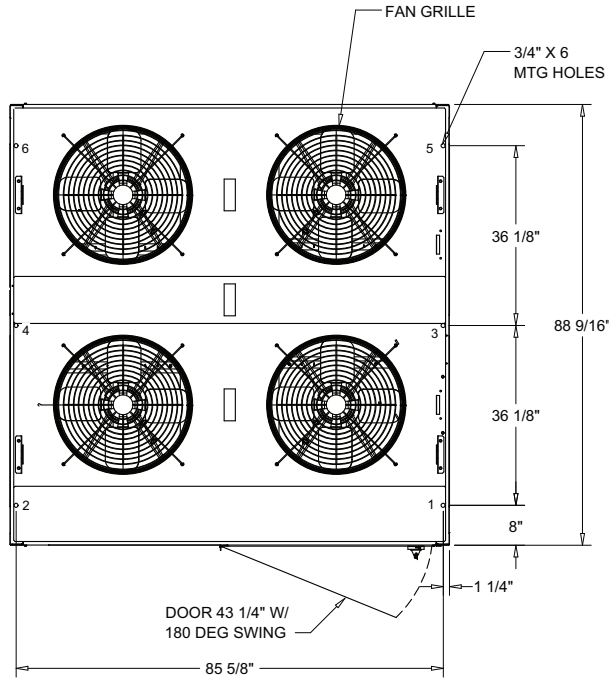


Figure 26. 25- and 30-Ton air-cooled condensing unit (connections)



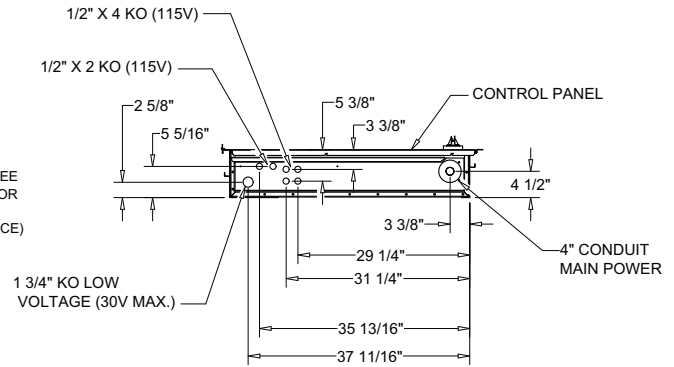
Dimensional Data

Figure 27. 40-Ton air-cooled condensing unit



NOTES:

1. SEE CONNECTION DRAWING FOR CONNECTION LOCATION AND SIZES.
2. LOW AMBIENT DAMPER ONLY COMES WITH SELECTED UNIT .
3. FRONT AND BACK OF UNIT CLEARANCE 72" . LEFT AND RIGHT SIDE OF UNIT CLEARANCE 42".



DETAIL A

BOTTOM OF CONTROL BOX

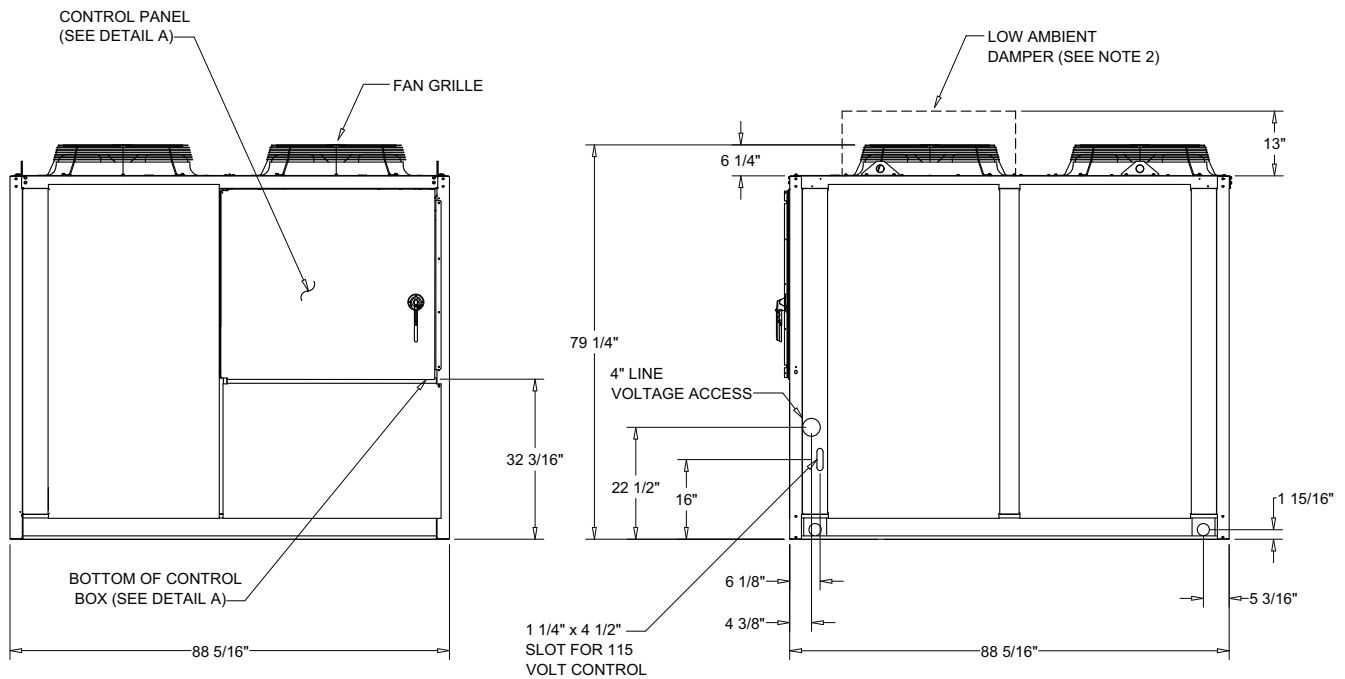
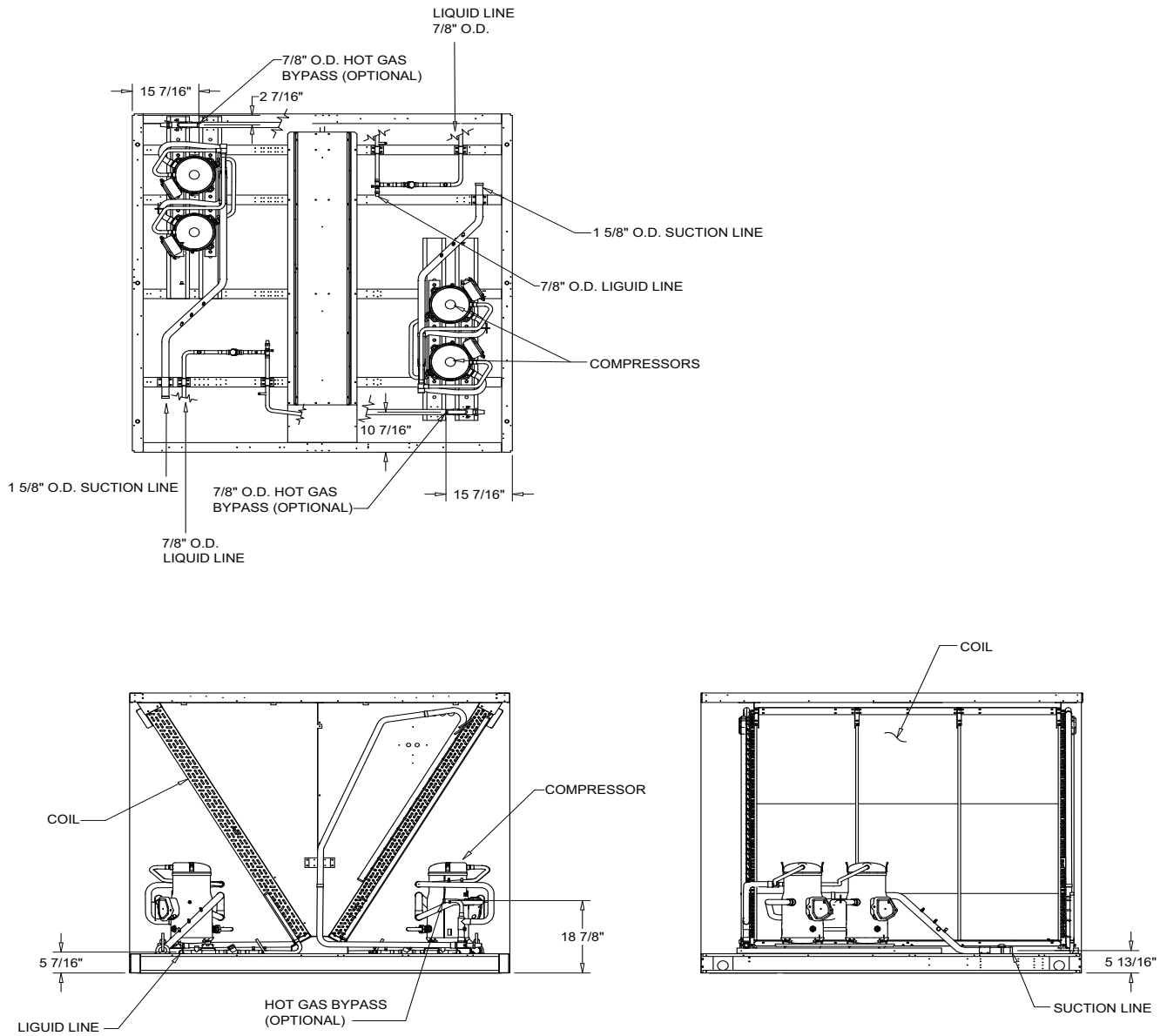


Figure 28. 40-Ton air-cooled condensing unit (connections)



Dimensional Data

Figure 29. 50-Ton air-cooled condensing unit

NOTES:

1. SEE CONNECTION DRAWING FOR CONNECTION LOCATION AND SIZES.
2. LOW AMBIENT DAMPER ONLY COMES WITH SELECTED UNIT .
3. FRONT AND BACK OF UNIT CLEARANCE 72" . LEFT AND RIGHT SIDE OF UNIT CLEARANCE 42" .

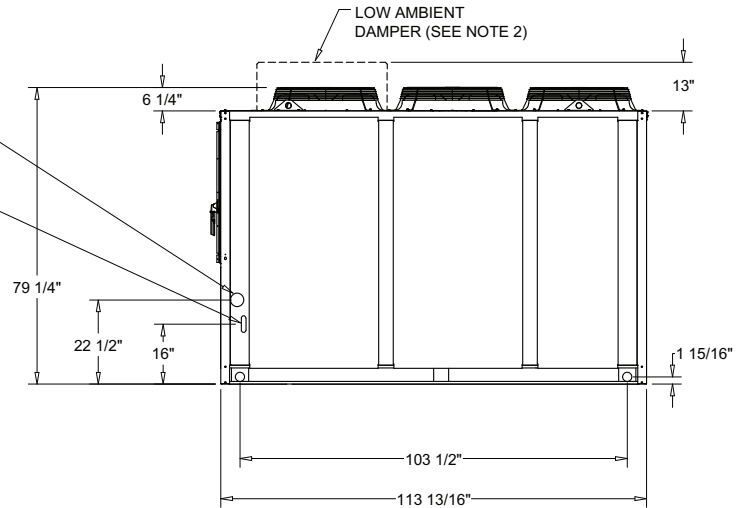
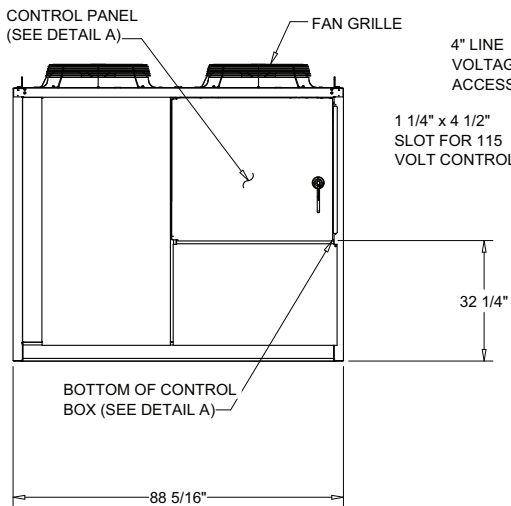
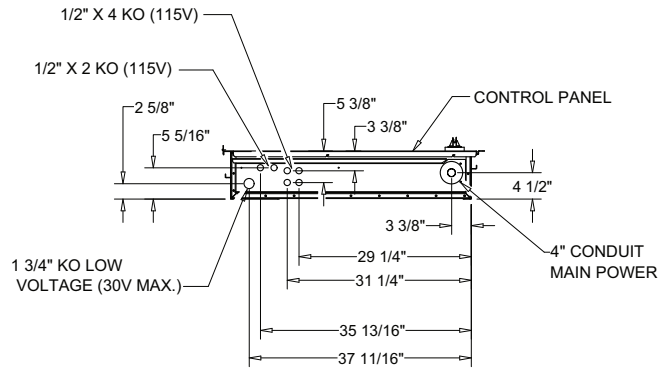
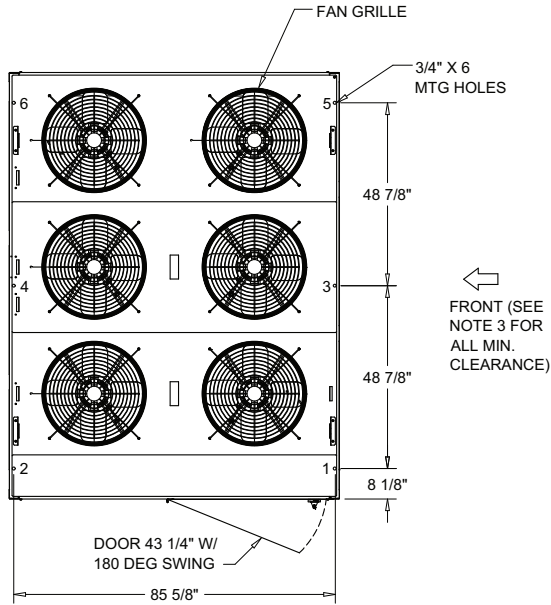
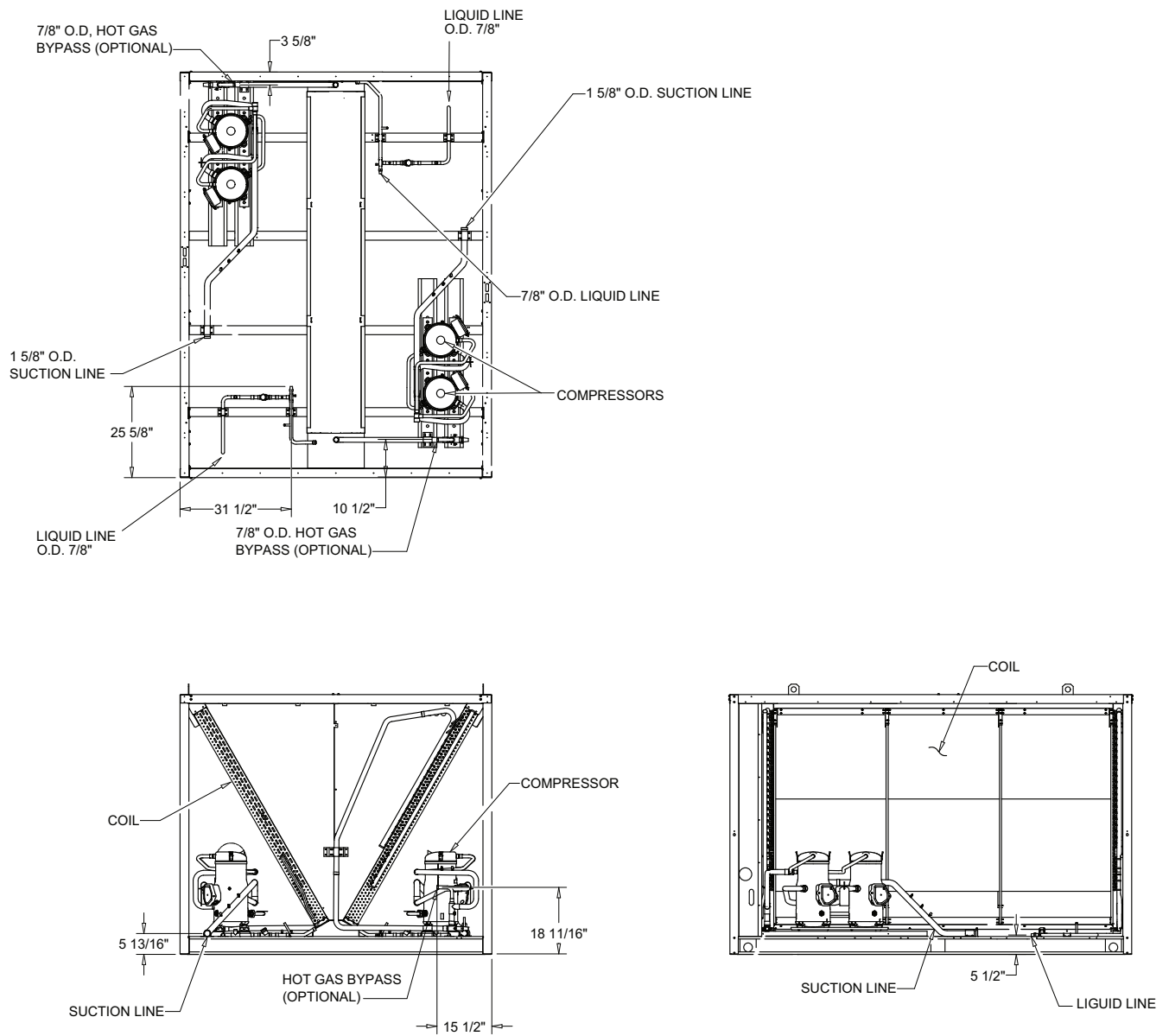


Figure 30. 50-Ton air-cooled condensing unit (connections)



Dimensional Data

Figure 31. 60-Ton air-cooled condensing unit

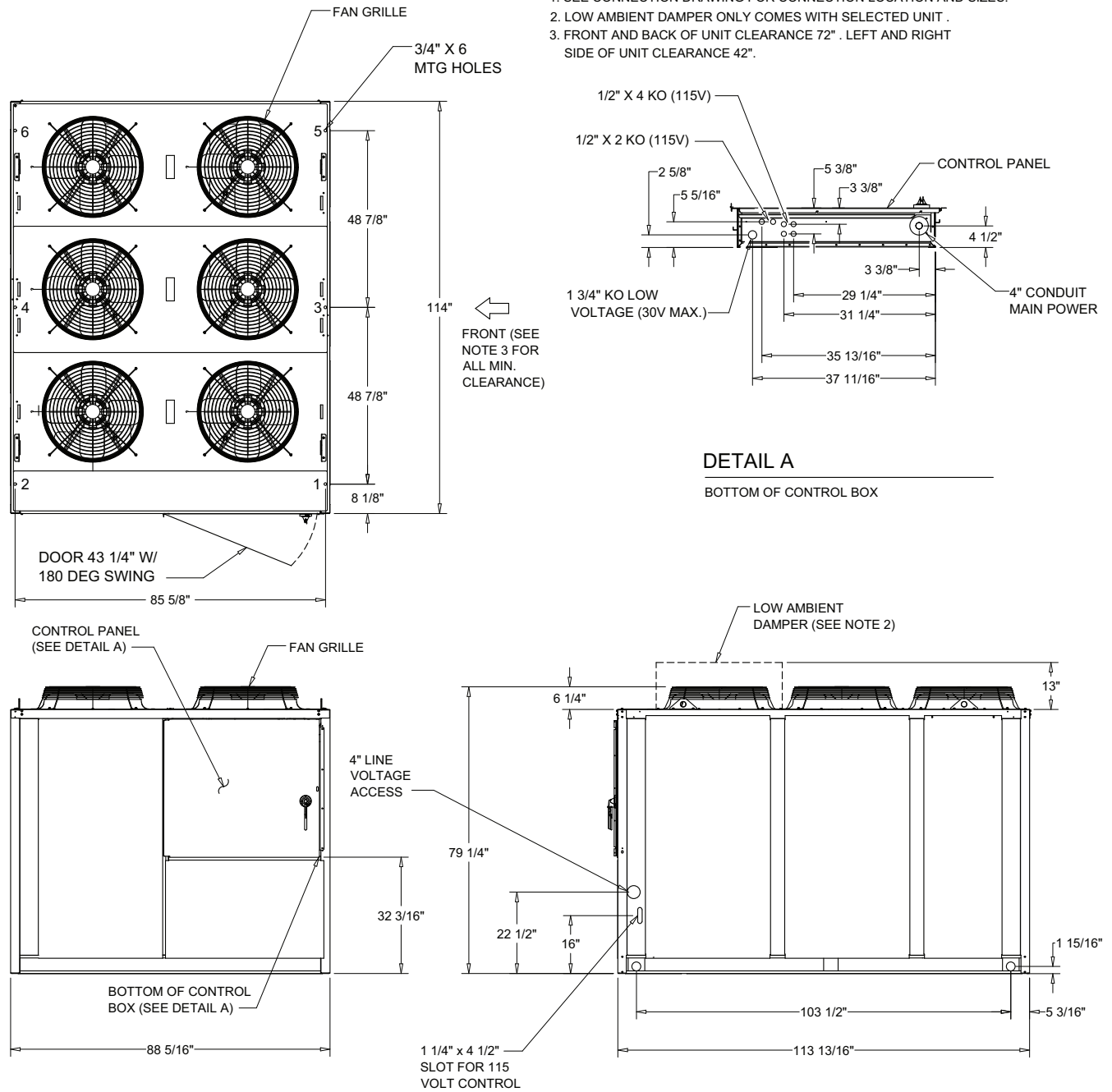
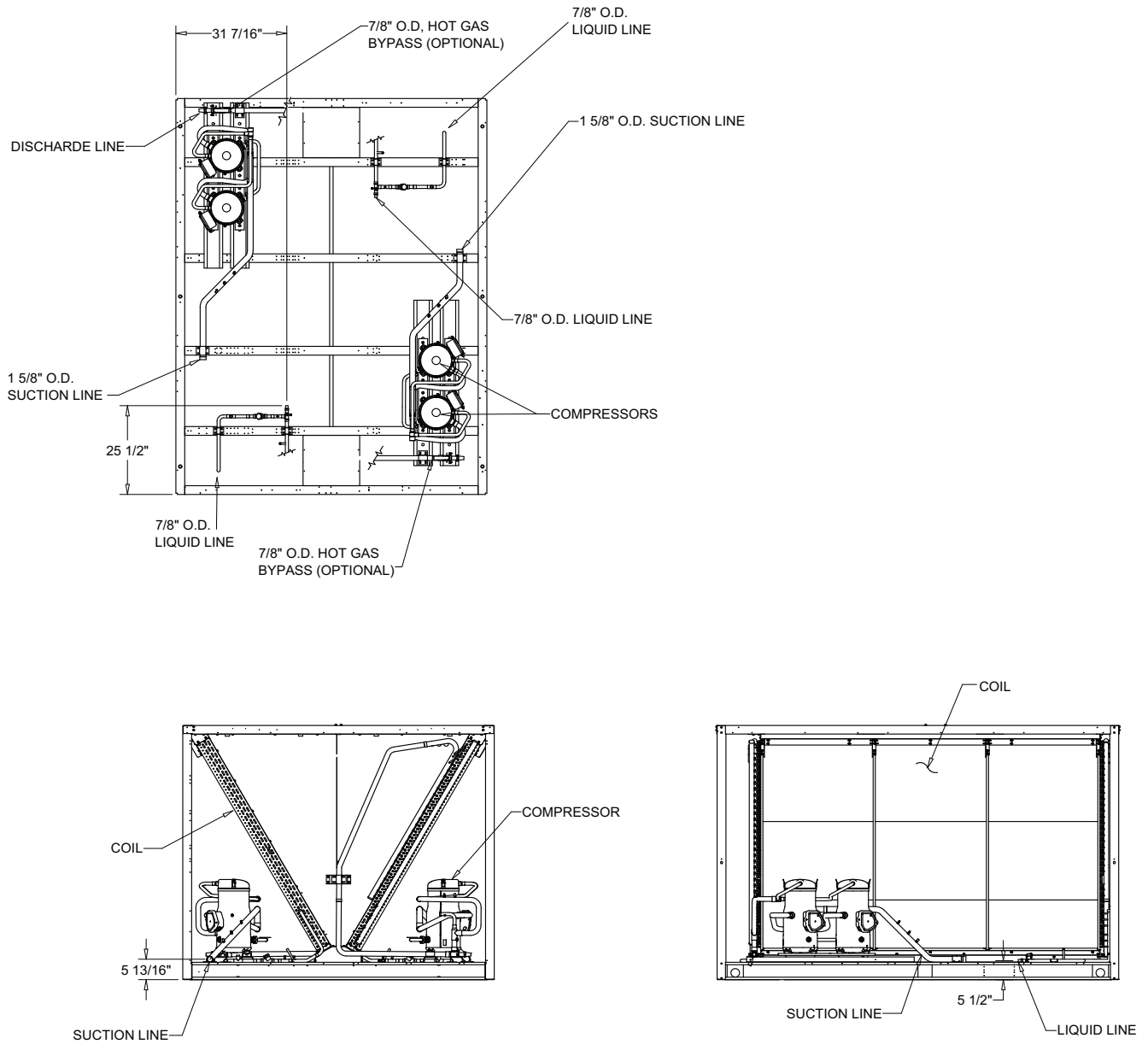
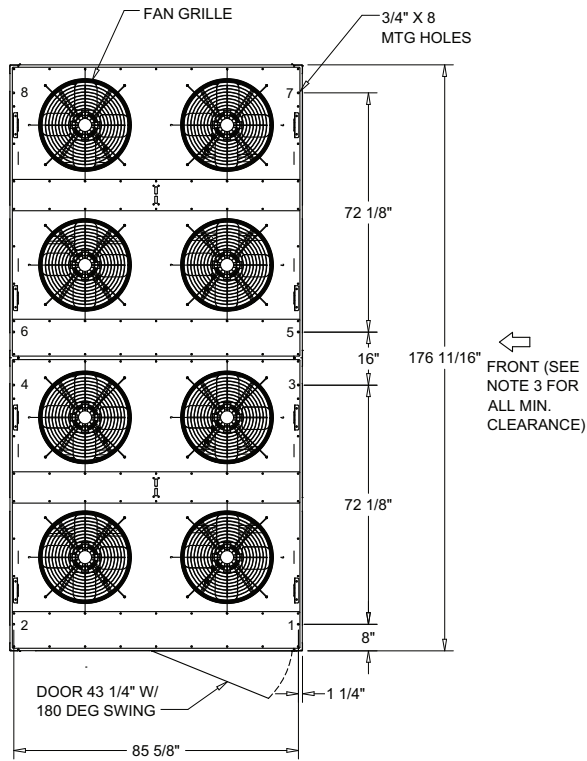


Figure 32. 60-Ton air-cooled condensing unit (connections)



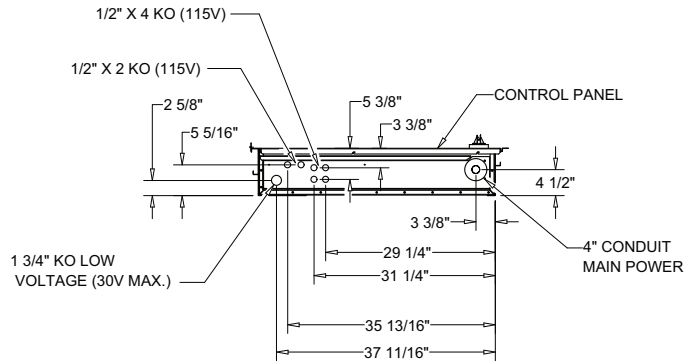
Dimensional Data

Figure 33. 80-Ton air-cooled condensing unit



NOTES:

1. SEE CONNECTION DRAWING FOR CONNECTION LOCATION AND SIZES.
2. LOW AMBIENT DAMPER ONLY COMES WITH SELECTED UNIT .
3. FRONT AND BACK OF UNIT CLEARANCE 96" . LEFT AND RIGHT SIDE OF UNIT CLEARANCE 48".



DETAIL A

DIMENSIONAL DETAIL

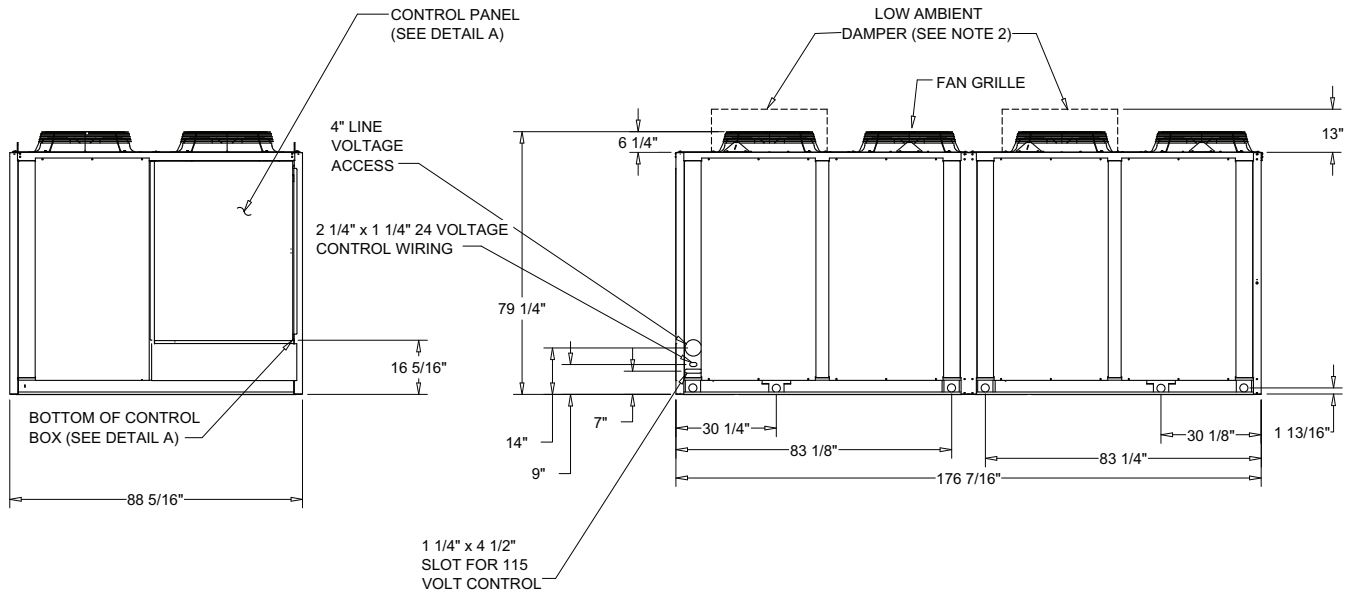


Figure 34. 80-Ton air-cooled condensing unit (connections)

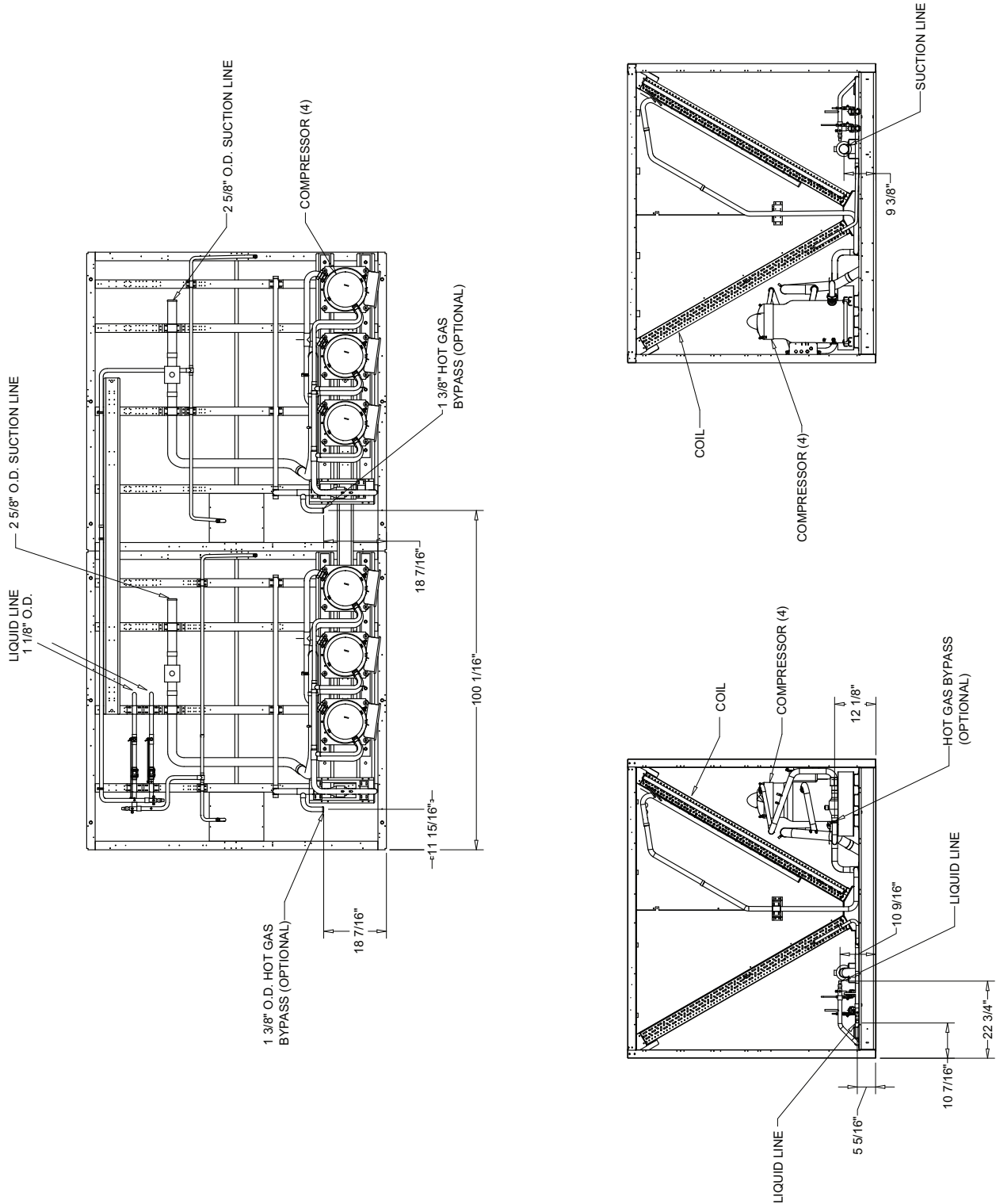
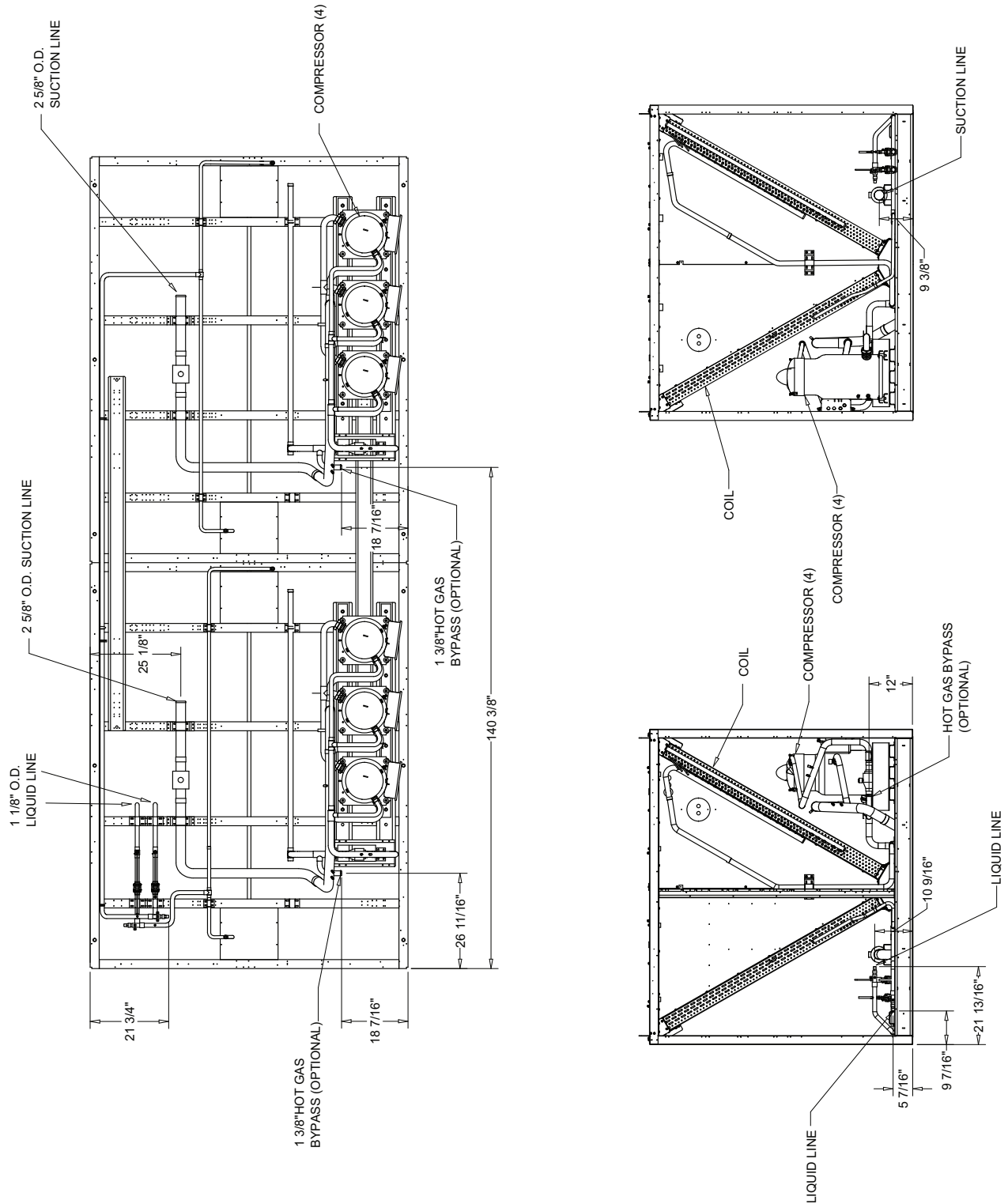


Figure 36. 100- and 120-Ton air-cooled condensing unit (connections)



Dimensional Data

Figure 37. 20-Ton Evaporator Chiller

Notes:
 THIS HEAT EXCHANGER IS INTENDED FOR INDOOR INSTALLATION ONLY
 HEAT EXCHANGER MOUNTING LEGS ARE INSTALLED AT JOB SITE WITH SUPPLIED FASTENERS (ITEM 4)
 INSULATION (ITEMS 5, 6, & 7) SHOULD BE INSTALLED AFTER INSTALLING LEGS & REFRIGERANT TUBING, DR MUST BE ADEQUATELY SHIELDED AGAINST HEAT WHEN BRAZING REFRIGERANT LINES
 INSTALL INSULATION SIDE PIECES FIRST (ITEMS 6 & 7), THEN WRAPPER (ITEM 5), ITEM 5 MAY REQUIRE TRIMMING
 USE VINYL TAPE (FIELD SUPPLIED) TO SEAL INSULATION AFTER INSTALLATION
 WATER CONNECTIONS ARE GROOVED (VICI TAUCILIC)
 REFRIGERANT CONNECTIONS ARE STAINLESS STEEL AND REQUIRE SPECIAL BRAZE MATERIALS. SEE IOM BRAZE PROCEDURES.

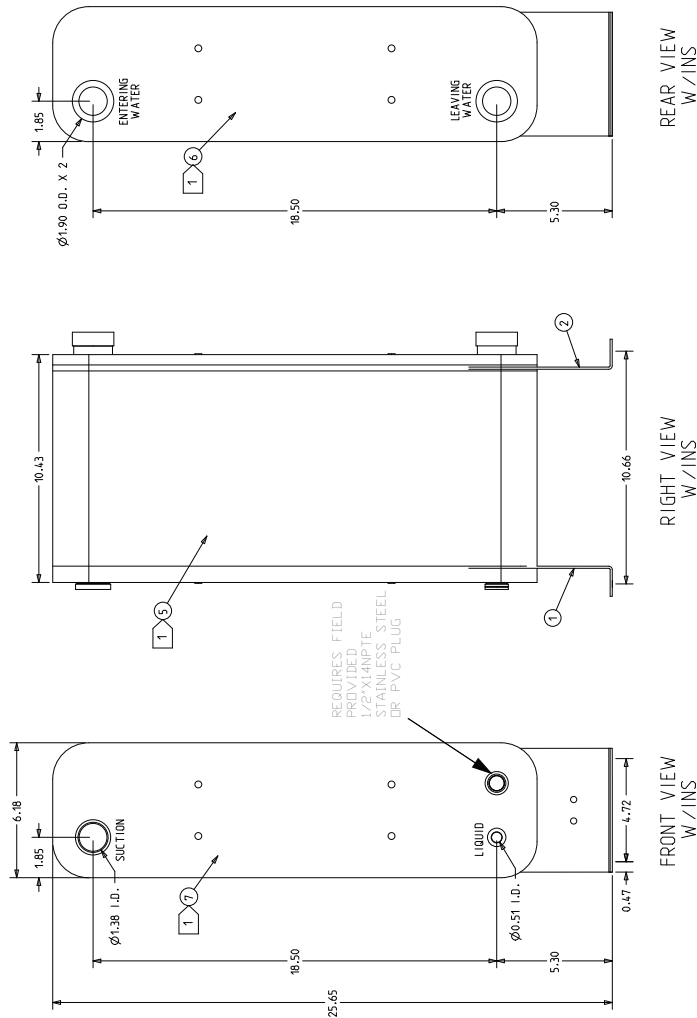
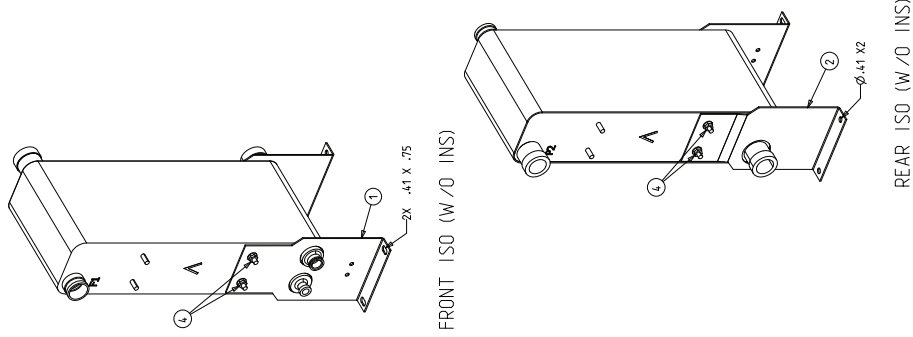
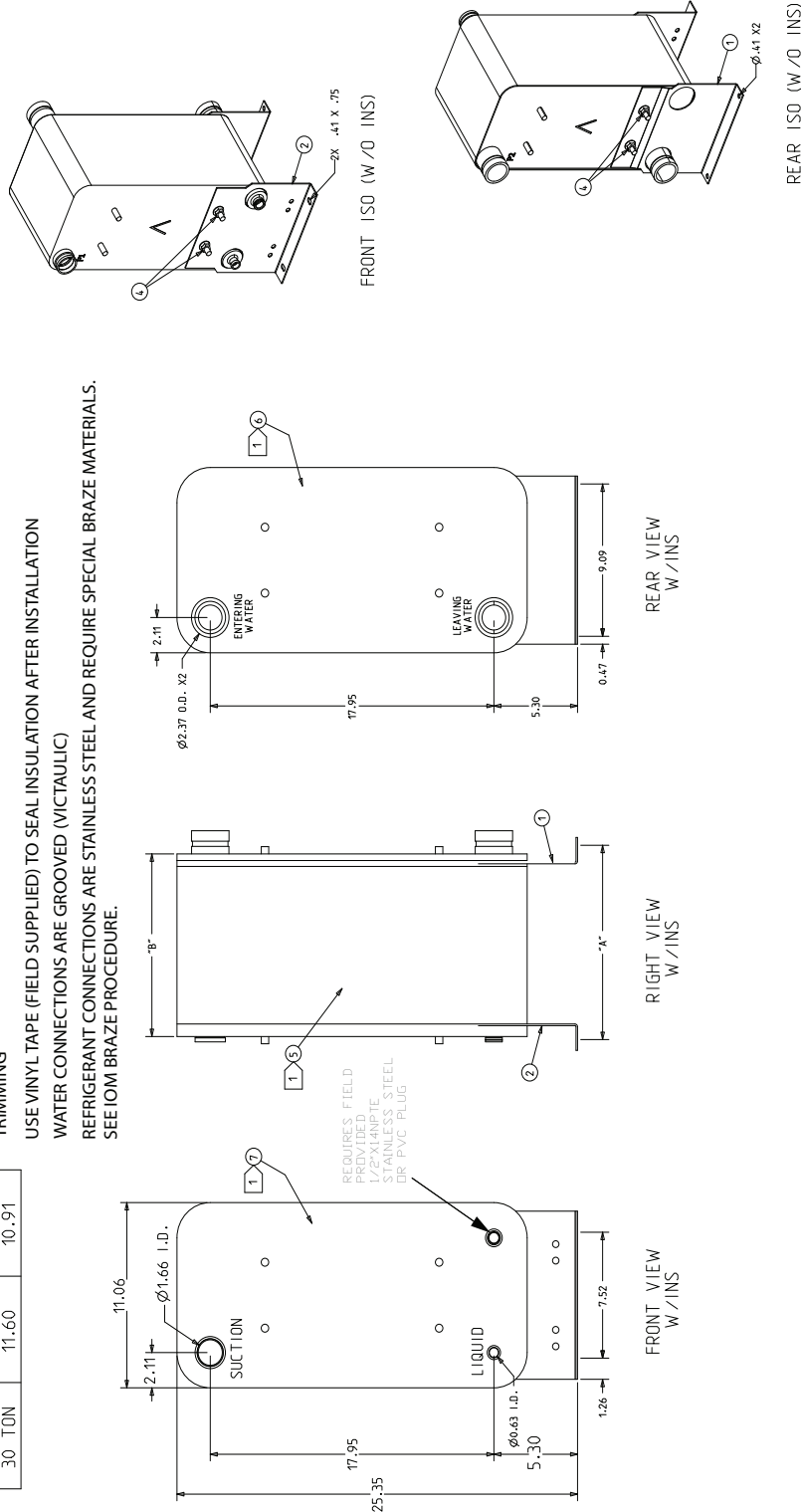


Figure 38. 25 and 30-Ton Evaporator Chiller

Notes:
 THIS HEAT EXCHANGER IS INTENDED FOR INDOOR INSTALLATION ONLY
 HEAT EXCHANGER MOUNTING LEGS ARE INSTALLED AT JOB SITE WITH SUPPLIED FASTENERS (ITEM 4)
 INSULATION (ITEMS 5, 6, & 7) SHOULD BE INSTALLED AFTER INSTALLING LEGS & REFRIGERANT TUBING, OR
 MUST BE ADEQUATELY SHIELDED AGAINST HEAT WHEN BRAZING REFRIGERANT LINES
 Install INSULATION SIDE PIECES FIRST (ITEMS 6 & 7), THEN WRAPPER (ITEM 5), ITEM 5 MAY REQUIRE
 TRIMMING
 USE VINYL TAPE (FIELD SUPPLIED) TO SEAL INSULATION AFTER INSTALLATION
 WATER CONNECTIONS ARE GROOVED (VICTAULIC)
 REFRIGERANT CONNECTIONS ARE STAINLESS STEEL AND REQUIRE SPECIAL BRAZE MATERIALS.
 SEE IOM BRAZE PROCEDURE.

TONNAGE	"A"	"B"
25 TON	8.75	8.02
30 TON	11.60	10.91



Dimensional Data

Figure 39. 40-Ton Evaporator Chiller

Notes:
 THIS HEAT EXCHANGER IS INTENDED FOR INDOOR INSTALLATION ONLY
 HEAT EXCHANGER MOUNTING LEGS ARE INSTALLED AT JOB SITE WITH SUPPLIED FASTENERS (ITEM 4)
 INSULATION (ITEMS 5, 6, & 7) SHOULD BE INSTALLED AFTER INSTALLING LEGS & REFRIGERANT
 TUBING, OR MUST BE ADEQUATELY SHIELDED AGAINST HEAT WHEN BRAZING REFRIGERANT LINES
 Install INSULATION SIDE PIECES FIRST (ITEMS 6 & 7), THEN WRAPPER (ITEM 5), ITEM 5 MAY
 REQUIRE TRIMMING
 USE VINYL TAPE (FIELD SUPPLIED) TO SEAL INSULATION AFTER INSTALLATION
 WATER CONNECTIONS ARE GROOVED (VICTAULIC)
 REFRIGERANT CONNECTIONS ARE STAINLESS STEEL AND REQUIRE SPECIAL BRAZE MATERIALS.
 SEE IOM BRAZE PROCEDURE.

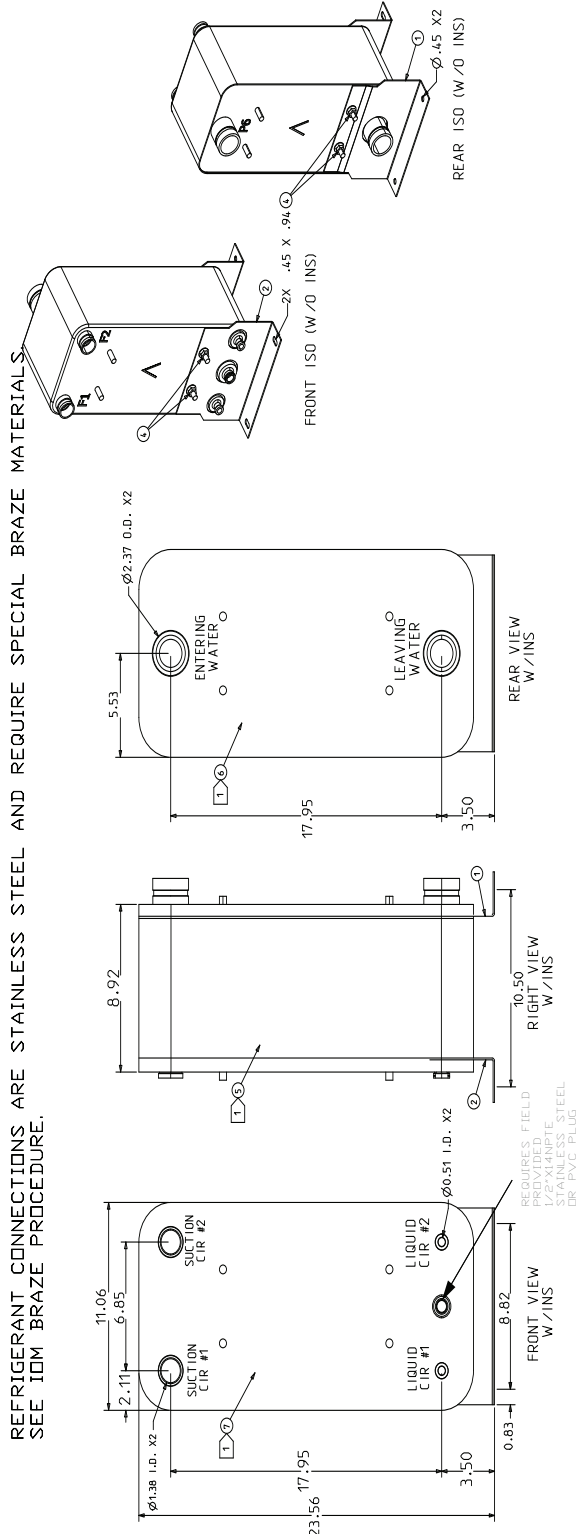
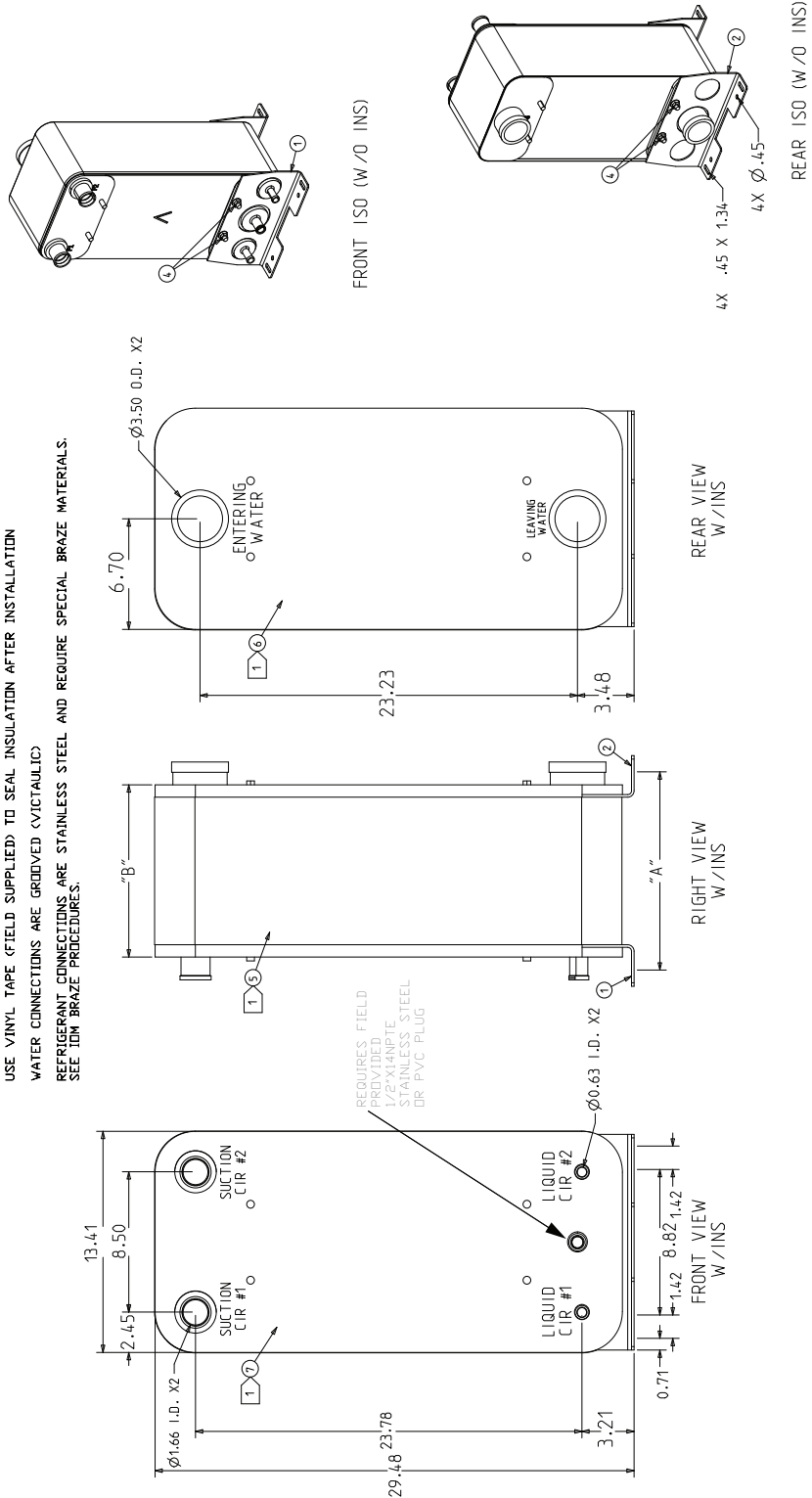


Figure 40. 50 and 60-Ton Evaporator Chiller

Notes:
 THIS HEAT EXCHANGER IS INTENDED FOR INDOOR INSTALLATION ONLY.
 HEAT EXCHANGER MOUNTING LEGS ARE INSTALLED AT JOB SITE WITH SUPPLIED FASTENERS (ITEM 4).
 ATTACH MOUNTING LEGS BEFORE PIPING AND INSULATING.
 INSULATION (ITEMS 5, 6, & 7) SHOULD BE INSTALLED AFTER INSTALLING LEGS & REFRIGERANT
 TUBING, OR MUST BE ADEQUATELY SHIELDED AGAINST HEAT WHEN BRAZING REFRIGERANT LINES
 INSTALL. FACE INSULATION FIRST (ITEMS 6 & 7), THEN WRAPPER INSULATION (ITEM 5), ITEM 5 MAY
 REQUIRE TRIMMING.
 USE VINYL TAPE (FIELD SUPPLIED) TO SEAL INSULATION AFTER INSTALLATION.
 WATER CONNECTIONS ARE GROOVED (VICI-TALUC).
 REFRIGERANT CONNECTIONS ARE STAINLESS STEEL AND REQUIRE SPECIAL BRAZE MATERIALS.
 SEE IOM BRAZE PROCEDURES.

TONNAGE	"A"	"B"
50 TON	10.51	8.93
60 TON	12.01	10.44

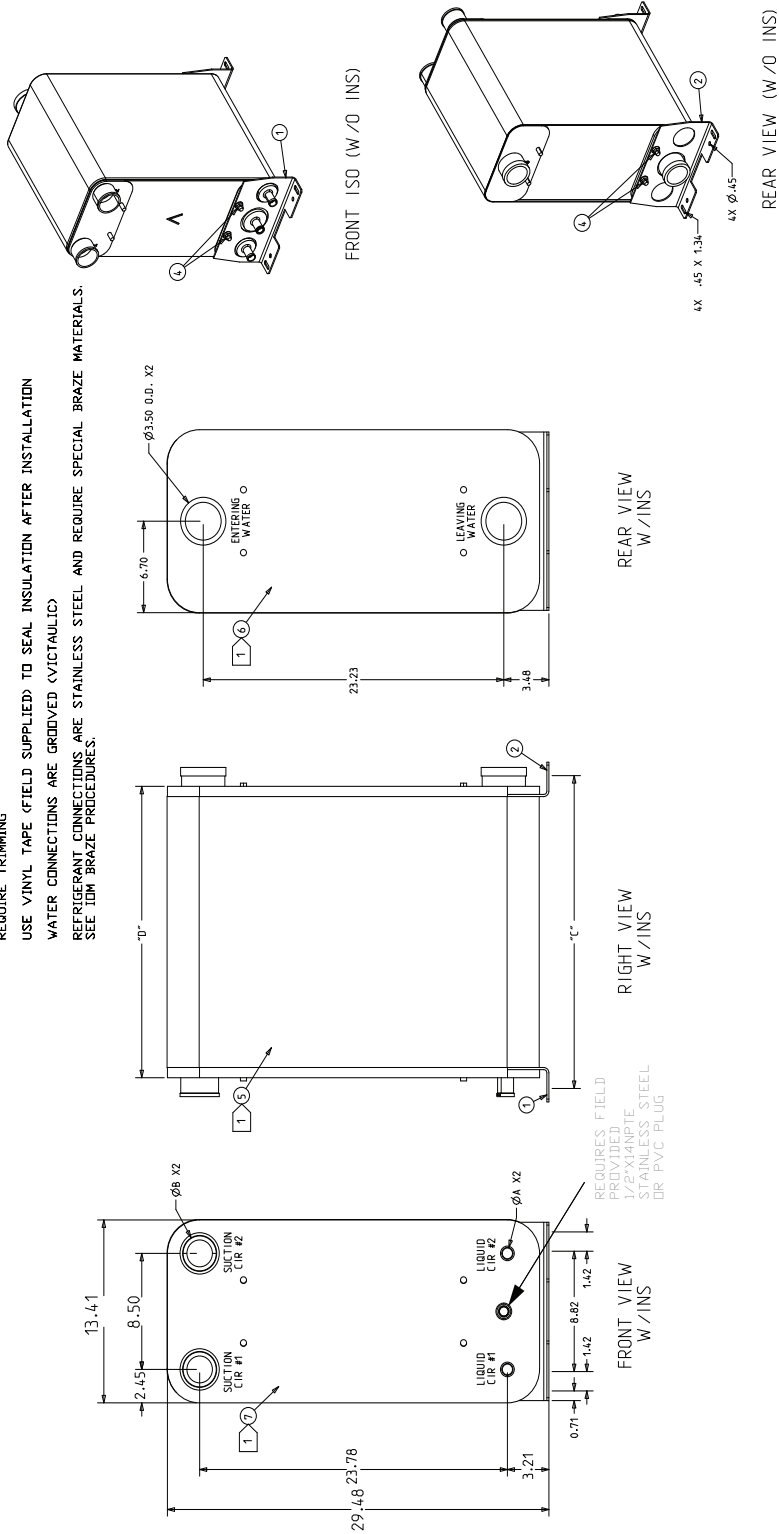


Dimensional Data

Figure 41. 80, 100, and 120-Ton Evaporator Chiller

Notes:
 THIS HEAT EXCHANGER IS INTENDED FOR INDOOR INSTALLATION ONLY.
 HEAT EXCHANGER MOUNTING LEGS ARE INSTALLED AT JOB SITE WITH SUPPLIED FASTENERS (ITEM 4).
 INSULATION (ITEMS 5, 6, & 7) SHOULD BE INSTALLED AFTER INSTALLING LEGS & REFRIGERANT TUBING, OR MUST BE ADEQUATELY SHIELDED AGAINST HEAT WHEN BRAZING REFRIGERANT LINES.
 INSTALL INSULATION SIDE PIECES FIRST (ITEMS 6 & 7), THEN WRAPPER (ITEM 5), ITEM 5 MAY REQUIRE TRIMMING.
 USE VINYL TAPE (FIELD SUPPLIED) TO SEAL INSULATION AFTER INSTALLATION.
 WATER CONNECTIONS ARE GROOVED (VICITAULOC).
 REFRIGERANT CONNECTIONS ARE STAINLESS STEEL AND REQUIRE SPECIAL BRAZE MATERIALS. SEE IOM BRAZE PROCEDURES.

TONNAGE	ØA	ØB	"C"	"D"
80 TON	0.63 I.D.	2.14 I.D.	15.40	13.82
100 TON	0.75 I.D.	2.14 I.D.	21.05	19.47
120 TON	0.88 I.D.	2.63 I.D.	22.93	21.35





Weights

Table 11. 20- to 120- Ton air-cooled condensing units

Tons	Model	Coil Fin	Operating Weight	Weight On Isolator At Mounting Location (Lbs.)								
				Loc. 1	Loc. 2	Loc. 3	Loc. 4	Loc. 5	Loc. 6	Loc. 7	Loc. 8	
20	RAUJC20	AL	1613	491.5	395.8	410.7	315.0					
		CU	1872	639.8	390.1	407.5	434.6					
25	RAUJC25	AL	1663	511.5	422.9	402.1	326.5					
		CU	1921	631.4	414.2	409.7	465.6					
30	RAUJC30	AL	1678	514.9	412.7	419.8	330.6					
		CU	1936	635.1	403.6	427.1	470.2					
40	RAUJC40	AL	2632	445.0	415.6	453.4	424.0	461.8	432.3			
		CU	3120	526.6	477.2	542.7	492.9	558.9	521.7			
50	RAUJC50	AL	2901	611.0	569.0	419.3	384.8	470.3	446.7			
		CU	3325	597.7	551.4	685.5	639.2	438.7	412.7			
60	RAUJC60	AL	2966	593.0	556.7	430.9	399.4	503.1	482.9			
		CU	3462	570.3	628.2	595.3	653.2	620.2	394.9			
80	RAUJC80	AL	5050	831.4	435.7	786.5	410.3	780.3	406.8	731.3	667.7	
		CU	5783	866.9	389.6	931.4	622.6	924.1	616.3	866.6	565.5	
100	RAUJD10	AL	5780	733.8	641.8	907.6	707.6	919.8	418.3	994.5	456.6	
		CU	6625	1011.0	649.2	1008.8	647.7	1008.4	647.5	1006.2	646.0	
120	RAUJD12	AL	6168	928.6	639.0	916.0	627.9	914.0	626.1	901.4	615.0	
		CU	7489	1082.8	808.8	1072.1	801.6	1070.3	800.5	1059.6	793.3	

Notes:

1. Shipping weight is approximately equal to operating weight.
2. AL = Aluminum Coil Fin
3. CU = Copper Coil Fin

Table 12. Evaporator Chiller Weight

Nominal Tons	Operating Weight (Lbs.)	Ship Weight (Lbs.)
20	55	44
25	102	84
30	140	113
40	128	90
50	201	135
60	238	157
80	321	208
100	459	292
120	505	320

Weights

Figure 1. 20- to 30-Ton air-cooled condensing units

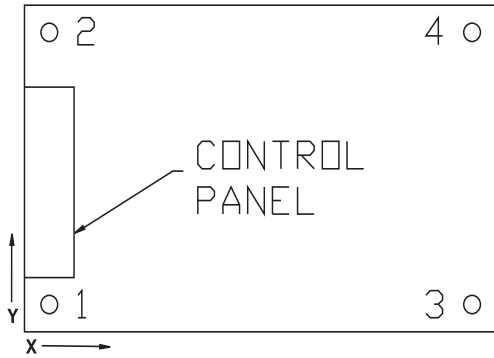


Figure 2. 40- to 60-Ton air-cooled condensing units

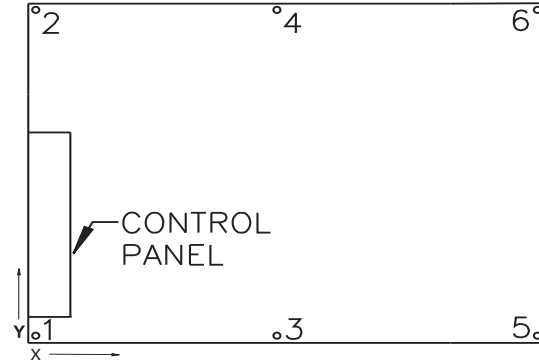


Figure 3. 80- to 120-Ton air-cooled condensing units

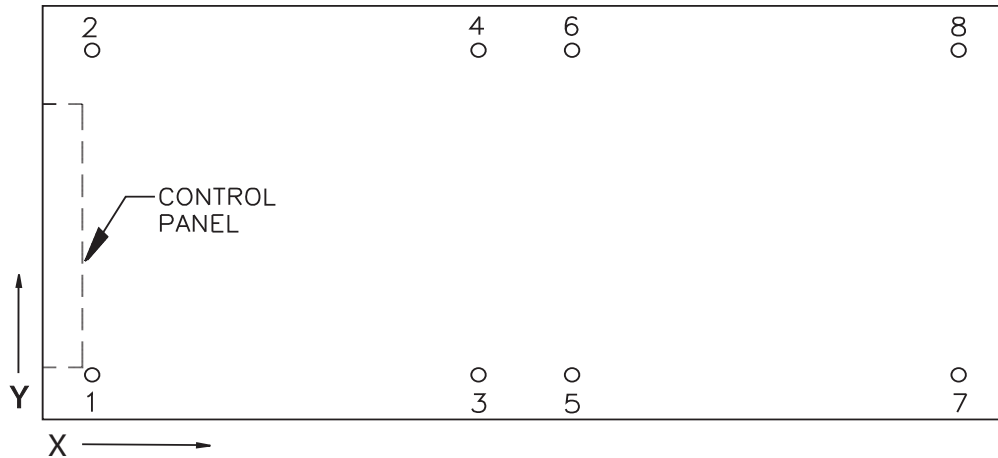


Table 13. Isolator Mounting Locations

Unit Size		Mounting Location							
		1	2	3	4	5	6	7	8
20/25/30	X	8"	8"	6' 8 1/8"	6' 8 1/8"				
	Y	1 1/4"	4' 10 3/4"	1 1/4"	4' 10 3/4"				
40	X	8"	8"	3' 8 1/8"	3' 8 1/8"	6' 8 1/4"	6' 8 1/4"		
	Y	1 1/4"	7' 3 1/8"	1 1/4"	7' 3 1/8"	1 1/4"	7' 3 1/8"		
50/60	X	8"	8"	4' 8 7/8"	4' 8 7/8"	8' 9 3/4"	8' 9 3/4"		
	Y	1 1/4"	7' 3 1/8"	1 1/4"	7' 3 1/8"	1 1/4"	7' 3 1/8"		
80	X	8"	8"	6' 8 1/8"	6' 8 1/8"	9' 1/8"	9' 1/8"	14' 1/4"	• 14' 1/4"
	Y	1 1/4"	7' 3 1/8"	1 1/4"	7' 3 1/8"	1 1/4"	7' 3 1/8"	1 1/4"	4" 7' 3 1/8"
100/120	X	8"	8"	8' 9 5/8"	8' 9 5/8"	10' 1 5/8"	10' 1 5/8"	18' 3 1/4"	18' 3 1/4"
	Y	1 1/4"	7' 3 1/8"	1 1/4"	7' 3 1/8"	1 1/4"	7' 3 1/8"	1 1/4"	7' 3 1/8"

Mechanical Specifications

20 to 120-ton Condensing Units

General

All air-cooled condensing units have scroll compressors and are factory assembled and wired. Each unit is shipped from the factory with a nitrogen holding charge. Units are constructed of 14-gauge welded galvanized steel frame with 14 and 16-gauge galvanized steel panels and access doors. Unit surface is phosphatized and finished with an air-dry paint. This air-dry paint finish is durable enough to withstand a 672-consecutive-hour salt spray application in accordance with standard ASTM B117.

Compressor

Trane 3-D Scroll compressors have a simple mechanical design with only three major moving parts. Scroll type compression provides inherently low vibration. The 3-D Scroll provides a completely enclosed compression chamber which leads to increased efficiency. Exhaustive testing on the 3-D Scroll, including start up with the shell full of liquid, has proven that slugging does not fail involutes. Direct-drive, 3600 rpm, suction gas-cooled hermetic motor. Trane 3-D Scroll compressor includes centrifugal oil pump, oil level sightglass and oil charging valve.

Split systems can have significantly more refrigerant than packaged systems and thus require controls to reliably manage this excess refrigerant. Each compressor shall have crankcase heaters installed, properly sized to minimize the amount of liquid refrigerant present in the oil sump during off cycles. Additionally, the condensing unit shall have controls to initiate a refrigerant pump down cycle at system shut down on each refrigerant circuit. To be operational, the refrigerant pump down cycle requires a field installed isolation solenoid valve on the liquid line near the evaporator

Condenser

Condenser coils have configured aluminum fins mechanically bonded to copper tubing with an integral subcooler. Condensers are factory proof tested at 650 psig. Direct drive vertical discharge fans are statically and dynamically balanced. Three-phase motors have permanently lubricated ball bearings and thermal overload protection. Optional low ambient allows operating down to 0°F with external damper assembly for head pressure control.

Refrigerant Circuits and Capacity Modulation

20 to 30-ton sizes are single circuit and have two steps of capacity. The 40 to 60-ton sizes are two circuits with four capacity steps. Each circuit has two compressors piped in parallel. Discharge and liquid line service valves are standard on each circuit. 80, 100, and 120-ton sizes are two circuits with six capacity steps. Each circuit has three compressors piped in parallel.

Unit Control

Factory-provided 115-volt control circuit includes fusing and control power transformer. The unit is wired with magnetic contactors for compressor and condenser motors, three-leg, solid-state compressor overload protection, and high-low pressure cutouts. Charge isolation, reset relay and anti-recycle compressor timer are provided.

Remote Evaporator Chillers

The remote chiller control option includes an interface panel in the main unit control box and a remote mounted control box that is customer installed. The remote mounted box contains the Honeywell W7100G controller. The chiller controller has an adjustable 0-10°F control band with integrating logic, built in fixed-off timers and field installed discharge water temperature sensors for control and chiller freeze protection. There are two capacity steps on 20, 25 and 30-ton sizes, four capacity steps on 40, 50 and 60 ton sizes and six capacity steps on 80, 100 and 120 ton sizes.

The remote chiller accessory kit includes the evaporator with mounting hardware and insulation, water strainer, minimum water flow limit switch and water side pipe stubs with couplings. The



Mechanical Specifications

chiller is a stainless steel brazed plate heat exchanger designed for up to 150 psig water side working pressure and 430 psig refrigerant working pressure. Chiller mounting is intended for non-freezing locations only. The strainer will prevent system debris larger than 0.039" from entering the evaporator.





www.trane.com

For more information, contact your local Trane office or e-mail us at comfort@trane.com

Literature Order Number	SS-PRC030-EN
Date	April 2010
Supersedes	SS-PRC030-EN (January 2010)

Trane has a policy of continuous product and product data improvement and reserves the right to change design and specifications without notice.