



Product Catalogue

Mercury™

Close control units

Chilled water, direct expansion

Direct Expansion Unit

EDAC / EUAC / EDAV / EUAV / EDWC / EUWC / EDWV / EUWV
1105 - 1106 - 2107 - 2207 - 2109 - 2209 - 2111 - 2211 - 2113 - 2213
2216 - 2218 - 2222 - 4222 - 2225 - 4225 - 4228

Chilled Water Unit

EDCC / EUCC / EDCV / EUCV
0070 - 0100 - 0120 - 0170 - 0200 - 0250 - 0270 - 0340 - 0400



Close control units

Unit identification system	page. 03	Technical data - Chilled water units	page. 19
Air flow configurations	page. 04	Technical data - Air-cooled	page. 23
Cooling system	page. 05	Technical data - Water-cooled	page. 27
Available sizes	page. 05	Dimensions of the air delivery section	page. 29
General description	page. 06	Connections	page. 31
Main features	page. 07	Air-cooled units: suggested refrigeration piping	page. 34
Optional accessories	page. 11	Discharge line	page. 35
Uniguard MP40	page. 12	Liquid line	page. 39
Electronic expansion valve and integrated dehumidification in the microprocessor control	page. 13	Electrical data R410A	page. 41
Electronically commutated fans (EC)	page. 15	Electrical data CW	page. 46
Tandem compressors	page. 16	Sound pressure levels	page. 50
R410A Environmentally friendly refrigerant	page. 17	Dimensions and weights	page. 58
Supervisory	page. 18		



TRANE, certified according to the standard ISO 9001, assures the constant verification and high standard of quality of its own products and services supplied. In addition to having always given particular attention to the subject of environmental sustainability, TRANE has obtained the certification ISO 14001 guaranteeing products and services meet the challenge of the growing problems and new expectations of the market. MERCURY™ Direct Expansion units are in conformity with the following directives: **2006/42/EC - 2004/108/EC - 2006/95/EC - 97/23/EC - 842/2006/EC F-GAS regulation**. MERCURY™ chilled water units are in conformity with the following directives: **2006/42/EC - 2004/108/EC - 2006/95/EC**.

E	D	A	V	2	1	07	A
E	U	C	B	0	0	25	A

FAMILY	AIR PATTERN	COOLING SYSTEM	VENTILATION TYPE	NUMBER OF COMPRESSORS	NUMBER OF REFRIGERANT CIRCUITS	UNIT SIZE	SUPPLY VOLTAGE
	U = upflow; front, bottom or back air return	C = chilled water units	V = centrifugal fans with backward-curved blades with electronic commutation			Indicative cooling capacity	A = Alimentazione 400 V / 3 Ph (+N) / 50 Hz
	D = downflow; top air return	A= direct-expansion, air cooled W = direct-expansion, water cooled	B = centrifugal fans with backward-curved blades				

CONFIGURATION
C = Cooling only
D = Cooling + humidification
U = Cooling + dehumidification
C + Electric heater
C + Dehumidification + electric heater
D + Electric heater

EN AIR FLOW CONFIGURATIONS

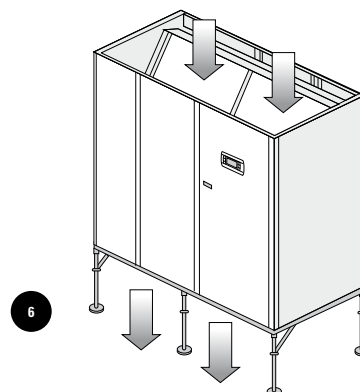
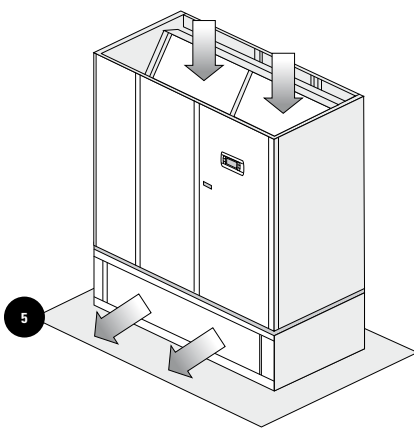
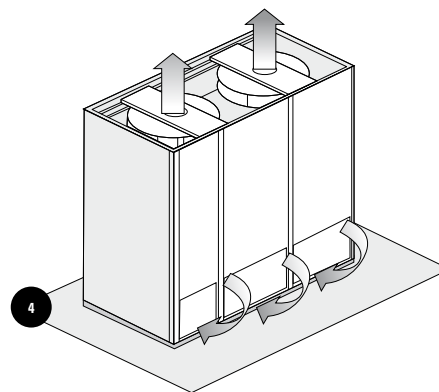
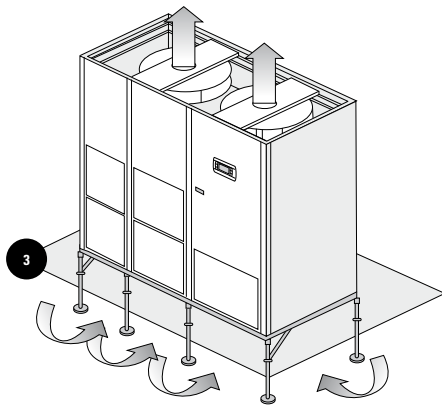
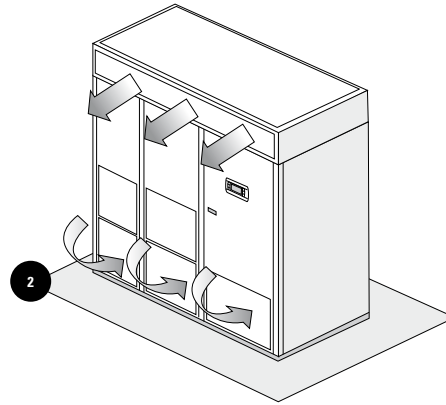
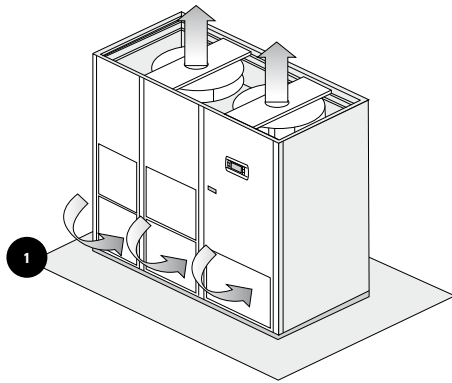

Available version:

AIR PATTERN

- 1) Upflow unit with front air suction
- 2) Upflow unit with front discharge plenum
- 3) Upflow unit with bottom air suction
- 4) Upflow unit with back air suction
- 5) Downflow unit with front air discharge base module
- 6) Downflow unit with top air suction

Versions:

- C) Chilled water.
- A) Direct expansion, air-cooled.
- W) Direct expansion, water-cooled.

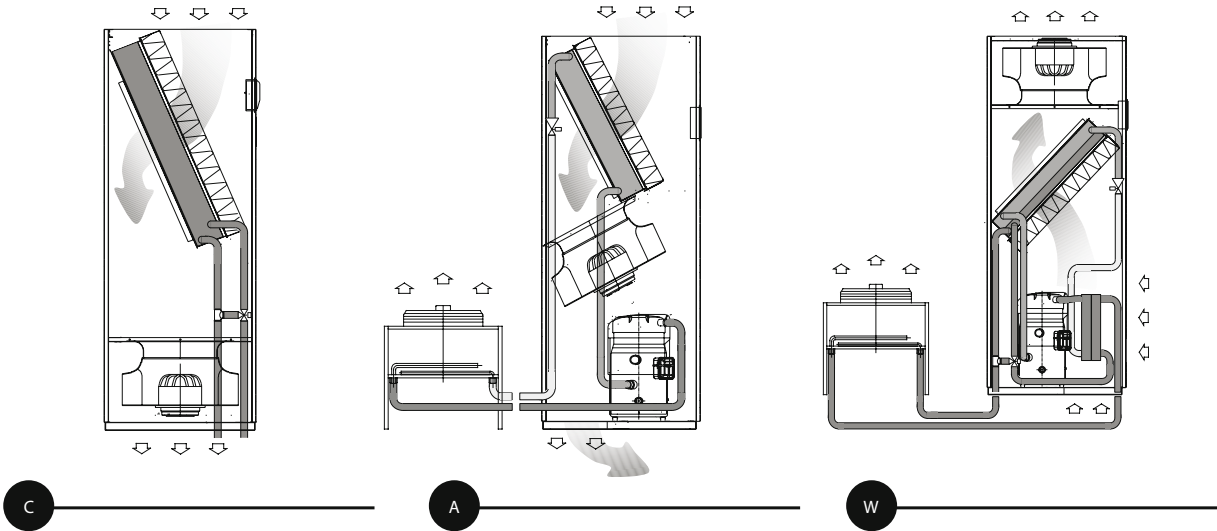

C. SYSTEM	CW		DX							
	V	B	V	B	V	B	V	B	V	B
N. Comp.	0		-		-		-		-	
N. Cir.	0		1		2		2		4	
Vent.										
FRAME 3 (1010X750X1960 mm)	0070		1105 (A) 1106 (A-W)		-		-		-	
FRAME 4 (1310x865x1960 mm)	0100 0120		-		2107 (A) 2109 (AW)		2207 (A) 2209 (A)		-	
FRAME 5 (1720x865x1960 mm)	0170		-		2111 (A) 2113 (AW)		2211 (A) 2213 (A)		-	
FRAME 6 (2170x865x1960 mm)	0200 0250 0270		-		-		- 2216 (AW) 2218 (AW)		-	
Frame 7 (2580x865x1960 mm)	0340 0400		-		-		- 2222 (A) 2225 (A)		4222 (AW) 4225 (AW) 4228 (AW)	

- C.SYSTEM: Cooling System
- N.COMP.: Number of compressors
- N.CIRC.: Number of refrigerant circuits
- VENT: Ventilation Type
- V: Centrifugal fans with backward curved blades with electronic commutation
- R: Centrifugal fans with backward curved blades
- FRAME: Dimensions (height, width, depth)
- A: Air cooled
- W: Water Cooled

1. General description

MERCURY™ is the new range of precision air conditioners developed by TRANE™, conceived and designed specifically to meet the air conditioning needs of call centers and Internet providers, data-processing centers and, more generally, any technological environment characterized by high levels of heat value to dissipate. To guarantee the proper operation of the equipment in such installations, it becomes essential to keep the temperature and humidity conditions constant throughout the year; that is why we speak of controlling the ambient conditions, not just cooling. The air-conditioning systems intended for the purposes of "comfort" are designed specifically to guarantee the well-being of the people in the room and are generally incapable of ensuring that the ambient conditions required by technologically sophisticated equipment can be kept constant, especially in the presence of much higher specific heat loads. In precision air-conditioning applications, on the other hand, there are four main objectives to pursue, which prompt important design decisions that distinguish precision air-conditioners from those intended to ensure personal comfort:

- air temperature control ($\pm 1.0^{\circ}\text{C}$)⁽¹⁾
- air humidity control ($\pm 7/8\%$)
- high airflow rate
- year-round operation (24 hours a day, 365 days a year)
- energy efficiency

In the air-conditioning of large technical rooms used for telephone and Internet applications, the density of the heat load (per unit of surface area) is very high, even as much as 6-10 times the density of the heat load in comparable areas used as commercial offices, for instance. Standard air-conditioning equipment designed for ensuring comfort are unable to cope with such densities and types of heat load, especially concerning the total absence of any latent load characteristic of technological applications.

(1): the capacity to maintain relative humidity and air temperatures within tolerance thresholds, depends on the characteristics of the unit and the installation environment; the values indicated are possible only during optimum running conditions.

Air temperature control

The air conditioners in the new MERCURY™ range are able to control the air temperature in the conditioned room with utmost precision, adapting their cooling or heating capacity to the heat load in the room by means of sophisticated microprocessor control PID algorithms designed and developed by TRANE™. They are also able to react promptly to any major changes in the heat load, restricting to a minimum any oscillation in the ambient temperature with respect to the set point which depending on the version may be based on the air return temperature or the discharge temperature.

Air humidity control

The sophisticated equipment contained in the rooms requiring precision air-conditioning must be adequately protected both from any condensation inside the room and from any static electricity charges. To achieve this objective, it is essential to control the humidity level in the room extremely accurately. In fact, an excessively high humidity level can lead to condensation forming inside the electronic equipment, whereas if the humidity level is too low there is a danger of a build-up of static electricity [R.U. <30%]. Both versions are potentially harmful to the electronic equipment and must be prevented and avoided.

High airflow rate

The conditioners in the new MERCURY™ range are the outcome of an accurate fluid dynamics study which has enabled the airflow to be optimized, ensuring high specific air flow rates in order to guarantee a high SHR [Sensible Cooling/Total Cooling ratio].

Rooms occupied by equipment used for telephone or internet transmission, as well as large data processing centres require high airflows to cope with the ambient heat load without having to resort to excessively low air delivery temperatures, thus guaranteeing uniform conditioning for all parts of the room. The high density of the heat loads which are characteristic of such applications, together with the lower thermal inertia of the system, requires the number of cycles per hour to be about 10 times more than that for an air-conditioning application for the purposes of comfort cooling in order to avoid troublesome fluctuations in temperature.



Year-round operation (24 hours a day 365 days a year)

The air conditioners in the new MERCURY™ range are designed to operate all year round without interruption and all of the technical and procedural decisions have been made with a view to achieving an extremely high degree of reliability for the equipment. The sophisticated research behind their design has combined an accurate selection of the components involved with an innovative production process guaranteeing absolute reliability and increased energy efficiency, fundamental aspects when constant control of the ambient conditions is required. These results are achieved not only through appropriate selection of the components (resulting from the many years of experience acquired in the field of air-conditioning for technological environments), but also through accurate design of the software used to design the equipment and the rigorous testing carried out in the TRANE™ research and development laboratory. This software is based on the event prediction principle, which enables action to be taken in advance on the strength of analysis on the trends of the room temperature, guaranteeing precision and optimising energy consumption.



Energy efficiency

The air conditioners in the new MERCURY™ range have been designed to operate all year round, it is necessary, therefore, for the units to be optimized in such a way as to guarantee minimum electrical absorption in all operating conditions resulting in reduced running costs. In order to guarantee maximum energy efficiency the units have been designed to optimise the heat exchange surface and the fluid dynamics in order to reduce the electrical absorption of the fans and the compressors. All of the versions are available with two types of fans, traditional and electronically commutated in order to minimise electrical absorption. All of the direct expansion units can be selected with tandem compressors to increase energy efficiency at partial loads while the electronic thermostat is installed in all of the units.

The MERCURY™ range offers a complete range:

- Direct expansion models (**DX**), air or water cooled;
- Chilled water models (**CW**) (which can be controlled using the set point on both the air return and the discharge).

2. Main features

High sensible cooling capacity and high SHR (Ratio between sensible cooling capacity and total cooling capacity). This characteristic is particularly important in technological applications, where the heat load is completely sensible and therefore distinguishes this type of environment from similar equipment designed for comfort applications. Sturdy industrial design and semi-automatic assembly using top-quality reliable components. The new design of the MERCURY™ range is the evolution of a configuration specifically designed by TRANE™ and fully tested in the field.

Low running costs, achieved by means of sophisticated design together with an accurate selection of the components.

The entire MERCURY™ range is “Environment Friendly” because it uses materials which can be recycled, particularly the plastics and thermal insulation.

Ease of installation due to the fact that all of the components necessary for operation are contained within the unit and for the operation of which only the following are necessary:

- electrical wiring to the mains switchboard;
- hydraulic connections for the condenser drain, the humidifier (version D) and hot water reheat (optional);
- chilled water connections (in CW units);
- connections to the remote condenser or to the dry-cooler
- refrigerant charge (in air cooled DX).

Full frontal accessibility for all versions. This feature enables the main components to be accessed from the front for installation purposes and routine servicing. Thanks to this feature, the machines can be installed side by side, in between cabinets (racks) therefore reducing the dimensions of the conditioning system.

The structure of the unit is characterized by a metal framework and internal parts made from hot zinc plated sheet steel. These profiles are connected together by structural rivets designed to ensure sturdy assembly and which are capable of withstanding severe transport and handling conditions. The units are also equipped with internal panels for shutting off the compartments affected by the air flow produced, these are made from hot zinc plated sheet steel and ensure:

- reduction in the noise transmitted through the panelling;
- air tightness even without external panels so that the units can also operate with the doors open during servicing;
- the possibility of inspecting the internal elements without interfering with the operation of the unit and, more importantly, with the unit in operation.

The external panels are coated with RAL 9002 epoxy-polyester paint which guarantees long-term durability of the original features. The front panels are attached to the framework by means of rapid coupling fasteners. The standard panels are internally lined with heat and sound proofing insulating material made of melamine covered by a protective film. Melamine is an exceptionally high-quality product, coupled with high fire-resistance (class B1 according to DIN 4102, BS 476 part 7, V0 according to UL94, ASTM E84, class M1 according to NFP92-501) and excellent sound-insulation properties.

Two possible options are available for the **fan section** of all of the models:

Single-inlet centrifugal fans with backward curved fan blades (“B” version)



This type of fan has an aluminium impeller with a low moment of inertia. The directly coupled electric motor is three-phase (or monophase in the smaller models) with an external motor with IP10 Class F protection grade with the possibility of regulating the speed by means of an autotransformer. The fan impeller is statically and dynamically balanced with lifelong-lubricated sealed bearings. The fan is mounted on a support which reduces the transmission of vibrations to the body of the appliance. The way in which it is mounted allows the fan to be replaced without having to take the motor of the impeller apart. The fan speed can be selected to adapt the air flow to the head pressure required by the aeraulic system. Increasing the turning speed to obtain greater head pressures naturally means an increase in the sound pressure level produced by the unit which must be taken into account when assessing the acoustics of the installation. The control system has been specifically designed to ease servicing and maintenance.

Single-inlet centrifugal fans with EC (Electronically commutated) backward curved fan blades (“V” version)



This type of fan has an aluminium impeller with a low moment of inertia and an innovative vane profile. The directly coupled EC motor is three phase with an external rotor, with IP54 protection grade, with the possibility of continuous regulation of the speed by means of a 10V signal sent by and integrated with the control. The fan impeller is statically and dynamically balanced with lifelong-lubricated bearings. The fan is mounted on a support which reduces the transmission of vibrations to the body of the appliance. The fan speed can be selected to adapt the air flow to the head pressure required by the aeraulic system. The EC fans, thanks to their innovative technology, guarantee lower electrical absorption compared to all other types of fans available on the market and a noise power level which is particularly low. Increasing the turning speed to obtain greater head pressures naturally means an increase in the sound pressure level produced by the unit which must be taken into account when assessing the acoustics of the installation. The control system has been specifically designed to ease servicing and maintenance.

EN 2. MAIN FEATURES

Using this highly-reactive fan with backward curved blades, rather than a traditional fan with forward curved blades, has the following advantages:

- higher static pressure levels;
- increased ratio between available static and dynamic pressure;
- the assembly of the whole fan section has been designed to facilitate servicing.

The use of a directly coupled motor substantially increases the yield from the heat dispersed into the air and the absorbed power than that which can be obtained with fan systems featuring a drive belt, it also dramatically reduces the need for maintenance intervention and guarantees total reliability.

The cooling coil has been designed with a large front surface in order to have an elevated SHR and a low air crossing speed in order to eliminate droplets of condensation, reduce pressure drops in the air and ensure a more efficient heat exchange during both the cooling and dehumidification processes. The coil is made from copper tubes mechanically expanded on aluminium fins, complete with a **hydrophilic treatment** to reduce the surface tension between the water and the metal surface, promoting film condensation and avoiding the risk of condensation droplets forming outside the condensate drain tray. In chilled water units the coil is situated upstream from the fans in order to ensure optimum air distribution and has a stainless steel condensate drain tray with a flexible drainage tube and an integrated siphon. In DX models the cooling coil is built with two circuits which are linked together to maximise the exploitation of the exchange surface of the coil regardless of which refrigerant circuit is actually operating at the time. In DX downflow units the coil is situated downstream from the fans and allows the layout of the internal components to be optimised.

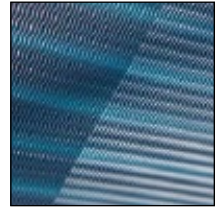

Box type air filters made from self-extinguishing, synthetic fibre cellular material. The frame containing the filter material is made of metal. The pleated arrangement of the filters extends the surface area ensuring a high filtering efficiency and low pressure drops. The filtering rate is **EU4** (standard) or, on request, **EU5** (according to EUROVENT 4/5); in which case the filters are mounted inside the equipment, upstream from the coil. It is extremely easy to access and remove the filters in all unit configurations. Filtering rates of up to **EU7** are available on request; in this case, the filters are mounted on the plenum or on a base frame outside the unit. The unit can be supplied with a high capacity (optional) filter for air renewal which is connected to the outside by means of a flexible conduit; in the DX version, a small booster fan is provided.



Low airflow and clogged filter alarm sensors (standard on all models) consisting of two pressure switches for controlling the operating conditions of the fans and the build up of dirt on the air filters inside the unit.

Hydraulic circuit (CW models)

The piping for the hydraulic circuit is coated entirely with closed-cell insulating material to class 1 according to DM 26.06.84, class 1 according to BS476 part 7, ASTM E 162-87, reduced fume opacity measured according to ASTM 662-79. The unit can be fitted with a two-way or three-way valve with a remote controlled servomotor. The maximum pressure is 6 bar (PN6). Units with higher maximum pressures can be supplied on request.

Hermetic scroll compressors (air and water cooled DX models), featuring an elevated C.O.P (Coefficient of Performance) and therefore high energy efficiency. Scroll compressors have the following features:

- Low noise emissions;
- Low vibration level, improved also due to installation on anti-vibration supports;
- Increased MTBF (Mean Time Between Failures);
- Reduced rush current;
- Integrated heat protection;
- Mounted inside a dedicated space which is separate from the air flow to ensure easy monitoring during operation, without having to switch the equipment off.

Refrigerant circuit (air and water cooled DX models)

The MERCURY™ direct expansion range offers the possibility of choosing different configurations for the refrigerant circuit on units with the same capacity:

- A single circuit with one compressor;
- A single circuit with two tandem compressors on one circuit for increased efficiency and regulation capacity at partial loads;
- A dual-circuit with one compressor.

Each circuit features:

- Liquid receiver with rotalock on-off valve and safety valve;
- Dehydrating filter and liquid sight glass. The first enables the refrigerant circuit to be kept free of humidity (therefore increasing the life of the components), while the second allows a rapid check to see if the system is correctly charged with refrigerant and whether it contains any humidity;
- Thermostatic electronic expansion valve controlled by the microprocessor with special software created and tested by TRANE™. This enables the refrigerant flow through the evaporator to be adjusted, controlling the real evaporator superheating in relation to changes in the ambient conditions, increasing the precision of the cooling and the energy efficiency of the cooling cycle;
- High pressure switches with manual resetting;
- External welded connections (units with R410 refrigerant).

Refrigerant fluid: R401A refrigerant is standard on all of the direct expansion models.

The entire MERCURY™ series is "Ozone Friendly" in terms of both the refrigerant fluids it uses and the foaming agents used for the insulating material. In the water cooled units the refrigerant circuit is pre-charged with refrigerant, while in the units with remote condenser the circuit is filled with dry nitrogen: the unit must be emptied and charged with refrigerant by the installer; guidelines are available for calculating the piping and estimating the amount of refrigerant required.

Internal water-cooled condenser (water cooled DX models); braze welded and made of AISI 304 stainless steel.

Remote air-cooled condenser (water cooled DX models)

These units are characterised by a single or dual circuit with copper tubes and aluminium fins, complete with low speed axial fans to reduce the sound pressure level. Air-cooled condensers for use with R410A are called **CAP**, the framework is made of galvanised steel coated in epoxy powders with excellent weather resistant properties and are equipped with standard welded attachments. Special surface treatments on the finned coil are available on request and increase the resistance to more aggressive weather conditions. The remote condenser is complete with an electric power and control board which is fully wired and tested in the factory. The fan management is of the standard modulating type with phase cutting regulation, for correct operation during the winter months down to temperatures of -20°C and with wind speeds perpendicular to the coil below 2.5 m/s. For lower temperatures, down to -40°C, high-resilience steel liquid receiver and flooding valve, both within the overall dimensions of the equipment are available on request; in this case the phase cutting regulation is inside the MERCURY™ unit.

Remote Dry-cooler with water/glycol (water cooled DX models) characterized by an exchanger with copper tubes and aluminium fins with low speed axial fans in order to reduce the sound pressure level. The framework is made of embossed aluminium, with excellent weather-resistant elements. Special surface treatments on the finned coil are available on request and increase the resistance to more aggressive weather conditions. The dry cooler is complete with an electric power and control board which is fully wired and tested in the factory.

Electric Heating with aluminium finned heating elements complete with safety thermostat with manual resetting to cut off the power supply and activate the alarm in the event of superheating. Two heating power levels are available for each model: standard and boosted. This is divided into three stages to allow for reduced electrical consumption. These three stages result in excellent temperature regulation according to the needs of the room which is to be conditioned. The finned elements are characterized by high efficiency in order to maintain a lower power density on the surfaces, therefore limiting superheating of the elements and increasing their durability. Thanks to the low surface temperature of the heating elements, the air ionization effects are also limited. This heating system has a dual purpose:

- heating the air to bring it up to the set-point;
- reheating during the dehumidification phase, in order to bring the temperature of the air to the set-point. The installed heating capacity is therefore capable of maintaining the dry bulb temperature in the room during operation in dehumidifier mode.

Heating with a hot-water coil

This system is proposed as an alternative, or in combination with the electric heating system. It is characterised by a hot water coil made with copper tubes and aluminium fins in a single array, tested 45 bar. The reheat coil is made with a valve for venting air from the hydraulic circuit positioned at the highest point and accessible from the front, and a three-way modulating regulation valve with a servomotor controlled directly by the unit's microprocessor control. When it is used in combination with electric heating, this system takes priority over the latter. It serves a dual purpose:

- heating the air to bring it up to the set-point;
- reheating during the dehumidification phase, to make the temperature and humidity separate from each other.

The capacity of the heating installed is able to maintain the dry bulb temperature in the room during dehumidification mode.

Hot gas reheating

In the original TRANE version, this reheating system is proposed as an alternative to hot water heating and is only available in the DX. It exploits part of the heat released to the condenser to reheat the air destined for the room which is being conditioned, thereby achieving a worthwhile energy saving. It features a coil with copper tubing and aluminium fins and is situated downstream of the evaporating coil. This system is activated during the dehumidification phase when the air temperature falls below the set point, this system enables the temperature and relative humidity to be regulated separately. Accurate temperature regulation is naturally the responsibility of the unit's microprocessor control, which manages an ON-OFF valve feeding the reheat coil. When it is used in combination with electric heating, this system takes priority over the latter.

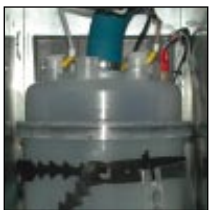

Immersed-electrode humidifier for modulating sterile steam production with automatic regulation of the concentration of salts in the boiler to allow for the use of untreated water. It is therefore possible to use water with varying degrees of hardness and without the need for any chemical treatment or demineralising. The humidifier has a steam cylinder, a steam distributor (installed immediately downstream from the exchanger), water intake and delivery valves and a maximum level sensor. Proportional control of the humidifier operation (achieved by controlling the electric current allowed to pass through the cylinder's electrodes and the management of salt concentration inside the cylinder) guarantee perfect efficiency of the system, energy saving and greater durability of the components.

EN 2. MAIN FEATURES

The steam cylinder is installed outside the air flow to avoid any heat losses. The unit's microprocessor control indicates when the steam cylinder has to be changed because it is empty; the steam cylinder can be, on request, the type which is able to be inspected so that the electrodes can be routinely cleaned to remove any lime scale. The microprocessor control can also manage a dehumidifier installed outside the equipment, not supplied by TRANE, on the air distribution channel. The table below indicates the water supply application values for the humidifiers:

			LIMITS	
			Min	Max
hydrogen-ion activity	pH		7	8,5
specific conductivity at 20°C	$\sigma_R, 20^\circ\text{C}$	$\mu\text{S/cm}$	350	1250
total solid dissolved	TDS	mg/l	(¹)	(¹)
fixed residue at 180°C	R ₁₈₀	mg/l	(¹)	(¹)
total hardness	TH	mg/l CaCO ₃	100 (²)	400
temporary hardness		mg/l CaCO ₃	60 (³)	300
iron + Manganese		mg/l Fe + Mn	0	0,2
chlorides		p pm Cl	0	30
silica		mg/l SiO ₂	0	20
residual chlorine		mg/l Cl ⁻	0	0,2
calcium sulphate		mg/l CaSO ₄	0	100
metallic impurities		mg/l	0	0
solvents, diluents, soaps, lubricants		mg/l	0	0

(¹) Values depend on the specific conductivity; in general: TDS = 0,93* σ 20; R180 = 0,65* σ 20

(²) Not less than 200% of the chloride content in mg/l of Cl⁻

(³) Not less than 300% of the chloride content in mg/l of Cl⁻

Electrical panel situated in a compartment separated from the air flow and made in compliance with the 2006/95/CE directive and related standards. The main features are as follows:

- a three-phase power supply 400V/3ph+N/50Hz for all of the units except units where the neutral is only present when there is an optional condensate drain pump and/or a fan booster for air renewal;
- low voltage secondary circuit 24 Vac with isolation transformer;
- plastic isolating screen for protection from live components;
- general isolator with mechanical interlock;
- thermomagnetic circuit-breakers for protection;
- terminal board for no-voltage signal and control contacts.

All of the units undergo a safety test cycle to check the continuity of the protection circuit and the insulation resistance and a voltage test (dielectric strength). Power factor improvement condensers are available for all models except those with chilled water and EC fans.

3. Optional accessories

Optional accessories supplied assembled on the unit

Discharge temperature limit sensor (on request only for CW units), which regulate the opening of the three-way valve to keep the air temperature at the condenser outlets above a threshold value.

Discharge temperature control (only available on CW units) which, by means of an integral proportional algorithm regulates the opening of the three-way valve to guarantee the value of the air temperature at the condenser outlets is maintained. **Two way pressure regulating valve** for regulating the condensing water flow rate (only on water cooled DX) **Condensing pressure regulation system (HP8)** equipped with three-way flooding valve on the condenser (only on water cooled DX).

Double Power Supply with Automatic Changeover (available only on CW models) In order to grant a redundancy on power supply Chilled Water units can be equipped with double power supply with automatic changeover; units will be powered by two power lines, line A (main) and line B (emergency), if unit A is not available for a main line loss the unit automatically switches electromechanically to line B; when power on line A comes back the unit switches automatically on Line A thanks to the possibility of selecting the priority line with a manual selector.

Optional accessories supplied with the on site assembling kit

The microprocessor control system can be supplied with the following optional cards:

- **Serial adaptor RS485 card** for transmitting data to a centralized supervision system with STD or MODBUS protocol;
- **Clock card** for managing the time bands and the operation hours counter;
- **TCP/ IP interface board** for connecting the units to the network managed by a BMS operating with a SMNP or TCP/IP protocol;
- **LON serial card** for connecting the units to a network with a BMS operating with LON protocol.

External sensors for high temperature alarms or high ambient temperature and humidity.

Condensate drain pump (C and electrical heaters versions).

Humidifier and condensate drain pump (D version), suitable for eliminating the hot water produced by the humidifier.

Fire and /or smoke detector

Water leak detector comprising of a control module installed inside the electrical panel and an external sensor. Connecting numerous additional leak detector sensors or using a sensor strip probe can be carried out in order to check several points.

Upflow units

The following accessories are available for upflow units:

- **Base frame** (height 200 mm) with removable front panel featuring pre-punched holes on the side to allow for connection to a raised floor. The internal panels are lined with standard sound-proofing material or with panels to class A1⁽¹⁾.
- **Base frame** (height 500 mm) WITH MOTORIZED DAMPER insulated with standard sound-proofing material or with panels to class A1⁽¹⁾. This is usually used in combination with intake from the bottom.
- **Base frame** (height 500 mm) WITH HIGH EFFICIENCY FILTERS insulated with standard sound-proofing material or with panels to class A1⁽¹⁾, with high efficiency filters ranging from class EU6 to class EU7. The filters are accessible from the front.
- **Discharge plenum** (height 500 mm) for connecting the top of the unit to a false ceiling or to the air delivery channel. The internal panels are lined with standard sound-proofing material or with panels to class A1⁽¹⁾. The plenum is also available in a version with melamine resin filter plates (class 1 according to D.M. 26.06.84, class B1 according to DIN 4102, class 94 V-0 and 94 HF-1 according to UL94, class M1 according to NF P92-501). There is also a version available on request for installing high-efficiency air filters ranging from class EU6 to class EU7. The filters are accessible from the front.
- **Discharge plenum** (height 500 mm) WITH FRONT GRILLE and a double array of fins, coated with standard sound-proofing material or with panels to class A1⁽¹⁾.
- **Gravity overpressure damper** to prevent a reverse flow of air when the unit is not operating in installations where there are several units in the same room. The damper is mounted in a plenum positioned on the upper part of the unit with an additional height of 150 mm and masking coated.
- **Motorized damper** to prevent a reverse flow of air when the unit is not operating, in installations where there are several units in the same room. The damper is controlled by the remote control of the fans. The damper is mounted in a plenum positioned on the upper part of the unit with an additional height of 150 mm and masking coated.
- **Main frame** for assembly on a raised floor. The main frame is adjustable in height (± 25 mm) from 200 mm to 600 mm and is provided complete with anti-vibration supports.

Downflow units

The following accessories are available for downflow units:

- **Air intake plenum (height 500 mm)** installed between the top of the unit and a false ceiling or to the air delivery channel. The internal panels are lined with standard sound-proofing material or with panels to class A1⁽¹⁾. The plenum is also available in a version with melamine resin filter plates (class 1 according to D.M. 26.06.84, class B1 according to DIN 4102, class 94 V-0 and 94 HF-1 according to UL94, class M1 according to NF P92-501). There is also a version available on request for installing high-efficiency air filters ranging from class EU6 to class EU7. The filters are accessible from the front.
- **Air intake plenum** (height 500 mm) with motorized damper insulated with standard sound-proofing material or with panels to class A1⁽¹⁾, installed on the discharge of downflow units. The damper is controlled by the remote control of the fans and prevents a reverse flow of air when the unit is not operating, in installations where there are several units in the same room.
- **Base frame** (height 500 mm) with front discharge grille insulated with standard sound-proofing material or with panels to class A1⁽¹⁾, installed on the discharge of downflow units. The frame is fitted with an internal deflector to guide the air flow to the outlet of the unit.
- **Main frame** for assembly on a raised floor. The main frame is adjustable in height (± 25 mm) from 200 mm to 600 mm and is provided complete with anti-vibration supports.
- **Main frame** for assembly on a raised floor is fitted with an internal deflector to guide the air flow to the outlet of the unit.

(1) The sound-proofing material indicated as "standard" is class 1 according to D.M. 26.06.84 and class B1 according to DIN 4102; the panels indicated as class "A1" are class 0 according to D.M. 26.06.84 and class A1 according to DIN 4102.

4. Microprocessor MP40



The microprocessor control of the MERCURY™ units automatically manages unit operation and has the following principal components:

- user interface;
- integrated microprocessor control board to which the probes are connected as well as all of the analogical and digital inputs necessary for control of the unit.

The Uniguard MP40 user terminal is equipped with a 64x120 pixel backlit LCD display and 6 backlit keys to move between and change parameters. The user terminal can be placed onboard the unit or, on request, with remote control. By means of the user terminal it is possible to set the operating parameters, monitor the trend of the main working parameters and read any alarm messages. All of the control algorithms can be found in the microprocessor control board (in a flash eeprom) and all of the operating parameters are memorized and can be viewed using the user terminal. The LAN card for connection to a Local Area Network is integrated in all units as a standard feature and enables up to 10 units to be controlled in the same room. Compatibility with Modbus protocol is an integrated feature on all of the units (with RS485 serial card).

The control system enables the following functions:

- temperature and humidity control based on a set point which can be set by the user interface;
- possibility of setting a double temperature set-point (both in cooling and heating) and humidity set point (both in dehumidification and humidification) which can be set remotely;
- complete alarm detection system;
- alarm event history storage;
- alarm signal contacts which can be set on the user interface;
- automatic restart when power returns after a cut out;
- remote switching on / off of the unit;
- password on 2 programming levels (settings and service);
- possibility of communicating with a supervision system by means of an RS485 serial card (optional);
- clock/date management (optional clock card);
- operating hour counter and the number of inrush currents of the main components;
- graphic display with icons displaying the state of the unit components and showing all of the values read by the probes connected to the control board;
- time bands for differential weekly switching on/off of the unit (with optional clock card): weekday - saturday - holiday;
- management of the local network with the possibility of setting the rotation of one or two units in stand-by;
- operation of these units in set back mode, and regulation based on the average temperature;
- "override" function with which the operation of the main components can be manually controlled without excluding the possibility of remote control;
- possibility of deactivating some of the digital inputs (e-g: Humidifier/Heaters) for emergency situations/auxiliary generators;
- alarm sequence history with up to 100 alarm events (with date and time if there is a clock card);
- flexible management of the **digital alarm outputs**, that is, the possibility of independently addressing all of the outputs available (in almost all cases, 2), and to determine if the contact state must usually be open or closed;
- flexible management of the alarms which cause, when there is LAN connection, the intervention of the stand-by units;
- the possibility for some alarms, of setting the **automatic reset** of the alarms;
- the possibility of controlling and managing the operation and parameters of the electronic thermostatic valve; in particular the operation of the valve can be checked and can be modified in order to maximise the general operation of the circuit or to correct any eventual malfunctions, the evaporating pressure/temperature can be monitored and therefore the unit operation can be checked;
- the possibility of selecting **forced timed flushing of the humidifier**.

5. Electronic expansion valve and integrated dehumidification in the microprocessor control

The MERCURY™ units make use of the advantages created by the intelligent management of the Electronic Expansion Valve:

- increased energy efficiency;
- management and monitoring of the refrigerant circuit parameters;
- intelligent dehumidification (at a constant airflow).

The **Electronic Expansion Valve** manages and optimises the onboard microprocessor allowing the COP to increase compared to a standard solution with TEV when the external temperature allows temperatures with a dew point lower than 38°C to be condensed by fully exploiting the operation range of the compressor.

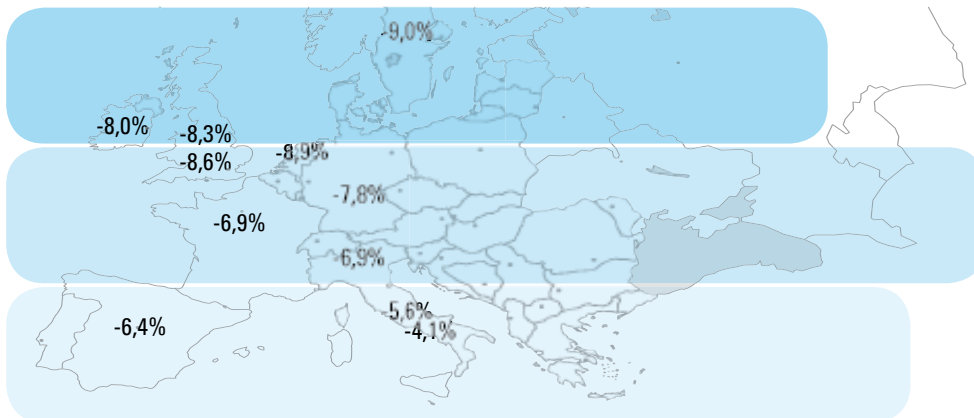
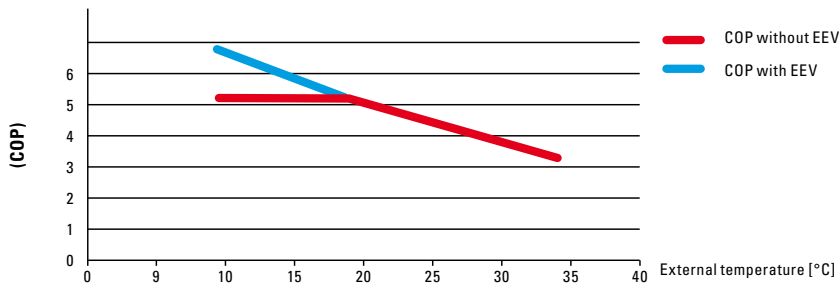

The use of an electronic expansion valve allows the **superheating** to be controlled in all operating conditions, avoiding the characteristic surges which are typical of a mechanical thermostatic valve thanks to dedicated adjustment as well as precise monitoring of the evaporating pressure/temperature increasing the reliability of the unit.

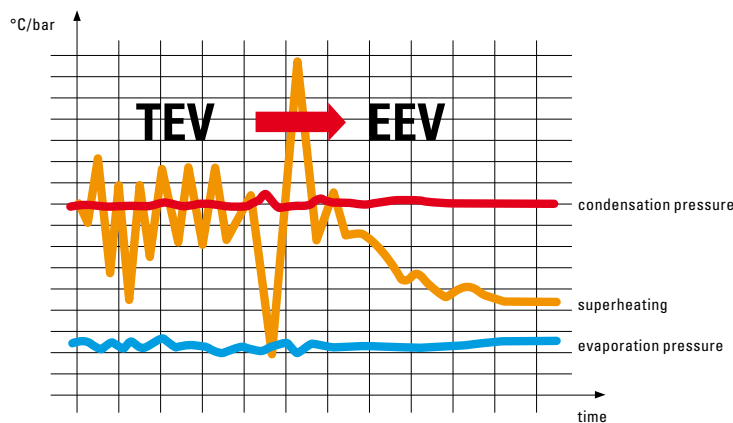

EN 5. ELECTRONIC EXPANSION VALVE AND INTEGRATED DEHUMIDIFICATION IN THE MICROPROCESSOR CONTROL

MERCURY™ units control and optimise **dehumidification** by operating on two control parameters which guarantee that the dehumidification process is carried out with a constant air flow without partializing the evaporating coil. This aspect enables the air distribution to be optimised within the room and for it not to be disturbed during the dehumidification stage. This system enables, therefore, hot spots to be avoided during the various operating stages. In this way dehumidification is carried out by making use of the complete surface of the evaporating coil therefore treating all of the air which passes through it, with a shorter duration dehumidification cycle and a consequent increase in efficiency of the unit. The parameters used are:

SHeat Stp

Indicates the set point for superheating adjustment. This parameter is set at 6°C in standard operation. When requested by the dehumidifier this value changes and is set at 20°C.

LOP limit

Low suction pressure thresholds (LOWEST OPERATING PRESSURE) indicate the saturated °C. This parameter defines the intervention threshold of the low pressure protection: below this value an integral adjustment is activated with a constant which can be set in order to bring the temperature back to, and keep it at, the temperature above the threshold.

With the request from the dehumidifier, the low pressure threshold is lowered to 3°C. The increase in supercooling decreases evaporation which leads to significantly lower values than that at standard operation. In these conditions the cooling capacity of the unit does not significantly decrease while the latent heat increases which leads to a decrease in humidity. If there is a dual circuit, only the compressor of circuit C1 is ON. If there is a dual circuit which has tandem compressors both compressors are on.

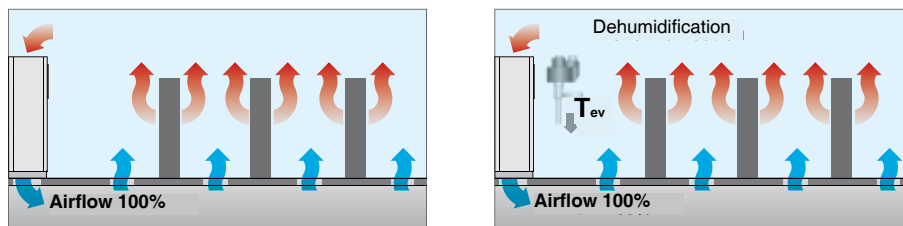

6. Electronically commutated fans (EC)

Electronically commutated “EC” fans, based on “Brushless” technology, create substantial advantages in terms of:

- reliability;
- lower absorbed power compared to a traditional motor;
- performance: thanks to the latest generation special blade design they can maintain a higher air flow along with minimum noise levels;
- lower inrush current, thanks to “Soft Start” start-up;
- flexibility of use, thanks to a wide range of voltages;
- flexibility of application, thanks to continuous regulation of the rotation speed by the microprocessor.

The EC motor is synchronized with permanent magnets which are electronically commutated. The commutation is made by a power transistor, therefore there are no mechanical elements such as a collector or brushes which would noticeably reduce the life span. In EC motors the magnetic field is generated by the same rotor thanks to the presence of permanent magnets. The commutation of the magnetic field is electronic and consequently free of wear and tear resulting from contact between static and rotating parts. The operating mode and the materials used lead to an increased efficiency which is shown in less absorption with the same performance.

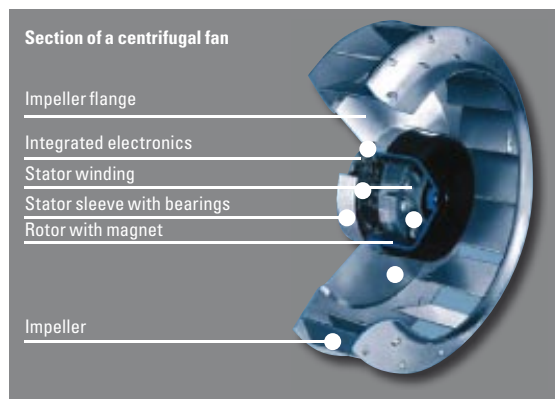
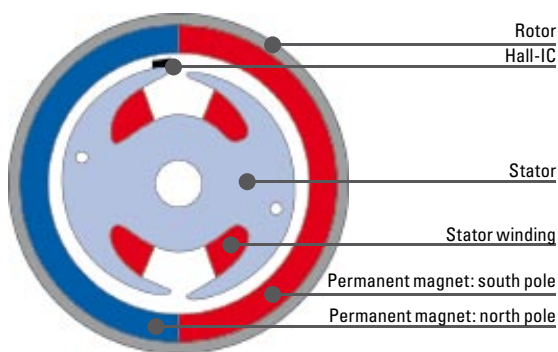

This type of fan is combined with a fluid dynamics study which allows performance and noise levels to be optimised.

Electronically commutated motors also allow the advantages of “soft start” which means lower inrush currents compared to nominal values. The voltage range is much wider than that which is available for traditional motors and due to a 0-10V input these fans can be regulated continuously which means that the speed can be selected from the user terminal. The advantages created by EC fans applied to MERCURY™ units leads to both a reduction in the absorbed power with the same performance compared to the same unit equipped with traditional fans as well as an increase in performance in terms of available air flow and static.

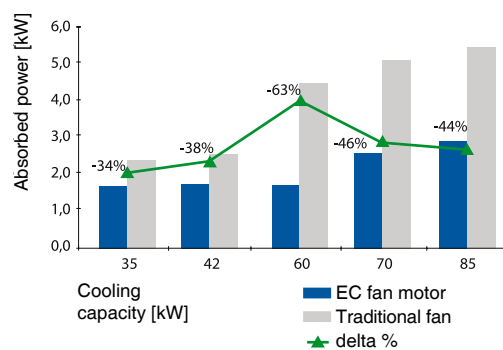
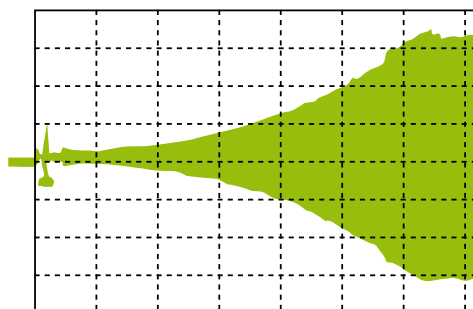

7. Configurations with Tandem compressors

The MERCURY™ direct expansion range offers for the same range of capacities the possibility of selecting from the different refrigerant circuit configurations a bi-circuit equipped with tandem compressors for each circuit which creates better efficiency and regulation capacity at partial loads. The exchange surfaces are constant and sized for the combined power of both the compressors; this leads, when the circuit of one of the compressors is switched off, to a reduction in the thermal gradients of the exchangers which creates high efficiency during partial loads. The variation in the refrigerant load, obtained by switching off a compressor on one of the two twin circuits, decreases the condensation pressure and increases that of the evaporator, while the surfaces of the exchangers (evaporator and condenser) remain the same with a consequent increase in the COP.

In order to be able to measure efficiency also at partial loads, several parameters have been introduced which take the COPs at 25%, 50%, 75% and at 100% into consideration with average weighting. These parameters (IPLV: Integrated Partial Load Value, EMPE: Average Weighted Efficiency in Summer Mode, ESEER: European Seasonal Energy Efficiency Ratio) differ in the weights and working conditions from which the different COPs are calculated, but they can be associated with the following calculation:

$$\frac{(W_{100\%} \times COP_{100\%}) + (W_{75\%} \times COP_{75\%}) + (W_{50\%} \times COP_{50\%}) + (W_{25\%} \times COP_{25\%})}{100}$$

Tandem / Double circuit	T	D	T	D	T	D
Cooling capacity [kW]	25	25	35	35	45	45
COP	3.2	3.2	3.3	3.3	3.6	3.6
ESEER	4.0	3.5	4.1	3.6	4.3	4.0

Comparison of part-load efficiencies for DXA units(EDAB)

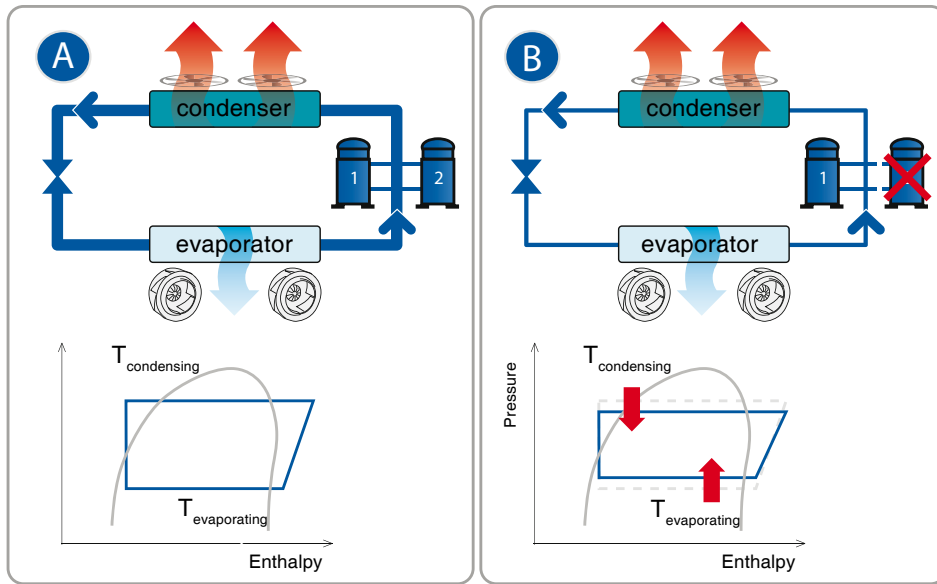
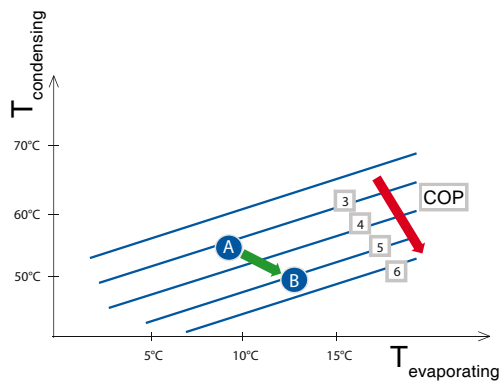

fig. A - 100% operation

fig. B - part load operation



8. R410A environmentally friendly refrigerant

R410A / Efficiency

R410A gas, whose behaviour is almost azeotropic, is characterised by absence of the glide during state changing phases, which thus occur at a constant pressure without energy loss. As a result of greater thermal exchange capacity (greater intrinsic efficiency) and a considerable reduction in pressure drops it is possible to optimise the unit increasing efficiency and effectiveness. Performance levels are maintained over the years, and do not decrease due to separation of the gas components. In fact, eventual refrigerant losses, with the necessary integrations, can be managed quickly and efficiently without having to completely replace the refrigerant, thus the initial composition remains unvaried.

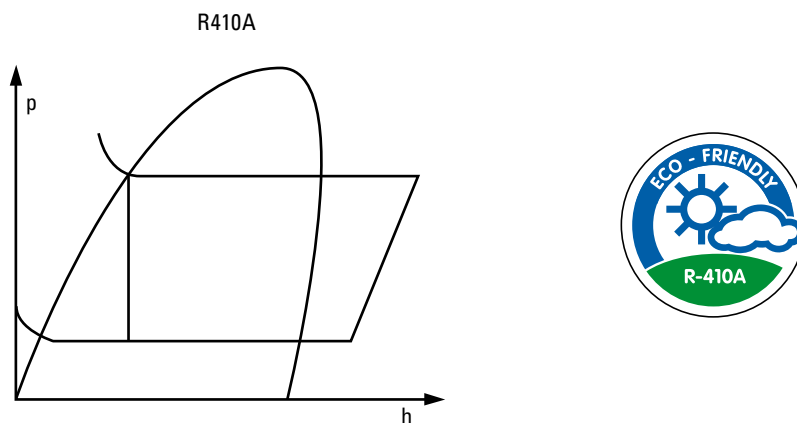

R410A / Respect for the environment

All synthetic refrigerants damage the ozone and contribute to increasing the temperature of our planet, thus playing a role in increasing the greenhouse effect.

R410A gas, an equicomponent mix of R32 and R125 with the lack of chlorine guarantees an environmentally-friendly, efficient and reliable operation of conditioning systems.

Parameters have been set to determine the environmental impact of different kinds of refrigerant:

- **ODP** Ozone Depletion Potential: can register a value between 0 and 1 (CFC-R12 = 1)
- **GWP** Global Warming Potential: the relationship between the overall warming caused by a particular substance and the one cause by CO₂ carbon dioxide.
- **TEWI** Total Equivalent Warming Impact: parameter relating to the emission of refrigerant during the unit life-cycle, and the indirect emissions of CO₂ for energy production.

It is, in fact, important to assess the environmental impact of a given substance, not only intrinsically, that is, considering its chemical-physical features only, but also its application and effects during the entire duration of use.

In cooling devices, most of the contribution to the greenhouse effect (approximately 90%, if not more) is caused by energy consumption, or better, in indirect terms, to the amount of CO₂ produced by power plants for supplying the energy necessary for operating the device.

It is thus essential to consider the energy consumption of a unit, and its ability to guarantee and maintain high energy efficiency during the entire product life-cycle.

The TEWI index considers both the direct impact a substance has on the greenhouse effect, and its indirect contribution in terms of CO₂ equivalent.

It takes the following points into account:

- refrigerant losses
- energy efficiency
- refrigerant recycling

Consequently, from the point of view of energy efficiency, the kWh consumed by the unit must be calculated and converted into CO₂ produced. **The higher the unit COP (or EER), the lower the environmental impact at the same cooling capacity.**

This is the addition of the most significant TEWI when dealing with cooling equipment, which takes into account the indirect contribution to the greenhouse effect. This component of the TEWI varies from country to country as the kWh → CO₂ conversion coefficient depends on the power plants considered and the amount of fossil fuel they use. Refrigerant losses must obviously be kept to a minimum and unit energy efficiency maintained. In the case of non azeotropic refrigerants, loss of part of the fluid leads to the complete recharging of the cooling circuit, and it will not necessarily maintain the declared efficiency. As the R410A is an almost azeotropic mix, it is possible to refill the circuit even with small quantities and maintain energy efficiency for longer, improving both the direct and indirect contribution. Thus, even though the GWP may be aligned with the other refrigerants, the R410A clearly has a better TEWI, guaranteeing both greater respect for the environment and sustainability.

8. R410A ENVIRONMENTALLY FRIENDLY REFRIGERANT

EN 9. SUPERVISORY

TEWI =	$m \times L \times n \times GWP$	+	$\beta \times E \times n$	+	$m \times (1-\delta) \times GWP$
	refrigerant losses		unit efficiency		recycle
		unit related factors			maintenance related factors

Key:

- m: refrigerant charge in kg
- L: % annual loss of refrigerant
- n: product lifespan in years
- GWP: global warming potential in kg CO₂/kg
- β: emission of CO₂ in the power plant for each kWh produced
- E: annual energy consumed in kWh/year
- δ: refrigerant recovery factor at end of life
(δ=0.....no recovery; δ=1.....total recovery)

As shown in the table below, using R410A means:

- Ozone Depletion Potential (ODP) = absent
- Global Warming Potential (GWP) = in line with other refrigerants
- Total Equivalent Warming Impact (TEWI) = lower (-14% versus R407C)

Refrigerant	Type	ODP	GWP	TEWI (*)	
R22	HCFC	0.05	1700	1968	(-3% Vs R407C)
R134	HFC	0	1300	1821	(-10% Vs R407C)
R407C	HFC	0	1600	2032	
R410A	HFC	0	1900	1756	(-14% Vs R407C)

(*) Per year, specific (each kW, each year), with total refrigerant recovery factor at end of life (δ=1)

9. Supervisory

MERCURY™ units have been developed and designed so that they can be inserted within a network which is managed by a supervision system. They are therefore compatible with the most common external BMS (Building Management Systems).

Compatibility with external BMS

BMS on serial networks

- **Modbus:** No limit on the number of units connected, each one has a RS485 serial card
- **Bacnet:** Max 8 units, each one has a RS485 serial card, connected to a Bacnet Gateway
- **LONworks:** No limit on the number of units connected, each one has a FTT10 card
- **TREND:** possible with TREND card
- **Metasys:** possible with integration of the database and Application Note JCI

BMS on TCP/IP (UTP) networks

- **SNMP:** Max 16 units, each one has a RS485 serial card, connected to a Webgate
- **SNMP:** No limit on the number of units connected, each one has a TCP/IP (Pcoveb)
- **Bacnet:** No limit on the number of units connected, each one has a TCP/IP
- **HTML:** No limit on the number of units connected, each one has a TCP/IP



		EDC - EUC						
MODEL		0070	0100	0120	0170	0200	0250	0270*
SUPPLY VOLTAGE		400V/3N/50Hz (8)						
DIMENSIONS								
Height	mm	1960	1960	1960	1960	1960	1960	1960
Width	mm	1010	1310	1310	1720	2170	2170	2170
Depth	mm	750	865	865	865	865	865	865
Weight (Full version) (1)	Kg	240	344	352	425	477	492	492
EU4 FILTERS (2)								
Number	-	2	2	3	3	2 + 2	2 + 3	2 + 3
Front dimension (3)	mm	446 x 980	376 x 980	376 x 980	376 x 980 410 x 845	376 x 980 410 x 845	407 x 1120	407 x 1120
Depth	mm	75	100	100	100	100	100	100
Total filtering area	m ²	2,04	2,76	2,76	4,53	6,24	6,24	6,24
EU4 FILTERS(4)								
Number	-	2	3	3	4	5	5	5
Front dimensions (3)	mm	446 x 980	398 x 1120	398 x 1120	398 x 1120	398 x 1120	398 x 1120	398 x 1120
Depth	mm	75	100	100	100	100	100	100
Total filtering area	m ²	2,04	3,40	3,40	4,53	5,82	5,82	5,82
COOLING COIL								
Frontal area	m ²	0,81	1,24	1,24	1,69	2,18	2,18	2,18
WATER CIRCUIT CAPACITY								
	dm ³	10,25	12,80	15,90	21,60	22,70	28,80	34,90
3 - way valve	-	-	-	-	-	-	-	-
Valve size	-	1 1/4"	1 1/4"	1 1/2"	2"	2"	2"	2"
Kvs coefficient	-	16	16	22	30	30	30	30
COOLING CAPACITY								
Chilled water at 7/12°C								
Total/Sensible (5)	kW	26,9/24,8	33,8/32,8	43,0/40,3	58,1/54,5	69,0/64,8	89,4/81,2	99,9/85,4
Chilled water flow (5)	l/h	4612	5794	7361	9957	11815	15311	17109
Pressure drop (6)	kPa	61	42	65	64	62	76	96
CHILLED WATER AT 10/15°C								
Total/Sensible (5)	kW	19,8/19,8	24,8/24,8	31,6/31,6	42,6/42,6	50,6/50,6	65,3/65,3	75,6/75,6
Chilled water flow (5)	l/h	3388	4257	5410	7313	8672	11190	12966
Pressure drop(6)	kPa	34	24	36	35	35	42	57
FANS								
Type	-	B	B	B	B	B	B	B
Number of fans	n°	1	1	1	2	2	2	2
Air flow rate @ 20 Pa	m ³ /h	6124	10291	10743	15178	18841	18592	18929
Nominal supply voltage	V	230	400	400	400	400	400	400
Fan speed regulation	V	210	310	340	270	300	300	280
Max. static head pressure (7)	Pa	112	251	174	403	314	314	373
FANS								
Type	-	V	V	V	V	V	V	V
Number of fans	n°	1	1	1	2	2	2	2
Air flow rate @ 20 Pa	m ³ /h	6201	10200	10700	15000	18800	18800	18800
Nominal supply voltage	V	400	400	400	400	400	400	400
Fan speed regulation	V	63	71	79	66	81	84	73
Max. static head pressure (7)	Pa	331	397	300	468	193	170	271

(1) D version + electrical heaters

(2) Upflow models with back air suction

(3) Each element

(4) Upflow models with front or bottom air suction and Downflow models

(5) Room 24°C - 50% R.H. 0% glycol

(6) Valve pressure drop included

(7) At nominal air flow rate and max. fan speed

(8) C version unit + Electrical heaters / D / D + electrical heaters

(*) Downflow only

MODEL	EDC - EUC							
		0070	0100	0120	0170	0200	0250	0270*
ELECTRIC HEAT								
Number of stages	-	1	1	3	3	3	3	3
STANDARD CAPACITY								
Number of elements	-	2	2	3	3	5	5	5
Total power	kW	6	6	9	9	15	15	15
ENHANCED CAPACITY								
Number of elements	-	3 (13)	3 (13)	5	5	6	6	6
Total power	kW	9	9	15	15	18	18	18
HOT WATER COIL								
Frontal area	m ²	0,73	0,73	1,16	1,16	1,38	1,78	1,78
Coil internal volume	dm ³	2,6	2,6	3,4	3,4	4,4	5,5	5,5
Heating capacity (11)	kW	11,9	12,2	20,8	20,9	24,9	33,1	33,2
Valve size	-	3/4"	3/4"	1"	1"	1"	1"	1"
Water flow at 40/45 °C (11)	l/h	2037	2083	3565	3588	4270	5667	5685
Pressure drop (with valve) (11)	kPa	17	18	34	35	22	34	34
ELECTRODE HUMIDIFIER								
Nominal steam output	Kg/h	5	5	8	8	8	8	8
Nominal power	kW	3,60	3,60	5,77	5,77	5,77	5,77	5,77
FRESH AIR FILTER								
Connection diameter	mm	100	100	100	100	100	100	100
Nominal Flow rate	m ³ /h	130	130	130	130	130	130	130
CONDENSATE DRAIN PUMP (12)								
Nominal water flow (C version)	l/h	500	500	500	500	500	500	500
Nominal water flow (D version)	l/h	900	900	900	900	900	900	900

(11) Room at 20°C - 20 Pa External Static Pressure

(12) Nominal water flow with 30 kPa head Pressure

(13) 10 - 100% Modulating

(*) downflow only

		EDC	
MODEL		0340	0400
SUPPLY VOLTAGE		400V/3N/50Hz	
DIMENSIONS			
Height	mm	1960	1960
Width	mm	2580	2580
Depth	mm	865	865
Weight (Full version) (1)	Kg	720	740
EU4 FILTERS (2)			
Number	-	5	5
Front dimension (3)	mm	785 x 486	785 x 486
Depth	mm	150	150
Total filtering area	m ²	7,15	7,15
COOLING COIL			
Frontal area	m ²	3,06	3,06
WATER CIRCUIT CAPACITY			
	l	46,41	58,20
3 - way valve			
Valve size	-	2"	2"
Kvs coefficient	-	30	40
COOLING CAPACITY			
Chilled water at 7/12°C			
Total/Sensible (5)	kW	115,2 / 99,7	127,1 / 108,1
Chilled water flow (5)	l/h	19744	21770
Pressure drop (6)	kPa	83	87
CHILLED WATER AT 10/15°C			
Total/Sensible (5)	kW	88,2 / 88,2	96,5 / 96,5
Chilled water flow (5)	l/h	15125	16540
Pressure drop(6)	kPa	50	53
FANS			
Type	-	B	B
Number of fans	n°	3	3
Air flow rate @ 20 Pa	m ³ /h	24346	25406
Nominal supply voltage	V	400	400
Fan speed regulation	V	280	320
Max. static head pressure(7)	Pa	204	129
FANS			
Type	-	V	V
Number of fans	n°	3	3
Air flow rate @ 20 Pa	m ³ /h	24800	25200
Nominal supply voltage	V	400	400
Fan speed regulation	V	70	73
Max. static head pressure(7)	Pa	406	366

(1) D version + electrical heaters

(2) Upflow models with back air suction

(3) Each element

(4) Room 24°C - 50% R.H. 0% glycol

(5) Valve pressure drop included

(6) At nominal air flow rate and max. fan speed

(*) Downflow only

		EDC	
MODEL		0340	0400
ELECTRIC HEAT			
Number of stages	-	3	3
STANDARD CAPACITY			
Number of elements	-	8	8
Total power	kW	24	24
ENHANCED CAPACITY			
Number of elements	-	9	9
Total power	kW	27	27
HOT WATER COIL			
Frontal area	m ²	2,03	3,03
Coil internal volume	dm ³	7,18	7,18
Heating capacity (11)	kW	40,5	40,5
Valve size	-	2"	2"
Water flow at 40/45 °C (11)	l/h	7233	7233
Pressure drop (with valve) (11)	kPa	35	35
ELECTRODE HUMIDIFIER			
Nominal steam output	Kg/h	15	15
Nominal power	kW	11,80	11,80
FRESH AIR FILTER			
Connection diameter	mm	100	100
Nominal Flow rate	m ³ /h	130	130
CONDENSATE DRAIN PUMP (12)			
Nominal water flow (C version)	l/h	500	500
Nominal water flow (D version)	l/h	900	900

(11) Room at 20°C - 20 Pa External Static Pressure

(12) Nominal water flow with 30 kPa head Pressure

(13) 10 - 100% Modulating

(*) Downflow only

		EDA - EUA							
MODEL		1105	1106	2107	2207	2109	2209	2111	2211
SUPPLY VOLTAGE		400V/3N/50Hz							
DIMENSIONS									
Height	mm	1960	1960	1960	1960	1960	1960	1960	1960
Width	mm	1010	1010	1310	1310	1310	1310	1310	1310
Depth	mm	750	750	865	865	865	865	865	865
Weight (Full version) (1)	Kg	280	280	430	430	430	430	430	430
EU4 FILTERS									
Number	-	2	2	3	3	3	3	3	3
Front dimensions (2)	mm	445x830	445x830	397x845	397x845	397x845	397x845	397x845	397x845
Depth	mm	75	75	100	100	100	100	100	100
Total filtering area	m ²	1,71	1,71	2,51	2,51	2,51	2,51	2,51	2,51
EVAPORATOR COIL									
Frontal area	m ²	0,68	0,68	0,93	0,93	0,93	0,93	0,93	0,93
COMPRESSORS	dm ³	10,25	12,80	15,90	21,60	22,70	28,80	34,90	
Type	-	SCROLL							
Number	-	1	1	1+1	2	1+1	2	1+1	2
Number of refrigerant circuits	-	1	1	1	2	1	2	1	2
COOLING CAPACITY									
Total/Sensible (3)	kW	19,1/19,1	20,9/20,5	24,3/24,3	26,2/26,2	31,8/30,2	34,6/30,6	37,1/36,8	39,1/38,8
FANS									
Type	-	B	B	B	B	B	B	B	B
Number of fans	-	1	1	1	1	1	1	2	2
Air flow rate @ 20 Pa	m ³ /h	5645	5645	8600	8600	8600	8600	13106	13106
Nominal supply Voltage	V	200	200	250	250	250	250	260	260
Max. static head pressure (4)	Pa	157	157	405	405	405	405	432	432
FANS									
Type	-	V	V	V	V	V	V	V	V
Number of fans	-	1	1	1	1	1	1	2	2
Air flow rate @ 20 Pa	m ³ /h	5754	5754	8600	8600	8600	8600	12900	12900
Nominal supply Voltage	V	59	59	70	70	70	70	61	61
Max. static head pressure (4)	Pa	406	406	293	293	293	293	525	525
ELECTRIC HEAT									
Number of stages	-	1	1	3	3	3	3	3	3
STANDARD CAPACITY									
Number of elements	-	2	2	3	3	3	3	3	3
Total power	kW	6	6	9	9	9	9	9	9
ENHANCED CAPACITY									
Number of elements	-	3	3	5	5	5	5	5	5
Total power	kW	9	9	15	15	15	15	15	15

(1) D version + electrical heaters

(2) Each element

(3) Room at 24°C - 50% R.H. - Refrigerant R410A - 45°C
Condensing temperature

(4) Nominal air flow rate and max fan supply voltage

(*) Downflow only

		EDA - EUA							
MODEL		1105	1106	2107	2207	2109	2209	2111	2211
HOT WATER COIL									
Frontal area	m ²	0,64	0,64	0,84	0,84	0,84	0,84	1,15	1,15
Coil internal volume	dm ³	2,3	2,3	3,20	3,20	3,20	3,20	3,70	3,70
Heating capacity (5)	kW	11,9	11,9	15,6	15,6	15,6	15,6	22,5	22,5
Valve size	-	3/4"	3/4"	1"	1"	1"	1"	1"	1"
Water flow at 40/45 °C (5)	l/h	2080	2080	2760	2760	2760	2760	3920	3920
Pressure drop (with valve) (5)	kPa	41	41	41	41	41	41	66	66
HOT GAS COIL									
Heating capacity (6)	kW	13,20	13,20	19,10	9,20	19,10	8,80	22,00	11,50
Frontal area	m ²	0,64	0,64	0,84	0,44	0,84	0,44	1,15	0,61
ELECTRODE HUMIDIFIER									
Nominal steam output	Kg/h	5	5	8	8	8	8	8	8
Nominal power	kW	3,93	3,93	6,29	6,29	6,29	6,29	6,29	6,29
FRESH AIR FILTER									
Connection diameter	mm	100	100	100	100	100	100	100	100
Nominal Flow rate	m ³ /h	130	130	130	130	130	130	130	130
CONDENSATE DRAIN PUMP (7)									
Nominal water flow (C version)	l/h	500	500	500	500	500	500	500	500
Nominal water flow (D version)	l/h	900	900	900	900	900	900	900	900

- (5) Room at 20°C - 20 Pa External Static Pressure
- (6) Dehumidification on - 45°C Condensing temperature
- (7) Nominal water flow with 30 kPa head Pressure

		EDA - EUA								
MODEL		2113	2213	2216	2218	2222 (5)	4222 (5)	2225 (5)	4225 (5)	4228 (5)
SUPPLY VOLTAGE		400V/3N/50Hz								
DIMENSIONS										
Height	mm	1960	1960	1960	1960	2175	2175	2175	2175	2175
Width	mm	1720	1720	2170	2170	2582	2582	2582	2582	2582
Depth	mm	865	865	865	865	865	865	865	865	865
Weight (Full version) (1)	Kg	575	575	714	714	910	910	918	930	1040
EU4 FILTERS										
Number	-	4	4	5	5	5	5	5	5	5
Front dimensions (2)	mm	397x845	397x845	410x845	410x845	785x486	785x486	785x486	785x486	785x486
Depth	mm	100	100	100	100	150	150	150	150	150
Total filtering area	m ²	5,01	5,01	6,47	6,47	7,15	7,15	7,15	7,15	7,15
EVAPORATOR COIL										
Frontal area	m ²	1,26	1,26	1,64	1,64	2,35	2,35	2,35	2,35	2,35
COMPRESSORS	dm ³	10,25	12,80	15,90	21,60	22,70	28,80	34,90		
Type	-	SCROLL								
Number	-	2	2	2	2	2	4	2	4	4
Number of refrigerant circuits	-	1	2	2	2	2	2	2	2	2
COOLING CAPACITY										
Total/Sensible (3)	kW	40,7/40,7	43,2/42,4	57,6/54,1	61,2/55,4	74,0/73,7	72,7/72,4	86,3/86,3	83,9/83,9	88,1/88,0
FANS										
Type	-	B	B	B	B	B	B	B	B	B
Number of fans	-	2	2	2	2	3	3	3	3	3
Air flow rate @ 20 Pa	m ³ /h	13106	13106	16324	16234	22037	22037	23432	23432	23628
Nominal supply Voltage	V	260	260	260	260	300	300	340	340	360
Max. static head pressure (4)	Pa	432	432	432	432	174	174	99	99	70
FANS										
Type	-	V	V	V	V	V	V	V	V	V
Number of fans	-	2	2	2	2	3	3	3	3	3
Air flow rate @ 20 Pa	m ³ /h	12900	12900	16500	16500	22000	22000	23000	23000	23500
Nominal supply Voltage	V	61	61	72	72	74	74	77	77	80
Max. static head pressure (4)	Pa	525	525	255	255	356	356	320	320	282
ELECTRIC HEAT										
Number of stages	-	3	3	3	3	3	3	3	3	3
STANDARD CAPACITY										
Number of elements	-	5	5	5	5	6	6	6	6	8
Total power	kW	15	15	15	15	18	18	18	18	24
ENHANCED CAPACITY										
Number of elements	-	6	6	6	6	8	8	8	8	9
Total power	kW	18	18	18	18	24	24	24	24	27

(1) D version +electrical heaters

(2) Each element

(3) Room at 24°C -50% R.H. - Refrigerant R410A
45°C Condensing temperature

(4) Nominal air flow rate and max fan supply voltage

(5) Downflow only

		EDA - EUA								
MODEL		2113	2213	2216	2218	2222	4222	2225	4225	4228
HOT WATER COIL										
Frontal area	m ²	1,15	1,15	1,15	1,15	2,03	2,03	2,03	2,03	2,03
Coil internal volume	dm ³	3,70	3,70	4,90	4,90	6,50	6,50	6,50	6,50	6,50
Heating capacity (5)	kW	22,5	22,5	28,8	28,8	50,3	50,3	50,3	50,3	50,3
Valve size	-	1"	1"	2"	2"	2"	2"	2"	2"	2"
Water flow at 40/45 °C (5)	l/h	3920	3920	5110	5110	8388	8388	8388	8388	8388
Pressure drop (with valve) (5)	kPa	66	66	45	45	58	58	58	58	58
HOT GAS COIL										
Heating capacity (6)	kW	22,50	12,00	15,80	18,50	22,80	22,80	23,30	23,30	23,70
Frontal area	m ²	1,20	1,20	1,20	1,20	1,20	1,20	1,20	1,20	1,20
ELECTRODE HUMIDIFIER										
Nominal steam output	Kg/h	8	8	8	8	8	8	8	8	8
Nominal power	kW	6,29	6,29	6,29	6,29	6,29	6,29	6,29	6,29	6,29
FRESH AIR FILTER										
Connection diameter	mm	100	100	100	100	100	100	100	100	100
Nominal Flow rate	m ³ /h	130	130	130	130	130	130	130	130	130
CONDENSATE DRAIN PUMP (7)										
Nominal water flow (C version)	l/h	500	500	500	500	500	500	500	500	500
Nominal water flow (D version)	l/h	900	900	900	900	900	900	900	900	900

(5) Room at 20°C - 20 Pa External Static Pressure

(6) Dehumidification on - 45°C Condensing temperature

(7) Nominal water flow with 30 kPa head Pressure

		EDW - EUW							
MODEL		1106	2109	2113	2216	2218	4222 (5)	4225 (5)	4228 (5)
SUPPLY VOLTAGE		400V/3N/50Hz							
DIMENSIONS									
Height	mm	1960	1960	1960	1960	1960	2175	2175	2175
Width	mm	1010	1310	1720	2170	2170	2582	2582	2582
Depth	mm	750	865	865	865	865	865	865	865
Weight (Full version) (1)	Kg	280	430	575	714	714	996	1020	1120
EU4 FILTERS									
Number	-	2	3	4	5	5	5	5	5
Front dimensions (2)	mm	445x830	397x845	397x845	410x845	410x845	785x486	785x486	785x486
Depth	mm	75	100	100	100	100	150	150	150
Total filtering area	m ²	2,15	3,76	5,01	6,47	6,47	7,15	7,15	7,15
EVAPORATOR COIL									
Frontal area	m ²	0,68	0,93	1,26	1,64	1,64	2,35	2,35	2,35
COMPRESSORS	dm ³	10,25	12,80	15,90	21,60	22,70	28,80	34,90	
Type	-	SCROLL							
Number	-	1	2	2	2	2	4	4	4
Number of refrigerant circuits	-	1	1	1	2	2	2	2	2
COOLING CAPACITY									
Total/Sensible (3)	kW	22,6/19,0	33,2/29,9	43,2/41,6	56,3/50,7	62,0/52,3	82,5/82,5	95,6/87,8	102,3/97,1
FANS									
Type	-	B	B	B	B	B	B	B	B
Number of fans	-	1	1	2	2	2	3	3	3
Air flow rate @ 20 Pa	m ³ /h	5634	8600	13106	16324	16324	22037	23432	23628
Nominal supply Voltage	V	200	250	260	260	260	300	340	360
Max. static head pressure (4)	Pa	157	405	432	432	432	174	99	70
FANS									
Type	-	V	V	V	V	V	V	V	V
Number of fans	-	1	1	2	2	2	3	3	3
Air flow rate @ 20 Pa	m ³ /h	5754	8600	12900	16500	16500	22000	23000	23500
Nominal supply Voltage	V	59	70	61	72	72	74	77	80
Max. static head pressure (4)	Pa	406	293	525	255	255	356	320	282
ELECTRIC HEAT									
Number of stages	-	1	3	3	3	3	3	3	3
STANDARD CAPACITY									
Number of elements	-	2	3	5	5	5	6	6	8
Total power	kW	6	9	15	15	15	18	18	24
ENHANCED CAPACITY									
Number of elements	-	3	5	6	6	6	8	8	9
Total power	kW	9	15	18	18	18	24	24	27

- (1) D version +electrical heaters
(2) Each element
(3) Room at 24°C -50% R.H. - Refrigerant R410A
Outlet/inlet water temperature 35/30°C
(4) Nominal air flow rate and max fan supply voltage
(5) Down flow only

		EDW - EUW								
MODEL		1106	2109	2113	2216	2218	4222	4225	4228	4228
HOT WATER COIL										
Frontal area	m ²	0,64	0,84	1,15	1,49	1,49	2,03	2,03	2,03	2,03
Coil internal volume	dm ³	2,31	3,20	3,70	4,90	4,90	6,50	6,50	6,50	6,50
Heating capacity (5)	kW	12,0	15,6	22,5	28,8	28,8	50,3	50,3	50,3	50,3
Valve size	-	3/4"	1"	1"	2"	2"	2"	2"	2"	2"
Water flow at 40/45 °C (5)	l/h	2020	2760	3920	5110	5110	8388	8388	8388	8388
Pressure drop (with valve) (5)	kPa	40	41	66	45	45	58	58	58	58
HOT GAS COIL										
Heating capacity (6)	kW	13,20	19,10	22,50	15,80	16,50	22,80	23,30	23,30	23,70
Frontal area	m ²	0,64	0,84	1,15	0,77	0,77	1,20	1,20	1,20	1,20
ELECTRODE HUMIDIFIER										
Nominal steam output	Kg/h	5	8	8	8	8	8	8	8	8
Nominal power	kW	3,93	6,29	6,29	6,29	6,29	6,29	6,29	6,29	6,29
FRESH AIR FILTER										
Connection diameter	mm	100	100	100	100	100	100	100	100	100
Nominal Flow rate	m ³ /h	130	130	130	130	130	130	130	130	130
CONDENSATE DRAIN PUMP (7)										
Nominal water flow (C version)	l/h	500	500	500	500	500	500	500	500	500
Nominal water flow (D version)	l/h	900	900	900	900	900	900	900	900	900

(5) Room at 20°C - 20 Pa External Static Pressure
 (6) Dehumidification on - 45°C Condensing temperature
 (7) Nominal water flow with 30 kPa head Pressure

For performances at operating conditions different from the nominal ones, please use the selection software Pitagora.

Dimensions of the air delivery section

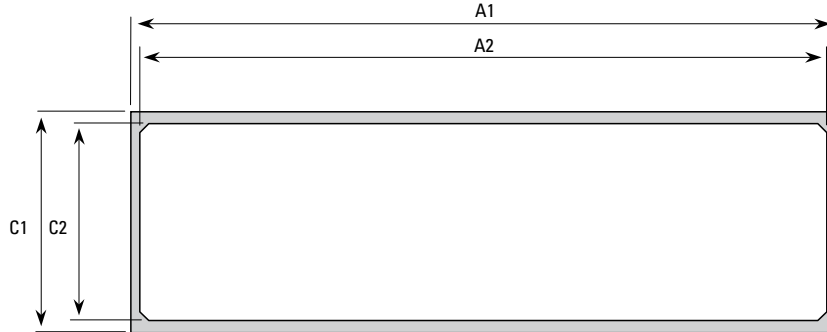

		EDC - EUC					
		0070	0100 - 0120	0170	0200 - 0250 0270	0340	0400
A1	mm	1000	1300	1710	2161	2572	2572
A2	mm	900	1200	1610	2061	2492	2492
C1	mm	740	855	855	855	855	855
C2	mm	653	770	770	770	775	775

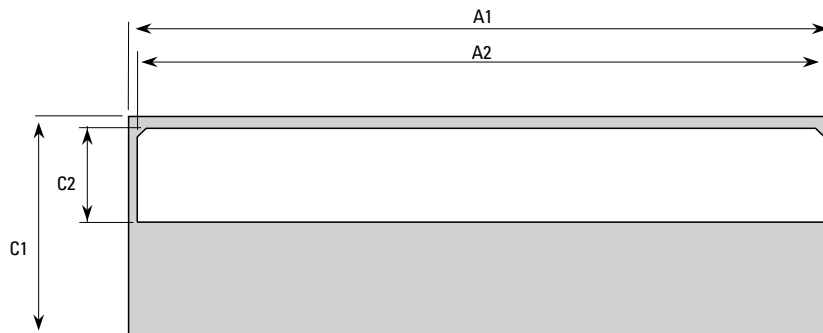

		EDA - EDW				
		1105 - 1106	2107 - 2207 2109 - 2209	2111 - 2211 2113 - 2213	2216 - 2218	2222 - 4222 - 2225 4225 - 4228
A1	mm	1000	1300	1710	2161	2572
A2	mm	900	1200	1610	2061	2492
C1	mm	740	855	855	855	855
C2	mm	280	325	325	325	406

EN DIMENSIONS OF THE AIR DELIVERY SECTION

Dimensions of the air delivery section

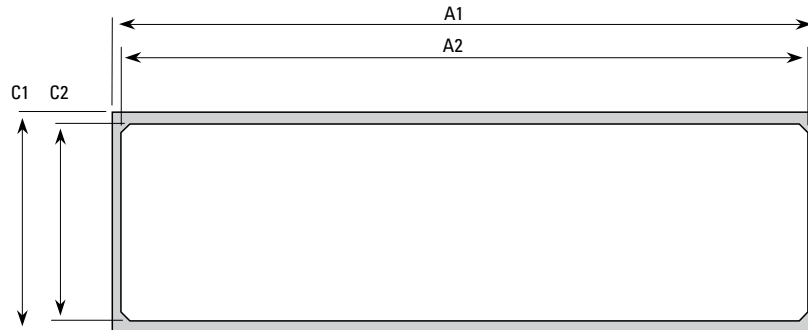

		EUA - EUW			
		1105 - 1106	2107 - 2207 2109 - 2209	2111 - 2211 2113 - 2213	2216 - 2218
A1	mm	1000	1300	1710	2161
A2	mm	900	1200	1610	2061
C1	mm	740	855	855	855
C2	mm	653	770	770	770

CONNECTIONS

Chilled water models

MODEL	EDC - EUC						
	0070	0100	0120	0170	0200	0250 0270	0340 0400
Chilled water - inlet	1" GAS F	1¼" GAS F	1¼" GAS F	1½" GAS F	2" GAS F	2" GAS F	2" GAS F
Chilled water - outlet	1" GAS F	1¼" GAS F	1¼" GAS F	1½" GAS F	2" GAS F	2" GAS F	2" GAS F
Condenser drain (1)	21	21	21	21	21	21	21
Condenser drain with optional pump (1)	3/8" FNPT	3/8" FNPT	3/8" FNPT	3/8" FNPT	3/8" FNPT	3/8" FNPT	3/8" FNPT
Humidifier power supply (optional)	6	6	6	6	6	6	6
Humidifier drain (optional) (2)	32	32	32	32	32	32	32
Humidifier drain with optional pump (2)	3/8" FNPT	3/8" FNPT	3/8" FNPT	3/8" FNPT	3/8" FNPT	3/8" FNPT	3/8" FNPT
Hot water (optional) - inlet	¾" GAS M	¾" GAS M	¾" GAS M	1¼" GAS M	1¼" GAS M	1¼" GAS M	1¼" GAS M
Hot water (optional) - outlet	¾" GAS M	¾" GAS M	¾" GAS M	1¼" GAS M	1¼" GAS M	1¼" GAS M	1¼" GAS M

Optional
 (1) Only C versions
 (2) Only D versions

Direct expansion

FRAME 3	
MODEL	1105 - 1106
Condenser drain (1)	21
Condenser drain with optional pump (1)	3/8" FNPT
Humidifier power supply (optional)	6
Humidifier drain (optional) (2)	32
Humidifier drain with optional pump (2)	3/8" FNPT
Hot water (optional) - inlet	3/4" GAS M
Hot water (optional) - outlet	3/4" GAS M
CONNECTIONS	
EDA - EUA	
Liquid connection - inlet	16 mm
Gas connection - outlet	16 mm
EDW - EUW	
Water cooled condenser - inlet	1"
Water cooled condenser - outlet	1"



FRAME 4				
MODEL	2107	2207	2109	2209
Condenser drain (1)	21	21	21	21
Condenser drain with optional pump (1)	3/8" FNPT	3/8" FNPT	3/8" FNPT	3/8" FNPT
Humidifier power supply (optional)	6	6	6	6
Humidifier drain (optional) (2)	32	32	32	32
Humidifier drain with optional pump (2)	3/8" FNPT	3/8" FNPT	3/8" FNPT	3/8" FNPT
Hot water (optional) - inlet	3/4" GAS M	3/4" GAS M	3/4" GAS M	3/4" GAS M
Hot water (optional) - outlet	3/4" GAS M	3/4" GAS M	3/4" GAS M	3/4" GAS M
CONNECTIONS				
EDA - EUA				
Liquid connection - inlet	16 mm	16 mm	16 mm	16 mm
Gas connection - outlet	22 mm	16 mm	22 mm	16 mm
EDW - EUW				
Water cooled condenser - inlet	1 1/4"	2 x 1/4"	1 1/4"	2 x 1/4"
Water cooled condenser - outlet	1 1/4"	2 x 1/4"	1 1/4"	2 x 1/4"

Optional
 (1) Only C versions
 (2) Only D versions

Direct expansion



		FRAME 5			
MODEL	2111	2211	2113	2213	
Condenser drain (1)	21	21	21	21	
Condenser drain with optional pump (1)	3/8" FNPT	3/8" FNPT	3/8" FNPT	3/8" FNPT	
Humidifier power supply (optional)	6	6	6	6	
Humidifier drain (optional) (2)	32	32	32	32	
Humidifier drain with optional pump (2)	3/8" FNPT	3/8" FNPT	3/8" FNPT	3/8" FNPT	
Hot water (optional) - inlet	3/4" GAS M	3/4" GAS M	3/4" GAS M	3/4" GAS M	
Hot water (optional)- outlet	3/4" GAS M	3/4" GAS M	3/4" GAS M	3/4" GAS M	
CONNECTIONS		EDA - EUA			
Liquid connection - inlet	16 mm	16 mm	16 mm	16 mm	
Gas connection - outlet	22 mm	16 mm	22 mm	16 mm	
		EDW - EUW			
Water cooled condenser - inlet	1 1/4"	2 x 1/4"	1 1/4"	2 x 1/4"	
Water cooled condenser - outlet	1 1/4"	2 x 1/4"	1 1/4"	2 x 1/4"	



		FRAME 6	
MODEL	2216	2218	
Condenser drain (1)	21	21	
Condenser drain with optional pump (1)	3/8" FNPT	3/8" FNPT	
Humidifier power supply (optional)	6	6	
Humidifier drain (optional) (2)	32	32	
Humidifier drain with optional pump (2)	3/8" FNPT	3/8" FNPT	
Hot water (optional) - inlet	3/4" GAS M	3/4" GAS M	
Hot water (optional)- outlet	3/4" GAS M	3/4" GAS M	
CONNECTIONS		EDA - EUA	
Liquid connection - inlet	16 mm	16 mm	
Gas connection - outlet	22 mm	22 mm	
		EDW - EUW	
Water cooled condenser - inlet	2 x 1/4"	2 x 1/4"	
Water cooled condenser - outlet	2 x 1/4"	2 x 1/4"	

Optional
 (1) Only C versions
 (2) Only D versions

Direct expansion



FRAME 7	
MODEL	2222 - 4222 - 2225 - 4225 - 4228
Condenser drain (1)	21
Condenser drain with optional pump (1)	3/8" FNPT
Humidifier power supply (optional)	6
Humidifier drain (optional) (2)	32
Humidifier drain with optional pump (2)	3/8" FNPT
Hot water (optional) - inlet	3/4" GAS M
Hot water (optional)- outlet	3/4" GAS M
CONNECTIONS	
EDA	
Liquid connection - inlet	16 mm
Gas connection - outlet	22 mm
EDW	
Water cooled condenser - inlet	1" 1/2
Water cooled condenser - outlet	1" 1/2

Optional
 (1) Only C versions
 (2) Only D versions

EN AIR-COOLED UNITS: SUGGESTED REFRIGERATION PIPING

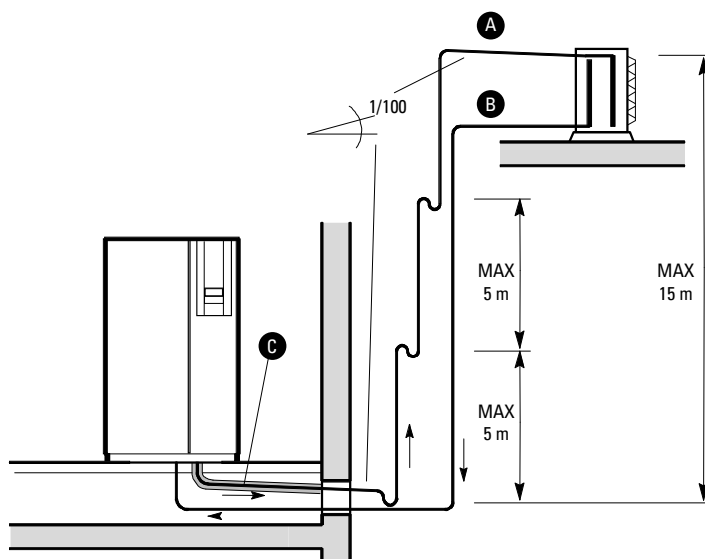
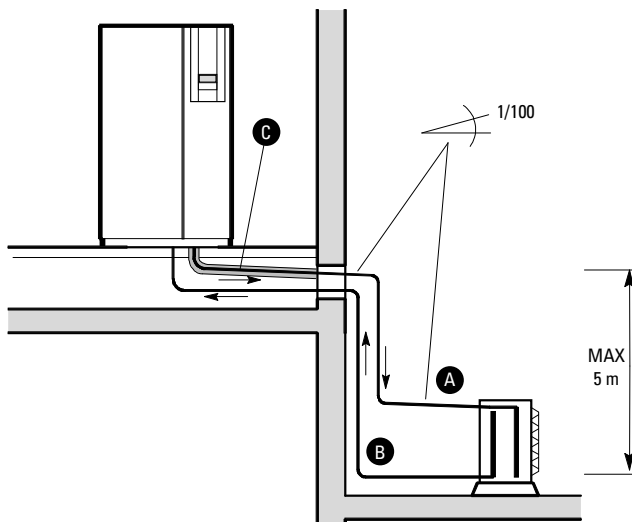
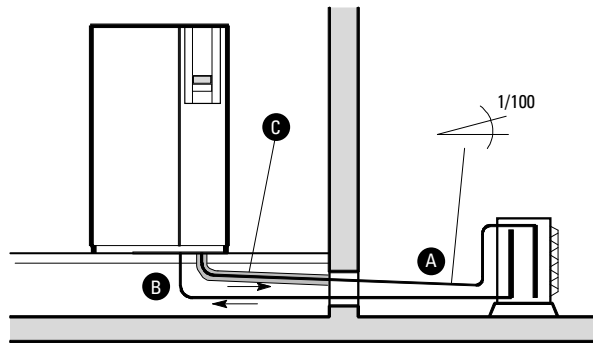

- A) Discharge line
- B) Liquid line
- C) Thermal insulation

The discharge line should be sized in order to ensure oil dragging, especially at partial load operation, to prevent the return of condensed refrigerant and oil to the compressor and to avoid excessive noise or vibration due to hot gas pulses, compressor vibration, or both.

Even though it would be preferable to have low pressure drops along the line, it is important to note that an oversized hot gas line can reduce a reduction in refrigerant speed to the point where the oil is not dragged correctly. Therefore, when using multiple compressors, hot gas lines must transport oil at all possible loadings. Minimum pipe size for oil entrainment in hot gas line are shown in Chart 1-2 for horizontal and vertical lines. In some installations with multiple compressors a vertical hot gas line, sized to transport oil at minimum load, has an excessive pressure drop at maximum load. When this problem exists a larger pipe size and an oil separator can be used. A discharge line pressure drop causes an increase in condensing temperature and consequently a decrease in the unit's cooling capacity. Every percentage decrease in cooling capacity corresponding to 1°C decrease in maximum external operating temperature.

Systems are normally designed so that the pressure drop in the discharge line is not greater than that corresponding to a decreasing of 3% in efficiency.

Discharge line - horizontal line
Chart 1

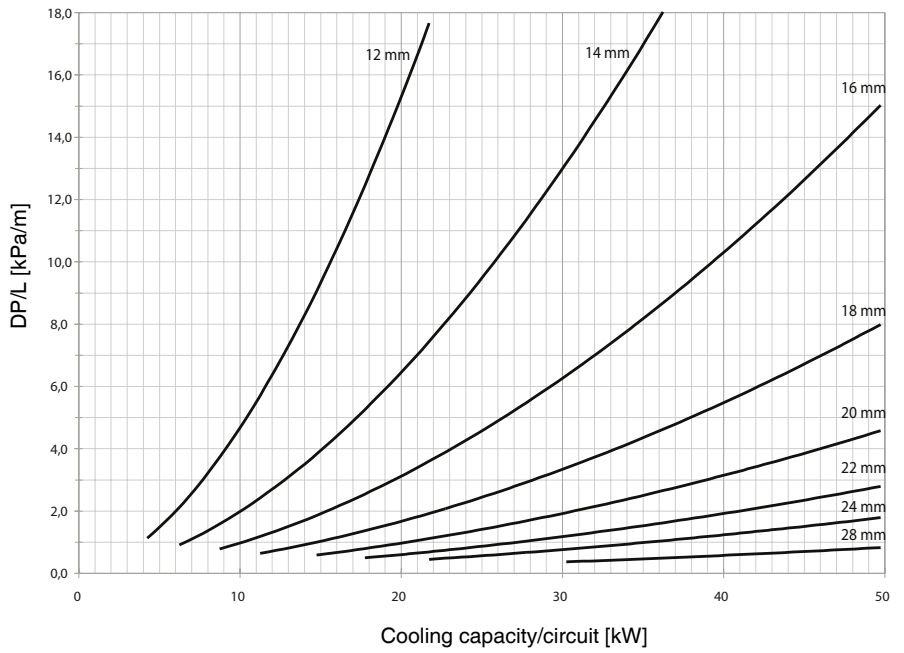
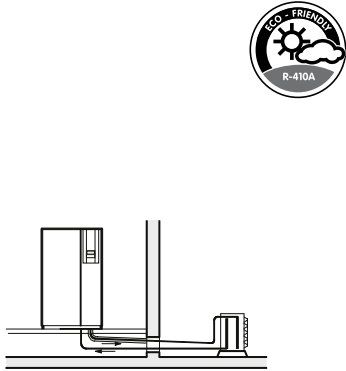

Discharge line - horizontal line
Chart 2

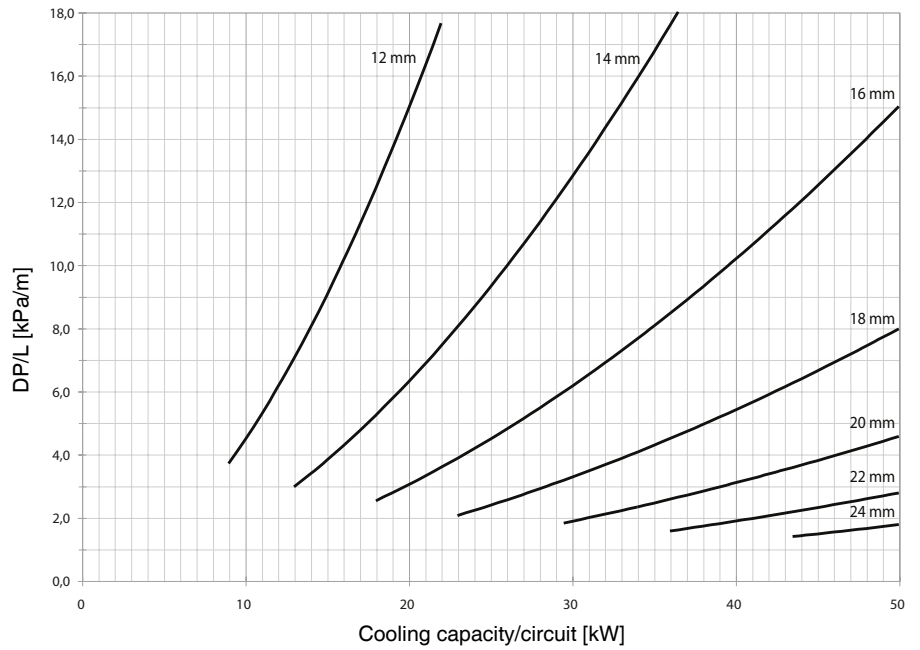
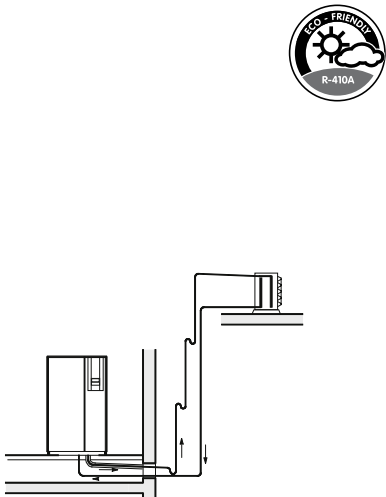

DP/L: Pressure drop per metre based on R410A

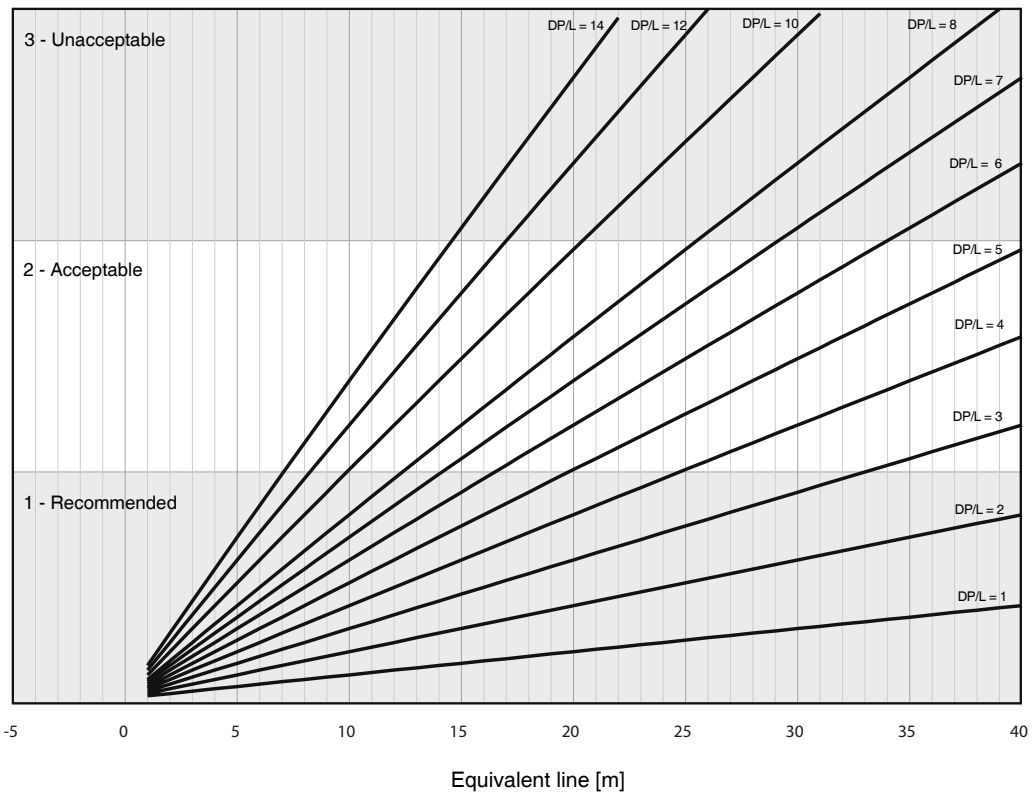

Conforming to the Standards EN14276-1 and EN14276-2 the minimum recommended thickness for the gas supply pipe where bends are made for the air cooled units with R410A refrigerant, must be equal to the values present in the attached table below. The value 'R' refers to the minimum allowed radius of the bend.

External Diameter	Radius of the Bend	Thickness
De (mm)	r [mm]	t [mm]
28	100	1,2
22	66	1
18	27	1
16	26	1
12	20	1

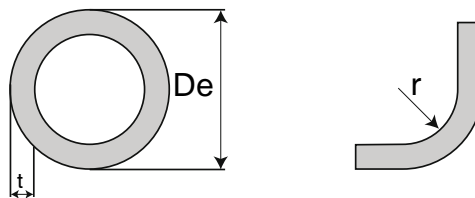

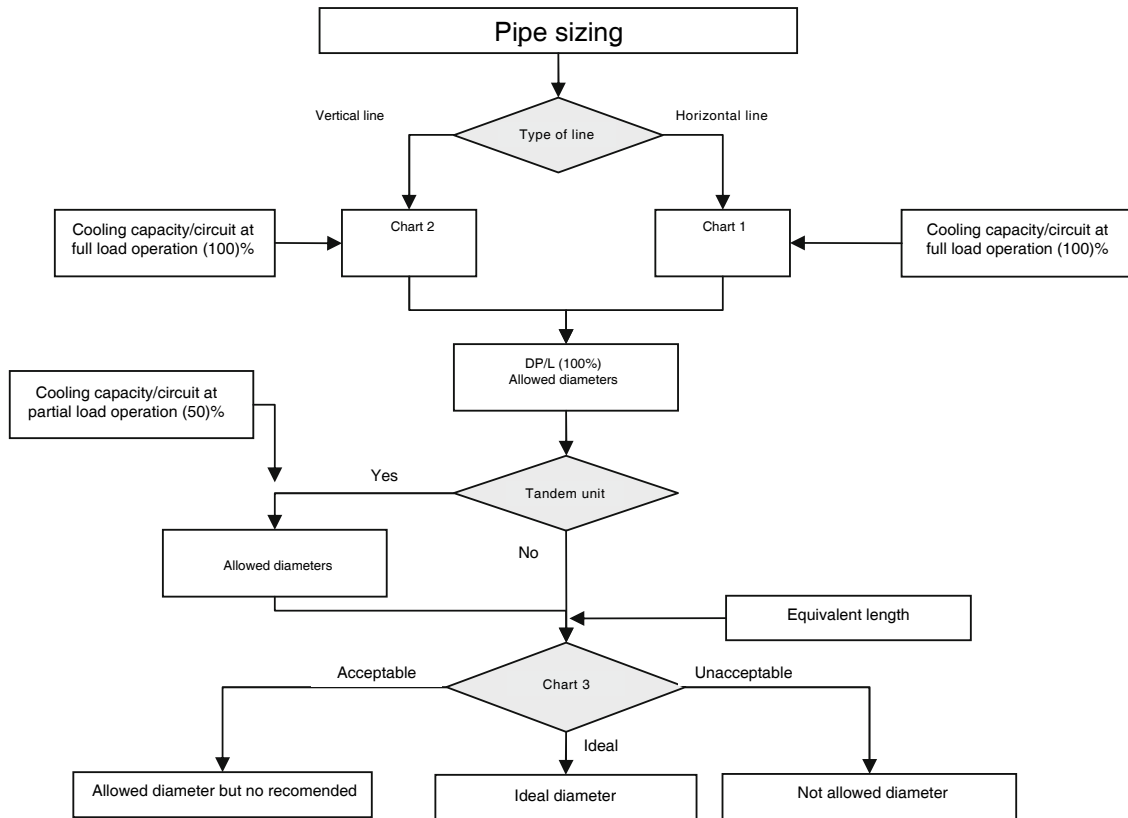

**Example
Discharge line sizing**

Selected air conditioner: EDAB2107A
 Cooling capacity per circuit: 24 kW
 Discharge line: vertical
 Discharge line equivalent length: 20 m

1) Chart (2):

Full load 100%
 (2 compressors on - Cooling capacity per circuit = 24 kW):
 20 mm → DP/L = 1,5 kPa/m
 18 mm → DP/L = 2,2 kPa/m
 16 mm → DP/L = 4,1 kPa/m
 14 mm → DP/L = 8,8 kPa/m
 Partial load 50%
 (1 compressor on Cooling capacity per circuit ≈ 12 kW): available pipe size:
 16 mm → DP/L = 2,1 kPa/m
 14 mm → DP/L = 3,0 kPa/m

2) Chart (3):

Full load 100% (2 compressors on)
 Pipe size 16 mm → DP/L = 4,1 kPa/m → Acceptable
 Pipe size 14 mm → DP/L = 8,8 kPa/m → Unacceptable

Recommended size:
 14 mm or 16 mm

Liquid line should be sized to avoid excessive pressure drop that can cause gas formations in liquid line, insufficient liquid pressure at the liquid receiver device, or both. Systems are normally designed so that the pressure drop in the liquid line, due to the friction, is not greater than that corresponding to about a 0,5 K to 1 K change in saturation temperature.

It is recommended that a non-return valve be installed in the liquid line between the unit and the external condenser in order to protect the compressor from undesirable liquid refrigerant draining back during start up.

MODEL	EUA* - EDA*							
	1105	1106	2107 2109 2113	2207 2209 2211	2213 2216 2218	2222 4222	2225 4225	4228
Liquid line Outside diameter	1 x 16 mm	1 x 16 mm	1 x 16 mm	2 x 16 mm	2 x 16 mm	2 x 18 mm	2 x 18 mm	2 x 18 mm

Refrigerant R410A
Remote air cooled condenser R410A



EUA* - EDA*						
MODEL	1105	1106	2107	2207	2109	2209
Number / Suggested model (1)(2)	1 x CAP0661	1 x CAP0661	2 x CAP0801	1 x CAP0331	2 x CAP1011	2 x CAP0361

EUA* - EDA*							EDA*				
MODEL	2111	2211	2113	2213	2216	2218	2222	4222	2225	4225	4228
Number / Suggested model (1)(2)	1 x CAP1301	2 x CAP0511	1 x CAP1301	1 x CAP1802 2 x CAP0661	1 x CAP2002 2 x CAP0801	1 x CAP3002 2 x CAP1011	1 x CAP2002 2 x CAP1011	1 x CAP2002 2 x CAP1011	1 x CAP3002 2 x CAP1301	1 x CAP3002 2 x CAP1301	1 x CAP3002 2 x CAP1301

(1) With fan speed control
(2) External temperature = 35°C

Remote dry coolers

EDW* - EUW*		
MODEL	1106	2109
Number / Suggested model	1 x RAL1500	1 x RAL1500
Max outdoor temperature	40,0°C	40,0°C

EDW* - EUW*				EDW*		
MODEL	2113	2216	2218	4222	4225	4228
Number / Suggested model	1 x RAL2300	1 x RAL3600	1 x RAL3600	1 x RAL3600	1 x RAL3600	1 x RAL3600
Max outdoor temperature	43,5°C	44,2°C	43,4°C	44°C	43°C	43°C

Electrical heaters standard

ED / EU.B																									
VERSION C					VERSION C + ELECTRICAL HEATERS					VERSION C + ELECTRICAL HEATERS + DEHUMIDIFICATION					VERSION D					VERSION D + ELECTRICAL HEATERS					
kW	L1	L2	L3	mm ²	kW	L1	L2	L3	mm ²	kW	L1	L2	L3	mm ²	kW	L1	L2	L3	mm ²	kW	L1	L2	L3	mm ²	
1105	6,22	16,7	11,9	11,9	4	6,22	16,7	11,9	11,9	4	12,22	25,4	20,6	20,6	6	10,15	22,4	16,7	16,7	4	12,22	25,4	20,6	20,6	6
1106	7,13	20,5	15,7	15,7	4	7,13	20,5	15,7	15,7	4	13,13	29,2	24,4	24,4	6	11,06	26,2	20,5	20,5	6	13,13	29,2	24,4	24,4	6
2107	9,35	20,5	20,5	20,5	4	9,35	20,5	20,5	20,5	4	18,35	33,5	33,5	33,5	10	15,64	29,6	29,6	29,6	6	18,35	33,5	33,5	33,5	10
2207	9,35	20,5	20,5	20,5	4	9,35	20,5	20,5	20,5	4	15,09	25,9	25,9	25,9	6	15,64	29,6	29,6	29,6	6	15,64	29,6	29,6	29,6	6
2109	11,51	25,9	25,9	25,9	6	11,51	25,9	25,9	25,9	6	20,51	38,9	38,9	38,9	10	17,80	35,0	35,0	35,0	10	20,51	38,9	38,9	38,9	10
2209	11,51	25,9	25,9	25,9	6	11,51	25,9	25,9	25,9	6	16,17	28,6	28,6	28,6	6	17,80	35,0	35,0	35,0	10	17,80	35,0	35,0	35,0	10
2111	15,89	34,4	34,4	34,4	10	15,89	34,4	34,4	34,4	10	30,89	56,1	56,1	56,1	16	22,18	43,5	43,5	43,5	10	30,89	56,1	56,1	56,1	16
2211	15,89	34,4	34,4	34,4	10	15,89	34,4	34,4	34,4	10	25,72	44,2	44,2	44,2	10	22,18	43,5	43,5	43,5	10	25,72	44,2	44,2	44,2	10
2113	17,73	41,9	41,9	41,9	10	17,73	41,9	41,9	41,9	10	32,73	63,6	63,6	63,6	25	24,02	51,0	51,0	51,0	16	32,73	63,6	63,6	63,6	25
2213	17,73	41,9	41,9	41,9	10	17,73	41,9	41,9	41,9	10	26,64	47,9	47,9	47,9	16	24,02	51,0	51,0	51,0	16	24,02	51,0	51,0	51,0	16
2216	21,00	46,1	46,1	46,1	10	21,00	46,1	46,1	46,1	10	28,33	50,0	50,0	50,0	16	27,29	55,2	55,2	55,2	16	27,29	55,2	55,2	55,2	16
2218	22,92	50,7	50,7	50,7	16	22,92	50,7	50,7	50,7	16	29,29	52,3	52,3	52,3	16	29,21	59,8	59,8	59,8	16	29,21	59,8	59,8	59,8	16
2222	26,78	62,4	62,4	62,4	25	26,78	62,4	62,4	62,4	25	34,93	66,2	66,2	66,2	25	33,07	71,5	71,5	71,5	25	33,07	71,5	71,5	71,5	25
4222	29,88	65,6	65,6	65,6	25	29,88	65,6	65,6	65,6	25	36,48	67,8	67,8	67,8	25	36,17	74,7	74,7	74,7	25	36,17	74,7	74,7	74,7	25
2225	31,28	68,2	68,2	68,2	25	31,28	68,2	68,2	68,2	25	37,18	69,1	69,1	69,1	25	37,57	77,3	77,3	77,3	25	37,57	77,3	77,3	77,3	25
4225	33,48	76,0	76,0	76,0	25	33,48	76,0	76,0	76,0	25	33,48	76,0	76,0	76,0	25	39,77	85,1	85,1	85,1	35	39,77	85,1	85,1	85,1	35
4228	34,71	81,6	81,6	81,6	35	34,71	81,6	81,6	81,6	35	44,91	84,4	84,4	84,4	35	41,00	90,7	90,7	90,7	35	41,00	90,7	90,7	90,7	35

ED / EU.V																									
VERSION C					VERSION C + ELECTRICAL HEATERS					VERSION C + ELECTRICAL HEATERS + DEHUMIDIFICATION					VERSION D					VERSION D + ELECTRICAL HEATERS					
kW	L1	L2	L3	mm ²	kW	L1	L2	L3	mm ²	kW	L1	L2	L3	mm ²	kW	L1	L2	L3	mm ²	kW	L1	L2	L3	mm ²	
1105	8,06	16,3	16,3	16,3	4	8,06	16,3	16,3	16,3	4	14,06	25,0	25,0	25,0	6	11,99	22,0	22,0	22,0	4	14,06	25,0	25,0	25,0	6
1106	8,97	20,1	20,1	20,1	4	8,97	20,1	20,1	20,1	4	14,97	28,8	28,8	28,8	6	12,90	25,8	25,8	25,8	4	14,97	28,8	28,8	28,8	6
2107	9,24	20,8	20,8	20,8	4	9,24	20,8	20,8	20,8	4	18,24	33,8	33,8	33,8	10	15,53	29,9	29,9	29,9	6	18,24	33,8	33,8	33,8	10
2207	9,24	20,8	20,8	20,8	4	9,24	20,8	20,8	20,8	4	14,98	26,2	26,2	26,2	6	15,53	29,9	29,9	29,9	6	15,53	29,9	29,9	29,9	6
2109	11,40	26,2	26,2	26,2	6	11,40	26,2	26,2	26,2	6	20,40	39,2	39,2	39,2	10	17,69	35,3	35,3	35,3	10	20,40	39,2	39,2	39,2	10
2209	11,40	26,2	26,2	26,2	6	11,40	26,2	26,2	26,2	6	16,06	28,9	28,9	28,9	6	17,69	35,3	35,3	35,3	10	17,69	35,3	35,3	35,3	10
2111	16,28	35,0	35,0	35,0	10	16,28	35,0	35,0	35,0	10	31,28	56,7	56,7	56,7	16	22,57	44,1	44,1	44,1	10	31,28	56,7	56,7	56,7	16
2211	16,28	35,0	35,0	35,0	10	16,28	35,0	35,0	35,0	10	26,11	44,8	44,8	44,8	10	22,57	44,1	44,1	44,1	10	26,11	44,8	44,8	44,8	10
2113	18,12	42,5	42,5	42,5	10	18,12	42,5	42,5	42,5	10	33,12	64,2	64,2	64,2	25	24,41	51,6	51,6	51,6	16	33,12	64,2	64,2	64,2	25
2213	18,12	42,5	42,5	42,5	10	18,12	42,5	42,5	42,5	10	27,03	48,5	48,5	48,5	16	24,41	51,6	51,6	51,6	16	24,41	51,6	51,6	51,6	16
2216	20,76	46,7	46,7	46,7	16	20,76	46,7	46,7	46,7	16	28,09	50,6	50,6	50,6	16	27,05	55,8	55,8	55,8	16	27,05	55,8	55,8	55,8	16
2218	22,68	51,3	51,3	51,3	16	22,68	51,3	51,3	51,3	16	29,05	52,9	52,9	52,9	16	28,97	60,4	60,4	60,4	16	28,97	60,4	60,4	60,4	16
2222	29,00	59,4	59,4	59,4	16	29,00	59,4	59,4	59,4	16	37,15	63,2	63,2	63,2	25	35,29	68,5	68,5	68,5	25	35,29	68,5	68,5	68,5	25
4222	32,10	62,6	62,6	62,6	25	32,10	62,6	62,6	62,6	25	38,70	64,8	64,8	64,8	25	38,39	71,7	71,7	71,7	25	38,39	71,7	71,7	71,7	25
2225	33,50	65,2	65,2	65,2	25	33,50	65,2	65,2	65,2	25	39,40	66,1	66,1	66,1	25	39,79	74,3	74,3	74,3	25	39,79	74,3	74,3	74,3	25
4225	35,70	73,0	73,0	73,0	25	35,70	73,0	73,0	73,0	25	35,70	73,0	73,0	73,0	25	41,99	82,1	82,1	82,1	35	41,99	82,1	82,1	82,1	35
4228	37,20	78,6	78,6	78,6	25	37,20	78,6	78,6	78,6	25	47,40	81,4	81,4	81,4	25	43,49	87,7	87,7	87,7	35	43,49	87,7	87,7	87,7	35

(*): **Electrical heaters - Standard**
kW kW: Nominal absorbed power
L1-L2-L3 A: Maximum current (FLA) per phase
mm² mm²: Supply wiring section (1)(2)

(1) Recommended. Select the correct power supply cable depending on the characteristics of the units, the application and the installation. The characteristics of the power supply cable must take into account the maximum current absorption of the whole unit to avoid a voltage drop.

(2) **Warning:** the power supply cable must include the neutral (4x...+...PE) for chilled water units with optional condensate drain pump and fan booster for fresh air.

It is recommended to use back-up protection upstream of the power supply cable for trip current ICC up to 10 kA.

**Electrical heaters
High capacity**

ED / EU.B																									
VERSION C					VERSION C + ELECTRICAL HEATERS					VERSION C + ELECTRICAL HEATERS + DEHUMIDIFICATION					VERSION D					VERSION D + ELECTRICAL HEATERS					
kW	L1	L2	L3	mm ²	kW	L1	L2	L3	mm ²	kW	L1	L2	L3	mm ²	kW	L1	L2	L3	mm ²	kW	L1	L2	L3	mm ²	
1105	6,22	16,7	11,9	11,9	4	10,05	17,8	13,0	13,0	4	15,22	29,7	24,9	24,9	6	10,15	22,4	16,7	16,7	4	15,22	29,7	24,9	24,9	6
1106	7,13	20,5	15,7	15,7	4	7,13	20,5	15,7	15,7	4	16,13	33,5	28,7	28,7	10	11,06	26,2	20,5	20,5	6	16,13	33,5	28,7	28,7	10
2107	9,35	20,5	20,5	20,5	4	17,83	27,0	27,0	27,0	6	24,35	42,2	42,2	42,2	10	15,64	29,6	29,6	29,6	6	24,35	42,2	42,2	42,2	10
2207	9,35	20,5	20,5	20,5	4	17,83	27,0	27,0	27,0	6	21,09	34,6	34,6	34,6	10	15,64	29,6	29,6	29,6	6	24,12	36,0	36,0	36,0	10
2109	11,51	25,9	25,9	25,9	6	17,83	27,0	27,0	27,0	6	26,51	47,6	47,6	47,6	16	17,80	35,0	35,0	35,0	10	26,51	47,6	47,6	47,6	16
2209	11,51	25,9	25,9	25,9	6	17,83	27,0	27,0	27,0	6	22,17	37,3	37,3	37,3	10	17,80	35,0	35,0	35,0	10	22,17	37,3	37,3	37,3	10
2111	15,89	34,4	34,4	34,4	10	23,55	36,6	36,6	36,6	10	33,89	60,4	60,4	60,4	16	22,18	43,5	43,5	43,5	10	33,89	60,4	60,4	60,4	16
2211	15,89	34,4	34,4	34,4	10	23,55	36,6	36,6	36,6	10	28,72	48,5	48,5	48,5	16	22,18	43,5	43,5	43,5	10	28,72	48,5	48,5	48,5	16
2113	17,73	41,9	41,9	41,9	10	17,73	41,9	41,9	41,9	10	35,73	67,9	67,9	67,9	25	24,02	51,0	51,0	51,0	16	35,73	67,9	67,9	67,9	25
2213	17,73	41,9	41,9	41,9	10	17,73	41,9	41,9	41,9	10	29,64	52,2	52,2	52,2	16	24,02	51,0	51,0	51,0	16	29,64	52,2	52,2	52,2	16
2216	21,00	46,1	46,1	46,1	10	21,00	46,1	46,1	46,1	10	31,33	54,4	54,4	54,4	16	27,29	55,2	55,2	55,2	16	27,29	52,2	52,2	52,2	16
2218	22,92	50,7	50,7	50,7	16	22,92	50,7	50,7	50,7	16	32,29	56,7	56,7	56,7	16	29,21	59,8	59,8	59,8	16	29,21	59,8	59,8	59,8	16
2222	26,78	62,4	62,4	62,4	25	26,78	62,4	62,4	62,4	25	40,93	74,9	74,9	74,9	25	33,07	71,5	71,5	71,5	25	40,93	74,9	74,9	74,9	25
4222	29,88	65,6	65,6	65,6	25	29,88	65,6	65,6	65,6	25	42,48	76,4	76,4	76,4	25	36,17	74,7	74,7	74,7	25	42,48	76,4	76,4	76,4	25
2225	31,28	68,2	68,2	68,2	25	31,28	68,2	68,2	68,2	25	43,18	77,7	77,7	77,7	25	37,57	77,3	77,3	77,3	25	43,18	77,7	77,7	77,7	25
4225	33,48	76,0	76,0	76,0	25	33,48	76,0	76,0	76,0	25	44,28	81,6	81,6	81,6	35	39,77	85,1	85,1	85,1	35	39,77	85,1	85,1	85,1	35
4228	34,71	81,6	81,6	81,6	35	34,71	81,6	81,6	81,6	35	47,91	88,8	88,8	88,8	35	41,00	90,7	90,7	90,7	35	41,00	90,7	90,7	90,7	35

ED / EU.V																									
VERSION C					VERSION C + ELECTRICAL HEATERS					VERSION C + ELECTRICAL HEATERS + DEHUMIDIFICATION					VERSION D					VERSION D + ELECTRICAL HEATERS					
kW	L1	L2	L3	mm ²	kW	L1	L2	L3	mm ²	kW	L1	L2	L3	mm ²	kW	L1	L2	L3	mm ²	kW	L1	L2	L3	mm ²	
1105	8,06	16,3	16,3	16,3	4	11,89	17,4	17,4	17,4	4	17,06	29,3	29,3	29,3	6	11,99	22,0	22,0	22,0	4	17,06	29,3	29,3	29,3	6
1106	8,97	20,1	20,1	20,1	4	8,97	20,1	20,1	20,1	4	17,97	33,1	33,1	33,1	6	12,90	25,8	25,8	25,8	6	17,97	33,1	33,1	33,1	6
2107	9,24	20,8	20,8	20,8	4	17,72	27,3	27,3	27,3	6	24,24	42,5	42,5	42,5	10	15,53	29,9	29,9	29,9	6	24,24	42,5	42,5	42,5	10
2207	9,24	20,8	20,8	20,8	4	17,72	27,3	27,3	27,3	6	20,98	34,9	34,9	34,9	10	15,53	29,9	29,9	29,9	6	24,01	36,3	36,3	36,3	10
2109	11,40	26,2	26,2	26,2	6	17,72	27,3	27,3	27,3	6	26,40	47,9	47,9	47,9	16	17,69	35,3	35,3	35,3	10	26,40	47,9	47,9	47,9	16
2209	11,40	26,2	26,2	26,2	6	17,72	27,3	27,3	27,3	6	22,06	37,6	37,6	37,6	10	17,69	35,3	35,3	35,3	10	22,06	37,6	37,6	37,6	10
2111	16,28	35,0	35,0	35,0	10	23,94	37,2	37,2	37,2	10	34,28	61,0	61,0	61,0	16	22,57	44,1	44,1	44,1	10	34,28	61,0	61,0	61,0	16
2211	16,28	35,0	35,0	35,0	10	23,94	37,2	37,2	37,2	10	29,11	49,1	49,1	49,1	16	22,57	44,1	44,1	44,1	10	29,11	49,1	49,1	49,1	16
2113	18,12	42,5	42,5	42,5	10	18,12	42,5	42,5	42,5	10	36,12	68,5	68,5	68,5	25	24,41	51,6	51,6	51,6	16	36,12	68,5	68,5	68,5	25
2213	18,12	42,5	42,5	42,5	10	18,12	42,5	42,5	42,5	10	30,03	52,8	52,8	52,8	16	24,41	51,6	51,6	51,6	16	30,03	52,8	52,8	52,8	16
2216	20,76	46,7	46,7	46,7	16	20,76	46,7	46,7	46,7	16	31,09	55,0	55,0	55,0	16	27,05	55,8	55,8	55,8	16	27,05	55,8	55,8	55,8	16
2218	22,68	51,3	51,3	51,3	16	22,68	51,3	51,3	51,3	16	32,05	57,3	57,3	57,3	16	28,97	60,4	60,4	60,4	16	28,97	60,4	60,4	60,4	16
2222	29,00	59,4	59,4	59,4	16	29,00	59,4	59,4	59,4	16	43,15	71,9	71,9	71,9	25	35,29	68,5	68,5	68,5	25	43,15	71,9	71,9	71,9	25
4222	32,10	62,6	62,6	62,6	25	32,10	62,6	62,6	62,6	25	44,70	73,4	73,4	73,4	25	38,39	71,7	71,7	71,7	25	44,70	73,4	73,4	73,4	25
2225	33,50	65,2	65,2	65,2	25	33,50	65,2	65,2	65,2	25	45,40	74,7	74,7	74,7	25	39,79	74,3	74,3	74,3	25	45,40	74,7	74,7	74,7	25
4225	35,70	73,0	73,0	73,0	25	35,70	73,0	73,0	73,0	25	46,50	78,6	78,6	78,6	25	41,99	82,1	82,1	82,1	35	41,99	82,1	82,1	82,1	35
4228	37,20	78,6	78,6	78,6	25	37,20	78,6	78,6	78,6	25	50,40	85,8	85,8	85,8	35	43,49	87,7	87,7	87,7	35	43,49	87,7	87,7	87,7	35

(**): **Electrical heaters
High capacity**
 kW kW: Nominal absorbed power
 L1-L2-L3 A: Maximum current (FLA) per phase
 mm² mm²: Supply wiring section (1)(2)

(1) Recommended. Select the correct power supply cable depending on the characteristics of the units, the application and the installation. The characteristics of the power supply cable must take into account the maximum current absorption of the whole unit to avoid a voltage drop.

(2) **Warning:** the power supply cable must include the neutral (4x...+...PE) for chilled water units with optional condensate drain pump and fan booster for fresh air.

Compressors (R410A)

ED / EU.B-V						
No	VOLT	kW (1)	OA (1)	FLA (1)	LRA (1)	
1105	1	400 / 3 / 50	5,2	8,9	11,9	66,0
1106	1	400 / 3 / 50	6,1	10,5	15,7	73,0
2107	2	400 / 3 / 50	3,3	6,1	7,6	48,0
2207	2	400 / 3 / 50	3,3	6,1	7,6	48,0
2109	2	400 / 3 / 50	4,3	7,5	10,3	63,0
2209	2	400 / 3 / 50	4,3	7,5	10,3	63,0
2111	2	400 / 3 / 50	5,2	8,9	11,9	66,0
2211	2	400 / 3 / 50	5,2	8,9	11,9	66,0
2113	2	400 / 3 / 50	6,1	10,5	15,7	73,0
2213	2	400 / 3 / 50	6,1	10,5	15,7	73,0
2216	2	400 / 3 / 50	7,7	14,1	17,8	130,0
2218	2	400 / 3 / 50	8,6	15,9	20,1	130,0
2222	2	400 / 3 / 50	9,9	18,2	22,2	100,0
4222	4	400 / 3 / 50	5,7	9,6	11,9	66,7
2225	2	400 / 3 / 50	12,1	20,6	25,1	158,0
4225	4	400 / 3 / 50	6,6	11,3	14,5	73,0
4228	4	400 / 3 / 50	6,9	13,2	15,9	100,0

No Number of compressor
 VOLT [V/ph/Hz] Supply voltage
 kW [kW] Absorbed power (1)
 OA [A] Operating current (1)
 FLA [A] Full load current (1)
 LRA [A] Locked rotor current (1)
 (1) For each compressor

Fans

ED / EU.B									(1) (2) Data refers to	
No	VOLT	kW (1) (3)	OA (1) (3)	kW (2) (3)	OA (2) (3)	FLA (3)	LRA (3)			
1105	1	230 / 1 / 50	0,8	3,9	1,1	4,8	4,8	12,0	@ 20 Pa 5740 m³/h - 167 V	@ 217 Pa 5740 m³/h - 230 V
1106	1	230 / 1 / 50	0,8	3,9	1,1	4,8	4,8	12,0	@ 20 Pa 5740 m³/h - 167 V	@ 217 Pa 5740 m³/h - 230 V
2107	1	400 / 3 / 50	1,8	5,0	2,8	4,8	5,3	15,0	@ 20 Pa 8180 m³/h - 250 V	@ 409 Pa 8180 m³/h - 400 V
2207	1	400 / 3 / 50	1,8	5,0	2,8	4,8	5,3	15,0	@ 20 Pa 8180 m³/h - 250 V	@ 409 Pa 8180 m³/h - 400 V
2109	1	400 / 3 / 50	1,8	5,0	2,8	4,8	5,3	15,0	@ 20 Pa 8180 m³/h - 250 V	@ 409 Pa 8180 m³/h - 400 V
2209	1	400 / 3 / 50	1,8	5,0	2,8	4,8	5,3	15,0	@ 20 Pa 8180 m³/h - 250 V	@ 409 Pa 8180 m³/h - 400 V
2111	2	400 / 3 / 50	1,8	5,1	2,8	4,6	5,3	15,0	@ 20 Pa 11710 m³/h - 250 V	@ 480 Pa 11710 m³/h - 400 V
2211	2	400 / 3 / 50	1,8	5,1	2,8	4,6	5,3	15,0	@ 20 Pa 11710 m³/h - 250 V	@ 480 Pa 11710 m³/h - 400 V
2113	2	400 / 3 / 50	1,8	5,1	2,8	4,6	5,3	15,0	@ 20 Pa 11710 m³/h - 250 V	@ 480 Pa 11710 m³/h - 400 V
2211	2	400 / 3 / 50	1,8	5,1	2,8	4,6	5,3	15,0	@ 20 Pa 11710 m³/h - 250 V	@ 480 Pa 11710 m³/h - 400 V
2216	2	400 / 3 / 50	1,8	5,0	2,8	4,8	5,3	15,0	@ 20 Pa 15600 m³/h - 250 V	@ 452 Pa 15600 m³/h - 400 V
2218	2	400 / 3 / 50	1,8	5,0	2,8	4,8	5,3	15,0	@ 20 Pa 15600 m³/h - 250 V	@ 452 Pa 15600 m³/h - 400 V
2222	3	400 / 3 / 50	1,5	4,7	2,4	4,5	6,0	18,0	@ 20 Pa 22075 m³/h - 230 V	@ 330 Pa 22075 m³/h - 400 V
4222	3	400 / 3 / 50	1,5	4,7	2,4	4,5	6,0	18,0	@ 20 Pa 22075 m³/h - 230 V	@ 330 Pa 22075 m³/h - 400 V
2225	3	400 / 3 / 50	1,6	4,6	2,4	4,5	6,0	18,0	@ 20 Pa 23132 m³/h - 240 V	@ 290 Pa 23132 m³/h - 400 V
4225	3	400 / 3 / 50	1,6	4,6	2,4	4,5	6,0	18,0	@ 20 Pa 23132 m³/h - 240 V	@ 290 Pa 23132 m³/h - 400 V
4228	3	400 / 3 / 50	1,7	4,6	2,4	4,5	6,0	18,0	@ 20 Pa 23500 m³/h - 260 V	@ 240 Pa 23500 m³/h - 400 V

No Fan motors number
 VOLT [V/ph/Hz] Supply voltage
 kW [kW] Absorbed power (3)
 OA [A] Operating current (3)
 FLA [A] Full load current (3)
 LRA [A] Locked Rotor Current (3)
 (3) each motor

Fans

ED / EU.V									(1) (2) Data refers to	
No	VOLT	kW (1) (3)	OA (1) (3)	kW (2) (3)	OA (2) (3)	FLA (3)	LRA (3)			
1105	1	400 / 3 / 50	0,7	1,2	2,9	4,4	4,4	-	@ 20 Pa 5740 m³/h - 58%	@ 701 Pa 5740 m³/h - 100%
1106	1	400 / 3 / 50	0,7	1,2	2,9	4,4	4,4	-	@ 20 Pa 5740 m³/h - 58%	@ 701 Pa 5740 m³/h - 100%
2107	1	400 / 3 / 50	0,8	1,3	2,7	4,7	5,6	-	@ 20 Pa 8220 m³/h - 68%	@ 668 Pa 8220 m³/h - 100%
2207	1	400 / 3 / 50	0,8	1,3	2,7	4,7	5,6	-	@ 20 Pa 8220 m³/h - 68%	@ 668 Pa 8220 m³/h - 100%
2109	1	400 / 3 / 50	0,8	1,3	2,7	4,7	5,6	-	@ 20 Pa 8220 m³/h - 68%	@ 668 Pa 8220 m³/h - 100%
2209	1	400 / 3 / 50	0,8	1,3	2,7	4,7	5,6	-	@ 20 Pa 8220 m³/h - 68%	@ 668 Pa 8220 m³/h - 100%
2111	2	400 / 3 / 50	0,8	1,3	3,0	5,3	5,6	-	@ 20 Pa 12320 m³/h - 61%	@ 712 Pa 12320 m³/h - 100%
2211	2	400 / 3 / 50	0,8	1,3	3,0	5,3	5,6	-	@ 20 Pa 12320 m³/h - 61%	@ 712 Pa 12320 m³/h - 100%
2113	2	400 / 3 / 50	0,8	1,3	3,0	5,3	5,6	-	@ 20 Pa 12320 m³/h - 61%	@ 712 Pa 12320 m³/h - 100%
2213	2	400 / 3 / 50	0,8	1,3	3,0	5,3	5,6	-	@ 20 Pa 12320 m³/h - 61%	@ 712 Pa 12320 m³/h - 100%
2216	2	400 / 3 / 50	0,9	1,4	2,7	4,7	5,6	-	@ 20 Pa 16030 m³/h - 70%	@ 628 Pa 16030 m³/h - 100%
2218	2	400 / 3 / 50	0,9	1,4	2,7	4,7	5,6	-	@ 20 Pa 16030 m³/h - 70%	@ 628 Pa 16030 m³/h - 100%
2222	3	400 / 3 / 50	1,0	1,6	2,9	4,9	5,0	-	@ 20 Pa 22712 m³/h - 68%	@ 550 Pa 22712 m³/h - 100%
4222	3	400 / 3 / 50	1,0	1,6	2,9	4,9	5,0	-	@ 20 Pa 22712 m³/h - 68%	@ 550 Pa 22712 m³/h - 100%
2225	3	400 / 3 / 50	1,1	1,8	2,7	4,3	5,0	-	@ 20 Pa 24272 m³/h - 71%	@ 450 Pa 24272 m³/h - 100%
4225	3	400 / 3 / 50	1,1	1,8	2,7	4,3	5,0	-	@ 20 Pa 24272 m³/h - 71%	@ 450 Pa 24272 m³/h - 100%
4228	3	400 / 3 / 50	1,3	2,0	2,7	4,4	5,0	-	@ 20 Pa 25294 m³/h - 74%	@ 410 Pa 25294 m³/h - 100%

No Fan motors number
 VOLT [V/ph/Hz] Supply voltage
 kW [kW] Absorbed power (3)
 OA [A] Operating current (3)
 FLA [A] Full load current (3)
 LRA [A] Locked Rotor Current (3)
 (3) each motor

Electrical Heaters

ED / EU.B-V								
Standard capacity				High capacity				
VOLT	No	kW	OA	VOLT	No	kW	OA	
1105	400 / 3 / 50	2	6,0	8,7	400 / 3 / 50	3	9,0	13,0
1106	400 / 3 / 50	2	6,0	8,7	400 / 3 / 50	3	9,0	13,0
2107	400 / 3 / 50	3	9,0	13,0	400 / 3 / 50	5	15,0	21,7
2207	400 / 3 / 50	3	9,0	13,0	400 / 3 / 50	5	15,0	21,7
2109	400 / 3 / 50	3	9,0	13,0	400 / 3 / 50	5	15,0	21,7
2209	400 / 3 / 50	3	9,0	13,0	400 / 3 / 50	5	15,0	21,7
2111	400 / 3 / 50	5	15,0	21,7	400 / 3 / 50	6	18,0	26,0
2211	400 / 3 / 50	5	15,0	21,7	400 / 3 / 50	6	18,0	26,0
2113	400 / 3 / 50	5	15,0	21,7	400 / 3 / 50	6	18,0	26,0
2213	400 / 3 / 50	5	15,0	21,7	400 / 3 / 50	6	18,0	26,0
2213	400 / 3 / 50	5	15,0	21,7	400 / 3 / 50	6	18,0	26,0
2218	400 / 3 / 50	5	15,0	21,7	400 / 3 / 50	6	18,0	26,0
2222	400 / 3 / 50	6	18,0	26,0	400 / 3 / 50	8	24,0	34,7
4222	400 / 3 / 50	6	18,0	26,0	400 / 3 / 50	8	24,0	34,7
2225	400 / 3 / 50	6	18,0	26,0	400 / 3 / 50	8	24,0	34,7
4225	400 / 3 / 50	6	18,0	26,0	400 / 3 / 50	8	24,0	34,7
4228	400 / 3 / 50	6	24,0	37,7	400 / 3 / 50	9	27,0	39,0

No Number of element
 VOLT [V/ph/Hz] Supply voltage
 kW [kW] Total nominal absorbed power
 OA [A] Total operating current

Humidifier

ED / EU.B-V				
	VOLT	No	kW	OA
1105	400 / 3 / 50	1	3,93	5,7
1106	400 / 3 / 50	1	3,93	5,7
2107	400 / 3 / 50	1	6,3	9,1
2207	400 / 3 / 50	1	6,3	9,1
2109	400 / 3 / 50	1	6,3	9,1
2209	400 / 3 / 50	1	6,3	9,1
2111	400 / 3 / 50	1	6,3	9,1
2211	400 / 3 / 50	1	6,3	9,1
2113	400 / 3 / 50	1	6,3	9,1
2213	400 / 3 / 50	1	6,3	9,1
2216	400 / 3 / 50	1	6,3	9,1
2218	400 / 3 / 50	1	6,3	9,1
2222	400 / 3 / 50	1	6,3	9,1
4222	400 / 3 / 50	1	6,3	9,1
2225	400 / 3 / 50	1	6,3	9,1
4225	400 / 3 / 50	1	6,3	9,1
4228	400 / 3 / 50	1	6,3	9,1

No Number of humidifier
VOLT [V/ph/Hz] Supply voltage
kW [kW] Nominal absorbed power
OA [A] Operating current

Electrical heaters - Standard

ED / EU.B																				
VERSION C					VERSION C + ELECTRICAL HEATERS					VERSION D					VERSION D + ELECTRICAL HEATERS					
kW	L1	L2	L3	mm ²	kW	L1	L2	L3	mm ²	kW	L1	L2	L3	mm ²	kW	L1	L2	L3	mm ²	
0070	0,98	5,0	-	-	2,5	6,98	13,7	8,7	8,7	2,5	4,91	10,7	5,7	5,7	2,5	10,91	19,3	14,3	14,3	4
0100	2,79	5,3	5,3	5,3	2,5	11,79	18,3	18,3	18,3	4	9,08	14,4	14,4	14,4	2,5	18,08	27,4	27,4	27,4	6
0120	2,78	5,3	5,3	5,3	2,5	11,78	18,3	18,3	18,3	4	9,07	14,4	14,4	14,4	2,5	18,07	27,4	27,4	27,4	6
0170	5,64	10,6	10,6	10,6	2,5	20,64	32,3	32,3	32,3	6	11,93	19,7	19,7	19,7	4	26,93	41,3	41,3	41,3	10
0200	5,63	10,6	10,6	10,6	2,5	20,63	32,3	32,3	32,3	6	11,92	19,7	19,7	19,7	4	26,92	41,3	41,3	41,3	10
0250	5,63	10,6	10,6	10,6	2,5	20,63	32,3	32,3	32,3	6	11,92	19,7	19,7	19,7	4	26,92	41,3	41,3	41,3	10
0270	6,20	12,0	12,0	12,0	2,5	21,20	33,7	33,7	33,7	10	12,49	21,1	21,1	21,1	4	27,49	42,7	42,7	42,7	10
0340	7,29	18,0	18,0	18,0	4	31,29	52,6	52,6	52,6	16	19,09	35,0	35,0	35,0	10	43,09	69,7	69,7	69,7	25
0400	7,29	18,0	18,0	18,0	4	31,29	52,6	52,6	52,6	16	19,09	35,0	35,0	35,0	10	43,09	69,7	69,7	69,7	25

ED / EU.V																				
VERSION C					VERSION C + ELECTRICAL HEATERS					VERSION D					VERSION D + ELECTRICAL HEATERS					
kW	L1	L2	L3	mm ²	kW	L1	L2	L3	mm ²	kW	L1	L2	L3	mm ²	kW	L1	L2	L3	mm ²	
0070	2,88	4,4	4,4	4,4	2,5	8,88	13,1	13,1	13,1	2,5	6,81	10,1	10,1	10,1	2,5	12,81	18,7	18,7	18,7	4
0100	2,73	5,6	5,6	5,6	2,5	11,73	18,6	18,6	18,6	4	9,02	14,7	14,7	14,7	4	18,02	27,7	27,7	27,7	6
0120	2,72	5,6	5,6	5,6	2,5	11,72	18,6	18,6	18,6	4	9,01	14,7	14,7	14,7	4	18,01	27,7	27,7	27,7	6
0170	6,28	11,2	11,2	11,2	2,5	21,28	32,9	32,9	32,9	6	12,57	20,3	20,3	20,3	4	27,57	41,9	41,9	41,9	10
0200	5,48	11,2	11,2	11,2	2,5	20,48	32,9	32,9	32,9	6	11,77	20,3	20,3	20,3	4	26,77	41,9	41,9	41,9	10
0250	5,48	11,2	11,2	11,2	2,5	20,48	32,9	32,9	32,9	6	11,77	20,3	20,3	20,3	4	26,77	41,9	41,9	41,9	10
0270	6,14	10,0	10,0	10,0	2,5	21,14	31,7	31,7	31,7	6	12,43	19,1	19,1	19,1	4	27,43	40,7	40,7	40,7	10
0340	9,12	15,0	15,0	15,0	4	33,12	49,6	49,6	49,6	16	20,92	32,0	32,0	32,0	6	44,92	66,7	66,7	66,7	25
0400	9,12	15,0	15,0	15,0	4	33,12	49,6	49,6	49,6	16	20,92	32,0	32,0	32,0	6	44,92	66,7	66,7	66,7	25

(*): **Electrical heaters - Standard**
 kW kW: Nominal absorbed power
 L1-L2-L3 A: Maximum current (FLA) per phase
 mm² mm²: Supply wiring section (1)(2)

(1) Recommended. Select the correct power supply cable depending on the characteristics of the units, the application and the installation. The characteristics of the power supply cable must take into account the maximum current absorption of the whole unit to avoid a voltage drop.

(2) **Warning:** the power supply cable must include the neutral (4x...+...PE) for chilled water units with optional condensate drain pump and fan booster for fresh air.

It is recommended to use back-up protection upstream of the power supply cable for trip current ICC up to 10 kA.

Electrical heaters

High capacity

ED / EU.B																				
VERSION C					VERSION C + ELECTRICAL HEATERS					VERSION D					VERSION D + ELECTRICAL HEATERS					
kW	L1	L2	L3	mm ²	kW	L1	L2	L3	mm ²	kW	L1	L2	L3	mm ²	kW	L1	L2	L3	mm ²	
0070	0,98	5,0	-	-	2,5	9,98	18,0	13,0	13,0	4	4,91	10,7	5,7	5,7	2,5	13,91	23,7	18,7	18,7	6
0100	2,79	5,3	5,3	5,3	2,5	17,9	27,0	27,0	27,0	6	9,08	14,4	14,4	14,4	2,5	24,08	36,0	36,0	36,0	10
0120	2,78	5,3	5,3	5,3	2,5	17,78	27,0	27,0	27,0	6	9,07	14,4	14,4	14,4	2,5	24,07	36,0	36,0	36,0	10
0170	5,64	10,6	10,6	10,6	2,5	23,64	36,6	36,6	36,6	10	11,93	19,7	19,7	19,7	4	29,93	45,7	45,7	45,7	10
0200	5,63	10,6	10,6	10,6	2,5	23,63	36,6	36,6	36,6	10	11,92	19,7	19,7	19,7	4	29,92	45,7	45,7	45,7	10
0250	5,63	10,6	10,6	10,6	2,5	23,63	36,6	36,6	36,6	10	11,92	19,7	19,7	19,7	4	29,92	45,7	45,7	45,7	10
0270	6,20	12,0	12,0	12,0	2,5	24,20	38,0	38,0	38,0	10	12,49	21,1	21,1	21,1	4	30,49	47,1	47,1	47,1	16
0340	7,29	18,0	18,0	18,0	4	34,29	57,0	57,0	57,0	16	19,09	35,0	35,0	35,0	10	46,09	74,0	74,0	74,0	25
0400	7,29	18,0	18,0	18,0	4	34,29	57,0	57,0	57,0	16	19,09	35,0	35,0	35,0	10	46,09	74,0	74,0	74,0	25

ED / EU.V																				
VERSION C					VERSION C + ELECTRICAL HEATERS					VERSION D					VERSION D + ELECTRICAL HEATERS					
kW	L1	L2	L3	mm ²	kW	L1	L2	L3	mm ²	kW	L1	L2	L3	mm ²	kW	L1	L2	L3	mm ²	
0070	2,88	4,4	4,4	4,4	2,5	11,8	17,4	17,4	17,4	4	6,81	10,1	10,1	10,1	2,5	15,81	23,1	23,1	23,1	4
0100	2,73	5,6	5,6	5,6	2,5	17,73	27,3	27,3	27,3	6	9,02	14,7	14,7	14,7	4	24,02	36,3	36,3	36,3	10
0120	2,72	5,6	5,6	5,6	2,5	17,72	27,3	27,3	27,3	6	9,01	14,7	14,7	14,7	4	24,01	36,3	36,3	36,3	10
0170	6,28	11,2	11,2	11,2	2,5	24,28	37,2	37,2	37,2	10	12,57	20,3	20,3	20,3	4	30,57	43,6	43,6	43,6	10
0200	5,48	11,2	11,2	11,2	2,5	23,48	37,2	37,2	37,2	10	11,77	20,3	20,3	20,3	4	29,77	43,6	43,6	43,6	10
0250	5,48	11,2	11,2	11,2	2,5	23,48	37,2	37,2	37,2	10	11,77	20,3	20,3	20,3	4	29,77	43,6	43,6	43,6	10
0270	6,14	10,0	10,0	10,0	2,5	24,14	36,0	36,0	36,0	10	12,43	19,1	19,1	19,1	4	30,43	45,1	45,1	45,1	10
0340	9,12	15,0	15,0	15,0	4	36,12	54,0	54,0	54,0	16	20,92	32,0	32,0	32,0	6	47,92	71,0	71,0	71,0	25
0400	9,12	15,0	15,0	15,0	4	36,12	54,0	54,0	54,0	16	20,92	32,0	32,0	32,0	6	47,92	71,0	71,0	71,0	25

(*): **Electrical heaters - Standard**
 kW kW: Nominal absorbed power
 L1-L2-L3 A: Maximum current (FLA) per phase
 mm² mm²: Supply wiring section (1)(2)

(1) Recommended. Select the correct power supply cable depending on the characteristics of the units, the application and the installation. The characteristics of the power supply cable must take into account the maximum current absorption of the whole unit to avoid a voltage drop.

(2) **Warning:** the power supply cable must include the neutral (4x...+...PE) for chilled water units with optional condensate drain pump and fan booster for fresh air.

It is recommended to use back-up protection upstream of the power supply cable for trip current ICC up to 10 kA.

Fans

ED / EU.B									(1) (2) Data refers to	
No	VOLT	kW (1) (3)	OA (1) (3)	kW (2) (3)	OA (2) (3)	FLA (3)	LRA (3)			
0070	1	230 / 1 / 50	0,9	4,2	0,8	4,5	5,0	12,0	@ 20 Pa 6060 m³/h - 195 V	@ 20 Pa 6610 m³/h - 230 V
0100	1	400 / 3 / 50	2,4	5,1	2,7	4,6	5,3	15,0	@ 20 Pa 10140 m³/h - 320 V	@ 20 Pa 11360 m³/h - 400 V
0120	1	400 / 3 / 50	2,5	5,1	2,7	4,6	5,3	15,0	@ 20 Pa 10470 m³/h - 340 V	@ 20 Pa 11340 m³/h - 400 V
0170	2	400 / 3 / 50	1,9	5,1	2,8	4,7	5,3	15,0	@ 20 Pa 14570 m³/h - 260 V	@ 20 Pa 20540 m³/h - 400 V
0200	2	400 / 3 / 50	2,3	5,2	2,8	4,7	5,3	15,0	@ 20 Pa 18780 m³/h - 310 V	@ 20 Pa 21550 m³/h - 400 V
0250	2	400 / 3 / 50	2,4	5,2	2,8	4,7	5,3	15,0	@ 20 Pa 18760 m³/h - 320 V	@ 20 Pa 21220 m³/h - 400 V
0270	1	400 / 3 / 50	2,8	5,7	3,0	5,1	6,0	15,0	@ 20 Pa 18725 m³/h - 340 V	@ 20 Pa 20644 m³/h - 400 V
0340	1	400 / 3 / 50	1,8	4,5	2,4	4,4	6,0	18,0	@ 20 Pa 24778 m³/h - 280 V	@ 20 Pa 28527 m³/h - 400 V
0400	1	400 / 3 / 50	2,0	4,5	2,4	4,4	6,0	18,0	@ 20 Pa 25200 m³/h - 300 V	@ 20 Pa 28092 m³/h - 400 V

No Fan motors number
 VOLT [V/ph/Hz] Supply voltage
 kW [kW] Absorbed power (3)
 OA [A] Operating current (3)
 FLA [A] Full load current (3)
 LRA [A] Locked Rotor Current (3)
 (3) each motor

Fans

ED / EU.V									(1) (2) Data refers to	
No	VOLT	kW (1) (3)	OA (1) (3)	kW (2) (3)	OA (2) (3)	FLA (3)	LRA (3)			
0070	1	400 / 3 / 50	0,8	1,3	2,6	4,0	4,4	-	@ 20 Pa 6060 m³/h - 61%	@ 20 Pa 9620 m³/h - 100%
0100	1	400 / 3 / 50	1,4	2,1	2,6	4,2	5,6	-	@ 20 Pa 10000 m³/h - 81%	@ 20 Pa 12050 m³/h - 100%
0120	1	400 / 3 / 50	1,4	2,1	2,6	4,2	5,6	-	@ 20 Pa 10000 m³/h - 82%	@ 20 Pa 12040 m³/h - 100%
0170	2	400 / 3 / 50	0,9	1,5	2,7	4,4	5,6	-	@ 20 Pa 14000 m³/h - 65%	@ 20 Pa 21930 m³/h - 100%
0200	2	400 / 3 / 50	1,4	2,1	2,6	4,4	5,6	-	@ 20 Pa 18680 m³/h - 80%	@ 20 Pa 22990 m³/h - 100%
0250	2	400 / 3 / 50	1,5	2,3	2,6	4,4	5,6	-	@ 20 Pa 18880 m³/h - 82%	@ 20 Pa 22670 m³/h - 100%
0270	1	400 / 3 / 50	1,7	2,6	3,0	4,9	5,0	-	@ 20 Pa 18761 m³/h - 82%	@ 20 Pa 22417 m³/h - 100%
0340	1	400 / 3 / 50	1,4	2,2	3,0	4,9	5,0	-	@ 20 Pa 24875 m³/h - 77%	@ 20 Pa 32255 m³/h - 100%
0400	1	400 / 3 / 50	1,5	2,4	3,0	5,0	5,0	-	@ 20 Pa 25218 m³/h - 79%	@ 20 Pa 31950 m³/h - 100%

No Fan motors number
 VOLT [V/ph/Hz] Supply voltage
 kW [kW] Absorbed power (3)
 OA [A] Operating current (3)
 FLA [A] Full load current (3)
 LRA [A] Locked Rotor Current (3)
 (3) each motor

Electrical Heaters

ED / EU.B-V								
Capacità standard - Standard capacity - Puissance Standard				Capacità maggiorata - High capacity - Puissance augmentée				
VOLT	No	kW	OA	VOLT	No	kW	OA	
0070	400 / 3 / 50	2	6,0	8,7	400 / 3 / 50	3	9,0	13,0
0100	400 / 3 / 50	3	9,0	13,0	400 / 3 / 50	5	15,0	21,7
0120	400 / 3 / 50	3	9,0	13,0	400 / 3 / 50	5	15,0	21,7
0170	400 / 3 / 50	5	15,0	21,7	400 / 3 / 50	6	18,0	26,0
0200	400 / 3 / 50	5	15,0	21,7	400 / 3 / 50	6	18,0	26,0
0250	400 / 3 / 50	5	15,0	21,7	400 / 3 / 50	6	18,0	26,0
0270	400 / 3 / 50	5	15,0	21,7	400 / 3 / 50	6	18,0	26,0
0340	400 / 3 / 50	8	24,0	34,7	400 / 3 / 50	9	27,0	39,0
0400	400 / 3 / 50	8	24,0	34,7	400 / 3 / 50	9	27,0	39,0

No Number of element
 VOLT [V/ph/Hz] Supply voltage
 kW [kW] Total nominal absorbed power
 OA [A] Total operating current

Humidifier

ED / EU.B-V				
VOLT	No	kW	OA	
0070	400 / 3 / 50	1	3,93	5,7
0100	400 / 3 / 50	1	6,3	9,1
0120	400 / 3 / 50	1	6,3	9,1
0170	400 / 3 / 50	1	6,3	9,1
0200	400 / 3 / 50	1	6,3	9,1
0250	400 / 3 / 50	1	6,3	9,1
0270	400 / 3 / 50	1	6,3	9,1
0340	400 / 3 / 50	1	11,8	17,0
0400	400 / 3 / 50	1	11,8	17,0

No Number of humidifier
 VOLT [V/ph/Hz] Supply voltage
 kW [kW] Nominal absorbed power
 OA [A] Operating current

Upflow units

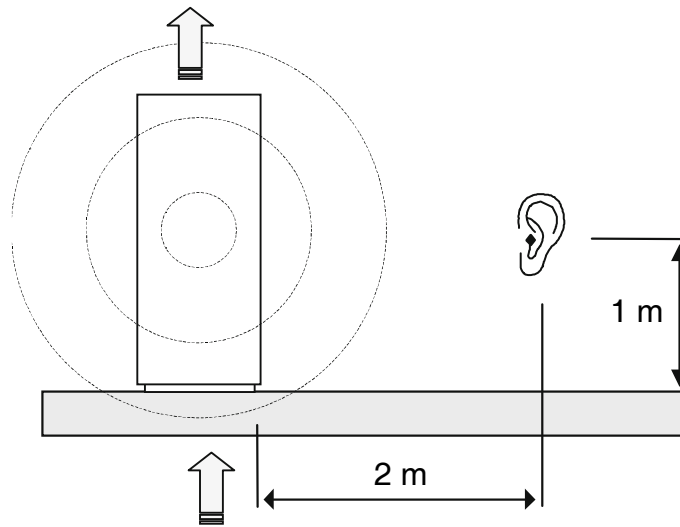

Measurements taken at 1 mt. above the floor and at a distance of 2 mt. from the front of the room unit running at nominal working conditions, with front air discharge.

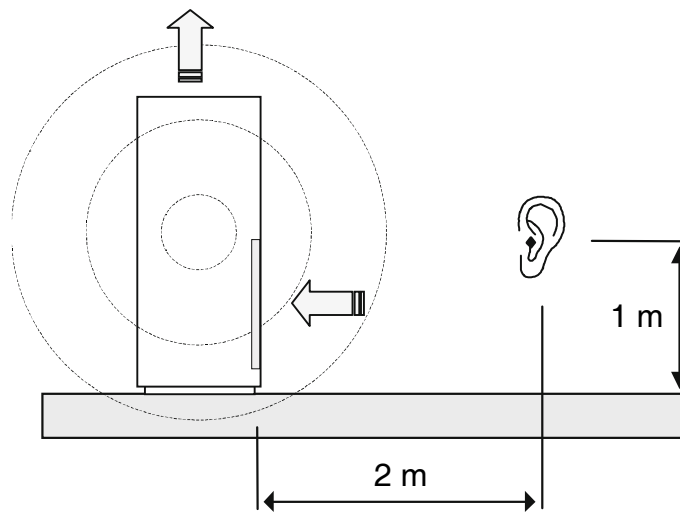

Measurements taken at 1 mt. above the floor and at a distance of 2 mt. from the front of the room unit running at nominal working conditions.

Noise pressure levels, measured with a BRUEL & KIAER mod. 2235 phonometer - according to IEC 651 standard, class II - fitted with octave filter mod. 1625, refer to free field conditions, without the effect of ambient reverberation. The A-weighted noise level, given in dB(A), is measured according to ISO R 226-1987 standard.

Downflow units

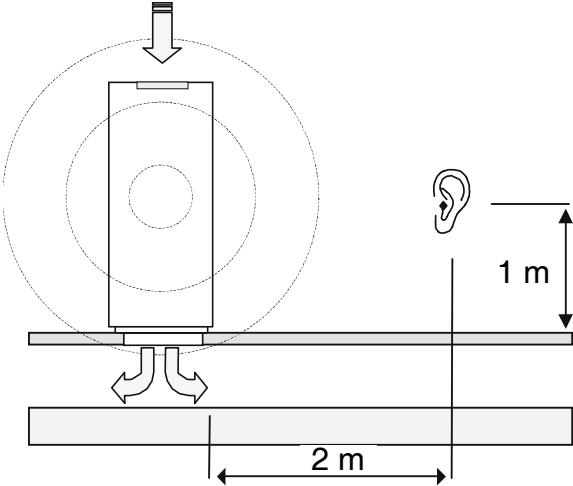

Measurements taken at 1 metre above the floor and at a distance of 2 metres from the front of the room unit placed on a raised floor 300 mm high and running at nominal working conditions without the effect of grilles and holes in the raised floor.

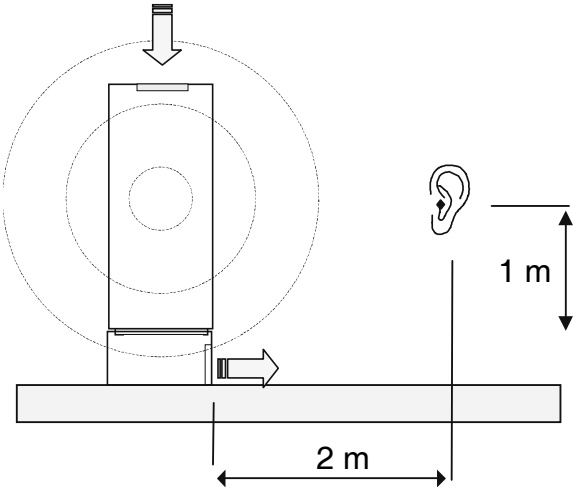

Measurements taken at 1 mt. above the floor and at a distance of 2 mt. from the front of the room unit with front discharge plenum.

The noise pressure levels, measured with a BRUEL & KIAER mod. 2235 phonometer - according to IEC 651 standard, class II - fitted with octave filter mod. 1625, refer to free field conditions, without the effect of ambient reverberation.
The A-weighted noise level, given in dB(A), is measured according to ISO R 226-1987 standard.

Chilled water units

Upflow units

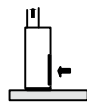
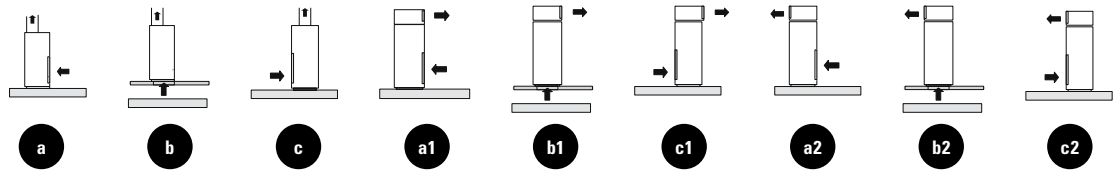

ANALYSIS IN Hz LINEAR FREQUENCY								dB(A)
63	125	250	500	1 k	2 k	4 k		

EUCB0070	V NOM 6060 m³/h @ 20 Pa	66,2	76,0	64,3	54,5	50,2	40,9	36,0	59,2
	V MAX 6600 m³/h @ 20 Pa	66,1	75,9	64,2	54,4	50,1	40,8	35,9	62,0
EUCB0100	V NOM 10200 m³/h @ 20 Pa	65,5	75,3	63,6	53,8	49,5	40,2	35,3	61,4
	V MAX 11440 m³/h @ 20 Pa	70,1	79,9	68,2	58,4	54,1	44,8	39,9	66,0
EUCB0120	V NOM 10420 m³/h @ 20 Pa	66,4	76,2	64,5	54,7	50,4	41,1	36,2	62,3
	V MAX 11340 m³/h @ 20 Pa	69,6	79,4	67,7	57,9	53,6	44,3	39,4	65,5
EUCB0170	V NOM 14920 m³/h @ 20 Pa	64,4	74,2	62,5	52,7	48,4	39,1	34,2	60,3
	V MAX 20540 m³/h @ 20 Pa	70,6	80,4	68,7	58,9	54,6	45,3	40,4	66,5
EUCB0200	V NOM 18680 m³/h @ 20 Pa	63,6	73,4	61,7	51,9	47,6	38,3	33,4	64,7
	V MAX 21550 m³/h @ 20 Pa	70,5	80,3	68,6	58,8	54,5	45,2	40,3	66,4
EUCB0250	V NOM 18680 m³/h @ 20 Pa	64,7	74,5	62,8	53,0	48,7	39,4	34,5	65,8
	V MAX 21220 m³/h @ 20 Pa	70,7	80,5	68,8	59,0	54,7	45,4	40,5	66,6

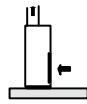

ANALYSIS IN Hz LINEAR FREQUENCY								dB(A)
63	125	250	500	1 k	2 k	4 k		

EUCV0070	V NOM 5990 m³/h @ 20 Pa	28,0	47,7	43,0	39,0	38,0	29,8	24,8	49,8
EUCV0100	V NOM 10000 m³/h @ 20 Pa	62,5	72,3	60,6	50,8	46,5	37,2	32,3	58,4
	V MAX 11830 m³/h @ 20 Pa	67,1	76,9	65,2	55,4	51,1	41,8	36,9	63,0
EUCV0120	V NOM 10000 m³/h @ 20 Pa	63,4	73,2	61,5	51,7	47,4	38,1	33,2	59,3
	V MAX 11700 m³/h @ 20 Pa	66,6	76,4	64,7	54,9	50,6	41,3	36,4	62,5
EUCV0170	V NOM 14000 m³/h @ 20 Pa	61,4	71,2	59,5	49,7	45,4	36,1	31,2	57,3
	V MAX 21330 m³/h @ 20 Pa	67,6	77,4	65,7	55,9	51,6	42,3	37,4	63,5
EUCV0200	V NOM 18680 m³/h @ 20 Pa	60,6	70,4	58,7	48,9	44,6	35,3	30,4	61,7
	V MAX 23390 m³/h @ 20 Pa	67,5	77,3	65,6	55,8	51,5	42,2	37,3	63,4
EUCV0250	V NOM 18880 m³/h @ 20 Pa	61,7	71,5	59,8	50,0	45,7	36,4	31,5	62,8
	V MAX 21350 m³/h @ 20 Pa	67,7	77,5	65,8	56,0	51,7	42,4	37,5	63,6



Leq (c) = Leq (b)

Leq (a1) ≈ Leq (a) + 6 dBa
 Leq (b1) ≈ Leq (b) + 6 dBa
 Leq (c1) ≈ Leq (b) + 6 dBa

Leq (a2) ≈ Leq (a)
 Leq (b2) ≈ Leq (b)
 Leq (c2) ≈ Leq (b)

Chilled water units

Upflow units

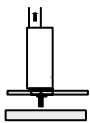
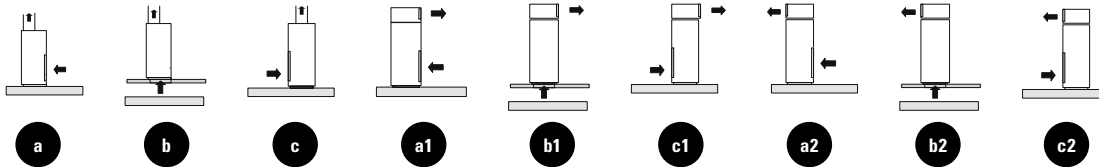

		ANALYSIS IN Hz LINEAR FREQUENCY							
		63	125	250	500	1 k	2 k	4 k	dB(A)
EUCB0070	V NOM 6060 m³/h @ 20 Pa	62,2	72,0	60,3	50,5	46,2	36,9	32,0	55,2
	V MAX 6600 m³/h @ 20 Pa	62,1	71,9	60,2	50,4	46,1	36,8	31,9	58,0
EUCB0100	V NOM 10200 m³/h @ 20 Pa	61,5	71,3	59,6	49,8	45,5	36,2	31,3	57,4
	V MAX 11440 m³/h @ 20 Pa	66,1	75,9	64,2	54,4	50,1	40,8	35,9	62,0
EUCB0120	V NOM 10420 m³/h @ 20 Pa	62,4	72,2	60,5	50,7	46,4	37,1	32,2	58,3
	V MAX 11340 m³/h @ 20 Pa	65,6	75,4	63,7	53,9	49,6	40,3	35,4	61,5
EUCB0170	V NOM 14920 m³/h @ 20 Pa	60,4	70,2	58,5	48,7	44,4	35,1	30,2	56,3
	V MAX 20540 m³/h @ 20 Pa	66,6	76,4	64,7	54,9	50,6	41,3	36,4	62,5
EUCB0200	V NOM 18680 m³/h @ 20 Pa	59,6	69,4	57,7	47,9	43,6	34,3	19,4	60,7
	V MAX 21550 m³/h @ 20 Pa	66,5	76,3	64,6	54,8	50,5	41,2	36,3	62,4
EUCB0250	V NOM 18680 m³/h @ 20 Pa	60,7	70,5	58,8	49,0	44,7	35,4	30,5	61,8
	V MAX 21220 m³/h @ 20 Pa	66,7	76,5	64,8	55,0	50,7	41,5	36,5	62,6

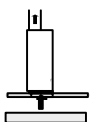

		ANALYSIS IN Hz LINEAR FREQUENCY							
		63	125	250	500	1 k	2 k	4 k	dB(A)
EUCV0070	V NOM 5990 m³/h @ 20 Pa	24,7	44,8	40,0	36,0	35,0	26,8	21,8	46,8
EUCV0100	V NOM 10000 m³/h @ 20 Pa	59,5	69,3	57,6	47,8	43,5	34,2	29,3	55,4
	V MAX 11830 m³/h @ 20 Pa	64,1	73,9	62,2	52,4	48,1	38,8	33,9	60,0
EUCV0120	V NOM 10000 m³/h @ 20 Pa	60,4	70,2	58,5	48,7	44,4	35,1	30,2	56,3
	V MAX 11700 m³/h @ 20 Pa	63,6	73,4	61,7	51,9	47,6	38,3	33,4	59,5
EUCV0170	V NOM 14000 m³/h @ 20 Pa	58,4	68,2	56,5	46,7	42,4	33,1	28,2	54,3
	V MAX 21330 m³/h @ 20 Pa	64,6	74,4	62,7	52,9	48,6	39,9	34,4	60,5
EUCV0200	V NOM 18680 m³/h @ 20 Pa	57,6	67,4	55,7	45,9	41,6	32,3	27,4	58,7
	V MAX 23390 m³/h @ 20 Pa	64,5	74,3	62,6	52,8	48,5	39,2	34,3	60,4
EUCV0250	V NOM 18880 m³/h @ 20 Pa	58,7	68,5	56,8	47,0	42,7	33,4	28,5	59,8
	V MAX 21350 m³/h @ 20 Pa	64,7	74,5	62,8	53,0	48,7	39,4	34,5	60,6



Leq (c) = Leq (b)

Leq (a1) ≈ Leq (a) + 6 dBa
 Leq (b1) ≈ Leq (b) + 6 dBa
 Leq (c1) ≈ Leq (b) + 6 dBa

Leq (a2) ≈ Leq (a)
 Leq (b2) ≈ Leq (b)
 Leq (c2) ≈ Leq (b)

Chilled water units

Downflow units

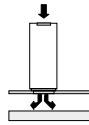
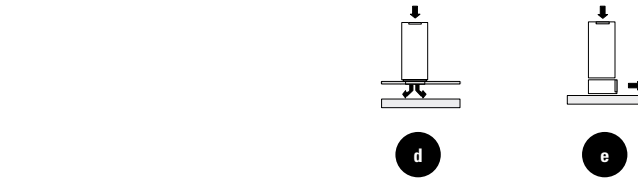

		ANALYSIS IN Hz LINEAR FREQUENCY							
		63	125	250	500	1 k	2 k	4 k	dB(A)
EDCB0070	V NOM 6060 m³/h @ 20 Pa	61,2	71,0	59,3	49,5	45,2	35,9	31,0	54,2
	V MAX 6600 m³/h @ 20 Pa	61,1	70,9	59,2	49,4	45,1	35,8	30,9	57,0
EDCB0100	V NOM 10200 m³/h @ 20 Pa	60,5	70,3	58,6	48,8	44,5	35,2	30,3	56,4
	V MAX 11440 m³/h @ 20 Pa	65,1	74,9	63,2	53,4	49,1	39,8	34,9	61,0
EDCB0120	V NOM 10420 m³/h @ 20 Pa	61,4	71,2	59,5	49,7	45,4	36,1	31,2	57,3
	V MAX 11340 m³/h @ 20 Pa	64,6	74,4	62,7	52,9	48,6	39,3	34,4	60,5
EDCB0170	V NOM 14920 m³/h @ 20 Pa	59,4	69,2	57,5	47,7	43,4	34,1	29,2	55,3
	V MAX 20540 m³/h @ 20 Pa	65,6	75,4	63,7	53,9	49,6	40,3	35,4	61,5
EDCB0200	V NOM 18680 m³/h @ 20 Pa	58,6	68,4	56,7	46,9	42,6	33,3	28,4	59,7
	V MAX 21550 m³/h @ 20 Pa	65,5	75,3	63,6	53,8	49,5	40,2	35,3	61,4
EDCB0250	V NOM 18680 m³/h @ 20 Pa	59,7	69,5	57,8	48,0	43,7	34,4	29,5	60,8
	V MAX 21220 m³/h @ 20 Pa	65,7	75,5	63,8	54,0	49,7	40,4	35,5	61,6
EDCB0270	V NOM 18725 m³/h @ 20Pa	59,0	74,4	63,3	53,9	47,4	44,9	36,7	61,4
	V MAX 20644 m³/h @ 20Pa	61,5	76,9	65,8	56,4	49,9	47,4	39,2	63,9
EDCB0340	V NOM 24778 m³/h @ 20Pa	56,5	71,9	60,8	51,4	44,9	42,4	34,2	58,9
	V MAX 28527 m³/h @ 20Pa	61,5	76,9	65,8	56,4	49,9	47,4	39,2	63,9
EDCB0400	V NOM 25200 m³/h @ 20Pa	57,2	72,6	61,5	52,1	45,6	43,1	34,9	59,6
	V MAX 28092 m³/h @ 20Pa	61,3	76,7	65,6	56,2	49,7	47,2	39,0	63,7

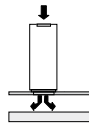

		ANALYSIS IN Hz LINEAR FREQUENCY							
		63	125	250	500	1 k	2 k	4 k	dB(A)
EDCV0070	V NOM 5990 m³/h @ 20 Pa	24,7	44,8	40,0	36,0	35,0	26,8	21,8	46,8
EDCV0100	V NOM 10000 m³/h @ 20 Pa	59,5	69,3	57,6	47,8	43,5	34,2	29,3	55,4
	V MAX 11830 m³/h @ 20 Pa	64,1	73,9	62,2	52,4	48,1	38,8	33,9	60,0
EDCV0120	V NOM 10000 m³/h @ 20 Pa	60,4	70,2	58,5	48,7	44,4	35,1	30,2	56,3
	V MAX 11700 m³/h @ 20 Pa	63,6	73,4	61,7	51,9	47,6	38,3	33,4	59,5
EDCV0170	V NOM 14000 m³/h @ 20 Pa	58,4	68,2	56,5	46,7	42,4	33,1	28,2	54,3
	V MAX 21330 m³/h @ 20 Pa	64,6	74,4	62,7	52,9	48,6	39,3	34,4	60,5
EDCV0200	V NOM 18680 m³/h @ 20 Pa	57,6	67,4	55,7	45,9	41,6	32,3	27,4	58,7
	V MAX 23390 m³/h @ 20 Pa	64,5	74,3	62,6	52,8	48,5	39,2	34,3	60,4
EDCV0250	V NOM 18880 m³/h @ 20 Pa	58,7	68,5	56,8	47,0	42,7	33,4	28,5	59,8
	V MAX 21350 m³/h @ 20 Pa	64,7	74,5	62,8	53,0	48,7	39,4	34,5	60,6
EDCV0270	V NOM 18761 m³/h @ 20Pa	66,8	77	60,2	51,6	45,9	41,8	38,8	61,9
	V MAX 22417 m³/h @ 20Pa	74,8	84	65,5	57	51	46,4	50	68,7
EDCV0340	V NOM 24875 m³/h @ 20Pa	66,8	75,9	60,2	51,6	45,9	41,8	38,8	61
	V MAX 32255 m³/h @ 20Pa	75,1	85,0	69,5	60,6	54,0	49,0	45,0	70,0
EDCV0400	V NOM 25218 m³/h @ 20Pa	67	76,9	60,5	51,6	45,9	41,8	38,8	61,8
	V MAX 31950 m³/h @ 20Pa	75,1	85,0	69,5	60,6	54,0	49,0	45,0	70,0

Leq (c) = Leq (b)

Leq (a1) ≈ Leq (a) + 6 dBa
 Leq (b1) ≈ Leq (b) + 6 dBa
 Leq (c1) ≈ Leq (b) + 6 dBa

Leq (a2) ≈ Leq (a)
 Leq (b2) ≈ Leq (b)
 Leq (c2) ≈ Leq (b)

Direct expansion models

Upflow units

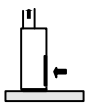
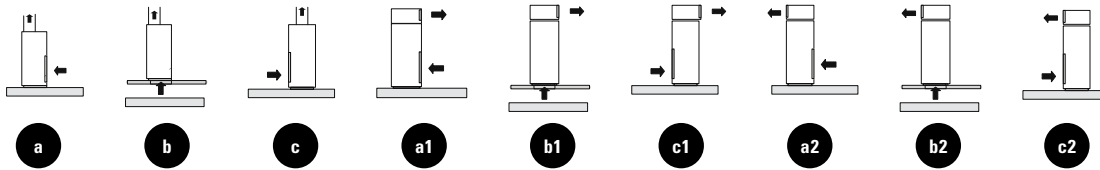

		ANALYSIS IN Hz LINEAR FREQUENCY							
		63	125	250	500	1 k	2 k	4 k	dB(A)
EU*B1105	V _{NOM} 5740 m³/h @ 20 Pa	58,1	67,9	56,2	46,4	42,1	32,8	27,9	54,0
EU*B1106	V _{NOM} 5740 m³/h @ 20 Pa	58,1	67,9	56,2	46,4	42,1	32,8	27,9	54,0
EU*B2107	V _{NOM} 8180 m³/h @ 20 Pa	67,4	67,4	60,2	50,9	46,9	40,9	34,3	56,2
EU*B2207	V _{NOM} 8180 m³/h @ 20 Pa	67,4	67,4	60,2	50,9	46,9	40,9	34,3	56,2
EU*B2109	V _{NOM} 8180 m³/h @ 20 Pa	67,4	67,4	60,2	50,9	46,9	40,9	34,3	56,2
EU*B2209	V _{NOM} 11710 m³/h @ 20 Pa	66,1	71,7	60,2	53,1	45,1	40,0	33,3	58,2
EU*B2111	V _{NOM} 11710 m³/h @ 20 Pa	66,1	71,7	60,2	53,1	45,1	40,0	33,3	58,2
EU*B2211	V _{NOM} 11710 m³/h @ 20 Pa	66,1	71,7	60,2	53,1	45,1	40,0	33,3	58,2
EU*B2113	V _{NOM} 11710 m³/h @ 20 Pa	66,1	71,7	60,2	53,1	45,1	40,0	33,3	58,2
EU*B2213	V _{NOM} 15600 m³/h @ 20 Pa	67,6	73,2	61,7	54,6	46,6	41,5	34,8	59,7
EU*B2216	V _{NOM} 15600 m³/h @ 20 Pa	67,6	73,2	61,7	54,6	46,6	41,5	34,8	59,7
EU*B2218	V _{NOM} 15600 m³/h @ 20 Pa	67,6	73,2	61,7	54,6	46,6	41,5	34,8	59,7

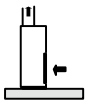

		ANALYSIS IN Hz LINEAR FREQUENCY							
		63	125	250	500	1 k	2 k	4 k	dB(A)
EU*V1105	V _{NOM} 5740 m³/h @ 20 Pa	27,7	47,5	42,8	39,0	37,7	29,4	24,5	49,6
EU*V1106	V _{NOM} 5740 m³/h @ 20 Pa	27,7	47,5	42,8	39,0	37,7	29,4	24,5	49,6
EU*V2107	V _{NOM} 8220 m³/h @ 20 Pa	71,4	71,4	64,2	54,9	50,9	44,9	38,3	60,2
EU*V2207	V _{NOM} 8220 m³/h @ 20 Pa	71,4	71,4	64,2	54,9	50,9	44,9	38,3	60,2
EU*V2109	V _{NOM} 8220 m³/h @ 20 Pa	71,4	71,4	64,2	54,9	50,9	44,9	38,3	60,2
EU*V2209	V _{NOM} 12230 m³/h @ 20 Pa	70,1	75,7	64,2	57,1	49,1	44,0	37,3	62,2
EU*V2111	V _{NOM} 12230 m³/h @ 20 Pa	70,1	75,7	64,2	57,1	49,1	44,0	37,3	62,2
EU*V2211	V _{NOM} 12230 m³/h @ 20 Pa	70,1	75,7	64,2	57,1	49,1	44,0	37,3	62,2
EU*V2113	V _{NOM} 12230 m³/h @ 20 Pa	70,1	75,7	64,2	57,1	49,1	44,0	37,3	62,2
EU*V2213	V _{NOM} 16030 m³/h @ 20 Pa	73,6	76,2	67,7	60,6	52,6	47,5	40,8	65,7
EU*V2216	V _{NOM} 16030 m³/h @ 20 Pa	73,6	76,2	67,7	60,6	52,6	47,5	40,8	65,7
EU*V2218	V _{NOM} 16030 m³/h @ 20 Pa	73,6	76,2	67,7	60,6	52,6	47,5	40,8	65,7



Leq (c) = Leq (b)

Leq (a1) ≈ Leq (a) + 6 dBa
 Leq (b1) ≈ Leq (b) + 6 dBa
 Leq (c1) ≈ Leq (b) + 6 dBa

Leq (a2) ≈ Leq (a)
 Leq (b2) ≈ Leq (b)
 Leq (c2) ≈ Leq (b)

Direct expansion models

Upflow units

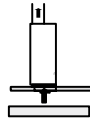
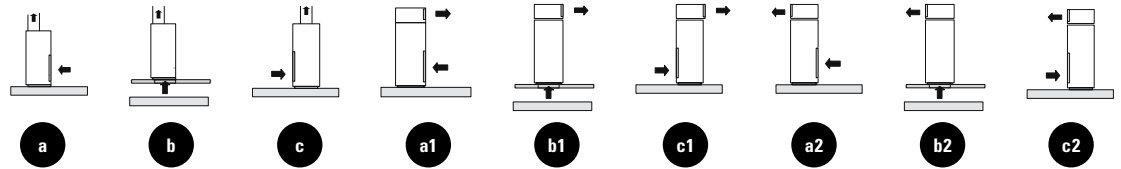

		ANALYSIS IN Hz LINEAR FREQUENCY							
		63	125	250	500	1 k	2 k	4 k	dB(A)
EU*B1105	V NOM 5740 m³/h @ 20 Pa	61,4	73,9	62,2	52,4	48,1	38,8	33,9	52,2
EU*B1106	V NOM 5740 m³/h @ 20 Pa	61,4	73,9	62,2	52,4	48,1	38,8	33,9	52,2
EU*B2107	V NOM 8180 m³/h @ 20 Pa	73,4	73,4	66,2	56,9	52,9	46,9	40,3	62,2
EU*B2207	V NOM 8180 m³/h @ 20 Pa	73,4	73,4	66,2	56,9	52,9	46,9	40,3	62,2
EU*B2109	V NOM 8180 m³/h @ 20 Pa	73,4	73,4	66,2	56,9	52,9	46,9	40,3	62,2
EU*B2209	V NOM 11710 m³/h @ 20 Pa	72,1	77,7	66,2	59,1	51,1	46,0	39,3	64,2
EU*B2111	V NOM 11710 m³/h @ 20 Pa	72,1	77,7	66,2	59,1	51,1	46,0	39,3	64,2
EU*B2211	V NOM 11710 m³/h @ 20 Pa	72,1	77,7	66,2	59,1	51,1	46,0	39,3	64,2
EU*B2113	V NOM 11710 m³/h @ 20 Pa	72,1	77,7	66,2	59,1	51,1	46,0	39,3	64,2
EU*B2213	V NOM 15600 m³/h @ 20 Pa	73,6	79,2	67,7	60,6	52,6	47,5	40,8	65,7
EU*B2216	V NOM 15600 m³/h @ 20 Pa	73,6	79,2	67,7	60,6	52,6	47,5	40,8	65,7
EU*B2218	V NOM 15600 m³/h @ 20 Pa	73,6	79,2	67,7	60,6	52,6	47,5	40,8	65,7

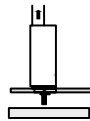

		ANALYSIS IN Hz LINEAR FREQUENCY							
		63	125	250	500	1 k	2 k	4 k	dB(A)
EU*V1105	V NOM 5740 m³/h @ 20 Pa	24,7	44,5	39,8	36,0	34,7	26,4	21,5	46,6
EU*V1106	V NOM 5740 m³/h @ 20 Pa	24,7	44,5	39,8	36,0	34,7	26,4	21,5	46,6
EU*V2107	V NOM 8220 m³/h @ 20 Pa	65,4	65,4	58,2	48,9	44,9	38,9	32,3	54,2
EU*V2207	V NOM 8220 m³/h @ 20 Pa	65,4	65,4	58,2	48,9	44,9	38,9	32,3	54,2
EU*V2109	V NOM 8220 m³/h @ 20 Pa	65,4	65,4	58,2	48,9	44,9	38,9	32,3	54,2
EU*V2209	V NOM 12230 m³/h @ 20 Pa	64,1	69,7	58,2	51,1	43,1	38,0	31,3	56,2
EU*V2111	V NOM 12230 m³/h @ 20 Pa	64,1	69,7	58,2	51,1	43,1	38,0	31,3	56,2
EU*V2211	V NOM 12230 m³/h @ 20 Pa	64,1	69,7	58,2	51,1	43,1	38,0	31,3	56,2
EU*V2113	V NOM 12230 m³/h @ 20 Pa	64,1	69,7	58,2	51,1	43,1	38,0	31,3	56,2
EU*V2213	V NOM 16030 m³/h @ 20 Pa	65,6	71,2	59,7	52,6	44,6	39,5	32,8	57,7
EU*V2216	V NOM 16030 m³/h @ 20 Pa	65,6	71,2	59,7	52,6	44,6	39,5	32,8	57,7
EU*V2218	V NOM 16030 m³/h @ 20 Pa	65,6	71,2	59,7	52,6	44,6	39,5	32,8	57,7

Leq (c) = Leq (b)

Leq (a1) ≈ Leq (a) + 6 dBa
 Leq (b1) ≈ Leq (b) + 6 dBa
 Leq (c1) ≈ Leq (b) + 6 dBa

Leq (a2) ≈ Leq (a)
 Leq (b2) ≈ Leq (b)
 Leq (c2) ≈ Leq (b)

Direct expansion models

Downflow units

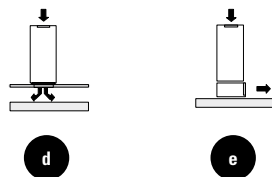
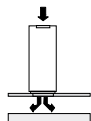

ANALYSIS IN Hz LINEAR FREQUENCY

		63	125	250	500	1 k	2 k	4 k	
									dB(A)
ED*B1105	V NOM 5740 m³/h @ 20 Pa	56,3	66,1	54,4	44,6	40,3	31,0	26,1	52,2
ED*B1106	V NOM 5740 m³/h @ 20 Pa	56,3	66,1	54,4	44,6	40,3	31,0	26,1	52,2
ED*B2107	V NOM 8180 m³/h @ 20 Pa	65,6	65,6	58,4	49,1	45,1	39,1	32,5	54,4
ED*B2207	V NOM 8180 m³/h @ 20 Pa	65,6	65,6	58,4	49,1	45,1	39,1	32,5	54,4
ED*B2109	V NOM 8180 m³/h @ 20 Pa	65,6	65,6	58,4	49,1	45,1	39,1	32,5	54,4
ED*B2209	V NOM 11710 m³/h @ 20 Pa	64,3	69,9	58,4	51,3	43,3	38,2	31,5	56,4
ED*B2111	V NOM 11710 m³/h @ 20 Pa	64,3	69,9	58,4	51,3	43,3	38,2	31,5	56,4
ED*B2211	V NOM 11710 m³/h @ 20 Pa	64,3	69,9	58,4	51,3	43,3	38,2	31,5	56,4
ED*B2113	V NOM 11710 m³/h @ 20 Pa	64,3	69,9	58,4	51,3	43,3	38,2	31,5	56,4
ED*B2213	V NOM 15600 m³/h @ 20 Pa	65,8	71,4	59,9	52,8	44,8	39,7	33,0	57,9
ED*B2216	V NOM 15600 m³/h @ 20 Pa	65,8	71,4	59,9	52,8	44,8	39,7	33,0	57,9
ED*B2218	V NOM 15600 m³/h @ 20 Pa	65,8	71,4	59,9	52,8	44,8	39,7	33,0	57,9
ED*B2222	V NOM 22000 m³/h @ 20 Pa	60,5	75,5	64,6	55,3	48,4	46,5	38,9	61,9
ED*B4222	V NOM 22000 m³/h @ 20 Pa	60,5	75,5	64,6	55,3	48,4	46,5	38,9	61,9
ED*B2225	V NOM 23000 m³/h @ 20 Pa	60,8	75,7	64,8	55,7	48,7	46,7	39,2	62,2
ED*B4225	V NOM 23000 m³/h @ 20 Pa	60,8	75,7	64,8	55,7	48,7	46,7	39,2	62,2
ED*B4228	V NOM 23500 m³/h @ 20 Pa	61,4	76,3	65,5	56,3	49,3	47,3	39,8	62,8

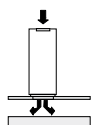

ANALYSIS IN Hz LINEAR FREQUENCY

		63	125	250	500	1 k	2 k	4 k	
									dB(A)
ED*V1105	V NOM 5740 m³/h @ 20 Pa	24,7	44,5	39,8	36,0	34,7	26,4	21,5	46,6
ED*V1106	V NOM 5740 m³/h @ 20 Pa	24,7	44,5	39,8	36,0	34,7	26,4	21,5	46,6
ED*V2107	V NOM 8220 m³/h @ 20 Pa	63,6	63,6	56,4	47,1	43,1	37,1	30,5	52,4
ED*V2207	V NOM 8220 m³/h @ 20 Pa	63,6	63,6	56,4	47,1	43,1	37,1	30,5	52,4
ED*V2109	V NOM 8220 m³/h @ 20 Pa	63,6	63,6	56,4	47,1	43,1	37,1	30,5	52,4
ED*V2209	V NOM 12230 m³/h @ 20 Pa	62,3	67,9	56,4	49,3	41,3	36,2	29,5	54,4
ED*V2111	V NOM 12230 m³/h @ 20 Pa	62,3	67,9	56,4	49,3	41,3	36,2	29,5	54,4
ED*V2211	V NOM 12230 m³/h @ 20 Pa	62,3	67,9	56,4	49,3	41,3	36,2	29,5	54,4
ED*V2113	V NOM 12230 m³/h @ 20 Pa	62,3	67,9	56,4	49,3	41,3	36,2	29,5	54,4
ED*V2213	V NOM 16030 m³/h @ 20 Pa	63,8	69,4	57,9	50,8	42,8	37,7	31,0	55,9
ED*V2216	V NOM 16030 m³/h @ 20 Pa	63,8	69,4	57,9	50,8	42,8	37,7	31,0	55,9
ED*V2218	V NOM 16030 m³/h @ 20 Pa	63,8	69,4	57,9	50,8	42,8	37,7	31,0	55,9
ED*V2222	V NOM 22000 m³/h @ 20 Pa	65,2	73,3	59,3	50,8	44,5	40,8	38,1	58,8
ED*V4222	V NOM 22000 m³/h @ 20 Pa	65,2	73,3	59,3	50,8	44,5	40,8	38,1	58,8
ED*V2225	V NOM 23000 m³/h @ 20 Pa	65,5	73,6	59,5	51,2	44,9	41,2	38,5	59,1
ED*V4225	V NOM 23000 m³/h @ 20 Pa	65,5	73,6	59,5	51,2	44,9	41,2	38,5	59,1
ED*V4228	V NOM 23500 m³/h @ 20 Pa	65,9	74,3	60,1	51,6	45,4	41,8	39,5	59,8



Leq (e) = Leq (d) + 5 dBA

EN DIMENSIONS AND WEIGHTS

ED* - EU*

1

Height adjustable
mounting frame



EU*

2

Front discharge plenum

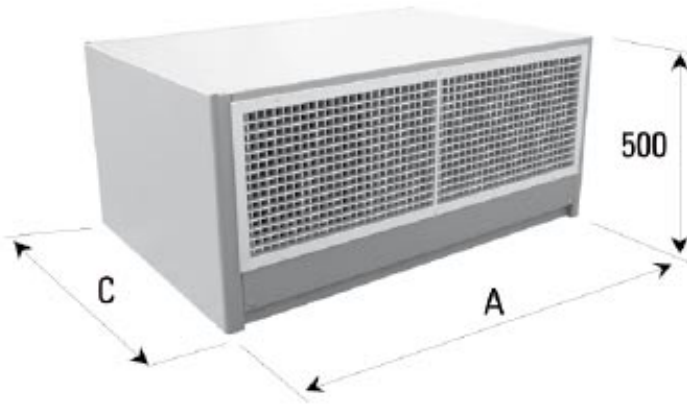

3

Discharge Plenum

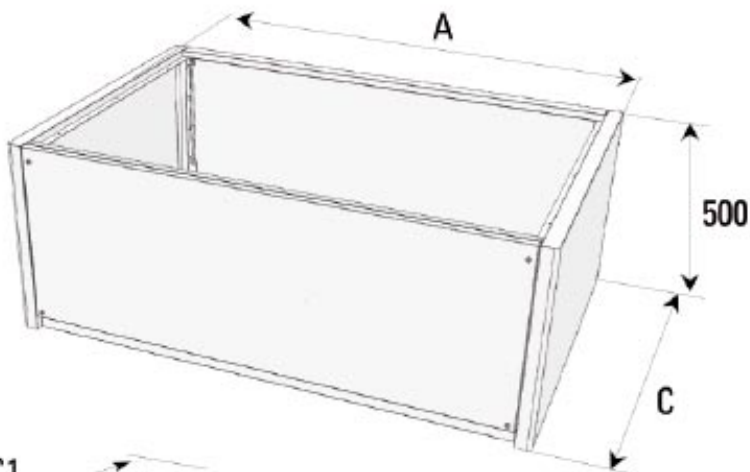

4

Enclosed floor stand for piping
(h=200 mm)



ED*

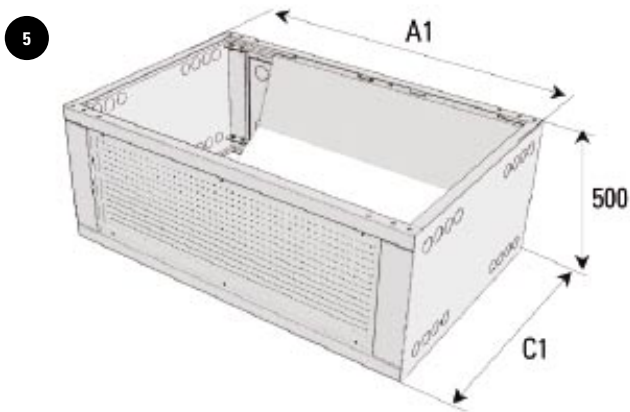

Front air discharge base module

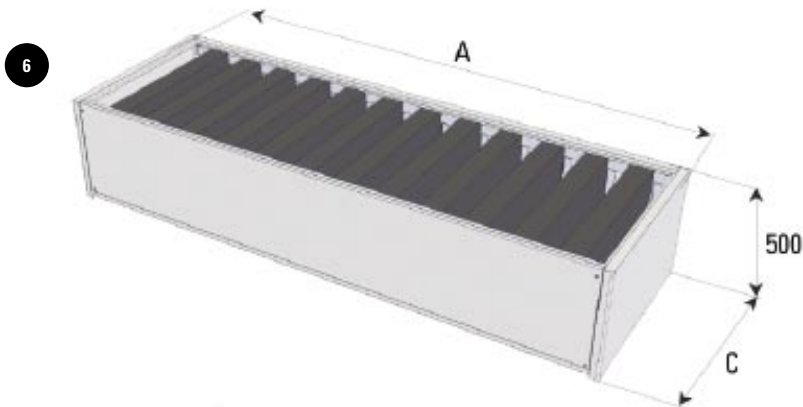

Sound Absorbing Plenum

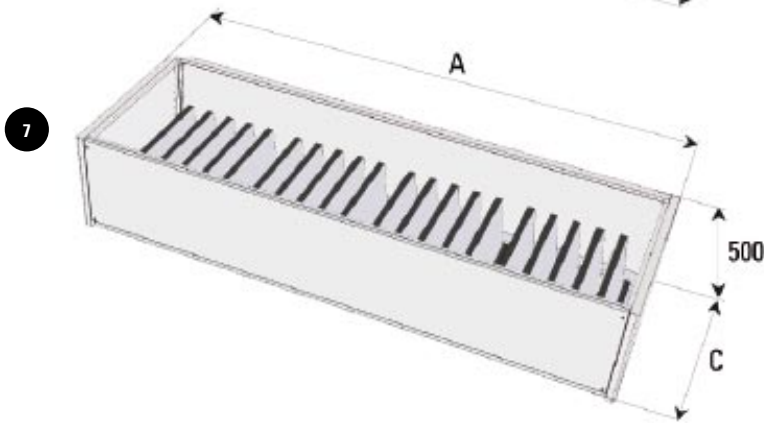

Plenum with High Efficiency Filter

	EDC* - EUC*				EDC		
	0070	0100 - 0120	0170	0200 - 0250	0270	0340	0400
A - mm	1010	1310	1720	2170	2172	2582	2562
A1 - mm	1000	1300	1710	2160	2162	2572	2572
C - mm	750	865	865	865	865	865	865
C1 - mm	740	855	855	855	855	855	855

	ED* - EU*											ED*					
	1105	1106	2107	2207	2109	2209	2111	2211	2113	2213	2216	2218	2222	4222	2225	4225	4228
A - mm	1010		1310				1720			2170			2582	2582	2582	2582	2582
A1 - mm	1000		1300				1710			2160			2572	2572	2572	2572	2572
C - mm	750		865				865			865			865	865	865	865	865
C1 - mm	740		855				855			855			855	855	855	855	855

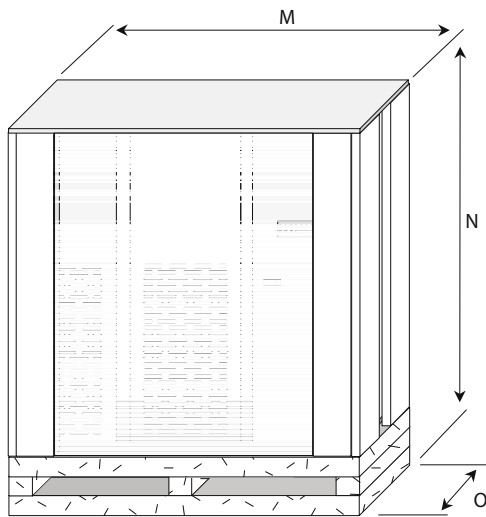
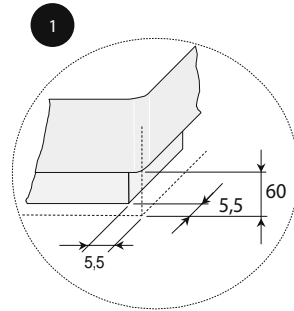
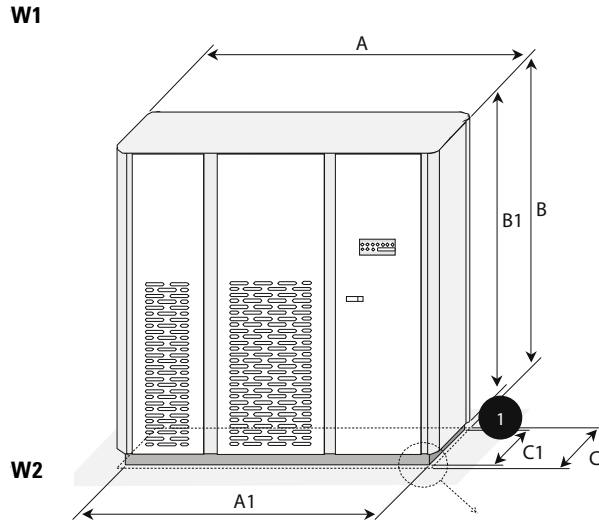

2

Unit with bottom air suction

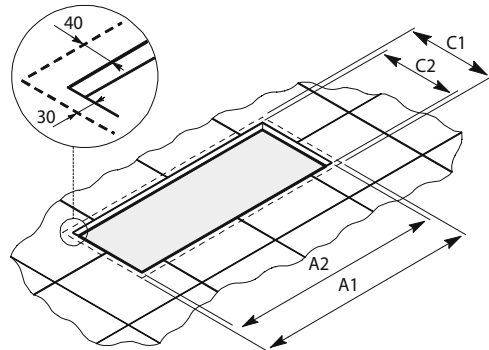

3

Unit with back air suction

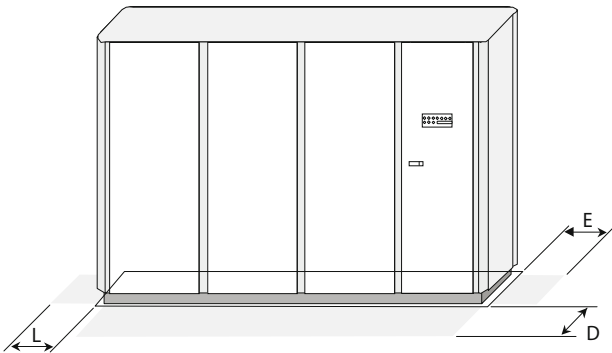
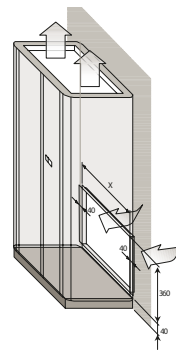

EDC - EUC							
	0070		0100 - 0120		0170	0200 - 0250	
A - mm	1010		1310		1720	2170	
A1 - mm	1000		1300		1710	2160	
A2 - mm	900		1200		1610	2060	
B - mm	1960		1960		1960	1960	
C - mm	750		865		865	865	
C1 - mm	740		855		855	855	
C2 - mm	653		769		769	769	
D - mm	800		800		800	800	
E - mm	-		-		-	-	
L - mm	-		-		-	-	
M - mm	1115		1415		1824	2275	
N - mm	2110		2110		2110	2110	
O - mm	855		855		970	970	
X - mm	890		1190		1560	2010	
W1 - kg	210	220	306	314	395	443	458
W2 - kg	230	240	344	352	425	477	492

ED*				
	0270		0340	0400
A - mm	2172		2582	2582
A1 - mm	2162		2572	2572
A2 - mm	2082		2492	2492
B - mm	1960		1960	1960
C - mm	865		865	865
C1 - mm	855		855	855
C2 - mm	775		775	775
D - mm	800		800	800
E - mm	-		-	-
L - mm	-		-	-
M - mm	2277		2687	2687
N - mm	2110		2110	2110
O - mm	970		970	970
W1 - kg	502		720	740
W2 - kg	542		785	805

W1: Weight of the heavier units (H version)

ED * - EU*

W1

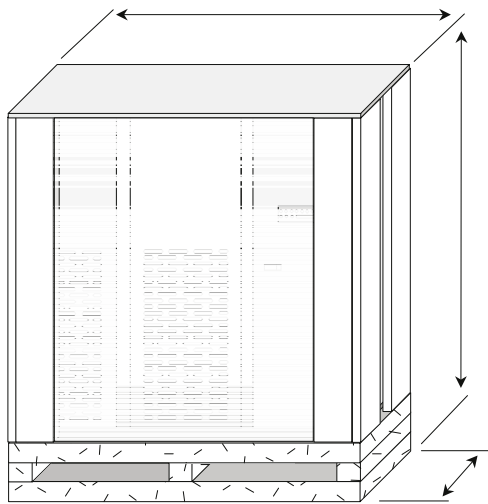
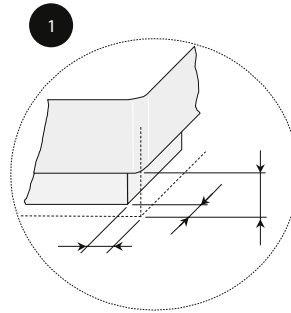
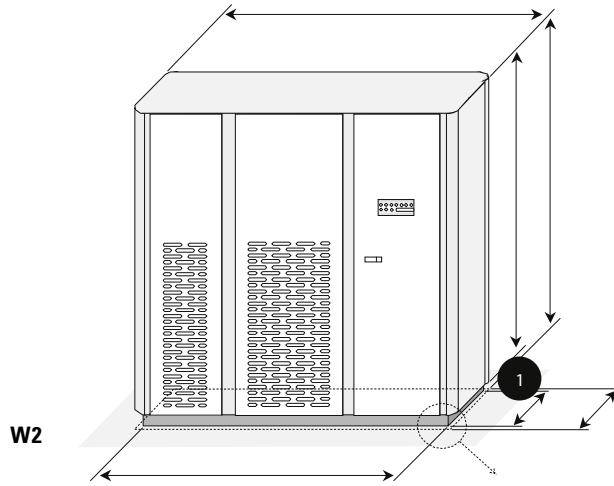

2

Unit with bottom air suction

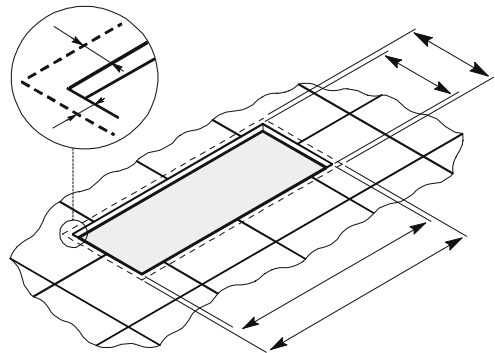

3

Unit with back air suction

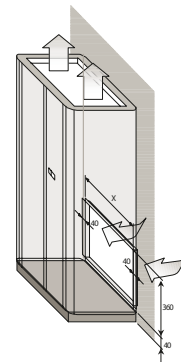

	ED*-EU*										
	1106	2107	2207	2119	2209	2111	2211	2113	2213	2216	2218
A - mm	1010		1310				1720				2170
A1 - mm	1000		1300				1710				2160
A2 - mm	900		1200				1610				2060
B - mm	1960		1960				1960				1960
C - mm	750		865				865				865
C1 - mm	740		855				855				855
C2 - mm	653		769				769				769
D - mm	800		800				800				800
E - mm	-		-				-				-
L - mm	-		-				-				-
M - mm	1115		1415				1824				2275
N - mm	2110		2110				2110				2110
O - mm	855		970				970				970
X - mm	890		1190				1560				2010
W1 - kg	310	430	447	430	447	548	559	575	585	714	714
W2 - kg	335	468	485	468	485	578	589	605	615	748	748

	ED*				
	2222	4222	2225	4225	4228
A - mm	2582	2582	2582	2582	2582
A1 - mm	2572	2572	2572	2572	2572
A2 - mm	2492	2492	2492	2492	2492
B - mm	2175	2175	2175	2175	2175
C - mm	865	865	865	865	865
C1 - mm	855	855	855	855	855
C2 - mm	406	406	406	406	406
D - mm	800	800	800	800	800
E - mm	-	-	-	-	-
L - mm	-	-	-	-	-
M - mm	2687	2687	2687	2687	2687
N - mm	2325	2325	2325	2325	2325
O - mm	970	970	970	970	970
W1 - kg	910	996	918	1020	1120
W2 - kg	975	1061	983	1085	1185

W1: Weight of the heavier units (H version)



Trane optimizes the performance of homes and buildings around the world. A business of Ingersoll Rand, the leader in creating and sustaining safe, comfortable and energy efficient environments, Trane offers a broad portfolio of advanced controls and HVAC systems, comprehensive building services, and parts. For more information, visit www.Trane.com.

Trane has a policy of continuous product and product data improvement and reserves the right to change design and specifications without notice.