



# Product catalog

One-way fan coil cassettes with AC fan motor technology - model CFAS

One-way fan coil cassettes with EC fan motor technology - model CFAE

Sizes 16-26-36



UNT-PRC017-E4



## Contents

---

<b>Introduction</b>	<b>3</b>
<b>Model number</b>	<b>5</b>
<b>Dimensions</b>	<b>6</b>
<b>General data</b>	<b>10</b>
<b>Sound spectrum</b>	<b>15</b>
<b>Water pressure drop</b>	<b>16</b>
<b>Options</b>	<b>18</b>
<b>Standalone controls</b>	<b>26</b>
<b>Group controls</b>	<b>32</b>
<b>Building Management Controls</b>	<b>36</b>
<b>Accessories</b>	<b>37</b>

# Introduction

---

## Introduction

The CFAS cassette fan coil is specifically designed for applications in office buildings from 10 to 40 m<sup>2</sup>. It is equipped with an innovative discharge and return air plenum casing capable to generate an air distribution throw with a perfect Coanda effect. The unit is a one-piece design perfectly suitable for installation in false ceilings or soffit installations.

The return air side enters into the unit vertically from the bottom through a linear grille designed to avoid seeing the filter through the openings and to maximize the air filtration efficiency which is a great progress versus conventional perforated grilles. The air diffusion goes parallel to the ceiling through an optimized number of adjustable round diffusers specifically designed to keep enough air velocity at the low speed and to avoid high velocity at higher speed.

The product is available for 2-pipe and 4-pipe applications with standard and high efficiency coils for both the cooling and the heating mode which is very beneficial to the efficiency of system working with heat pump chillers. Many factory-mounted options are available to save time during unit installation, such as electric heaters, water valves and actuators, G0 or EU3 filter, condensate water pump.

A raised version is available to increase the condensate drain outlet from 100 mm to 160 mm thus avoiding use of a condensate pump.

Several accessories are provided for field installation: water sensors, external drain pan for water valves, fresh air constant volume dampers with 100 mm and 125 mm round spigots.

There are 3 levels of control proposed, for standalone, group control and Building Management System applications. An infrared remote controller mounted on site is available for group control system for which up to 20 units can be connected together.

A wall-mounted thermostat with LCD display is also available for group control of up to 60 units.

## Main components

### Intake grille

It is made of galvanized painted steel louvers which allow 100% air opening through the filter such providing the maximum efficiency to the filter. The louvers are oriented backwards avoiding any recycling with the supply air providing also a full white appearance of the fascia for occupant's sight.

### Air supply diffusers

Made of polypropylene plastic, the innovative computer-made design  $\varnothing 170$  mm and the quantity maximize the air diffusion horizontally to the ceiling with a perfect Coanda effect that make the air to follow along the ceiling tiles and come back to the return air grille through a large room volume.

### Casing

Made of 1 mm galvanized steel with inside thermal insulation, expanded polyethylene closed cells 6 mm thickness with an outside anti-condensation lining.

### Air filter

The return air plenum is designed to maximize the filtering capability of the unit with a large filter dimension and with a return air grille considered as being 100% open which frees up the full filter face area and therefore increases the time between maintenance checks. The filtering performance is greatly improved versus a perforated grille which has only 60% opening in general. Two filtering quality options are available from factory: G0 and EU3.

### Fan assembly

Made of centrifugal fans with double suction side. The assembly is very quiet. The impellers are made of aluminum and are statically and dynamically balanced and directly mounted onto the motor shaft.



# Introduction

## EC fan motor technology

Fans represent a major part of energy consumption in air conditioning systems; the CFAE one-way cassette fan coil features an EC motor defined as a brushless direct current commutation of motor windings by means of electronic controls. It has a full load efficiency above 80% which is twice the one of a standard AC motor and thus throughout the operating range. Overall, EC motor draws an average of 4 times less in watt, providing up to 67% reduction to the annual electricity bills on the terminals.

The motor is made of a 3 phase permanent magnet motor controlled via an inverter board suitable for power supply single phase 230-240 V, 50 and 60 Hz. It is thermal protected and as a protection class B and IP20.

## AC fan motor technology

Alternatively, the CFAS one-way cassette fan coil features an AC fan motor with 6 equidistant speeds of which 3 are connected providing good flexibility to best suit the airflow needs based on the required external static pressure. It is mounted on anti-vibration supports and works with a permanent capacitor. It is protected with an internal auto reset overheat thermostat, it has an IP20 protection class and a class B insulation.

## Heat exchanger

The cooling and heating coils are made of copper tubes and aluminum fins which are bonded onto the tubes for maximum transfer contact. The water coil connections are 1/2" gas female and equipped with 1/8" vent air purge. The maximum operating pressure is 10 bar or 1000 kPa.

## Drain pan

It is made of ABS plastic with 3 mm polyethylene foam external insulation such providing no risk of corrosion. It is easily washable. For units with an electric heater, the condensate tray is made of 1 mm-thick painted galvanized steel with 3 mm of polyethylene insulation.

**Typical fan motor loads of an office building in Paris**

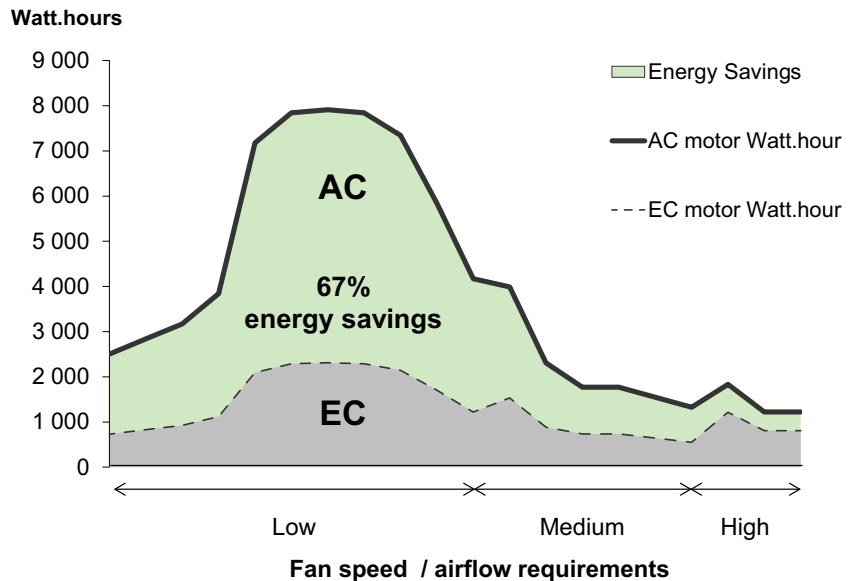

# Model number

Table 1

DIGIT		Description
1	Unit type	C = Cassette
2	Unit type	F = Fan Coil
3	Major Design Sequence	A = A
4	Motor Type	S = AC fan motor E = EC fan motor
5 + 6	Unit size	16 = 1.6 kW at speed 5 total capacity 26 = 2.6 kW at speed 5 total capacity 36 = 3.6 kW at speed 5 total capacity
7	Application	A = 2-pipe cooling only B = 2-pipe heating only (on request) C = 2-pipe changeover D = 4-pipe
8	Coil size	3 = Standard 3 rows 4 = High efficiency 4 rows 5 = High efficiency heating 3 rows plus 2 rows
9	Minor Design Sequence	B
10	Water valves and controls access sides	G = Water valves on the left, controls on the right D = Water valves on the right, controls on the left
11	Raise	X = Standard / drain outlet height 100 mm from ceiling R = Raised / drain outlet height 160 mm from ceiling
12	Filter	X = Standard G0 3 = EU3
13	Electric heater <sup>(1)</sup>	X = Without 1 = 350 W - size 16 2 = 550 W - size 16 3 = 700 W - size 26 4 = 1150 W - size 26 5 = 900 W - size 36 6 = 1400 W - size 36
14	Controls type	X = Without for wall mount thermostat interface or customer field-mounted controls A = Group control Modbus for wall-mounted thermostat or infrared controller B = ZN Zone for wall-mounted thermostat or return air control C = ZN Cascade for wall-mounted thermostat or return + supply air control D = Free issued control
15	Free issued control factory-mounted	W = Large empty control box X = Without
16	Valve type	X = Without A = 2-way thermal On/Off B = 3-way thermal On/Off C = 2-way modulating 3 points D = 3-way modulating 3 points
17	Condensate pump	X = Without A = Mounted
18	Fan speed selection	1 = Standard 1-2-4 (refer to table page 18) 2 = Up 2-4-5 (refer to table page 18)
19	Special	X = Without S = With

<sup>(1)</sup> Electric heater sizes 1 and 2 correspond to fan coil size 16.  
Electric heater sizes 3 and 4 correspond to fan coil size 26.  
Electric heater sizes 5 and 6 correspond to fan coil size 36.

## Dimensions

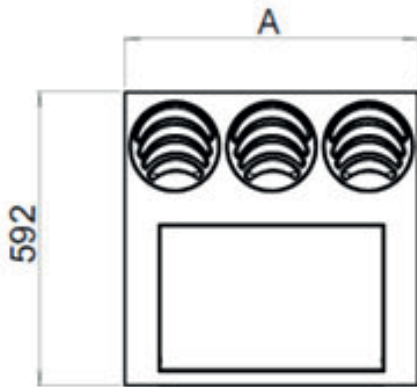

SIZE 16

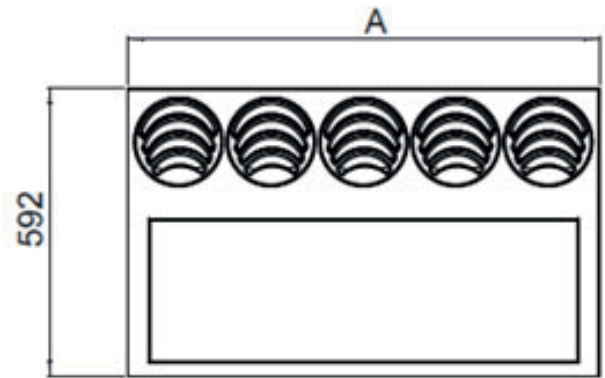

SIZE 26

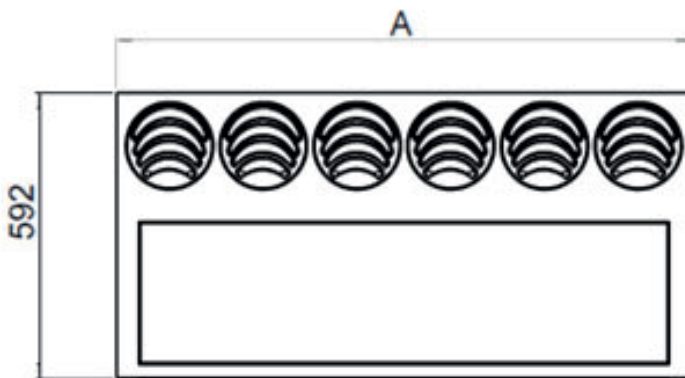

SIZE 36

### Standard height version

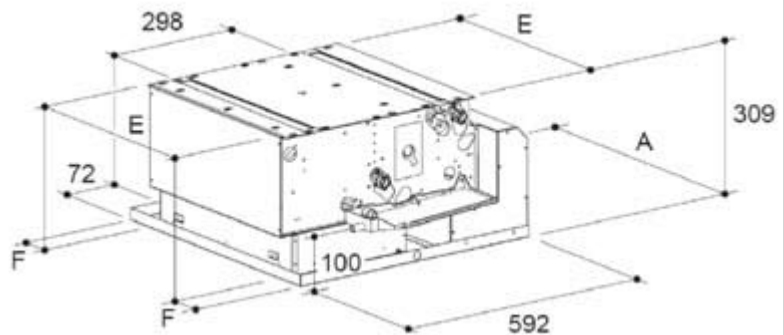

Unit size	Dimensions (mm)		
	A	E	F
16	592	454	78
26	970	884	43
36	1192	1099	46.5

# Dimensions

## Raised height version

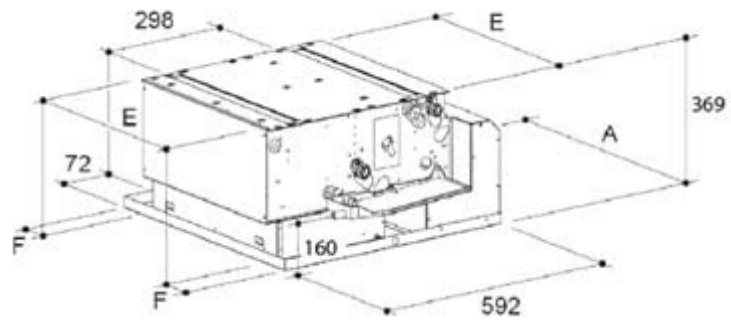

Unit size	Dimensions (mm)		
	A	E	F
16	592	454	78
26	970	884	43
36	1192	1099	46.5

## Access clearances (mm)

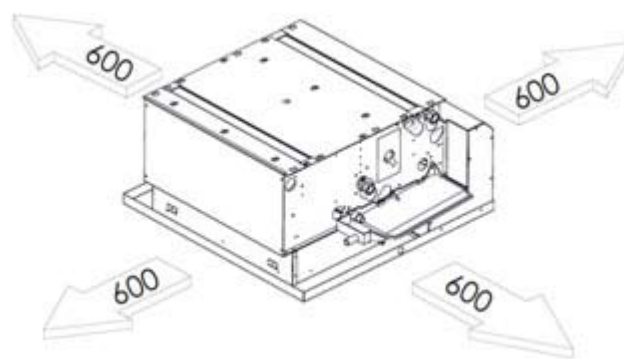



# Dimensions

## Standard height version

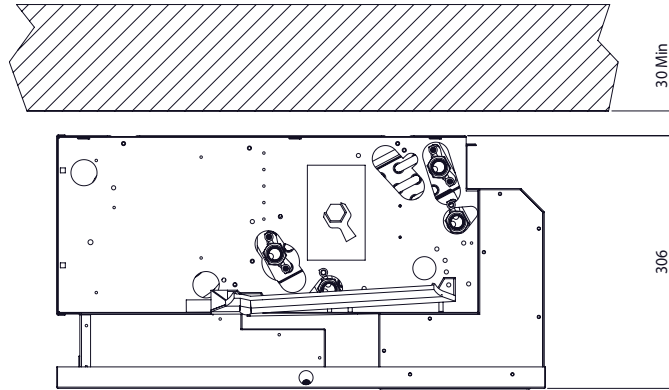

## Raised height version

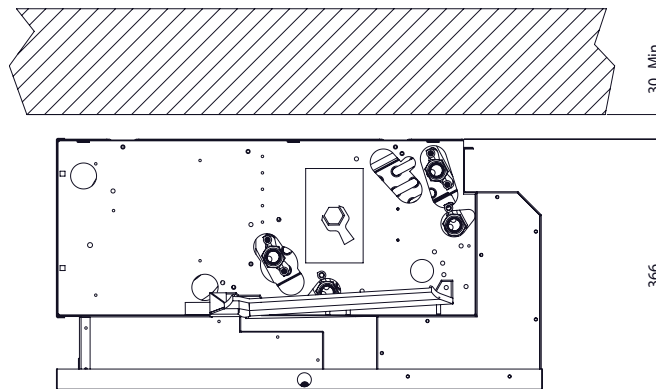

## Packaging

Standard height/raised height version

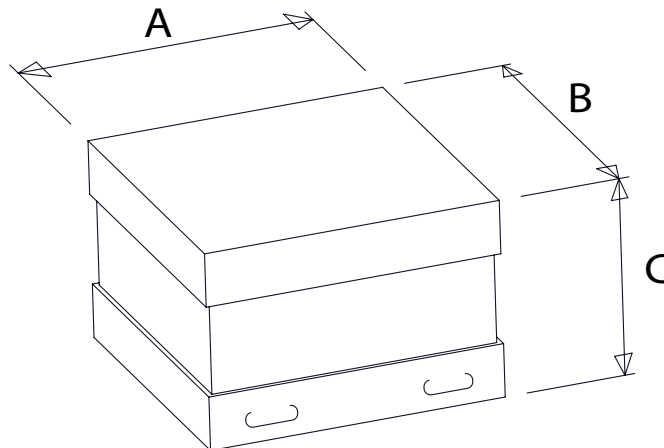

Unit size	16 Std	16 Raised	26 Std	26 Raised	36 Std	36 Raised
A	720	720	1130	1130	1350	1350
B	640	640	640	640	640	640
C	350	410	350	410	350	410





# Dimensions

Weights	Gross weight with packaging (kg)			Net weight (kg)		
	16	26	36	16	26	36
Size						
3 row 2 pipe	18	34	44	16	33	42
3+1 row 4 pipe	20	40	51	19	38	48
3+2 row 4 pipe	23	46	58	22	43	54
4 row 2 pipe	20	37	48	18	35	45
4+1 row 4 pipe	23	42	54	21	40	51

Size	Water Volume (l)		
	16	26	36
3 row main coil	0.6	1.3	1.7
4 row main coil	0.8	1.7	2.4
+1 heating coil	0.2	0.4	0.5
+2 heating coil	0.4	0.8	1.0

	Row			Coil quantity
	3	4	-	
2 pipe	3	4	-	1
4 pipe	3+1	4+1	3+2	2*

\* 4 pipe units have 2 coils. The main coil for cooling has the same cooling performance as the 2 pipe coil for the same number of rows. The additional coil (+1 or +2) is the heating coil with 1 or 2 rows.

Note: The 2 row heating coil provides higher heating performance and is designed to provide higher heating capacities for utilization with heat pump chillers, providing lower hot water temperatures than boilers.



# General data

## 2-pipe units

The following standard rating conditions are used:

### COOLING

Entering air temperature +27°C d.b. +19°C w.b.  
 Water temperature +7/12°C

### HEATING

Entering air temperature +20°C  
 Entering water temperature +50°C  
 water flow rate as for the cooling conditions

Table 2 - CFAS standard efficiency 3 row

		16						26						36					
		1	2	3	4	5	6	1	2	3	4	5	6	1	2	3	4	5	6
Speed	Standard	1	2	3	4	5	6	1	2	3	4	5	6	1	2	3	4	5	6
Speed	Up 2-4-5	1	2	3	4	5	6	1	2	3	4	5	6	1	2	3	4	5	6
Air Flow	m <sup>3</sup> /h	140	180	220	245	280	310	190	230	290	360	445	530	275	335	420	505	600	650
Cooling total emission	kW	0.88	1.06	1.26	1.35	1.50	1.60	1.37	1.62	1.97	2.37	2.81	3.23	1.97	2.37	2.84	3.34	3.75	4.05
Cooling sensible emission	kW	0.66	0.81	0.98	1.06	1.18	1.27	1	1.19	1.47	1.77	2.13	2.47	1.44	1.74	2.11	2.51	2.83	3.07
Heating	kW	1.08	1.33	1.59	1.73	1.93	2.08	1.6	1.91	2.35	2.86	3.43	3.95	2.30	2.79	3.37	4.02	4.53	4.88
ΔP Cooling	kPa	2.4	3.3	4.5	5.1	6.1	6.8	2.9	3.9	5.5	7.6	10.3	13.1	6.4	8.8	12.1	16.2	19.8	22.7
ΔP Heating	kPa	1.8	2.6	3.5	4.0	4.9	5.6	2.3	3.1	4.5	6.3	8.4	10.8	5.2	7.3	9.8	13.4	16.3	18.6
Power consumption	W	16	22	32	38	49	66	24	27	34	44	57	71	38	46	57	69	78	88
Fan amps	A	0.07	0.10	0.14	0.17	0.22	0.30	0.11	0.12	0.15	0.20	0.26	0.32	0.12	0.15	0.19	0.27	0.33	0.38
Sound Power level	dB(A)	35	41	46	49	52	55	33	36	42	48	54	57	35	41	46	52	55	57
Sound Pressure level	dB(A)	26	32	37	40	43	46	24	27	33	39	45	48	26	32	37	43	46	48
NR level	dB(A)	22	27	31	34	38	41	17	18	25	33	40	43	17	24	30	37	40	42
NC level	dB(A)	20	25	30	33	36	39	15	16	23	31	38	41	15	22	28	35	38	41
Dimension (LxWxH)	mm	592x592x309						970x592x310						1192x592x311					
Coil water content	l	0.6						1.3						1.7					

Table 3 - CFAE standard efficiency 3 row

		16					26					36					
		1	2	3	4	5	1	2	3	4	5	1	2	3	4	5	
Speed		1	2	3	4	5	1	2	3	4	5	1	2	3	4	5	
Control Input voltage	V	1	3	5	7.5	10	1	3	5	7.5	10	1	3	5	7.5	10	
Selected speeds		Min		Med			Max			Min		Med			Max		
Air Flow	m <sup>3</sup> /h	130	165	205	250	295	215	295	370	450	540	275	345	430	525	620	
Cooling total emission	kW	0.82	1	1.18	1.37	1.56	1.46	1.92	2.31	2.74	3.16	1.87	2.31	2.78	3.28	3.75	
Cooling sensible emission	kW	0.62	0.76	0.91	1.07	1.24	1.07	1.42	1.73	2.07	2.41	1.37	1.7	2.06	2.45	2.83	
Heating	kW	1.02	1.25	1.5	1.75	2.02	1.72	2.28	2.79	3.33	3.85	2.19	2.72	3.3	3.93	4.54	
ΔP Cooling	kPa	2.1	3	4	5.2	6.5	3.2	5.2	7.3	9.8	12.6	5.8	8.4	11.7	15.7	19.8	
ΔP Heating	kPa	1.7	2.4	3.3	4.3	5.3	2.6	4.2	6	8	10.4	4.7	6.9	9.4	12.9	16.6	
Power consumption	W	8	11	14	21	29	8	11	16	24	37	10	13	19	29	42	
Fan amps		0.04	0.05	0.07	0.1	0.14	0.04	0.05	0.08	0.12	0.18	0.05	0.06	0.09	0.14	0.2	
Sound Power level	dB(A)	35	41	46	51	55	34	40	46	52	56	36	42	48	54	58	
Sound Pressure level	dB(A)	26	32	37	42	46	25	31	37	43	47	27	33	39	45	49	
NR level	dB(A)	22	27	32	37	41	18	22	30	37	42	18	25	33	39	44	
NC level	dB(A)	21	26	30	35	39	17	21	28	35	40	16	24	31	38	42	
Dimension (LxWxH)	mm	592x592x309					970x592x310					1192x592x311					
Coil water content	l	0.6					1.3					1.7					

# General data

Table 4 - CFAS high efficiency 4 row

		16						26						36					
		1	2	3	4	5	6	1	2	3	4	5	6	1	2	3	4	5	6
Speed	Standard	1	2	3	4	5	6	1	2	3	4	5	6	1	2	3	4	5	6
Speed	Up 2-4-5	1	2	3	4	5	6	1	2	3	4	5	6	1	2	3	4	5	6
Air Flow	m <sup>3</sup> /h	140	180	220	245	280	310	190	230	290	360	445	530	275	335	420	505	600	650
Cooling total emission	kW	0.97	1.19	1.44	1.55	1.74	1.87	1.44	1.72	2.12	2.57	3.09	3.58	2.05	2.49	3.00	3.56	4.02	4.36
Cooling sensible emission	kW	0.71	0.88	1.07	1.17	1.31	1.42	1.04	1.24	1.54	1.88	2.28	2.67	1.48	1.81	2.20	2.63	2.98	3.25
Heating	kW	1.14	1.42	1.72	1.88	2.10	2.27	1.69	2.03	2.54	3.12	3.79	4.44	2.38	2.90	3.51	4.20	4.77	5.20
ΔP Cooling	kPa	4.7	6.7	9.2	10.6	12.9	14.6	4.4	6.0	8.6	12.1	16.8	21.7	4.7	6.7	9.3	12.6	15.5	17.9
ΔP Heating	kPa	3.7	5.4	7.6	8.8	10.7	12.3	3.5	4.8	7.1	10.2	13.6	17.9	3.9	5.5	7.3	10.0	12.6	14.6
Power consumption	W	16	22	32	38	49	66	24	27	34	44	57	71	38	46	57	69	78	88
Fan amps	A	0.07	0.10	0.14	0.17	0.22	0.30	0.11	0.12	0.15	0.20	0.26	0.32	0.12	0.15	0.19	0.27	0.33	0.38
Sound Power level	dB(A)	35	41	46	49	52	55	33	36	42	48	54	57	35	41	46	52	55	57
Sound Pressure level	dB(A)	26	32	37	40	43	46	24	27	33	39	45	48	26	32	37	43	46	48
NR level	dB(A)	22	27	31	34	38	41	17	18	25	33	40	43	17	24	30	37	40	42
NC level	dB(A)	20	25	30	33	36	39	15	16	23	31	38	41	15	22	28	35	38	41
Dimension (LxWxH)	mm	592x592x309						970x592x310						1192x592x311					
Coil water content	l	0.8						1.7						2.4					

Table 5 - CFAE high efficiency 4 row

		16						26						36					
		1	2	3	4	5	6	1	2	3	4	5	6	1	2	3	4	5	6
Speed		1	2	3	4	5	6	1	2	3	4	5	6	1	2	3	4	5	6
Control Input voltage	V	1	3	5	7.5	10		1	3	5	7.5	10		1	3	5	7.5	10	
Selected speeds		Min		Med		Max		Min		Med		Max		Min		Med		Max	
Air Flow	m <sup>3</sup> /h	130	165	205	250	295	215	295	370	450	540	275	345	430	525	620			
Cooling total emission	kW	0.91	1.12	1.34	1.58	1.81	1.55	2.06	2.51	3	3.5	1.95	2.42	2.94	3.49	4.02			
Cooling sensible emission	kW	0.66	0.82	0.99	1.18	1.38	1.11	1.49	1.84	2.21	2.6	1.41	1.76	2.15	2.57	2.98			
Heating	kW	1.07	1.32	1.6	1.9	2.2	1.82	2.46	3.03	3.68	4.32	2.25	2.82	3.44	4.12	4.78			
ΔP Cooling	kPa	4.1	5.9	8.1	10.9	13.9	5	8.2	11.6	15.9	20.8	4.3	6.4	8.9	12.1	15.5			
ΔP Heating	kPa	3.3	4.8	6.6	9	11.6	4.1	6.7	9.4	13.2	17.1	3.5	5.2	7.4	10	13			
Power consumption	W	8	11	14	21	29	8	11	16	24	37	10	13	19	29	42			
Sound Power level	dB(A)	35	41	46	51	55	34	40	46	52	56	36	42	48	54	58			
Sound Pressure level	dB(A)	26	32	37	42	46	25	31	37	43	47	27	33	39	45	49			
NR level	dB(A)	22	27	32	37	41	18	22	30	37	42	18	25	33	39	44			
NC level	dB(A)	21	26	30	35	39	17	21	28	35	40	16	24	31	38	42			
Dimension (LxWxH)	mm	592x592x309						970x592x310						1192x592x311					
Coil water content	l	0.8						1.7						2.4					



# General data

## 4-pipe units 3+1

The following standard rating conditions are used:

### COOLING

Entering air temperature      +27°C d.b.      +19°C w.b.  
 Water temperature              +7/12°C

### HEATING

Entering air temperature      +20°C  
 Water temperature:            +70/60°C

Table 6 - CFAS standard efficiency 3 + 1 row

CFAS standard efficiency	16						26						36						
Speed	1	2	3	4	5	6	1	2	3	4	5	6	1	2	3	4	5	6	
Selected speeds	6	5	4	3	2	1	6	5	4	3	2	1	6	5	4	3	2	1	
Air Flow	m <sup>3</sup> /h	140	180	220	245	280	310	190	230	290	360	445	530	275	335	420	505	600	650
Cooling total emission	kW	0.88	1.06	1.26	1.35	1.50	1.60	1.37	1.62	1.97	2.37	2.81	3.23	1.97	2.37	2.84	3.34	3.75	4.05
Cooling sensible emission	kW	0.66	0.81	0.98	1.06	1.18	1.27	1	1.19	1.47	1.77	2.13	2.47	1.44	1.74	2.11	2.51	2.83	3.07
Heating	kW	0.92	1.08	1.25	1.34	1.47	1.56	1.49	1.71	2.02	2.35	2.73	3.07	2.12	2.47	2.87	3.30	3.64	3.89
ΔP Cooling	kPa	2.4	3.3	4.5	5.1	6.1	6.8	2.9	3.9	5.5	7.6	10.3	13.1	6.4	8.8	12.1	16.2	19.8	22.7
ΔP Heating	kPa	1.6	2.1	2.7	3.1	3.6	4.0	0.9	1.2	1.6	2	2.6	3.2	2.0	2.6	3.4	4.3	5.1	5.8
Power consumption	W	16	22	32	38	49	66	24	27	34	44	57	71	38	46	57	69	78	88
Fan amps	A	0.07	0.10	0.14	0.17	0.22	0.30	0.11	0.12	0.15	0.20	0.26	0.32	0.12	0.15	0.19	0.27	0.33	0.38
Sound Power level	dB(A)	35	41	46	49	52	55	33	36	42	48	54	57	35	41	46	52	55	57
Sound Pressure level	dB(A)	26	32	37	40	43	46	24	27	33	39	45	48	26	32	37	43	46	48
NR level	dB(A)	22	27	31	34	38	41	17	18	25	33	40	43	17	24	30	37	40	42
NC level	dB(A)	20	25	30	33	36	39	15	16	23	31	38	41	15	22	28	35	38	41
Dimension (LxWxH)	mm	592x592x309						970x592x310						1192x592x311					
Coil water content	l	0.6						1.3						1.7					
Coil water content heating	l	0.2						0.4						0.5					

Table 7 - CFAE standard efficiency 3+1 row

	16					26					36					
Speed	1	2	3	4	5	1	2	3	4	5	1	2	3	4	5	
Control Input voltage	V	1	3	5	7.5	10	1	3	5	7.5	10	1	3	5	7.5	10
Selected speeds	Min	Med			Max	Min	Med			Max	Min	Med			Max	
Air Flow	m <sup>3</sup> /h	130	165	205	250	295	215	295	370	450	540	275	345	430	525	620
Cooling total emission	kW	0.82	1	1.18	1.37	1.56	1.46	1.92	2.31	2.74	3.16	1.87	2.31	2.78	3.28	3.75
Cooling sensible emission	kW	0.62	0.76	0.91	1.07	1.24	1.07	1.42	1.73	2.07	2.41	1.37	1.7	2.06	2.45	2.83
Heating	kW	0.87	1.03	1.18	1.35	1.52	1.58	1.97	2.31	2.66	3.01	2.04	2.42	2.82	3.24	3.64
ΔP Cooling	kPa	2.1	3	4	5.2	6.5	3.2	5.2	7.3	9.8	12.6	5.8	8.4	11.7	15.7	19.8
ΔP Heating	kPa	1.4	1.9	2.5	3.1	3.8	1	1.5	2	2.5	3.1	1.8	2.5	3.3	4.2	5.1
Power consumption	W	8	11	14	21	29	8	11	16	24	37	10	13	19	29	42
Sound Power level	dB(A)	35	41	46	51	55	34	40	46	52	56	36	42	48	54	58
Sound Pressure level	dB(A)	26	32	37	42	46	25	31	37	43	47	27	33	39	45	49
NR level	dB(A)	22	27	32	37	41	18	22	30	37	42	18	25	33	39	44
NC level	dB(A)	21	26	30	35	39	17	21	28	35	40	16	24	31	38	42
Dimension (LxWxH)	mm	592x592x309					970x592x310					1192x592x311				
Coil water content	l	0.6					1.3					1.7				
Coil water content heating	l	0.2					0.4					0.5				

## General data

### 4 pipe units 3+2

The following standard rating conditions are used:

#### COOLING

Entering air temperature      +27°C d.b.      +19°C w.b.  
 Water temperature              +7/12°C

#### HEATING

Entering air temperature      +20°C  
 Water temperature:            +60/50°C

Table 8

CFAS high efficiency heating coil	16						26						36						
	1	2	3	4	5	6	1	2	3	4	5	6	1	2	3	4	5	6	
Speed	1	2	3	4	5	6	1	2	3	4	5	6	1	2	3	4	5	6	
Selected speeds	6	5	4	3	2	1	6	5	4	3	2	1	6	5	4	3	2	1	
Air Flow	m <sup>3</sup> /h	140	180	220	245	280	310	190	230	290	360	445	530	275	335	420	505	600	650
Cooling total emission	kW	0.88	1.06	1.26	1.35	1.50	1.60	1.37	1.62	1.97	2.37	2.81	3.23	1.97	2.37	2.84	3.34	3.75	4.05
Cooling sensible emission	kW	0.66	0.81	0.98	1.06	1.18	1.27	1	1.19	1.47	1.77	2.13	2.47	1.44	1.74	2.11	2.51	2.83	3.07
Heating	kW	1.16	1.38	1.63	1.75	1.92	2.05	1.79	2.11	2.55	3	3.53	4.03	2.57	3.07	3.65	4.22	4.70	5.06
ΔP Cooling	kPa	2.4	3.3	4.5	5.1	6.1	6.8	2.9	3.9	5.5	7.6	10.3	13.1	6.4	8.8	12.1	16.2	19.8	22.7
ΔP Heating	kPa	4.5	6.0	8.1	9.1	10.8	12.2	2.4	3.2	4.5	6	8	10	5.4	7.4	10.0	12.9	15.6	17.8
Power consumption	W	16	22	32	38	49	66	24	27	34	44	57	71	38	46	57	69	78	88
Fan amps	A	0.07	0.10	0.14	0.17	0.22	0.30	0.11	0.12	0.15	0.20	0.26	0.32	0.12	0.15	0.19	0.27	0.33	0.38
Sound Power level	dB(A)	35	41	46	49	52	55	33	36	42	48	54	57	35	41	46	52	55	57
Sound Pressure level	dB(A)	26	32	37	40	43	46	24	27	33	39	45	48	26	32	37	43	46	48
NR level	dB(A)	22	27	31	34	38	41	17	18	25	33	40	43	17	24	30	37	40	42
NC level	dB(A)	20	25	30	33	36	39	15	16	23	31	38	41	15	22	28	35	38	41
Dimension (LxWxH)	mm	592x592x309						970x592x310						1192x592x311					
Coil water content cooling	l	0.6						1.3						1.7					
Coil water content heating	l	0.4						0.8						1.0					

### Correction factor for cooling capacities and relative humidity

Total capacity				
Water (°C)	Air (°C)	25-18	26-18.5	28-20
7/12 °C	K	0.82	0.89	1.11
10/15 °C	K	0.56	0.63	0.82
14/18 °C	K	0.35	0.41	0.52
Sensible capacity				
Water (°C)	Air (°C)	25-18	26-18.5	28-20
7/12 °C	K	0.90	0.94	1.06
10/15 °C	K	0.72	0.78	0.90
14/18 °C	K	0.50	0.58	0.72

To be used based on Eurovent cooling rating conditions 27°C/19°C and 50% RH ambient temperature and 12/7°C cooling water temperatures.

## General data

### Operating limits

Maximum entering water temperature: +80°C.  
 Minimum water temperature without glycol: +5°C.  
 For lower water temperatures please contact your local sales office.  
 Maximum water operating pressure: 1000 kPa (10 bars).

Water flow cooling coil				
Size		16	26	36
3-row	Minimum	100	150	150
	Maximum	500	1000	1500
4-row	Minimum	100	150	200
	Maximum	750	1000	2000

Water flow heating coil				
Size		16	26	36
+1	Minimum	50	100	100
	Maximum	250	450	650
+2	Minimum	50	100	100
	Maximum	250	450	650

Electrical motor maximum power input	AC fan motor			
	16	26	36	
230/1/50	W	66	71	84
	A	0.30	0.32	0.38
	EC fan motor			
	W	29	37	42

A = Heating  
 B = Cooling

### Air throw distances

(A)

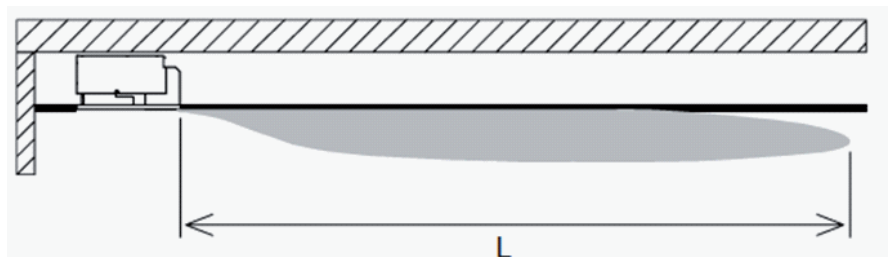

(B)

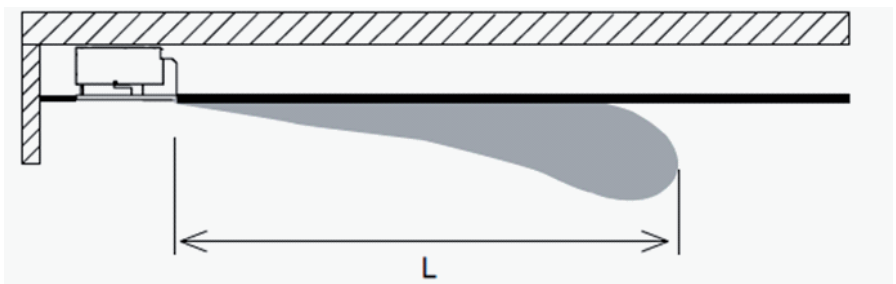

		16						26						36					
Speed		1	2	3	4	5	6	1	2	3	4	5	6	1	2	3	4	5	6
Throw (L) (m)	Heating	3.8	4.5	5.8	6.3	6.8	7.2	4.0	5.0	6.1	7.0	8.0	9.0	4.5	5.2	6.3	7.5	8.8	9.5
	Cooling	3.0	3.6	4.6	5.0	5.4	5.7	3.2	4.0	4.8	5.6	6.0	7.2	3.6	4.1	5.0	6.0	7.0	7.6

# Sound spectrum

Table 9 - CFAS

	Speed	m <sup>3</sup> /h	Sound Power level Frequency octave band LWA							Sound Pressure				
			125	250	500	1000	2000	4000	8000	Glob	(*) Lp	(*) NC	NR	NC
16	1	105	18.3	29.1	28.2	31	24.3	18.1	15.1	35.0	26	22	22	20
	2	125	24.5	34.3	36.6	35.8	29.5	22.4	16.5	41.0	32	28	27	25
	3	150	29.1	38.8	42	40.4	35.8	28.7	19.5	46.0	37	33	31	30
	4	175	31.8	41.4	44.9	43.5	39.4	32.3	22.2	49.0	40	36	34	33
	5	195	34.7	44	47.7	46.6	43.3	36.9	26.8	52.0	43	39	38	36
	6	220	37.7	46.9	50.4	49.7	46.8	40.7	31	55.0	46	42	41	39
26	1	145	27.2	27.6	25.2	21.1	21.8	19.9	18.5	32.7	24	20	17	15
	2	170	30.3	30.1	29.5	25	23.4	20.8	19.2	35.7	27	23	18	16
	3	220	28.1	36.7	37.4	34.1	30.6	24.8	19.5	41.7	33	29	25	23
	4	250	33.3	40.9	43.6	41.3	38.5	29.2	21.6	47.7	39	35	33	31
	5	295	38.6	46.9	49.2	48.5	45.6	36.8	25.9	54.0	45	41	40	38
	6	340	41.5	48.9	52.2	51.8	49.2	41.3	29.6	57.0	48	44	43	41
36	1	185	24	31.3	30	24.1	20	15.2	18.3	34.9	26	22	17	15
	2	235	28.9	36.5	36.7	32.9	26.3	18	18.6	40.9	32	28	24	22
	3	270	32.2	40.2	41.9	39	33.1	22.8	19.2	45.8	37	33	30	28
	4	325	37.6	45.1	47.9	45.6	40.9	31.1	22.3	51.8	43	39	37	35
	5	385	40.2	47.7	50.6	48.9	45.3	36.4	26.5	54.8	46	42	40	38
	6	440	41.6	49.1	52.3	51.2	47.8	39.6	29.7	56.7	48	44	42	41

Table 10 - CFAE

	Volt	Speed	m <sup>3</sup> /h	Sound Power level Frequency octave band LWA							Sound Pressure			
				125	250	500	1000	2000	4000	8000	Glob	(*) Lp	(*) NC	NR
16	1	1	130	18.3	29.1	28.2	31	24.3	18.1	15.1	35.0	26	22	21
	3	2	165	24.5	34.3	36.6	35.8	29.5	22.4	16.5	41.0	32	27	26
	5	3	205	29.1	38.8	42	40.4	35.8	28.7	19.5	46.0	37	32	30
	7.5	4	250	33.8	43.1	46.9	45.5	41.4	34.3	24.2	50.9	42	37	35
	10	5	295	37.7	47	50.7	49.6	46.2	39.9	29.8	55.0	46	41	39
26	1	1	215	28.4	28.8	26.4	22.4	23.1	21.2	19.8	34.0	25	18	17
	3	2	295	34.6	34.4	33.8	29.3	27.7	25.1	23.5	40.0	31	22	21
	5	3	370	32.4	41.0	41.7	38.4	34.9	29.1	23.8	46.0	37	30	28
	7.5	4	450	37.6	45.2	47.9	45.6	42.8	33.5	25.9	52.0	43	37	35
	10	5	540	40.6	48.9	51.2	50.5	47.6	38.8	27.9	56.0	47	42	40
36	1	1	275	25.1	32.4	31.1	25.2	21.1	16.3	19.4	36.0	27	18	16
	3	2	345	30.0	37.6	37.8	34.0	27.4	19.1	19.7	42.0	33	25	24
	5	3	430	34.4	42.4	44.1	41.2	35.3	25.0	21.4	48.0	39	33	31
	7.5	4	525	39.8	47.3	50.1	47.8	43.1	33.3	24.5	54.0	45	39	38
	10	5	620	43.4	50.9	53.8	52.1	48.5	39.6	29.7	58.0	49	44	42

(\*)Note: The sound pressure levels Lp and NC are determined with the following assumptions:  
 - a room absorption of 9 dB(A) for a room of 100 m with a reverbering time of 0,5 sec  
 - units complete of filter, coil and fan sections



# Water pressure drop

## Water pressure drop - coils

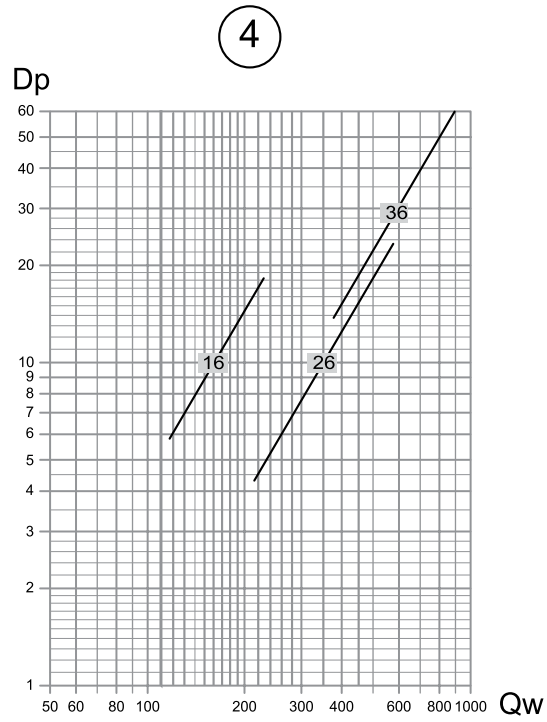
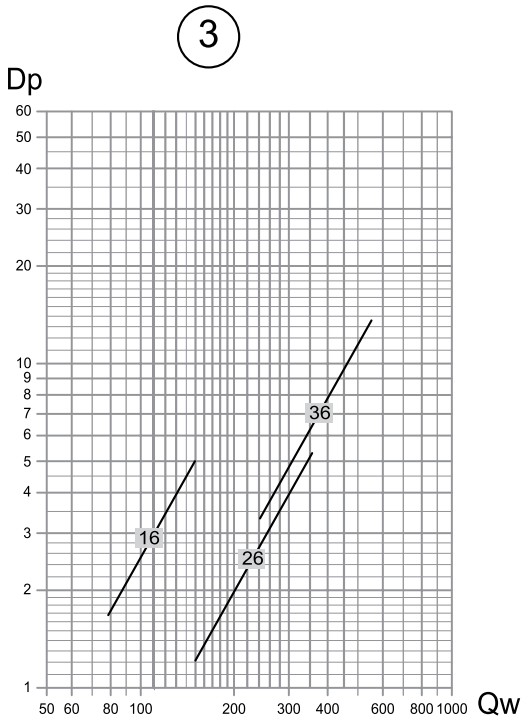
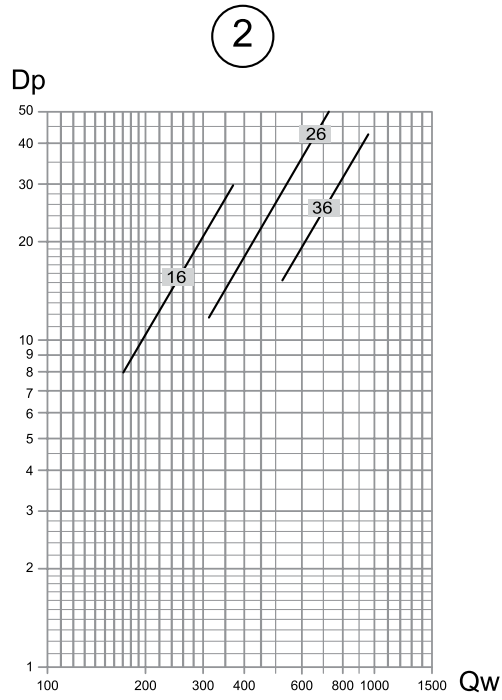
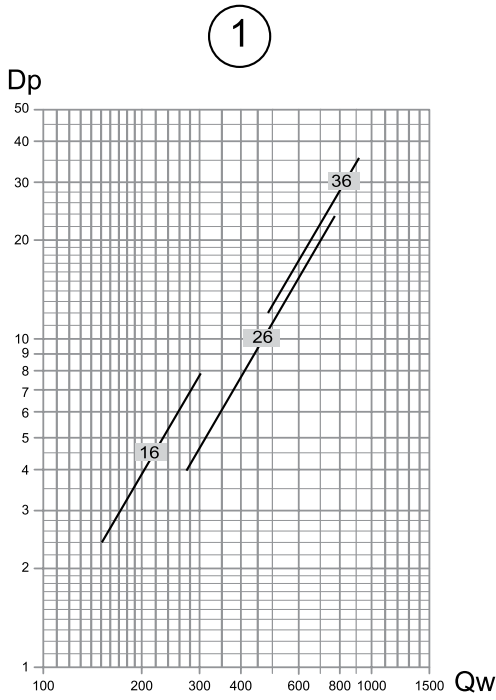

- 1 = 3-row coil
- 2 = 4-row coil
- 3 = Additional row +1
- 4 = Additional row +2



# Water pressure drop

## Water pressure drop - valves

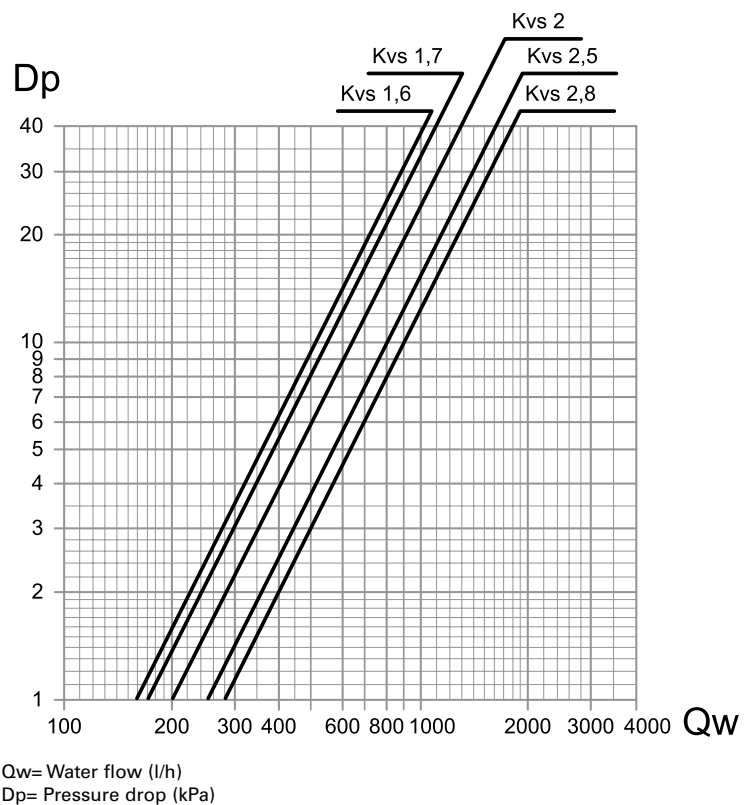

Valve type	Coil	Unit size	DN	Diameter	Kvs	Factory mounted
2 way	Cooling	16-26	15	1/2	1.7	Yes
		36	20	3/4	2.8	
	Heating	16-26-36	15	1/2	1.7	
		16-26	15	1/2	1.6	
3 way	Cooling	36	20	3/4	2.5	Yes
		16-26-36	15	1/2	1.6	
3 way lockshield <sup>(1)</sup>	Cooling	16-26	15	1/2	1.6	No
		36	20	3/4	2.5	
	Heating	16-26-36	15	1/2	1.6	

<sup>(1)</sup> Available only as an accessory for field mounting

# Options

## Options

### Access side configuration

The unit can be delivered with the water valve package on the right or left hand side. The control box is always mounted on the opposite side of the water valve package. There are 2 precut circles in the sheet metal for fresh air intake, one each side of the unit. The one to be used is opposite side of the control box, same side as the water valve package.

Electrical connections side

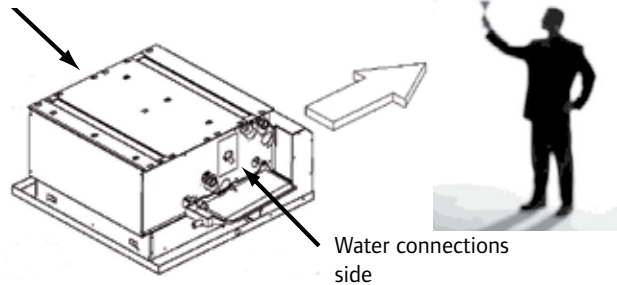

### Raised height version

These models are specifically designed for installation where gravity condensate drainage is a priority. The unit plenum height is increased by 60 mm such the drain outlet connection is 160 mm above the false ceiling structure.

### Fan speed (AC fan motor)

All unit models have a 6 fan speed motor, 3 of which are connected in the factory. There are 2 possibilities for factory default speed setting (standard and “up 2-4-5”). The fan speed selection can be changed on site by moving the speed wire from the quick connect terminal strip to the ones on the motor auto-transformer. The access is completed easily through the return air access door.

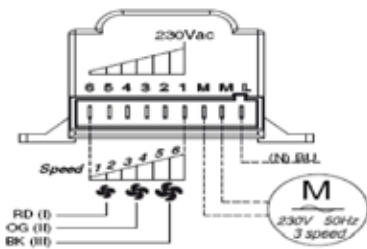

### Fan speed (EC fan motor)

The fan speed varies in function of the control input voltage from 1 to 10 volts direct current.

**Selection table - CFAS**

Unit size	Row	Speed	16						26						36					
			1	2	3	4	5	6	1	2	3	4	5	6	1	2	3	4	5	6
3		Standard 1-2-4	x	x			x		x	x			x			x		x	x	
		Up 2-4-5		x		x	x			x	x	x			x		x	x	x	
4		Standard 1-2-4	x	x			x		x	x			x			x		x	x	
		Up 2-4-5		x		x	x			x	x	x			x		x	x	x	
3+1		Standard 1-2-4	x	x			x		x	x			x			x		x	x	
		Up 2-4-5		x		x	x			x	x	x			x		x	x	x	
4+1		Standard 1-2-4	x	x			x		x	x			x			x		x	x	
		Up 2-4-5		x		x	x			x	x	x			x		x	x	x	
3+2		Standard 1-2-4	x	x			x		x	x			x			x		x	x	
		Up 2-4-5		x		x	x			x	x	x			x		x	x	x	

# Options

## Filter

Two options available easy removable without any tool, the standard version is classified G0 made of polypropylene honeycomb design. It is washable. A factory-mounted optional filter class EU3 made of 8 mm thick polyester media mounted on a metallic frame is also available

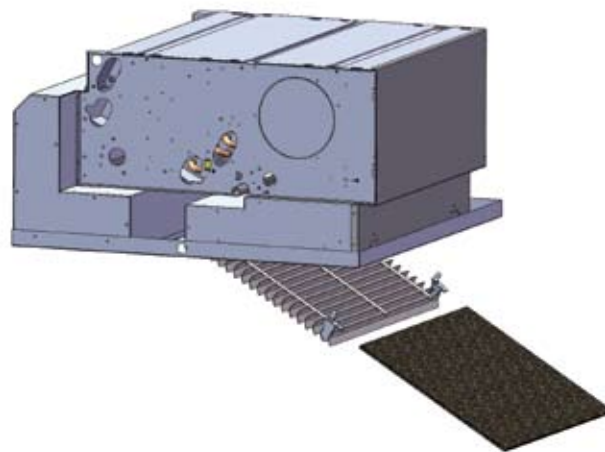

## Water valve cooling and heating

2-way and 3-way water valves for the cooling and heating coil are available factory-mounted with all control options. Water valves are delivered with thermal actuator using hot wax motor. There is also a modulating water valve actuator available with the Trane Tracer ZN controller for both 2 and 4-pipe applications. When configured in cascade control it will limit in cooling mode the discharge air temperature to avoid cold air drafts for a better ambient control and improved comfort.

### Water valve pressure drop data

	Unit size	DN	Valve	
			Diameter (inches)	Kvs
Cooling coil	16-26	15	1/2"	1.6
	36	20	3/4"	2.5
Heating coil	all	15	1/2"	1.6

# Options

## Water valve location - standard height version

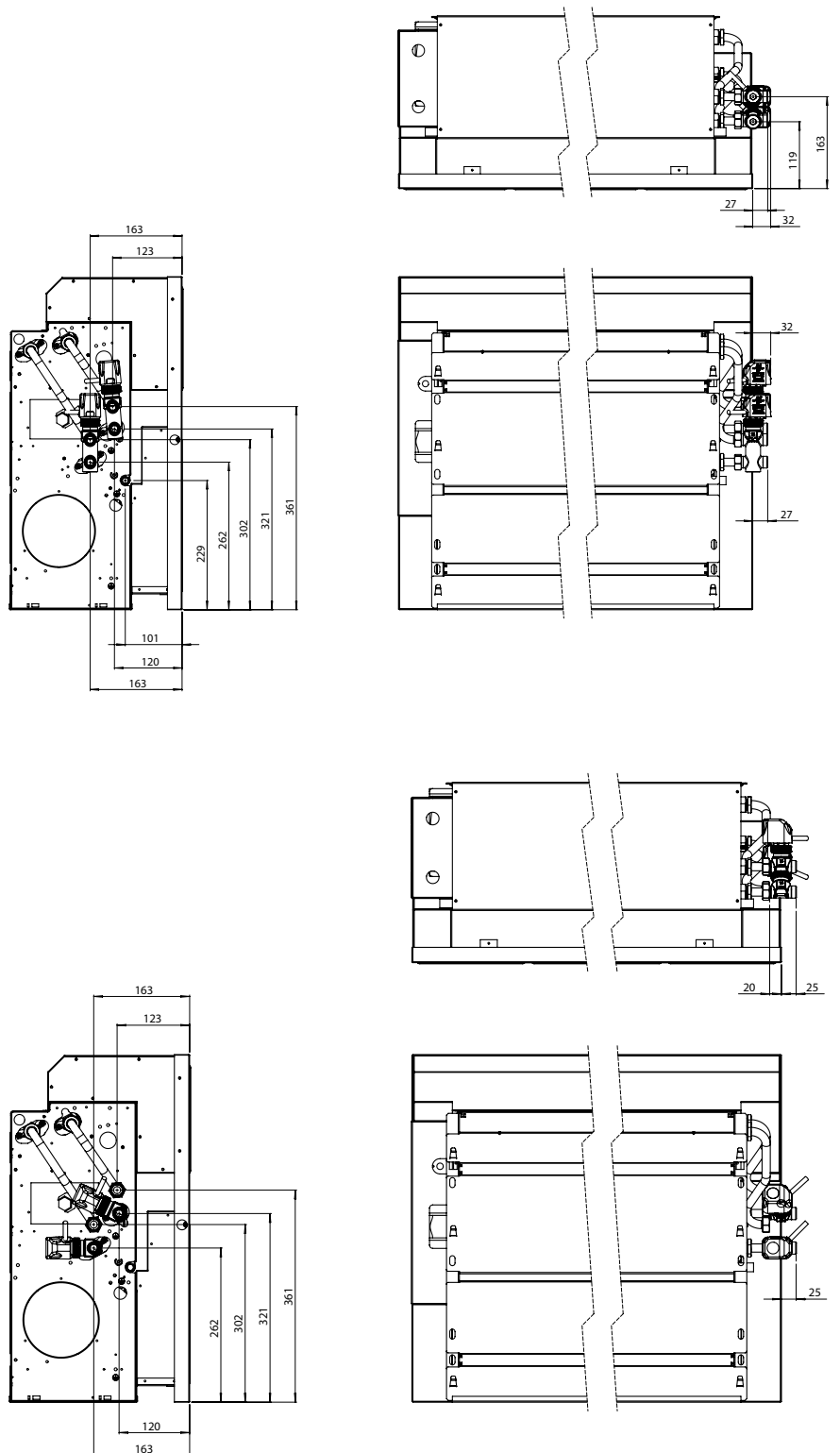

# Options

## Water valve location - raised height version

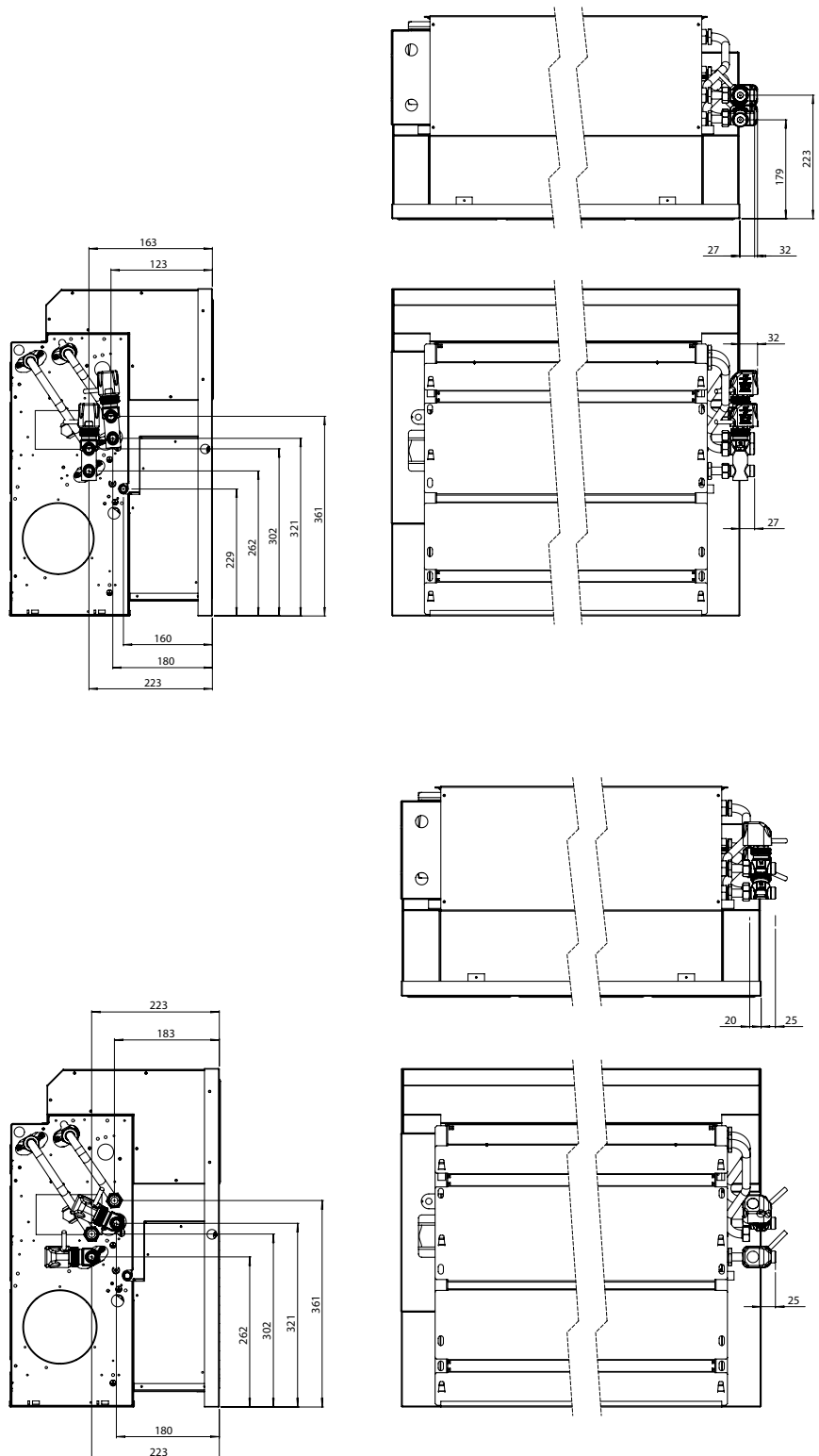

## Options

### On/off valves with hot wax actuator

In order to save time on the job site, on/off 2 way and 3 way valves are available as a pre-assembled kits including pipes and connections.

3 Way / 4 ports



2 Way / 2 ports

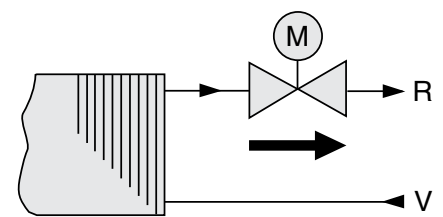
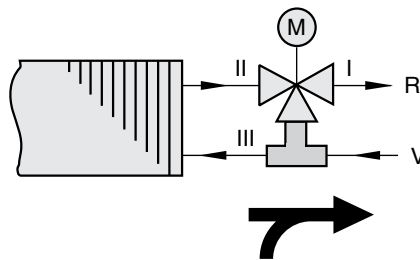

Valve type	Coil	Unit size	DN	Accessory reference	Factory mounted
2 way	Cooling	16-26	15	35169809-001	Yes
		36	20	35169810-001	
	Heating	16-26-36	15	35169809-001	
3 way	Cooling	16-26	15	35169806-001	Yes
		36	20	35169807-001	
	Heating	16-26-36	15	35169806-001	
3 way lockshield	Cooling	16-26	15	35169803-001	No
		36	20	35169804-001	
	Heating	16-26-36	15	35169803-001	

# Options

## Electric heater

The electric heater is made of a sealed bar heater inserted into an aluminum louvered radiator to deliver an optimum homogeneous temperature. Models CFAS/ CFAE 16 and 26 have an automatic reset cut-out thermostat setting to 190°C and size 36 setting at 160°C directly fixed on the electric heater element. In addition there is a manual reset cut-out thermostat with a temperature setting of 80°C.

All units with electric heater have a galvanized painted drain pan such avoiding damage to the unit in case of partial or complete loss of airflow before the thermostat tripping is completed.

## Factory-mounted controls

Three types of controls are available:

1. **Standalone** applications where one thermostat interface is used for each individual unit. The unit is equipped with a terminal strip in the control box to which the remote wall mounted thermostat need to be connected. There is the possibility to connect another unit using the relay card for the fan speed control: model RELO3 for thermostat models N, P, R, T and RELO2 for thermostat model U for the AC fan motor unit type. For the EC fan motor unit type, the T-EC thermostat can control up to 16 units each equipped with the RELO4 accessory card.
2. **Group control** where one user interface is used for several units installed and connected together through a serial link RS485 using a ModBus communication protocol. Up to 20 units can be connected to each other. Please refer to the installation manual for this. The ambient air temperature can be controlled via the indoor sensor installed on the T-MB wall mount thermostat interface or through the return air sensor of each individual unit. There is also the possibility to install an infrared receiver with a handset transmitter field installed. The ambient temperature is then controlled via the return air sensor of each individual unit.
3. **Building Management System** for office building where all equipment shall be supervised by a main control system. The air ambient temperature can be controlled via communicating wall mounted thermostat, or equipment return air sensor.

The Tracer™ ZN 523 and 525 BMS is factory-configured for the customer's requirements and uses ZSM10 and ZSM11 wall thermostats. Contact your Trane controls sales engineer for more information.

Unit size		16		26		36	
Emission	W	350	550	700	1150	900	1400
Supply	V/Ph/Hz	230/1/50					
Amperage	A	1.5	2.4	3	3.9	3.9	6.1
Wire gage	mm <sup>2</sup>	3 x 1.5					

## Condensate pump

The reciprocating condensate pump can be factory mounted. It is very quiet and doesn't affect the unit's sound performance. The water drainage performance depends upon elevation and pipe horizontal length.

Elevation (m)	Water flow function of horizontal length and vertical elevation	
	5 m	10 m
1	6.80	6.30
2	5.50	5.00
3	4.20	3.80
4	3.00	2.60

Note: the drain pan is delivered with the factory-mounted condensate pump.



# Control options

Installation	Control type	Architecture	2 pipe				4 pipes				
			Only	Only	Changeover type(s)		Water Valve(s)				
			Cool	Heat	Cool / Heat	Cool + Electric heat	Cool / Heat + Electric heat	Cool / Heat	Hotwax	3 points	
AC fan motor	N	Wall thermostat (wires)	x	x	Manual	Manual		manu	x		
			x	x	auto (SP*+WT*)	auto (SP)	auto (SP+WT)	auto (SP)	x		
	R	Wall thermostat (wires)	x	x	Manual	Manual		Manual	x		
			x	x	External	External		External	x		
			x	x	Auto (WT)				x		
	T	Wall thermostat (wires)	x	x	Manual	Manual		Manual	x		
			x	x	External	External		External	x		
			x	x	Auto (WT)	auto (SP)		auto (SP)	x		
	U	Unit controller + wall LCD thermostat (bus)	x	x	Manual	Manual		Manual	x		
			x	x	External	External		External	x		
			x	x	auto (WT)	auto (SP)		auto (SP)	x		
	Group control	MB-AC + T-MB	Unit controller + wall thermostat (bus) or infrared remote controller	x	x	Manual	Manual	Manual	Manual	x	
				x	x	External	External	External	External	x	
				x	x	auto (WT)	auto (SP)	auto (SP+WT)	auto (SP)	x	
	BMS	ZN523	Unit controller + wall thermostat (bus)	x		auto (WT)	auto (SP)	auto (WT)	auto (SP)	x	x
EC fan motor	Standalone	T-EC	Unit controller + wall thermostat (bus)	x	x	Manual	Manual		Manual	x	
				x	x	External	External		External	x	
				x	x	auto (WT)	N/A		N/A	x	
	Group control	MB-EC + T-MB	Unit controller + wall thermostat (bus) or infrared remote controller	x	x	Manual	Manual	Manual	Manual	x	
				x	x	External	External	External	External	x	
						auto (WT)	auto (SP)	auto (SP+WT)	auto (SP)	x	
BMS	ZN525	Unit controller + wall thermostat (bus)	x		auto (WT)	auto (SP)	auto (WT)	auto (SP)	x	x	

- SP Change over based on air temperature set point
- WT Change over based on water temperature set point 15 / 25 °C
- RAT Return air temperature sensor
- N/A Not available
- LCD Liquid cell display
- MHW Minimum hot water temperature control





# Control options

Installation	Control type	Architecture	Master/slave communication			Extra features							
			Accessory	Type	Control capability (number of units)	Return air temperature sensor	MHW	Economy override	Window contact	Remote on/off	Time of day scheduler	Control external equipment	
AC fan motor	N	Wall thermostat (wires)	Relay card	RELO3	wires	10							
	P	Wall thermostat (wires)	Relay card	RELO3	wires								
	Standalone	R	Wall thermostat (wires)	Relay card	RELO3	wires	10		x				
	T	Wall thermostat (wires)	Relay card	RELO3	wires	10		x					
	U	Unit controller + wall LCD thermostat (bus)	Relay card	RELO2	Proprietary RS485	10		x	x				
Group control	MB-AC + T-MB	Unit controller + wall thermostat (bus) or infrared remote controller	Unit controller		Mod-Bus RS485	20	x	x	X	x	x	TODS	ECC
BMS	ZN523	Unit controller + wall thermostat (bus)	ZN523		LonTalk RS485	30+	x	x	x	x			
EC fan motor	Standalone	T-EC	Unit controller + wall thermostat (bus)	Relay card	RELO4	Mod-Bus RS485	16	x	x		x		
	Group control	MB-EC + T-MB	Unit controller + wall thermostat (bus) or infrared remote controller	Unit controller		Mod-Bus RS485	20	x	x	x	x	TODS	ECC
		ZN525	Unit controller + wall thermostat (bus)	ZN525		LonTalk RS485	30+	x		x	x		

MHW Minimum hot water temperature control

## Standalone controls

---

### Thermostat N - AC fan motor

(Accessory 35169830-001)

CONTROL WITH ELECTROMECHANIC  
THERMOSTAT

Figure 1 - Thermostat N



Main characteristics:

- On/off switch.
- Manual speed switch.
- Manual Summer/Winter switch.
- Temperature setting

Operation:

- 1-step heating
- 1-step cooling
- Controls one water valve ON-OFF for cooling
- Controls one electric heater or one water valve ON-OFF for heating
- Fan runs continuously regardless of water valve operation when the thermostat is turned ON.

## Standalone controls

---

### Thermostat P - AC fan motor

ELECTROMECHANIC THERMOSTAT

AUTO CHANGEOVER + ELECTRIC  
HEATER

(Accessory 35169831-001)

Figure 2 - Thermostat P



Main characteristics:

- On/off switch.
- Manual speed switch.
- Automatic Summer/Winter change-over.
- Temperature setting

Operation:

- 2-step heating
- 1-step cooling
- Controls one water valve ON-OFF for cooling
- Controls one water valve ON-OFF for heating
- Controls one electric heater as second step heating
- Fan runs continuously regardless of water valve operation when the thermostat is turned ON.

## Standalone controls

---

### Thermostat R - AC fan motor

STANDALONE CONTROL WITH  
ELECTRONIC THERMOSTAT MANUAL  
CHANGEOVER

(Accessory 35169833-001)

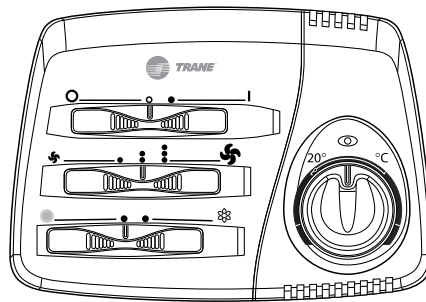

Main characteristics:

- On/off switch.
- Manual speed switch.
- Manual change mode switch.
- Temperature setting
- Water temperature sensor to avoid cold air drafts in heating mode.

Operation:

- 1-step heating
- 1-step cooling
- Controls one water valve ON/OFF for cooling
- Controls one water valve ON/OFF or one electric heater for heating
- Fan runs continuously regardless of water valve operation when the thermostat is turned ON.
- With the water temperature sensor accessory MHW, cold air drafts are avoided in cases where the hot water temperature is lower than 38°C.

# Standalone controls

---

## Thermostat T - AC fan motor

CONTROL WITH ELECTRONIC  
THERMOSTAT

(Accessory 35169834-001)

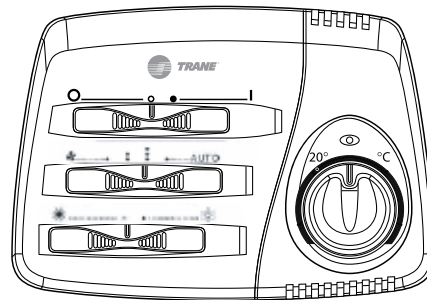

### Main characteristics:

Same characteristics as the R control,  
adding:

- Manual or automatic speed switch.
- Electronic thermostat for fan control (on/off).
- Electronic thermostat for valve(s) control (on/off).
- Simultaneous thermostatic control on the valves and fan (on/off).
- It allows installation of the Summer/Winter switch centralized and remote, or to control it with an automatic change-over fitted on the water pipe (for 2 pipe installations only). The last case needs the adjustment of the jumper on the control board (see the instruction leaflet supplied with the control).

## Standalone controls

### Thermostat T-EC - EC fan motor

Thermostat accessory 35169884-001

Relay card REL04 accessory  
35169885-001

Thermostat T-EC + relay card REL04  
accessory 35169886-001

The thermostat is connected to a unit controller REL04 with 2 wires. One thermostat can be used for up to 16 units equipped with the REL04 control card creating a Master/Slave configuration with interconnection between all REL04 control cards.

#### Main characteristics

- On/Off button
- Manual 3 speed switch or automatic continuous speed control
- Manual winter / summer switch
- Temperature setting button
- Control up to 16 units in Master / Slave configuration



#### Operation

- 1 step cooling for water valve control On/Off
- 1 step heating for water valve or electric heater control On/Off
- Simultaneous control of the water valves / electric heater and fan operation based on the difference of the room temperature and set point
- It allows controlling the summer / winter cycle with a centralized and remote switch or with an automatic change over switch fitted on the water pipe
- With 4 pipe installation it can be configured as an automatic change over winter / summer with a neutral dead band of 2°C around set point
- Fan runs continuously and for auto fan mode the speed varies based on the difference of the room temperature and set point



## Standalone controls

---

### Thermostat U - AC fan motor

#### CONTROL WITH ELECTRONIC THERMOSTAT

(Accessory 35169835-001)



#### Main characteristics:

- Manual or automatic speed switch.
- Manual or automatic Summer/Winter switch.
- Electronic thermostat for fan control (on/off).
- Electronic thermostat for valve(s) control (on/off).
- It allows to control the minimum water temperature sensor (MWT).
- It allows to control the chilled water valve (on/off) and the electric resistance in the CWS-E version.
- It allows to control the fan and the heating electric resistance.
- It allows to control up to 10 units with the REL02 relay board.

**Note:** with 4 pipe installations and continuous chilled and hot water supply, it allows the automatic summer/winter change-over in accordance to the room temperature (-1,6°C = Winter, +1,6°C = Summer, Dead Zone 3,2°C).



## Group controls

---

### Group control via ModBus communication protocol through RS485 serial link

The MB controller is suitable for AC and EC fan motor technology. It can be connected to one T-MB thermostat or RT03 infrared remote controller field installed. One device can control up to 20 units in a Master/Slave configuration with ambient temperature controlled based on thermostat or on return air temperature sensor. When connected to the centralized time of day scheduler TODS controller, up to 60 units can operate together on the same agenda for 7 days each operating on individual set points and fan control. For rooms where set points and fan operation is left to occupants the MB controller can be connected to one T-MB thermostat or RT03 infrared remote control. In this case the latest command from any of the connected devices thermostat T-MB / RT03 or TODS is executed by the MB controller. If more than 60 units have to be installed in the building operating under the same TODS agenda, some terminal units serving the same zone in an open space shall be installed without control. It will be connected to a unit with MB controller using a relay card RELO3 for units with AC fan motor or in a wired daisy chain arrangement for EC fan motor but with a limitation to 10 units in this case. The same strategy shall be used for zones where several units shall be installed so only one user interface T-MB or RT03 is required per zone for several units.

### System configuration

More over, the TODS centralized controller is capable to pilot up to 8 external devices like a chiller or an air handler using the external control card ECC. Each external device can provide the state of operation to the TODS controller to provide a diagnosis about the installation. Such the MB control using ModBus communication protocol is a powerful device than can operate a small building in a system configuration.

### Configuration and commissioning

The MB controllers are factory configured for the application. The terminal address and operating parameters are configured on the controller using dip switches which make the commissioning accessible to anyone reading simple instructions in the installation manual.



# Group controls

## T-MB thermostat

(Accessory 35169876-001)

The T-MB thermostat and the Modbus controller suit all types of system applications.

- 2 or 4 pipe
- 2-pipe with auto changeover
- 2-step heating with electric heater
- Fan operation with continuous or alternate with destratification.

It is connected to the factory-mounted unit controller MB and configured for the customer's requirements. The MB controller can be connected in a Master/Slave configuration with up to 20 units.

External devices: window contact, cold air draft protection with T3 sensor.

The T-MB wall-mounted thermostat is used with the Modbus controller fitted on the cassette. The Modbus controller is factory-configured for the customer's application. The T-MB thermostat is configured by default to control air ambient temperature based on the temperature sensor of the thermostat. In the case that return air temperature is used, it can be configured using the dipswitch 2 in position ON during installation.

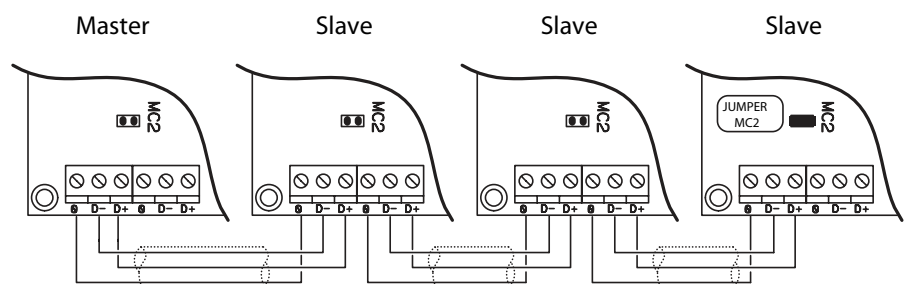
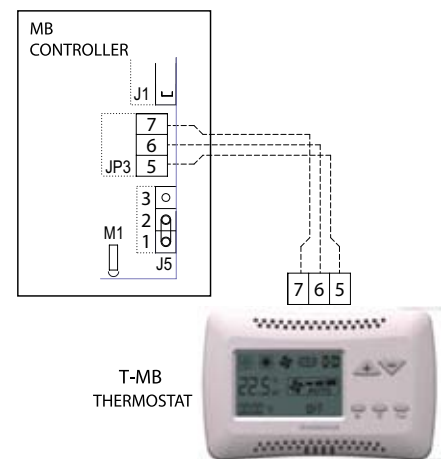

TYPE BELDEN 9841, RS-485, 1x2x24 AWG SFTP, 120 Ohm



## Group controls

### RT03 remote control (accessory 35169889-001)

The RT03 is a remote controller handset that can be fitted with the MB electronic board as an accessory. There is a remote sensor to install on site and some configuration dipswitches to turn on. It is possible to connect up to 20 units with a serial link RS485 for a master/slave configuration. It is recommended to install the infra-red receiver on the master unit.

*Figure 3 - Infra-red remote control/field-installed receiver/installation in a ceiling tile*

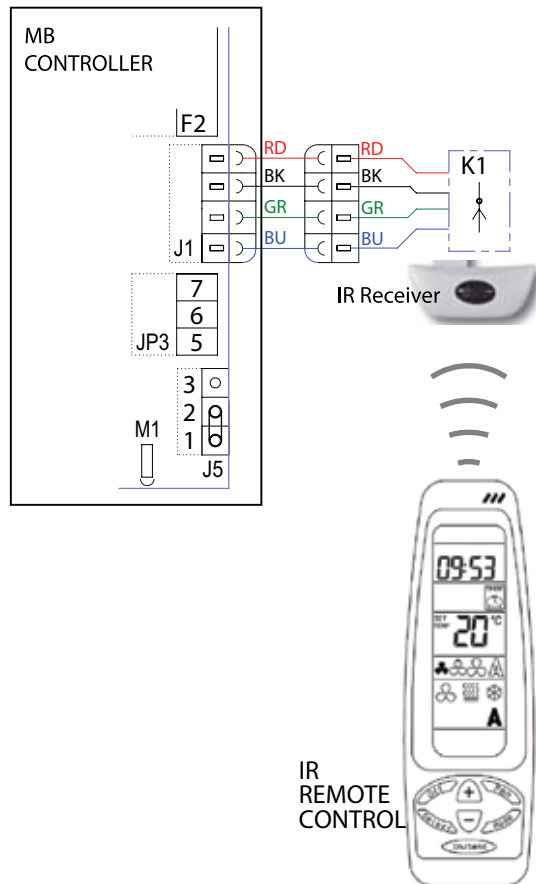

### Note

For more details, please refer to the infra-red remote control manual.

#### Control operations

- Temperature set.
- Fan speed switch with possible automatic speed selection.
- 24 hours on/off program.
- on/off cooling valve control.
- on/off heating valve control.
- Control of the valves only or of the valves and the fan together.
- Valve control of 2 or 4 pipe systems with winter/summer switch on the infra-red control.
- Valve control of 4 pipe systems with automatic heating/cooling mode selection with 2°C dead zone.
- Activating the COE sensor connected to the T2 contact of the board (non active in the standard configuration), it works like a minimum water temperature sensor: fitted between the coil fins it stops the fan when the water temperature is lower than 38°C and it starts the fan when the water temperature reaches 42°C



# Group controls

## Main functions of the remote control

Figure 4 - Remote control display

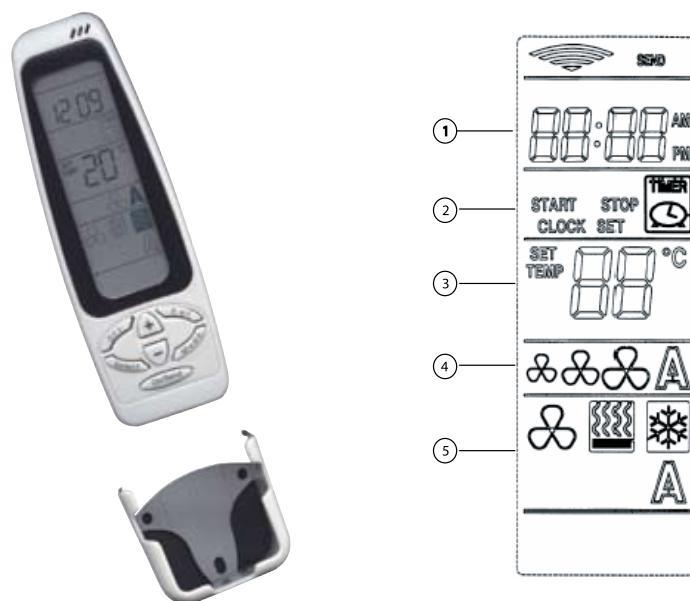

1. Clock : 24 hours
2. Timer : the program switches the device on and off
3. Displays the temperature setpoint
4. Fan speed setting: 3 speed plus automatic selection
5. Operating mode: heat, cool, fan only plus and automatic mode selection.

### Timer function:

Used to start or stop the unit over a 12 hour period.

### Set display:

Used to display the temperature set point.

### Fan speed setting:

Used to select the 3 operating speeds of the fan, or alternatively select automatic control. In the latter case, the fan speed will change automatically based on the ambient temperature reading and the set point. The temperature difference to switch from one speed to the next is 0.7 °K.

### Operating mode:

Used to select the desired operating mode, that is, fan only, cooling, heating or automatic mode selection.

Automatic selection allows, in 4 pipe systems, the unit to switch automatically from heating to cooling and vice-versa based on the ambient temperature reading and the set point, with a dead zone of 2°K inside which the unit remains in fan only mode.



# Building Management Controls

## Intelligent LonTalk® ZN523 control for AC fan motor

The Tracer® ZN unit controller is a micro-processor based direct digital controller that is dedicated to the control and the optimization of the units. It is designed to provide improved comfort with minimum energy consumption through the use of custom proportional integral derivative (PID) control algorithms as well as intelligent fan speed and set point control strategies. It is factory installed, pre-commissioned and tested, resulting in a highly integrated product, reduced installation and commissioning time.

The following configurations are supported by the controller:

- 2-pipe cooling;
- 2-pipe cooling + electric heater;
- 2-pipe changeover (manual or automatic);
- 2-pipe changeover + electric heater;
- 4-pipe.

Figure 5 - LonTalk® ZN523 control



The intelligent control offers the following benefits:

- Intelligent management of valve position and fan speeds. Valve is fully open before changing the fan speed (acoustic comfort optimization).
- Control algorithms based on ambient and discharge air temperatures.
- Discharge air temperature (low and high limit control).
- Automatic intelligent changeover based on ambient air - entering water temperatures differential (+/-%2.5K).
- Automatic intelligent changeover with sampling function for 2-way valves use.
- Filter timer for preventive maintenance
- Adjustable local set point max - min limits.
- Built-in electrical protection.
- 2 operating modes in stand-alone application: comfort and reduce.
- After a power up in the building, units automatically staggered from 5 to 32 seconds.
- Built-in adjustable timed override function.
- Built-in condensate overflow protection.
- Built-in output test capability.
- Built-in diagnostic indicator.

Figure 6 - Normal operating mode

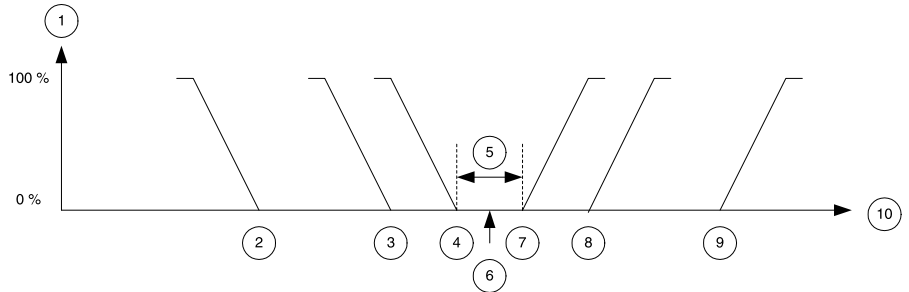

1. Control output
2. Unoccupied heating setpoint
3. Occupied standby heating setpoint
4. Occupied heating setpoint
5. Dead band
6. Local setpoint
7. Occupied cooling setpoint
8. Occupied standby cooling setpoint
9. Unoccupied cooling setpoint
10. Temperature

For more details about the LonTalk® ZN control, please refer to the controller's manual.

# Accessories

---

## Accessories

### Fresh air spigot

#### Accessory 35169832-001

2 fresh air spigots with diameter 99 mm and 124 mm can be field installed on the opposite side of the control box on the return air side of the unit between the filter and the fan assembly. They are suitable for use with constant volume damper that can be fitted directly inside the spigot. It is necessary to remove the precut circular sheet metal on site and the spigot can be directly screwed to the unit using the free holes for this. The sheet metal screw size 4 mm shall be used.

### Constant volume damper

#### Accessory 35169823-001 (30m<sup>3</sup>/h)

#### 35169824-001 (45m<sup>3</sup>/h)

#### 3516-9825-001 (Adjustable 70-180m<sup>3</sup>/h)

The constant volume damper accurately controls the air volume within a pressure range of 50 to 200 Pa. Two fixed models for 30 and 45 m<sup>3</sup>/h for spigot diameter 99 mm are available. One adjustable fresh air volume model from 70 to 180 m<sup>3</sup>/h is available for spigot diameter 124 mm.

It shall be field installed.

### Auxiliary drain pan

#### Accessory 35169813-001 (right hand)

#### 35169812-001 (left hand)

There is one model for left hand and one for right hand unit configurations. It shall be installed below the water valve package on the opposite side of the control box. It is made of plastic material ABS UL 94-HB

### Condensate pump

#### Accessory 35169826-001

A condensate pump kit is available for field installation, it has the same performances than the factory-mounted version, see page 31.

### Water valve kits

Several water valves kits are available for field installation. They are the same as the factory-mounted ones. The kit includes the valve, the actuator and the copper piping for connection to valve body. Leak tightness is ensured with synthetic flat joints delivered with the kit. The diameter is DN 15 for size 16 and 26 and DN20 for size 36 for the cooling coil, and DN15 for all unit sizes for the heating coil.

They are available in 2 and 3-way models and for thermal hot wax actuator only.

See table page 22 for accessories.

### Copper connection

#### Accessory 35169827-001 (size 16 & 26)

#### 35169828-001 (size 36)

This kit is used for field-installed water valves in order to have the inlet and outlet connections distant from 40 mm suitable for any water valve type. It is delivered with synthetic flat joints.

### Filter

#### Accessory 35169814-001 (G0 size 16)

#### 35169815-001 (G0 size 26)

#### 35169816-001 (G0 size 36)

#### 35169817-001 (EU3 size 16)

#### 35169818-001 (EU3 size 26)

#### 35169819-001 (EU3 size 36)

EU3 spare filters are available for field installation, made of 8 mm synthetic thick material class M1.

## Accessories

### Control accessories

#### T3 MWT Minimum Water temperature sensor (accessory 35169838-001)

Suitable for wall thermostats R, T, and U only (not for infra-red remote control). To be fitted between the coil fins, it is measuring the water temperature in the coil.

In heating mode, it stops the fan when the water temperature is lower than 38°C and it starts the fan when it is higher than 42°C.

It is a standard feature on unit equipped with the group control.

#### T2 Automatic change over pipe thermostat (accessory 35169820-001)

Suitable for wall thermostats N, P, R, T and U only (not for infra-red remote control). Automatic summer/winter switch to be installed in contact with the entering water circuit and before the control valve (for 2-pipe installations only). The cooling mode is allowed if the water temperature is below 15°C and the heating mode is allowed if the water temperature is above 25°C.

#### T2 Automatic change over pipe thermostat (accessory 35169839-001)

Suitable for MB controller with T-MB thermostat or RT03 remote control.



Thermostat T-EC

#### T-MB control (wall-mounted control) (accessory 35169876-001)



The T-MB is a wall-mounted control that can be connected to cassettes fitted with the IR electronic board. The T-MB control features the following functions:

- Switch the unit on and off.
- Temperature set.
- Fan speed switch with possible automatic speed selection.
- Setting the operating mode.
- 7-day time scheduler

It can be installed one control per cassette, or one control for up to 20 cassettes (master/slave configuration) through RS485 serial link.

It is recommended to install the wall-mounted control on the master unit.

See Installation-Operation-Maintenance manual for wiring information.

#### Thermostat T-EC (accessory 35169884-001)

Thermostat for CFAE for installation on the job site. It can control up to 16 units.

#### Electronic control card (accessory 35169885-001)

For installation on the job site. One card per unit is required. To be used with thermostat T-EC.

#### Kit: Thermostat T-EC + electronic card (accessory 35169886-001)

For standalone installations.

# Accessories

## REL03 Relay card for master/slave configuration - AC fan motor (accessory 35169875-001)

Fitted in the control panel of the master and slave cassettes, this enables up to eight units to be controlled by the signal from a single remote control unit.

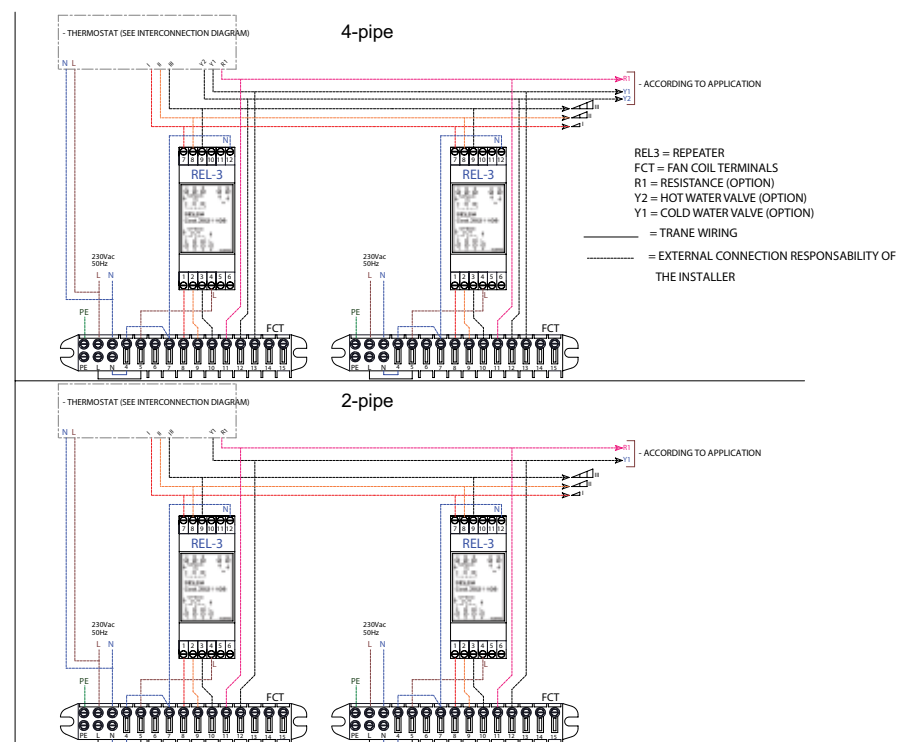

## Accessories

### REL02 for U-type thermostat - AC fan motor (accessory 35169836-001)

It allows to control up to 10 units with RS485 serial link.

Figure 8 - REL02 connection with 1 valve

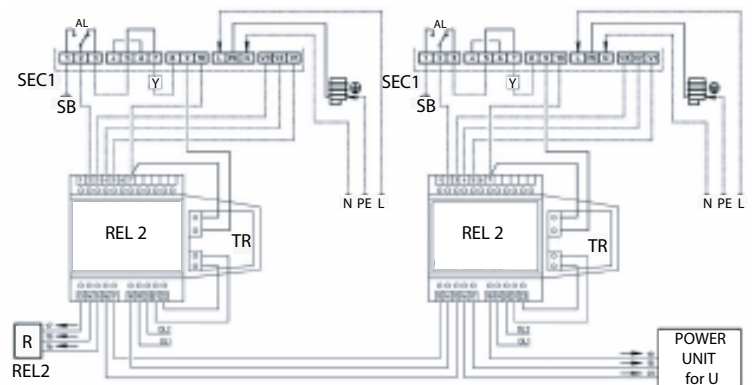

### REL04 for T-EC thermostat - EC fan motor Accessory 35169885-001

It allows control of up to 16 units with RS485 serial link.





## Accessories

---



### **TODS (Time Of Day Scheduler) Accessory 35169878-001**

Designed to control up to 60 units in 2 zones within 7 days of operation plus with the external control board it can start and stop 8 other equipment's as:

- Chiller for cooling and heating water supply
- Boiler for hot water supply
- Air handler unit for fresh air supply
- Lamps
- Other devices

Each unit connected to the TODS will need to be identified with an alias number from 1 to 60 configured by dip switch on the MB unit control board. Each unit will dialogue with the TODS through the RS485 serial link using ModBus communication protocol. Each unit is controlled individually or all at a time per zone and from the TODS the following actions can be taken:

- View the unit operation mode as heating or cooling, fan operation, the ambient temperature
- Run the air-conditioning in comfort or economy mode or winter freeze control when off
- Turn On/Off each unit individually or all together
- Modify the operation parameters and temperature control of each individual unit or all units together
- Operate the Air-conditioning installation within 4 schedule range per day each with its own temperature setting over 2 zones maximum
- Run the system in Economy or Off mode during holidays. The number of days off needs to be entered the day before the start of the holiday period using the "Menu" button.

Note: the length of the RS485 cable cannot exceed 700 to 800 meters depending upon the cable quality and electromagnetic environment



## Accessories

---



### **ECC System control board Accessory 35169887-001**

The ECC control board is designed to control up to 8 external equipment within the association of the weekly scheduler TODS such as:

- Chillers
- Cooling and heating mode for the chillers
- Air handlers
- Dampers
- Lamps
- Extractor fans

It has 8 digital inputs that can be associated with any of the other 8 outputs.

The utilization of the TODS with the external control board ECC can really run efficiently the air-conditioning of any building configuration to reduce the cost of ownership.



## Notes

---



Trane optimizes the performance of homes and buildings around the world. A business of Ingersoll Rand, the leader in creating and sustaining safe, comfortable and energy efficient environments, Trane offers a broad portfolio of advanced controls and HVAC systems, comprehensive building services, and parts. For more information, visit [www.Trane.com](http://www.Trane.com).

Trane has a policy of continuous product and product data improvement and reserves the right to change design and specifications without notice.