



# *Installation and Operation HumidiPack<sup>®</sup>, HumidiPack CF, and HumidiPackPlus<sup>™</sup>*

Complete Packaged Humidifier Systems



---

## Table of Contents

Preliminary Procedures .....	2
Do's & Don'ts of Location and Installation .....	3
Installation .....	4
Typical Duct Installations .....	5
Installation Concepts .....	6
Auxiliary Controls .....	9
Troubleshooting Guide .....	11
Limited Warranty and Remedy .....	12

---

## Preliminary Procedures

---

These instructions cover the installation of the HumidiPack® and HumidiPackPlus with the Armstrong ACV Control Valve (models listed below). The HumidiPack and HumidiPackPlus represent complete packaged humidification systems when used in conjunction with existing boiler steam. HumidiPack may also be used for distribution of steam generated by electric or steam-to-steam humidifiers (steam generating). In these instances, no strainer, control valve, or steam traps are supplied. When used with boiler steam, the systems come with the following equipment:

### HumidiPack Contents:

- **HumidiPack Panel**
- **Armstrong Inverted Bucket Steam Trap**  
(to be used to drip steam supply to control valve)
- **Armstrong ACV Control Valve**
- **Armstrong In-Line Y Strainer**  
(to be used prior to the control valve)
- **Armstrong Float & Thermostatic Steam Trap**  
(for condensate drainage of HumidiPack header)  
(two traps are needed for HumidiPack CF)

### HumidiPackPlus Contents:

- **HumidiPackPlus Panel**
- **Armstrong Inverted Bucket Steam Trap**  
(to be used to drip steam supply to control valve)
- **Armstrong ACV Control Valve**
- **Armstrong In-Line Y Strainer**  
(to be used prior to the control valve)
- **Two Armstrong Float & Thermostatic Steam Traps** (one for header drainage, one for active tube jacket drainage)

### Step 1: Check Shipment Against Packing List.

All components are listed on the packing slip. Report any shortages **immediately**. If the HumidiPack or accessories have been damaged in transit, notify us and file claim with the transportation company.

Armstrong ACV Control Valves*	
Model Size	Available Pneumatic Operators
ACV-2	Armstrong C-1801
ACV-3	Honeywell MP-953D
ACV-4	Honeywell MP-953F w/Pilot
ACV-6	Positioner
Model Size	Available Electric Operators
ACV-2	Honeywell M9182A
ACV-3	Belimo
ACV-4	AF24SR or NVF24
ACV-6	

\*Some larger size HumidiPacks may use 2" or 2-1/2" Honeywell control valves.

If your order covers more than one package, segregate each complete assembly. Equipment tagging will be the same as shown on the packing list. Model, Serial Number, Steam Pressure and Orifice Size are on the metal plate on the control valve body.

### Step 2: Check Local Codes.

The Armstrong HumidiPack should be installed in accordance with all applicable building, plumbing, and electrical codes.

### Step 3: Find HumidiPack Panel Location.

Locate all HumidiPack equipment according to the engineer's layout or as indicated by your Armstrong Representative. If you must locate the HumidiPack/HumidiPackPlus yourself, be sure to read and observe the "Do's and Don'ts" to follow.

## Do's & Don'ts of Location and Installation

---

All recommendations for the application of the Armstrong HumidiPack and HumidiPackPlus are based on tests and field experience. However, they are based on duct air velocities and temperatures that are most commonly encountered, and the recommendations may have to be modified when velocities are very high and/or temperatures unusually low. We also reserve the right to modify recommendations without notice if subsequent tests or experience indicate that a change should be made. For these reasons, we urge you to check all applications with your Armstrong Representative before installation. (Illustrations applicable to both HumidiPack and HumidiPackPlus.) See Figures 3-1 through 3-7.

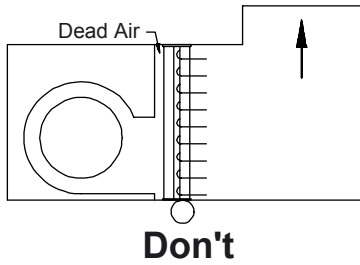

**Figure 3-1.** The HumidiPack must have airflow across the entire cross-section. Avoid fan discharges without gradually transitioning the duct to the HumidiPack.

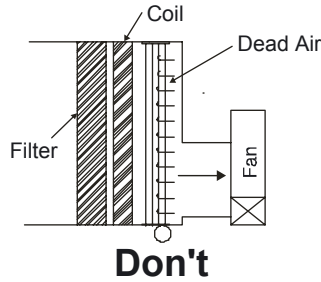

**Figure 3-2.** The HumidiPack cannot have dead air space off the discharge side. When discharging into a fan intake plenum, allow for vapor trail length then gradually transition the duct.

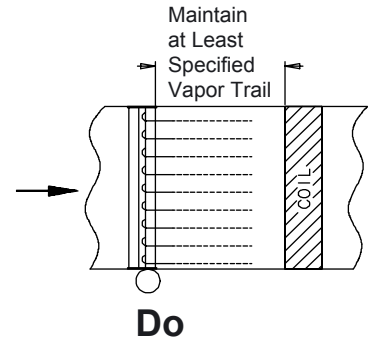

**Figure 3-3.** Coils, duct transitions and other obstructions must be kept at least the specified vapor trail length downstream from the HumidiPack. This does not apply to high efficiency filters. Consult factory on these applications.

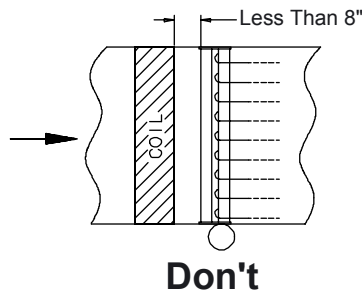

**Figure 3-4.** Eight inch clearance (Min.) should be maintained on discharge side of coils.

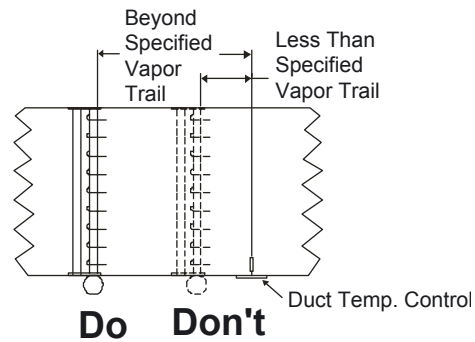

**Figure 3-5.** If temperature controlling devices must be placed directly downstream from the HumidiPack, all visible vapor must be absorbed. This may be a longer distance than just the specified vapor trail. Consult factory if questionable applications arise.

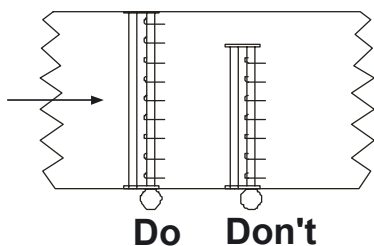

**Figure 3-6.** All airflow must be directed through HumidiPack. If HumidiPack is smaller than the duct cross-section, HumidiPack should be positioned in center of duct and all open area should be blocked off. This is an exception for some "all active" unit applications.

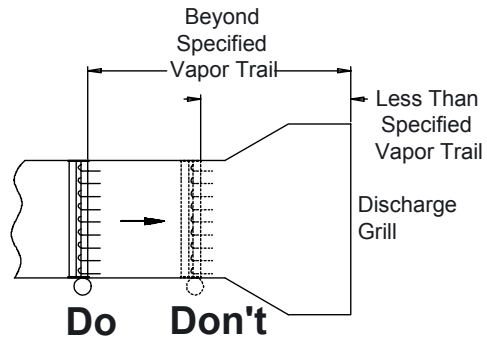

**Figure 3-7.** When installing the HumidiPack directly upstream from a discharge grill, the minimum distance shall be the specified vapor trail. It should be noted that visible wisps of vapor can still be seen even though the length is beyond the vapor trail. This vapor will not condense on the grill, but may be seen in the room space.



## Typical HumidiPack® Duct Installations

(HumidiPackPlus orientation is similar)

(HumidiPackPlus orientation is similar)

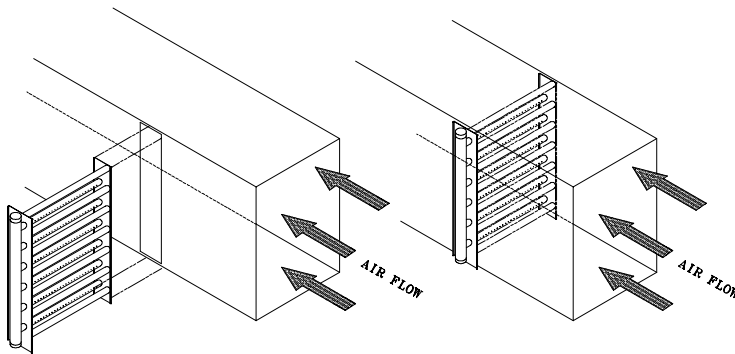

**Figure 5-1**  
**Horizontal Unit Right to Left Flow**  
(Left Hand Header)

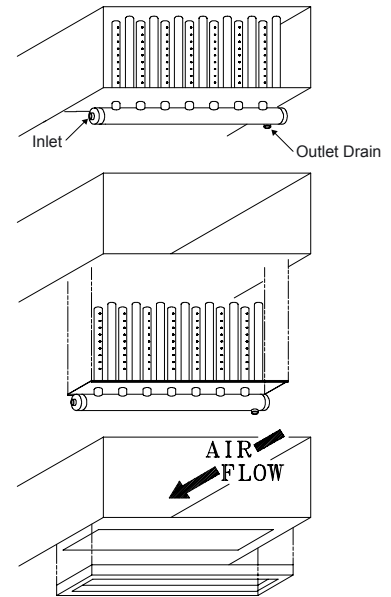

**Figure 5-2**  
**Vertical Unit Left Handed Steam Inlet**

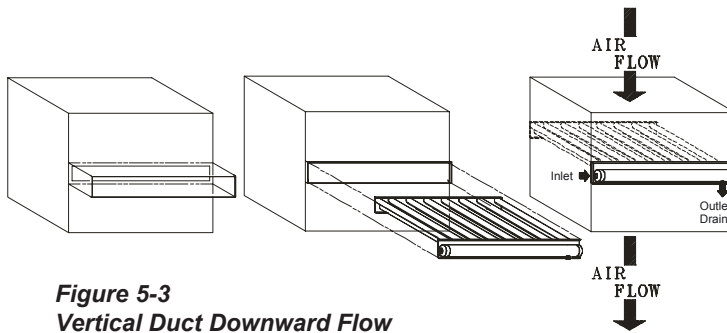

**Figure 5-3**  
**Vertical Duct Downward Flow**  
(Left Hand Inlet)

## Installation Concepts

### Condensate Drainage Options

Condensate discharged from the HumidiPack or HumidiPackPlus separator/header is at essentially atmospheric pressure. Thus the condensate must be discharged to a drain or pumped. On many applications, an attempt to lift condensate even a few inches will lead to potential flooding or spitting problems from the multiple tube bank. For HumidiPackPlus units having a header drain connection and active tube jacket drain connection, a separate F&T steam trap must be used for each. Avoid master trapping the two connections to one steam trap. If traps discharge into a common return, install check valves (low opening pressure) on the outlet of each steam trap.

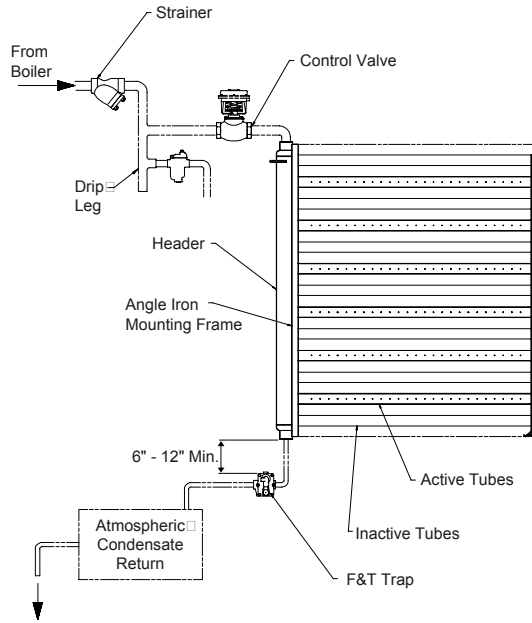

Figure 6-1. Header drain trap discharging to pumped return (HumidiPack shown)

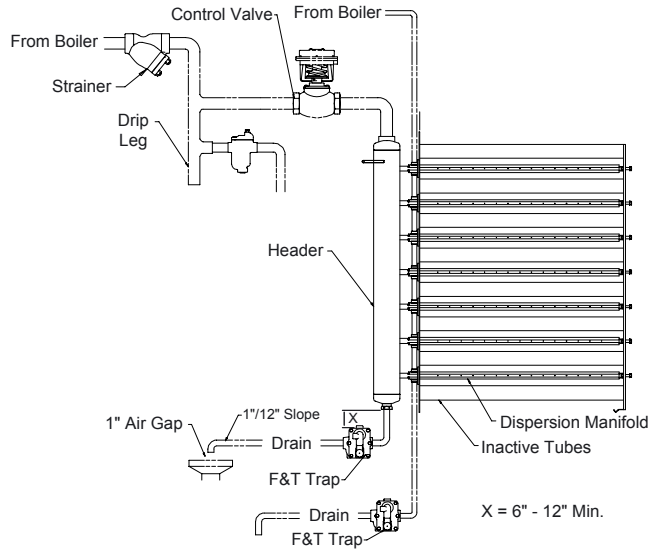

Figure 6-2. Drain traps discharging to floor drain. (HumidiPackPlus shown)

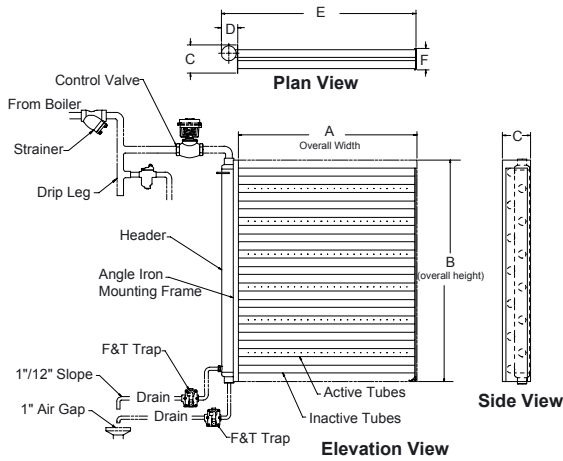

Figure 6-3. HumidiPack CF. Drain traps discharging to floor drain.

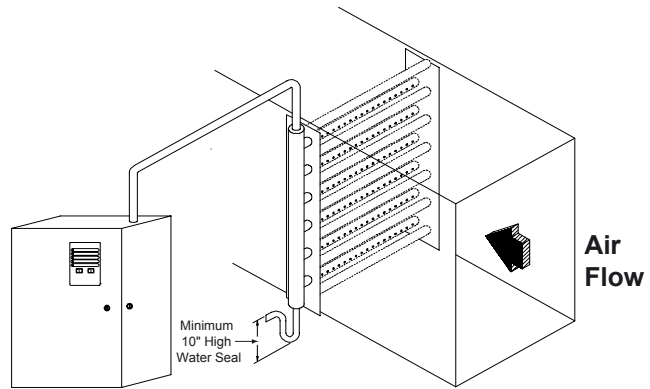

Figure 6-4. Condensate drained through piping loop seal. Make sure outlet of loop seal is below bottom of HumidiPack header.

**NOTE:** When installing HumidiPack for use with an electric or steam-to-steam humidifier, minimize the length of piping run from the humidifier to Humidi-Pack. Piping should not extend longer than 20 feet and should be a generous size (at least 2"). Consult factory if longer piping is necessary.

Slope piping back toward humidifier or toward a drainage point. Pipe a loop trap to an atmospheric drain at any low points in piping run. Install, at minimum, a 10" loop seal from the HumidiPack header drain connection.

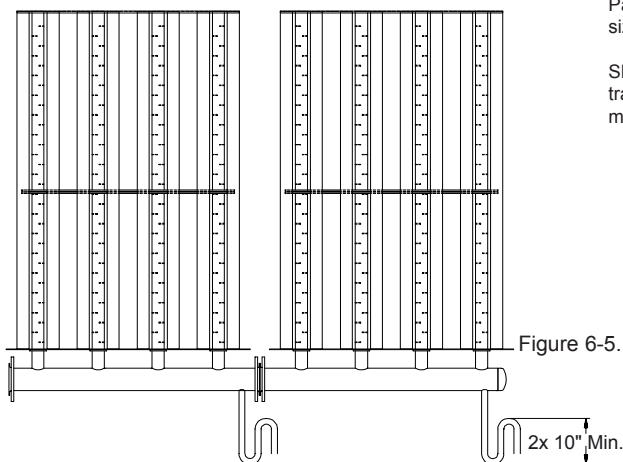

Figure 6-5. Dual Panel Flanged HumidiPack System. Both "P" traps drained to atmospheric drain.

## Step 5: Supply Steam Piping

Supplying quality steam (not wet) to the HumidiPack/HumidiPackPlus is an important component for proper operation. Care must be taken that the main supply header is dripped sufficiently as well as the runout piping to the Armstrong ACV Control Valve and HumidiPack/HumidiPackPlus header. The entire system must be designed and hooked up to prevent accumulation of condensate at any point. The following recommendations will help to ensure this.

Use drip legs and traps at all low spots or natural drainage points such as: Ahead of risers; End of mains; Ahead of expansion joints or bends; Ahead of valves or regulators. Install drip legs and drain traps even where there are no natural drainage points (See Figures 7-1 thru 7-5).

On a supervised warm-up, make drip leg length at least  $1\frac{1}{2}$  times the diameter of the main, but never less than 10". Make drip legs on automatic warm-ups a minimum of 28" in length. For both methods, it is a good practice to use a drip leg the same diameter as the main up to 4" pipe size and at least  $\frac{1}{2}$  of the diameter of the main above that, but never less than 4". See Table 7-1.

**Table 7-1. Recommended Steam Main and Branch Line Drip Leg Sizing**

M Steam Main Size (in)	D Drip Leg Diameter (in)	H Drip Leg Length Minimum	
		Supervised Warm-Up (in)	Automatic Warm-Up (in)
1/2	1/2	10	28
3/4	3/4	10	28
<b>1</b>	<b>1</b>	<b>10</b>	<b>28</b>
2	2	10	28
3	3	10	28
<b>4</b>	<b>4</b>	<b>10</b>	<b>28</b>
6	4	10	28
8	4	12	28
<b>10</b>	<b>6</b>	<b>15</b>	<b>28</b>
12	6	18	28
14	8	21	28
<b>16</b>	<b>8</b>	<b>24</b>	<b>28</b>
18	10	27	28
20	10	30	30
<b>24</b>	<b>12</b>	<b>36</b>	<b>36</b>

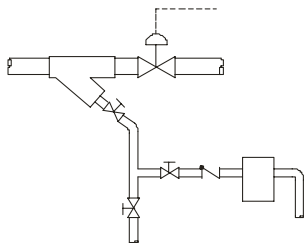

Figure 7-1. Trap draining strainer ahead of PRV.

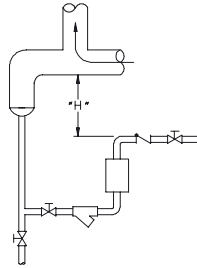

Figure 7-2. Trap draining drip leg at riser. Distance "H" in inches  $\div$  28 = psi static head for forcing water through the trap.

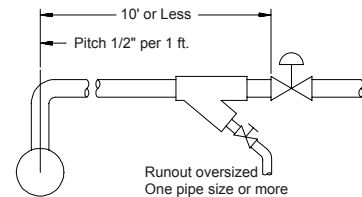

Figure 7-3. Piping for runout less than 10 ft. No trap required unless pitch back to supply header is less than  $\frac{1}{2}$ " per ft.

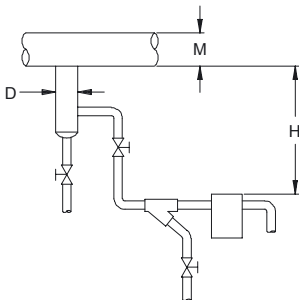

Figure 7-4. Trap draining drip leg on main.

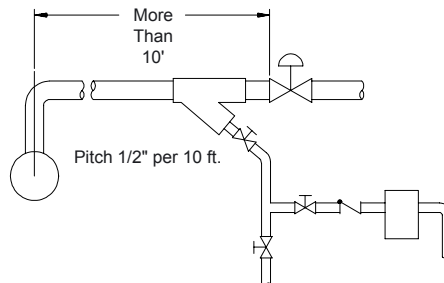

Figure 7-5. Piping for runout greater than 10'. Drip leg and trap required ahead of control valve. Strainer ahead of control valve can serve as drip leg if blowdown connection runs to an inverted bucket trap. This will also minimize the strainer cleaning problem. Trap should be equipped with an internal check valve or swing check installed ahead of the trap.

Shown below are typical configurations depicting proper piping practices. Do not use smaller pipe sizes than what the connections are on the supplied control valve. Take steam supply from the top of supply main **never** from the side or bottom. See Steam Pipe Capacities tables on Page 12.

**Expansion and Contraction.** With average length of supply line, the dimension change from hot to cold should not exceed 2". Provide piping with (3) 90° elbows to obtain swing to take care of expansion and contraction.

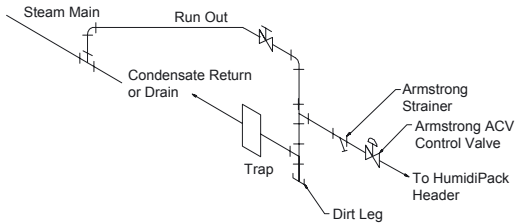

Figure 8-1. Typical runout less than 30 feet long.

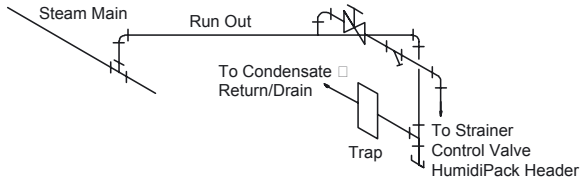

Figure 8-2. Typical long runout of 30 feet or more.

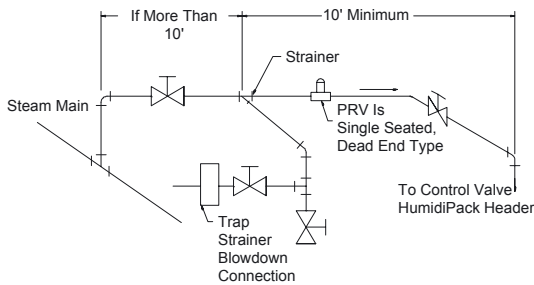

Figure 8-3. If the supply steam to the control valve exceeds the control valve pressure rating, an Armstrong pressure reducing valve may need to be installed after the Y strainer as shown.

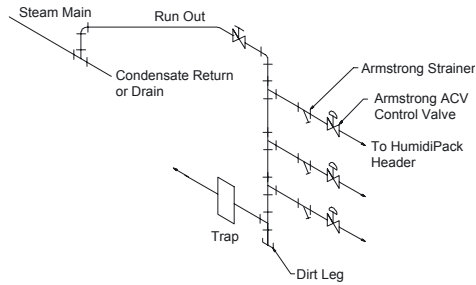

Figure 8-4. Piping when more than one Humidi-Pack or HumidiPackPlus is fed from the same steam runout.

**Control Valve.** The Armstrong control valve is installed in the steam supply line after the Y strainer and supplies steam to the header of the HumidiPack/HumidiPackPlus panel. The steam supply connection on the top of the HumidiPack/HumidiPackPlus header is either 1" NPT or 2" NPT. The control valve connection size may be different. In these cases, reduce from the 2" connection on the HumidiPack/HumidiPackPlus header down to the Armstrong control valve size by bushing the 2" HumidiPack/HumidiPackPlus connection.

Piping of air supply to pneumatic control valves are discussed in Figures 9-1, 9-2 and 9-3 while wiring for electric control valves is discussed in Figure 10-1. For more installation information of Armstrong Control Valves, see Installation Bulletin IB-58.

## Step 6: Install Armstrong Float & Thermostatic Steam Trap(s)

### a) HumidiPack

The connection on the bottom of the HumidiPack header is for condensate drainage. The supplied Armstrong Float & Thermostatic steam trap should be piped from this connection as illustrated in Figure 4-1. Make sure a distance of 6" - 12" is maintained between the top of the F&T trap and the bottom of the HumidiPack header. A second connection is used for HumidiPack CF and the same guidelines should be followed.

### b) HumidiPackPlus

The connection on the bottom of the HumidiPackPlus header is for condensate drainage and one of the supplied Armstrong Float & Thermostatic steam traps should be installed in this location as shown in Figure 6-2. Make sure a distance of 6" - 12" is maintained between the top of the F&T trap and the bottom of the HumidiPackPlus header. The second supplied Armstrong Float & Thermostatic steam trap should be installed at the active tube jacketing drain connection as illustrated in Figure 6-2.

*The discharge pressure from the steam traps is at essentially atmospheric pressure. Thus, the condensate must be discharged to a suitable drain, or a condensate pump. It cannot be connected to an overhead return without pumping.*

**NOTE:** The Armstrong CS Series, EHU-600 Series, and EHU-700 Series Humidifiers, along with the Armstrong HC-4000 Series HumidiClean and GFH Series Gas Fired HumidiClean can be used in conjunction with the HumidiPack. The HumidiPack will not include the control valve, steam traps or strainer in these applications. (**HumidiPackPlus is not compatible with these humidifiers.**)

**Step 9A: Install Pneumatic Piping** in accordance with Figures 9-1, 9-2, or 9-3 or engineer's layout.

- a. **Control Air Supply.** Unless otherwise specified, air supply for Armstrong Humidifiers should be 20 psig maximum. This air must be clean and dry.
- b. **Air Piping.** ¼" plastic tubing or equivalent is recommended for all air connections.

**Step 10A. Install and Connect Humidity Controller** as specified by the design engineer in accordance with manufacturer's instructions. If location is not specified, it may be installed in the area controlled or in either the return air or exhaust air ducts.

## Auxiliary Controls

**High Limit Duct Humidity Controller.** A high limit humidistat is recommended downstream from the HumidiPack panel. The location of the high limit humidistat should be beyond the wettable vapor distance but not beyond any filters. The purpose of the high limit humidistat is to override the controlling humidistat. This high limit humidistat automatically prevents local saturation at the point of steam introduction. It also prevents overloading the duct with vapor in the event of failure of air conditioning system components, incorrect control settings, or tampering. See Figure 9-3.

**Interlocks for Shutdowns.** Humidifiers should be interlocked with fans for shutdown on power failure or other system trouble. Interlock should be such that control valve will bleed its control air to atmosphere on a system shutdown rather than be locked in its position at time of shutdown. See Figure 9-2.

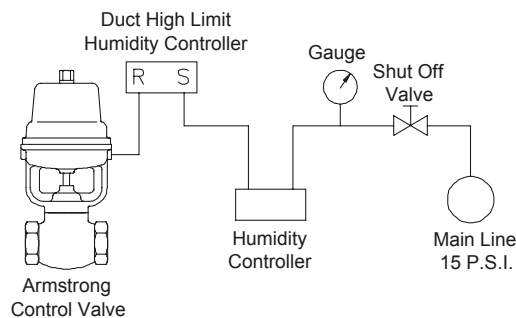

Figure 9-1. Standard compressed air hook-up for pneumatic control.

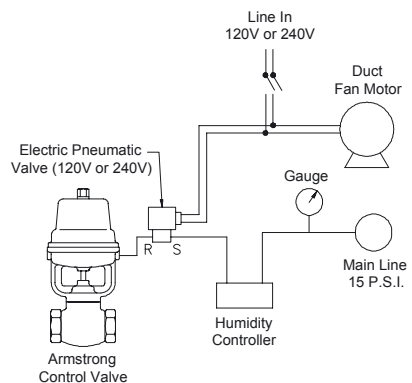

Figure 9-2. Compressed air hook-up for air operated humidifiers incorporating safety interlock for shut down in the event of power failure to fan.

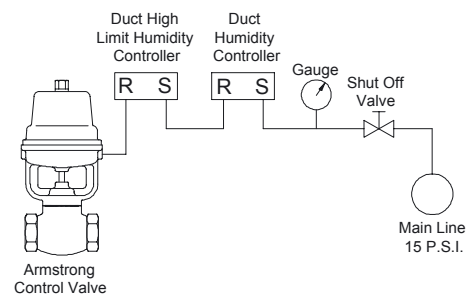
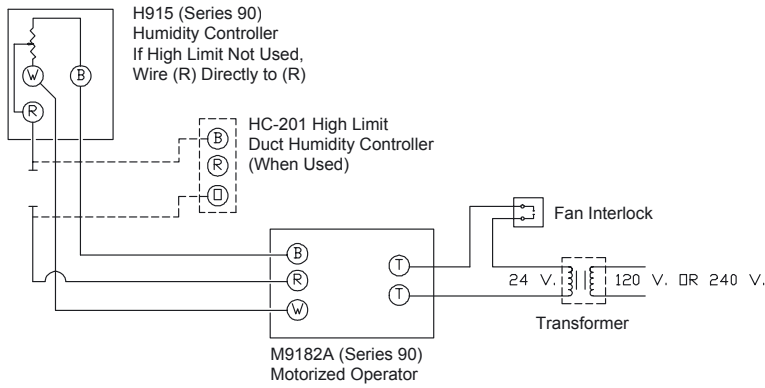

Figure 9-3. Compressed air hook-up for humidifiers utilizing two Armstrong Duct Humidity Controllers, one as the humidity controller, the other as a high limit controller.

Figure 10-1



**Step 9E (EM): Make Electrical**

**Connections** as recommended by the manufacturers of the operators and controls. Also, use Figures 10-1 through 10-3 as a guide. Be sure wiring is adequate for the requirements of the system. Check voltage ratings on operator nameplate.

“EM” Series electric motor operated humidifiers are furnished with a choice of Honeywell M9182A operators (24 watts at 24v, 60 Hz suitable for 120v or 240v with transformer), Belimo AF24SR or NVF24 electric motorized operators. These operators may be controlled by compatible humidity controllers or electronic humidity panels.

**For all EM operators mount operator so that the motor shaft is parallel to the floor (or horizontal).**

**Step 10E: Install and Wire Humidity Controller** as specified by the design engineer and in accordance with manufacturer's instructions. If location is not specified, the controller may be installed in area controlled or in either the return air or exhaust air ducts.

Figure 10-2

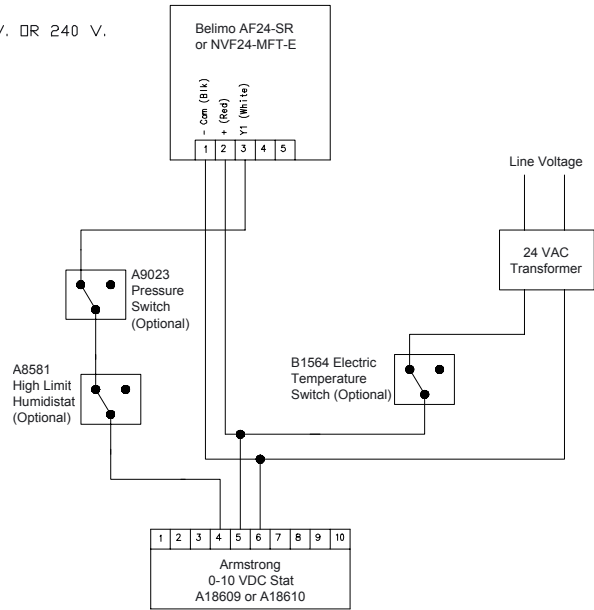
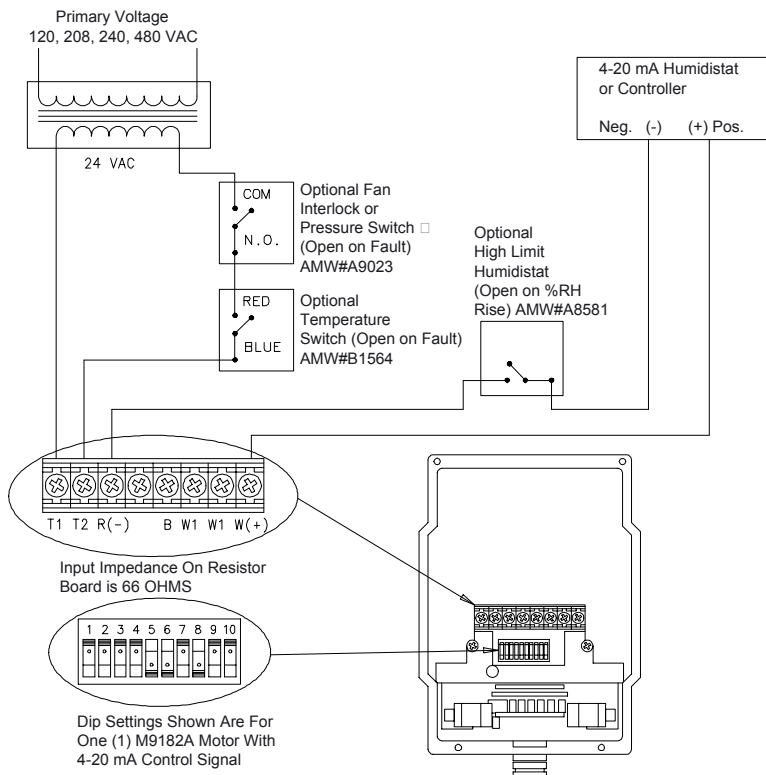

Figure 10-3



---

## Troubleshooting Guide

---

### I. HumidiPack/HumidiPackPlus will not discharge steam.

- A. Control System Fault
  - 1. Control valve operator-does the valve open and close as the control signal varies between 0% to 100%?
- B. Steam System Malfunction
  - 1. Strainer screen before control valve is plugged.
  - 2. Pressure reducing valve malfunction.

### II. HumidiPack/HumidiPackPlus discharges continuously even though humidity has exceeded desired level.

- A. Humidity controller or pneumatic operator out of calibration.
- B. Control valve malfunction.
  - 1. Valve stem on control valve "frozen" to stem seal due to unusual chemical or corrosive conditions in steam system.
  - 2. Operator spring on pneumatic control valve broken.
  - 3. Dirt or scale between valve and seat in control valve - blow down and clean strainer.

### III. Low Steam Output

- A. Control system
  - 1. Humidity controller or pneumatic operator not calibrated or malfunctioning.
  - 2. Control valve faulty.
- B. Steam system
  - 1. Piping not sized correctly.

### IV. HumidiPack/HumidiPackPlus "Spitting"

- A. Lift or back pressure after float & thermostatic steam trap(s) is too great for steam supply pressure resulting in flooded HumidiPack panel.
- B. Supply steam not properly dripped.
- C. HumidiPackPlus ONLY: Jacketing supply steam to the active tubes may be isolated or off.
- D. The steam trap draining HumidiPack/HumidiPackPlus header has failed closed.
- E. HumidiPackPlus ONLY: The steam trap draining the active tube jackets has failed closed.
- F. Tubes on the panel are sloped away from instead of towards the header.
- G. Not enough "head" distance in between the bottom of the HumidiPack/HumidiPackPlus header and top of F&T drip traps.
- H. Steam trap draining HumidiPack/HumidiPackPlus header is not isolated from a common return line (check valves not installed after trap.)
- I. Verify sufficient jacketing pressure is available for HumidiPackPlus units. Contact factory for acceptable guidelines.

## Steam Pipe Capacities

For computing ability of piping to deliver an adequate supply of steam to humidifier. Capacities shown are in pounds per hour.

**Table 1 Steam Pipe Capacity at 5 psi**

Pipe Size (in)	Pressure Drop, psi per 100 ft. of pipe length					
	1/8	1/4	1/2	3/4	1	--
1	24	31	44	54	62	--
1-1/4	52	68	97	120	140	--
1-1/2	81	100	150	180	210	--
2	160	210	300	370	430	--
2-1/2	270	350	500	610	710	--

**Table 2 Steam Pipe Capacity at 15 psi**

Pipe Size (in)	Pressure Drop, psi per 100 ft. of pipe length					
	1/8	1/4	1/2	3/4	1	2
1	27	38	53	65	76	110
1-1/4	59	83	120	140	160	230
1-1/2	91	130	180	220	260	360
2	180	260	370	450	520	740
2-1/2	300	430	600	740	860	1210

**Table 3 Steam Pipe Capacity at 25 psi**

Pipe Size (in)	Pressure Drop, psi per 100 ft. of pipe length					
	1/8	1/4	1/2	3/4	1	2
3/4	15	21	30	37	43	60
1	30	43	61	75	86	122
1-1/4	67	95	130	160	190	260
1-1/2	100	140	210	250	290	410
2	210	300	420	510	590	840
2-1/2	340	490	690	850	980	1380

**Table 4 Steam Pipe Capacity at 50 psi**

Pipe Size (in)	Pressure Drop, psi per 100 ft. of pipe length					
	1/4	1/2	3/4	1	2	5
3/4	27	38	47	54	76	120
1	54	77	94	110	150	240
1-1/4	120	170	210	240	340	530
1-1/2	180	260	320	370	520	830
2	370	530	650	750	1060	1680
2-1/2	620	870	1070	1240	1750	2760

## Limited Warranty and Remedy

Armstrong International, Inc. ("Armstrong") warrants to the original user of those products supplied by it and used in the service and in the manner for which they are intended, that such products shall be free from defects in material and workmanship for a period of one (1) year from the date of installation, but not longer than 15 months from the date of shipment from the factory, [unless a Special Warranty Period applies, as listed below]. This warranty does not extend to any product that has been subject to misuse, neglect or alteration after shipment from the Armstrong factory. Except as may be expressly provided in a written agreement between Armstrong and the user, which is signed by both parties, Armstrong **DOES NOT MAKE ANY OTHER REPRESENTATIONS OR WARRANTIES, EXPRESS OR IMPLIED, INCLUDING, BUT NOT LIMITED TO, ANY IMPLIED WARRANTY OF MERCHANTABILITY OR ANY IMPLIED WARRANTY OF FITNESS FOR A PARTICULAR PURPOSE.**

The sole and exclusive remedy with respect to the above limited warranty or with respect to any other claim relating to the products or to defects or any condition or use of the products supplied by Armstrong, however caused, and whether such claim is based upon warranty, contract, negligence, strict liability, or any other basis or theory, is limited to Armstrong's repair or replacement of the part or product, excluding any labor or any other cost to remove or install said part or product, or at Armstrong's option, to repayment of the purchase price. As a condition of enforcing any rights or remedies relating to Armstrong products, notice of any warranty or other claim relating to the products must be given in writing to Armstrong: (i) within 30 days of last day of the applicable warranty period, or (ii) within 30 days of the date of the manifestation of the condition or occurrence giving rise to the claim, whichever is earlier. **IN NO EVENT SHALL ARMSTRONG BE LIABLE FOR SPECIAL, DIRECT, INDIRECT, INCIDENTAL OR CONSEQUENTIAL DAMAGES, INCLUDING, BUT NOT LIMITED TO, LOSS OF USE OR PROFITS OR INTERRUPTION OF BUSINESS.** The Limited Warranty and Remedy terms herein apply notwithstanding any contrary terms in any purchase order or form submitted or issued by any user, purchaser, or third party and all such contrary terms shall be deemed rejected by Armstrong.

Special Warranty Periods are as follows:

**Series EHU-700 Electric Steam Humidifier, Series HC-4000 HumidiClean Humidifier and GFH Gas Fired Humidifier with Ionic Beds:**

Two (2) years after installation, but not longer than 27 months after shipment from Armstrong's factory.

© 2001 Armstrong International, Inc.

Designs, materials, and performance ratings are subject to change without notice.



Armstrong Hot Water Group

816 Maple Street, Three Rivers, Michigan 49093 - USA Phone: (269) 273-1415 Fax: (269) 273-9500

www.armstrong-intl.com

Printed in U.S.A.