



# Installation, Operation, and Maintenance

## Series R<sup>®</sup> Rotary Liquid Chillers Water-Cooled and Compressor-Chillers



RTWD 60  
RTWD 70  
RTWD 80

RTWD 90  
RTWD 100  
RTWD 110

RTWD 120  
RTWD 130  
RTWD 140

RTWD 150  
RTWD 160  
RTWD 180

RTWD 200  
RTWD 220  
RTWD 250

RTUD 80  
RTUD 90  
RTUD 100

RTUD 110  
RTUD 120  
RTUD 130

RTUD 150  
RTUD 160  
RTUD 180

RTUD 200  
RTUD 220  
RTUD 250

### **⚠ SAFETY WARNING**

Only qualified personnel should install and service the equipment. The installation, starting up, and servicing of heating, ventilating, and air-conditioning equipment can be hazardous and requires specific knowledge and training. Improperly installed, adjusted or altered equipment by an unqualified person could result in death or serious injury. When working on the equipment, observe all precautions in the literature and on the tags, stickers, and labels that are attached to the equipment.



# Warnings, Cautions and Notices

**Warnings, Cautions and Notices.** Note that warnings, cautions and notices appear at appropriate intervals throughout this manual. Warnings are provide to alert installing contractors to potential hazards that could result in death or personal injury. Cautions are designed to alert personnel to hazardous situations that could result in personal injury, while notices indicate a situation that could result in equipment or property-damage-only accidents.

Your personal safety and the proper operation of this machine depend upon the strict observance of these precautions.

Read this manual thoroughly before operating or servicing this unit.

---

**ATTENTION:** Warnings, Cautions and Notices appear at appropriate sections throughout this literature. Read these carefully:

**⚠ WARNING** Indicates a potentially hazardous situation which, if not avoided, could result in death or serious injury.

**⚠ CAUTION** Indicates a potentially hazardous situation which, if not avoided, could result in minor or moderate injury. It could also be used to alert against unsafe practices.

**NOTICE:** Indicates a situation that could result in equipment or property-damage only

---

## Important Environmental Concerns!

Scientific research has shown that certain man-made chemicals can affect the earth's naturally occurring stratospheric ozone layer when released to the atmosphere. In particular, several of the identified chemicals that may affect the ozone layer are refrigerants that contain Chlorine, Fluorine and Carbon (CFCs) and those containing Hydrogen, Chlorine, Fluorine and Carbon (HCFCs). Not all refrigerants containing these compounds have the same potential impact to the environment. Trane advocates the responsible handling of all refrigerants-including industry replacements for CFCs such as HCFCs and HFCs.

## Responsible Refrigerant Practices!

Trane believes that responsible refrigerant practices are important to the environment, our customers, and the air conditioning industry. All technicians who handle refrigerants must be certified. The Federal Clean Air Act (Section 608) sets forth the requirements for handling, reclaiming, recovering and recycling of certain refrigerants and the equipment that is used in these service procedures. In addition, some states or municipalities may have additional requirements that

must also be adhered to for responsible management of refrigerants. Know the applicable laws and follow them.

### ⚠ WARNING

#### Refrigerant under High Pressure!

System contains oil and refrigerant under high pressure. Recover refrigerant to relieve pressure before opening the system. See unit nameplate for refrigerant type. Do not use non-approved refrigerants, refrigerant substitutes, or refrigerant additives. Failure to recover refrigerant to relieve pressure or the use of non-approved refrigerants, refrigerant substitutes, or refrigerant additives could result in an explosion which could result in death or serious injury or equipment damage.

### ⚠ WARNING

#### Proper Field Wiring and Grounding Required!

All field wiring **MUST** be performed by qualified personnel. Improperly installed and grounded field wiring poses **FIRE** and **ELECTROCUTION** hazards. To avoid these hazards, you **MUST** follow requirements for field wiring installation and grounding as described in NEC and your local/state electrical codes. Failure to follow code could result in death or serious injury.

### ⚠ WARNING

#### Personal Protective Equipment (PPE) Required!

Installing/servicing this unit could result in exposure to electrical, mechanical and chemical hazards.

- Before installing/servicing this unit, technicians **MUST** put on all Personal Protective Equipment (PPE) recommended for the work being undertaken. **ALWAYS** refer to appropriate MSDS sheets and OSHA guidelines for proper PPE.
- When working with or around hazardous chemicals, **ALWAYS** refer to the appropriate MSDS sheets and OSHA guidelines for information on allowable personal exposure levels, proper respiratory protection and handling recommendations.
- If there is a risk of arc or flash, technicians **MUST** put on all Personal Protective Equipment (PPE) in accordance with NFPA 70E or other country-specific requirements for arc flash protection, **PRIOR** to servicing the unit.

Failure to follow recommendations could result in death or serious injury.

## Factory Warranty Information

Compliance with the following is required to preserve the factory warranty:

### **All Unit Installations**

Startup **MUST** be performed by Trane, or an authorized agent of Trane, to **VALIDATE** this **WARRANTY**. Contractor must provide a two-week startup notification to Trane (or an agent of Trane specifically authorized to perform startup).

### **Additional Requirements for Units Requiring Disassembly**

When a new fully assembled chiller is shipped and received from our Trane manufacturing location, and, for any reason, it requires disassembly or partial disassembly — which could include but is not limited to the evaporator, condenser, control panel, compressor/motor, factory-mounted starter or any other components originally attached to the fully assembled unit — compliance with the following is required to preserve the factory warranty:

- Trane, or an agent of Trane specifically authorized to perform startup and warranty of Trane® products, will perform or have direct onsite technical supervision of the disassembly and reassembly work.
- The installing contractor must notify Trane — or an agent of Trane specifically authorized to perform startup and warranty of Trane® products — two weeks in advance of the scheduled disassembly work to coordinate the disassembly and reassembly work.
- Startup must be performed by Trane or an agent of Trane specifically authorized to perform startup and warranty of Trane® products as noted above.

Trane, or an agent of Trane specifically authorized to perform startup and warranty of Trane® products, will provide qualified personnel and standard hand tools to perform the disassembly work at a location specified by the contractor. The contractor shall provide the rigging equipment such as chain falls, gantries, cranes, forklifts, etc. necessary for the disassembly and reassembly work and the required qualified personnel to operate the necessary rigging equipment.

## Introduction

This manual covers the installation, operation and maintenance of RTWD and RTUD units.

## Revision Summary

### **RLC-SVX09H-EN**

The following points describe the changes to this revision of the manual:

- Added factory warranty information.
- Corrections to Model Number descriptions.
- Updated unit dimensions and weights.

- Added Recommended Glycol information.
- Clarified requirements for liquid line service valves on RTUD units.
- Corrections to electrical data.
- Updated Customer Wire Selection tables.
- Corrected refrigeration circuit graphic in Operating Principals chapter.
- Updated Compressor Loading Sequence information.
- Updated Diagnostics lists.
- Removed electrical wiring diagrams, and added reference to new wiring diagram document.
- Miscellaneous minor corrections

## Trademarks

Trane, Series R and the Trane logo are trademarks of Trane in the United States and other countries. All trademarks referenced in this document are the trademarks of their respective owners.



# Table of Contents

Model Number Description .....	6	Condenser by Others	
Nameplates .....	6	Requirement for Stable fan operation	
Unit Nameplate .....	6	at low ambient temperatures .....	61
Compressor Nameplate .....	6	System Configuration .....	62
Model Number Coding System .....	6	Equivalent Line Length .....	62
ASME Nameplate .....	6	Liquid Line Sizing .....	62
Model Number Descriptions .....	7	Discharge (Hot Gas) Line Sizing .....	67
RTWD Model Number .....	7	Example .....	70
Compressor Model Number .....	8	Refrigerant Charge Determination .....	71
General Information .....	9	RTUD Chilled Water Flow Control .....	72
Unit Description .....	9	Oil Charge Determination .....	72
Accessory (Options Information) .....	9	Outdoor Air Temperature Sensor	
General Data .....	9	Installation Requirements .....	72
Pre-Installation .....	17	Fan Control for the Remote Air Cooled Con-	
Inspection Checklist .....	17	denser .....	72
Unit Storage .....	17	RTUD Condenser Elevation Setting .....	73
Installation requirements and Contractor		Shipping Spacers .....	74
responsibilities .....	17	Installation - Electrical .....	75
Unit Dimensions/Weights .....	18	General Recommendations .....	75
Service Clearances and Dimension .....	18	Installer-Supplied Components .....	105
Weights .....	28	Power Supply Wiring .....	106
Installation - Mechanical .....	31	Interconnecting Wiring .....	107
Location Requirements .....	31	Outdoor Air Temperature Sensor	
Noise Considerations .....	31	Installation Requirements .....	112
Foundation .....	31	Remote Air Cooled Condenser .....	112
Clearances .....	31	Fan Control for the Remote Air Cooled	
Rigging .....	31	Condenser .....	112
Lifting Procedure .....	31	Communications Interface .....	112
Unit Isolation and Leveling .....	32	RTWD/RTUD Operating Principles .....	125
Center of Gravity .....	38	General .....	125
Evaporator Piping .....	40	RTWD .....	125
Low Evap Refrigerant Cutout/Percent		RTUD .....	125
Glycol Recommendations .....	55	Refrigeration (Cooling) Cycle .....	126
Condenser Water Piping (RTWD Only) ...	56	Overview .....	126
Refrigerant Relief Valve Venting .....	57	Cycle Description .....	126
RTUD Installation .....	58	Oil System Operation (RTWD/RTUD) ...	129
Application examples .....	58	Overview .....	129
Remote Air-Cooled Condenser		Compressor Motor .....	129
Interconnection Refrigerant Piping .....	60	Compressor Rotors .....	129
		Oil Filter .....	130

Compressor Rotor Oil Supply . . . . .	130	Maintenance . . . . .	181
Compressor Bearing Oil Supply . . . . .	130	Weekly Maintenance and Checks . . . . .	181
Oil Separator . . . . .	130	Monthly Maintenance and Checks . . . . .	181
Compressor Loading Sequence . . . . .	130	Annual Maintenance . . . . .	181
Controls Interface . . . . .	131	Scheduling Other Maintenance . . . . .	182
CH530 Communications Overview . . . . .	131	Operating Log . . . . .	182
Controls Interface . . . . .	131	Service Procedures . . . . .	185
DynaView . . . . .	131	Cleaning the Condense (RTWD Only) . . . . .	185
Display Screens . . . . .	132	RTUD Air Cooled Condenser Applications -	
Main Screen . . . . .	133	High Condenser Pressure Limit and High	
Chiller Operating Mode . . . . .	133	Pressure Cutout Diagnostics . . . . .	188
Settings Screen . . . . .	138	Cleaning the Evaporator . . . . .	189
Lockout Screen . . . . .	143	Compressor Oil . . . . .	189
Power Up and Self Tests . . . . .	144	Refrigerant Charge . . . . .	191
TechView . . . . .	145	Freeze Protection . . . . .	192
Fan Configurations . . . . .	163	Diagnostics . . . . .	193
A/C Fan Controls . . . . .	163	Starter Diagnostics . . . . .	194
Low Ambient Fan Control Type . . . . .	164	Main Processor Diagnostics . . . . .	197
Fan Deck Arrangement Circuit 1 . . . . .	165	Communication Diagnostics . . . . .	208
Fan Deck Arrangement Circuit 2 . . . . .	166	Limit Conditions . . . . .	214
Example for Fan Configurations . . . . .	166	Wiring Schematics . . . . .	215
A/C Fan Controls (ACFC) . . . . .	166	Unit Electrical Data . . . . .	215
Pre-Start Checkout . . . . .	168		
Unit Voltage Power Supply . . . . .	169		
Unit Voltage Imbalance . . . . .	169		
Unit Voltage Phasing . . . . .	169		
Water System Flow Rates . . . . .	170		
Water System Pressure Drop . . . . .	170		
Unit Start-Up Procedures . . . . .	171		
Sequence of Operation . . . . .	171		
Power Up . . . . .	171		
Stopped to Starting: . . . . .	173		
Start-up . . . . .	177		
Seasonal Unit Start-Up Procedure . . . . .	177		
Unit Shutdown . . . . .	179		
Normal Shutdown to Stopped . . . . .	179		
Seasonal Unit Shutdown . . . . .	180		
Service and Maintenance . . . . .	181		
Overview . . . . .	181		



# Model Number Description

## Nameplates

The RTWD/RTUD unit nameplates are applied to the exterior surface of the control panel door.

A compressor nameplate is located on each compressor.

## Unit Nameplate

See Figure 1. Unit nameplate includes the following:

- Unit model and size descriptor.
- Unit serial number.
- Identifies unit electrical requirements.
- Lists correct operating charges of R-134a and Oil 48.
- Lists unit test pressures
- Identifies installation, operation and maintenance and service data literature.
- Lists drawing numbers for unit wiring diagrams.

Figure 1. Unit nameplate

		SERIAL NUMBER	CRC	TYPE OF USE
MODEL NUMBER				
RATED VOLTAGE/HZ/PH	MIN CKT AMPACITY	MAX OVERCURRENT PROTECTION	RATED VOLTAGE/HZ/PH	CKT 3 WATTS
VOLT UTILIZATION RANGE	CKT1		VOLT UTILIZATION RANGE	CKT 4 WATTS
	CKT2			CONVEN OUTLET
VOLT-AC	HZ	PH	RLA	Y LRA
X-L LRA				
CPSR MTR 1A				
CPSR MTR 1B				
CPSR MTR 2A				
CPSR MTR 2B				
FAN MTRS				
VFD	QTY	HP EA	FLA EA	VFD INPUT (A)
CONTROLLED FAN MTRS				MTR VOLT
INSTALLATION, OPERATION, & MAINTENANCE MANUAL		WIRING BOOK		
MIN MARKED DESIGN PSIG FOR ANY REMOTE COND		REFRIGERANT CHARGE		
		OIL CHG		
		TYPE/NUMBER		
		CKT 1 LBS		
		GAL		
		CKT 2 LBS		
		GAL		
		SHORT-CIRCUIT CURRENT RATING (A)		
		DESIGN PRESSURES PSIG		
		HIGH SIDE		
		LOW SIDE		
		MIN MARKED DESIGN PSIG FOR ANY REMOTE COND		
<small>           MANUFACTURED UNDER ONE OR MORE OF THE FOLLOWING U.S. PATENTS/            CORRESPONDING FOREIGN PATENTS OWNED BY TRANE:            6,231,046 6,418,148 6,419,105 6,434,788 6,502,884 6,563,489 6,573,058 6,590,880 6,683,104 6,698,891            6,761,914 6,805,794 6,854,484 6,920,443 6,935,851 6,949,289 6,950,088 6,987,804 6,131,471 6,161,395            6,167,113 6,269,964 6,278,122 6,282,112 6,341,992 6,341,663 6,357,238 6,382,310 6,516,627 6,563,287            6,650,122 6,666,042 6,830,099 6,868,695 7,020,156 7,086,246 7,158,121 7,202,868         </small>				
<small>Trane Made in the U.S.A. X39002356010E</small>				

## Compressor Nameplate

Compressor nameplate includes the following:

- Compressor model number.
- Compressor serial number.
- Compressor electrical characteristics.
- Utilization Range.
- Recommended refrigerant.

## Model Number Coding System

Model numbers for unit and compressors are comprised of numbers and letter which represent equipment features.

See "RTWD Model Number," p. 7 and "Compressor Model Number," p. 8 for details.

Each position, or group of positions, in a number or letter is used to represent a feature. For example, from the chart, we can determine that "F" in digit 8 of unit model number indicates unit voltage is 460/60/3.

## ASME Nameplate

The ASME nameplate is different for the evaporators, condensers (RTWD only) and oil separators. The evaporator nameplate is located on the left portion of the shell. The insulation over the nameplate is intentionally left unglued, for ease in viewing the nameplate.

The condenser nameplate is on the backside of the condenser below circuit 2 compressor.

Figure 2. Location of ASME unit nameplate - front

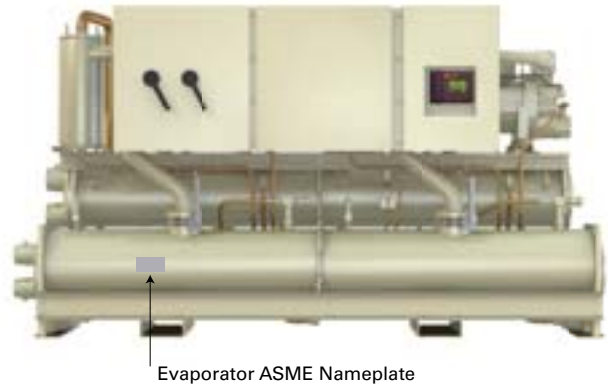
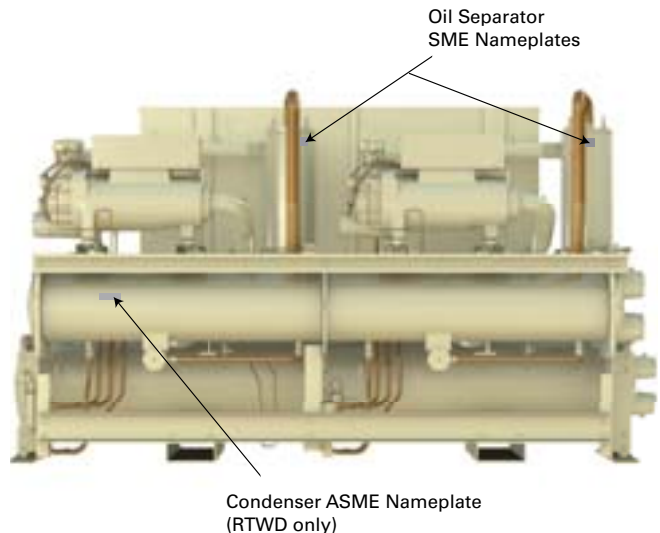

Figure 3. Location of ASME unit nameplates - back



# Model Number Descriptions

## RTWD Model Number

### Digits 1-4— Chiller Model

RTWD= Water Cooled Chiller - Series R®  
 RTUD= Compressor Series R® Chiller

### Digits 5-7— Unit Nominal Tonnage

060 = 60 Nominal Tons  
 070 = 70 Nominal Tons  
 080 = 80 Nominal Tons  
 090 = 90 Nominal Tons  
 100 = 100 Nominal Tons  
 110 = 110 Nominal Tons  
 120 = 120 Nominal Tons  
 130 = 130 Nominal Tons  
 140 = 140 Nominal Tons  
 150 = 150 Nominal Tons  
 160 = 160 Nominal Tons  
 180 = 180 Nominal Tons  
 200 = 200 Nominal Tons  
 220 = 220 Nominal Tons  
 250 = 250 Nominal Tons

### Digit 8— Unit Voltage

A = 200/60/3  
 B = 230/60/3  
 D = 380/60/3  
 E = 400/50/3  
 F = 460/60/3  
 G = 575/60/3

### Digit 9— Manufacturing Plant

2 = Pueblo, USA

### Digits 10, 11— Design Sequence

XX = Factory Assigned

### Digit 12— Unit Type

1 = Standard efficiency/performance  
 2 = High efficiency/performance  
 3 = Premium efficiency/performance

### Digit 13— Agency Listing

0 = No agency listing  
 A = UL listed to US and Canadian safety standards  
 D = IBC Seismically Rated Unit  
 E = UL/Canadian and IBC  
 F = OSHPD Seismically Rated Unit  
 G = UL/Canadian and OSHPD

### Digit 14— Pressure Vessel Code

1 = ASME pressure vessel code  
 3 = Chinese code-imported pressure vessel  
 S = Special

### Digit 15— Unit Application

A = Standard condenser (≤ 95°F/35°C entering water)  
 B = High temperature condenser (>95°F/35°C entering water)  
 C = Water-to-water heat pump  
 D = Remote condenser by Trane  
 E = Remote condenser by others

### Digit 16— Pressure Relief Valve

1 = Single relief valve  
 2 = Dual relief valve with 3-way isolation valve

### Digit 17— Water Connection Type

A = Grooved pipe connection

### Digit 18— Evaporator Tubes

A = Internal and External enhanced

### Digit 19— Number of Evaporator Passes

2 = 2-pass evaporator  
 3 = 3-pass evaporator

### Digit 20— Evaporator Water Side Pressure

A = 150 psi/10.5 bar evaporator water pressure

### Digit 21— Evaporator Application

1 = Standard cooling  
 2 = Low temperature  
 3 = Ice-making

### Digit 22— Condenser Tubes

X = Remote condenser  
 A = Enhanced fin - copper  
 B = Internally enhanced 90/10 CuNi fin

### Digit 23— Condenser Water Side Pressure

0 = Remote condenser  
 1 = 150 psi/10.5 bar condenser water pressure

### Digit 24— Compressor Starter Type

Y = Wye-delta closed transition starter  
 X = Across-the-line starter

### Digit 25— Incoming Power Line Connection

1 = Single point power connection  
 2 = Double point power connection

### Digit 26— Power Line Connection Type

A = Terminal block  
 B = Mechanical disconnect switch  
 D = Circuit breaker  
 E = High fault rated panel with circuit breaker

### Digit 27— Under/Over Voltage Protection

0 = No under/over voltage protection  
 1 = Under/over voltage protection

### Digit 28— Unit Operator Interface

A = Dyna-View/English  
 B = Dyna-View/Spanish  
 C = Dyna-View/Spanish-Mexico  
 D = Dyna-View/French  
 E = Dyna-View/German  
 F = Dyna-View/Dutch  
 G = Dyna-View/Italian  
 H = Dyna-View/Japanese  
 J = Dyna-View/Portuguese-Portugal  
 K = Dyna-View/Portuguese-Brazil  
 L = Dyna-View/Korean  
 M = Dyna-View/Thai  
 N = Dyna-View/Simplified Chinese  
 P = Dyna-View/Traditional Chinese  
 R = Dyna-View/Russian  
 T = Dyna-View/Polish  
 U = Dyna-View/Czech  
 V = Dyna-View/Hungarian  
 W = Dyna-View/Greek  
 X = Dyna-View/Romanian  
 Y = Dyna-View/Swedish

### Digit 29— Remote Interface (Digital Comm)

0 = No remote digital communication  
 A = LonTalk/Tracer Summit™ interface  
 B = Time of day scheduling  
 4 = Unit Level BACnet

### Digit 30— External Water and Current Limit Setpoint

0 = No external water and current limit setpoint  
 A = External water and current limit setpoint 4-20 mA  
 B = External water and current limit setpoint 2-10 Vdc

### Digit 31— Ice Making

0 = No ice making  
 A = Ice making with relay  
 B = Ice making without relay

### Digit 32— Programmable Relays

0 = No programmable relays  
 A = Programmable relays

### Digit 33— Condenser Refrigerant Pressure Output Option

0 = No condenser refrigerant output  
 1 = Condenser water control output  
 2 = Condenser pressure (%HPC) output  
 3 = Differential pressure output

### Digit 34— Outdoor Air Temp Sensor

0 = No outdoor air temp sensor  
 A = Outdoor air temp sensor - CWR (low ambient)

**Digit 35— Condenser Leaving Hot Water Temp Control**

- 0 = No condenser leaving hot water temperature control
- 1 = Condenser leaving hot water temperature control

**Digit 36— Power Meter**

- 0 = No power meter
- P = Power meter

**Digit 37— Motor Current Analog Output (%RLA)**

- 0 = No motor current analog output
- 1 = Motor current analog output

**Digit 38— A/C Fan Control**

- 0 = No fan controls (RTWD)
- A = Fan control by others
- B = Integral fan controls

**Digit 39— Low Ambient Fan Control Type**

- 0 = No low ambient fan control type (RTWD)
- 1 = Two speed fan
- 2 = Variable speed fan with analog interface
- 3 = Variable speed fan with PWM interface

**Digit 40— Installation Accessories**

- 0 = No installation accessories (shipped with elastomeric pad)
- A = Elastomeric (neoprene) isolators
- B = Flanged water connection kit
- C = Isolators and flanged water connection kit

**Digit 41— Flow Switch**

- 0 = No flow switch
- 1 = 150 psi NEMA 1; flow switch x 1
- 2 = 150 psi NEMA 1; flow switch x 2
- 3 = 150 psi NEMA 4; flow switch x 1
- 4 = 150 psi NEMA 4; flow switch x 2
- 7 = Factory installed proof of evaporator and condenser
- 8 = Factory installed proof of evaporator
- 9 = Factory installed proof of condenser

**Digit 42— 2-Way Water Regulating Valve**

- 0 = No 2-way water regulating valve
- A = 3" 150psi/88.9mm 10.5 bar 115V
- B = 3" 150psi/88.9mm 10.5 bar 220V
- C = 3" 150psi/114.3mm 10.5bar 115V
- D = 3" 150psi/114.3mm 10.5bar 220V

**Digit 43— Sound Reduction Package**

- 0 = No sound reduction package
- A = Sound reduction - factory installed

**Digit 44— Insulation**

- 0 = No insulation
- 1 = Factory insulation, all cold parts
- 2 = Insulation for high humidity

**Digit 45— Factory Charge**

- 0 = Full factory refrigerant charge (R-134a)
- 1 = Nitrogen charge

**Digit 46— Base Rail Forklifting**

- 0 = No base rail forklifting
- B = Base rail forklifting

**Digit 47— Label and Literature Language**

- B = Spanish
- D = English
- E = French
- G = Chinese - traditional

**Digit 48— Special**

- 0 = None
- A = Special

**Digits 49-55**

- 0 = None (not used)

**Digit 56— Shipping Package**

- 0 = No skid (standard)
- 1 = Skid
- 2 = Shrink wrap
- 3 = Skid and shrink wrap

**Digits 57-58**

- x = Factory assigned

**Digit 59— Performance Test Options**

- 0 = No performance test
- C = 1 point test with report
- D = 2 point test with report
- E = 3 point test with report
- F = 4 point test with report
- G = Witness 1 point test with report
- H = Witness 2 point test with report
- J = Witness 3 point test with report
- K = Witness 4 point test with report

**Digit 60— Evaporator Fluid Type**

- 0 = Water
- 1 = Calcium chloride
- 2 = Ethylene glycol
- 3 = Propylene glycol
- 4 = Methanol

## Compressor Model Number

**Digits 1-4— Compressor Model**

CHHN= Positive displacement, helical rotary (twin screw) hermetic compressor

**Digits 5-7— Size**

- 0N2= 120 Tons
- 0N1= 100 Tons
- 0M2= 85 Tons
- 0M1= 70 Tons
- 0L2= 60 Tons
- 0L1= 50 Tons
- 0K2= 40 Tons
- 0K1= 35 Tons

**Digit 8— Unit Voltage**

- A = 200/60/3
- R = 220/50/3
- C = 230/60/3
- D = 380/60/3
- H = 575/60/3
- T = 460/60/3 or 400/50/3

**Digit 9— Internal Relief**

- K = 450 psid

**Digits 10, 11— Design Sequence**

- XX = Factory Assigned

**Digit 12— Capacity Limit**

- N = Standard capacity controls (no capacity limit)

**Digits 13-15— Motor kW Rating**

- 134 = 134 kW (N2/60Hz)
- 112 = 112 kW (N2/50Hz)
- 092 = 092 kW (M2/60Hz)
- 077 = 077 kW (M2/50Hz)
- 069 = 069 kW (L2/60Hz)
- 058 = 058 kW (L2/50Hz)
- 050 = 050 kW (K2/60Hz)
- 041 = 041 kW (K2/50Hz)
- 112 = 112 kW (N1/60Hz)
- 093 = 093 kW (N1/50Hz)
- 077 = 077 kW (M1/60Hz)
- 065 = 065 kW (M1/50Hz)
- 057 = 057 kW (L1/60Hz)
- 048 = 048 kW (L1/60Hz)
- 043 = 043 kW (K1/60Hz)
- 036 = 036 kW (K1/60Hz)

**Digit 16— Volume Ratio**

- A = High volume ratio
- N = Low volume ratio



# General Information

## Unit Description

The RTWD units are helical-rotary type, water-cooled, liquid chillers, designed for installation indoors. The units have 2 independent refrigerant circuits, with one compressor per circuit. The RTWD units are packaged with an evaporator and condenser.

Note: Each RTWD unit is a completely assembled, hermetic package that is factory-piped, wired, leak-tested, dehydrated, charged and tested for proper control operations prior to shipment. The chilled water inlet and outlet openings are covered for shipment.

The RTWD series features Trane's exclusive Adaptive Control logic with CH530 controls. It monitors the control variables that govern the operation of the chiller unit. Adaptive Control logic can correct these variables, when necessary, to optimize operational efficiencies, avoid chiller shutdown, and keep producing chilled water.

Compressor unloaders are solenoid actuated. Each refrigerant circuit is provided with filter, sight glass, electronic expansion valve, and charging valves on the RTWD.

The evaporator and condenser are manufactured in accordance with ASME standards. The evaporator is fully insulated. Both evaporator and condenser are equipped with water drain and vent connections.

The RTUD units are helical-rotary type compressor chillers, designed to be most effective when used with the Levitor II air-cooled condenser. The RTUD unit consists of an evaporator, two helical rotary compressors (one per circuit), oil separators, oil coolers, liquid line service valves, sightglasses, electronic expansion valves and filter. The discharge line leaving the oil separator and liquid line entering the filters are capped and brazed. The unit ships with a full charge of oil and a nitrogen holding charge.

## Accessory/Options Information

Check all the accessories and loose parts which are shipped with the unit against the original order. Included in these items will be water vessel drain plugs, rigging diagrams, electrical diagrams, and service literature, which are placed inside the control panel and/or starter panel for shipment. Also check for optional components, such as flow switches and isolators.

## General Data

**Table 1. General Data - RTWD - 60 Hz - premium efficiency**

Size		150	160	180	200
<b>Compressor</b>		L2/M1	M1/M1	M1/M2	M2/M2
Quantity		2	2	2	2
Nominal Size		65/70	70/70	70/85	85/85
<b>Evaporator</b>		2 Pass Arrangement			
Water Conn. Size	NPS	6	6	6	6
	mm	150	150	150	150
Water Storage	(gal)	27.8	27.8	29.3	31.3
	(L)	105.1	105.1	110.9	118.3
Minimum Flow	(gpm)	174	174	186	202
	(L/s)	11.0	11.0	11.8	12.7
Maximum Flow	(gpm)	639	639	683	739
	(L/s)	40.3	40.3	43.1	46.7
		3 Pass Arrangement			
Water Conn. Size	NPS	4	4	4	4
	mm	100	100	100	100
Water Storage	(gal)	27.1	27.1	28.6	30.6
	(L)	102.4	102.4	108.3	115.7
Minimum Flow	(gpm)	116	116	124	134
	(L/s)	7.3	7.3	7.8	8.5
Maximum Flow	(gpm)	426	426	456	493
	(L/s)	26.9	26.9	28.7	31.1
<b>Condenser</b>					
Water Conn. Size	NPS	6	6	6	6
	mm	150	150	150	150
Water Storage	(gal)	30.0	30.0	32.9	32.9
	(L)	113.4	113.4	124.4	124.4
Minimum Flow	(gpm)	206	206	231	231
	(L/s)	13	13	14.6	14.6
Maximum Flow	(gpm)	755	755	845	845
	(L/s)	47.6	47.6	53.3	53.3
<b>General Unit</b>					
Refrig Type		R-134a	R-134a	R-134a	R-134a
# Refrig Circuits		2	2	2	2
Refrigerant Charge	(lb)	174.2/ 183.0	183.0/ 183.0	180.8/ 180.8	178.6/ 178.6
	(kg)	79/83	83/83	82/82	81/81
Oil Charge	(qts)	10.5/12.4	12.4/12.4	12.4/12.4	12.4/12.4
	(L)	9.9/11.7	11.7/11.7	11.7/11.7	11.7/11.7

**Notes:**

1. Data containing information on two circuits is shown as circuit 1/ circuit 2.
2. Flow limits are for water only.



## General Information

**Table 2. General Data - RTWD - 60 Hz - standard efficiency**

Size		80	90	100	110	120	130	140
<b>Compressor</b>		K1/K1	K2/K2	K2/L1	L1/L1	L1/L2	L2/L2	L2/M1
Quantity		2	2	2	2	2	2	2
Nominal Size		40/40	45/45	45/55	55/55	55/65	65/65	65/70
<b>Evaporator</b>								
2 Pass Arrangement								
Water Conn. Size	NPS	4	4	4	4	5	5	5
	mm	100	100	100	100	125	125	125
Water Storage	(gal)	11.2	11.2	12.6	14	15.2	16.2	17.7
	(L)	42.2	42.2	47.6	53.0	57.4	61.5	66.8
Minimum Flow	(gpm)	77	77	89	101	101	110	122
	(L/s)	4.9	4.9	5.6	6.4	6.4	6.9	7.7
Maximum Flow	(gpm)	281	281	325	368	368	400	444
	(L/s)	17.7	17.7	20.5	23.2	23.2	25.2	28
3 Pass Arrangement								
Water Conn. Size	NPS	3	3	3	3	4	4	4
	mm	80	80	80	80	100	100	100
Water Storage	(gal)	11.2	11.2	12.6	14	15.2	16.2	17.7
	(L)	42.2	42.2	47.6	53.0	57.4	61.5	66.8
Minimum Flow	(gpm)	52	52	59	67	67	73	81
	(L/s)	3.3	3.3	3.8	4.3	4.3	4.6	5.1
Maximum Flow	(gpm)	187	187	216	244	244	266	295
	(L/s)	11.8	11.8	13.6	15.4	15.4	16.8	18.6
<b>Condenser</b>								
Water Conn. Size	NPS	5	5	5	5	5	5	5
	mm	125	125	125	125	125	125	125
Water Storage	(gal)	12.4	14.2	16.0	16.9	18.5	18.5	20.9
	(L)	46.8	53.6	60.4	63.8	70.1	70.1	79.2
Minimum Flow	(gpm)	83	99	115	124	135	135	156
	(L/s)	5.2	6.3	7.3	7.8	8.5	8.5	9.9
Maximum Flow	(gpm)	301	361	421	451	491	491	572
	(L/s)	18.9	22.7	26.5	28.4	31.0	31.0	36.0
<b>General Unit</b>								
Refrigerant Type		R-134a	R-134a	R-134a	R-134a	R-134a	R-134a	R-134a
# Refrig Circuits		2	2	2	2	2	2	2
Refrigerant Charge	(lb)	114.6/114.6	114.6/114.6	112.4/114.6	112.4/112.4	132.3/132.3	130.1/130.1	127.9/132.3
	(kg)	52/52	52/52	51/52	51/51	60/60	59/59	58/60
Oil Charge	(quarts)	7.2/7.2	7.2/7.2	7.2/10.5	10.5/10.5	10.5/10.5	10.5/10.5	10.5/10.5
	(L)	6.8/6.8	6.8/6.8	6.8/9.9	9.9/9.9	9.9/9.9	9.9/9.9	9.9/9.9

**Notes:**

1. Data containing information on two circuits is shown as circuit 1/circuit 2.
2. Flow limits are for water only.

## General Information

**Table 3. General Data - RTWD - 60 Hz - high efficiency**

Size		80	90	100	110	120	130	150	160	180	200	220	250
<b>Compressor</b>		K1/K1	K2/K2	K2/L1	L1/L1	L1/L2	L2/L2	L2/M1	M1/M1	M1/M2	M2/M2	M2/N1	N1/N1
Quantity		2	2	2	2	2	2	2	2	2	2	2	2
Nominal Size		40/40	45/45	45/55	55/55	55/65	65/65	65/70	70/70	70/85	85/85	85/100	100/100
<b>Evaporator</b>													
2 Pass Arrangement													
Water Conn. Size	NPS	4	4	5	5	5	5	5	5	5	5	6	6
	mm	100	100	100	125	125	125	125	125	125	125	150	150
Water Storage	(gal)	9.8	11.9	12.8	15.3	16.4	17.3	19.2	20.3	22.3	24.2	28.6	31.8
	(L)	37.0	45.2	48.3	57.9	62.3	65.4	72.6	77.0	84.5	91.	108.3	120.3
Minimum Flow	(gpm)	72	92	100	112	123	130	141	151	170	186	211	240
	(L/s)	4.6	5.8	6.3	7.1	7.8	8.2	8.9	9.5	10.7	11.8	13.3	15.1
Maximum Flow	(gpm)	263	336	364	409	448	476	515	555	622	683	773	879
	(L/s)	16.6	21.2	22.9	25.8	28.2	30.0	32.5	35.0	39.2	43.1	48.8	55.5
3 Pass Arrangement													
Water Conn. Size	NPS	3	3	4	4	4	4	4	4	4	4	4	4
	mm	80	80	80	100	100	100	100	100	100	100	100	100
Water Storage	(gal)	9.8	11.9	12.8	15.3	16.4	17.3	18.8	20.0	22.0	23.8	27.9	31.0
	(L)	37.0	45.2	48.3	57.9	62.3	65.4	71.2	75.6	83.2	90.1	105.5	117.5
Minimum Flow	(gpm)	48	61	67	75	82	87	94	101	113	124	141	160
	(L/s)	3.1	3.9	4.2	4.7	5.2	5.5	5.9	6.4	7.1	7.8	8.9	10.1
Maximum Flow	(gpm)	175	223	242	271	298	316	344	370	415	456	515	586
	(L/s)	11.0	14.1	15.2	17.1	18.8	19.9	21.7	23.3	26.2	28.7	32.5	37.0
<b>Condenser</b>													
Water Conn. Size	NPS	5	5	5	5	5	5	6	6	6	6	6	6
	mm	125	125	125	125	125	125	150	150	150	150	150	150
Water Storage	(gal)	11.9	12.7	14.9	16.6	17.2	18.0	21.6	22.9	24.6	26.2	31.1	39.2
	(L)	45.1	48.1	56.3	62.7	65.2	68.3	81.7	86.8	93.0	99.2	117.8	148.3
Minimum Flow	(gpm)	87	95	117	130	136	145	159	173	189	206	244	325
	(L/s)	5.5	6.0	7.4	8.2	8.6	9.1	10.1	10.9	12.0	13.0	15.4	20.5
Maximum Flow	(gpm)	317	347	427	473	498	528	584	634	695	755	896	1193
	(L/s)	20.0	21.9	26.9	29.8	31.4	33.3	36.8	40.0	43.8	47.6	56.5	75.3
<b>General Unit</b>													
Refrigerant Type		R-134a	R-134a	R-134a	R-134a	R-134a	R-134a	R-134a	R-134a	R-134a	R-134a	R-134a	R-134a
# Refrig Circuits		2	2	2	2	2	2	2	2	2	2	2	2
Refrigerant Charge	(lb)	99.2/ 99.2	97/97	123.5/ 125.7	123.5/ 123.5	121.3/ 121.3	119/ 119	134.5/ 143.3	141.1/ 141.1	138.9/ 138.9	136.7/ 136.7	178.6/ 185.2	180.8/ 180.8
	(kg)	45/45	44/44	56/57	56/56	55/55	54/54	61/65	64/64	63/63	62/62	81/84	82/82
Oil Charge	(qt)	7.2/7.2	7.2/7.2	7.2/10.5	10.5/ 10.5	10.5/ 10.5	10.5/ 10.5	10.5/ 10.5	12.4/ 12.4	12.4/ 12.4	12.4/ 12.4	12.4/ 12.4	12.4/ 12.4
	(L)	6.8/6.8	6.8/6.8	6.8/9.9	9.9/9.9	9.9/9.9	9.9/9.9	9.9/11.7	11.7/ 11.7	11.7/ 11.7	11.7/ 11.7	11.7/ 11.7	11.7/ 11.7

**Notes:**

1. Data containing information on two circuits is shown as circuit 1/circuit 2.
2. Flow limits are for water only.



## General Information

**Table 4. General Data – RTUD – 60 Hz**

Size		80	90	100	110	120	130	150	160	180	200	220	250
<b>Compressor</b>		K1/K1	K2/K2	K2/L1	L1/L1	L1/L2	L2/L2	L2/M1	M1/M1	M1/M2	M2/M2	M2/N1	N1/N1
Quantity		2	2	2	2	2	2	2	2	2	2	2	2
Nominal Size		40/40	45/45	45/55	55/55	55/65	65/65	65/70	70/70	70/85	85/85	85/100	100/100
<b>Evaporator</b>													
2 Pass Arrangement													
Water Conn. Size	NPS	4	4	4	5	5	5	5	5	5	5	5	5
	mm	100	100	100	125	125	125	125	125	125	125	125	125
Water Storage	(gal)	9.8	10.6	12.0	14.0	15.3	15.3	16.5	19.2	19.2	20.3	22.3	24.2
	(L)	37.1	40.2	45.3	53.0	58.0	58.0	62.4	72.6	72.6	77.0	84.5	91.5
Minimum Flow	(gpm)	77	79	91	99	111	111	122	140	140	151	169	186
	(L/s)	4.9	5.0	5.7	6.2	7.0	7.0	7.7	8.8	8.8	9.5	10.7	11.7
Maximum Flow	(gpm)	281	291	335	363	408	408	447	514	514	553	620	681
	(L/s)	17.7	21.2	23.0	25.8	28.3	30.0	28.2	32.4	32.4	34.9	39.1	43.0
3 Pass Arrangement													
Water Conn. Size	NPS	3	3	3	4	4	4	4	4	4	4	4	4
	mm	80	80	80	100	100	100	100	100	100	100	100	100
Water Storage	(gal)	9.5	10.3	11.6	13.7	15.1	15.1	16.1	18.8	18.8	20.0	22.0	23.8
	(L)	36.0	39.0	44.0	52.0	57.0	57.0	61.0	71.2	71.2	75.6	83.2	90.1
Minimum Flow	(gpm)	51	53	61	66	74	74	81	94	94	100	112	124
	(L/s)	3.2	3.3	3.8	4.2	4.7	4.7	5.1	5.9	5.9	6.3	7.1	7.8
Maximum Flow	(gpm)	187	194	224	242	272	272	298	343	343	368	413	454
	(L/s)	11.8	12.2	14.1	15.3	17.2	17.2	18.8	21.6	21.6	23.2	26.1	28.6
<b>General Unit</b>													
Refrigerant Type		R-134a	R-134a	R-134a	R-134a	R-134a	R-134a	R-134a	R-134a	R-134a	R-134a	R-134a	R-134a
# Refrig Circuits		2	2	2	2	2	2	2	2	2	2	2	2
Refrigerant Charge	(lb)	50/50	49/49	47/47	65/65	64/64	64/64	62/62	66/66	66/66	66/66	63/63	61/61
	(kg)	22.7/22.7	22.2/22.2	21.3/21.3	29.5/29.5	29.0/29.0	29.0/29.0	28.1/28.1	29.9/29.9	29.9/29.9	29.9/29.9	28.6/28.6	27.7/27.7
Oil Charge	(qt)	7.2/7.2	7.2/7.2	7.2/10.5	10.5/10.5	10.5/10.5	10.5/10.5	10.5/10.5	10.5/10.5	10.5/12.4	12.4/12.4	12.4/12.4	12.4/12.4
	(L)	6.8/6.8	6.8/6.8	6.8/9.9	9.9/9.9	9.9/9.9	9.9/9.9	9.9/9.9	9.9/9.9	9.9/11.7	11.7/11.7	11.7/11.7	11.7/11.7
Discharge Connection Diameter	(inch)	2.1	2.1	2.1	2.6	2.6	2.6	2.6	3.1	3.1	3.1	3.1	3.1
Liquid Connection Diameter	(inch)	1.1	1.1	1.1	1.4	1.4	1.4	1.4	1.4	1.4	1.4	1.4	1.6

- Notes:**  
**1.** Data containing information on two circuits is shown as circuit 1/circuit 2.  
**2.** Flow limits are for water only.

## General Information

**Table 5. General Data – Condenser by Trane – 60 Hz**

Size	80	90	100	110	120	130	150	160	180	200	220	250
<b>Condenser</b>												
Condenser Quantity	1	1	1	1	1	1	2	2	2	2	2	2
Fins/Inch	12	10	10	12	8	10	8/12	12/12	12/8	8/8	8/10	10/10
Coil Length (in)	162	216	216	216	270	270	162/162	162/162	162/216	216/216	216/216	216/216
(mm)	4115	5486	5486	5486	6858	6858	4115/4115	4115/4115	4115/5486	5486/5486	5486/5486	5486/5486
Coil Width (in)	85	85	85	85	85	85	85/85	85/85	85/85	85/85	85/85	85/85
(mm)	2159	2159	2159	2159	2159	2159	2159/2159	2159/2159	2159/2159	2159/2159	2159/2159	2159/2159
Number of Rows	3	3	4	4	4	4	3/3	3/3	3/3	3/3	3/4	4/4
<b>Condenser Fans</b>												
Fan Quantity	6	8	8	8	10	10	6/6	6/6	6/8	8/8	8/8	8/8
Diameter (in)	30	30	30	30	30	30	30	30	30	30	30	30
(mm)	762	762	762	762	762	762	762	762	762	762	762	762
Nominal RPM (rpm)	850	850	850	850	850	850	850	850	850	850	850	850
Air Flow (cfm)	56,646	78,280	72,248	69,280	94,490	90,310	60,954/56,646	56,646/56,646	56,646/81,272	81,272/81,272	81,272/72,248	72,248/72,248
Tip Speed (fpm)	6676	6676	6676	6676	6676	6676	6676	6676	6676	6676	6676	6676
Motor HP (hp)	1.5	1.5	1.5	1.5	1.5	1.5	1.5	1.5	1.5	1.5	1.5	1.5
<b>General</b>												
Recommended Refrigerant Charge <sup>1</sup> (lbs)	55/55	92/92	97/97	97/97	98/98	122/122	109/109	109/109	109/146	146/146	146/195	195/195
(kg)	24.9/24.9	41.7/41.7	44.0/44.0	44.0/44.0	44.5/44.5	55.3/55.3	49.4/49.4	49.4/49.4	49.4/66.2	66.2/66.2	66.2/88.5	88.5/88.5
Discharge/Liquid Connection Diameters (in)	2.1	2.1	2.1	2.1	2.1	2.1	2.125	2.125	2.125	2.125	2.125	2.125
(mm)	54	54	54	54	54	54	54	54	54	54	54	54

**Notes:**

1. Data containing information on two condensers is shown as cond 1/cond 2.
2. Data containing information on two circuits is shown as circuit 1/circuit 2.
3. Condenser is not factory charged, the refrigerant must be purchased and charged in the field.



## General Information

**Table 6. General Data - RTWD 50 Hz - standard efficiency**

Size		70	80	90	100	110	120	130	140	150
<b>Compressor</b>		K2/K2	K2/L1	L1/L1	L1/L2	L2/L2	L2/M1	M1/M1	M1/M2	M2/M2
Quantity		2	2	2	2	2	2	2	2	2
Nominal Size		45/45	45/55	55/55	55/65	65/65	65/70	70/70	70/85	85/85
<b>Evaporator</b>										
2 Pass Arrangement										
Water Conn. Size	NPS	4	4	4	4	4	5	5	5	5
	mm	100	100	100	100	100	125	125	125	125
Water Storage	(gal)	11.2	12.6	14.0	14.0	14.0	16.2	17.7	17.7	19.1
	(L)	42.2	47.6	53.0	53.0	53.0	61.5	66.8	66.8	72.2
Minimum Flow	(gpm)	77	89	101	101	101	110	122	122	133
	(L/s)	4.9	5.6	6.3	6.3	6.3	6.9	7.7	7.7	8.4
Maximum Flow	(gpm)	281	324	368	368	368	400	444	444	487
	(L/s)	17.7	20.5	23.2	23.2	23.2	25.2	28.0	28.0	30.7
3 Pass Arrangement										
Water Conn. Size	NPS	3	3	3	3	3	4	4	4	4
	mm	80	80	80	80	80	100	100	100	100
Water Storage	(gal)	11.2	12.6	14.0	14.0	14.0	16.2	17.7	17.7	19.1
	(L)	42.2	47.6	53.0	53.0	53.0	61.5	66.8	66.8	72.2
Minimum Flow	(gpm)	52	59	67	67	67	73	81	81	89
	(L/s)	3.3	3.8	4.3	4.3	4.3	4.6	5.1	5.1	5.6
Maximum Flow	(gpm)	187	216	244	244	244	266	295	295	324
	(L/s)	11.8	13.6	15.4	15.4	15.4	16.8	18.6	18.6	20.4
<b>Condenser</b>										
Water Conn. Size	NPS	5	5	5	5	5	5	5	5	5
	mm	125	125	125	125	125	125	125	125	125
Water Storage	(gal)	12.4	14.2	16.0	16.9	16.9	18.5	20.9	20.9	22.4
	(L)	46.8	53.6	60.4	63.8	63.8	70.1	79.2	79.2	84.8
Minimum Flow	(gpm)	83	99	115	124	124	135	156	156	170
	(L/s)	5.2	6.3	7.3	7.8	7.8	8.5	9.9	9.9	10.8
Maximum Flow	(gpm)	301	361	421	451	451	491	571	571	622
	(L/s)	18.9	22.7	26.5	28.4	28.4	31.0	36.0	36.0	39.2
<b>General Unit</b>										
Refrigerant Type		R134a	R134a	R134a	R134a	R134a	R134a	R134a	R134a	R134a
# Refrig Circuits		2	2	2	2	2	2	2	2	2
Refrigerant Charge	(lb)	114.6/ 114.6	112.4/ 112.4	110.2/ 110.2	110.2/ 112.4	112.4/ 112.4	130.1/ 130.1	127.9/ 127.9	127.9/ 132.3	130.1/ 130.1
	(kg)	52/52	51/51	50/50	50/51	51/51	59/59	58/58	58/60	59/59
Oil Charge	(quarts)	7.2/7.2	7.2/7.2	7.2/7.2	7.2/10.5	10.5/10.5	10.5/10.5	10.5/10.5	10.5/10.5	10.5/10.5
	(L)	6.8/6.8	6.8/6.8	6.8/6.8	6.8/9.9	9.9/9.9	9.9/9.9	9.9/9.9	9.9/9.9	9.9/9.9

**Notes:**

1. Data containing information on two circuits is shown as circuit 1/circuit 2.
2. Flow limits are for water only.

## General Information

**Table 7. General Data - RTWD 50 Hz - high efficiency**

Size	60	70	80	90	100	110	120	130	140	160	180	200	220	250
<b>Compressor</b>	K1/K1	K2/K2	K2/L1	L1/L1	L1/L2	L2/L2	L2/M1	M1/M1	M1/M2	M2/M2	M2/N1	N1/N1	N1/N2	N2/N2
Quantity	2	2	2	2	2	2	2	2	2	2	2	2	2	2
Nominal Size	40/40	45/45	45/55	55/55	55/65	65/65	65/70	70/70	70/85	85/85	85/100	100/100	100/120	120/120
<b>Evaporator</b>														
2 Pass Arrangement														
Water NPS	4	4	4	5	5	5	5	5	5	5	5	6	6	6
Conn. Size mm	100	100	100	125	125	125	125	125	125	125	125	150	150	150
Water (gal)	9.8	10.6	11.9	15.3	15.3	16.4	17.3	19.2	20.3	22.3	24.2	28.6	29.9	31.8
Storage (L)	37.0	40.2	45.2	57.9	57.9	62.3	65.4	72.6	77.0	84.5	91.5	108.3	113.3	120.3
Minimum (gpm)	72	80	92	112	112	123	130	141	151	170	186	211	223	240
Flow (L/s)	4.6	5.1	5.8	7.1	7.1	7.8	8.2	8.9	9.5	10.7	11.8	13.3	14.1	15.1
Maximum (gpm)	263	291	336	408	408	448	476	515	555	622	683	773	818	879
Flow (L/s)	16.6	18.3	21.2	25.8	25.8	28.2	30.0	32.5	35.0	39.2	43.1	48.8	51.6	55.5
3 Pass Arrangement														
Water NPS	3	3	3	4	4	4	4	4	4	4	4	4	4	4
Conn. Size mm	80	80	80	100	100	100	100	100	100	100	100	100	100	100
Water (gal)	9.8	10.6	11.9	15.3	15.3	16.4	17.3	18.8	20.0	22.0	23.8	27.9	29.2	31.0
Storage (L)	37.0	40.2	45.2	57.9	57.9	62.3	65.4	71.2	75.6	83.2	90.1	105.5	110.5	117.5
Minimum (gpm)	48	53	61	75	75	82	86	94	101	113	124	141	149	160
Flow (L/s)	3.1	3.4	3.9	4.7	4.7	5.2	5.5	5.9	6.4	7.1	7.8	8.9	9.4	10.1
Maximum (gpm)	175	193	223	271	271	298	316	344	370	415	456	515	545	586
Flow (L/s)	11.0	12.2	14.1	17.1	17.1	18.8	19.9	21.7	23.3	26.2	28.7	32.5	34.4	37.0
<b>Condenser</b>														
Water NPS	5	5	5	5	5	5	5	6	6	6	6	6	6	6
Conn. Size mm	125	125	125	125	125	125	125	150	150	150	150	150	150	150
Water (gal)	11.9	11.9	13.8	15.3	16.6	16.6	18.0	21.6	22.9	24.6	26.2	31.1	31.1	35.2
Storage (L)	45.1	45.1	52.2	58.1	62.7	62.7	68.3	81.7	86.8	93.0	99.2	117.8	117.8	133.3
Minimum (gpm)	87	87	106	117	130	130	145	159	173	189	206	244	244	286
Flow (L/s)	5.5	5.5	6.7	7.4	8.2	8.2	9.1	10.0	10.9	11.9	13.0	15.4	15.4	18.0
Maximum (gpm)	317	317	387	427	473	473	528	584	634	695	755	896	896	1047
Flow (L/s)	20.0	20.0	24.4	26.9	29.8	29.8	33.3	36.8	40.0	43.8	47.6	56.5	56.5	66.1
<b>General Unit</b>														
Refrig Type	R-134a	R-134a	R-134a	R-134a	R-134a	R-134a	R-134a	R-134a	R-134a	R-134a	R-134a	R-134a	R-134a	R-134a
# Refrig Circuits	2	2	2	2	2	2	2	2	2	2	2	2	2	2
Refrigerant Charge (lb)	99.2/99.2	99.2/99.2	97/97	121.3/121.3	121.3/123.5	121.3/121.3	119/119	134.5/134.5	132.3/136.7	134.5/134.5	132.3/136.7	178.6/178.6	176.4/183.0	180.8/180.8
(kg)	45/45	45/45	44/44	55/55	55/56	55/55	54/54	61/61	60/62	61/61	60/62	81/81	80/83	82/82
Oil Charge (qts)	7.2/7.2	7.2/7.2	7.2/7.2	7.2/7.2	7.2/10.5	10.5/10.5	10.5/10.5	10.5/10.5	10.5/10.5	10.5/10.5	10.5/10.5	12.4/12.4	12.4/12.4	12.4/12.4
(L)	6.8/6.8	6.8/6.8	6.8/6.8	6.8/6.8	6.8/9.9	9.9/9.9	9.9/9.9	9.9/9.9	9.9/9.9	9.9/9.9	9.9/9.9	11.7/11.7	11.7/11.7	11.7/11.7

**Notes:**

1. Data containing information on two circuits is shown as circuit 1/circuit 2.
2. Flow limits are for water only.



## General Information

**Table 8. General Data - RTWD 50 Hz - premium efficiency**

<b>Size</b>		<b>160</b>	<b>180</b>	<b>200</b>
<b>Compressor</b>		M2/M2	M2/N1	N1/N1
	Quantity	2	2	2
	Nominal Size	85/85	85/100	100/100
<b>Evaporator</b>				
2 Pass Arrangement				
Water Conn. Size	NPS	6	6	6
	mm	150	150	150
Water Storage	(gal)	29.3	31.3	31.8
	(L)	110.9	118.3	120.3
Minimum Flow	(gpm)	186	202	240
	(L/s)	11.8	12.7	15.1
Maximum Flow	(gpm)	683	739	879
	(L/s)	43.1	46.7	55.5
3 Pass Arrangement				
Water Conn. Size	NPS	4	4	4
	mm	100	100	100
Water Storage	(gal)	28.6	30.6	31.0
	(L)	108.3	115.7	117.5
Minimum Flow	(gpm)	124	134	160
	(L/s)	7.8	8.5	10.1
Maximum Flow	(gpm)	456	493	586
	(L/s)	28.7	31.1	37.0
<b>Condenser</b>				
Water Conn. Size	NPS	6	6	6
	mm	150	150	150
Water Storage	(gal)	30.0	34.5	39.2
	(L)	113.4	130.6	148.3
Minimum Flow	(gpm)	206	244	325
	(L/s)	13.0	15.4	20.5
Maximum Flow	(gpm)	755	896	1193
	(L/s)	47.6	56.5	75.3
<b>General Unit</b>				
Refrigerant Type		R-134a	R-134a	R-134a
# Refrig Circuits		2	2	2
Refrigerant Charge	(lb)	176.4/176.4	176.6/178.6	176.4/174.2
	(kg)	80/80	79/81	80/79
Oil Charge	(qts)	10.5/10.5	10.5/12.4	12.4/12.4
	(L)	9.9/9.9	9.9/11.7	11.7/11.7

1. Data containing information on two circuits is shown as circuit 1/circuit 2.
2. Flow limits are for water only.



# Pre-Installation

## Inspection Checklist

When the unit is delivered, verify that it is the correct unit and that it is properly equipped. Compare the information which appears on the unit nameplate with the ordering and submittal information. See “Model Number Descriptions,” p. 7.

Inspect all exterior components for visible damage. Report any apparent damage or material shortage to the carrier and make a “unit damage” notation on the carrier's delivery receipt. Specify the extent and type of damage found and notify the appropriate Trane Sales Office.

**Important:** Do not proceed with installation of a damaged unit without sales office approval.

To protect against loss due to damage incurred in transit, complete the following checklist upon receipt of the unit.

- Inspect the individual pieces of the shipment before accepting the unit. Check for obvious damage to the unit or packing material.
- Inspect the unit for concealed damage as soon as possible after delivery and before it is stored. Concealed damage must be reported within 15 days.
- If concealed damage is discovered, stop unpacking the shipment. Do not remove damaged material from the receiving location. Take photos of the damage, if possible. The owner must provide reasonable evidence that the damage did not occur after delivery.
- Notify the carrier's terminal of the damage immediately, by phone and by mail. Request an immediate, joint inspection of the damage with the carrier and the consignee.
- Notify the Trane sales representative and arrange for repair. Do not repair the unit, however, until damage is inspected by the carrier's representative.

## Unit Storage

If the chiller is to be stored for more than one month prior to installation, observe the following precautions:

- Do not remove the protective coverings from the electrical panel.
- Store the chiller in a dry, vibration-free, secure area.
- At least every three months, attach a gauge and manually check the pressure in the refrigerant circuit. If the refrigerant pressure is below 71 psig at 70 F (or 46 psig at 50 F), call a qualified service organization and the appropriate Trane sales office.

**Note:** Pressure will be approximately 20 psig if shipped with the optional nitrogen charge.

## Installation requirements and Contractor responsibilities

A list of the contractor responsibilities typically associated with the unit installation process is provided in [Table 9](#).

**Note:** Unit Start-up must be completed by a qualified Trane service technician.

**Table 9. Installation requirements**

Type of Rqmt	Trane Supplied		Field Supplied Field Installed
	Trane Installed	Field Installed	
Foundation			<ul style="list-style-type: none"> <li>• Meet foundation requirements</li> </ul>
Rigging			<ul style="list-style-type: none"> <li>• Safety chains</li> <li>• Clevis connectors</li> <li>• Lifting beam</li> </ul>
Isolation		<ul style="list-style-type: none"> <li>• Isolation pads or neoprene isolators (opt)</li> </ul>	<ul style="list-style-type: none"> <li>• Isolation pads or neoprene isolators (optional)</li> </ul>
Electrical	<ul style="list-style-type: none"> <li>• Circuit breakers or fusible disconnects (optional)</li> <li>• Unit mounted starter</li> </ul>	<ul style="list-style-type: none"> <li>• Flow switches (may be field supplied)</li> <li>• Water regulating valve (optional)</li> </ul>	<ul style="list-style-type: none"> <li>• Circuit breakers or fusible disconnects (opt)</li> <li>• Electrical connections to unit mounted starter (opt)</li> <li>• Electrical connections to remote mounted starter (opt)</li> <li>• Wiring sizes per submittal and NEC</li> <li>• Terminal lugs</li> <li>• Ground connection(s)</li> <li>• BAS wiring (opt)</li> <li>• Control voltage wiring</li> <li>• Chilled water pump contactor and wiring including interlock</li> <li>• Condenser water pump contactor and wiring including interlock</li> <li>• Option relays and wiring</li> </ul>
Water piping	<ul style="list-style-type: none"> <li>• Flow switches (optional)</li> </ul>	<ul style="list-style-type: none"> <li>• Flow switches (may be field supplied)</li> <li>• Water regulating valve (optional)</li> </ul>	<ul style="list-style-type: none"> <li>• Taps for thermometers and gauges</li> <li>• Thermometers</li> <li>• Strainers (as required)</li> <li>• Water flow pressure gauges</li> <li>• Isolation and balancing valves in water piping</li> <li>• Vents and drain on waterbox valves</li> <li>• Pressure relief valves (for waterboxes as required)</li> </ul>
Relief	<ul style="list-style-type: none"> <li>• Single relief valve</li> <li>• Dual relief valves (opt)</li> </ul>		<ul style="list-style-type: none"> <li>• Vent line and flexible connector and vent line from relief valve to atmosphere</li> </ul>
Insulation	<ul style="list-style-type: none"> <li>• Insulation</li> <li>• High humidity insulation (opt)</li> </ul>		<ul style="list-style-type: none"> <li>• Insulation</li> </ul>
Water Piping Connection Components	<ul style="list-style-type: none"> <li>• Grooved pipe</li> <li>• Grooved pipe to flanged connection (opt)</li> </ul>		
Other Materials			<ul style="list-style-type: none"> <li>• R-134a refrigerant (1 lb. max per machine as needed)</li> <li>• Dry nitrogen (20 psig max per machine as needed)</li> </ul>



# Unit Dimensions/Weights

## Service Clearances and Dimension

Figure 4. RTWD/RTUD – 60 Hz dimensions – 80-140 ton

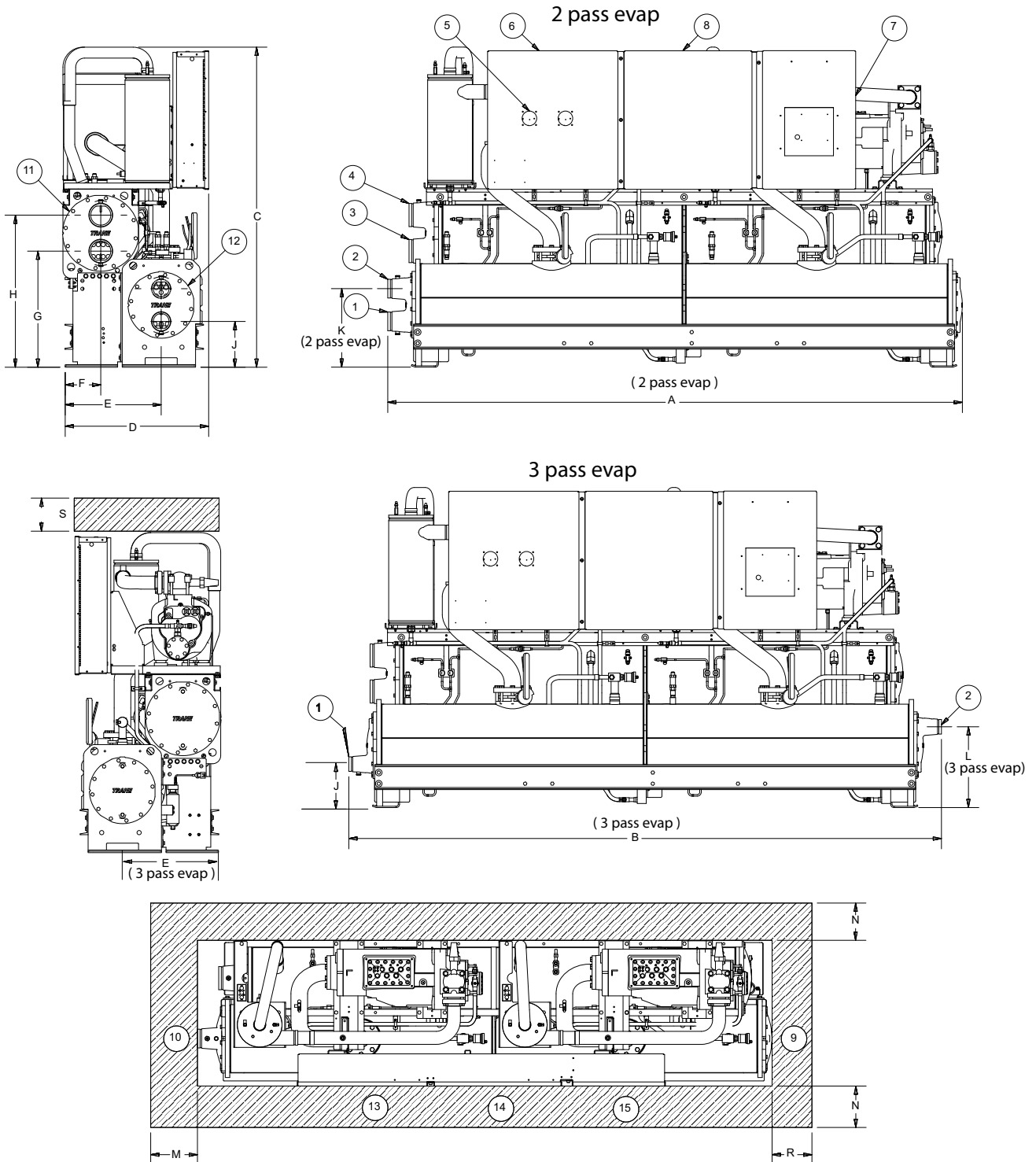

## Unit Dimensions/Weights

Table 10. RTWD/RTUD – 60 Hz dimensions – 80-140 ton

	Standard Efficiency			RTWD/RTUD - High Efficiency	
	80,90 inch (mm)	100,110 inch (mm)	120,130,140 inch (mm)	80,90 inch (mm)	100,110,120,130 inch (mm)
<b>A (2 pass evap)</b>	138.2 (3510)	138.2 (3510)	138.8 (3525)	126.4 (3210)	126.9 (3225)
<b>B (3 pass evap)</b>	142.6 (3621)	142.6 (3621)	142.6 (3621)	130.8 (3321)	130.7 (3320)
<b>C</b>	75.9 (1929)	76.9 (1955)	76.9 (1955)	76.1 (1933)	76.9 (1955)
<b>D</b>	34.3 (871)	34.3 (871)	34.8 (884)	35.1 (890)	35.1 (890)
<b>E</b>	23.6 (600)	23.6 (600)	23.6 (600)	23.6 (600)	23.6 (600)
<b>F</b>	9.1 (231)	9.1 (231)	9.1 (231)	9.1 (231)	9.1 (231)
<b>G</b>	27.9 (709)	27.9 (709)	27.9 (709)	27.9 (709)	27.9 (709)
<b>H</b>	36.6 (929)	36.6 (929)	36.6 (929)	36.6 (929)	36.6 (929)
<b>J (2 pass evap)</b>	11.0 (280)	11.0 (280)	10.6 (268)	10.8 (273)	11.8 (299)
<b>J (3 pass evap)</b>	10.4 (265)	10.4 (265)	10.1 (256)	10.2 (258)	11.3 (287)
<b>K (2 pass evap)</b>	18.9 (479)	18.9 (479)	19.2 (487)	18.6 (472)	20.4 (519)
<b>L (3 pass evap)</b>	19.5 (495)	19.5 (495)	19.5 (496)	19.2 (488)	19.2 (487)
<b>M</b>	36 (914)	36 (914)	36 (914)	36 (914)	36 (914)
<b>N*</b>	36 (914)*	36 (914)*	36 (914)*	36 (914)*	36 (914)*
<b>R</b>	127 (3226)	127 (3226)	127 (3226)	115 (2921)	115 (2921)
<b>S</b>	36 (914)	36 (914)	36 (914)	36 (914)	36 (914)

### Reference

<b>1</b>	Evaporator Water Inlet
<b>2</b>	Evaporator Water Outlet
<b>3</b>	Condenser Water Inlet (RTWD only)
<b>4</b>	Condenser Water Outlet (RTWD only)
<b>5</b>	Power Disconnect
<b>6</b>	Power Wire
<b>7</b>	Control Wire
<b>8</b>	Control Panel
<b>9</b>	Condenser Return Waterbox End (RTWD only) - minimum clearance (for tube removal)
<b>10</b>	Condenser Supply Waterbox End (RTWD only) - minimum clearance (for maintenance)
<b>11</b>	Condenser (RTWD only)
<b>12</b>	Evaporator
<b>13</b>	Panel Power Section - door swing 31.3 inch (796.9 mm)
<b>14</b>	Panel Power Section - door swing 31.1 inch (790.1 mm)
<b>15</b>	Panel Control Section - door swing 22.4 inch (568.14 mm)
*	42 inch (1067 mm) clearance required to other ground parts, two units with panels facing each other or other live parts require a clearance of 48 inch (1220 mm)
**	Sound attenuator may increase the footprint - submittal should be used.

# Unit Dimensions/Weights

Figure 5. RTWD/RTUD – 60 Hz dimensions – 150-250 tons

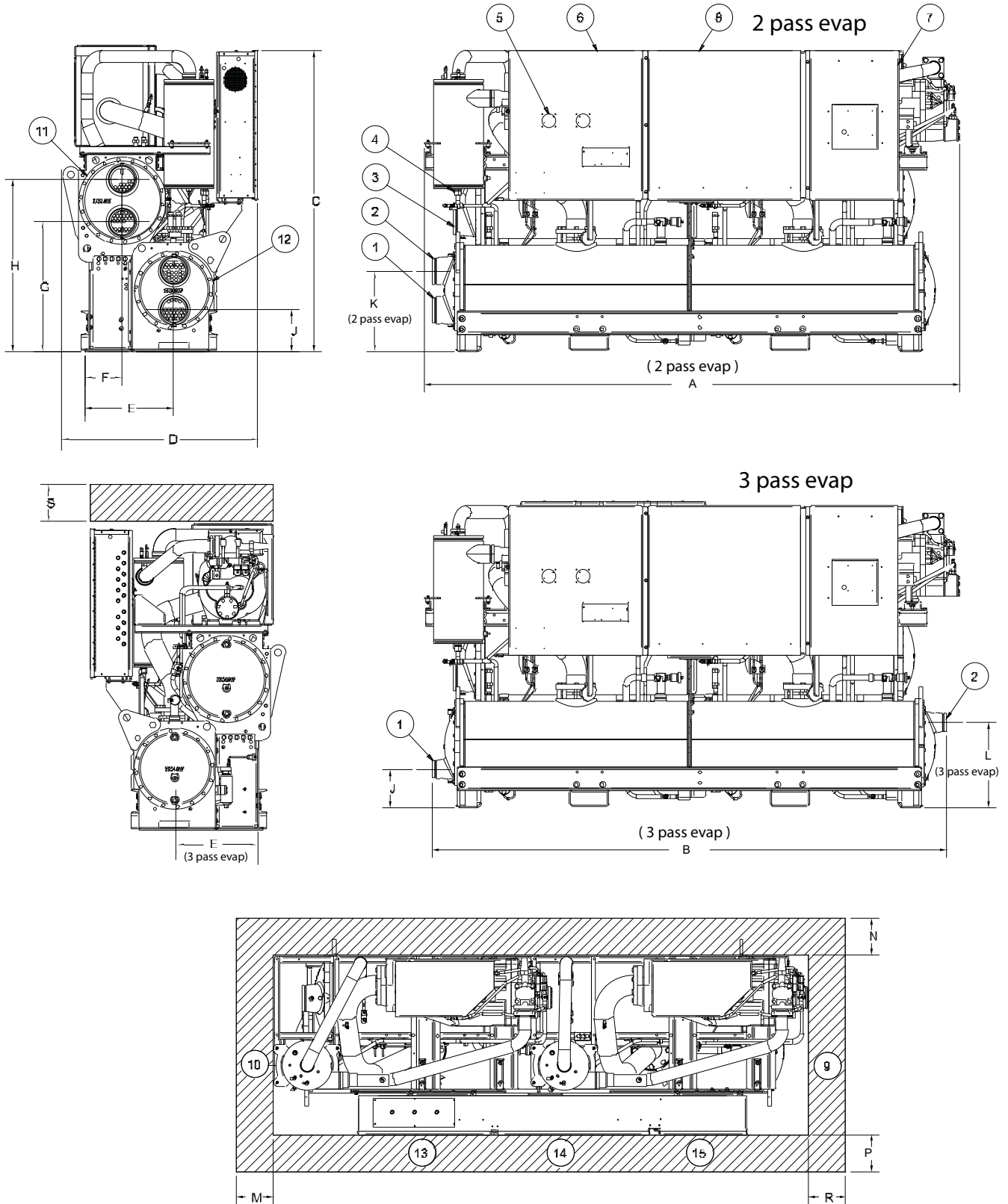

## Unit Dimensions/Weights

Table 11. RTWD/RTUD – 60 Hz dimensions – 150-250 tons

	RTWD			RTUD		
	High Efficiency		Prem Efficiency	150 inch (mm)	160-200 inch (mm)	220,250 inch (mm)
	150-200 inch (mm)	220, 250 inch (mm)	150-200 inch (mm)			
<b>A (2 pass evap)</b>	132.3 (3360)	136.1 (3456)	147.9 (3755)	126.9 (3225)	132.3 (3360)	132.3 (3360)
<b>B (3 pass evap)</b>	132.8 (3371)	136.1 (3456)	150.9 (3831)	130.8 (3321)	132.8 (3371)	132.9 (3376)
<b>C</b>	75.6 (1920)	76.9 (1955)	76.8 (1950)	76.9 (1955)	75.6 (1920)	76.7 (1949)
<b>D</b>	47.3 (1202)	47.8 (1213)	47.3 (1202)	37.9 (962)	47.4 (1203)	47.4 (1203)
<b>E</b>	24.6 (624)	24.8 (630)	24.6 (624)	23.5 (599)	24.5 (624)	24.6 (624)
<b>F</b>	11.1 (282)	11.2 (295)	11.1 (282)	-	-	-
<b>G</b>	32.7 (830)	33.1 (840)	33.8 (860)	-	-	-
<b>H</b>	42.4 (1078)	43.9 (1115)	43.6 (1108)	-	-	-
<b>J (2 pass evap)</b>	10.1 (256)	10.6 (270)	10.6 (270)	10.2/259	10.1 (256)	11.3 (263)
<b>J (3 pass evap)</b>	9.5 (241)	9.7 (247)	9.7 (247)	9.8/247	9.5 (241)	8.8 (223)
<b>K (2 pass evap)</b>	19.3 (490)	20.6 (524)	20.6 (524)	18.9/479	19.3 (490)	19.9 (483)
<b>L (3 pass evap)</b>	19.9 (505)	21.6 (549)	21.6 (549)	19.8/501	19.9 (505)	20.7 (526)
<b>M</b>	36.0 (914)	36.0 (914)	36.0 (914)	36.0 (914)	36.0 (914)	36.0 (914)
<b>N</b>	36.0 (914)	36.0 (914)	36.0 (914)	36.0 (914)	36.0 (914)	36.0 (914)
<b>P*</b>	40 (1016)*	40 (1016)*	40 (1016)*	40 (1016)*	40 (1016)*	40 (1016)*
<b>R</b>	114.8 (2916)	114.8 (2916)	134.5 (3416)	114.8 (2916)	114.8 (2916)	114.8 (2916)
<b>S</b>	36.0 (914)	36.0 (914)	36.0 (914)	36.0 (914)	36.0 (914)	36.0 (914)

### Reference

<b>1</b>	Evaporator Water Inlet
<b>2</b>	Evaporator Water Outlet
<b>3</b>	Condenser Water Inlet (RTWD only)
<b>4</b>	Condenser Water Outlet (RTWD only)
<b>5</b>	Power Disconnect
<b>6</b>	Power Wire
<b>7</b>	Control Wire
<b>8</b>	Control Panel
<b>9</b>	Condenser Return Waterbox End (RTWD only) - minimum clearance (for tube removal)
<b>10</b>	Condenser Supply Waterbox End (RTWD only) - minimum clearance (for maintenance)
<b>11</b>	Condenser (RTWD only)
<b>12</b>	Evaporator
<b>13</b>	Panel Power Section - door swing 31.3 inch (796.9 mm)
<b>14</b>	Panel Power Section - door swing 31.1 inch (790.1 mm)
<b>15</b>	Panel Control Section - door swing 22.4 inch (568.14 mm)
*	Control panel clearance is 36 or 40 inch (914 or 1016 mm) depending on voltages, starter type, unit application and local code; 42 inch (1067 mm) clearance required to other grounded parts; two units with panels facing each other or other live parts require a clearance of 48 inch (1220 mm).
**	Sound attenuator may increase the footprint - submittal should be used.

**Figure 6. RTWD - 50 Hz dimensions - 70-150 ton SE, 60-120 ton HE**

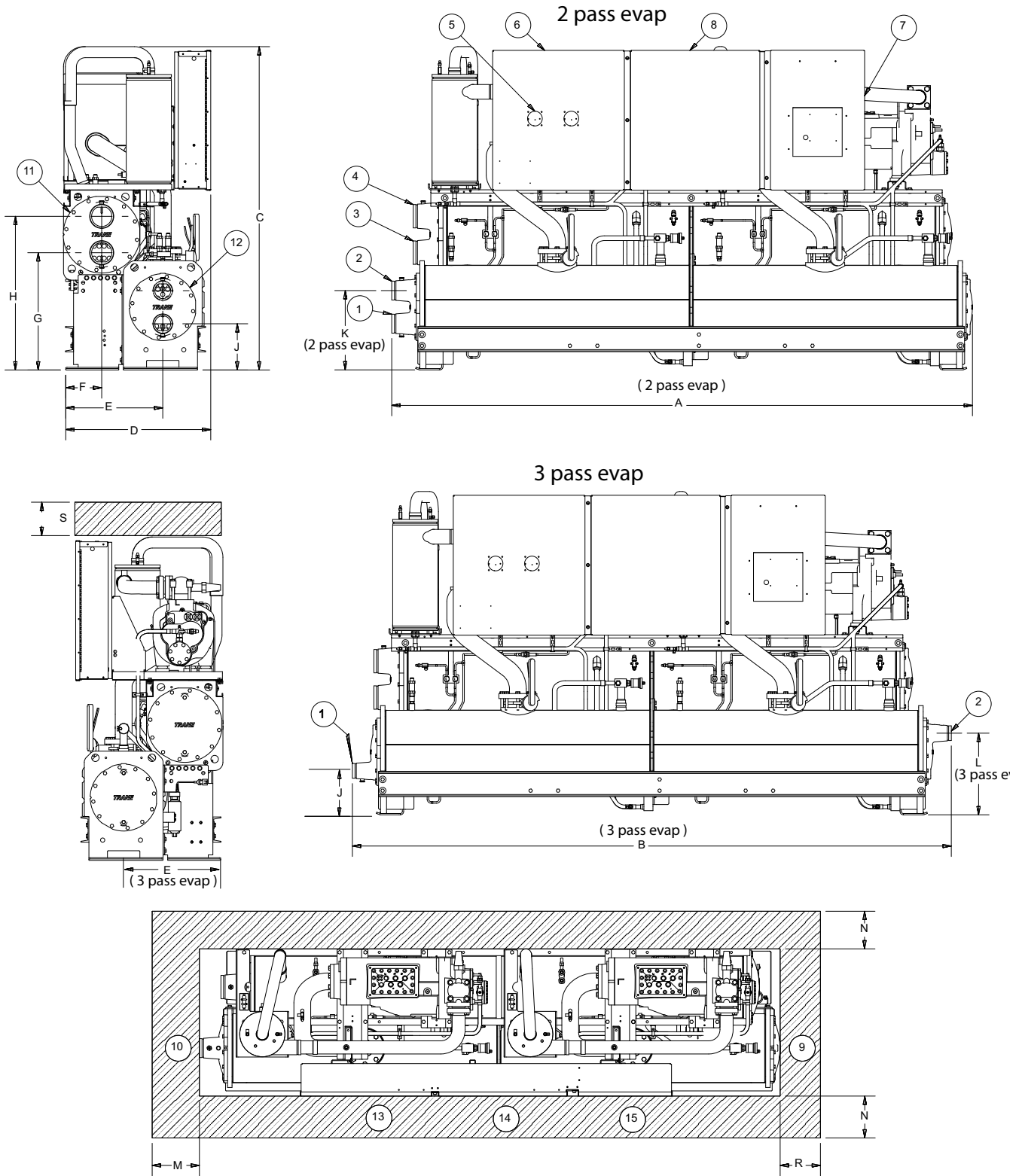

## Unit Dimensions/Weights

Table 12. RTWD – 50 Hz – 70-150 ton SE, 60-120 ton HE

RTWD	Standard Efficiency		High Efficiency		
	70,80,90,100,110 inch (mm)	120,130,140,150 inch (mm)	60,70,80 inch (mm)	90 inch (mm)	100,110,120 inch (mm)
<b>A (2 pass evap)</b>	138.2 (3510)	138.8 (3525)	126.4 (3210)	127.0 (3225)	127.0 (3225)
<b>B (3 pass evap)</b>	142.6 (3621)	145.6 (3621)	130.8 (3321)	130.7 (3320)	130.7 (3320)
<b>C</b>	75.9 (1929)	76.9 (1955)	76.1 (1933)	76.1 (1933)	76.9 (1955)
<b>D</b>	34.3 (871)	34.8 (884)	35.1 (890)	35.1 (890)	35.1 (890)
<b>E</b>	23.6 (600)	23.6 (600)	23.6 (600)	23.6 (600)	23.6 (600)
<b>F</b>	9.1 (231)	9.1 (231)	9.1 (231)	9.1 (231)	9.1 (231)
<b>G</b>	27.9 (709)	27.9 (709)	27.9 (709)	27.9 (709)	27.9 (709)
<b>H</b>	36.6 (929)	36.6 (929)	36.6 (929)	36.6 (929)	36.6 (929)
<b>J (2 pass evap)</b>	11.0 (280)	10.6 (268)	10.8 (273)	11.8 (299)	11.8 (299)
<b>J (3 pass evap)</b>	10.4 (265)	10.1 (256)	10.2 (258)	11.3 (287)	11.3 (287)
<b>K (2 pass evap)</b>	18.9 (479)	19.2 (487)	18.6 (472)	20.4 (519)	20.4 (519)
<b>L (3 pass evap)</b>	19.5 (495)	19.5 (496)	19.2 (488)	19.2 (487)	19.2 (487)
<b>M</b>	36 (914)	36 (914)	36 (914)	36 (914)	36 (914)
<b>N*</b>	36 (914)*	36 (914)*	36 (914)*	36 (914)*	36 (914)*
<b>R</b>	127 (3226)	127 (3226)	115 (2921)	115 (2921)	115 (2921)
<b>S</b>	36 (914)	36 (914)	36 (914)	36 (914)	36 (914)

### Reference

<b>1</b>	Evaporator Water Inlet
<b>2</b>	Evaporator Water Outlet
<b>3</b>	Condenser Water Inlet
<b>4</b>	Condenser Water Outlet
<b>5</b>	Power Disconnect
<b>6</b>	Power Wire
<b>7</b>	Control Wire
<b>8</b>	Control Panel
<b>9</b>	Condenser Return Waterbox End - minimum clearance (for tube removal)
<b>10</b>	Condenser Supply Waterbox End - minimum clearance (for maintenance)
<b>11</b>	Condenser
<b>12</b>	Evaporator
<b>13</b>	Panel Power Section - door swing 31.3 inch (796.9 mm)
<b>14</b>	Panel Power Section - door swing 31.1 inch (790.1 mm)
<b>15</b>	Panel Control Section - door swing 22.4 inch (568.14 mm)
*	42 inch (1067 mm) clearance required to other ground parts, two units with panels facing each other or other live parts require a clearance of 48 inch (1220 mm)
**	Sound attenuator may increase the footprint - submittal should be used.

# Unit Dimensions/Weights

Figure 7. RTWD - 50 Hz dimensions - 130-250 ton HE, 160-200 ton PE

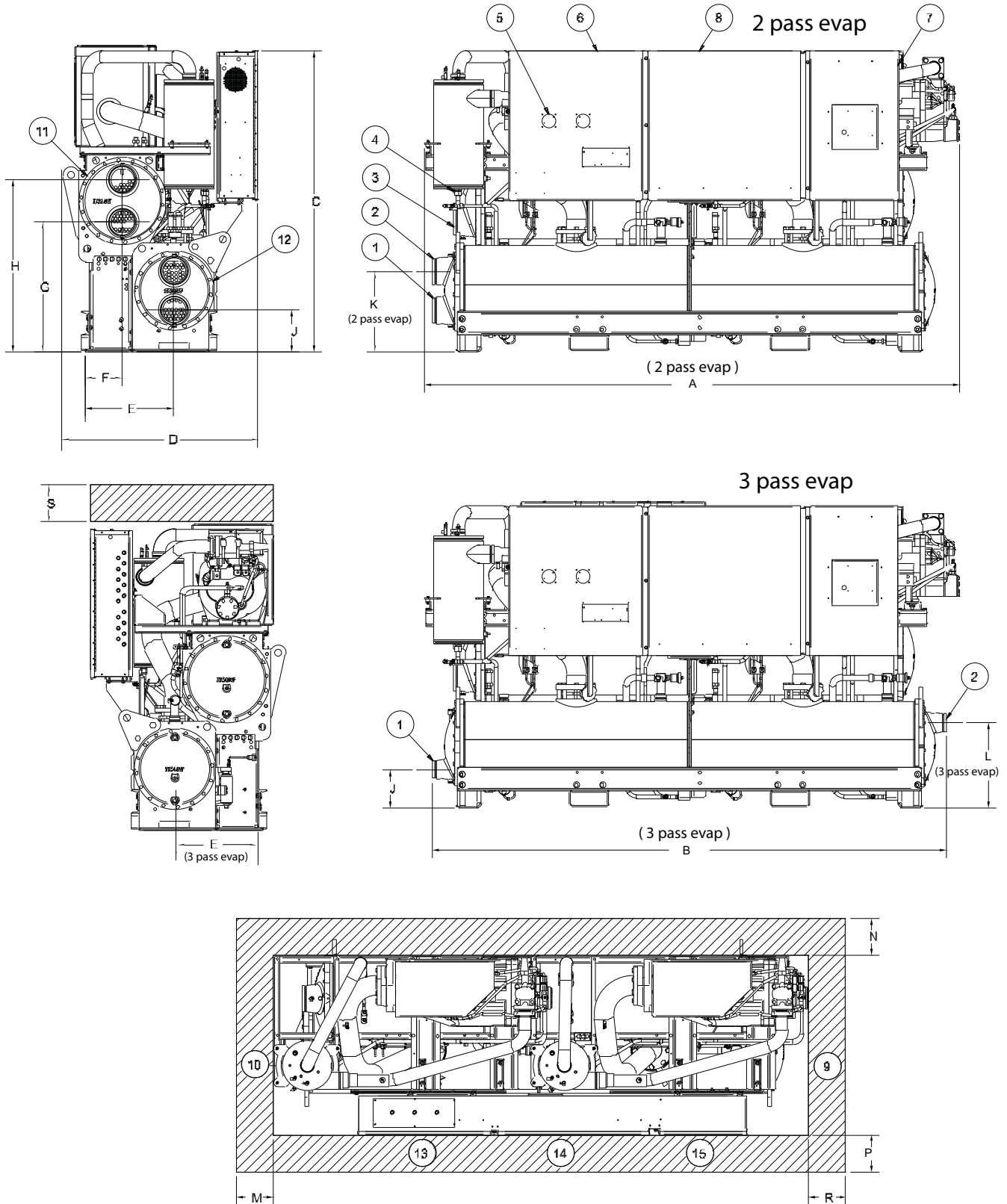



## Unit Dimensions/Weights

Table 13. RTWD – 50 Hz dimensions – 130-250 ton HE, 160-200 ton PE

RTWD	High Efficiency		Premium Efficiency	
	130, 140, 160, 180 inch (mm)	200, 220, 250 inch (mm)	160, 180 inch (mm)	200 inch (mm)
<b>A (2 pass evap)</b>	132.3 (3360)	136.1 (3456)	147.9 (3755)	136.1 (3456)
<b>B (3 pass evap)</b>	132.8 (3371)	136.1 (3456)	150.8 (3831)	136.1 (3456)
<b>C</b>	75.6 (1920)	76.8 (1949)	76.8 (1950)	76.9 (1955)
<b>D</b>	47.3 (1202)	47.8 (1213)	47.3 (1202)	47.8 (1213)
<b>E</b>	24.6 (624)	24.8 (630)	24.6 (624)	24.8 (630)
<b>F</b>	11.1 (282)	11.6 (295)	11.1 (282)	11.6 (295)
<b>G</b>	32.7 (830)	33.1 (840)	33.8 (860)	33.1 (840)
<b>H</b>	42.4 (1078)	43.9 (1115)	43.6 (1108)	43.9 (1115)
<b>J (2 pass evap)</b>	10.1 (256)	10.6 (270)	10.6 (270)	10.6 (270)
<b>J (3 pass evap)</b>	9.5 (241)	9.7 (247)	9.7 (247)	9.7 (247)
<b>K (2 pass evap)</b>	19.3 (490)	20.6 (524)	20.6 (524)	20.6 (524)
<b>L (3 pass evap)</b>	19.9 (505)	21.6 (549)	21.6 (550)	21.6 (549)
<b>M</b>	36.0 (914)	36.0 (914)	36.0 (914)	36.0 (914)
<b>N</b>	36.0 (914)	36.0 (914)	36.0 (914)	36.0 (914)
<b>P*</b>	40 (1016)*	40 (1016)*	40 (1016)*	40 (1016)*
<b>R</b>	114.8 (2916)	114.8 (2916)	134.5 (3416)	134.5 (3416)
<b>S</b>	36.0 (914)	36.0 (914)	36.0 (914)	36.0 (914)

### Reference

<b>1</b>	Evaporator Water Inlet
<b>2</b>	Evaporator Water Outlet
<b>3</b>	Condenser Water Inlet
<b>4</b>	Condenser Water Outlet
<b>5</b>	Power Disconnect
<b>6</b>	Power Wire
<b>7</b>	Control Wire
<b>8</b>	Control Panel
<b>9</b>	Condenser Return Waterbox End - minimum clearance (for tube removal)
<b>10</b>	Condenser Supply Waterbox End - minimum clearance (for maintenance)
<b>11</b>	Condenser
<b>12</b>	Evaporator
<b>13</b>	Panel Power Section - door swing 31.3 inch (796.9 mm)
<b>14</b>	Panel Power Section - door swing 31.1 inch (790.1 mm)
<b>15</b>	Panel Control Section - door swing 22.4 inch (568.14 mm)
*	Control panel clearance is 36 or 40 inch (914 or 1016 mm) depending on voltages, starter type, unit application and local code; 42 inch (1067 mm) clearance required to other grounded parts; two units with panels facing each other or other live parts require a clearance of 48 inch (1220 mm).
**	Sound attenuator may increase the footprint - submittal should be used.

## Unit Dimensions/Weights

Figure 8. RTWD/RTUD Unit footprint

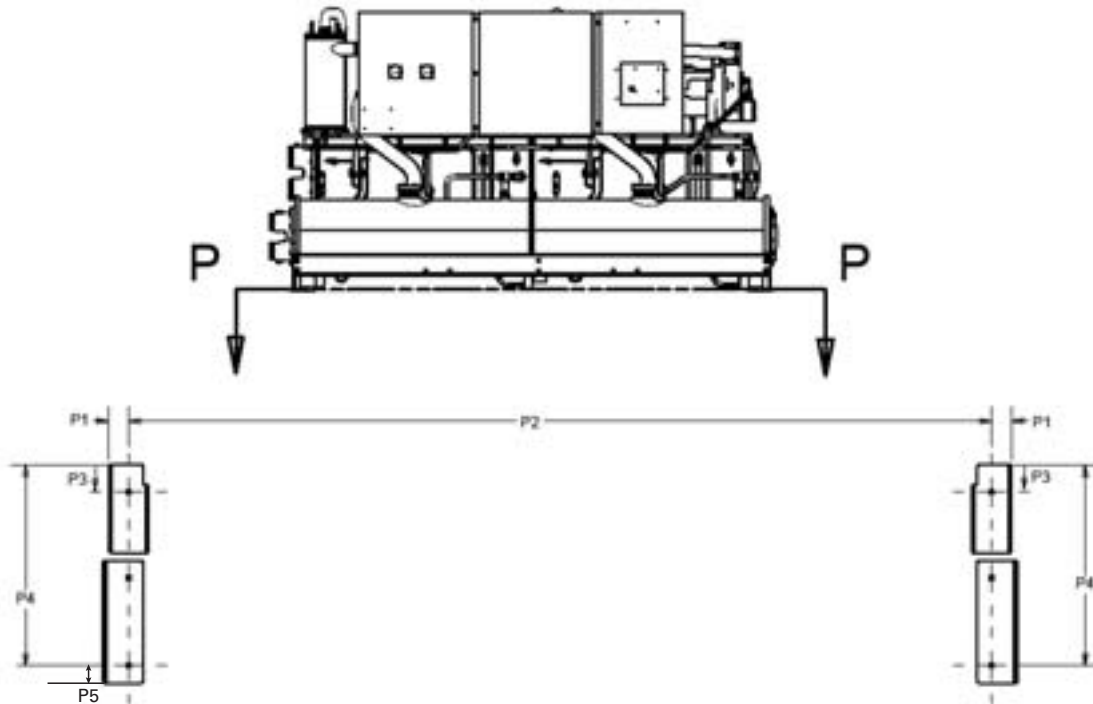

Table 14. RTWD/RTUD – unit footprint – all sizes

	Standard Efficiency	High Efficiency 200 PE (50 Hz)	Premium Efficiency
	inch (mm)	inch (mm)	inch (mm)
<b>P1</b>	3.68 (93.5)	3.68 (93.5)	3.68 (93.5)
<b>P2</b>	123.78 (3144)	111.97 (2844)	131.65 (3344)
<b>P3</b>	2.43 (61.8)	4.30 (109.3)	4.30 (109.3)
<b>P4</b>	24.93 (633.2)	24.93 (633.2)	24.93 (633.2)
<b>P5</b>	2.5 (64)	2.5 (64)	2.5 (64)

Note: Base hole diameters all 0.63 inch (16 mm).

## Unit Dimensions/Weights

**Figure 9. Trane air-cooled condenser - 80T, 150T (cond 1 & 2), 160T (cond 1 & 2), 180T (cond 1)**

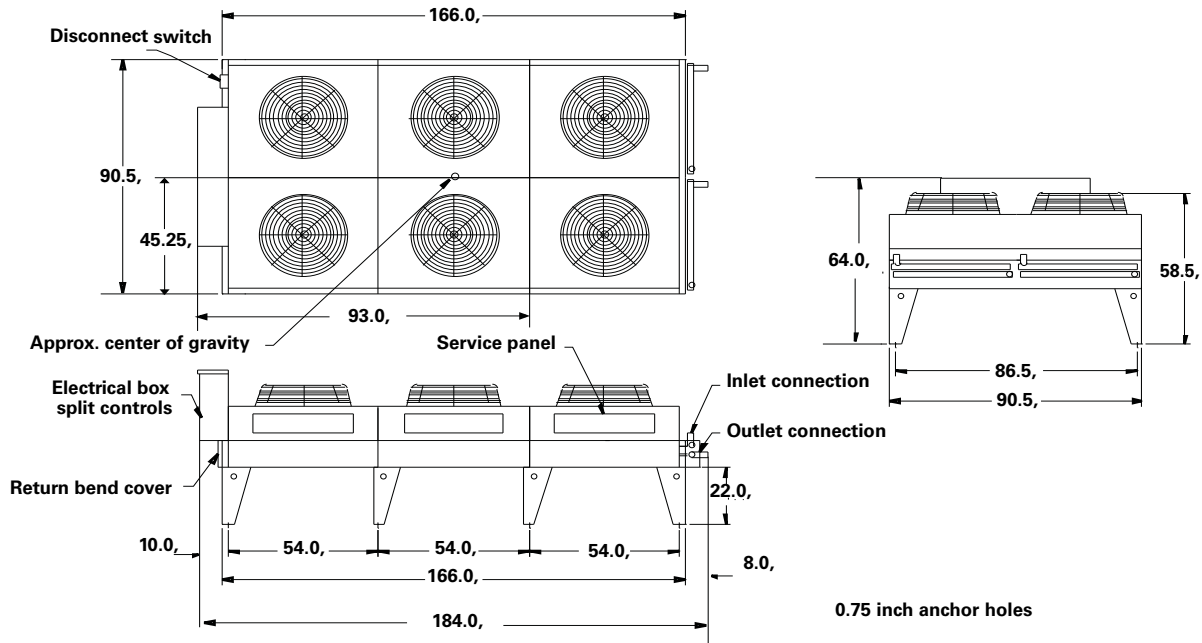

**Figure 10. Trane air-cooled condenser - 90T, 100T, 110T, 180T (cond 2), 200T (cond 1 & 2), 220T (cond 1 & 2), 250T (cond 1 & 2)**

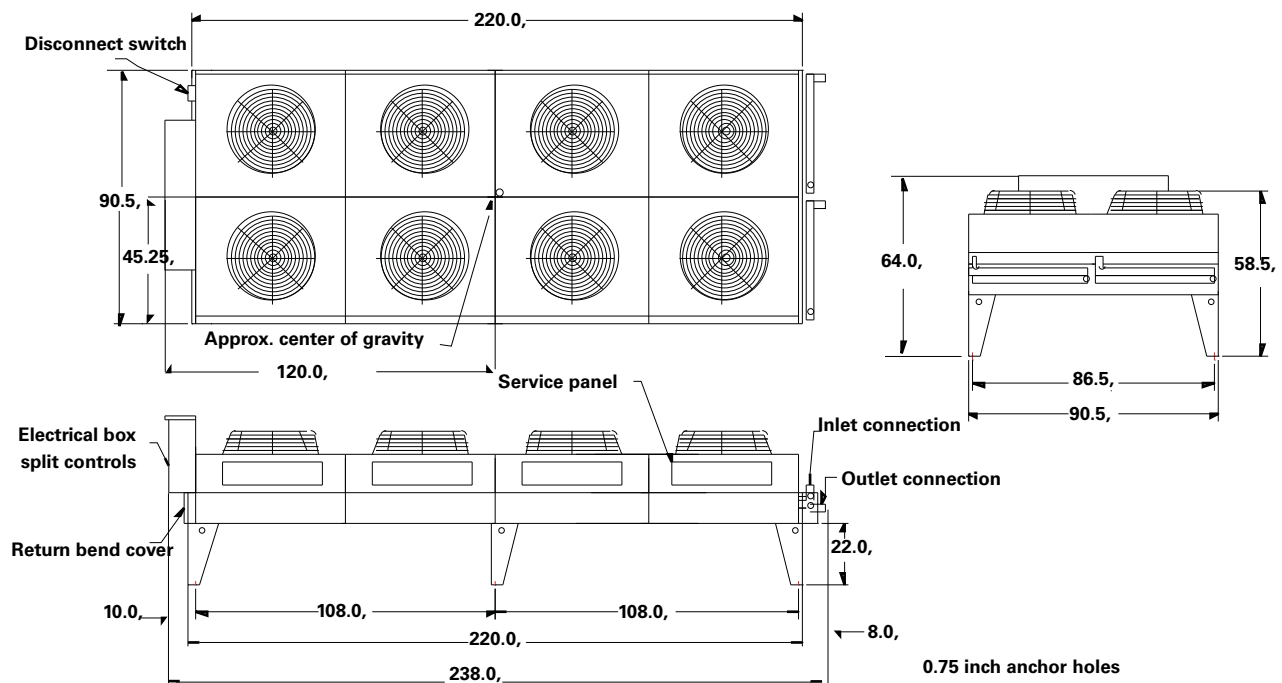



## Unit Dimensions/Weights

Figure 11. Trane air-cooled condenser - 120T, 130T

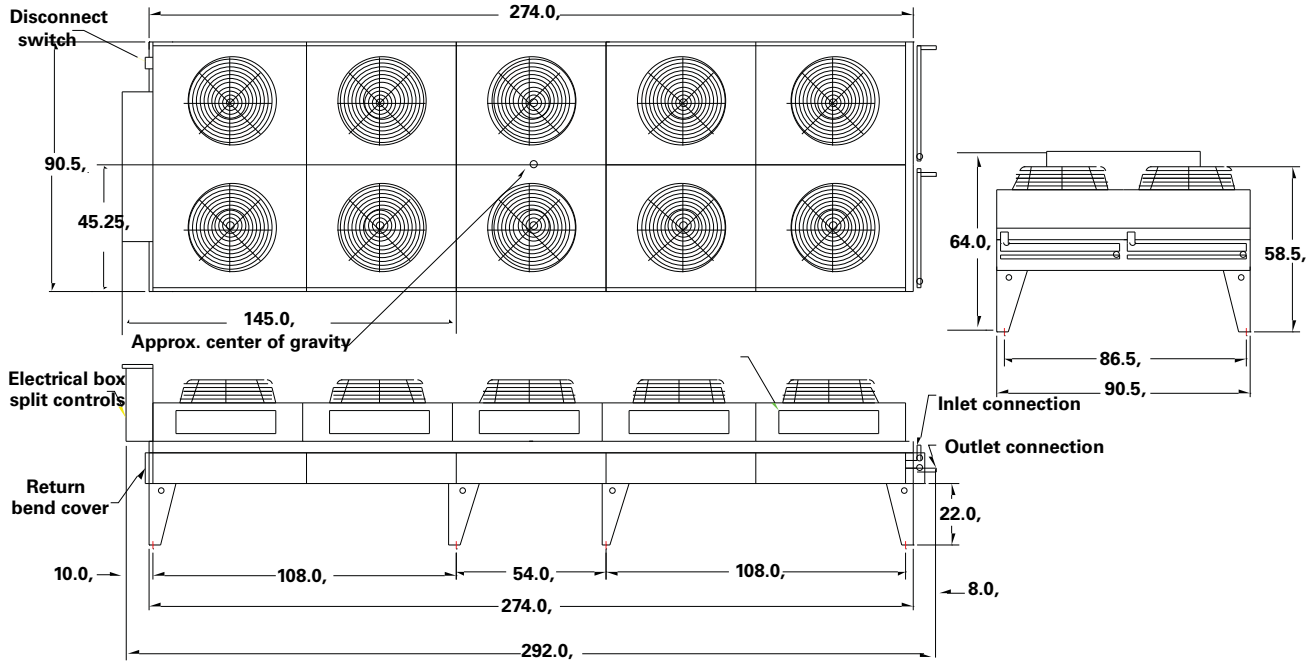

## Weights

Table 15. Weights - RTWD 60 Hz - IP units

Model	Standard Efficiency		High Efficiency		Premium Efficiency	
	Operating (lb)	Shipping (lb)	Operating (lb)	Shipping (lb)	Operating (lb)	Shipping (lb)
80	5900	5703	5732	5551	-	-
90	5933	5721	5792	5587	-	-
100	6140	5902	6255	6025	-	-
110	6332	6074	6475	6208	-	-
120	6530	6248	6510	6230	-	-
130	6535	6244	6543	6248	-	-
140	6971	6649	-	-	-	-
150	-	-	7884	7544	8724	8243
160	-	-	8395	8036	9171	8691
180	-	-	8490	8098	9290	8772
200	-	-	8578	8157	9337	8803
220	-	-	9493	8995	-	-
250	-	-	10071	9478	-	-

Note: Weights include optional base rail forklifting. Subtract 300 lbs if this option is not selected.

## Unit Dimensions/Weights

**Table 16. Weights - RTWD 60 Hz - SI units**

Model	Standard Efficiency		High Efficiency		Premium Efficiency	
	Operating (kg)	Shipping (kg)	Operating (kg)	Shipping (kg)	Operating (kg)	Shipping (kg)
80	2676	2587	2600	2518	-	-
90	2691	2595	2627	2534	-	-
100	2785	2677	2837	2733	-	-
110	2872	2755	2937	2816	-	-
120	2962	2834	2953	2826	-	-
130	2964	2832	2968	2834	-	-
140	3162	3016	-	-	-	-
150	-	-	3576	3422	3957	3739
160	-	-	3808	3645	4160	3942
180	-	-	3851	3673	4214	3979
200	-	-	3891	3700	4235	3993
220	-	-	4306	4080	-	-
250	-	-	4568	4299	-	-

**Note:** Weights include optional base rail forklifting. Subtract 136.1 kg if this option is not selected.

**Table 17. Weights - RTUD - 60 Hz**

Model	IP units (lbs)		SI units (kg)	
	Operating	Shipping	Operating	Shipping
80	4874	4793	2211	2174
90	4892	4804	2219	2179
100	5073	4974	2301	2256
110	5326	5221	2416	2368
120	5322	5194	2414	2356
130	5322	5194	2414	2356
150	5917	5781	2684	2622
160	6804	6643	3086	3013
180	6876	6715	3119	3046
200	6980	6810	3166	3089
220	7300	7112	3311	3226
250	7602	7401	3448	3357

**Note:** Weights include optional base rail forklifting. Subtract 300 lbs if this option is not selected.

**Table 18. Air-Cooled Condenser Weights**

RTUD Tonnage	I-P Units (lbs)		SI Units (kg)	
	Shipping Weight		Shipping Weight	
	Cond 1	Cond 2	Cond 1	Cond 2
80	2100	-	953	-
90	2651	-	1202	-
100	2884	-	1308	-
110	2950	-	1338	-
120	4005	-	1817	-
130	4046	-	1835	-
150	2044	2100	927	953
160	2100	2100	953	953
180	2100	2526	953	1146
200	2526	2526	1146	1146
220	2526	2884	1146	1308
250	2884	2884	1308	1308



## Unit Dimensions/Weights

**Table 19. Weights - RTWD 50 Hz - IP units**

Model	Standard Efficiency		High Efficiency		Premium Efficiency	
	Operating (lb)	Shipping (lb)	Operating (lb)	Shipping (lb)	Operating (lb)	Shipping (lb)
60	-	-	5706	5525	-	-
70	5874	5677	5724	5534	-	-
80	6030	5807	5893	5680	-	-
90	6187	5938	6319	6063	-	-
100	6268	6010	6412	6145	-	-
110	6332	6014	6495	6220	-	-
120	6903	6614	6914	6619	-	-
130	7337	7016	8177	7837	-	-
140	7342	7020	8245	7884	-	-
150	7395	7049	N/A	N/A	-	-
160	-	-	8342	7950	9061	8565
180	-	-	8770	8351	9579	9030
200	-	-	9758	9259	10060	9467
220	-	-	9793	9284	-	-
250	-	-	9958	9398	-	-

**Note:** All weights +/-3%. Weights include optional base rail forklifting. Subtract 300 lbs if this option is not selected.

**Table 20. Weights - RTWD 50 Hz - SI units**

Model	Standard Efficiency		High Efficiency		Premium Efficiency	
	Operating (kg)	Shipping (kg)	Operating (kg)	Shipping (kg)	Operating (kg)	Shipping (kg)
60	-	-	2588	2506	-	-
70	2664	2575	2596	2510	-	-
80	2735	2634	2673	2576	-	-
90	2806	2693	2866	2750	-	-
100	2843	2726	2908	2787	-	-
110	2872	2755	2946	2821	-	-
120	3131	3000	3136	3002	-	-
130	3328	3182	3709	3555	-	-
140	3330	3184	3740	3576	-	-
150	3354	3197	-	-	-	-
160	-	-	3784	3606	4110	3885
180	-	-	3979	3788	4345	4096
200	-	-	4426	4200	4563	4294
220	-	-	4442	4211	-	-
250	-	-	4517	4263	-	-

**Note:** Weights include optional base rail forklifting. Subtract 136.1 kg if this option is not selected.

# Installation - Mechanical

## Location Requirements

### Noise Considerations

- Refer to Trane Engineering Bulletin -Series R<sup>®</sup> Chiller Sound Ratings and Installation Guide for sound consideration applications.
- Locate the unit away from sound-sensitive areas.
- Install the isolation pads under the unit. Refer to “Unit Isolation.”
- Install rubber vibration isolators in all water piping.
- Seal all wall penetrations.

Note: Consult an acoustical engineer for critical applications.

### Foundation

Provide rigid, non-warping mounting pads or a concrete foundation of sufficient strength and mass to support the applicable operating weight (i.e., including completed piping, and full operating charges of refrigerant, oil and water). See “Unit Dimensions/Weights” chapter for unit operating weights. Once in place, the unit must be level within 1/4” (6.4 mm) over its length and width. The Trane Company is not responsible for equipment problems resulting from an improperly designed or constructed foundation.

### Clearances

Provide enough space around the unit to allow the installation and maintenance personnel unrestricted access to all service points. Refer to submittal drawings for the unit dimensions, to provide sufficient clearance for the opening of control panel doors and unit service. Refer to the chapter on “Unit Dimensions/Weights” for minimum clearances. In all cases, local codes which require additional clearances will take precedence over these recommendations.

Note: Required vertical clearance above the unit is 36” (914.4 mm). There should be no piping or conduit located over the compressor motor. If the unit configuration requires a variance to the clearance dimensions, contact your Trane Sales Office Representative. Also refer to Trane Engineering Bulletins for application information on RTWD/RTUD chillers.

### Rigging

The Model RTWD/RTUD chiller should be moved by lifting, unless the unit is ordered with the “Base Rail Forklifting” option. Refer to the unit model number, digit 46, for more details.

Refer to [Table 15, p. 28](#) thru [Table 20, p. 30](#) for typical unit lifting weights and [Table 30, p. 39](#) thru [Table 35, p. 40](#) for

center of gravity dimensions. Refer to the rigging label attached to the unit for further details.\

### **⚠ WARNING**

#### **Heavy Objects!**

- Ensure that all the lifting equipment used is properly rated for the weight of the unit being lifted. Each of the cables (chains or slings), hooks, and shackles used to lift the unit must be capable of supporting the entire weight of the unit.
- Lifting cables (chains or slings) may not be of the same length. Adjust as necessary for even unit lift.
- The high center of gravity on this unit requires the use of an anti-rolling cable (chain or sling). To prevent unit from rolling, attach cable (chain or sling) with no tension and minimal slack around compressor suction pipe as shown.
- Do not use fork lift to move or lift unit unless unit has lifting base with locations marked by caution labels installed.

Other lifting arrangements could cause equipment or property damage. Failure to follow instructions above or properly lift unit could result in unit dropping and possibly crushing operator/technician which could result in death or serious injury.

### **⚠ WARNING**

#### **Improper Unit Lift!**

Test lift unit approximately 24 inches to verify proper center of gravity lift point. To avoid dropping of unit, reposition lifting point if unit is not level. Failure to properly lift unit could result in unit dropping and possibly crushing operator/technician which could result in death or serious injury and possible equipment or property-only damage.

### Lifting Procedure

Attach chains or cables to lifting beam, as shown in [Figure](#) .Lifting beam crossbars MUST be positioned so lifting cables do not contact the sides of the unit. Attach the anti-rolling cable to the circuit 2 compressor suction pipe. Adjust as necessary for even level lift.

**Figure 12. RTWD/RTUD rigging**

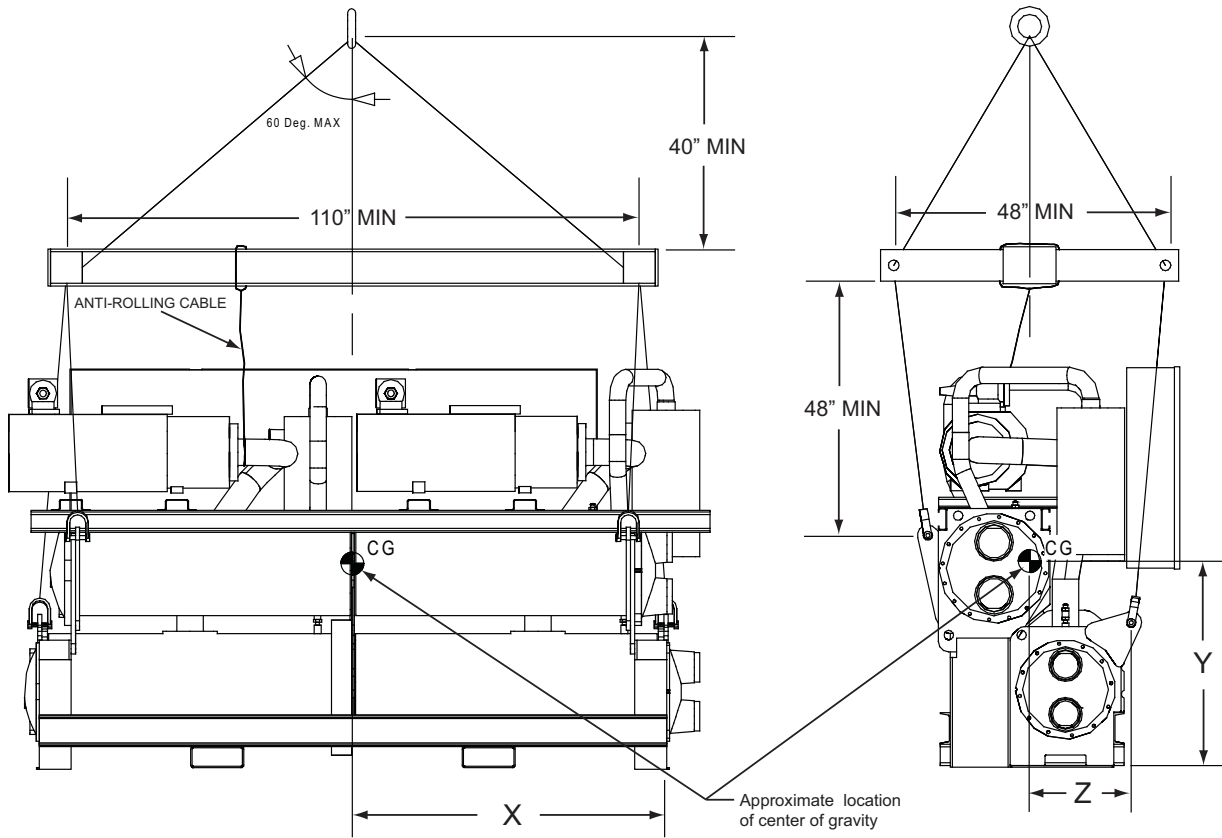

**Unit Isolation and Leveling**

**Mounting**

Construct an isolated concrete pad for the unit or provide concrete footings at each of the four unit mounting points. Mount the unit directly to the concrete pads or footings.

Level the unit using the base rail as a reference. The unit must be level within 1/4" over the entire length and width. Use shims as necessary to level the unit.

**Isolation Pads**

Note: The elastomeric pads shipped (as standard) are adequate for most installations. For additional details on isolation practices, refer to Trane Engineering Bulletin -Series R® Chiller Sound Ratings and Installation Guide, or consult an acoustical engineer for sound-sensitive installations.

During final positioning of the unit, place the isolation pads under the evaporator and condenser tube sheet supports as shown in Figure 13, p. 33. Level the unit as described in the next main paragraph.

**Neoprene Isolator Installation (optional)**

Install the optional neoprene isolators at each mounting location. Isolators are identified by part number and color. Refer to submittal drawing for correct isolators.

1. Secure the isolators to the mounting surface, using the mounting slots in the isolator base plate, as shown in Figure . Do not fully tighten the isolator mounting bolts at this time.
2. Align the mounting holes in the base of the unit, with the threaded positioning pins on the top of the isolators.
3. Lower the unit on to the isolators and secure the isolator to the unit with a nut.
4. Level the unit carefully. Refer to "Leveling". Fully tighten the isolator mounting bolts.



## Installation - Mechanical

Figure 13. Isolator pad placement

Note: Level unit to 1/4" (6.35 mm) across width and length

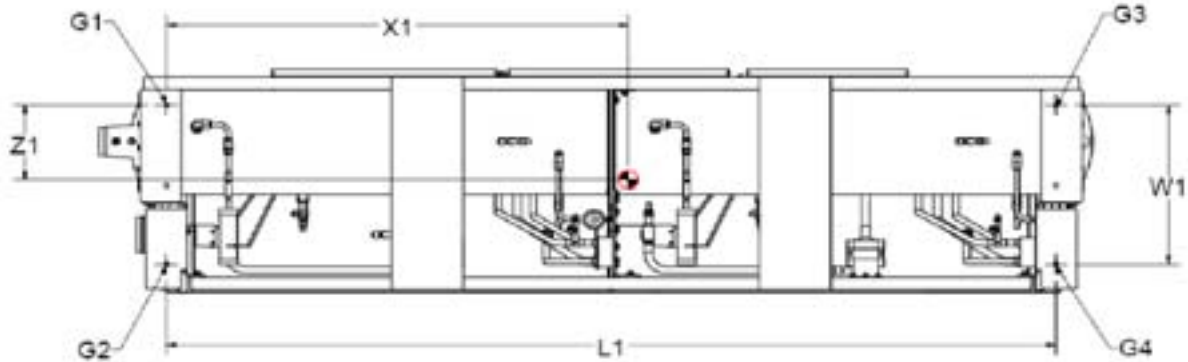

Figure 14. RTWD/RTUD neoprene isolator

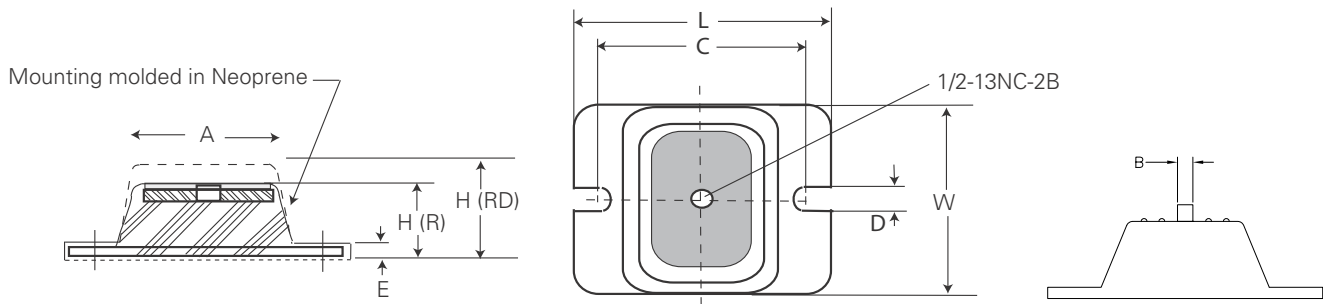

Table 21. Isolator part numbers and dimensions<sup>(a)</sup>

Model	Size	Hz	Effic.	Isolator Type Color [Ext] <sup>(b)</sup> Max Load- lbs (kg)	Maximum Deflection (in)	Dimension - in (mm)								
						A	B	C	D	E	H	L	W	
RTWD	80, 90, 100, 110, 120, 130, 140	60	STD											
RTWD	80, 90, 100, 110, 120, 130	60	HIGH											
RTWD	70, 80, 90, 100, 110, 120, 130, 140, 150	50	STD	RDP-4 Red [62] 2250 (1021)	0.50	3.0 (76.2)	0.50 (12.7)	5.00 (127.0)	0.56 (14.2)	0.38 (9.7)	2.75 (69.8)	6.25 (158.8)	4.63 (117.6)	
RTWD	60,70,80, 90, 100, 110, 120	50	HIGH											
RTUD	80, 90, 100, 110, 120, 130	60	HIGH											
RTWD	150, 160, 180, 200, 220, 250	60	HIGH											
RTWD	150, 160, 180, 200	60	PREM											
RTWD	130, 140, 160, 180, 200, 220, 250	50	HIGH	RDP-4 Green [63] 3000 (1361)	0.50	3.0 (76.2)	0.50 (12.7)	5.00 (127.0)	0.56 (14.2)	0.38 (9.7)	2.75 (69.8)	6.25 (158.8)	4.63 (117.6)	
RTWD	160, 180, 200	50	PREM											
RTUD	150, 160, 180, 200, 220, 250	60	HIGH											

(a) See submittal drawing to verify correct isolators.

(b) Part number is X10140305-xx

**Figure 15. Mounting point locations and weights**  
 RTWD - Std efficiency (all)  
 RTWD - High efficiency, 80-120T (60 Hz), 60-120T (50 Hz)  
 RTUD - 80-130T

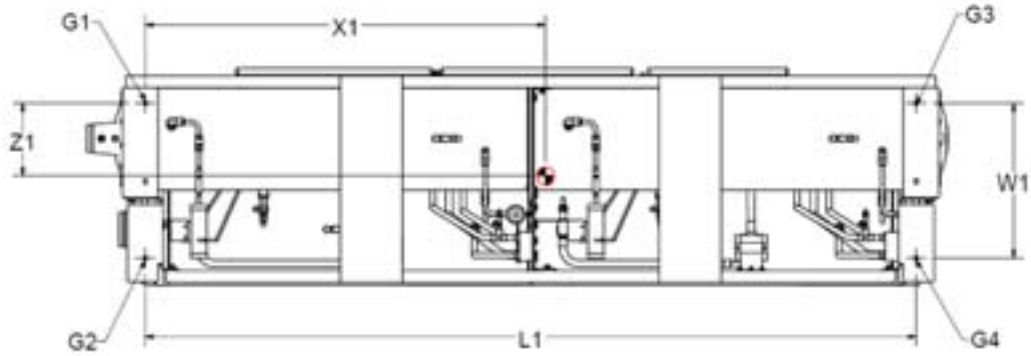

**Figure 16. Mounting point locations and weights**  
 RTWD - High efficiency, 150-250T (60Hz), 130-250T (50Hz)  
 RTWD - Premium efficiency (all)  
 RTUD - 150-250T

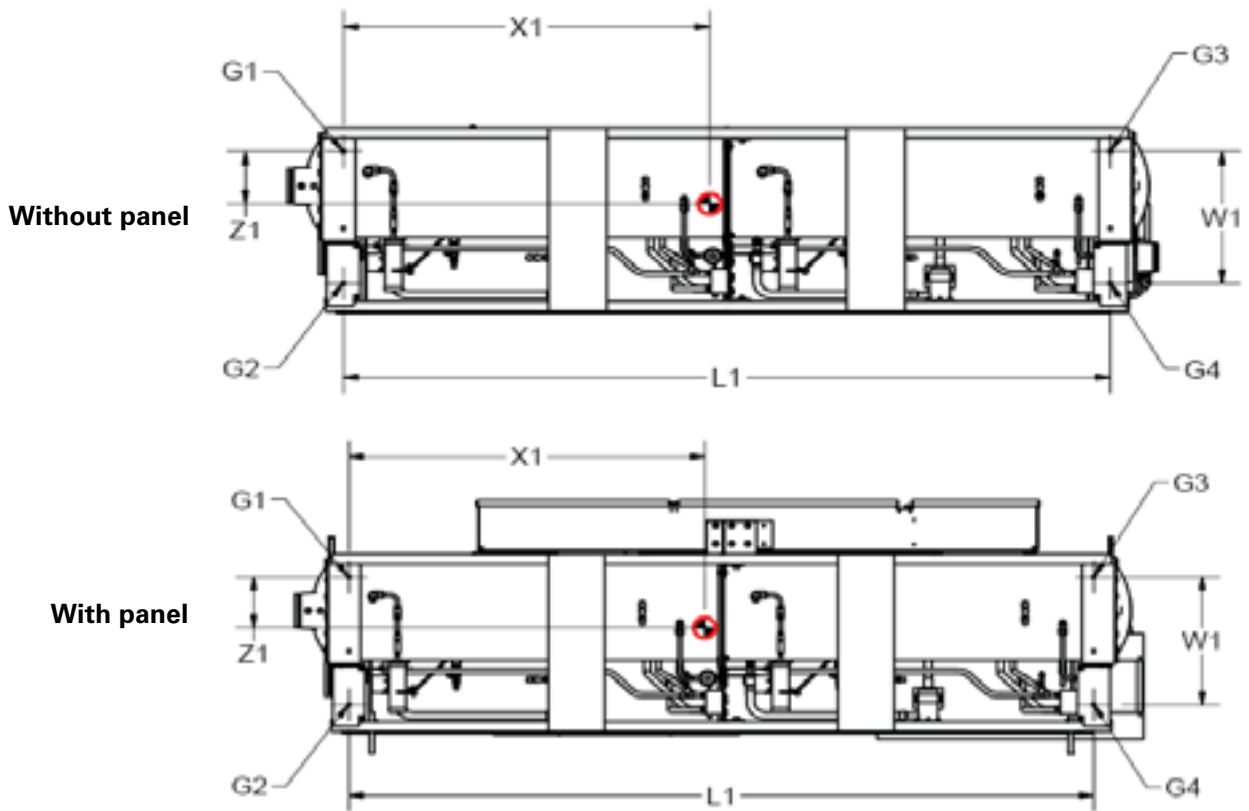

## Installation - Mechanical

Important: Isolators need to be placed under G1, G2, G3 and G4.

**Table 22. RTWD Corner weights, 60 Hz - Figure 15 - lb (kg)**

Unit	Corner Weights - lb (kg)				Operating Weight-lb (kg)
	G1	G2	G3	G4	
Standard Efficiency					
80	1566 (710)	1566 (710)	1385 (628)	1385 (628)	5902 (2676)
90	1571 (713)	1577 (715)	1390 (630)	1396 (633)	5934 (2691)
100	1599 (725)	1617 (733)	1454 (660)	1471 (667)	6141 (2785)
110	1662 (754)	1690 (767)	1477 (670)	1503 (681)	6332 (2872)
120	1689 (766)	1795 (814)	1477 (670)	1569 (712)	6530 (2962)
130	1688 (765)	1797 (815)	1478 (670)	1573 (713)	6536 (2964)
140	1654 (750)	1905 (864)	1586 (719)	1827 (829)	6972 (3162)
High Efficiency					
80	1465 (664)	1595 (724)	1279 (580)	1393 (632)	5732 (2600)
90	1479 (671)	1610 (730)	1294 (587)	1409 (639)	5792 (2627)
100	1602 (726)	1704 (773)	1429 (648)	1521 (690)	6256 (2837)
110	1673 (759)	1789 (811)	1457 (661)	1557 (706)	6476 (2937)
120	1680 (762)	1798 (816)	1465 (664)	1569 (711)	6512 (2953)
130	1685 (764)	1808 (820)	1472 (668)	1580 (716)	6545 (2968)

**Table 23. RTWD Corner weights, 50 Hz - Figure 15 - lb (kg)**

Unit	Corner Weights - lb (kg)				Operating Weight-lb (kg)
	G1	G2	G3	G4	
Standard Efficiency					
70	1555 (705)	1563 (709)	1375 (624)	1382 (627)	5875 (2664)
80	1560 (708)	1595 (723)	1422 (645)	1454 (659)	6031 (2735)
90	1592 (722)	1655 (751)	1442 (654)	1498 (680)	6187 (2806)
100	1621 (735)	1668 (756)	1468 (666)	1511 (685)	6268 (2843)
110	1662 (754)	1690 (766)	1477 (670)	1503 (681)	6332 (2872)
120	1634 (741)	1872 (852)	1578 (716)	1814 (823)	6905 (3131)
130	1692 (767)	2091 (948)	1590 (721)	1965 (891)	7338 (3328)
140	1696 (769)	2092 (949)	1591 (722)	1964 (891)	7343 (3330)
150	1707 (774)	2107 (956)	1603 (727)	1978 (897)	7395 (3354)
High Efficiency					
60	1455 (660)	1592 (722)	1270 (576)	1389 (630)	5706 (2588)
70	1461 (663)	1595 (723)	1275 (578)	1392 (631)	5723 (2596)
80	1468 (666)	1632 (740)	1324 (600)	1471 (667)	5894 (2673)
90	1600 (726)	1747 (792)	1421 (645)	1551 (704)	6320 (2866)
100	1631 (740)	1765 (800)	1448 (657)	1567 (711)	6412 (2908)
110	1678 (761)	1793 (813)	1463 (663)	1563 (709)	6497 (2946)
120	1635 (741)	1894 (859)	1569 (711)	1817 (824)	6914 (3136)



## Installation - Mechanical

**Table 24. RTWD Corner weights, 60 Hz - Figure 16 - lb (kg)**

Unit	Corner Weights - lb (kg)				Operating Weight-lb (kg)
	G1	G2	G3	G4	
High Efficiency, No Panel					
150	1425 (646)	2102 (953)	1482 (672)	2185 (991)	7194 (3262)
160	1524 (691)	2361 (1071)	1498 (680)	2322 (1053)	7706 (3495)
180	1539 (698)	2385 (1081)	1520 (689)	2356 (1068)	7798 (3537)
200	1556 (706)	2410 (1093)	1538 (698)	2383 (1081)	7887 (3577)
220	1712 (777)	2611 (1184)	1769 (802)	2697 (1223)	8789 (3986)
250	1793 (813)	2826 (1282)	1837 (833)	2895 (1313)	9352 (4241)
Premium Efficiency, No Panel					
150	1638 (743)	2299 (1043)	1704 (773)	2393 (1085)	8033 (3643)
160	1716 (778)	2525 (1145)	1715 (778)	2524 (1145)	8481 (3846)
180	1736 (787)	2564 (1163)	1737 (788)	2564 (1163)	8601 (3901)
200	1749 (793)	2572 (1166)	1751 (794)	2575 (1168)	8647 (3921)

**Table 25. RTWD Corner weights, 60 Hz- Figure 16 - lb (kg)**

Unit	Corner Weights - lb (kg)				Operating Weight-lb (kg)
	G1	G2	G3	G4	
High Efficiency, With Panel					
150	1181 (853)	2010 (911)	1937 (878)	2070 (939)	7897 (3581)
160	1987 (901)	2261 (1025)	1946 (883)	2215 (1004)	8409 (3814)
180	2002 (908)	2284 (1036)	1969 (893)	2246 (1019)	8502 (3856)
200	2020 (916)	2309 (1047)	1989 (902)	2273 (1031)	8590 (3896)
220	2171 (985)	2515 (1141)	2226 (1010)	2579 (1170)	9492 (4305)
250	2256 (1023)	2728 (1237)	2296 (1041)	2776 (1259)	10056 (4560)
Premium Efficiency, With Panel					
150	2089 (947)	2195 (996)	2171 (985)	2281 (1035)	8737 (3962)
160	2173 (985)	2416 (1096)	2176 (987)	2420 (1097)	9184 (4165)
180	2194 (995)	2454 (1113)	2198 (997)	2458 (1115)	9304 (4220)
200	2207 (1001)	2461 (1116)	2213 (1004)	2468 (1119)	9350 (4240)

**Table 26. RTWD Corner weights, 50 Hz- Figure 16 - lb (kg)**

Unit	Corner Weights - lb (kg)				Operating Weight-lb (kg)
	G1	G2	G3	G4	
High Efficiency, No Panel					
130	1429 (648)	2307 (1046)	1434 (650)	2316 (1050)	7486 (3395)
140	1443 (654)	2328 (1056)	1448 (657)	2336 (1059)	7555 (3426)
160	1465 (664)	2355 (1068)	1469 (666)	2362 (1071)	8069 (3470)
180	1480 (671)	2401 (1089)	1597 (724)	2592 (1175)	8069 (3660)
200	1735 (787)	2724 (1235)	1782 (808)	2798 (1269)	9039 (4099)
220	1748 (793)	2731 (1238)	1794 (814)	2803 (1271)	9075 (4116)
250	1779 (807)	2784 (1263)	1824 (827)	2854 (1294)	9240 (4191)
Premium Efficiency, No Panel					
160	1651 (749)	2504 (1136)	1675 (759)	2540 (1152)	8370 (3796)
180	1679 (762)	2590 (1174)	1813 (822)	2796 (1268)	8877 (4026)
200	1785 (809)	2823 (1280)	1833 (831)	2900 (1315)	9341 (4236)

## Installation - Mechanical

**Table 27. RTWD Corner weights, 50 Hz - Figure 16 - lb (kg)**

Unit	Corner Weights - lb (kg)				Operating Weight-lb (kg)
	G1	G2	G3	G4	
High Efficiency, With Panel					
130	1889 (857)	2211 (1003)	1884 (855)	2205 (1000)	8190 (3714)
140	1904 (863)	2231 (1012)	1899 (861)	2225 (1009)	8258 (3745)
160	1927 (874)	2257 (1023)	1921 (871)	2250 (1020)	8355 (3789)
180	1931 (876)	2314 (1049)	2060 (934)	2468 (1119)	8773 (3979)
200	2195 (995)	2628 (1192)	2239 (1015)	2681 (1216)	9743 (4418)
220	2208 (1001)	2635 (1195)	2250 (1021)	2686 (1218)	9779 (4435)
250	2241 (1016)	2686 (1218)	2281 (1035)	2735 (1240)	9943 (4510)
Premium Efficiency, With Panel					
160	2106 (955)	2396 (1087)	2138 (970)	2433 (1103)	9073 (4115)
180	2127 (964)	5491 (1130)	2286 (1037)	2677 (1214)	9580 (4345)
200	2245 (1018)	2723 (1235)	2291 (1039)	2778 (1260)	10045 (4555)

**Table 28. RTUD Corner weights, 60 Hz - Figure 15 - lb (kg)**

Unit	Corner Weights - lb (kg)				Operating Weight-lb (kg)
	G1	G2	G3	G4	
High Efficiency					
80	1331 (605)	1254 (570)	1173 (533)	1104 (502)	4874 (2211)
90	1338 (608)	1258 (572)	1179 (536)	1109 (504)	4892 (2219)
100	1357 (617)	1280 (582)	1247 (567)	1177 (535)	5073 (2301)
110	1454 (661)	1357 (617)	1296 (589)	1210 (550)	5326 (2416)
120	1468 (666)	1367 (620)	1310 (594)	1219 (553)	5366 (2434)
130	1468 (666)	1367 (620)	1310 (594)	1219 (553)	5366 (2434)

**Table 29. RTUD Corner weights, 60 Hz - Figure 16 - lb (kg)**

Unit	Corner Weights - lb (kg)				Operating Weight-lb (kg)
	G1	G2	G3	G4	
High Efficiency, No Panel					
150	964 (438)	1399 (636)	1168 (531)	1698 (772)	5240 (2377)
160	1087 (494)	1775 (807)	1221 (555)	1995 (907)	6089 (2762)
180	1111 (505)	1780 (809)	1252 (569)	2992 (910)	6158 (2793)
200	1162 (528)	1813 (824)	1276 (580)	1991 (905)	6257 (2838)
220	1148 (522)	1837 (835)	1377 (626)	2200 (1000)	6576 (2983)
250	1192 (542)	1956 (889)	1406 (639)	2308 (1049)	6878 (3120)
High Efficiency, With Panel					
150	1242 (564)	1549 (704)	1386 (630)	1729 (786)	5917 (2684)
160	1522 (692)	1709 (777)	1676 (762)	1881 (855)	6803 (3086)
180	1549 (704)	1714 (779)	1707 (776)	1890 (859)	6876 (3119)
200	1606 (730)	1745 (793)	1731 (787)	1881 (855)	6980 (3166)
220	1582 (719)	1782 (810)	1844 (838)	2077 (944)	7300 (3311)
250	1628 (740)	1901 (864)	1872 (851)	2185 (993)	7602 (3448)

### Center of Gravity

**Figure 17. Center of gravity**  
 RTWD - Std efficiency (all)  
 RTWD - High efficiency, 80-120T (60 Hz), 60-120T (50 Hz)  
 RTUD - 80-130T

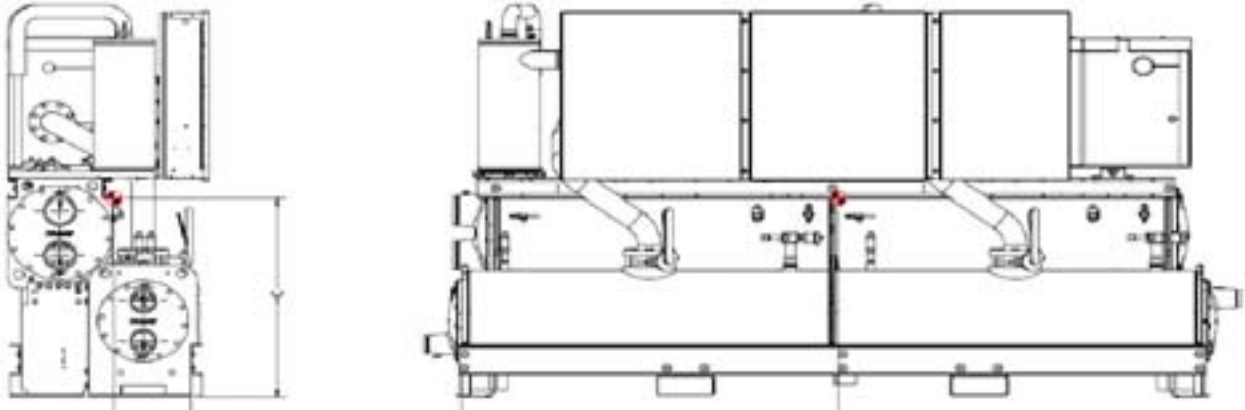

**Figure 18. Center of gravity**  
 RTWD - High efficiency, 150-250T (60Hz), 130-250T (50Hz)  
 RTWD - Premium efficiency (all)  
 RTUD - 150-250T

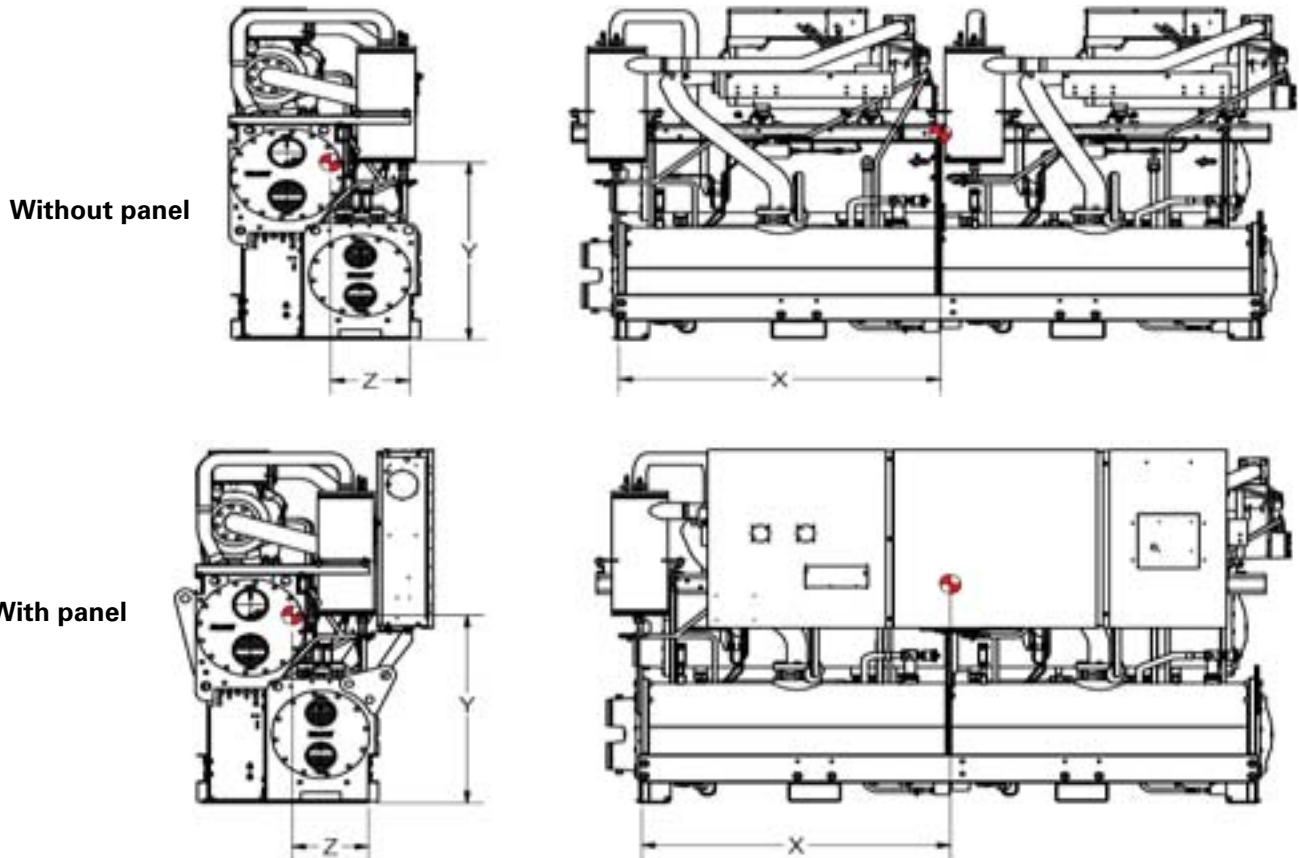

## Installation - Mechanical

**Table 30. RTWD Center of gravity, 60Hz - Figure 17 - in (mm)**

Unit	Standard Efficiency			High Efficiency		
	X	Y	Z	X	Y	Z
80	61 (1543)	34 (868)	15 (381)	55 (1393)	35 (879)	16 (394)
90	61 (1544)	34 (868)	15 (381)	55 (1395)	35 (877)	16 (394)
100	62 (1566)	35 (879)	15 (382)	55 (1409)	34 (869)	15 (390)
110	61 (1547)	35 (891)	15 (383)	55 (1391)	35 (880)	15 (391)
120	60 (1534)	34 (876)	15 (390)	55 (1393)	35 (879)	15 (391)
130	60 (1535)	35 (876)	15 (391)	55 (1394)	35 (879)	15 (392)
140	63 (1607)	36 (903)	16 (403)	-	-	-

**Table 31. RTWD Center of gravity, 50Hz - Figure 17 - in (mm)**

Unit	Standard Efficiency			High Efficiency		
	X	Y	Z	X	Y	Z
60	-	-	-	55 (1393)	35 (879)	16 (395)
70	61 (1543)	34 (868)	15 (381)	55 (1393)	35 (878)	16 (395)
80	62 (1567)	34 (875)	15 (384)	56 (1416)	35 (885)	16 (397)
90	61 (1562)	35 (882)	15 (387)	55 (1405)	34 (871)	16 (395)
100	61 (1562)	35 (886)	15 (385)	55 (1405)	34 (876)	15 (393)
110	61 (1547)	35 (891)	15 (383)	55 (1393)	35 (879)	15 (391)
120	63 (1612)	36 (905)	16 (403)	57 (1460)	36 (907)	16 (404)
130	63 (1591)	37 (929)	16 (414)	55 (1393)	35 (879)	16 (395)
140	63 (1590)	37 (929)	16 (414)	-	-	-
150	63 (1590)	37 (927)	16 (414)	-	-	-

**Table 32. RTWD Center of gravity, 60Hz - Figure 18 - in (mm)**

Unit	High Efficiency			Premium Efficiency		
	X	Y	Z	X	Y	Z
No Panel						
150	60 (1518)	38 (959)	17 (441)	70 (1773)	37 (949)	17 (434)
160	58 (1478)	39 (989)	18 (449)	68 (1740)	39 (980)	17 (441)
180	58 (1481)	39 (987)	18 (449)	68 (1740)	38 (978)	17 (442)
200	58 (1482)	39 (985)	18 (449)	68 (1741)	38 (977)	17 (441)
220	60 (1513)	40 (1006)	18 (446)	-	-	-
250	59 (1507)	40 (1019)	18 (451)	-	-	-
With Panel						
150	59 (1511)	39 (995)	15 (391)	70 (1772)	39 (986)	15 (388)
160	58 (1475)	40 (1020)	16 (401)	68 (1741)	40 (1012)	16 (397)
180	58 (1478)	40 (1018)	16 (401)	69 (1742)	40 (1010)	16 (398)
200	58 (1479)	40 (1016)	16 (402)	69 (1742)	40 (1008)	16 (398)
220	59 (1508)	41 (1035)	16 (404)	-	-	-
250	59 (1502)	41 (1046)	16 (411)	-	-	-



## Installation - Mechanical

**Table 33. RTWD Center of gravity, 50Hz - Figure 18 - in (mm)**

Unit	High Efficiency			Premium Efficiency		
	X	Y	Z	X	Y	Z
No Panel						
120	59 (1493)	39 (988)	18 (455)	-	-	-
140	59 (1492)	39 (986)	18 (455)	-	-	-
160	59 (1492)	39 (983)	18 (454)	69 (1752)	38 (974)	17 (446)
180	61 (1544)	39 (1002)	18 (456)	71 (1804)	39 (993)	18 (448)
200	59 (1509)	40 (1025)	18 (451)	59 (1509)	40 (1021)	18 (452)
220	59 (1509)	40 (1023)	18 (450)	-	-	-
250	59 (1508)	40 (1020)	18 (450)	-	-	-
With Panel						
120	59 (1488)	40 (1020)	16 (405)	-	-	-
140	59 (1488)	40 (1018)	16 (406)	-	-	-
160	59 (1488)	40 (1015)	16 (406)	69 (1752)	40 (1007)	16 (401)
180	60 (1536)	41 (1031)	16 (409)	71 (1800)	40 (1023)	16 (406)
200	59 (1504)	41 (1052)	16 (409)	59 (1504)	41 (1047)	16 (411)
220	59 (1504)	41 (1050)	16 (409)	-	-	-
250	59 (1503)	41 (1047)	16 (409)	-	-	-

**Table 34. RTUD Center of gravity, 60Hz- Figure 17-in (mm)**

Unit	High Efficiency		
	X	Y	Z
80	55 (1400)	35 (895)	15 (371)
90	55 (1400)	35 (894)	15 (371)
100	56 (1430)	36 (906)	15 (372)
110	55 (1408)	36 (909)	15 (370)
120	55 (1408)	36 (908)	15 (369)
130	55 (1408)	36 (908)	15 (369)

**Table 35. RTUD Center of gravity, 60Hz- Figure 18-in (mm)**

Unit	High Efficiency		
	X	Y	Z
No Panel			
150	64 (1627)	38 (959)	17 (439)
160	62 (1573)	41 (1034)	18 (457)
180	62 (1574)	41 (1037)	18 (454)
200	61 (1557)	41 (1037)	18 (450)
220	64 (1618)	42 (1055)	18 (454)
250	63 (1607)	42 (1070)	18 (457)
With Panel			
150	62 (1568)	38 (973)	16 (416)
160	61 (1558)	42 (1067)	16 (399)
180	61 (1559)	42 (1069)	16 (397)
200	61 (1543)	42 (1069)	16 (394)
220	63 (1599)	43 (1084)	16 (399)
250	63 (1589)	43 (1097)	16 (405)

## Evaporator Piping

Thoroughly flush all water piping to the unit before making the final piping connections to the unit.

Components and layout will vary slightly, depending on the location of connections and the water source.

### NOTICE:

#### Evaporator Damage!

The chilled water connections to the evaporator are to be grooved-pipe type connections. Do not attempt to weld these connections, as the heat generated from welding can cause microscopic and macroscopic fractures on the cast iron waterboxes that can lead to premature failure of the waterbox. To prevent damage to chilled water components, do not allow evaporator pressure (maximum working pressure) to exceed 150 psig (10.5 bar).

### NOTICE:

#### Equipment Damage!

If using an acidic commercial flushing solution when flushing the water piping, construct a temporary bypass around the unit to prevent damage to internal components of the evaporator.

### NOTICE:

#### Equipment Damage!

To prevent evaporator or condenser damage, pipe strainers must be installed in the water supplies to protect components from water born debris. Trane is not responsible for equipment-only-damage caused by water born debris.



## Installation - Mechanical

### NOTICE:

#### Proper Water Treatment!

The use of untreated or improperly treated water could result in scaling, erosion, corrosion, algae or slime. It is recommended that the services of a qualified water treatment specialist be engaged to determine what water treatment, if any, is required. Trane assumes no responsibility for equipment failures which result from untreated or improperly treated water, or saline or brackish water.

#### Drainage

Locate the unit near a large capacity drain for water vessel drain-down during shutdown or repair. Condensers and evaporators are provided with drain connections. Refer to "Water Piping." All local and national codes apply.

A vent is provided on the top of the evaporator at the return end. Be sure to provide additional vents at high points in the piping to bleed air from the chilled water system. Install necessary pressure gauges to monitor the entering and leaving chilled water pressures.

Provide shutoff valves in lines to the gauges to isolate them from the system when they are not in use. Use rubber vibration eliminators to prevent vibration transmission through the water lines.

If desired, install thermometers in lines to monitor entering and leaving water temperatures. Install a balancing valve in leaving water line to control water flow balance. Install shutoff valves on both entering and leaving water lines to isolate evaporator for service.

A pipe strainer must be installed in entering water line to prevent water-borne debris from entering the evaporator.

#### Reversing Water Boxes

### NOTICE:

#### Equipment Damage!

Do NOT rotate or swap evaporator or condenser water boxes end-for-end. Altering water boxes can affect equipment operation and can cause equipment damage.

Water boxes on evaporator and condenser can NOT be rotated or swapped end for end. Altering water boxes will lead to poor efficiency, poor oil management and possible freeze-up of evaporator.

Figure 19. RTWD water boxes



#### Evaporator Piping Components

"Piping components" include all devices and controls used to provide proper water system operation and unit operating safety. These components and their general locations are given below.

#### Entering Chilled Water Piping - Field Installed

- Air vents (to bleed air from system)
- Water pressure gauges with shutoff valves
- Vibration eliminators
- Shutoff (isolation) valves
- Thermometers (if desired)
- Cleanout tees
- Relief valve
- Pipe strainer

### NOTICE:

#### Water Born Debris!

To prevent evaporator or condenser damage, pipe strainers must be installed in the water supplies to protect components from water born debris. Trane is not responsible for equipment-only-damage caused by water born debris.

### NOTICE:

#### Evaporator Damage!

The chilled water connections to the evaporator are to be grooved-pipe type connections. Do not attempt to weld these connections, as the heat generated from welding can cause microscopic and macroscopic fractures on the cast iron waterboxes that can lead to premature failure of the waterbox. To prevent damage to chilled water components, do not allow evaporator pressure (maximum working pressure) to exceed 150 psig (10.5 bar).

#### Leaving Chilled Water Piping - Field Installed

- Air vents (to bleed air from system)
- Water pressure gauges with shutoff valves
- Vibration eliminators
- Shutoff (isolation) valves
- Thermometers
- Cleanout tees
- Balancing valve
- Flow Switch (not required if factory installed flow switch option is selected)

#### Evaporator Flow Switch (Optional)

If factory installed flow switch option is selected, switch is programmed based on the operating conditions submitted with the order. The leaving evaporator temperature, fluid type and fluid concentration affect the selected flow switch. If the operating conditions on the job site change, the flow switch may need to be replaced.

## Installation - Mechanical

The sensor head includes 3 LEDs, two yellow and one green. Wait 15 seconds after power is applied to the sensor before evaluating LEDs for flow status. When wired correctly and flow is established, only the green LED should be lit. Following are the LED indicators:

- Green ON, both yellow OFF — Flow
- Green and outside yellow ON — No Flow
- Center yellow ON continuously — Miswire

### **NOTICE:**

#### **Proper Water Treatment!**

The use of untreated or improperly treated water in this equipment could result in scaling, erosion, corrosion, algae or slime. It is recommended that the services of a qualified water treatment specialist be engaged to determine what water treatment, if any, is required. Trane assumes no responsibility for equipment failures which result from untreated or improperly treated water, or saline or brackish water.

**Important:** If using an acidic commercial flushing solution, construct a temporary bypass around the unit to prevent damage to internal components of the evaporator.

Dirt, scale, products of corrosion and other foreign material will adversely affect heat transfer between the water and system components. Foreign matter in the chilled water system can also increase pressure drop and, consequently, reduce water flow. Proper water treatment must be determined locally, depending on the type of system and local water characteristics.

Neither salt nor brackish water is recommended for use in Trane air-cooled Series R<sup>®</sup> chillers. Use of either will lead to a shortened life to an indeterminable degree. The Trane Company encourages the employment of a reputable water treatment specialist, familiar with local water conditions, to assist in this determination and in the establishment of a proper water treatment program.

Using untreated or improperly treated water in these units may result in inefficient operation and possible tube damage. Consult a qualified water treatment specialist to determine whether treatment is needed.

#### **Indexing Flow Switch**

To properly index the flow switch, the following requirements must be met:

- Dot must be at a position no greater than 90° off Index.
- Torque must be between 22 ft-lb min and 74 ft-lb max.
- A minimum distance of 5x pipe diameter must be maintained between flow switch and any bends, valves, changes in cross sections, etc.

**Figure 20. Proper flow switch indexing**

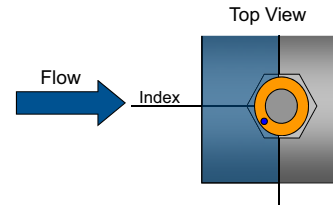

The flow switch must have the dot in the shaded area to the left of this line for proper indexing ( $\pm 90^\circ$  off Index)

### **Flow Proving Devices**

#### **NOTICE:**

#### **Evaporator Damage!**

For all RTUD units, chilled water pumps **MUST** be controlled by the Trane CH530 to avoid catastrophic damage to the evaporator due to freezing.

**Important:** If factory installed flow switch option is not selected, installer must provide flow switches or differential pressure switches with pump interlocks to prove water flow.

To provide chiller protection, install and wire flow switches in series with the water pump interlocks, for both chilled water and condenser water circuits (see “[Installation - Electrical](#)” chapter). Specific connections and schematic wiring diagrams are shipped with the unit.

Flow switches must prevent or stop compressor operation if either system water flow drops off below the required minimum shown on the pressure drop curves. Follow the manufacturer’s recommendations for selection and installation procedures. General guidelines for flow switch installation are outlined below.

- Mount the switch upright, with a minimum of 5 pipe diameters straight, horizontal run on each side.
- Do not install close to elbows, orifices or valves.

**Note:** The arrow on switch must point in direction of water flow.

- To prevent switch fluttering, remove all air from water system.

**Note:** CH530 provides a 6-sec time delay on flow switch input before shutting down unit on loss-of-flow diagnostic. Contact a qualified service organization if nuisance machine shutdowns persist.

- Adjust switch to open when water flow falls below minimum. See General Data tables for minimum flow recommendations. Flow switch is closed on proof of water flow.

#### **NOTICE:**

#### **Evaporator Damage!**

To prevent evaporator damage, do not use water flow switch to cycle the system.

## Installation - Mechanical

### Pressure Drop Curves

For overlapping pressure drop curves, see General Data tables in section "General Information," p. 9 for limit values.

Figure 21. Evaporator pressure drop curves - 2 pass, 60 Hz - RTWD, RTUD

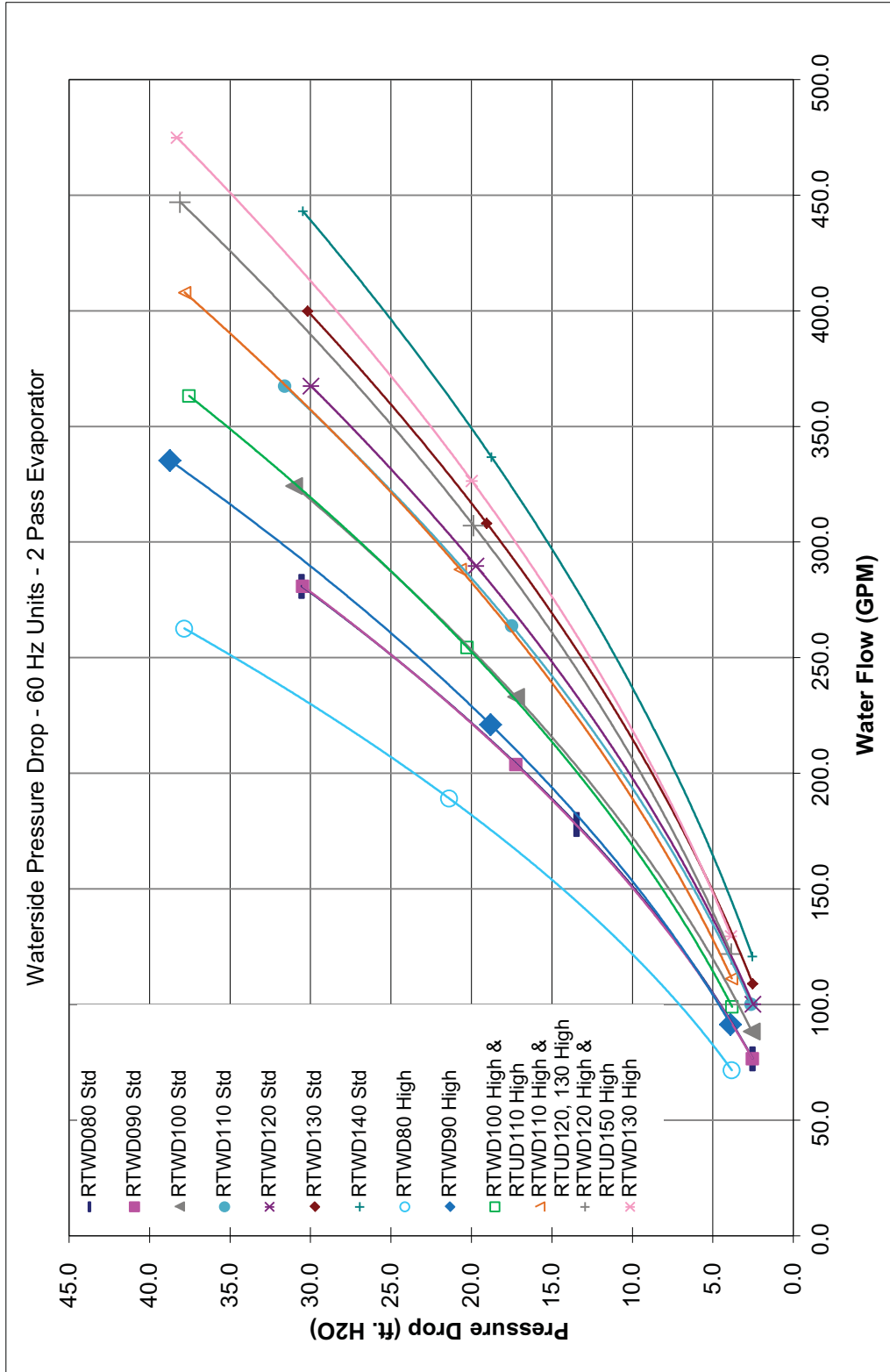
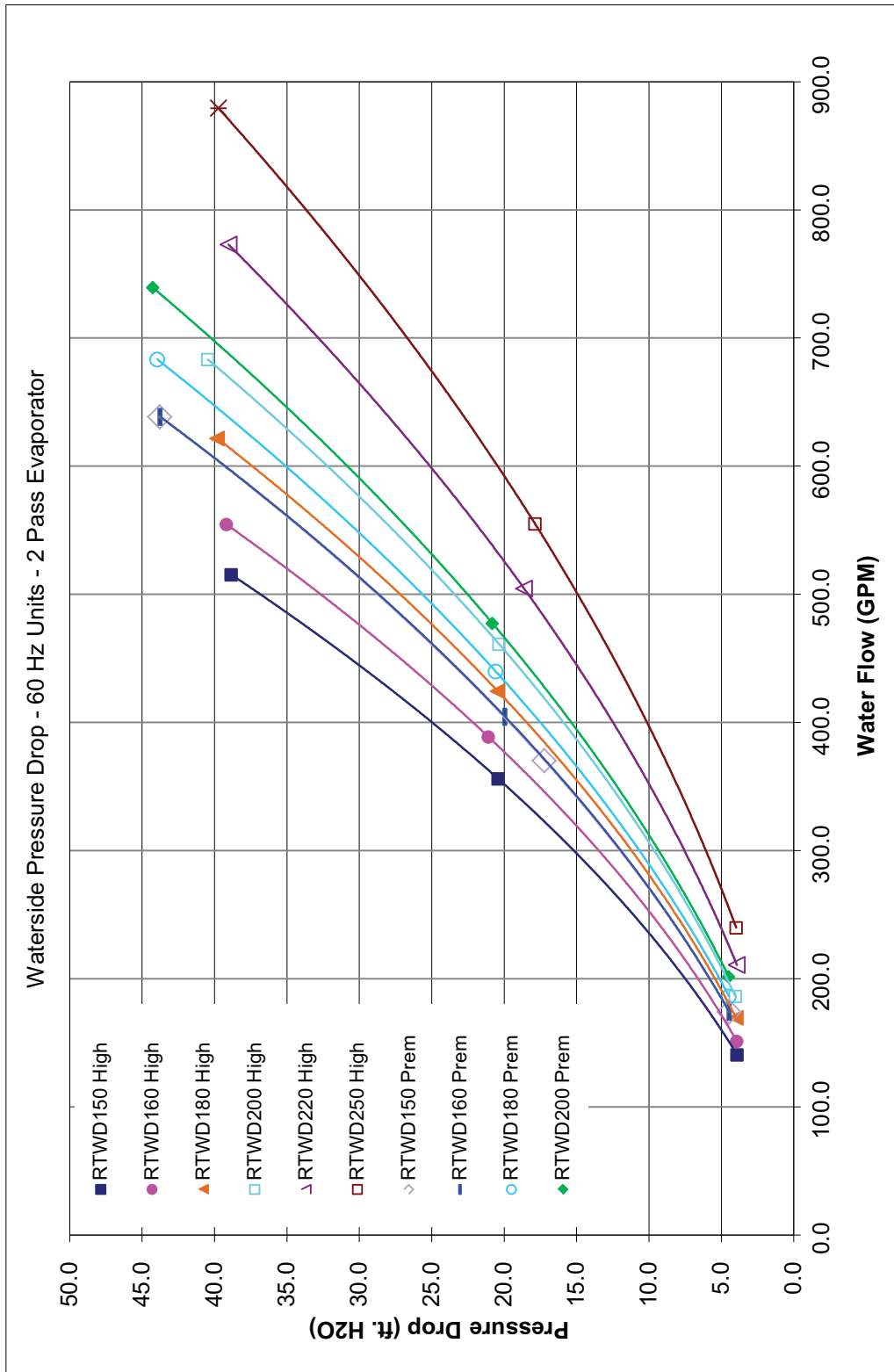

Figure 22. Evaporator pressure drop curves - 2 pass, 60 Hz - RTWD, RTUD



# Installation - Mechanical

Figure 23. Evaporator pressure drop curves - 2 pass - RTWD 50 Hz, RTUD 60 Hz

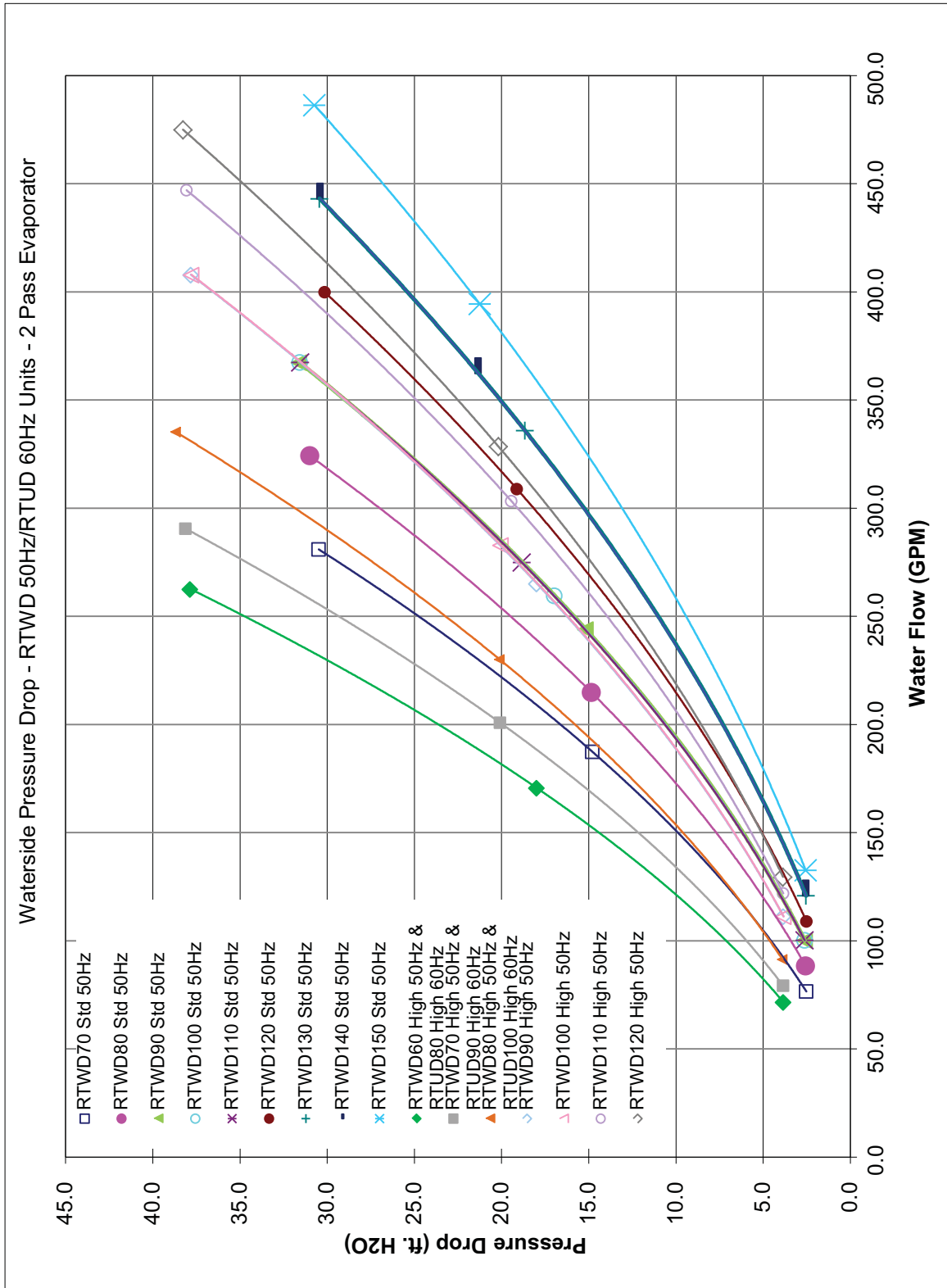
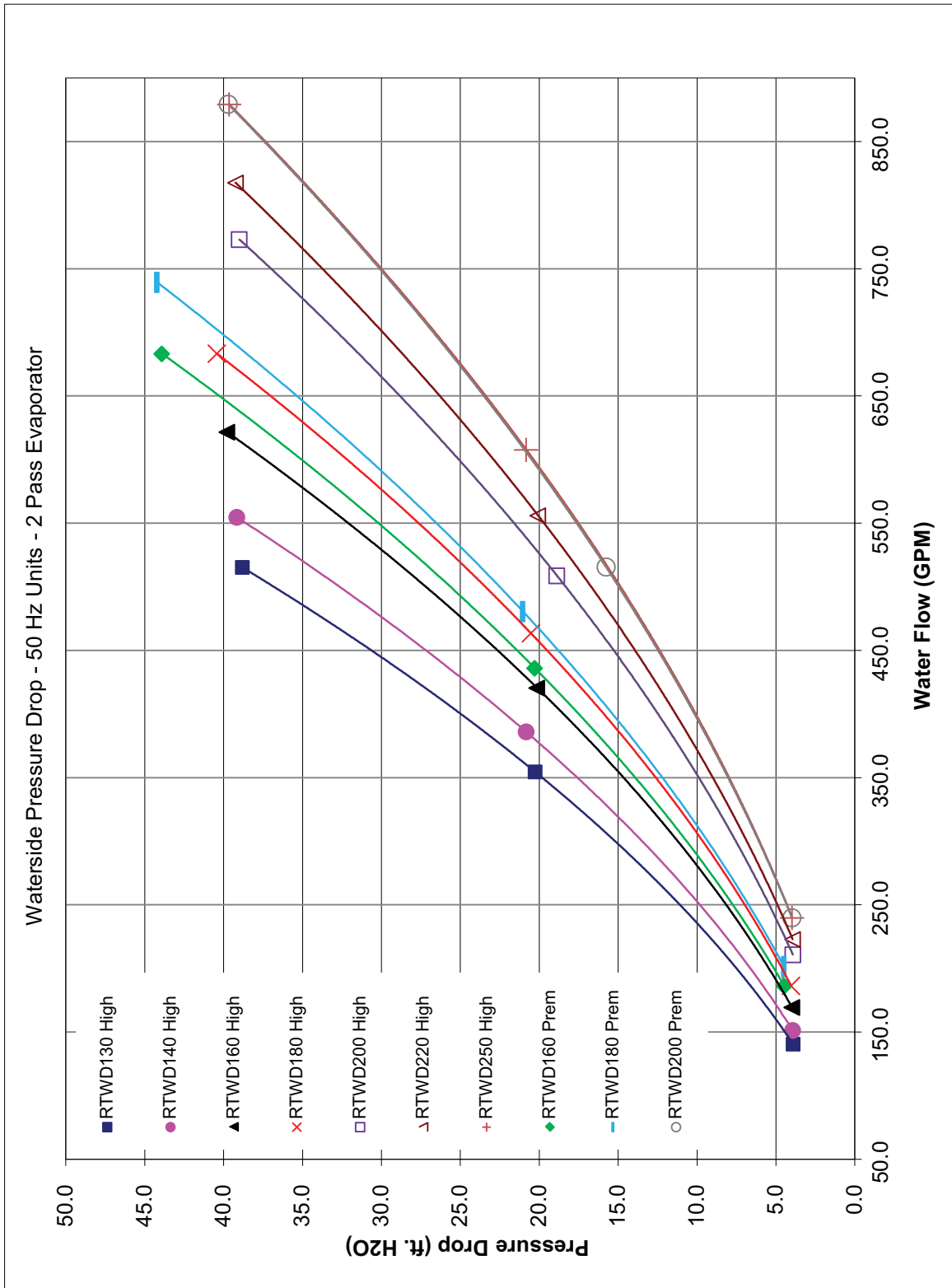

Figure 24. Evaporator pressure drop curves - 2 pass, 50 hz - RTWD



# Installation - Mechanical

Figure 25. Evaporator pressure drop curves - 3 pass, 60 hz - RTWD, RTUD

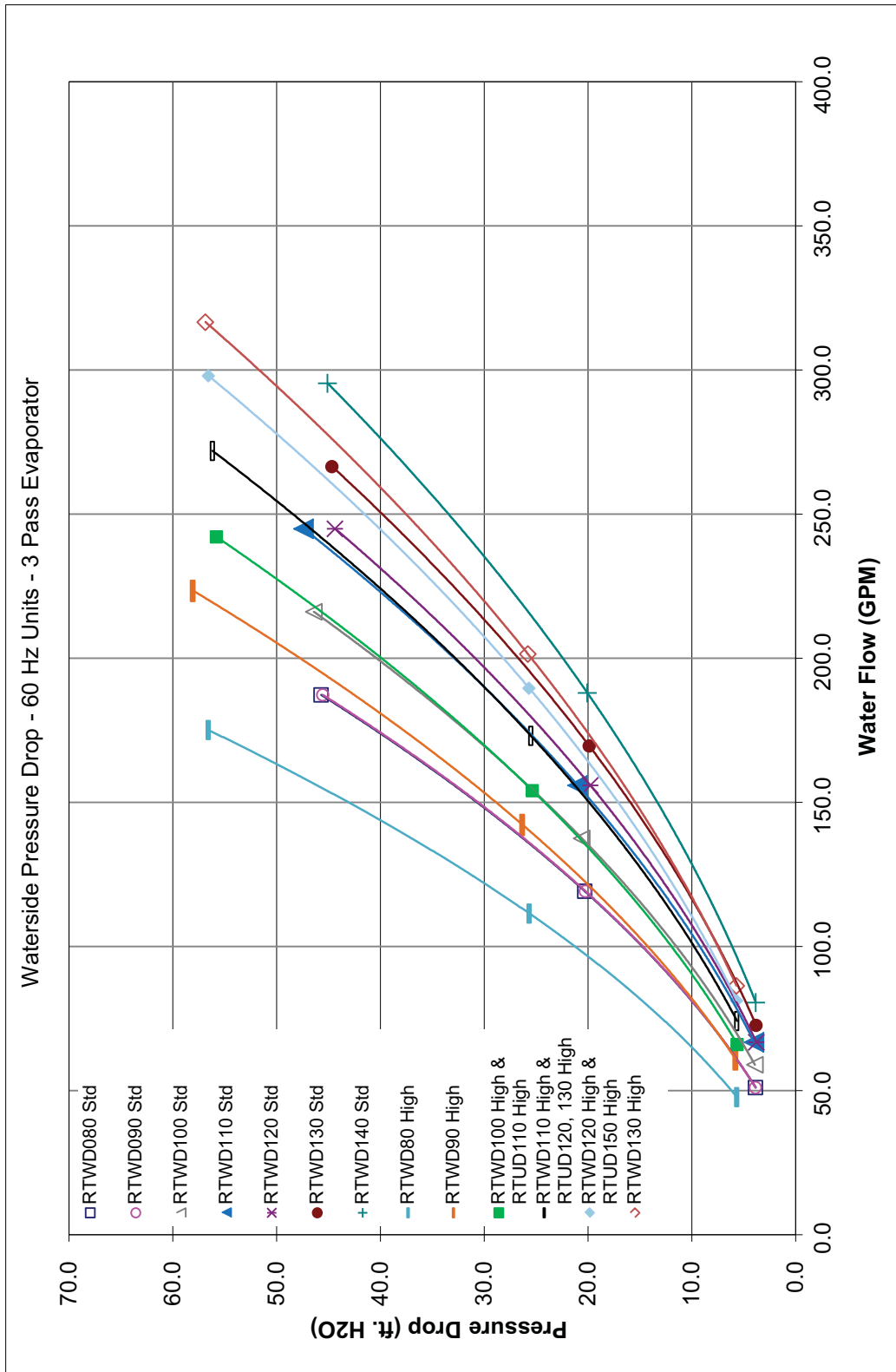
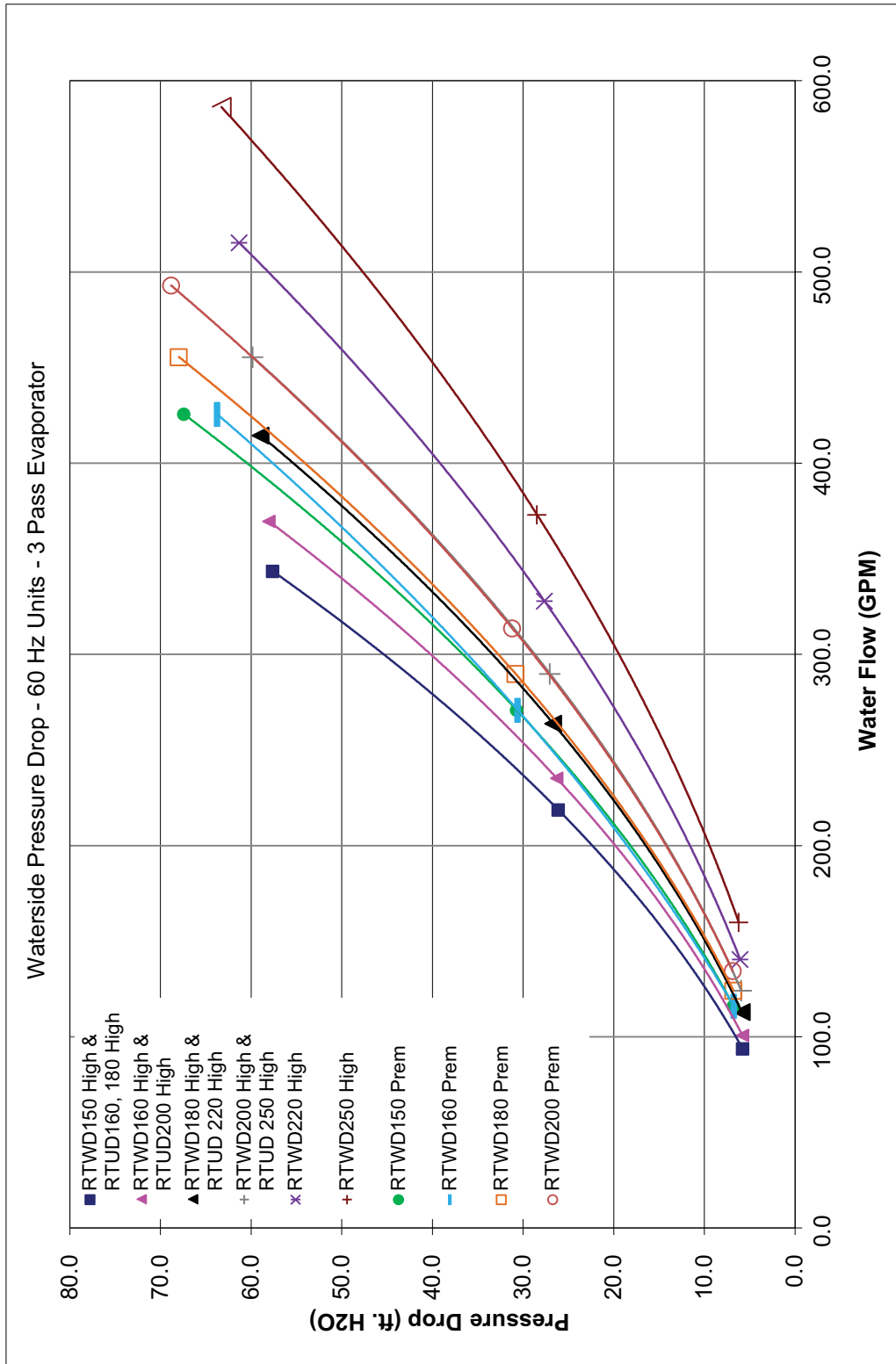

Figure 26. Evaporator pressure drop curves - 3 pass, 60 hz - RTWD, RTUD





# Installation - Mechanical

Figure 27. Evaporator pressure drop curves - 3 pass - RTWD 50 Hz, RTUD 60 Hz

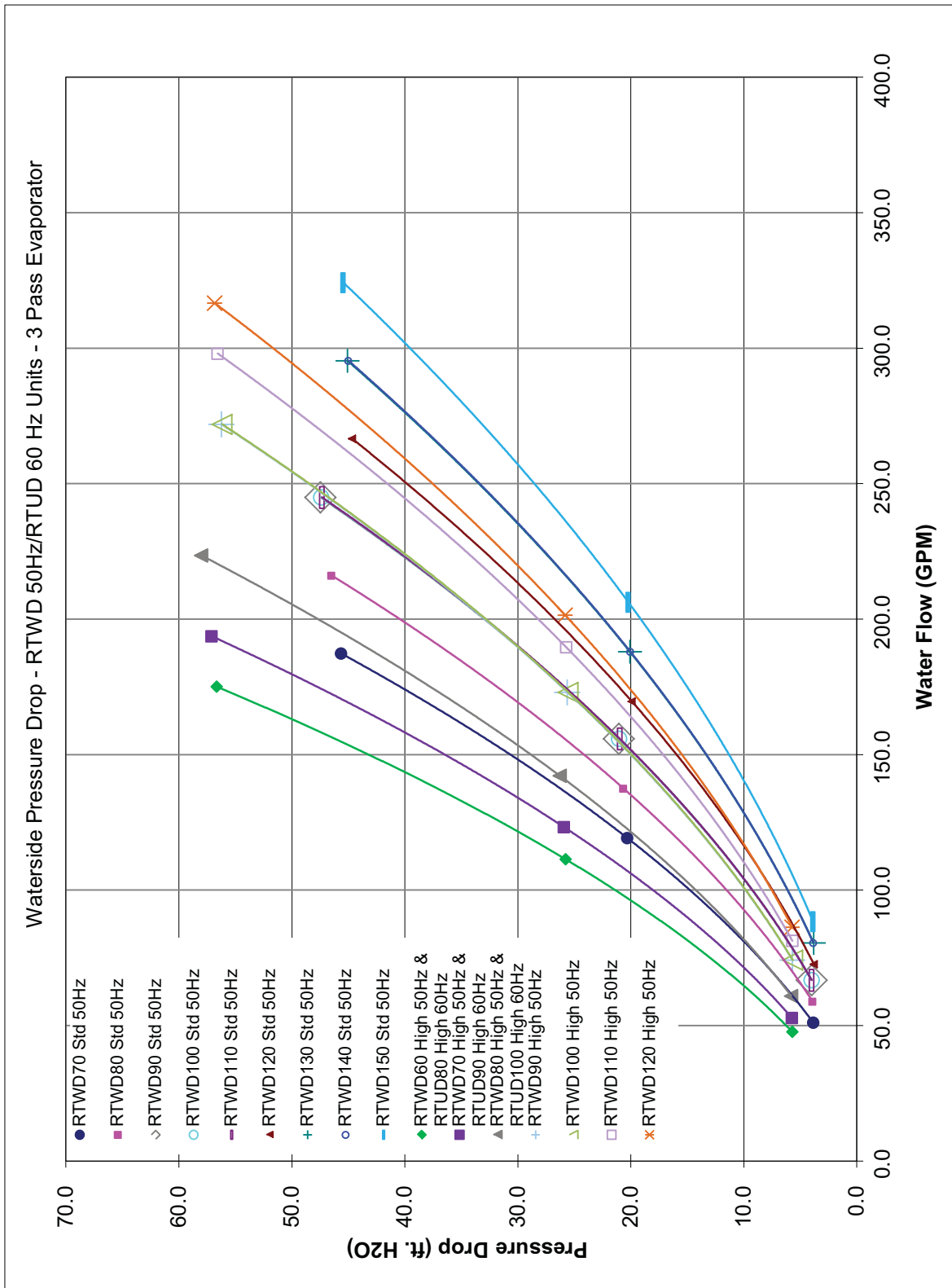
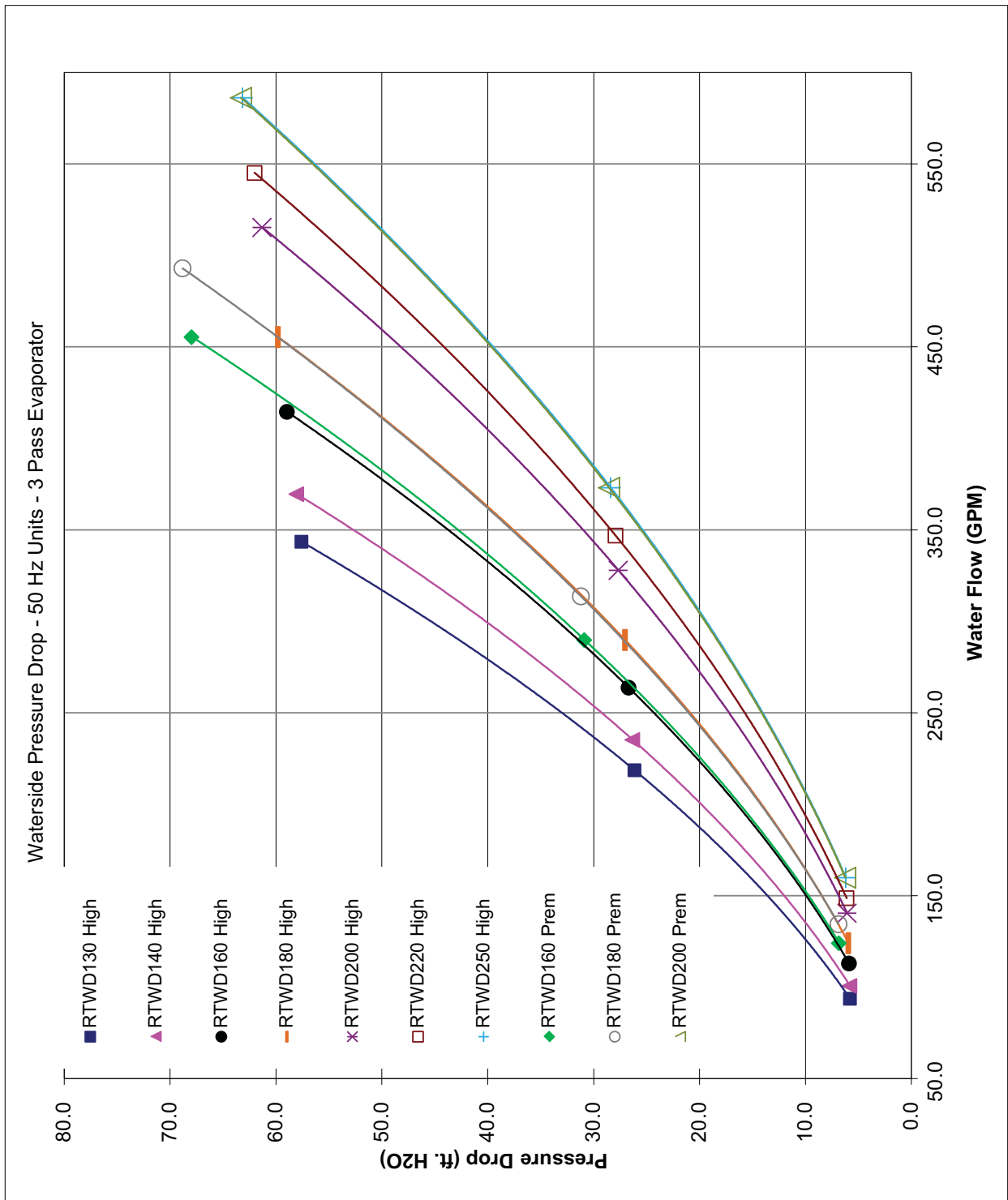

Figure 28. Evaporator pressure drop curves - 3 pass, 50 Hz - RTWD



# Installation - Mechanical

Figure 29. Condenser pressure drop curves - RTWD 60 Hz

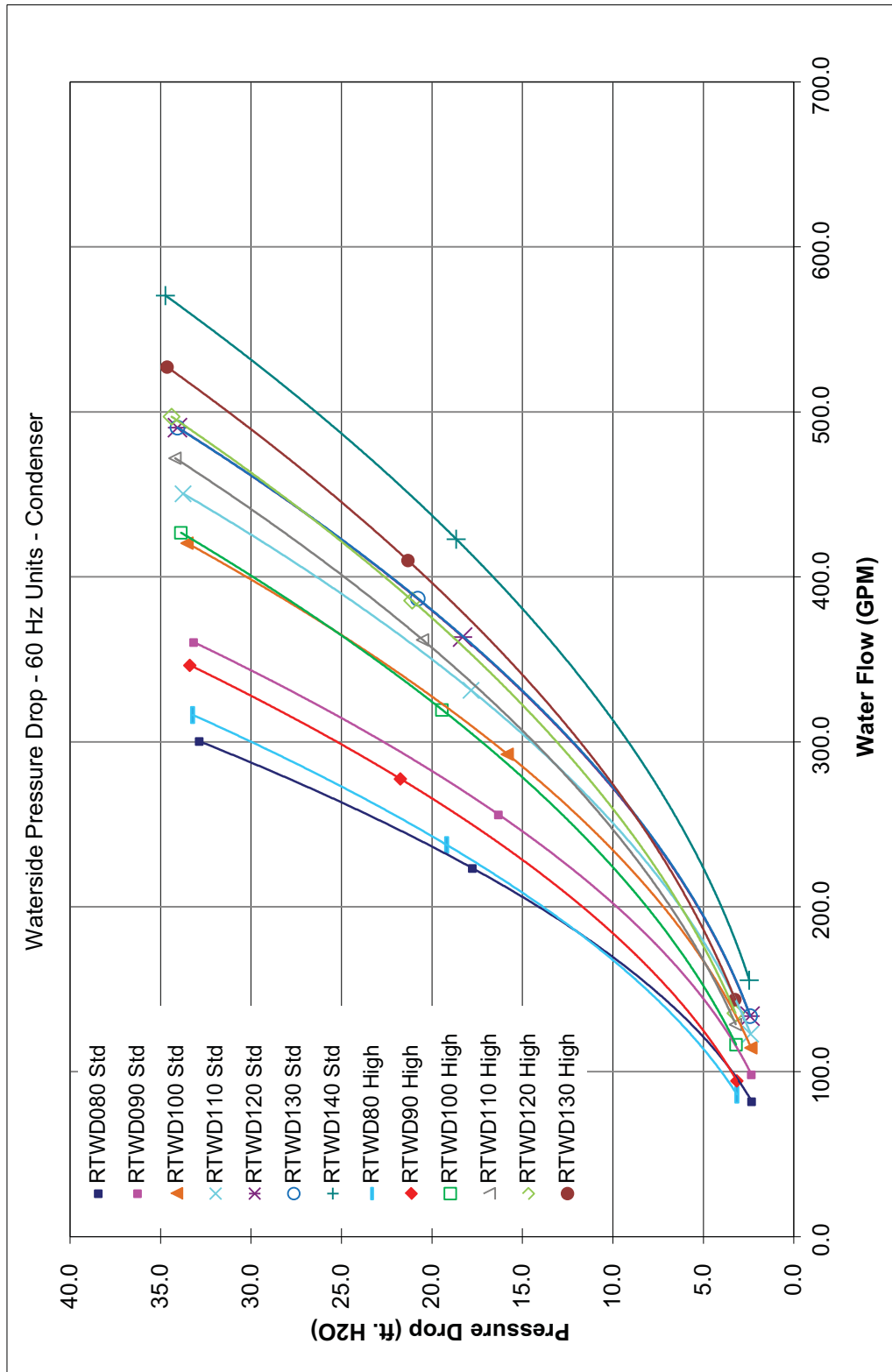
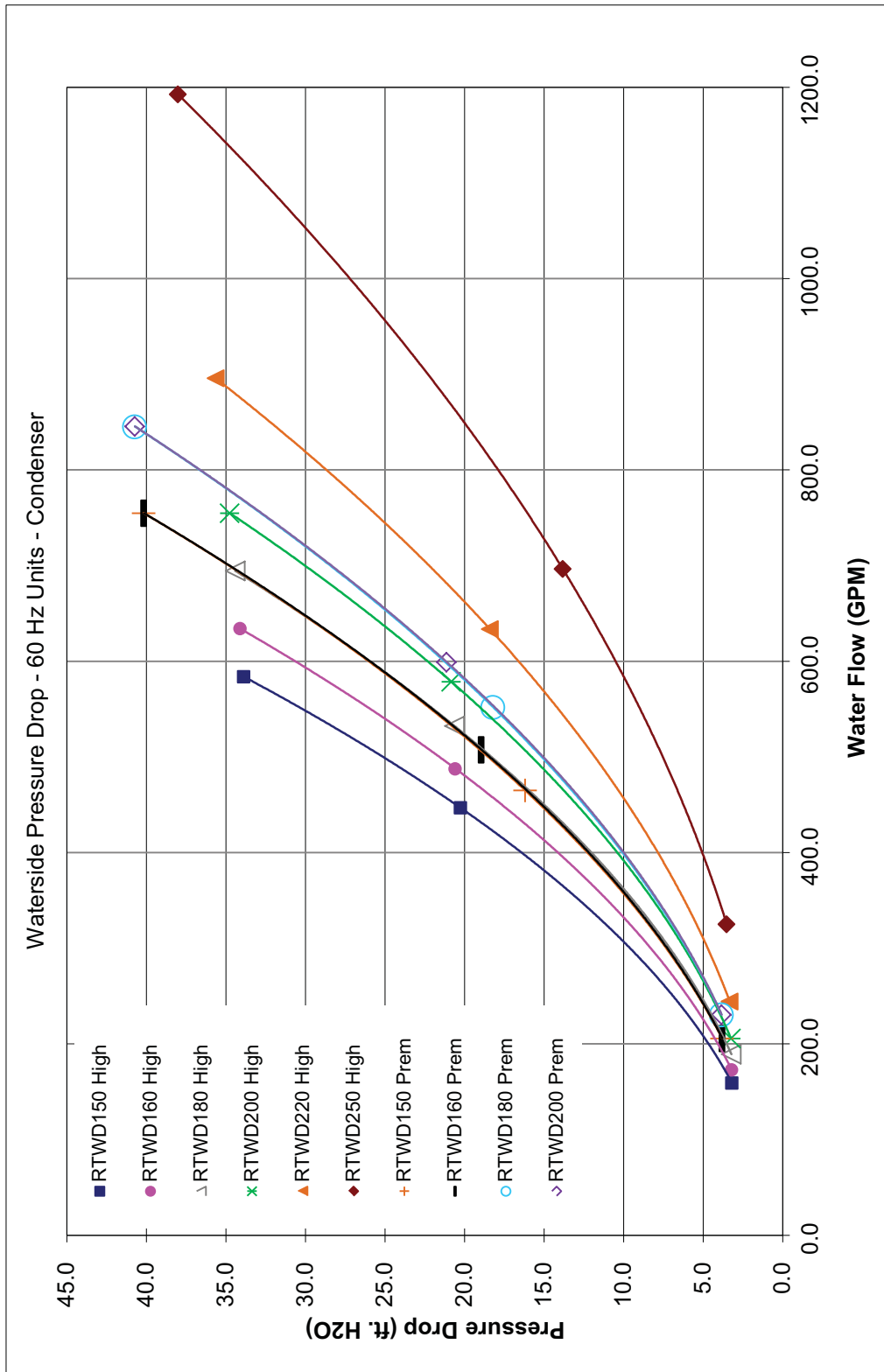

Figure 30. Condenser pressure drop curves - RTWD 60 Hz



# Installation - Mechanical

Figure 31. Condenser pressure drop curves - RTWD 50 Hz

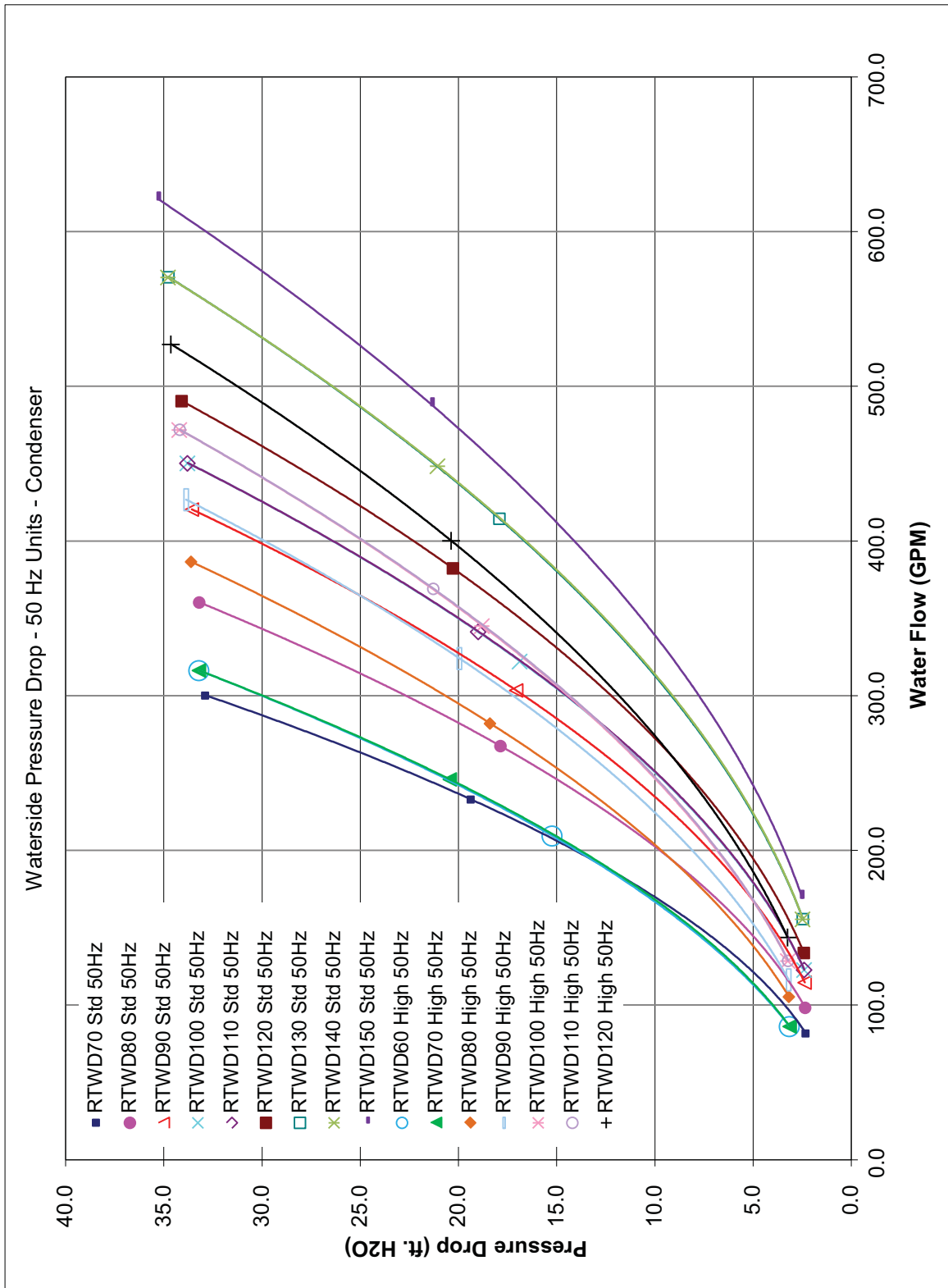
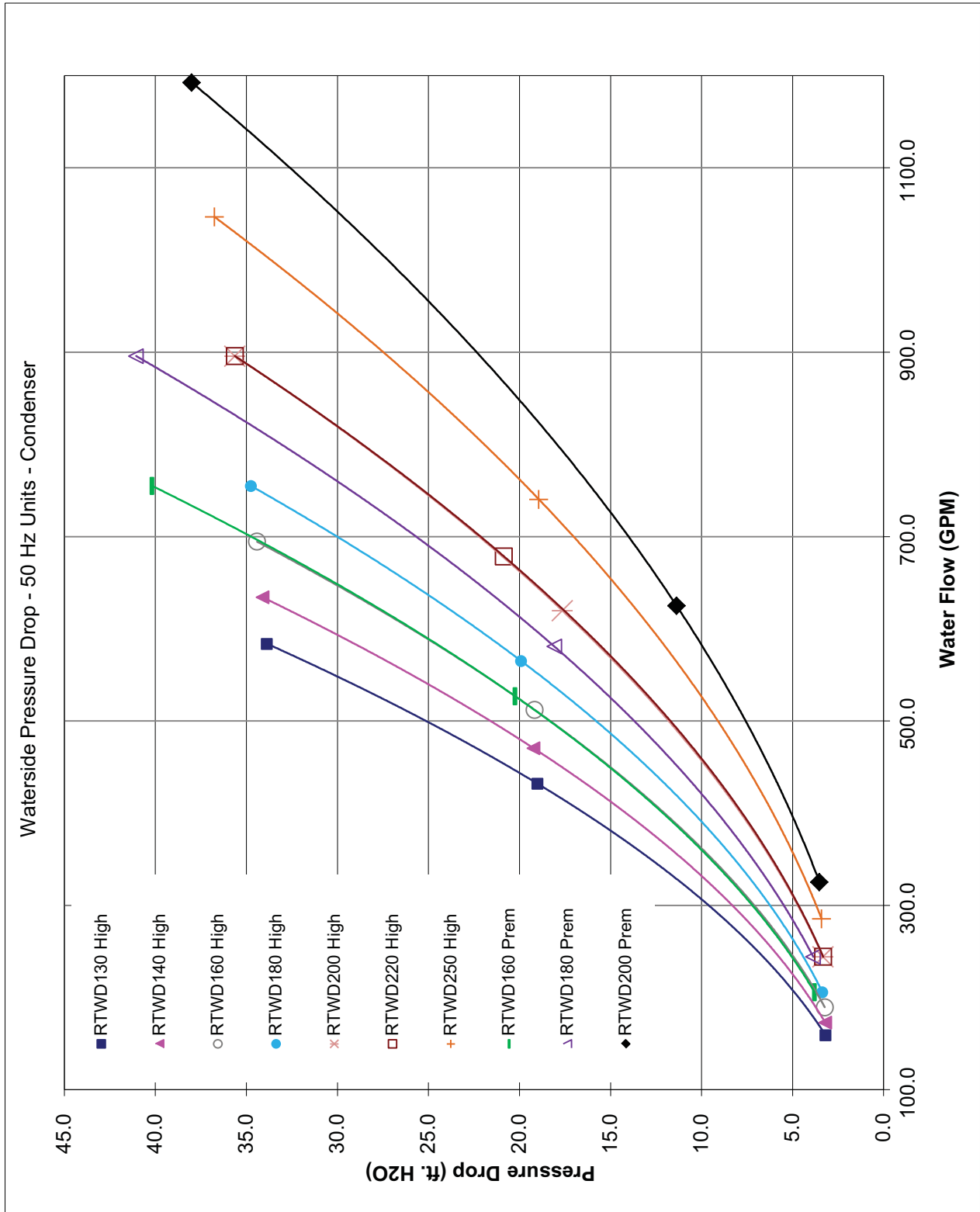

Figure 32. Condenser pressure drop curves - RTWD 50 Hz



## Installation - Mechanical

### Low Evap Refrigerant Cutout/Percent Glycol Recommendations

The table below shows the low evaporator temperature cutout for different glycol levels.

Additional glycol beyond the recommendations will adversely effect unit performance. The unit efficiency will be reduced and the saturated evaporator temperature will

be reduced. For some operating conditions this effect can be significant.

If additional glycol is used, then use the actual percent glycol to establish the low refrigerant cutout setpoint.

**Table 36. Low evaporator refrigerant temperature cutout (LRTC) and low water temperature cutout (LWTC)**

Ethylene Glycol				Propylene Glycol			
Glycol Percentage (%)	Solution Freeze Point (°F)	Minimum Recommended LRTC (°F)	Minimum Recommended LWTC (°F)	Glycol Percentage (%)	Solution Freeze Point (°F)	Minimum Recommended LRTC (°F)	Minimum Recommended LWTC (°F)
0	32.0	28.6	35.0	0	32.0	28.6	35.0
2	31.0	27.6	34.0	2	31.0	27.6	34.0
4	29.7	26.3	32.7	4	29.9	26.5	32.9
5	29.0	25.6	32.0	5	29.3	25.9	32.3
6	28.3	24.9	31.3	6	28.7	25.3	31.7
8	26.9	23.5	29.9	8	27.6	24.2	30.6
10	25.5	22.1	28.5	10	26.4	23.0	29.4
12	23.9	20.5	26.9	12	25.1	21.7	28.1
14	22.3	18.9	25.3	14	23.8	20.4	26.8
15	21.5	18.1	24.5	15	23.1	19.7	26.1
16	20.6	17.2	23.6	16	22.4	19.0	25.4
18	18.7	15.3	21.7	18	20.9	17.5	23.9
20	16.8	13.4	19.8	20	19.3	15.9	22.3
22	14.7	11.3	17.7	22	17.6	14.2	20.6
24	12.5	9.1	15.5	24	15.7	12.3	18.7
25	11.4	8.0	14.4	25	14.8	11.4	17.8
26	10.2	6.8	13.2	26	13.8	10.4	16.8
28	7.7	4.3	10.7	28	11.6	8.2	14.6
30	5.1	1.7	8.1	30	9.3	5.9	12.3
32	2.3	-1.1	5.3	32	6.8	3.4	9.8
34	-0.7	-4.1	5.0	34	4.1	0.7	7.1
35	-2.3	-5.0	5.0	35	2.7	-0.7	5.7
36	-3.9	-5.0	5.0	36	1.3	-2.1	5.0
38	-7.3	-5.0	5.0	38	-1.8	-5.0	5.0
40	-10.8	-5.0	5.0	40	-5.2	-5.0	5.0
42	-14.6	-5.0	5.0	42	-8.8	-5.0	5.0
44	-18.6	-5.0	5.0	44	-12.6	-5.0	5.0
45	-20.7	-5.0	5.0	45	-14.6	-5.0	5.0
46	-22.9	-5.0	5.0	46	-16.7	-5.0	5.0
48	-27.3	-5.0	5.0	48	-21.1	-5.0	5.0
50	-32.1	-5.0	5.0	50	-25.8	-5.0	5.0

## Condenser Water Piping (RTWD Units Only)

Condenser water inlet and outlet types, sizes and locations are given in the Unit Dimensions and Weights. Condenser pressure drops are shown in [Figure 29, p. 51](#) thru [Figure 32, p. 54](#).

### Condenser Piping Components

Condenser piping components and layout vary, depending on location of connections and water source.

Condenser piping components generally function identically to those in the evaporator piping system, as described in "[Evaporator Piping](#)" on [Page 40](#). In addition, cooling tower systems should include a manual or automatic bypass valve that can alter the water flow rate, to maintain condensing pressure. Well water (or city water) condensing systems should include a pressure reducing valve and a water regulating valve.

Pressure reducing valve should be installed to reduce water pressure entering the condenser. This is required only if the water pressure exceeds 150 psig. This is necessary to prevent damage to the disc and seat of the water regulating valve that can be caused by excessive pressure drop through the valve and also due to the design of the condenser. Condenser waterside is rated at 150 psi.

#### **NOTICE:**

##### **Equipment Damage!**

To prevent damage to the condenser or regulating valve, the condenser water pressure should not exceed 150 psig.

### Water Regulating Valve (RTWD Only)

The Condenser Head Pressure Control Option provides for a 0-10V (maximum range - a smaller range is adjustable) output interface to the customer's condenser water flow device. Refer to RLC-PRB021-EN for further details regarding condenser water temperature control.

The following guidelines must be met in order to ensure adequate oil circulation throughout the system.

- The RTWD requires a minimum pressure differential of 25 psid (172.1 kPA) at all load conditions in order to ensure adequate oil circulation.
- The entering condenser water temperature must be above 55°F (12.8°C), or between 45°F (7.2°C) and 55°F (12.8°C) with a 1°F (0.6°C) temperature rise per minute up to 55°F (12.8°C).
- The leaving condenser water temperature must be 17°F (9.4°C) degrees higher than leaving evaporator water temperature within 2 minutes of startup. A 25°F (13.9°C) temperature differential must be maintained thereafter. (This differential requirement is lessened by 0.25°F [0.14°C] for every 1°F [0.6°C] that the leaving condenser water temperature is above 55°F [12.8°C].)

If the above guidelines cannot be met, then some form of condenser water temperature control must be used.

Note: Plugged tees are installed to provide access for chemical cleaning of the condenser tubes.

Condenser piping must be in accordance with all applicable local and national codes.

### Condenser Drains

The condenser shells can be drained by removing the drain plugs from the bottom of the condenser heads. Also, remove the vent plugs at the top of the condenser heads to facilitate complete drainage.

When the unit is shipped, the drain plugs are removed from the condenser and placed in a plastic bag in the control panel, along with the evaporator drain plug. The condenser drains may be connected to suitable drains to permit drainage during unit servicing. If they are not, the drain plugs must be installed.

### Water Treatment

Using untreated or improperly treated water in these units may result in inefficient operation and possible tube damage. Consult a qualified water treatment specialist to determine whether treatment is needed. The following disclamatory label is provided on each RTWD unit:

#### **NOTICE:**

##### **Proper Water Treatment!**

The use of untreated or improperly treated water could result in scaling, erosion, corrosion, algae or slime. It is recommended that the services of a qualified water treatment specialist be engaged to determine what water treatment, if any, is required. Trane assumes no responsibility for equipment failures which result from untreated or improperly treated water, or saline or brackish water.

### Water Pressure Gauges

Install field-supplied pressure gauges (with manifolds, when practical) on the RTWD units. Locate pressure gauges or taps in a straight run of pipe; avoid placement near elbows, etc. Install gauges at the same elevation.

To read manifolded pressure gauges, open one valve and close the other (depending upon the reading desired). This eliminates errors resulting from differently calibrated gauges installed at unmatched elevations.

### Water Pressure Relief Valves

Install a water pressure relief valve in the condenser and evaporator leaving chilled water piping. Water vessels with close coupled shutoff valves have a high potential for hydrostatic pressure buildup on a water temperature increase. Refer to applicable codes for relief valve installation guidelines.



## Refrigerant Relief Valve Venting

### ⚠ WARNING

#### Refrigerant under High Pressure!

System contains oil and refrigerant under high pressure. Recover refrigerant to relieve pressure before opening the system. See unit nameplate for refrigerant type. Do not use non-approved refrigerants, refrigerant substitutes, or refrigerant additives. Failure to recover refrigerant to relieve pressure or the use of non-approved refrigerants, refrigerant substitutes, or refrigerant additives could result in an explosion which could result in death or serious injury or equipment damage.

### NOTICE:

#### Equipment Damage!

To prevent shell damage, install pressure relief valves in both the evaporator and condenser water systems.

### NOTICE:

#### Equipment Damage!

To prevent capacity reduction and relief valve damage, do not exceed vent piping code specifications.

### High Pressure Side Relief Valve Venting (RTWD-Condenser, RTUD-Oil Separator)

All RTWD units utilize a refrigerant-pressure relief valve for each circuit which must be vented to the outdoor atmosphere. The valves are located at the top of the condenser. Relief valve connections are 5/8" MFL. See [Figure 33](#). Refer to local codes for relief valve vent line sizing requirements.

All RTUD units utilize a refrigerant-pressure relief valve for each circuit which must be vented to the outdoor atmosphere. The valves are located at the top of the oil separator. Relief valve connections are 3/8" MFL. Refer to local codes for relief valve vent line sizing requirements.

High side relief valve discharge setpoints are 300 psig for RTWD, and 350 psig for RTUD units. Once the relief valve has opened, it will reclose when pressure is reduced to a safe level.

Figure 33. High pressure side relief valves

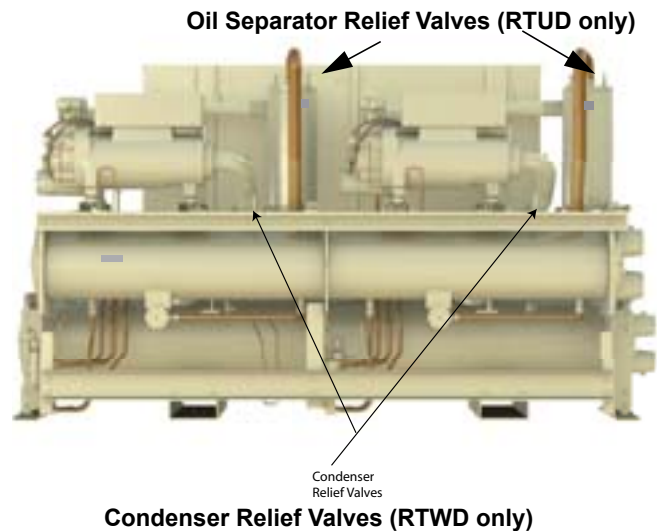

Note: Vent line length must not exceed code recommendations. If the line length will exceed code recommendations for the outlet size of the valve, install a vent line of the next larger pipe size.

Pipe each relief valve on the unit into a common vent line. Provide access valve located at the low point of the vent piping, to enable draining of any condensate that may accumulate in the piping.

If multiple chillers are installed, each unit may have a separate venting for its relief valves. If multiple relief valves are vented together, see ASHRAE 15, and/or local codes for sizing requirements.

Note: RTWD units can be ordered with "Dual Relief Valve" options. Model number digit 16 is a "2". Units with this option will have two valves on each circuit for a total of four on the condenser. Only two valves would release at the same time - never all four.

### Low Pressure Side Relief Valve Venting (Evaporator)

Low-side refrigerant-pressure relief valves are located on the top of the evaporator shell, one per circuit. Each must be vented to the outdoor atmosphere. Relief valve connections are 3/4" NPTFI.

Note: RTWD units can be ordered with "Dual Relief Valve" option. Model number digit 16 is a "2". Units with this option will have two valves on each circuit for a total of four on the evaporator. Only two valves would release at the same time - never all four.

See [Figure 33, p. 57](#) and [Table 37, p. 58](#). Refer to local codes for relief valve vent line sizing requirements.

**Figure 34. Evaporator relief valves**

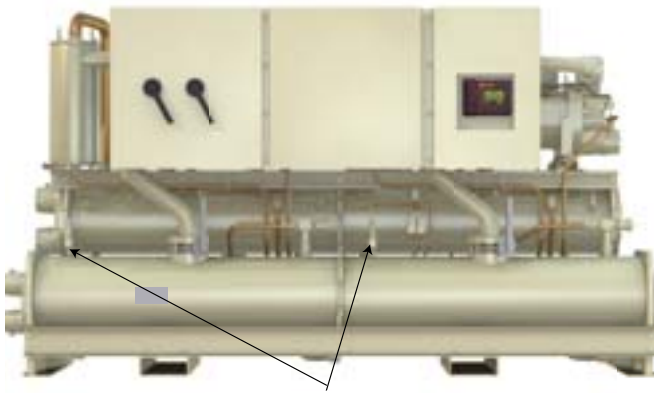

**Evaporator Relief Valves**

Note: Vent line length must not exceed code recommendations. If the line length will exceed code recommendations for the outlet size of the valve, install a vent line of the next larger pipe size.

Low side relief valve discharge setpoints are 200 psig. Once the relief valve has opened, it will reclose when pressure is reduced to a safe level.

Pipe each relief valve on the unit into a common vent line. Provide an access valve located at the low point of the vent piping, to enable draining of any condensate that may accumulate in the piping.

**Summary or Relief Valves - RTWD, RTUD**

**Table 37. Relief valve descriptions**

	<b>Condenser</b>	<b>Evaporator</b>	<b>Oil Separator</b>
Units	RTWD High Pressure Side	RTWD, RTUD Low Pressure Side	RTUD High Pressure Side
Relief Setpoint	300 psig	200 psig	350 psig
Quantity (standard)	1 per ckt	1 per ckt	1 per ckt
Quantity (Dual Relief Valves option - RTWD only)	2 per ckt	RTWD - 2 per ckt (n/a - RTUD units)	n/a
Relief Rate (lb/min)	25.4	28.9	13.3
Field Connection Size	5/8" MFL	3/4" NPTFI	3/8" MFL

**RTUD Installation**

The installation of a split system offers a good economic alternative to satisfy the chilled water demand for cooling a building, particularly in the case of new construction.

The choice of a complete Trane system, including the compressor chiller and the condenser offers the designer, installer and owner the advantages of an optimized selection and undivided responsibility for the design, the quality and the operation of the complete system.

**Application examples**

**No Elevation Difference**

See [Figure 35, p. 59.](#)

**Restrictions**

- Total distance between components should not exceed 200 ft (actual) or 300 ft (equivalent).
- Elevation rise of the liquid line must not be more than 15 ft above the base of the air-cooled condenser.
- Discharge line trap is recommended leaving the oil separator if the discharge piping runs for more than 10 (actual) feet horizontally above the RTUD unit.

**Condenser Installed Above Compressor Chiller**

See [Figure 36, p. 59.](#)

**Restrictions**

- Total distance between components should not exceed 200 ft (actual) or 300 ft (equivalent).
- Elevation difference greater than 100 ft (actual) will result in at least a 2% efficiency decrease.

**Condenser Installed Below Compressor Chiller**

See [Figure 37, p. 60.](#)

**Restrictions**

- Total distance between components should not exceed 200 ft (actual) or 300 ft (equivalent).
- Elevation rise of the liquid line must not be more than 15 ft above the base of the air-cooled condenser.

## Installation - Mechanical

**Figure 35. Condenser installed at same elevation as compressor chiller**

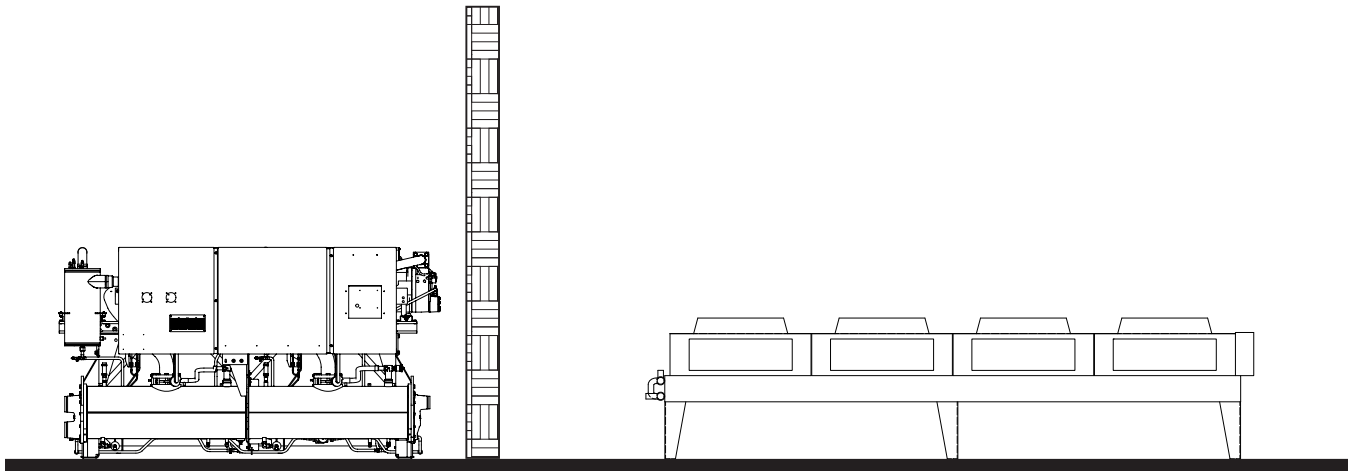

**Figure 36. Condenser above the compressor chiller**

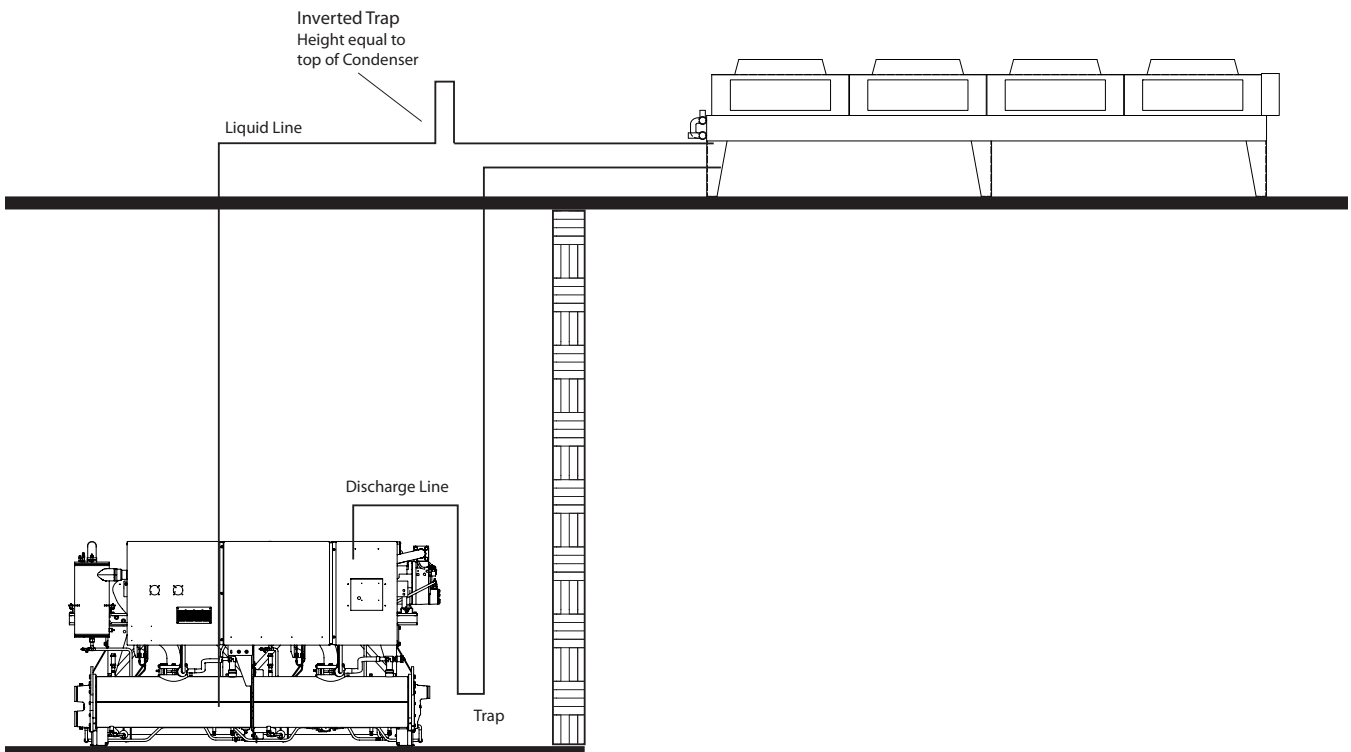

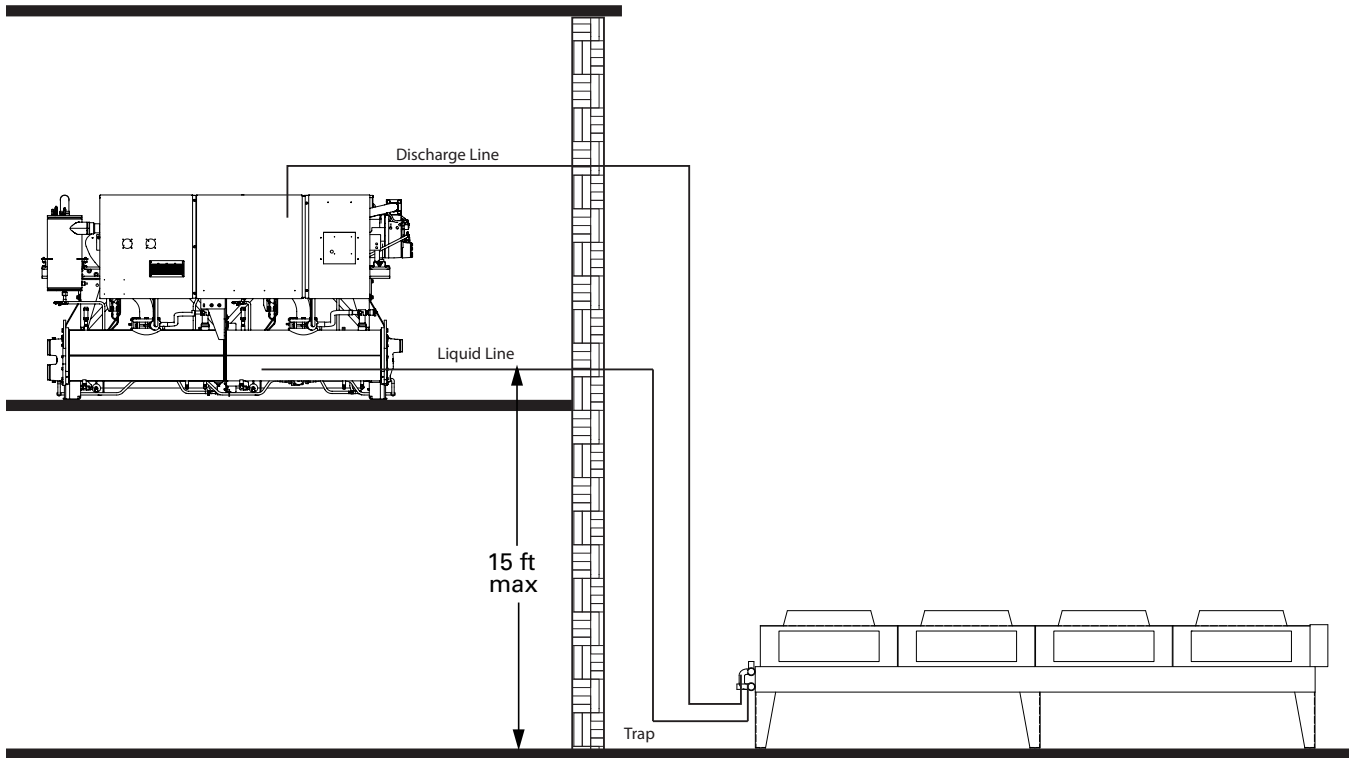
**Figure 37. Condenser below the compressor chiller**

### Remote Air-Cooled Condenser Interconnection Refrigerant Piping

The RTUD compressor chiller is shipped with a full charge of oil and a nitrogen holding charge. The Levitor II unit is an air-cooled condenser that is designed for use with the RTUD unit. The RTUD unit is designed to be most effective when used with the Levitor II aircooled condenser. Other air-cooled condensers can be used in place of the Levitor II condenser, but the overall performance of the system may be different from that published in the catalogs. The following section covers the required piping between the RTUD unit and the appropriate air-cooled condenser.

The RTUD unit consists of an evaporator, two helical rotor compressors (one per circuit), oil separators, oil coolers, liquid line service valves (NOT isolation valves), sight glasses, electronic expansion valves and filter. The discharge line leaving the oil separator and liquid line entering the filters are capped and brazed. The installing contractor need only provide the interconnecting piping, including liquid line isolation valves, between the RTUD and the air-cooled condenser.

**Important:** RTUD units are not shipped with factory installed liquid line isolation valves. Liquid line isolation valves must be field installed.

Trane does not approve the use of underground refrigerant piping. Potential problems include dirt and moisture in the lines during assembly, condensation of refrigerant in the lines during off-cycle, which creates

liquid slugs and potential damage to parts or controllability issues, and vibration/corrosion damage.

For best reliability and performance, the RTUD should be matched with Trane Levitor II. If a non-Levitor II condenser is used, overall performance and reliability of the RTUD may be affected. Depending on the customer's fan control, nuisance trips may occur on the RTUD unit, due to head pressure instability.

If a non-Levitor II condenser is a supplied, it must be capable of providing a minimum of 5 F subcooling at the EXV. The RTUD requires subcooled liquid at the expansion valves. Without a minimum of 5 F subcooling, the RTUD will not operate as designed.

Piping should be sized and laid out according to the job plans and specifications. This design should be completed during system component selection.

**Note:** Use Type L refrigerant-grade copper tubing only.

The refrigerant lines must be isolated to prevent line vibration from being transferred to the building. Do not secure the lines rigidly to the building at any point.

**Important:** Relieve nitrogen pressure before removing end caps.

## Installation - Mechanical

Do not use a saw to remove end caps, as this may allow copper chips to contaminate the system. Use a tubing cutter or heat to remove end caps.

### ⚠ WARNING

#### Hazard of Explosion!

When sweating line connections, always provide a sufficient purge of dry nitrogen through the tubing to prevent the formation of oxides/scaling caused by high temperature from brazing. Use a pressure regulator in the line between the unit and the high pressure nitrogen cylinder to avoid over-pressurization and possible explosion. If any refrigerant or refrigerant vapors are present a thorough purge with dry nitrogen will prevent the possible formation of toxic phosgene gas. Failure to follow these recommendations could result in death or serious injury.

See [Table 38, p. 61](#) for the Levitor condenser model number. Units 150 tons and above will have one condenser per circuit. The manifold piping for these condensers is field supplied.

**Table 38. Levitor Model Numbers**

RTUD Size	Circuit (s)	Levitor Model No.
80 Ton	Ckt 1 & 2	LAVC23312
90 Ton	Ckt 1 & 2	LAVC24310
100 Ton	Ckt 1 & 2	LAVC24410
110 Ton	Ckt 1 & 2	LAVC24412
120 Ton	Ckt 1 & 2	LAVC25408
130 Ton	Ckt 1 & 2	LAVC25410
150 Ton	Ckt 1	LAVC23308
150 Ton	Ckt 2	LAVC23312
160 Ton	Ckt 1	LAVC23312
160 Ton	Ckt 2	LAVC23312
180 Ton	Ckt 1	LAVC23312
180 Ton	Ckt 2	LAVC24308
200 Ton	Ckt 1	LAVC24308
200 Ton	Ckt 2	LAVC24308
220 Ton	Ckt 1	LAVC24308
220 Ton	Ckt 2	LAVC24410
250 Ton	Ckt 1	LAVC24410
250 Ton	Ckt 2	LAVC24410

On units with two separate Trane-supplied condensers (150-250 Ton), a field installed tee is required at the condenser connections to combine the two internal halves into a single circuit. See [Figure 39, p. 61](#). In this case, each separate condenser would be a single circuit. If non-Trane condensers with multiple circuits are used, a field installed tee may be required to provide two individual circuits.

**Important:** To prevent excessive pressure drop in tee, connection for the combined stream should not be any smaller than the field run piping.

**Figure 38. Condenser manifolding, 80-130Ton**

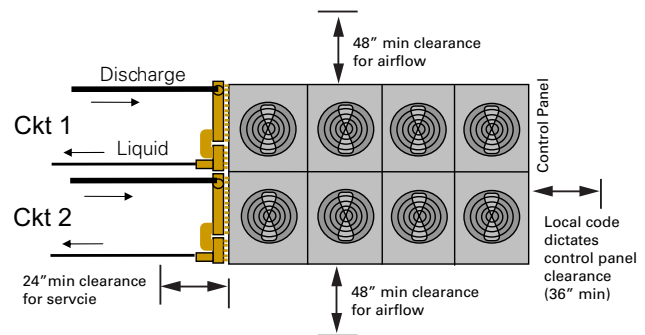

**Figure 39. Condenser manifolding, 150-250Ton**

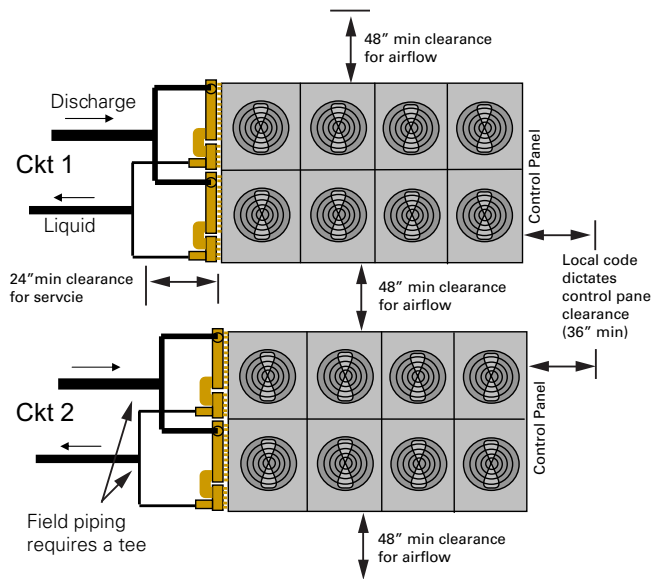

### Condenser by Others Requirement for Stable fan operation at low ambient temperatures

Each circuit of the RTUD chiller is capable of unloading to approximately 30% of its full load capability at any given operating point. To guarantee no fan cycling at the minimum compressor load and an ambient temperature of 32°, the condenser will require the ability to reduce its minimum capacity with one fan running to roughly 1/2 of that 30%, which implies at least 6 fans minimum. Some amount of slow fan cycling is acceptable depending on the application. Operating with fewer fans at low ambient temperatures and minimum loads may cause fast and prolonged fan cycling and may result in large excursions in condenser pressure and differential pressures and may lead to either poor leaving water temperature performance or nuisance tripping. To avoid this problem in certain low ambient temperature applications, it may be necessary to provide that one fan be a variable speed fan to improve stability and minimal cycling.

## System Configuration

The system can be configured in any of the primary arrangements as shown in [Figure 35, p. 59](#), [Figure 36, p. 59](#) and [Figure 37, p. 60](#). The configuration and its associated elevation, along with the total distance between the RTUD and the air-cooled condenser, plays a critical role in determining the liquid line and discharge line sizes. This will also affect the field refrigerant and oil charges. Consequently, there are physical limits which must not be violated if the system is to operate as designed. Please note the following restrictions:

1. The discharge line sizing is different for different leaving evaporator water temperatures.
2. The total distance between the RTUD and the air-cooled condenser must not exceed 200 actual feet or 300 equivalent feet.
3. When the air-cooled condenser is installed at the same level or below the compressor-chiller, liquid line risers must not be more than 15 ft above the base of the condenser.
4. Discharge line risers cannot exceed an elevation difference greater than 100 actual feet without a minimum of 2% efficiency decrease.
5. See [Figure 35](#), [Figure 36](#) and [Figure 37](#). for location of recommended traps.
6. Circuit #1 on the condenser must be connected to Circuit # 1 on the RTUD unit.

### **NOTICE:**

#### **Equipment Damage!**

**If circuits are crossed, serious equipment damage may occur.**

### Equivalent Line Length

To determine the appropriate size for field installed liquid and discharge lines, it is first necessary to establish the equivalent length of pipe for each line, including the added flow resistance of elbows, valves, etc. An initial approximation can be made by assuming that the equivalent length of pipe is 1.5 times the actual pipe length.

Note: [Table 39, p. 62](#) states the equivalent length, in feet, for various non-ferrous valves and fittings. When calculating the equivalent length, do not include piping of the unit. Only field piping must be considered.

**Table 39. Equivalent lengths of non-ferrous valves and fittings**

Line Size OD (in)	Globe Valve (ft)	Angle Valve (ft)	Short Radius Elbow (ft)	Long Radius Elbow (ft)
1 1/8	87	29	2.7	1.9
1 3/8	102	33	3.2	2.2
1 5/8	115	34	3.8	2.6
2 1/8	141	39	5.2	3.4
2 5/8	159	44	6.5	4.2
3 1/8	185	53	8	5.1
3 5/8	216	66	10	6.3
4 1/8	248	76	12	7.3

### Liquid Line Sizing

Trane recommends that the liquid line diameter be as small as possible, while maintaining acceptable pressure drop. This is necessary to minimize refrigerant charge. The total length between the components must not exceed 200 actual feet or 300 equivalent feet.

The liquid line risers must not exceed 15 feet from the base of the air-cooled condenser. The liquid line does not have to be pitched. Liquid line sizing for these units when installed with a Trane Levitor II air-cooled condenser are shown in [Table 40, p. 63](#) through [Table 51, p. 66](#). Line sizing for other condensers must be done manually not to violate the 5°F subcooling requirement at the EXV.

Liquid lines are not typically insulated. However, if the lines run through an area of high ambient temperature (eg. boiler room), subcooling may drop below required levels. In these situations, insulate the liquid lines.

Use of a liquid line receiver is not recommended because it adds to the overall refrigerant volume of the circuit.

Note: In case of power failure to the expansion valve, the amount of liquid refrigerant contained in the refrigerant system must not exceed the holding capacity of the evaporator. See [Table 64, p. 71](#) for the maximum allowable charge in each circuit.

Note: Height in [Table 40](#) through [Table 51](#) is the raise in elevation of the RTUD unit above the condensing unit.





**Installation - Mechanical**

**Table 43. Liquid line sizing RTUD 110 ton**

		Height (ft)					
Ckt 1 Line	< 0	3	6	9	12	15	
Total Equiv. Length (ft)	25	1.125	1.125	1.125	1.125	1.125	1.125
	50	1.125	1.125	1.125	1.125	1.125	1.125
	75	1.125	1.125	1.125	1.125	1.125	1.125
	100	1.125	1.125	1.125	1.125	1.125	1.125
	125	1.125	1.125	1.125	1.125	1.125	1.125
	150	1.125	1.125	1.125	1.125	1.125	1.125
	175	1.125	1.125	1.125	1.125	1.375	1.375
	200	1.125	1.125	1.125	1.375	1.375	1.375
	225	1.125	1.375	1.375	1.375	1.375	1.375
	250	1.375	1.375	1.375	1.375	1.375	1.375
	275	1.375	1.375	1.375	1.375	1.375	1.375
	300	1.375	1.375	1.375	1.375	1.375	1.375
Ckt 2 Line	< 0	3	6	9	12	15	
Total Equiv. Length (ft)	25	1.125	1.125	1.125	1.125	1.125	1.125
	50	1.125	1.125	1.125	1.125	1.125	1.125
	75	1.125	1.125	1.125	1.125	1.125	1.125
	100	1.125	1.125	1.125	1.125	1.125	1.125
	125	1.125	1.125	1.125	1.125	1.125	1.125
	150	1.125	1.125	1.125	1.125	1.125	1.125
	175	1.125	1.125	1.125	1.125	1.125	1.375
	200	1.125	1.125	1.125	1.375	1.375	1.375
	225	1.125	1.125	1.375	1.375	1.375	1.375
	250	1.375	1.375	1.375	1.375	1.375	1.375
	275	1.375	1.375	1.375	1.375	1.375	1.375
	300	1.375	1.375	1.375	1.375	1.375	1.375

**Table 44. Liquid line sizing RTUD 120 ton**

		Height (ft)					
Ckt 1 Line	< 0	3	6	9	12	15	
Total Equiv. Length (ft)	25	1.125	1.125	1.125	1.125	1.125	1.125
	50	1.125	1.125	1.125	1.125	1.125	1.125
	75	1.125	1.125	1.125	1.125	1.125	1.375
	100	1.125	1.125	1.125	1.375	1.375	1.375
	125	1.125	1.125	1.375	1.375	1.375	1.375
	150	1.375	1.375	1.375	1.375	1.375	1.375
	175	1.375	1.375	1.375	1.375	1.375	1.625
	200	1.375	1.375	1.375	1.375	1.375	1.625
	225	1.375	1.375	1.375	1.375	1.625	1.625
	250	1.375	1.375	1.375	1.375	1.625	1.625
	275	1.375	1.375	1.375	1.625	1.625	1.625
	300	1.375	1.375	1.375	1.625	1.625	1.625

**Table 44. Liquid line sizing RTUD 120 ton (continued)**

		Height (ft)					
Ckt 2 Line	< 0	3	6	9	12	15	
Total Equiv. Length (ft)	25	1.125	1.125	1.125	1.125	1.125	1.125
	50	1.125	1.125	1.125	1.125	1.125	1.375
	75	1.125	1.125	1.125	1.375	1.375	1.375
	100	1.125	1.375	1.375	1.375	1.375	1.375
	125	1.375	1.375	1.375	1.375	1.375	1.625
	150	1.375	1.375	1.375	1.375	1.375	1.625
	175	1.375	1.375	1.375	1.375	1.625	1.625
	200	1.375	1.375	1.375	1.375	1.625	1.625
	225	1.375	1.375	1.375	1.625	1.625	1.625
	250	1.375	1.375	1.625	1.625	1.625	1.625
	275	1.375	1.375	1.625	1.625	1.625	1.625
	300	1.375	1.625	1.625	1.625	1.625	2.125

**Table 45. Liquid line sizing RTUD 130 ton**

		Height (ft)					
Ckt 1 Line	< 0	3	6	9	12	15	
Total Equiv. Length (ft)	25	1.125	1.125	1.125	1.125	1.125	1.375
	50	1.125	1.125	1.125	1.375	1.375	1.625
	75	1.125	1.375	1.375	1.375	1.625	1.625
	100	1.375	1.375	1.375	1.375	1.625	2.125
	125	1.375	1.375	1.375	1.625	1.625	2.125
	150	1.375	1.375	1.625	1.625	1.625	2.125
	175	1.375	1.375	1.625	1.625	2.125	2.125
	200	1.375	1.625	1.625	1.625	2.125	2.125
	225	1.625	1.625	1.625	1.625	2.125	2.125
	250	1.625	1.625	1.625	1.625	2.125	2.125
	275	1.625	1.625	1.625	2.125	2.125	2.125
	300	1.625	1.625	1.625	2.125	2.125	2.125
Ckt 2 Line	< 0	3	6	9	12	15	
Total Equiv. Length (ft)	25	1.125	1.125	1.125	1.125	1.125	1.375
	50	1.125	1.125	1.125	1.375	1.375	1.625
	75	1.125	1.375	1.375	1.375	1.375	1.625
	100	1.375	1.375	1.375	1.375	1.625	2.125
	125	1.375	1.375	1.375	1.625	1.625	2.125
	150	1.375	1.375	1.375	1.625	1.625	2.125
	175	1.375	1.375	1.625	1.625	1.625	2.125
	200	1.375	1.625	1.625	1.625	2.125	2.125
	225	1.375	1.625	1.625	1.625	2.125	2.125
	250	1.625	1.625	1.625	1.625	2.125	2.125
	275	1.625	1.625	1.625	2.125	2.125	2.125
	300	1.625	1.625	1.625	2.125	2.125	2.125



## Installation - Mechanical

**Table 46. Liquid line sizing RTUD 150 ton**

		Height (ft)					
Ckt 1 Line		< 0	3	6	9	12	15
Total Equiv. Length (ft)	25	1.125	1.125	1.125	1.125	1.125	1.125
	50	1.125	1.125	1.125	1.125	1.125	1.125
	75	1.125	1.125	1.125	1.125	1.125	1.125
	100	1.125	1.125	1.125	1.125	1.125	1.125
	125	1.125	1.125	1.125	1.125	1.125	1.125
	150	1.125	1.125	1.125	1.125	1.125	1.125
	175	1.125	1.125	1.125	1.125	1.125	1.125
	200	1.125	1.125	1.125	1.125	1.125	1.375
	225	1.125	1.125	1.125	1.375	1.375	1.375
	250	1.125	1.375	1.375	1.375	1.375	1.375
	275	1.375	1.375	1.375	1.375	1.375	1.375
	300	1.375	1.375	1.375	1.375	1.375	1.375
Ckt 2 Line		< 0	3	6	9	12	15
Total Equiv. Length (ft)	25	1.125	1.125	1.125	1.125	1.125	1.125
	50	1.125	1.125	1.125	1.125	1.125	1.125
	75	1.125	1.125	1.125	1.125	1.125	1.125
	100	1.125	1.125	1.125	1.125	1.125	1.125
	125	1.125	1.125	1.125	1.125	1.125	1.125
	150	1.125	1.125	1.125	1.125	1.375	1.375
	175	1.125	1.375	1.375	1.375	1.375	1.375
	200	1.375	1.375	1.375	1.375	1.375	1.375
	225	1.375	1.375	1.375	1.375	1.375	1.375
	250	1.375	1.375	1.375	1.375	1.375	1.375
	275	1.375	1.375	1.375	1.375	1.375	1.375
	300	1.375	1.375	1.375	1.375	1.375	1.375

**Table 47. Liquid line sizing RTUD 160 ton**

		Height (ft)					
Ckt 1 Line		< 0	3	6	9	12	15
Total Equiv. Length (ft)	25	1.375	1.375	1.375	1.375	1.375	1.375
	50	1.375	1.375	1.375	1.375	1.375	1.375
	75	1.375	1.375	1.375	1.375	1.375	1.375
	100	1.375	1.375	1.375	1.375	1.375	1.375
	125	1.375	1.375	1.375	1.375	1.375	1.375
	150	1.375	1.375	1.375	1.375	1.375	1.375
	175	1.375	1.375	1.375	1.375	1.375	1.375
	200	1.375	1.375	1.375	1.375	1.375	1.375
	225	1.375	1.375	1.375	1.375	1.375	1.375
	250	1.375	1.375	1.375	1.375	1.375	1.375
	275	1.375	1.375	1.375	1.375	1.375	1.375
	300	1.375	1.375	1.375	1.375	1.375	1.375

**Table 47. Liquid line sizing RTUD 160 ton (continued)**

		Height (ft)					
Ckt 2 Line		< 0	3	6	9	12	15
Total Equiv. Length (ft)	25	1.375	1.375	1.375	1.375	1.375	1.375
	50	1.375	1.375	1.375	1.375	1.375	1.375
	75	1.375	1.375	1.375	1.375	1.375	1.375
	100	1.375	1.375	1.375	1.375	1.375	1.375
	125	1.375	1.375	1.375	1.375	1.375	1.375
	150	1.375	1.375	1.375	1.375	1.375	1.375
	175	1.375	1.375	1.375	1.375	1.375	1.375
	200	1.375	1.375	1.375	1.375	1.375	1.375
	225	1.375	1.375	1.375	1.375	1.375	1.375
	250	1.375	1.375	1.375	1.375	1.375	1.375
	275	1.375	1.375	1.375	1.375	1.375	1.375
	300	1.375	1.375	1.375	1.375	1.375	1.375

**Table 48. Liquid line sizing RTUD 180 ton**

		Height (ft)					
Ckt 1 Line		< 0	3	6	9	12	15
Total Equiv. Length (ft)	25	1.375	1.375	1.375	1.375	1.375	1.375
	50	1.375	1.375	1.375	1.375	1.375	1.375
	75	1.375	1.375	1.375	1.375	1.375	1.375
	100	1.375	1.375	1.375	1.375	1.375	1.375
	125	1.375	1.375	1.375	1.375	1.375	1.375
	150	1.375	1.375	1.375	1.375	1.375	1.375
	175	1.375	1.375	1.375	1.375	1.375	1.375
	200	1.375	1.375	1.375	1.375	1.375	1.375
	225	1.375	1.375	1.375	1.375	1.375	1.375
	250	1.375	1.375	1.375	1.375	1.375	1.375
	275	1.375	1.375	1.375	1.375	1.375	1.375
	300	1.375	1.375	1.375	1.375	1.375	1.375
Ckt 2 Line		< 0	3	6	9	12	15
Total Equiv. Length (ft)	25	1.375	1.375	1.375	1.375	1.375	1.375
	50	1.375	1.375	1.375	1.375	1.375	1.375
	75	1.375	1.375	1.375	1.375	1.375	1.375
	100	1.375	1.375	1.375	1.375	1.375	1.375
	125	1.375	1.375	1.375	1.375	1.375	1.375
	150	1.375	1.375	1.375	1.375	1.375	1.375
	175	1.375	1.375	1.375	1.375	1.375	1.625
	200	1.375	1.375	1.375	1.375	1.625	1.625
	225	1.375	1.375	1.375	1.625	1.625	1.625
	250	1.375	1.375	1.625	1.625	1.625	1.625
	275	1.375	1.625	1.625	1.625	1.625	1.625
	300	1.625	1.625	1.625	1.625	1.625	1.625



## Installation - Mechanical

### Discharge (Hot Gas) Line Sizing

The discharge lines should pitch downward, in the direction of the hot gas flow, at the rate of 1/2 inch per each 10 feet of horizontal run.

Discharge line size is based on the velocity needed to obtain sufficient oil return. Basic discharge line sizing is shown in Table 52, p. 67 through Table 63, p. 70, depending on the unit configuration.

Discharge lines are not typically insulated. If insulation is required, it should be approved for use at temperatures up to 230°F (max discharge temp).

Note: The proper column for leaving evaporator water temperature must be used to avoid catastrophic damage to the unit. Column for 10 °F to 37°F can only be used on units designed for low temperature applications. Refer to the design conditions of the unit to determine the correct column that must be used.

Note: The discharge line should drop well below the compressor discharge outlet before beginning its vertical rise. This prevents possible refrigerant drainage back to the compressor and oil separator during the unit STOP cycle. See Figure 35, p. 59, Figure 36, p. 59 and Figure 37, p. 60 for details.

**Table 52. Discharge (hot gas) line sizing RTUD 80 ton**

Ckt 1 Line	Leaving Water Temperature		Ckt 2 Line	Leaving Water Temperature			
	38-65 °F	10-37 °F		38-65 °F	10-37 °F		
Total Equiv. Length (ft)	25	2.125	2.125	Total Equiv. Length (ft)	25	2.125	2.125
	50	2.125	2.125		50	2.125	2.125
	75	2.125	2.125		75	2.125	2.125
	100	2.125	2.125		100	2.125	2.125
	125	2.125	2.125		125	2.125	2.125
	150	2.125	2.125		150	2.125	2.125
	175	2.125	2.125		175	2.125	2.125
	200	2.125	2.125		200	2.125	2.125
	225	2.125	2.125		225	2.125	2.125
	250	2.125	2.125		250	2.125	2.125
	275	2.125	2.125		275	2.125	2.125
	300	2.625	2.125		300	2.625	2.125

**Table 53. Discharge (hot gas) line sizing RTUD 90 ton**

Ckt 1 Line	Leaving Water Temperature		Ckt 2 Line	Leaving Water Temperature			
	38-65 °F	10-37 °F		38-65 °F	10-37 °F		
Total Equiv. Length (ft)	25	2.125	2.125	Total Equiv. Length (ft)	25	2.125	2.125
	50	2.125	2.125		50	2.125	2.125
	75	2.125	2.125		75	2.125	2.125
	100	2.125	2.125		100	2.125	2.125
	125	2.125	2.125		125	2.125	2.125
	150	2.125	2.125		150	2.125	2.125
	175	2.125	2.125		175	2.125	2.125
	200	2.125	2.125		200	2.125	2.125
	225	2.625	2.125		225	2.625	2.125
	250	2.625	2.125		250	2.625	2.125
	275	2.625	2.125		275	2.625	2.125
	300	2.625	2.125		300	2.625	2.125

**Table 54. Discharge (hot gas) line sizing RTUD 100 ton**

Ckt 1 Line	Leaving Water Temperature		Ckt 2 Line	Leaving Water Temperature			
	38-65 °F	10-37 °F		38-65 °F	10-37 °F		
Total Equiv. Length (ft)	25	2.125	2.125	Total Equiv. Length (ft)	25	2.125	2.125
	50	2.125	2.125		50	2.125	2.125
	75	2.125	2.125		75	2.125	2.125
	100	2.125	2.125		100	2.125	2.125
	125	2.125	2.125		125	2.125	2.125
	150	2.125	2.125		150	2.625	2.125
	175	2.125	2.125		175	2.625	2.125
	200	2.625	2.125		200	2.625	2.125
	225	2.625	2.125		225	2.625	2.625
	250	2.625	2.125		250	2.625	2.625
	275	2.625	2.125		275	2.625	2.625
	300	2.625	2.625		300	2.625	2.625



**Installation - Mechanical**

**Table 55. Discharge (hot gas) line sizing RTUD 110 ton**

Ckt 1 Line	Leaving Water Temperature		Ckt 2 Line	Leaving Water Temperature	
	38-65 °F	10-37 °F		38-65 °F	10-37 °F
25	2.125	2.125	25	2.125	2.125
50	2.125	2.125	50	2.125	2.125
75	2.125	2.125	75	2.125	2.125
100	2.125	2.125	100	2.125	2.125
125	2.125	2.125	125	2.125	2.125
150	2.625	2.125	150	2.625	2.125
175	2.625	2.125	175	2.625	2.125
200	2.625	2.625	200	2.625	2.125
225	2.625	2.625	225	2.625	2.625
250	2.625	2.625	250	2.625	2.625
275	2.625	2.625	275	2.625	2.625
300	2.625	2.625	300	2.625	2.625

**Table 57. Discharge (hot gas) line sizing RTUD 130 ton**

Ckt 1 Line	Leaving Water Temperature		Ckt 2 Line	Leaving Water Temperature	
	38-65 °F	10-37 °F		38-65 °F	10-37 °F
25	2.625	2.625	25	2.625	2.125
50	2.625	2.625	50	2.625	2.125
75	2.625	2.625	75	2.625	2.125
100	2.625	2.625	100	2.625	2.125
125	2.625	2.625	125	2.625	2.125
150	2.625	2.625	150	2.625	2.125
175	2.625	2.625	175	2.625	2.625
200	2.625	2.625	200	2.625	2.625
225	2.625	2.625	225	2.625	2.625
250	2.625	2.625	250	2.625	2.625
275	2.625	2.625	275	2.625	2.625
300	2.625	2.625	300	2.625	2.625

**Table 56. Discharge (hot gas) line sizing RTUD 120 ton**

Ckt 1 Line	Leaving Water Temperature		Ckt 2 Line	Leaving Water Temperature	
	38-65 °F	10-37 °F		38-65 °F	10-37 °F
25	2.625	2.125	25	2.625	2.125
50	2.625	2.125	50	2.625	2.125
75	2.625	2.125	75	2.625	2.125
100	2.625	2.125	100	2.625	2.125
125	2.625	2.125	125	2.625	2.125
150	2.625	2.125	150	2.625	2.125
175	2.625	2.125	175	2.625	2.625
200	2.625	2.625	200	2.625	2.625
225	2.625	2.625	225	2.625	2.625
250	2.625	2.625	250	2.625	2.625
275	2.625	2.625	275	2.625	2.625
300	2.625	2.625	300	2.625	2.625

**Table 58. Discharge (hot gas) line sizing RTUD 150 ton**

Ckt 1 Line	Leaving Water Temperature		Ckt 2 Line	Leaving Water Temperature	
	38-65 °F	10-37 °F		38-65 °F	10-37 °F
25	2.625	2.125	25	2.625	2.625
50	2.625	2.125	50	2.625	2.625
75	2.625	2.125	75	2.625	2.625
100	2.625	2.125	100	2.625	2.625
125	2.625	2.125	125	2.625	2.625
150	2.625	2.125	150	2.625	2.625
175	2.625	2.625	175	2.625	2.625
200	2.625	2.625	200	2.625	2.625
225	2.625	2.625	225	2.625	2.625
250	2.625	2.625	250	3.125	2.625
275	2.625	2.625	275	3.125	2.625
300	2.625	2.625	300	3.125	2.625

## Installation - Mechanical

**Table 59. Discharge (hot gas) line sizing RTUD 160 ton**

Ckt 1 Line	Leaving Water Temperature		Ckt 2 Line	Leaving Water Temperature		
	38-65 °F	10-37 °F		38-65 °F	10-37 °F	
Total Equiv. Length (ft)	25	2.625	2.625	25	2.625	2.625
	50	2.625	2.625	50	2.625	2.625
	75	2.625	2.625	75	2.625	2.625
	100	2.625	2.625	100	2.625	2.625
	125	2.625	2.625	125	2.625	2.625
	150	2.625	2.625	150	2.625	2.625
	175	2.625	2.625	175	2.625	2.625
	200	2.625	2.625	200	2.625	2.625
	225	2.625	2.625	225	2.625	2.625
	250	3.125	2.625	250	3.125	2.625
	275	3.125	2.625	275	3.125	2.625
	300	3.125	2.625	300	3.125	2.625

**Table 61. Discharge (hot gas) line sizing RTUD 200 ton**

Ckt 1 Line	Leaving Water Temperature		Ckt 2 Line	Leaving Water Temperature		
	38-65 °F	10-37 °F		38-65 °F	10-37 °F	
Total Equiv. Length (ft)	25	2.625	2.625	25	2.625	2.625
	50	2.625	2.625	50	2.625	2.625
	75	2.625	2.625	75	2.625	2.625
	100	2.625	2.625	100	2.625	2.625
	125	2.625	2.625	125	2.625	2.625
	150	2.625	2.625	150	2.625	2.625
	175	3.125	2.625	175	3.125	2.625
	200	3.125	2.625	200	3.125	2.625
	225	3.125	2.625	225	3.125	2.625
	250	3.125	3.125	250	3.125	2.625
	275	3.125	3.125	275	3.125	3.125
	300	3.125	3.125	300	3.125	3.125

**Table 60. Discharge (hot gas) line sizing RTUD 180 ton**

Ckt 1 Line	Leaving Water Temperature		Ckt 2 Line	Leaving Water Temperature		
	38-65 °F	10-37 °F		38-65 °F	10-37 °F	
Total Equiv. Length (ft)	25	2.625	2.625	25	2.625	2.625
	50	2.625	2.625	50	2.625	2.625
	75	2.625	2.625	75	2.625	2.625
	100	2.625	2.625	100	2.625	2.625
	125	2.625	2.625	125	2.625	2.625
	150	2.625	2.625	150	2.625	2.625
	175	2.625	2.625	175	3.125	2.625
	200	2.625	2.625	200	3.125	2.625
	225	2.625	2.625	225	3.125	2.625
	250	3.125	2.625	250	3.125	2.625
	275	3.125	2.625	275	3.125	3.125
	300	3.125	2.625	300	3.125	3.125

**Table 62. Discharge (hot gas) line sizing RTUD 220 ton**

Ckt 1 Line	Leaving Water Temperature		Ckt 2 Line	Leaving Water Temperature		
	38-65 °F	10-37 °F		38-65 °F	10-37 °F	
Total Equiv. Length (ft)	25	2.625	2.625	25	3.125	3.125
	50	2.625	2.625	50	3.125	3.125
	75	2.625	2.625	75	3.125	3.125
	100	2.625	2.625	100	3.125	3.125
	125	2.625	2.625	125	3.125	3.125
	150	2.625	2.625	150	3.125	3.125
	175	3.125	2.625	175	3.125	3.125
	200	3.125	2.625	200	3.125	3.125
	225	3.125	2.625	225	3.125	3.125
	250	3.125	3.125	250	3.125	3.125
	275	3.125	3.125	275	3.125	3.125
	300	3.125	3.125	300	3.625	3.125

Table 63. Discharge (hot gas) line sizing RTUD 250 ton

Ckt 1 Line	Leaving Water Temperature		Ckt 2 Line	Leaving Water Temperature	
	38-65 °F	10-37 °F		38-65 °F	10-37 °F
25	3.125	3.125	25	3.125	3.125
50	3.125	3.125	50	3.125	3.125
75	3.125	3.125	75	3.125	3.125
100	3.125	3.125	100	3.125	3.125
125	3.125	3.125	125	3.125	3.125
150	3.125	3.125	150	3.125	3.125
175	3.125	3.125	175	3.125	3.125
200	3.125	3.125	200	3.125	3.125
225	3.125	3.125	225	3.125	3.125
250	3.125	3.125	250	3.125	3.125
275	3.125	3.125	275	3.125	3.125
300	3.625	3.125	300	3.625	3.125

Example

Figure 40. Example configuration

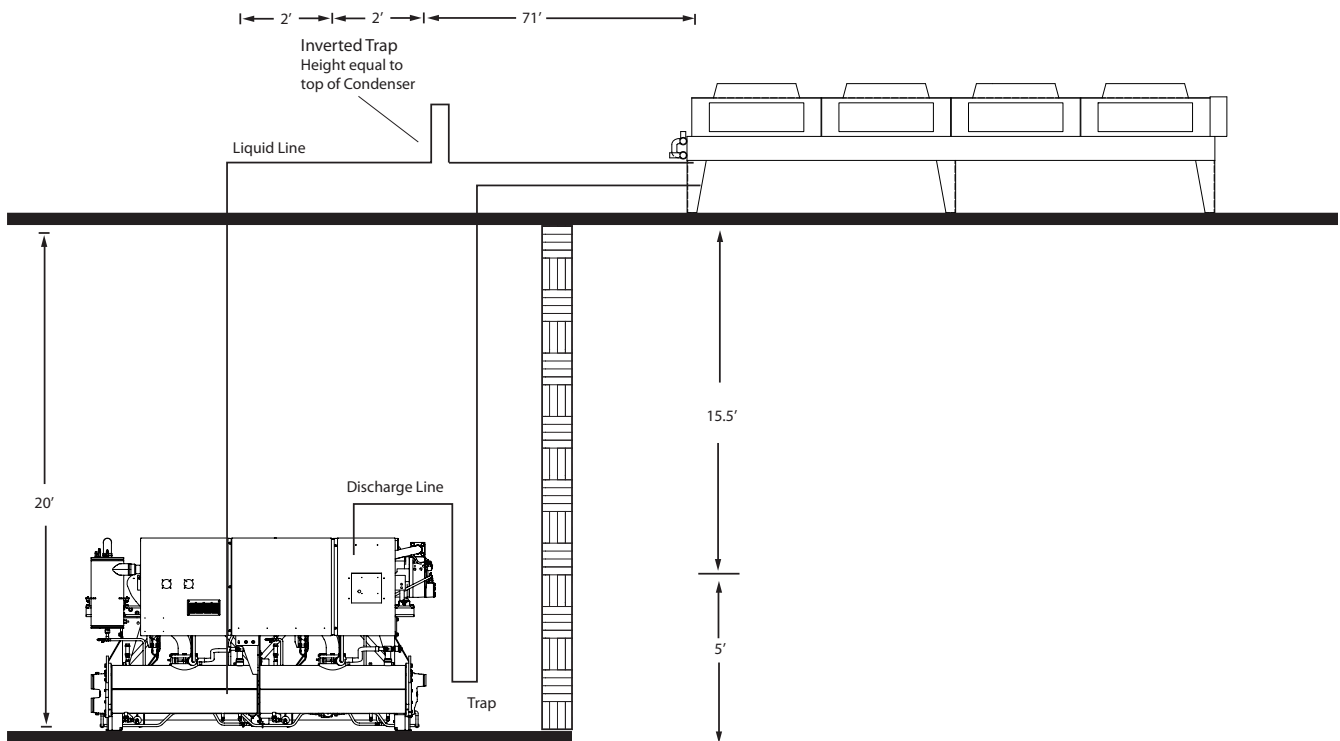

## Installation - Mechanical

Shown in [Figure 40, p. 70](#) are RTUD 100 ton and Trane Levitor II condenser designed for a leaving evaporator water temperature of 42°F. This example will show how to calculate the line sizes for both the liquid and discharge lines. The discharge line consists of one long radius elbow and 4 short radius elbows. The liquid line also consists of one long radius elbow and 4 short radius elbows.

### Discharge Line

Actual length of lines = 2 + 5 + 71 + 15.5 + 5 = 98.5 ft.

Total equivalent length = 1.5 x 98.5 = 147.75 ft.

Approximate line size for discharge lines

[Table 54, p. 67](#) = 2 1/8"

Equivalent length of one long radius elbow at 2 1/8"

[Table 39](#) = 3.4 ft.

Equivalent length of 4 short radius elbows at 2 1/8"

[Table 39](#) = 4 x 5.2 ft. = 20.8 ft.

Total equivalent length = 98.5 + 3.4 + 20.8 = 122.7 ft.

New line size for discharge lines remains

[Table 54](#)

Ckt 1 = 2 1/8"

Ckt 2 = 2 1/8"

ALL DISCHARGE LINE SIZES ARE = 2 1/8"

### Liquid Lines

Actual length of liquid lines = 8 + 75 + 20 + 8 = 111 ft.

Total equivalent length = 1.5 X 111 = 166.5 ft.

Approximate liquid line size

[Table 42, p. 63](#) = 1 1/8"

Equiv. length of one long radius elbow at 1 1/8"

[Table 39](#) = 1.9

Equiv. length of 4 short radius elbows at 1 1/8"

[Table 39](#) = 4 x 2.7 ft. = 10.8 ft.

Total equivalent length = 111 + 1.9 + 10.8 = 123.7 ft.

[Table 42](#)

Ckt 1 = 1 1/8"

Ckt 2 = 1 1/8"

ALL LIQUID LINE SIZES ARE = 1 1/8"

### Refrigerant Charge Determination

The approximate amount of the refrigerant charge required by the system must be determined by referring to [Table 64](#) and must be verified by running the system and checking the liquid line sightglasses.

**Table 64. System refrigerant charge - lbs**

Ton	Condenser		RTUD		Max. Unit Charge	
	Ckt 1	Ckt 2	Ckt 1	Ckt 2	Ckt 1	Ckt 2
80	40	40	50	50	318	318
90	52	52	49	49	308	308
100	68	68	47	47	308	308
110	68	68	65	65	359	359
120	85	85	64	64	352	352
130	85	85	64	64	352	352
150	76	76	62	62	347	347
160	76	76	66	66	396	396
180	76	101	66	66	396	396
200	101	101	66	66	391	391
220	101	134	63	63	382	382
250	134	134	61	61	373	373

Note: The maximum charge can reduce the maximum length of the piping. Due to maximum allowable refrigerant charge not all units can have 200 feet of piping.

To determine the approximate charge, first refer to [Table 64](#) and establish the required charge without the field-installed piping. Then refer to [Table 65](#), to determine the charge required for the field-installed piping. The approximate charge is therefore the sum of the values from [Table 64](#) and [Table 65](#).

**Table 65. Field-installed piping charge**

Pipe O.D.	Discharge Line	
	(lbs)	Liquid Line (lbs)
1 1/8	-	41
1 3/8	-	62
1 5/8	-	88
2 1/8	8	154
2 5/8	13	-
3 1/8	18	-
4 1/8	32	-

Note: The amounts of refrigerant listed in [Table 65](#) are based on 100 feet of pipe. Actual requirements will be in direct proportion to the actual length of the piping.

Note: [Table 65](#) assumes: Liquid Temperature = 105°F; Saturated Discharge Temperature = 125°F; Discharge Superheat = 30°F.

**NOTICE:****Equipment Damage!**

Add initial field refrigerant charge only through the service valve on the liquid line, not the service valves on the evaporator, and insure that water is flowing through the evaporator during the charging process. Failure to do the above could result in equipment damage.

**RTUD Chilled Water Flow Control****NOTICE:****Equipment Damage!**

ALL RTUD unit chilled water pumps **MUST** be controlled by the Trane CH530 to avoid catastrophic damage to the evaporator due to freezing

**Oil Charge Determination**

The RTUD unit is factory charged with the amount of oil required by the system. No additional oil is required for field installed piping.

**Outdoor Air Temperature Sensor Installation Requirements**

The outdoor air temperature sensor is optional for the RTWD water cooled units, but is a required sensor for the RTUD compressor chiller units. The sensor is required as an important input to the condenser fan control algorithm as well as for the low outdoor air ambient lockout feature. The temperature sensor probe is shipped separately inside the control panel.

It is necessary for the chiller installer to locate and install the separate outdoor air sensor probe at the remote air cooled condenser at a location to sense the coil's entering air temperature, while avoiding direct sunlight. It should be located at least 2" from the coil face and somewhere "in-between" the two refrigerant circuits. Where the condenser installation is such that the two refrigerant circuit's condensers are physically separate from each other, or one circuit is more likely to see re-circulated warmer air, an attempt should be made to locate the probe to see an average temperature of the two separate condensers.

**Important:** The probe provided must not be substituted with another probe, as the probe and the electronics are "matched / calibrated" at the factory for accuracy.

A twisted pair sheathed cable shall be run and connected between the probe at the remote condenser and its LLID module in the chiller control panel. The sensor's circuit is a class II power limited analog circuit and therefore the wire should not be run in close proximity to any power or line voltage wiring. The splices at the condenser end,

should be made to be water tight. The wire run should be physically supported at equal intervals with consideration for safety and reliability/durability with wire ties or similar to meet local codes.

**Fan Control for the Remote Air Cooled Condenser**

The CH530 Controls for the RTUD compressor chiller provide as an option, the flexible and full control of 2-circuit remote air cooled condenser fans. In addition to the option for controlling between 2 to 8 fixed speed fans per circuit (or multiples thereof), a separate additional option includes the ability to control either two speed fans or variable speed fan/drive combinations in conjunction with other fixed speed fans, to provide low ambient outdoor air temperature capability. The controls will also provide an option for a simple per circuit interlock output (in lieu of actual fan control) to use in the scenario in which independent fan head pressure or differential pressure controls (by others) is applied. See "[Fan Control By Others](#)" on Page 164 for more information. It is recommended however, that for the best overall unit performance, the integral fan control option is selected.

The controls support control of a remote, air cooled condenser fan deck, from 2 to 8 fans per circuit (1-8 fans for variable speed). It supports options to control the following types of standard ambient outdoor air temperature fan decks: 1) all fans fixed speed, and 2) all fans two speed. It will also support the following low ambient outdoor air temperature fan decks 1) one fan per circuit is Two-Speed, (remaining fans fixed speed), and 2) One fan per circuit is variable speed i.e. variable frequency drive (VFD), (remaining fans fixed speed). In the variable fan low ambient outdoor air option the VFD fan and fixed speed fans are sequenced accordingly to provide continuous control from 0-100% air flow per circuit. Fan staging provides the correct combination of fixed speed fan relay, VFD relay (to enable operation of the VFD), and speed outputs to provide air flow control commanded by the fan algorithm running inside the CH530 Main Processor. The fan deck arrangement is independently configurable per circuit.

Since the condenser is provided separately from the RTUD compressor chiller, the RTUD electrical panel design does not provide for condensing unit's control power requirements. The chiller's control power transformer is not sized to provide the control power for the additional fan contactor loads. The CH530 controls, when properly optioned, will provide for pilot duty rated relays, low voltage binary inputs, and low voltage analog outputs to control the remote contactors and inverters provided by others. The CH530 fan control relays located in the chiller control panel, are intended to control the fan contactors that are located in the remote air cooled condenser panel. The Fan Control Relays are rated for up to 7.2 Amps resistive, 2.88 Amps pilot duty 1/3 HP, 7.2 FLA at 120 VAC, and up to 5 Amps general purpose at 240 VAC. All wiring



## Installation - Mechanical

for the field connections to the condenser, will have screw terminals for termination in the RTUD control panel with the exception of the outdoor air temperature sensor (addressed above). Refer to the wiring diagrams.

Separate fan control algorithms are used for fixed speed and variable speed systems. For the variable speed fan deck option, the fan control reverts to fixed speed control if an inverter drive fault is detected through a binary input interface with the drive. An informational diagnostic is also provided to indicate the issue.

For more fan control information, see chapter sections beginning with "Fan Configurations" on Page 163.

### RTUD Condenser Elevation Setting

Condenser elevation setting is a require input during startup of an RTUD chiller, and is accessible in TechView, **Figure 41. RTUD Condenser elevation setting**

on the Unit View Screen. Go to the Unit View/Chiller Tab, select Condenser Elevation setting and enter condenser elevation in appropriate units. See **Figure 41**. The shipped default of this setting is 0 and it represents the distance of the bottom of the condenser, relative to the top of the evaporator. Use a positive value for the condenser above the evaporator and a negative value for the condenser below the evaporator. An estimate to within +/- 3 feet is required.

Condenser elevation setting allows proper EXV operation. Failure to properly set the elevation can result in low pressure cutout trips, or low differential pressure trips during startup or large load transients, as well as poor EXV liquid level control during operation.

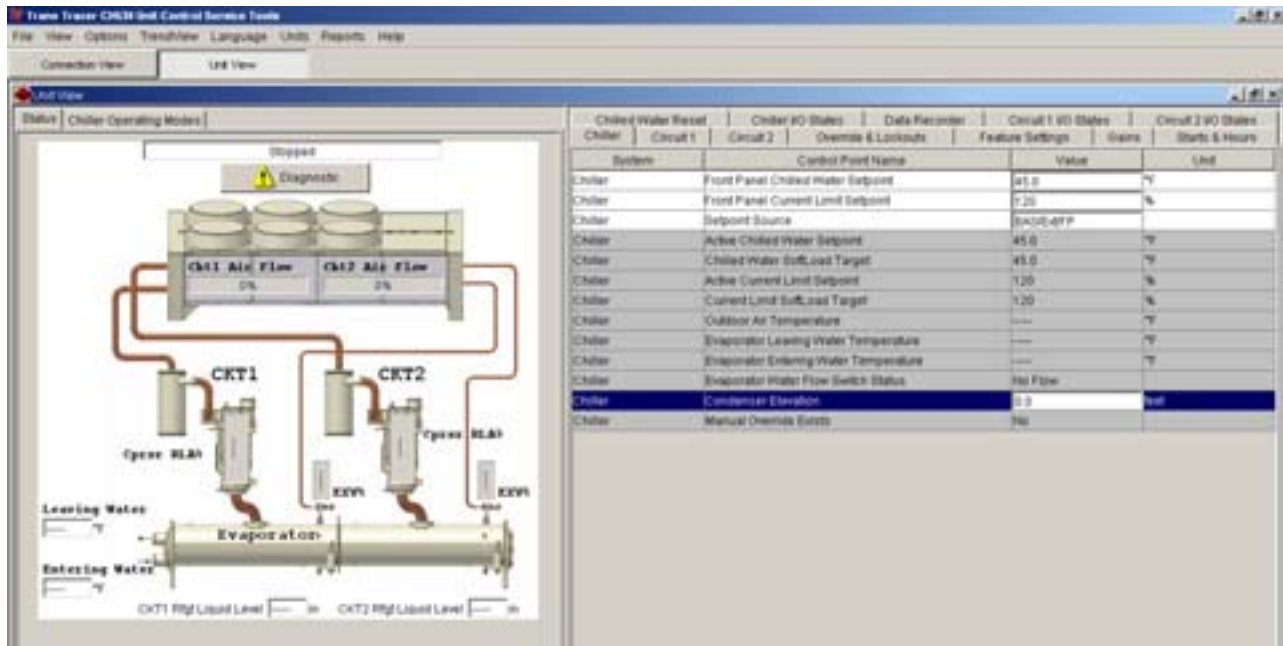

## Shipping Spacers

**NOTICE:**

**Excessive Noise and Vibration!**

Failure to remove the spacers could result in excessive noise and vibration transmission into the building

For RTWD units listed in table below, and all RTUD 80-130 ton units, remove and discard the two shipping spacers with four bolts, located underneath the oil separator, as shown in [Figure 42, p. 74](#) before starting unit.

**Table 66. RTWD Units that require oil sep spacer removal**

Size	Hz	Efficiency
80, 90, 100, 110, 120, 130, 140	60	STD
80, 90, 100, 110, 120, 130	60	HIGH
70, 80, 90, 100, 110, 120, 130, 140, 150	50	STD
60, 70, 80, 90, 100, 110, 120	50	HIGH

**Figure 42. Oil separator spacer removal - RTWD and RTUD 80-130T**

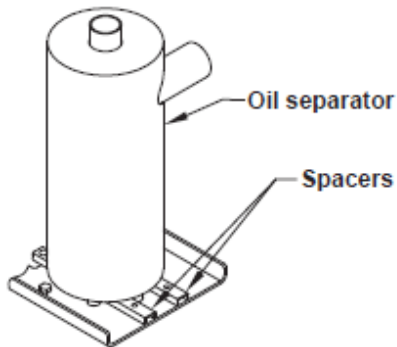

For RTUD 150-250 ton units, remove and discard the four sets of shipping spacers (each including two spacers and one bolt), located within the oil separator mounting brackets, as shown in [Figure , p. 74](#) before starting unit. Failure to remove the spacers could result in excessive noise and vibration transmission into the building

**Figure 43. Oil sep spacer removal - RTUD 150-250T**

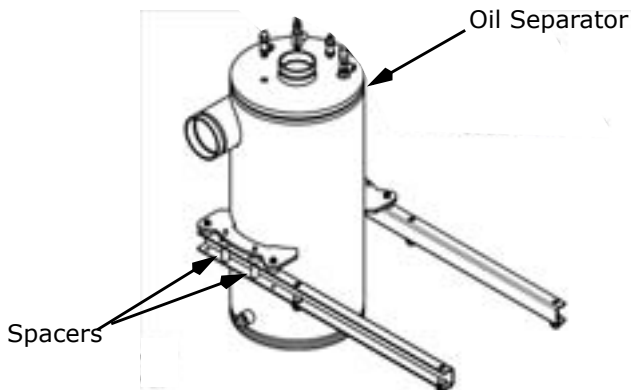

# Installation - Electrical

## General Recommendations

All wiring must comply with local codes and the National Electric Code. Typical field wiring diagrams are included at the end of the manual. Minimum circuit ampacities and other unit electrical data are on the unit nameplate and in [Table 67](#). See the unit order specifications for actual electrical data. Specific electrical schematics and connection diagrams are shipped with the unit.

<b>NOTICE: ⚠ WARNING</b>
<b>Hazardous Voltage!</b>
<b>Disconnect all electric power, including remote disconnects before servicing. Follow proper lockout/tagout procedures to ensure the power can not be inadvertently energized. Failure to disconnect power before servicing could result in death or serious injury.</b>

<b>NOTICE:</b>
<b>Use Copper Conductors Only!</b>
<b>Unit terminals are not designed to accept other types of conductors. Failure to use copper conductors could result in equipment damage.</b>

**Important:** Do not allow conduit to interfere with other components, structural members or equipment. Control voltage (115V) wiring in conduit must be separate from conduit carrying low voltage (<30V) wiring. To prevent control malfunctions, do not run low voltage wiring (<30V) in conduit with conductors carrying more than 30 volts.

**Table 67. Electrical Data - RTWD - 60 Hz - standard efficiency - standard condensing temperature**

Unit Size	Rated Voltage	Unit Wiring				Motor Data		
		Single Point Power - 1 Power Connection		Dual Point Power - 2 Power Connections		RLA	LRA YD	LRA XL
		MCA	MOP	MCA	MOP			
80	200/60/3	216	300	122/118	200/200	94/94	276/276	912/912
	230/60/3	188	250	106/103	175/175	82/82	238/238	786/786
	380/60/3	115	150	65/63	110/110	50/50	138/138	456/456
	460/60/3	94	125	53/51	90/90	41/41	114/114	376/376
	575/60/3	76	100	43/41	70/70	33/33	93/93	308/308
90	200/60/3	249	350	140/136	225/225	109/109	304/304	1003/1003
	230/60/3	217	300	122/119	200/200	95/95	262/262	866/866
	380/60/3	130	175	73/71	125/125	57/57	161/161	530/530
	460/60/3	110	150	62/60	100/100	48/48	131/131	433/433
	575/60/3	87	110	49/48	80/80	38/38	105/105	346/346
100	200/60/3	291	400	140/178	225/300	109/142	304/355	1003/1137
	230/60/3	252	350	122/154	200/250	95/123	262/294	866/942
	380/60/3	153	225	73/94	125/150	57/75	161/177	530/566
	460/60/3	127	175	62/78	100/125	48/62	131/147	433/471
	575/60/3	102	150	49/63	80/110	38/50	105/118	346/377
110	200/60/3	324	450	182/178	300/300	142/142	355/355	1137/1137
	230/60/3	280	400	157/154	250/250	123/123	294/294	942/942
	380/60/3	171	225	96/94	150/150	75/75	177/177	566/566
	460/60/3	141	200	80/78	125/125	62/62	147/147	471/471
	575/60/3	114	150	64/63	110/110	50/50	118/118	377/377
120	200/60/3	356	500	182/210	300/350	142/168	355/419	1137/1368
	230/60/3	309	450	157/183	250/300	123/146	294/367	942/1200
	380/60/3	187	250	96/110	150/175	75/88	177/229	566/747
	460/60/3	155	225	79/91	125/150	62/73	147/184	471/600
	575/60/3	125	175	64/74	110/125	50/59	118/148	377/483



## Installation - Electrical

**Table 67. Electrical Data - RTWD - 60 Hz - standard efficiency - standard condensing temperature (continued)**

Unit Size	Rated Voltage	Unit Wiring				Motor Data		
		Single Point Power - 1 Power Connection		Dual Point Power - 2 Power Connections		RLA	LRA YD	LRA XL
		MCA	MOP	MCA	MOP			
130	200/60/3	382	500	214/210	350/350	168/168	419/419	1368/1368
	230/60/3	332	450	186/183	300/300	146/146	367/367	1200/1200
	380/60/3	200	250	112/110	200/175	88/88	229/229	747/747
	460/60/3	166	225	93/91	150/150	73/73	184/184	600/600
	575/60/3	134	175	75/74	125/125	59/59	148/148	483/483
140	200/60/3	425	600	214/253	350/450	168/202	419/487	1368/1498
	230/60/3	368	500	186/219	300/350	146/175	367/427	1200/1314
	380/60/3	223	300	112/133	200/225	88/106	229/260	747/801
	460/60/3	185	250	93/110	150/175	73/88	184/212	600/652
	575/60/3	148	200	75/88	125/150	59/70	148/172	483/528

**Notes:**

1. Voltage Utilization Range: +/- 10% of rated voltage  
Rated voltage (use range): 208/60/3 (187.2-228.8), 230/60/3(208-254), 380/60/3 (342-418), 460/60/3 (414-506), 575/60/3 (516-633)
2. MCA-minimum circuit ampacity
3. MOP-maximum overcurrent protection
4. RLA-rated load amps are rated in accordance with UL Standard 1995.
5. LRA-locked rotor amps are based on full winding starts.
6. LRA YD-Locked Rotor Amps in Wye configuration. LRA XL-Locked Rotor Amps in the Delta configuration.
7. Local codes may take precedence.
8. Data containing information on two circuits shown as follows: circuit 1/circuit 2.
9. Standard condensing temperature option refers to entering condenser water temperatures 95°F (35°C) and below.

**Table 68. Electrical Data - RTWD - 60 Hz - high efficiency - standard condensing temperature**

Unit Size	Rated Voltage	Unit Wiring				Motor Data		
		Single Point Power - 1 Power Connection		Dual Point Power - 2 Power Connections		RLA	LRA YD	LRA XL
		MCA	MOP	MCA	MOP			
80	200/60/3	211	300	119/115	200/200	92/92	276/276	912/912
	230/60/3	184	250	104/100	175/175	80/80	238/238	786/786
	380/60/3	112	150	63/61	110/110	49/49	138/138	456/456
	460/60/3	92	125	52/50	90/90	40/40	114/114	376/376
	575/60/3	73	100	32/32	93/93	32/32	93/93	308/308
90	200/60/3	245	350	138/134	225/225	107/107	304/304	1003/1003
	230/60/3	213	300	120/116	200/200	93/93	262/262	866/866
	380/60/3	128	175	72/70	125/125	56/56	161/161	530/530
	460/60/3	108	150	61/59	100/100	47/47	131/131	433/433
	575/60/3	85	110	48/46	80/80	37/37	105/105	346/346
100	200/60/3	284	400	138/173	225/300	107/138	304/355	1003/1137
	230/60/3	247	350	120/150	200/250	93/120	262/294	866/942
	380/60/3	149	200	72/91	125/150	56/73	161/177	530/566
	460/60/3	124	175	61/75	100/125	47/60	131/147	433/471
	575/60/3	98	125	48/60	80/100	37/48	105/118	346/377
110	200/60/3	315	450	177/173	300/300	138/138	355/355	1137/1137
	230/60/3	274	350	154/150	250/250	120/120	294/294	942/942
	380/60/3	166	225	93/91	150/150	73/73	177/177	566/566
	460/60/3	137	175	77/75	125/125	60/60	147/147	471/471
	575/60/3	109	150	61/60	100/100	48/48	118/118	377/377

## Installation - Electrical

**Table 68. Electrical Data - RTWD - 60 Hz - high efficiency - standard condensing temperature (continued)**

Unit Size	Rated Voltage	Unit Wiring				Motor Data		
		Single Point Power - 1 Power Connection		Dual Point Power - 2 Power Connections		RLA	LRA YD	LRA XL
		MCA	MOP	MCA	MOP			
120	200/60/3	347	500	177/205	300/350	138/164	355/419	1137/1368
	230/60/3	302	400	154/179	250/300	120/143	294/367	942/1200
	380/60/3	184	250	93/109	150/175	73/87	177/229	566/747
	460/60/3	152	200	77/90	125/150	60/72	147/184	471/600
	575/60/3	121	175	61/71	100/125	48/57	118/148	377/483
130	200/60/3	373	500	209/205	350/350	164/164	419/419	1368/1368
	230/60/3	325	450	182/179	300/300	143/143	367/367	1200/1200
	380/60/3	198	250	111/109	175/175	87/87	229/229	747/747
	460/60/3	164	225	92/90	150/150	72/72	184/184	600/600
	575/60/3	130	175	73/71	125/125	57/57	148/148	483/483
150	200/60/3	414	600	210/245	350/400	164/196	419/487	1368/1498
	230/60/3	361	500	183/214	300/350	143/171	367/427	1200/1314
	380/60/3	218	300	111/129	175/225	87/103	229/260	747/801
	460/60/3	182	250	92/108	150/175	72/86	184/212	600/652
	575/60/3	145	200	73/87	125/150	57/69	148/172	483/528
160	200/60/3	446	600	250/245	400/400	196/196	487/487	1498/1498
	230/60/3	389	500	218/214	350/350	171/171	427/427	1314/1314
	380/60/3	234	300	131/129	225/225	103/103	260/260	801/801
	460/60/3	196	250	110/108	175/175	86/86	212/212	652/652
	575/60/3	157	225	88/87	150/150	69/69	172/172	528/528
180	200/60/3	484	700	250/284	400/500	196/227	487/600	1498/1845
	230/60/3	421	600	218/247	350/400	171/197	427/506	1314/1556
	380/60/3	256	350	131/150	225/250	103/120	260/316	801/973
	460/60/3	213	300	110/125	175/225	86/100	212/252	652/774
	575/60/3	171	250	88/100	150/175	69/80	172/205	528/631
200	200/60/3	515	700	288/284	500/500	227/227	600/600	1845/1845
	230/60/3	447	600	250/247	400/400	197/197	506/506	1556/1556
	380/60/3	273	350	153/150	250/250	120/120	316/316	973/973
	460/60/3	227	300	127/125	225/225	100/100	252/252	774/774
	575/60/3	182	250	102/100	175/175	80/80	205/205	631/631
220	200/60/3	583	800	288/352	500/600	227/281	600/701	1845/2156
	230/60/3	509	700	250/308	400/500	197/246	506/571	1556/1756
	380/60/3	309	450	153/187	250/300	120/149	316/345	973/1060
	460/60/3	256	350	127/154	225/250	100/123	252/285	774/878
	575/60/3	204	300	102/123	175/200	80/98	205/229	631/705
250	200/60/3	637	800	356/352	600/600	281/281	701/701	2156/2156
	230/60/3	558	800	312/308	500/500	246/246	571/571	1756/1756
	380/60/3	338	450	189/187	300/300	149/149	345/345	1060/1060
	460/60/3	279	700	156/154	250/250	123/123	285/285	878/878
	575/60/3	222	300	124/123	200/200	98/98	229/229	705/705

**Notes:**

1. Voltage Utilization Range: +/- 10% of rated voltage  
Rated voltage (use range): 208/60/3 (187.2-228.8), 230/60/3(208-254), 380/60/3 (342-418), 460/60/3 (414-506), 575/60/3 (516-633)
2. MCA—minimum circuit ampacity
3. MOP—maximum overcurrent protection
4. RLA—rated load amps are rated in accordance with UL Standard 1995.
5. LRA—locked rotor amps are based on full winding starts.
6. LRA YD—Locked Rotor Amps in Wye configuration. LRA XL—Locked Rotor Amps in the Delta configuration.
7. Local codes may take precedence.
8. Data containing information on two circuits shown as follows: circuit 1/circuit 2.
9. Standard condensing temperature option refers to entering condenser water temperatures 95°F/35°C) and below.



## Installation - Electrical

**Table 69. Electrical Data - RTWD - 60 Hz - premium efficiency - standard condensing temperature**

Unit Size	Rated Voltage	Unit Wiring				Motor Data		
		Single Point Power - 1 Power Connection		Dual Point Power - 2 Power Connections		RLA	LRA YD	LRA XL
		MCA	MOP	MCA	MOP			
150	200/60/3	410	600	208/243	350/400	163/194	419/487	1368/1498
	230/60/3	360	500	183/213	300/350	143/170	367/427	1200/1314
	380/60/3	277	300	110/129	175/225	86/103	229/260	747/801
	460/60/3	180	250	91/107	150/175	71/85	184/212	600/652
	575/60/3	145	200	74/85	125/150	58/68	148/172	483/528
160	200/60/3	441	600	247/243	400/400	194/194	487/487	1498/1498
	230/60/3	387	500	217/213	350/350	170/170	427/427	1314/1314
	380/60/3	234	300	131/129	225/225	103/103	260/260	801/801
	460/60/3	194	250	109/107	175/175	85/85	212/212	652/652
	575/60/3	155	200	87/85	150/150	68/68	172/172	528/528
180	200/60/3	481	700	247/283	400/500	194/226	487/600	1498/1845
	230/60/3	420	600	217/247	350/400	170/197	427/506	1314/1556
	380/60/3	256	350	131/150	225/250	103/120	260/316	801/973
	460/60/3	212	300	109/125	175/225	85/100	212/252	652/774
	575/60/3	171	250	87/102	150/175	68/81	172/205	528/631
200	200/60/3	513	700	287/283	500/500	226/226	600/600	1845/1845
	230/60/3	447	600	250/247	400/400	197/197	506/506	1556/1556
	380/60/3	275	350	153/150	250/250	120/120	316/316	973/973
	460/60/3	277	300	127/125	225/225	100/100	252/252	774/774
	575/60/3	184	250	103/102	175/175	81/81	205/205	631/631

**Notes:**

1. Voltage Utilization Range: +/- 10% of rated voltage  
Rated voltage (use range): 208/60/3 (187.2-228.8), 230/60/3(208-254), 380/60/3 (342-418), 460/60/3 (414-506), 575/60/3 (516-633)
2. MCA—minimum circuit ampacity
3. MOP—maximum overcurrent protection
4. RLA—rated load amps are rated in accordance with UL Standard 1995.
5. LRA—locked rotor amps are based on full winding starts.
6. LRA YD—Locked Rotor Amps in Wye configuration. LRA XL—Locked Rotor Amps in the Delta configuration.
7. Local codes may take precedence.
8. Data containing information on two circuits shown as follows: circuit 1/circuit 2.
9. Standard condensing temperature option refers to entering condenser water temperatures 95°F (35°C) and below.

**Table 70. Electrical Data - RTWD - 60 Hz - high efficiency - high condensing temperature**

Unit Size	Rated Voltage	Unit Wiring				Motor Data		
		Single Point Power - 1 Power Connection		Dual Point Power - 2 Power Connections		RLA	LRA YD	LRA XL
		MCA	MOP	MCA	MOP			
80	200/60/3	263	350	148/144	250/250	115/115	276/276	912/912
	230/60/3	229	300	129/125	225/225	100/100	238/238	786/786
	380/60/3	139	200	78/76	125/125	61/61	138/138	456/456
	460/60/3	114	150	64/63	110/110	50/50	114/114	376/376
	575/60/3	91	125	51/50	90/90	40/40	93/93	308/308
90	200/60/3	319	450	179/175	300/300	140/140	304/304	1003/1003
	230/60/3	278	400	156/153	250/250	122/122	262/262	866/866
	380/60/3	169	225	95/92	150/150	74/74	161/161	530/530
	460/60/3	139	200	78/76	125/125	61/61	131/131	433/433
	575/60/3	112	150	63/61	110/110	49/49	105/105	346/346

## Installation - Electrical

**Table 70. Electrical Data - RTWD - 60 Hz - high efficiency - high condensing temperature (continued)**

Unit Size	Rated Voltage	Unit Wiring				Motor Data		
		Single Point Power - 1 Power Connection		Dual Point Power - 2 Power Connections		RLA	LRA YD	LRA XL
		MCA	MOP	MCA	MOP			
100	200/60/3	364	500	179/220	300/350	140/176	304/355	1003/1137
	230/60/3	317	450	156/191	250/300	122/153	262/294	866/942
	380/60/3	192	250	95/116	150/200	74/93	161/177	530/566
	460/60/3	159	225	78/96	125/150	61/77	131/147	433/471
	575/60/3	127	175	63/76	110/125	49/61	105/118	346/377
110	200/60/3	400	500	224/220	400/350	176/176	355/355	1137/1137
	230/60/3	348	500	195/191	300/300	153/153	294/294	942/942
	380/60/3	211	300	118/116	200/200	93/93	177/177	566/566
	460/60/3	175	250	98/96	175/150	77/77	147/147	471/471
	575/60/3	139	175	78/76	125/125	61/61	118/118	377/377
120	200/60/3	436	600	224/256	400/450	176/205	355/419	1137/1368
	230/60/3	380	500	195/224	300/400	153/179	294/367	942/1200
	380/60/3	230	300	118/135	200/225	93/108	177/229	566/747
	460/60/3	191	250	98/113	175/200	77/90	147/184	471/600
	575/60/3	152	200	78/90	125/150	61/72	118/148	377/483
130	200/60/3	N/A	N/A	260/256	450/450	205/205	419/419	1368/1368
	230/60/3	406	500	227/224	400/400	179/179	367/367	1200/1200
	380/60/3	245	350	137/135	225/225	108/108	229/229	747/747
	460/60/3	204	250	114/113	200/200	90/90	184/184	600/600
	575/60/3	163	225	91/90	150/150	72/72	148/148	483/483
150	200/60/3	502	700	261/293	450/500	205/234	419/487	1368/1498
	230/60/3	438	600	228/255	400/450	179/204	367/427	1200/1314
	380/60/3	267	350	138/157	225/250	108/125	229/260	747/801
	460/60/3	220	300	115/128	200/225	90/102	184/212	600/652
	575/60/3	179	250	92/105	150/175	72/84	148/172	483/528
160	200/60/3	531	700	297/293	500/500	234/234	487/487	1498/1498
	230/60/3	463	600	259/255	450/450	204/204	427/427	1314/1314
	380/60/3	284	400	159/157	250/250	125/125	260/260	801/801
	460/60/3	232	300	130/128	225/225	102/102	212/212	652/652
	575/60/3	191	250	107/105	175/175	84/84	172/172	528/528
180	200/60/3	591	800	297/353	500/600	234/282	487/600	1498/1845
	230/60/3	512	700	259/304	450/500	204/243	427/506	1314/1556
	380/60/3	309	450	159/182	250/300	125/145	260/316	801/973
	460/60/3	253	350	130/149	225/250	102/119	212/252	652/774
	575/60/3	207	300	107/122	175/200	84/97	172/205	528/631
200	200/60/3	621	800	347/343	600/600	274/274	600/600	1845/1845
	230/60/3	551	700	308/304	500/500	243/243	506/506	1556/1556
	380/60/3	327	450	183/180	300/300	144/144	316/316	973/973
	460/60/3	270	350	151/149	250/250	119/119	252/252	774/774
	575/60/3	220	300	123/122	200/200	97/97	205/205	631/631
220	200/60/3	702	1000	357/415	600/700	282/332	600/701	1845/2156
	230/60/3	608	800	308/362	500/600	243/289	506/571	1556/1756
	380/60/3	373	500	184/225	300/400	145/180	316/345	973/1060
	460/60/3	303	400	151/182	250/300	119/145	252/285	774/878
	575/60/3	244	350	123/145	200/250	97/116	205/229	631/705



## Installation - Electrical

**Table 70. Electrical Data - RTWD - 60 Hz - high efficiency - high condensing temperature (continued)**

Unit Size	Rated Voltage	Unit Wiring				Motor Data		
		Single Point Power - 1 Power Connection		Dual Point Power - 2 Power Connections		RLA	LRA YD	LRA XL
		MCA	MOP	MCA	MOP			
250	200/60/3	752	1000	420/415	700/700	332/332	701/701	2156/2156
	230/60/3	654	800	365/362	600/600	289/289	571/571	1756/1756
	380/60/3	408	500	228/225	400/400	180/180	345/345	1060/1060
	460/60/3	329	450	184/182	300/300	145/145	285/285	878/878
	575/60/3	263	350	147/145	250/250	116/116	229/229	705/705

**Notes:**

1. Voltage Utilization Range: +/- 10% of rated voltage  
Rated voltage (use range): 208/60/3 (187.2-228.8), 230/60/3(208-254), 380/60/3 (342-418), 460/60/3 (414-506), 575/60/3 (516-633)MCA–minimum circuit ampacity
2. MOP–maximum overcurrent protection
3. RLA–rated load amps are rated in accordance with UL Standard 1995.
4. LRA–locked rotor amps are based on full winding starts.
5. LRA YD–Locked Rotor Amps in Wye configuration. LRA XL–Locked Rotor Amps in the Delta configuration.
6. Local codes may take precedence.
7. Data containing information on two circuits shown as follows: circuit 1/circuit 2.
8. High condensing temperature option refers to entering condenser water temperatures above 95°F (35°C).

**Table 71. Electrical Data - RTWD - 60 Hz - premium efficiency - high condensing temperature**

Unit Size	Rated Voltage	Unit Wiring				Motor Data		
		Single Point Power - 1 Power Connection		Dual Point Power - 2 Power Connections		RLA	LRA YD	LRA XL
		MCA	MOP	MCA	MOP			
150	200/60/3	498	700	252/295	400/500	198/236	419/487	1368/1498
	230/60/3	430	600	219/254	350/450	172/203	367/427	1200/1314
	380/60/3	266	350	138/155	225/250	108/124	229/260	747/801
	460/60/3	218	300	112/128	175/225	88/102	184/212	600/652
	575/60/3	178	250	91/105	150/175	71/84	148/172	483/528
160	200/60/3	536	700	300/295	500/500	236/236	487/487	1498
	230/60/3	461	600	258/254	450/450	203/203	427/427	1314/1314
	380/60/3	282	400	158/155	250/250	124/124	260/260	801/801
	460/60/3	232	300	130/128	225/225	102/102	212/212	652/652
	575/60/3	191	250	107/105	175/175	84/84	172/172	528/528
180	200/60/3	583	800	300/343	500/600	236/274	487/600	1498/1845
	230/60/3	511	700	258/304	450/500	203/243	427/506	1314/1556
	380/60/3	307	450	158/180	250/300	124/144	260/316	801/973
	460/60/3	253	350	130/149	225/250	102/119	212/252	652/774
	575/60/3	207	300	107/122	175/200	84/97	172/205	528/631
200	200/60/3	621	800	347/343	600/600	274/274	600/600	1845/1845
	230/60/3	551	700	308/304	500/500	243/243	506/506	1556/1556
	380/60/3	327	450	183/180	300/300	144/144	316/316	973/973
	460/60/3	270	350	151/149	250/250	119/119	252/252	774/774
	575/60/3	220	300	123/122	200/200	97/97	205/205	631/631

**Notes:**

1. Voltage Utilization Range: +/- 10% of rated voltage  
Rated voltage (use range): 208/60/3 (187.2-228.8), 230/60/3(208-254), 380/60/3 (342-418), 460/60/3 (414-506), 575/60/3 (516-633)
2. MCA–minimum circuit ampacity
3. MOP–maximum overcurrent protection
4. RLA–rated load amps are rated in accordance with UL Standard 1995.
5. LRA–locked rotor amps are based on full winding starts.
6. LRA YD–Locked Rotor Amps in Wye configuration. LRA XL–Locked Rotor Amps in the Delta configuration.
7. Local codes may take precedence.
8. Data containing information on two circuits shown as follows: circuit 1/circuit 2.
9. High condensing temperature option refers to entering condenser water temperatures above 95°F (35°C).



## Installation - Electrical

**Table 72. Electrical Data - RTUD - 60 Hz**

Unit Size	Rated Voltage	Unit Wiring				Motor Data		
		Single Point Power - 1 Power Connection		Dual Point Power - 2 Power Connections		RLA	LRA YD	LRA XL
		MCA	MOP	MCA	MOP			
80	200/60/3	297	400	167/163	250/250	130/130	276/276	912/912
	230/60/3	261	350	147/143	250/250	114/114	238/238	786/786
	380/60/3	158	225	89/87	150/150	69/69	138/138	456/456
	460/60/3	131	175	74/72	125/125	57/57	114/114	376/376
	575/60/3	105	150	59/58	100/100	46/46	93/93	308/308
90	200/60/3	353	500	198/194	350/300	155/155	304/304	1003/1003
	230/60/3	299	400	168/164	250/250	131/131	262/262	866/866
	380/60/3	185	250	104/102	175/175	81/81	161/161	530/530
	460/60/3	153	200	86/84	150/150	67/67	131/131	433/433
	575/60/3	123	175	69/68	110/110	54/54	105/105	346/346
100	200/60/3	400	500	198/240	350/400	155/192	304/355	1003/1137
	230/60/3	344	500	168/209	250/350	131/167	262/294	866/942
	380/60/3	210	300	104/127	175/225	81/101	161/177	530/566
	460/60/3	174	250	86/105	150/175	67/84	131/147	433/471
	575/60/3	140	200	69/84	110/150	54/67	105/118	346/377
110	200/60/3	437	600	245/240	400/400	192/192	355/355	1137/1137
	230/60/3	380	500	213/209	350/350	167/167	294/294	942/942
	380/60/3	230	300	129/127	225/225	101/101	177/177	566/566
	460/60/3	191	250	107/105	175/175	84/84	147/147	471/471
	575/60/3	153	200	86/84	150/150	67/67	118/118	377/377
120	200/60/3	447	600	245/250	400/450	192/200	355/419	1137/1368
	230/60/3	421	600	213/250	350/450	167/200	294/367	942/1200
	380/60/3	255	350	129/152	225/250	101/121	177/229	566/747
	460/60/3	211	300	107/125	175/225	84/100	147/184	471/600
	575/60/3	169	225	86/100	150/175	67/80	118/148	377/483
130	200/60/3	455	600	255/250	450/450	200/200	419/419	1368/1368
	230/60/3	454	600	254/250	450/450	200/200	367/367	1200/1200
	380/60/3	275	350	154/152	250/250	121/121	229/229	747/747
	460/60/3	227	300	127/125	225/225	100/100	184/184	600/600
	575/60/3	182	250	102/100	175/175	80/80	148/148	483/483
150	200/60/3	542	800	255/338	450/600	200/270	419/487	1368/1498
	230/60/3	498	700	254/294	450/500	200/235	367/427	1200/1314
	380/60/3	301	400	154/178	250/300	121/142	229/260	747/801
	460/60/3	250	350	127/148	225/250	100/118	184/212	600/652
	575/60/3	199	250	102/118	175/200	80/84	148/172	483/528
160	200/60/3	612	800	342/338	600/600	270/270	487/487	1498/1498
	230/60/3	553	700	298/294	500/500	235/235	427/427	1314/1314
	380/60/3	322	450	180/178	300/300	142/142	260/260	801/801
	460/60/3	268	350	150/148	250/250	118/118	212/212	652/652
	575/60/3	213	300	119/118	200/200	94/94	172/172	528/528
180	200/60/3	675	800	342/400	600/700	270/320	487/600	1498/1845
	230/60/3	587	800	298/348	500/600	235/278	427/506	1314/1556
	380/60/3	355	500	180/210	300/350	142/168	260/316	801/973
	460/60/3	284	400	150/164	250/250	118/131	212/252	652/774
	575/60/3	235	300	119/139	200/225	94/111	172/205	528/631



## Installation - Electrical

**Table 72. Electrical Data - RTUD - 60 Hz (continued)**

Unit Size	Rated Voltage	Unit Wiring				Motor Data		
		Single Point Power - 1 Power Connection		Dual Point Power - 2 Power Connections		RLA	LRA YD	LRA XL
		MCA	MOP	MCA	MOP			
200	200/60/3	725	1000	405/400	700/700	320/320	600/600	1845/1845
	230/60/3	630	800	352/345	600/600	278/278	506/506	1556/1556
	380/60/3	381	500	213/210	350/350	168/168	316/316	973/973
	460/60/3	297	400	166/164	250/250	131/131	252/252	774/774
	575/60/3	252	350	141/139	250/225	111/111	205/205	631/631
220	200/60/3	743	1000	405/419	700/700	320/335	600/701	1845/2156
	230/60/3	701	1000	352/419	600/700	278/335	506/571	1556/1756
	380/60/3	424	600	213/254	350/450	168/203	316/345	973/1060
	460/60/3	343	500	166/210	250/350	131/168	252/285	774/878
	575/60/3	277	400	141/164	250/250	111/131	205/229	631/705
250	200/60/3	758	1000	423/419	700/700	335/335	701/701	2156/2156
	230/60/3	758	1000	423/419	700/700	335/335	571/571	1756/1756
	380/60/3	459	600	256/254	450/450	203/203	345/345	1060/1060
	460/60/3	380	500	212/210	350/350	168/168	285/285	878/878
	575/60/3	297	400	166/164	250/250	131/131	229/229	705/705

**Notes:**

1. Voltage Utilization Range: +/- 10% of rated voltage  
Rated voltage (use range): 208/60/3 (187.2-228.8), 230/60/3(208-254), 380/60/3 (342-418), 460/60/3 (414-506), 575/60/3 (516-633)MCA–minimum circuit ampacity
2. MOP–maximum overcurrent protection
3. RLA–rated load amps are rated in accordance with UL Standard 1995.
4. LRA–locked rotor amps are based on full winding starts.
5. LRA YD–Locked Rotor Amps in Wye configuration. LRA XL–Locked Rotor Amps in the Delta configuration.
6. Local codes may take precedence.
7. Data containing information on two circuits shown as follows: circuit 1/circuit 2.
8. Standard condensing temperature option refers to entering condenser water temperatures 95°F (35°C) and below.

**Table 73. Electrical Data – Trane Air-Cooled Condenser – 60 Hz**

Unit Size	Rated Voltage	Unit Wiring					
		Standard Ambient			Low Ambient		
		Fan FLA	Fan MCA	Fan MOP	Fan FLA	Fan MCA	Fan MOP
RTUD 80	208-230/60/3	6	37.5	40	6	37.5	40
	460/60/3	3	18.8	20	3	18.8	20
	575/60/3	2.5	15.6	15	2.5	16.8	15
RTUD 90	208-230/60/3	6	49.5	50	6	49.5	50
	460/60/3	3	24.8	25	3	24.8	25
	575/60/3	2.5	20.6	20	2.5	21.8	20
RTUD 100	208-230/60/3	6	49.5	50	6	49.5	50
	460/60/3	3	24.8	25	3	24.8	25
	575/60/3	2.5	20.6	20	2.5	21.8	20
RTUD 110	208-230/60/3	6	49.5	50	6	49.5	50
	460/60/3	3	24.8	25	3	24.8	25
	575/60/3	2.5	20.6	20	2.5	21.8	20
RTUD 120	208-230/60/3	6	61.5	60	6	61.5	60
	460/60/3	3	30.8	30	3	30.8	30
	575/60/3	2.5	18.8	25	2.5	24.8	25
RTUD 130	208-230/60/3	6	61.5	60	6	61.5	60
	460/60/3	3	30.8	30	3	30.8	30
	575/60/3	2.5	18.8	25	2.5	24.8	25

## Installation - Electrical

**Table 73. Electrical Data – Trane Air-Cooled Condenser – 60 Hz (continued)**

Unit Size	Rated Voltage	Unit Wiring					
		Standard Ambient			Low Ambient		
		Fan FLA	Fan MCA	Fan MOP	Fan FLA	Fan MCA	Fan MOP
RTUD 150	208-230/60/3	6	37.5	40	6	37.5	40
	460/60/3	3	18.8	20	3	18.8	20
	575/60/3	2.5	15.6	15	2.5	16.8	15
RTUD 160	208-230/60/3	6	37.5	40	6	37.5	40
	460/60/3	3	18.8	20	3	18.8	20
	575/60/3	2.5	15.6	15	2.5	16.8	15
RTUD 180	208-230/60/3	6	37.5/49.5	40/50	6	37.5/49.5	40/50
	460/60/3	3	18.8/24.8	20/25	3	18.8/24.8	20/25
	575/60/3	2.5	15.6/20.6	15/20	2.5	16.8/21.8	15/20
RTUD 200	208-230/60/3	6	49.5	50	6	49.5	50
	460/60/3	3	24.8	25	3	24.8	25
	575/60/3	2.5	20.6	20	2.5	21.8	20
RTUD 220	208-230/60/3	6	49.5	50	6	49.5	50
	460/60/3	3	24.8	25	3	24.8	25
	575/60/3	2.5	20.6	20	2.5	21.8	20
RTUD 250	208-230/60/3	6	49.5	50	6	49.5	50
	460/60/3	3	24.8	25	3	24.8	25
	575/60/3	2.5	20.6	20	2.5	21.8	20

**Notes:**

1. MCA–minimum circuit ampacity
2. MOP–maximum overcurrent protection
3. FLA–fan rated load amps
4. Local codes may take precedence.
5. Information is the same for both circuits unless it is shown as: circuit 1/circuit 2.

**Table 74. Electrical Data - RTWD - 50 Hz - standard efficiency - standard condensing temperature**

Unit Size	Rated Voltage	Unit Wiring				Motor Data		
		Single Point Power - 1 Power Connection		Dual Point Power - 2 Power Connections		RLA	LRA YD	LRA XL
		MCA	MOP	MCA	MOP			
70	400/50/3	106	150	60/58	100/100	46/46	129/129	427/427
80	400/50/3	123	175	60/75	100/125	46/60	129/144	427/462
90	400/50/3	137	175	77/75	125/125	60/60	144/144	462/462
100	400/50/3	152	200	77/90	125/150	60/72	144/180	462/589
110	400/50/3	164	225	92/90	150/150	72/72	180/180	589/589
120	400/50/3	180	250	92/106	150/175	72/85	180/217	589/668
130	400/50/3	193	250	108/106	175/175	85/85	217/217	668/668
140	400/50/3	211	300	108/124	175/200	85/99	217/259	668/796
150	400/50/3	225	300	126/124	200/200	99/99	259/259	796/796

**Notes:**

1. Voltage Utilization Range: +/- 10% of rated voltage  
Rated voltage (use range): 400/50/3 (360-440)
2. MOP–maximum overcurrent protection
3. RLA–rated load amps are rated in accordance with UL Standard 1995.
4. LRA–locked rotor amps are based on full winding starts.
5. LRA YD–Locked Rotor Amps in Wye configuration. LRA XL–Locked Rotor Amps in the Delta configuration.
6. Local codes may take precedence.
7. Data containing information on two circuits shown as follows: circuit 1/circuit 2.
8. Standard condensing temperature option refers to entering condenser water temperatures 95°F (35°C) or below.



## Installation - Electrical

**Table 75. Electrical Data - RTWD - 50 Hz - high efficiency - standard condensing temperature**

Unit Size	Rated Voltage	Unit Wiring				Motor Data		
		Single Point Power - 1 Power Connection		Dual Point Power - 2 Power Connections		RLA	LRA YD	LRA XL
		MCA	MOP	MCA	MOP			
60	400/50/3	88	125	50/48	80/80	38/38	112/112	370/370
70	400/50/3	103	125	58/56	100/100	45/45	129/129	427/427
80	400/50/3	121	175	58/74	100/125	45/59	129/144	427/462
90	400/50/3	135	175	76/74	125/125	59/59	144/144	462/462
100	400/50/3	150	200	76/89	125/150	59/71	144/180	462/589
110	400/50/3	162	225	91/89	150/150	71/71	180/180	589/589
120	400/50/3	178	250	91/105	150/175	71/84	180/217	589/668
130	400/50/3	192	250	108/105	175/175	84/84	217/217	668/668
140	400/50/3	209	300	108/123	175/200	84/98	217/259	668/796
160	400/50/3	223	300	125/123	200/200	98/98	259/259	796/796
180	400/50/3	247	350	125/147	200/250	98/117	259/291	796/896
200	400/50/3	266	350	149/147	250/250	117/117	291/291	896/896
220	400/50/3	296	400	149/177	250/300	117/141	291/354	896/1089
250	400/50/3	320	450	179/177	300/300	141/141	354/354	1089/1089

**Notes:**

1. Voltage Utilization Range: +/- 10% of rated voltage. Rated voltage (use range): 400/50/3 (360-440)
2. MCA—minimum circuit ampacity
3. MOP—maximum overcurrent protection
4. RLA—rated load amps are rated in accordance with UL Standard 1995.
5. LRA—locked rotor amps are based on full winding starts.
6. LRA YD—Locked Rotor Amps in Wye configuration. LRA XL—Locked Rotor Amps in the Delta configuration.
7. Local codes may take precedence.
8. Data containing information on two circuits shown as follows: circuit 1/circuit 2.
9. Standard condensing temperature option refers to entering condenser water temperatures 95°F (35°C) or below.

**Table 76. Electrical Data - RTWD - 50 Hz - high efficiency - high condensing temperature**

Unit Size	Rated Voltage	Unit Wiring				Motor Data		
		Single Point Power - 1 Power Connection		Dual Point Power - 2 Power Connections		RLA	LRA YD	LRA XL
		MCA	MOP	MCA	MOP			
60	400/50/3	110	150	62/60	110/100	48/48	112/112	370/370
70	400/50/3	133	175	75/73	125/125	58/58	129/129	427/427
80	400/50/3	153	225	75/93	125/150	58/74	129/144	427/462
90	400/50/3	169	225	95/93	150/150	74/74	144/144	462/462
100	400/50/3	186	250	95/110	150/175	74/88	144/180	462/589
110	400/50/3	200	250	112/110	200/175	88/88	180/180	589/589
120	400/50/3	215	300	112/125	200/225	88/100	180/217	589/668
130	400/50/3	226	300	128/123	225/200	100/98	217/217	668/668
150	400/50/3	250	350	128/148	225/250	100/118	217/259	668/796
160	400/50/3	268	350	150/148	250/250	118/118	259/259	796/796
180	400/50/3	297	400	150/177	250/300	118/141	259/291	796/896
200	400/50/3	320	450	179/177	300/300	141/141	291/291	896/896
220	400/50/3	352	500	179/209	300/350	141/167	291/354	896/1089
250	400/50/3	378	500	211/209	350/350	167/167	354/354	1089/1089

**Notes:**

1. Voltage Utilization Range: +/- 10% of rated voltage. Rated voltage (use range): 400/50/3 (360-440)
2. MCA—minimum circuit ampacity
3. MOP—maximum overcurrent protection
4. RLA—rated load amps are rated in accordance with UL Standard 1995.
5. LRA—locked rotor amps are based on full winding starts.
6. LRA YD—Locked Rotor Amps in Wye configuration. LRA XL—Locked Rotor Amps in the Delta configuration.
7. Local codes may take precedence.
8. Data containing information on two circuits shown as follows: circuit 1/circuit 2.
9. High condensing temperature option refers to entering condenser water temperatures above 95°F (35°C).

## Installation - Electrical

**Table 77. Electrical Data - RTWD - 50 Hz - premium efficiency - standard condensing temperature**

Unit Size	Rated Voltage	Unit Wiring				Motor Data		
		Single Point Power - 1 Power Connection		Dual Point Power - 2 Power Connections		RLA	LRA YD	LRA XL
		MCA	MOP	MCA	MOP			
160	400/50/3	221	300	124/122	200/200	97/97	259/259	796/796
180	400/50/3	246	350	124/147	200/250	97/117	259/291	796/896
200	400/50/3	266	350	149/147	250/250	117/117	291/291	896/896

**Notes:**

1. Voltage Utilization Range: +/- 10% of rated voltage. Rated voltage (use range): 400/50/3 (360-440)
2. MCA—minimum circuit ampacity
3. MOP—maximum overcurrent protection
4. RLA—rated load amps are rated in accordance with UL Standard 1995.
5. LRA—locked rotor amps are based on full winding starts.
6. LRA YD—Locked Rotor Amps in Wye configuration. LRA XL—Locked Rotor Amps in the Delta configuration.
7. Local codes may take precedence.
8. Data containing information on two circuits shown as follows: circuit 1/circuit 2.
9. Standard condensing temperature option refers to entering condenser water temperatures 95°F (35°C) or below.

**Table 78. Electrical Data - RTWD - 50 Hz - premium efficiency - high condensing temperature**

Unit Size	Rated Voltage	Unit Wiring				Motor Data		
		Single Point Power - 1 Power Connection		Dual Point Power - 2 Power Connections		RLA	LRA YD	LRA XL
		MCA	MOP	MCA	MOP			
160	400/50/3	268	350	150/148	250/250	118/118	259/259	796/796
180	400/50/3	297	400	150/177	250/300	118/141	259/291	796/896
200	400/50/3	320	450	179/177	300/300	141/141	291/291	896/896

**Notes:**

1. MCA—minimum circuit ampacity
2. MOP—maximum overcurrent protection
3. RLA—rated load amps are rated in accordance with UL Standard 1995.
4. LRA—locked rotor amps are based on full winding starts.
5. LRA YD—Locked Rotor Amps in Wye configuration. LRA XL—Locked Rotor Amps in the Delta configuration.
6. Local codes may take precedence.
7. Data containing information on two circuits shown as follows: circuit 1/circuit 2.
8. High condensing temperature option refers to entering condenser water temperatures above 95°F (35°C).

**Table 79. Customer Wire Selection - RTWD - 60 Hz - standard efficiency - standard condensing temperature**

Wire Selection														
Rated Size	# Voltage Conn	Main Terminal Block			Disconnect			Circuit Breaker			Hi-Fault Panel Ckt Brkr			
		Size Amp	Wire Range XL	Wire Range YD	Size Amp	Wire Range XL	Wire Range YD	Size Amp	Wire Range XL	Wire Range YD	Size Amp	Wire Range XL	Wire Range YD	
80	200	1	380	N/A	#4-500	250	N/A	#6-350	300	N/A	3/0-500 <sup>(a)</sup>	300	N/A	3/0-500 <sup>(a)</sup>
		2	175	N/A	#14-2/0	250	N/A	#6-350	200	N/A	#6-350	200	N/A	#6-350
	230	1	380	N/A	#4-500	250	N/A	#6-350	250	N/A	#6-350	250	N/A	#6-350
		2	175	N/A	#14-2/0	100	N/A	#10-1/0	175	N/A	#6-350	175	N/A	#6-350
	380	1	380	#4-500	#4-500	250	#6-350	#6-350	150	#6-350	#6-350	150	#6-350	#6-350
		2	175	#14-2/0	#14-2/0	100	#10-1/0	#10-1/0	110	#6-350	#6-350	110	#6-350	#6-350
	460	1	380	#4-500	#4-500	100	#10-1/0	#10-1/0	125	#6-350	#6-350	125	#6-350	#6-350
		2	175	#14-2/0	#14-2/0	100	#10-1/0	#10-1/0	90	#6-350	#6-350	90	#6-350	#6-350
	575	1	380	#4-500	#4-500	100	#10-1/0	#10-1/0	100	#6-350	#6-350	N/A	N/A	N/A
		2	175	#14-2/0	#14-2/0	100	#10-1/0	#10-1/0	70	#6-350	#6-350	N/A	N/A	N/A



## Installation - Electrical

**Table 79. Customer Wire Selection - RTWD - 60 Hz - standard efficiency - standard condensing temperature (continued)**

		Wire Selection													
Rated Size	# Voltage Conn	Main Terminal Block			Disconnect			Circuit Breaker			Hi-Fault Panel Ckt Brkr				
		Size Amp	Wire Range XL	Wire Range YD	Size Amp	Wire Range XL	Wire Range YD	Size Amp	Wire Range XL	Wire Range YD	Size Amp	Wire Range XL	Wire Range YD		
90	200	1	380	N/A	#4-500	400	N/A	3/0-500 <sup>(a)</sup>	350	N/A	3/0-500 <sup>(a)</sup>	350	N/A	3/0-500 <sup>(a)</sup>	
		2	175	N/A	#14-2/0	250	N/A	#6-350	225	N/A	#6-350	225	N/A	#6-350	
	230	1	380	N/A	#4-500	250	N/A	#6-350	300	N/A	3/0-500 <sup>(a)</sup>	300	N/A	3/0-500 <sup>(a)</sup>	
		2	175	N/A	#14-2/0	250	N/A	#6-350	200	N/A	#6-350	200	N/A	#6-350	
	380	1	380	#4-500	#4-500	250	#6-350	#6-350	175	#6-350	#6-350	175	#6-350	#6-350	
		2	175	#14-2/0	#14-2/0	100	#10-1/0	#10-1/0	125	#6-350	#6-350	125	#6-350	#6-350	
	460	1	380	#4-500	#4-500	250	#6-350	#6-350	150	#6-350	#6-350	150	#6-350	#6-350	
		2	175	#14-2/0	#14-2/0	100	#10-1/0	#10-1/0	100	#6-350	#6-350	100	#6-350	#6-350	
	575	1	380	#4-500	#4-500	100	#10-1/0	#10-1/0	110	#6-350	#6-350	N/A	N/A	N/A	
		2	175	#14-2/0	#14-2/0	100	#10-1/0	#10-1/0	80	#6-350	#6-350	N/A	N/A	N/A	
100	200	1	380	N/A	#4-500	400	N/A	3/0-500 <sup>(a)</sup>	400	N/A	3/0-500 <sup>(a)</sup>	400	N/A	3/0-500 <sup>(a)</sup>	
		2	175	N/A	#14-2/0	250	N/A	#6-350	225	N/A	#6-350	225	N/A	#6-350	
	230	1	380	N/A	#4-500	400	N/A	3/0-500 <sup>(a)</sup>	350	N/A	3/0-500 <sup>(a)</sup>	350	N/A	3/0-500 <sup>(a)</sup>	
		2	175	N/A	#14-2/0	250	N/A	#6-350	200	N/A	#6-350	200	N/A	#6-350	
	380	1	380	#4-500	#4-500	250	#6-350	#6-350	225	#6-350	#6-350	225	#6-350	#6-350	
		2	175	#14-2/0	#14-2/0	100	#10-1/0	#10-1/0	125	#6-350	#6-350	125	#6-350	#6-350	
	460	1	380	#4-500	#4-500	250	#6-350	#6-350	175	#6-350	#6-350	175	#6-350	#6-350	
		2	175	#14-2/0	#14-2/0	100	#10-1/0	#10-1/0	100	#6-350	#6-350	100	#6-350	#6-350	
	575	1	380	#4-500	#4-500	250	#6-350	#6-350	150	#6-350	#6-350	N/A	N/A	N/A	
		2	175	#14-2/0	#14-2/0	100	#10-1/0	#10-1/0	80	#6-350	#6-350	N/A	N/A	N/A	
110	200	1	380	N/A	#4-500	400	N/A	3/0-500 <sup>(a)</sup>	450	N/A	3/0-500 <sup>(a)</sup>	450	N/A	3/0-500 <sup>(a)</sup>	
		2	380	N/A	#4-500	250	N/A	#6-350	300	N/A	3/0-500 <sup>(a)</sup>	300	N/A	3/0-500 <sup>(a)</sup>	
	230	1	380	N/A	#4-500	400	N/A	3/0-500 <sup>(a)</sup>	400	N/A	3/0-500 <sup>(a)</sup>	400	N/A	3/0-500 <sup>(a)</sup>	
		2	175	N/A	#14-2/0	250	N/A	#6-350	250	N/A	#6-350	250	N/A	#6-350	
	380	1	380	#4-500	#4-500	250	#6-350	#6-350	225	#6-350	#6-350	225	#6-350	#6-350	
		2	175	#14-2/0	#14-2/0	100	#10-1/0	#10-1/0	150	#6-350	#6-350	150	#6-350	#6-350	
	460	1	380	#4-500	#4-500	250	#6-350	#6-350	200	#6-350	#6-350	200	#6-350	#6-350	
		2	175	#14-2/0	#14-2/0	100	#10-1/0	#10-1/0	125	#6-350	#6-350	125	#6-350	#6-350	
	575	1	380	#4-500	#4-500	250	#6-350	#6-350	150	#6-350	#6-350	N/A	N/A	N/A	
		2	175	#14-2/0	#14-2/0	100	#10-1/0	#10-1/0	110	#6-350	#6-350	N/A	N/A	N/A	
120	200	1	380	N/A	#4-500	400	N/A	3/0-500 <sup>(a)</sup>	500	N/A	3/0-500 <sup>(a)</sup>	500	N/A	3/0-500 <sup>(a)</sup>	
		2	380	N/A	#4-500	250	N/A	#6-350	300	N/A	3/0-500 <sup>(a)</sup>	300	N/A	3/0-500 <sup>(a)</sup>	
	230	1	380	N/A	#4-500	400	N/A	3/0-500 <sup>(a)</sup>	450	N/A	3/0-500 <sup>(a)</sup>	450	N/A	3/0-500 <sup>(a)</sup>	
		2	175	N/A	#14-2/0	250	N/A	#6-350	250	N/A	#6-350	250	N/A	#6-350	
	380	1	380	#4-500	#4-500	250	#6-350	#6-350	250	#6-350	#6-350	250	#6-350	#6-350	
		2	175	#14-2/0	#14-2/0	100	#10-1/0	#10-1/0	150	#6-350	#6-350	150	#6-350	#6-350	
	460	1	380	#4-500	#4-500	250	#6-350	#6-350	225	#6-350	#6-350	225	#6-350	#6-350	
		2	175	#14-2/0	#14-2/0	100	#10-1/0	#10-1/0	125	#6-350	#6-350	125	#6-350	#6-350	
	575	1	380	#4-500	#4-500	250	#6-350	#6-350	175	#6-350	#6-350	N/A	N/A	N/A	
		2	175	#14-2/0	#14-2/0	100	#10-1/0	#10-1/0	110	#6-350	#6-350	N/A	N/A	N/A	

## Installation - Electrical

**Table 79. Customer Wire Selection - RTWD - 60 Hz - standard efficiency - standard condensing temperature (continued)**

Rated # Size Voltage Conn		Wire Selection													
		Main Terminal Block			Disconnect			Circuit Breaker			Hi-Fault Panel Ckt Brkr				
		Size Amp	Wire Range XL YD		Size Amp	Wire Range XL YD		Size Amp	Wire Range XL YD		Size Amp	Wire Range XL YD			
130	200	1	380	N/A	#4-500	400	N/A	3/0-500 <sup>(a)</sup>	500	N/A	3/0-500 <sup>(a)</sup>	500	N/A	3/0-500 <sup>(a)</sup>	
		2	380	N/A	#4-500	250	N/A	#6-350	350	N/A	3/0-500 <sup>(a)</sup>	350	N/A	3/0-500 <sup>(a)</sup>	
	230	1	380	N/A	#4-500	400	N/A	3/0-500 <sup>(a)</sup>	450	N/A	3/0-500 <sup>(a)</sup>	450	N/A	3/0-500 <sup>(a)</sup>	
		2	175 380	N/A	#14-2/0 #4-500	250	N/A	#6-350	300	N/A	3/0-500 <sup>(a)</sup>	300	N/A	3/0-500 <sup>(a)</sup>	
	380	1	380	#4-500	#4-500	250	#6-350	#6-350	250	#6-350	#6-350	250	#6-350	#6-350	
		2	175	#14-2/0	#14-2/0	250	#6-350	#6-350	200 175	#6-350	#6-350	200 175	#6-350	#6-350	
	460	1	380	#4-500	#4-500	250	#6-350	#6-350	225	#6-350	#6-350	225	#6-350	#6-350	
		2	175	#14-2/0	#14-2/0	100	#10-1/0	#10-1/0	150	#6-350	#6-350	150	#6-350	#6-350	
	575	1	380	#4-500	#4-500	250	#6-350	#6-350	175	#6-350	#6-350	N/A	N/A	N/A	
		2	175	#14-2/0	#14-2/0	100	#10-1/0	#10-1/0	125	#6-350	#6-350	N/A	N/A	N/A	
	140	200	1	760	N/A	#4-500 <sup>(a)</sup>	600	N/A	3/0-500 <sup>(a)</sup>	600	N/A	3/0-500 <sup>(a)</sup>	600	N/A	3/0-500 <sup>(a)</sup>
			2	380	N/A	#4-500	250	N/A	#6-350	350 450	N/A	3/0-500 <sup>(a)</sup>	350 450	N/A	3/0-500 <sup>(a)</sup>
230		1	380	N/A	#4-500	400	N/A	3/0-500 <sup>(a)</sup>	500	N/A	3/0-500 <sup>(a)</sup>	500	N/A	3/0-500 <sup>(a)</sup>	
		2	380	N/A	#4-500	250	N/A	#6-350	300 350	N/A	3/0-500 <sup>(a)</sup>	300 350	N/A	3/0-500 <sup>(a)</sup>	
380		1	380	#4-500	#4-500	250	#6-350	#6-350	300	3/0-500 <sup>(a)</sup>	3/0-500 <sup>(a)</sup>	300	3/0-500 <sup>(a)</sup>	3/0-500 <sup>(a)</sup>	
		2	175	#14-2/0	#14-2/0	250	#6-350	#6-350	200 225	#6-350	#6-350	200 225	#6-350	#6-350	
460		1	380	#4-500	#4-500	250	#6-350	#6-350	250	#6-350	#6-350	250	#6-350	#6-350	
		2	175	#14-2/0	#14-2/0	100 250	#10-1/0 #6-350	#10-1/0 #6-350	150 175	#6-350	#6-350	150 175	#6-350	#6-350	
575		1	380	#4-500	#4-500	250	#6-350	#6-350	200	#6-350	#6-350	N/A	N/A	N/A	
		2	175	#14-2/0	#14-2/0	100	#10-1/0	#10-1/0	125 150	#6-350	#6-350	N/A	N/A	N/A	

**Notes:**

1. Optional non-fused disconnect and circuit breaker.
2. Copper wire only, based on nameplate minimum circuit ampacity (MCA).
3. Standard condensing temperature option refers to entering condenser water temperatures 95°F (35°C) and below.
4. Circuit two information is the same as circuit one unless listed on a separate line below circuit one values.
5. XL - across-the-line starter and YD - wye-delta starter.

(a) Will accept 2 conduits per phase in this size.

**Table 80. Customer Wire Selection - RTWD - 60 Hz - high efficiency - standard condensing temperature**

Rated # Size Voltage Conn		Wire Selection												
		Main Terminal Block			Disconnect			Circuit Breaker			Hi-Fault Panel Ckt Brkr			
		Size Amp	Wire Range XL YD		Size Amp	Wire Range XL YD		Size Amp	Wire Range XL YD		Size Amp	Wire Range XL YD		
80	200	1	380	N/A	#4-500	250	N/A	#6-350	300	N/A	3/0-500 <sup>(a)</sup>	300	N/A	3/0-500 <sup>(a)</sup>
		2	175	N/A	#14-2/0	250	N/A	#6-350	200	N/A	#6-350	200	N/A	#6-350
	230	1	380	N/A	#4-500	250	N/A	#6-350	250	N/A	#6-350	250	N/A	#6-350
		2	175	N/A	#14-2/0	100	N/A	#10-1/0	175	N/A	#6-350	175	N/A	#6-350
	380	1	380	#4-500	#4-500	250	#6-350	#6-350	150	#6-350	#6-350	150	#6-350	#6-350
		2	175	#14-2/0	#14-2/0	100	#10-1/0	#10-1/0	110	#6-350	#6-350	110	#6-350	#6-350
460	1	380	#4-500	#4-500	100	#10-1/0	#10-1/0	125	#6-350	#6-350	125	#6-350	#6-350	
	2	175	#14-2/0	#14-2/0	100	#10-1/0	#10-1/0	90	#6-350	#6-350	90	#6-350	#6-350	
575	1	380	#4-500	#4-500	100	#10-1/0	#10-1/0	100	#6-350	#6-350	N/A	N/A	N/A	
	2	175	#14-2/0	#14-2/0	100	#10-1/0	#10-1/0	70	#6-350	#6-350	N/A	N/A	N/A	



## Installation - Electrical

**Table 80. Customer Wire Selection - RTWD - 60 Hz - high efficiency - standard condensing temperature (continued)**

Rated Size	# Voltage Conn	Wire Selection												
		Main Terminal Block			Disconnect			Circuit Breaker			Hi-Fault Panel Ckt Brkr			
		Size Amp	Wire Range XL	Wire Range YD	Size Amp	Wire Range XL	Wire Range YD	Size Amp	Wire Range XL	Wire Range YD	Size Amp	Wire Range XL	Wire Range YD	
90	200	1	380	N/A	#4-500	250	N/A	#6-350	350	N/A	3/0-500 <sup>(a)</sup>	350	N/A	3/0-500 <sup>(a)</sup>
		2	175	N/A	#14-2/0	250	N/A	#6-350	225	N/A	#6-350	225	N/A	#6-350
	230	1	380	N/A	#4-500	250	N/A	#6-350	300	N/A	3/0-500 <sup>(a)</sup>	300	N/A	3/0-500 <sup>(a)</sup>
		2	175	N/A	#14-2/0	250	N/A	#6-350	200	N/A	#6-350	200	N/A	#6-350
	380	1	380	#4-500	#4-500	250	#6-350	#6-350	175	#6-350	#6-350	175	#6-350	#6-350
		2	175	#14-2/0	#14-2/0	100	#10-1/0	#10-1/0	125	#6-350	#6-350	125	#6-350	#6-350
	460	1	380	#4-500	#4-500	250	#6-350	#6-350	150	#6-350	#6-350	150	#6-350	#6-350
		2	175	#14-2/0	#14-2/0	100	#10-1/0	#10-1/0	100	#6-350	#6-350	100	#6-350	#6-350
	575	1	380	#4-500	#4-500	100	#10-1/0	#10-1/0	110	#6-350	#6-350	N/A	N/A	N/A
		2	175	#14-2/0	#14-2/0	100	#10-1/0	#10-1/0	80	#6-350	#6-350	N/A	N/A	N/A
100	200	1	380	N/A	#4-500	400	N/A	3/0-500 <sup>(a)</sup>	400	N/A	3/0-500 <sup>(a)</sup>	400	N/A	3/0-500 <sup>(a)</sup>
		2	175	N/A	#14-2/0	250	N/A	#6-350	225 300	N/A #6-350 3/0-500 <sup>(a)</sup>	225 300	N/A #6-350 3/0-500 <sup>(a)</sup>		
	230	1	380	N/A	#4-500	250	N/A	#6-350	350	N/A	3/0-500 <sup>(a)</sup>	350	N/A	3/0-500 <sup>(a)</sup>
		2	175	N/A	#14-2/0	250	N/A	#6-350	200 250	N/A #6-350	200 250	N/A #6-350		
	380	1	380	#4-500	#4-500	250	#6-350	#6-350	200	#6-350	#6-350	200	#6-350	#6-350
		2	175	#14-2/0	#14-2/0	100	#10-1/0	#10-1/0	125 150	#6-350 #6-350	125 150	#6-350 #6-350		
	460	1	380	#4-500	#4-500	250	#6-350	#6-350	175	#6-350	#6-350	175	#6-350	#6-350
		2	175	#14-2/0	#14-2/0	100	#10-1/0	#10-1/0	100 125	#6-350 #6-350	100 125	#6-350 #6-350		
	575	1	380	#4-500	#4-500	100	#10-1/0	#10-1/0	125	#6-350	#6-350	N/A	N/A	N/A
		2	175	#14-2/0	#14-2/0	100	#10-1/0	#10-1/0	80 100	#6-350 #6-350	80 100	N/A #6-350	N/A #6-350	
110	200	1	380	N/A	#4-500	400	N/A	3/0-500 <sup>(a)</sup>	450	N/A	3/0-500 <sup>(a)</sup>	450	N/A	3/0-500 <sup>(a)</sup>
		2	380 175	N/A	#4-500 #14-2/0	250	N/A	#6-350	300	N/A	3/0-500 <sup>(a)</sup>	300	N/A	3/0-500 <sup>(a)</sup>
	230	1	380	N/A	#4-500	400	N/A	3/0-500 <sup>(a)</sup>	350	N/A	3/0-500 <sup>(a)</sup>	350	N/A	3/0-500 <sup>(a)</sup>
		2	175	N/A	#14-2/0	250	N/A	#6-350	250	N/A	#6-350	250	N/A	#6-350
	380	1	380	#4-500	#4-500	250	#6-350	#6-350	225	#6-350	#6-350	225	#6-350	#6-350
		2	175	#14-2/0	#14-2/0	100	#10-1/0	#10-1/0	150	#6-350	#6-350	150	#6-350	#6-350
	460	1	380	#4-500	#4-500	250	#6-350	#6-350	175	#6-350	#6-350	175	#6-350	#6-350
		2	175	#14-2/0	#14-2/0	100	#10-1/0	#10-1/0	125	#6-350	#6-350	125	#6-350	#6-350
	575	1	380	#4-500	#4-500	250	#6-350	#6-350	150	#6-350	#6-350	N/A	N/A	N/A
		2	175	#14-2/0	#14-2/0	100	#10-1/0	#10-1/0	100	#6-350	#6-350	N/A	N/A	N/A
120	200	1	760	N/A	#4-500 <sup>(a)</sup>	400	N/A	3/0-500 <sup>(a)</sup>	500	N/A	3/0-500 <sup>(a)</sup>	500	N/A	3/0-500 <sup>(a)</sup>
		2	380	N/A	#4-500	250	N/A	#6-350	300 350	N/A #6-350 3/0-500 <sup>(a)</sup>	300 350	N/A #6-350 3/0-500 <sup>(a)</sup>		
	230	1	380	N/A	#4-500	400	N/A	3/0-500 <sup>(a)</sup>	400	N/A	3/0-500 <sup>(a)</sup>	400	N/A	3/0-500 <sup>(a)</sup>
		2	380	N/A	#4-500	250	N/A	#6-350	250 300	N/A #6-350 3/0-500 <sup>(a)</sup>	250 300	N/A #6-350 3/0-500 <sup>(a)</sup>		
	380	1	380	#4-500	#4-500	250	#6-350	#6-350	250	#6-350	#6-350	250	#6-350	#6-350
		2	175	#14-2/0	#14-2/0	100 250	#10-1/0 #6-350	#10-1/0 #6-350	150 175	#6-350 #6-350	150 175	#6-350 #6-350		
	460	1	380	#4-500	#4-500	250	#6-350	#6-350	200	#6-350	#6-350	200	#6-350	#6-350
		2	175	#14-2/0	#14-2/0	100	#10-1/0	#10-1/0	125 150	#6-350 #6-350	125 150	#6-350 #6-350		
	575	1	380	#4-500	#4-500	250	#6-350	#6-350	175	#6-350	#6-350	N/A	N/A	N/A
		2	175	#14-2/0	#14-2/0	100	#10-1/0	#10-1/0	100 125	#6-350 #6-350	100 125	N/A #6-350	N/A #6-350	



## Installation - Electrical

**Table 80. Customer Wire Selection - RTWD - 60 Hz - high efficiency - standard condensing temperature (continued)**

Rated Size	# Voltage Conn	Wire Selection												
		Main Terminal Block			Disconnect			Circuit Breaker			Hi-Fault Panel Ckt Brkr			
		Size Amp	Wire Range XL	Wire Range YD	Size Amp	Wire Range XL	Wire Range YD	Size Amp	Wire Range XL	Wire Range YD	Size Amp	Wire Range XL	Wire Range YD	
130	200	1	380	N/A	#4-500	400	N/A	3/0-500 <sup>(a)</sup>	500	N/A	3/0-500 <sup>(a)</sup>	500	N/A	3/0-500 <sup>(a)</sup>
		2	380	N/A	#4-500	250	N/A	#6-350	350	N/A	3/0-500 <sup>(a)</sup>	350	N/A	3/0-500 <sup>(a)</sup>
	230	1	380	N/A	#4-500	400	N/A	3/0-500 <sup>(a)</sup>	450	N/A	3/0-500 <sup>(a)</sup>	450	N/A	3/0-500 <sup>(a)</sup>
		2	380	N/A	#4-500	250	N/A	#6-350	300	N/A	3/0-500 <sup>(a)</sup>	300	N/A	3/0-500 <sup>(a)</sup>
	380	1	380	#4-500	#4-500	250	#6-350	#6-350	250	#6-350	#6-350	250	#6-350	#6-350
		2	175	#14-2/0	#14-2/0	250	#6-350	#6-350	175	#6-350	#6-350	175	#6-350	#6-350
	460	1	380	#4-500	#4-500	250	#6-350	#6-350	225	#6-350	#6-350	225	#6-350	#6-350
		2	175	#14-2/0	#14-2/0	100	#10-1/0	#10-1/0	150	#6-350	#6-350	150	#6-350	#6-350
	575	1	380	#4-500	#4-500	250	#6-350	#6-350	175	#6-350	#6-350	N/A	N/A	N/A
		2	175	#14-2/0	#14-2/0	100	#10-1/0	#10-1/0	125	#6-350	#6-350	N/A	N/A	N/A
150	200	1	760	N/A	#4-500 <sup>(a)</sup>	600	N/A	3/0-500 <sup>(a)</sup>	600	N/A	3/0-500 <sup>(a)</sup>	600	N/A	3/0-500 <sup>(a)</sup>
		2	380	N/A	#4-500	250	N/A	#6-350	350 400	N/A	3/0-500 <sup>(a)</sup>	350 400	N/A	3/0-500 <sup>(a)</sup>
	230	1	380	N/A	#4-500	400	N/A	3/0-500 <sup>(a)</sup>	500	N/A	3/0-500 <sup>(a)</sup>	500	N/A	3/0-500 <sup>(a)</sup>
		2	380	N/A	#4-500	250	N/A	#6-350	300 350	N/A	3/0-500 <sup>(a)</sup>	300 350	N/A	3/0-500 <sup>(a)</sup>
	380	1	380	#4-500	#4-500	250	#6-350	#6-350	300	3/0-500	3/0-500 <sup>(a)</sup>	300	3/0-500	3/0-500 <sup>(a)</sup>
		2	175	#14-2/0	#14-2/0	250	#6-350	#6-350	175 225	#6-350	#6-350	175 225	#6-350	#6-350
	460	1	380	#4-500	#4-500	250	#6-350	#6-350	250	3/0-500 <sup>(a)</sup>	3/0-500 <sup>(a)</sup>	250	3/0-500 <sup>(a)</sup>	3/0-500 <sup>(a)</sup>
		2	175	#14-2/0	#14-2/0	100	#10-1/0	#10-1/0	150 175	#6-350	#6-350	150 175	#6-350	#6-350
	575	1	175	#14-2/0	#14-2/0	250	#6-350	#6-350	200	#6-350	#6-350	N/A	N/A	N/A
		2	175	#14-2/0	#14-2/0	100	#10-1/0	#10-1/0	125 150	#6-350	#6-350	N/A	N/A	N/A
160	200	1	760	N/A	#4-500 <sup>(a)</sup>	600	N/A	3/0-500 <sup>(a)</sup>	600	N/A	3/0-500 <sup>(a)</sup>	600	N/A	3/0-500 <sup>(a)</sup>
		2	380	N/A	#4-500	250	N/A	#6-350	400	N/A	3/0-500 <sup>(a)</sup>	400	N/A	3/0-500 <sup>(a)</sup>
	230	1	760	N/A	#4-500 <sup>(a)</sup>	400	N/A	3/0-500 <sup>(a)</sup>	500	N/A	3/0-500 <sup>(a)</sup>	500	N/A	3/0-500 <sup>(a)</sup>
		2	380	N/A	#4-500	250	N/A	#6-350	350	N/A	3/0-500 <sup>(a)</sup>	350	N/A	3/0-500 <sup>(a)</sup>
	380	1	380	#4-500	#4-500	250	#6-350	#6-350	300	3/0-500 <sup>(a)</sup>	3/0-500 <sup>(a)</sup>	300	3/0-500 <sup>(a)</sup>	3/0-500 <sup>(a)</sup>
		2	175	#14-2/0	#14-2/0	250	#6-350	#6-350	225	#6-350	#6-350	225	#6-350	#6-350
	460	1	380	#4-500	#4-500	250	#6-350	#6-350	250	3/0-500 <sup>(a)</sup>	3/0-500 <sup>(a)</sup>	250	3/0-500 <sup>(a)</sup>	3/0-500 <sup>(a)</sup>
		2	175	#14-2/0	#14-2/0	250 100	#6-350 #10-1/0	#6-350 #10-1/0	175	#6-350	#6-350	175	#6-350	#6-350
	575	1	175	#14-2/0	#14-2/0	250	#6-350	#6-350	225	#6-350	#6-350	N/A	N/A	N/A
		2	175	#14-2/0	#14-2/0	100	#10-1/0	#10-1/0	150	#6-350	#6-350	N/A	N/A	N/A
180	200	1	760	N/A	#4-500 <sup>(a)</sup>	600	N/A	3/0-500 <sup>(a)</sup>	700	N/A	#1-500 <sup>(b)</sup>	700	N/A	#1-500 <sup>(b)</sup>
		2	380	N/A	#4-500	250 400	N/A	#6-350 3/0-500 <sup>(a)</sup>	400 500	N/A	3/0-500 <sup>(a)</sup>	400 500	N/A	3/0-500 <sup>(a)</sup>
	230	1	760	N/A	#4-500 <sup>(a)</sup>	600	N/A	3/0-500 <sup>(a)</sup>	600	N/A	3/0-500 <sup>(a)</sup>	600	N/A	3/0-500 <sup>(a)</sup>
		2	380	N/A	#4-500	250	N/A	#6-350	350 400	N/A	3/0-500 <sup>(a)</sup>	350 400	N/A	3/0-500 <sup>(a)</sup>
	380	1	380	#4-500	#4-500	400	3/0-500 <sup>(a)</sup>	3/0-500 <sup>(a)</sup>	350	3/0-500 <sup>(a)</sup>	3/0-500 <sup>(a)</sup>	350	3/0-500 <sup>(a)</sup>	3/0-500 <sup>(a)</sup>
		2	XL 175/ 380 YD 175	#14-2/0 #4-500	#14-2/0	250	#6-350	#6-350	225 250	#6-350	#6-350	225 250	#6-350	#6-350
	460	1	380	#4-500	#4-500	250	#6-350	#6-350	300	3/0-500 <sup>(a)</sup>	3/0-500 <sup>(a)</sup>	300	3/0-500 <sup>(a)</sup>	3/0-500 <sup>(a)</sup>
		2	175	#14-2/0	#14-2/0	250	#6-350	#6-350	175 225	#6-350	#6-350	175 225	#6-350	#6-350
	575	1	175	#14-2/0	#14-2/0	250	#6-350	#6-350	250	#6-350	#6-350	N/A	N/A	N/A
		2	175	#14-2/0	#14-2/0	100	#10-1/0	#10-1/0	150 175	#6-350	#6-350	N/A	N/A	N/A



## Installation - Electrical

**Table 80. Customer Wire Selection - RTWD - 60 Hz - high efficiency - standard condensing temperature (continued)**

Rated Size	# Voltage Conn	Wire Selection												
		Main Terminal Block			Disconnect			Circuit Breaker			Hi-Fault Panel Ckt Brkr			
		Size Amp	Wire Range XL YD		Size Amp	Wire Range XL YD		Size Amp	Wire Range XL YD		Size Amp	Wire Range XL YD		
200	1	760	N/A	#4-500 <sup>(a)</sup>	600	N/A	3/0-500 <sup>(a)</sup>	700	N/A	#1-500	700	N/A	#1-500	
		380	N/A	#4-500	400	N/A	3/0-500 <sup>(a)</sup>	500	N/A	3/0-500 <sup>(a)</sup>	500	N/A	3/0-500 <sup>(a)</sup>	
	230	1	760	N/A	#4-500 <sup>(a)</sup>	600	N/A	3/0-500 <sup>(a)</sup>	600	N/A	3/0-500 <sup>(a)</sup>	600	N/A	3/0-500 <sup>(a)</sup>
		2	380	N/A	#4-500	250	N/A	#6-350	400	N/A	3/0-500 <sup>(a)</sup>	400	N/A	3/0-500 <sup>(a)</sup>
	380	1	380	#4-500	#4-500	400	3/0-500 <sup>(a)</sup>	3/0-500 <sup>(a)</sup>	350	3/0-500 <sup>(a)</sup>	3/0-500 <sup>(a)</sup>	350	3/0-500 <sup>(a)</sup>	3/0-500 <sup>(a)</sup>
		2	XL 380 YD 175	#4-500	#14-2/0	250	#6-350	#6-350	250	#6-350	#6-350	250	#6-350	#6-350
	460	1	380	#4-500	#4-500	250	#6-350	#6-350	300	3/0-500 <sup>(a)</sup>	3/0-500 <sup>(a)</sup>	300	3/0-500 <sup>(a)</sup>	3/0-500 <sup>(a)</sup>
		2	175	#14-2/0	#14-2/0	250	#6-350	#6-350	225	#6-350	#6-350	225	#6-350	#6-350
	575	1	380	#4-500	#4-500	250	#6-350	#6-350	250	3/0-500 <sup>(a)</sup>	3/0-500 <sup>(a)</sup>	N/A	N/A	N/A
		2	175	#14-2/0	#14-2/0	100	#10-1/0	#10-1/0	175	#6-350	#6-350	N/A	N/A	N/A
220	1	760	N/A	#4-500 <sup>(a)</sup>	600	N/A	3/0-500 <sup>(a)</sup>	800	N/A	#1-500 <sup>(b)</sup>	800	N/A	#1-500 <sup>(b)</sup>	
		380	N/A	#4-500	400	N/A	3/0-500 <sup>(a)</sup>	500 600	N/A	3/0-500 <sup>(a)</sup>	500 600	N/A	3/0-500 <sup>(a)</sup>	
	230	1	760	N/A	#4-500 <sup>(a)</sup>	600	N/A	3/0-500 <sup>(a)</sup>	700	N/A	#1-500 <sup>(b)</sup>	700	N/A	#1-500 <sup>(b)</sup>
		2	380	N/A	#4-500	250 400	N/A	#6-350 3/0-500 <sup>(a)</sup>	400 500	N/A	3/0-500 <sup>(a)</sup>	400 500	N/A	3/0-500 <sup>(a)</sup>
	380	1	380	#4-500	#4-500	400	3/0-500 <sup>(a)</sup>	3/0-500 <sup>(a)</sup>	450	3/0-500 <sup>(a)</sup>	3/0-500 <sup>(a)</sup>	450	3/0-500 <sup>(a)</sup>	3/0-500 <sup>(a)</sup>
		2	XL 380 YD 175 380	#4-500	#14-2/0 #4-500	250	#6-350	#6-350	250 300	#6-350 3/0-500 <sup>(a)</sup>	#6-350 3/0-500 <sup>(a)</sup>	250 300	#6-350 3/0-500 <sup>(a)</sup>	#6-350 3/0-500 <sup>(a)</sup>
	460	1	380	#4-500	#4-500	400	3/0-500 <sup>(a)</sup>	3/0-500 <sup>(a)</sup>	350	3/0-500 <sup>(a)</sup>	3/0-500 <sup>(a)</sup>	350	3/0-500 <sup>(a)</sup>	3/0-500 <sup>(a)</sup>
		2	XL 175 380 YD 175	#14-2/0 #4-500 #14-2/0	#14-2/0 #4-500	250	#6-350	#6-350	225 250	#6-350	#6-350	225 250	#6-350	#6-350
	575	1	380	#4-500	#4-500	250	#6-350	#6-350	300	3/0-500 <sup>(a)</sup>	3/0-500 <sup>(a)</sup>	N/A	N/A	N/A
		2	175	#14-2/0	#14-2/0	100 250	#10-1/0 #6-350	#10-1/0 #6-350	175 200	#6-350	#6-350	N/A	N/A	N/A
250	1	760	N/A	#4-500 <sup>(a)</sup>	700	N/A	#1-500 <sup>(b)</sup>	800	N/A	#1-500 <sup>(b)</sup>	800	N/A	#1-500 <sup>(b)</sup>	
		380	N/A	#4-500	400	N/A	3/0-500 <sup>(a)</sup>	600	N/A	3/0-500 <sup>(a)</sup>	600	N/A	3/0-500 <sup>(a)</sup>	
	230	1	760	N/A	#4-500 <sup>(a)</sup>	600	N/A	3/0-500 <sup>(b)</sup>	800	N/A	#1-500 <sup>(b)</sup>	800	N/A	#1-500 <sup>(a)</sup>
		2	380	N/A	#4-500	400	N/A	3/0-500 <sup>(a)</sup>	500	N/A	3/0-500 <sup>(a)</sup>	500	N/A	3/0-500 <sup>(a)</sup>
	380	1	380	#4-500	#4-500	400	3/0-500 <sup>(a)</sup>	3/0-500 <sup>(a)</sup>	450	3/0-500 <sup>(a)</sup>	3/0-500 <sup>(a)</sup>	450	3/0-500 <sup>(a)</sup>	3/0-500 <sup>(a)</sup>
		2	380	#4-500	#4-500	250	#6-350	#6-350	300	3/0-500 <sup>(a)</sup>	3/0-500 <sup>(a)</sup>	300	3/0-500 <sup>(a)</sup>	3/0-500 <sup>(a)</sup>
	460	1	380	#4-500	#4-500	400	3/0-500 <sup>(a)</sup>	3/0-500 <sup>(a)</sup>	400	3/0-500 <sup>(a)</sup>	3/0-500 <sup>(a)</sup>	400	3/0-500 <sup>(a)</sup>	3/0-500 <sup>(a)</sup>
		2	XL 380 YD 175	#4-500	#14-2/0	250	#6-350	#6-350	250	#6-350	#6-350	250	#6-350	#6-350
	575	1	380	#4-500	#4-500	250	#6-350	#6-350	300	3/0-500 <sup>(a)</sup>	3/0-500 <sup>(a)</sup>	N/A	N/A	N/A
		2	175	#14-2/0	#14-2/0	250	#6-350	#6-350	200	#6-350	#6-350	N/A	N/A	N/A

**Notes:**

1. Optional non-fused disconnect and circuit breaker.
2. Copper wire only, based on nameplate minimum circuit ampacity (MCA).
3. Standard condensing temperature option refers to entering condenser water temperatures 95°F (35°C) and below.
4. Circuit two information is the same as circuit one unless listed on a separate line below circuit one values.
5. XL - across-the-line starter and YD - wye-delta starter.

(a) Will accept 2 conduits per phase in this size.  
 (b) Will accept 3 conduits per phase in this size.

## Installation - Electrical

**Table 81. Customer Wire Selection - RTWD - 60 Hz - premium efficiency - standard condensing temperature**

		Wire Selection													
Rated Size	# Voltage Conn	Main Terminal Block			Disconnect			Circuit Breaker			Hi-Fault Panel Ckt Brkr				
		Size Amp	Wire Range XL YD		Size Amp	Wire Range XL YD		Size Amp	Wire Range XL YD		Size Amp	Wire Range XL YD			
200	1	760	N/A	#4-500 <sup>(a)</sup>	600	N/A	3/0- #500 <sup>(a)</sup>	600	N/A	3/0-500 <sup>(a)</sup>	600	N/A	3/0-500 <sup>(a)</sup>		
	2	380	N/A	#4-500	250	N/A	#6-350	350 400	N/A	3/0-500 <sup>(a)</sup>	350 400	N/A	3/0-500 <sup>(a)</sup>		
230	1	380	N/A	#4-500	400	N/A	3/0- #500 <sup>(a)</sup>	500	N/A	3/0-500 <sup>(a)</sup>	500	N/A	3/0-500 <sup>(a)</sup>		
	2	380	N/A	#4-500	250	N/A	#6-350	300 350	N/A	3/0-500 <sup>(a)</sup>	300 350	N/A	3/0-500 <sup>(a)</sup>		
150	380	1	380	#4-500	#4-500	250	#6-350	#6-350	300	3/0-500 <sup>(a)</sup>	3/0-500 <sup>(a)</sup>	300	3/0-500 <sup>(a)</sup>	3/0-500 <sup>(a)</sup>	
	2	175	#14-2/0	#14-2/0	250	#6-350	#6-350	175 225	#6-350	#6-350	175 225	#6-350	#6-350		
460	1	380	#4-500	#4-500	250	#6-350	#6-350	250	#6-350	#6-350	250	#6-350	#6-350		
	2	175	#14-2/0	#14-2/0	100	#10-1/0	#10-1/0	150 175	#6-350	#6-350	150 175	#6-350	#6-350		
575	1	175	#14-2/0	#14-2/0	250	#6-350	#6-350	200	#6-350	#6-350	N/A	N/A	N/A		
	2	175	#14-2/0	#14-2/0	100	#10-1/0	#10-1/0	125 150	#6-350	#6-350	N/A	N/A	N/A		
200	1	760	N/A	#4-500 <sup>(a)</sup>	600	N/A	3/0-500 <sup>(a)</sup>	600	N/A	3/0-500 <sup>(a)</sup>	600	N/A	3/0-500 <sup>(a)</sup>		
	2	380	N/A	#4-500	250	N/A	#6-350	400	N/A	3/0-500 <sup>(a)</sup>	400	N/A	3/0-500 <sup>(a)</sup>		
230	1	760	N/A	#4-500 <sup>(a)</sup>	400	N/A	3/0-500 <sup>(a)</sup>	500	N/A	3/0-500 <sup>(a)</sup>	500	N/A	3/0-500 <sup>(a)</sup>		
	2	380	N/A	#4-500	250	N/A	#6-350	350	N/A	3/0-500 <sup>(a)</sup>	350	N/A	3/0-500 <sup>(a)</sup>		
160	380	1	380	#4-500	#4-500	250	#6-350	#6-350	300	3/0-500 <sup>(a)</sup>	3/0-500 <sup>(a)</sup>	300	3/0-500 <sup>(a)</sup>	3/0-500 <sup>(a)</sup>	
	2	175	#14-2/0	#14-2/0	250	#6-350	#6-350	225	#6-350	#6-350	225	#6-350	#6-350		
460	1	380	#4-500	#4-500	250	#6-350	#6-350	250	3/0-500 <sup>(a)</sup>	3/0-500 <sup>(a)</sup>	250	3/0-500 <sup>(a)</sup>	3/0-500 <sup>(a)</sup>		
	2	175	#14-2/0	#14-2/0	100	#10-1/0	#10-1/0	175	#6-350	#6-350	175	#6-350	#6-350		
575	1	175	#14-2/0	#14-2/0	250	#6-350	#6-350	200	#6-350	#6-350	N/A	N/A	N/A		
	2	175	#14-2/0	#14-2/0	100	#10-1/0	#10-1/0	150	#6-350	#6-350	N/A	N/A	N/A		
200	1	760	N/A	#4-500 <sup>(a)</sup>	600	N/A	3/0-500 <sup>(a)</sup>	700	N/A	#1-500 <sup>(b)</sup>	700	N/A	#1-500 <sup>(b)</sup>		
	2	380	N/A	#4-500	250 400	N/A	#6-350 3/0-500 <sup>(a)</sup>	400 500	N/A	3/0-500 <sup>(a)</sup>	400 500	N/A	3/0-500 <sup>(a)</sup>		
230	1	760	N/A	#4-500 <sup>(a)</sup>	600	N/A	3/0-500 <sup>(a)</sup>	600	N/A	3/0-500 <sup>(a)</sup>	600	N/A	3/0-500 <sup>(a)</sup>		
	2	380	N/A	#4-500	250	N/A	#6-350	350 400	N/A	3/0-500 <sup>(a)</sup>	350 400	N/A	3/0-500 <sup>(a)</sup>		
180	380	1	380	#4-500	#4-500	400	3/0-500 <sup>(a)</sup>	3/0-500 <sup>(a)</sup>	350	3/0-500 <sup>(a)</sup>	3/0-500 <sup>(a)</sup>	350	3/0-500 <sup>(a)</sup>	3/0-500 <sup>(a)</sup>	
	2	XL 175/ 380 YD 175	#14-2/0 #4-500	#14-2/0	250	#6-350	#6-350	225 250	#6-350	#6-350	225 250	#6-350	#6-350		
460	1	380	#4-500	#4-500	250	#6-350	#6-350	300	3/0-500 <sup>(a)</sup>	3/0-500 <sup>(a)</sup>	300	3/0-500 <sup>(a)</sup>	3/0-500 <sup>(a)</sup>		
	2	175	#14-2/0	#14-2/0	100 250	#10-1/0 #6-350	#10-1/0 #6-350	175 225	#6-350	#6-350	175 225	#6-350	#6-350		
575	1	175	#14-2/0	#14-2/0	250	#6-350	#6-350	250	#6-350	#6-350	N/A	N/A	N/A		
	2	175	#14-2/0	#14-2/0	100	#10-1/0	#10-1/0	150 175	#6-350	#6-350	N/A	N/A	N/A		



## Installation - Electrical

**Table 81. Customer Wire Selection - RTWD - 60 Hz - premium efficiency - standard condensing temperature (continued)**

Rated Size	# Voltage Conn	Wire Selection											
		Main Terminal Block			Disconnect			Circuit Breaker			Hi-Fault Panel Ckt Brkr		
		Size Amp	Wire Range XL YD		Size Amp	Wire Range XL YD		Size Amp	Wire Range XL YD		Size Amp	Wire Range XL YD	
200	1	760	N/A	#4-500 <sup>(a)</sup>	600	N/A	3/0-500 <sup>(a)</sup>	700	N/A	#1-500 <sup>(b)</sup>	700	N/A	#1-500 <sup>(b)</sup>
	2	380	N/A	#4-500	400	N/A	3/0-500 <sup>(a)</sup>	500	N/A	3/0-500 <sup>(a)</sup>	500	N/A	3/0-500 <sup>(a)</sup>
230	1	760	N/A	#4-500 <sup>(a)</sup>	600	N/A	3/0-500 <sup>(a)</sup>	600	N/A	3/0-500 <sup>(a)</sup>	600	N/A	3/0-500 <sup>(a)</sup>
	2	380	N/A	#4-500	250	N/A	#6-350	400	N/A	3/0-500 <sup>(a)</sup>	400	N/A	3/0-500 <sup>(a)</sup>
200	1	380	#4-500	#4-500	400	3/0-500 <sup>(a)</sup>	3/0-500 <sup>(a)</sup>	350	3/0-500 <sup>(a)</sup>	3/0-500 <sup>(a)</sup>	350	3/0-500 <sup>(a)</sup>	3/0-500 <sup>(a)</sup>
	2	XL 380 YD 175	#4-500	#14-2/0	250	#6-350	#6-350	250	#6-350	#6-350	250	#6-350	#6-350
460	1	380	#4-500	#4-500	250	#6-350	#6-350	300	3/0-500 <sup>(a)</sup>	3/0-500 <sup>(a)</sup>	300	3/0-500 <sup>(a)</sup>	3/0-500 <sup>(a)</sup>
	2	175	#14-2/0	#14-2/0	250	#6-350	#6-350	225	#6-350	#6-350	225	#6-350	#6-350
575	1	380	#4-500	#4-500	250	#6-350	#6-350	250	3/0-500 <sup>(a)</sup>	3/0-500 <sup>(a)</sup>	N/A	N/A	N/A
	2	175	#14-2/0	#14-2/0	100	#10-1/0	#10-1/0	175	#6-350	#6-350	N/A	N/A	N/A

**Notes:**

1. Optional non-fused disconnect and circuit breaker.
2. Copper wire only, based on nameplate minimum circuit ampacity (MCA).
3. Standard condensing temperature option refers to entering condenser water temperatures 95°F (35°C) and below.
4. Circuit two information is the same as circuit one unless listed on a separate line below circuit one values.
5. XL - across-the-line starter and YD - wye-delta starter.

(a) Will accept 2 conduits per phase in this size.  
 (b) Will accept 3 conduits per phase in this size.

**Table 82. Customer Wire Selection - RTWD - 60 Hz - high efficiency - high condensing temperature**

Rated Size	# Voltage Conn	Wire Selection											
		Main Terminal Block			Disconnect			Circuit Breaker			Hi-Fault Panel Ckt Brkr		
		Size Amp	Wire Range XL YD		Size Amp	Wire Range XL YD		Size Amp	Wire Range XL YD		Size Amp	Wire Range XL YD	
200	1	380	N/A	#4-500	400	N/A	3/0-500 <sup>(a)</sup>	350	N/A	3/0-500 <sup>(a)</sup>	350	N/A	3/0-500 <sup>(a)</sup>
	2	175	N/A	#14-2/0	250	N/A	#6-350	250	N/A	#6-350	250	N/A	#6-350
230	1	380	N/A	#4-500	250	N/A	#6-350	300	N/A	3/0-500 <sup>(a)</sup>	300	N/A	3/0-500 <sup>(a)</sup>
	2	175	N/A	#14-2/0	250	N/A	#6-350	225	N/A	#6-350	225	N/A	#6-350
80	1	380	#4-500	#4-500	250	#6-350	#6-350	200	#6-350	#6-350	200	#6-350	#6-350
	2	175	#14-2/0	#14-2/0	100	#10-1/0	#10-1/0	125	#6-350	#6-350	125	#6-350	#6-350
460	1	380	#4-500	#4-500	250	#6-350	#6-350	N/A	N/A	N/A	N/A	N/A	N/A
	2	175	#14-2/0	#14-2/0	100	#10-1/0	#10-1/0	110	#6-350	#6-350	110	#6-350	#6-350
575	1	380	#4-500	#4-500	100	#10-1/0	#10-1/0	125	#6-350	#6-350	N/A	N/A	N/A
	2	175	#14-2/0	#14-2/0	100	#10-1/0	#10-1/0	90	#6-350	#6-350	N/A	N/A	N/A
200	1	380	N/A	#4-500	400	N/A	3/0-500 <sup>(a)</sup>	450	N/A	3/0-500 <sup>(a)</sup>	450	N/A	3/0-500 <sup>(a)</sup>
	2	380 175	N/A	#4-500 #14-2/0	250	N/A	#6-350	300	N/A	3/0-500 <sup>(a)</sup>	300	N/A	3/0-500 <sup>(a)</sup>
230	1	380	N/A	#4-500	400	N/A	3/0-500 <sup>(a)</sup>	400	N/A	3/0-500 <sup>(a)</sup>	400	N/A	3/0-500 <sup>(a)</sup>
	2	175	N/A	#14-2/0	250	N/A	#6-350	250	N/A	#6-350	250	N/A	#6-350
90	1	380	#4-500	#4-500	250	#6-350	#6-350	225	#6-350	#6-350	225	#6-350	#6-350
	2	175	#14-2/0	#14-2/0	100	#10-1/0	#10-1/0	150	#6-350	#6-350	150	#6-350	#6-350
460	1	380	#4-500	#4-500	250	#6-350	#6-350	200	#6-350	#6-350	200	#6-350	#6-350
	2	175	#14-2/0	#14-2/0	100	#10-1/0	#10-1/0	125	#6-350	#6-350	125	#6-350	#6-350
575	1	380	#4-500	#4-500	250	#6-350	#6-350	150	#6-350	#6-350	N/A	N/A	N/A
	2	175	#14-2/0	#14-2/0	100	#10-1/0	#10-1/0	110	#6-350	#6-350	N/A	N/A	N/A

## Installation - Electrical

**Table 82. Customer Wire Selection - RTWD - 60 Hz - high efficiency - high condensing temperature (continued)**

Rated # Size Voltage Conn		Wire Selection													
		Main Terminal Block			Disconnect			Circuit Breaker			Hi-Fault Panel Ckt Brkr				
		Size Amp	Wire Range XL YD	Size Amp	Wire Range XL YD	Size Amp	Wire Range XL YD	Size Amp	Wire Range XL YD	Size Amp	Wire Range XL YD				
100	200	1	380	N/A	#4-500	400	N/A	3/0-500 <sup>(a)</sup>	500	N/A	3/0-500 <sup>(a)</sup>	500	N/A	3/0-500 <sup>(a)</sup>	
		2	380	N/A	#4-500	250	N/A	#6-350	300 350	N/A	3/0-500 <sup>(a)</sup>	300 350	N/A	3/0-500 <sup>(a)</sup>	
	230	1	380	N/A	#4-500	400	N/A	3/0-500 <sup>(a)</sup>	450	N/A	3/0-500 <sup>(a)</sup>	450	N/A	3/0-500 <sup>(a)</sup>	
		2	175 380	N/A	#14-2/0 #4-500	250	N/A	#6-350	250 300	N/A	#6-350 3/0-500 <sup>(a)</sup>	250 300	N/A	#6-350 3/0-500 <sup>(a)</sup>	
	380	1	380	#4-500	#4-500	250	#6-350	#6-350	250	3/0-500 <sup>(a)</sup>	3/0-500 <sup>(a)</sup>	250	3/0-500 <sup>(a)</sup>	3/0-500 <sup>(a)</sup>	
		2	175	#14-2/0	#14-2/0	100 250	#10-1/0 #6-350	#10-1/0 #6-350	150 200	#6-350	#6-350	150 200	#6-350	#6-350	
	460	1	380	#4-500	#4-500	250	#6-350	#6-350	225	#6-350	#6-350	225	#6-350	#6-350	
		2	175	#14-2/0	#14-2/0	100	#10-1/0	#10-1/0	125 150	#6-350	#6-350	125 150	#6-350	#6-350	
	575	1	380	#4-500	#4-500	250	#6-350	#6-350	175	#6-350	#6-350	N/A	N/A	N/A	
		2	175	#14-2/0	#14-2/0	100	#10-1/0	#10-1/0	110 125	#6-350	#6-350	N/A	N/A	N/A	
	110	200	1	760	N/A	#4-500 <sup>(a)</sup>	600	N/A	3/0-500 <sup>(a)</sup>	500	N/A	3/0-500 <sup>(a)</sup>	500	N/A	3/0-500 <sup>(a)</sup>
			2	380	N/A	#4-500	250	N/A	#6-350	400 350	N/A	3/0-500 <sup>(a)</sup>	400 350	N/A	3/0-500 <sup>(a)</sup>
230		1	380	N/A	#4-500	400	N/A	3/0-500 <sup>(a)</sup>	500	N/A	3/0-500 <sup>(a)</sup>	500	N/A	3/0-500 <sup>(a)</sup>	
		2	380	N/A	#4-500	250	N/A	#6-350	300	N/A	3/0-500 <sup>(a)</sup>	300	N/A	3/0-500 <sup>(a)</sup>	
380		1	380	#4-500	#4-500	250	#6-350	#6-350	300	3/0-500 <sup>(a)</sup>	3/0-500 <sup>(a)</sup>	300	3/0-500 <sup>(a)</sup>	3/0-500 <sup>(a)</sup>	
		2	175	#14-2/0	#14-2/0	250	#6-350	#6-350	200	#6-350	#6-350	200	#6-350	#6-350	
460		1	380	#4-500	#4-500	250	#6-350	#6-350	250	#6-350	#6-350	250	#6-350	#6-350	
		2	175	#14-2/0	#14-2/0	100	#10-1/0	#10-1/0	175 150	#6-350	#6-350	175 150	#6-350	#6-350	
575		1	380	#4-500	#4-500	250	#6-350	#6-350	N/A	N/A	N/A	N/A	N/A	N/A	
		2	175	#14-2/0	#14-2/0	100	#10-1/0	#10-1/0	125	#6-350	#6-350	N/A	N/A	N/A	
120		200	1	760	N/A	#4-500 <sup>(a)</sup>	600	N/A	3/0-500 <sup>(a)</sup>	600	N/A	3/0-500 <sup>(a)</sup>	600	N/A	3/0-500 <sup>(a)</sup>
			2	380	N/A	#4-500	250	N/A	#6-350	400 450	N/A	3/0-500 <sup>(a)</sup>	400 450	N/A	3/0-500 <sup>(a)</sup>
	230	1	760	N/A	#4-500 <sup>(a)</sup>	600	N/A	3/0-500 <sup>(a)</sup>	500	N/A	3/0-500 <sup>(a)</sup>	500	N/A	3/0-500 <sup>(a)</sup>	
		2	380	N/A	#4-500	250	N/A	#6-350	300 400	N/A	3/0-500 <sup>(a)</sup>	300 400	N/A	3/0-500 <sup>(a)</sup>	
	380	1	380	#4-500	#4-500	250	#6-350	#6-350	300	3/0-500 <sup>(a)</sup>	3/0-500 <sup>(a)</sup>	300	3/0-500 <sup>(a)</sup>	3/0-500 <sup>(a)</sup>	
		2	175	#14-2/0	#14-2/0	250	#6-350	#6-350	200 225	#6-350	#6-350	200 225	#6-350	#6-350	
	460	1	380	#4-500	#4-500	250	#6-350	#6-350	250	3/0-500 <sup>(a)</sup>	3/0-500 <sup>(a)</sup>	250	3/0-500 <sup>(a)</sup>	3/0-500 <sup>(a)</sup>	
		2	175	#14-2/0	#14-2/0	100 250	#10-1/0 #6-350	#10-1/0 #6-350	175 200	#6-350	#6-350	175 200	#6-350	#6-350	
	575	1	380	#4-500	#4-500	250	#6-350	#6-350	200	3/0-500 <sup>(a)</sup>	3/0-500 <sup>(a)</sup>	N/A	N/A	N/A	
		2	175	#14-2/0	#14-2/0	100	#10-1/0	#10-1/0	125 150	#6-350	#6-350	N/A	N/A	N/A	
	130	200	1	N/A	N/A	N/A	N/A	N/A	N/A	N/A	N/A	N/A	N/A	N/A	N/A
			2	380	N/A	#4-500	250	N/A	#6-350	450	N/A	3/0-500 <sup>(a)</sup>	450	N/A	3/0-500 <sup>(a)</sup>
230		1	760	N/A	#4-500 <sup>(a)</sup>	600	N/A	3/0-500 <sup>(a)</sup>	500	N/A	3/0-500 <sup>(a)</sup>	500	N/A	3/0-500 <sup>(a)</sup>	
		2	380	N/A	#4-500	250	N/A	#6-350	400	N/A	3/0-500 <sup>(a)</sup>	400	N/A	3/0-500 <sup>(a)</sup>	
380		1	380	#4-500	#4-500	400	3/0-500 <sup>(a)</sup>	3/0-500 <sup>(a)</sup>	350	3/0-500 <sup>(a)</sup>	3/0-500 <sup>(a)</sup>	350	3/0-500 <sup>(a)</sup>	3/0-500 <sup>(a)</sup>	
		2	175	#14-2/0	#14-2/0	250	#6-350	#6-350	225	#6-350	#6-350	225	#6-350	#6-350	
460		1	380	#4-500	#4-500	250	#6-350	#6-350	250	3/0-500 <sup>(a)</sup>	3/0-500 <sup>(a)</sup>	250	3/0-500 <sup>(a)</sup>	3/0-500 <sup>(a)</sup>	
		2	175	#14-2/0	#14-2/0	250	#6-350	#6-350	200	#6-350	#6-350	200	#6-350	#6-350	
575		1	380	#4-500	#4-500	250	#6-350	#6-350	225	#6-350	#6-350	N/A	N/A	N/A	
		2	175	#14-2/0	#14-2/0	100	#10-1/0	#10-1/0	150	#6-350	#6-350	N/A	N/A	N/A	



## Installation - Electrical

**Table 82. Customer Wire Selection - RTWD - 60 Hz - high efficiency - high condensing temperature (continued)**

Rated Size	# Voltage Conn	Wire Selection												
		Main Terminal Block			Disconnect			Circuit Breaker			Hi-Fault Panel Ckt Brkr			
		Size Amp	Wire Range XL YD		Size Amp	Wire Range XL YD		Size Amp	Wire Range XL YD		Size Amp	Wire Range XL YD		
200	1	760	N/A	#4-500 <sup>(a)</sup>	600	N/A	3/0-500 <sup>(a)</sup>	700	N/A	#1-500 <sup>(b)</sup>	700	N/A	#1-500 <sup>(b)</sup>	
	2	380	N/A	#4-500	250 400	N/A	#6-350 3/0-500 <sup>(a)</sup>	450 500	N/A	3/0-500 <sup>(a)</sup>	450 500	N/A	3/0-500 <sup>(a)</sup>	
230	1	760	N/A	#4-500 <sup>(a)</sup>	600	N/A	3/0-500 <sup>(a)</sup>	600	N/A	3/0-500 <sup>(a)</sup>	600	N/A	3/0-500 <sup>(a)</sup>	
	2	380	N/A	#4-500	250 400	N/A	#6-350 3/0-500 <sup>(a)</sup>	400 450	N/A	3/0-500 <sup>(a)</sup>	400 450	N/A	3/0-500 <sup>(a)</sup>	
150	380	1	380	#4-500	#4-500	400	3/0-500 <sup>(a)</sup>	3/0-500 <sup>(a)</sup>	350	3/0-500 <sup>(a)</sup>	3/0-500 <sup>(a)</sup>	350	3/0-500 <sup>(a)</sup>	3/0-500 <sup>(a)</sup>
	2	XL 175/ 380 YD 175	#14-2/0 #4-500	#14-2/0	250	#6-350	#6-350	225 250	#6-350	#6-350	225 250	#6-350	#6-350	
460	1	380	#4-500	#4-500	250	#6-350	#6-350	300	3/0-500 <sup>(a)</sup>	3/0-500 <sup>(a)</sup>	300	3/0-500 <sup>(a)</sup>	3/0-500 <sup>(a)</sup>	
	2	175	#14-2/0	#14-2/0	250	#6-350	#6-350	200 225	#6-350	#6-350	200 225	#6-350	#6-350	
575	1	380	#4-500	#4-500	250	#6-350	#6-350	200	#6-350	#6-350	N/A	N/A	N/A	
	2	175	#14-2/0	#14-2/0	100 250	#10-1/0 #6-350	#10-1/0 #6-350	150 175	#6-350	#6-350	N/A	N/A	N/A	
200	1	760	N/A	#4-500 <sup>(a)</sup>	600	N/A	3/0-500 <sup>(a)</sup>	700	N/A	#1-500 <sup>(b)</sup>	700	N/A	#1-500 <sup>(b)</sup>	
	2	380	N/A	#4-500	400	N/A	3/0-500 <sup>(a)</sup>	500	N/A	3/0-500 <sup>(a)</sup>	500	N/A	3/0-500 <sup>(a)</sup>	
230	1	760	N/A	#4-500 <sup>(a)</sup>	600	N/A	3/0-500 <sup>(a)</sup>	600	N/A	3/0-500 <sup>(a)</sup>	600	N/A	3/0-500 <sup>(a)</sup>	
	2	380	N/A	#4-500	400	N/A	3/0-500 <sup>(a)</sup>	450	N/A	3/0-500 <sup>(a)</sup>	450	N/A	3/0-500 <sup>(a)</sup>	
160	380	1	380	#4-500	#4-500	400	3/0-500 <sup>(a)</sup>	3/0-500 <sup>(a)</sup>	400	3/0-500 <sup>(a)</sup>	3/0-500 <sup>(a)</sup>	400	3/0-500 <sup>(a)</sup>	3/0-500 <sup>(a)</sup>
	2	XL 380 YD 175	#4-500	#14-2/0	250	#6-350	#6-350	250	#6-350	#6-350	250	#6-350	#6-350	
460	1	380	#4-500	#4-500	400	3/0-500 <sup>(a)</sup>	3/0-500 <sup>(a)</sup>	300	3/0-500 <sup>(a)</sup>	3/0-500 <sup>(a)</sup>	300	3/0-500 <sup>(a)</sup>	3/0-500 <sup>(a)</sup>	
	2	175	#14-2/0	#14-2/0	250	#6-350	#6-350	225	#6-350	#6-350	225	#6-350	#6-350	
575	1	380	#4-500	#4-500	250	#6-350	#6-350	250	3/0-500 <sup>(a)</sup>	3/0-500 <sup>(a)</sup>	N/A	N/A	N/A	
	2	175	#14-2/0	#14-2/0	250	#6-350	#6-350	175	#6-350	#6-350	N/A	N/A	N/A	
200	1	760	N/A	#4-500 <sup>(a)</sup>	700	N/A	#1-500 <sup>(b)</sup>	800	N/A	#1-500 <sup>(b)</sup>	800	N/A	#1-500 <sup>(b)</sup>	
	2	380	N/A	#4-500	400	N/A	3/0-500 <sup>(a)</sup>	500 600	N/A	3/0-500 <sup>(a)</sup>	500 600	N/A	3/0-500 <sup>(a)</sup>	
230	1	760	N/A	#4-500 <sup>(a)</sup>	600	N/A	3/0-500 <sup>(a)</sup>	700	N/A	#1-500 <sup>(b)</sup>	700	N/A	#1-500 <sup>(b)</sup>	
	2	380	N/A	#4-500	400	N/A	3/0-500 <sup>(a)</sup>	450 500	N/A	3/0-500 <sup>(a)</sup>	450 500	N/A	3/0-500 <sup>(a)</sup>	
180	380	1	380	#4-500	#4-500	400	3/0-500 <sup>(a)</sup>	3/0-500 <sup>(a)</sup>	450	3/0-500	3/0-500 <sup>(a)</sup>	450	3/0-500	3/0-500 <sup>(a)</sup>
	2	XL 380 YD 175/ 380	#4-500	#14-2/0 #4-500	250	#6-350	#6-350	250 300	#6-350 3/0-500 <sup>(a)</sup>	#6-350 3/0-500 <sup>(a)</sup>	250 300	#6-350 3/0-500 <sup>(a)</sup>	#6-350 3/0-500 <sup>(a)</sup>	
460	1	380	#4-500	#4-500	400	3/0-500 <sup>(a)</sup>	3/0-500 <sup>(a)</sup>	350	3/0-500 <sup>(a)</sup>	3/0-500 <sup>(a)</sup>	350	3/0-500 <sup>(a)</sup>	3/0-500 <sup>(a)</sup>	
	2	XL 175/ 380 YD 175	#14-2/0 #4-500	#14-2/0	250	#6-350	#6-350	225 250	#6-350	#6-350	225 250	#6-350	#6-350	
575	1	380	#4-500	#4-500	250	#6-350	#6-350	300	3/0-500 <sup>(a)</sup>	3/0-500 <sup>(a)</sup>	N/A	N/A	N/A	
	2	175	#14-2/0	#14-2/0	250	#6-350	#6-350	175 200	#6-350	#6-350	N/A	N/A	N/A	

## Installation - Electrical

**Table 82. Customer Wire Selection - RTWD - 60 Hz - high efficiency - high condensing temperature (continued)**

		Wire Selection												
Rated Size	# Voltage Conn	Main Terminal Block			Disconnect			Circuit Breaker			Hi-Fault Panel Ckt Brkr			
		Size Amp	Wire Range XL	Wire Range YD	Size Amp	Wire Range XL	Wire Range YD	Size Amp	Wire Range XL	Wire Range YD	Size Amp	Wire Range XL	Wire Range YD	
200	1	760	N/A	#4-500 <sup>(a)</sup>	700	N/A	#1-500 <sup>(b)</sup>	800	N/A	#1-500 <sup>(b)</sup>	800	N/A	#1-500 <sup>(b)</sup>	
		380	N/A	#4-500	400	N/A	3/0-500 <sup>(a)</sup>	600	N/A	3/0-500 <sup>(a)</sup>	600	N/A	3/0-500 <sup>(a)</sup>	
	2	760	N/A	#4-500 <sup>(a)</sup>	600	N/A	3/0-500 <sup>(a)</sup>	700	N/A	#1-500 <sup>(b)</sup>	700	N/A	#1-500 <sup>(b)</sup>	
		380	N/A	#4-500	400	N/A	3/0-500 <sup>(a)</sup>	500	N/A	3/0-500 <sup>(a)</sup>	500	N/A	3/0-500 <sup>(a)</sup>	
	380	1	380	#4-500	#4-500	400	3/0-500 <sup>(a)</sup>	3/0-500 <sup>(a)</sup>	450	3/0-500 <sup>(a)</sup>	3/0-500 <sup>(a)</sup>	450	3/0-500 <sup>(a)</sup>	3/0-500 <sup>(a)</sup>
		2	380	#4-500	#4-500	250	#6-350	#6-350	300	3/0-500 <sup>(a)</sup>	3/0-500 <sup>(a)</sup>	300	3/0-500 <sup>(a)</sup>	3/0-500 <sup>(a)</sup>
	460	1	380	#4-500	#4-500	400	3/0-500 <sup>(a)</sup>	3/0-500 <sup>(a)</sup>	350	3/0-500 <sup>(a)</sup>	3/0-500 <sup>(a)</sup>	350	3/0-500 <sup>(a)</sup>	3/0-500 <sup>(a)</sup>
		2	XL 380 YD 175	#4-500	#14-2/0	250	#6-350	#6-350	250	#6-350	#6-350	250	#6-350	#6-350
	575	1	380	#4-500	#4-500	250	#6-350	#6-350	300	3/0-500 <sup>(a)</sup>	3/0-500 <sup>(a)</sup>	N/A	N/A	N/A
		2	175	#14-2/0	#14-2/0	250	#6-350	#6-350	200	#6-350	#6-350	N/A	N/A	N/A
220	1	760	N/A	#4-500 <sup>(a)</sup>	800	N/A	#1-500 <sup>(b)</sup>	1000	N/A	250-500 <sup>(c)</sup>	1000	N/A	250-500 <sup>(c)</sup>	
		380	N/A	#4-500	400	N/A	3/0-500 <sup>(a)</sup>	600	N/A	3/0-500 <sup>(a)</sup>	600	N/A	3/0-500 <sup>(a)</sup>	
	2	760	N/A	#4-500 <sup>(a)</sup>	600	N/A	3/0-500 <sup>(a)</sup>	700	N/A	#1-500 <sup>(b)</sup>	700	N/A	#1-500 <sup>(b)</sup>	
		380	N/A	#4-500	400	N/A	3/0-500 <sup>(a)</sup>	500	N/A	3/0-500 <sup>(a)</sup>	500	N/A	3/0-500 <sup>(a)</sup>	
	230	1	760	N/A	#4-500 <sup>(a)</sup>	700	N/A	#1-500 <sup>(b)</sup>	800	N/A	#1-500 <sup>(b)</sup>	800	N/A	#1-500 <sup>(b)</sup>
		2	380	N/A	#4-500	400	N/A	3/0-500 <sup>(a)</sup>	600	N/A	3/0-500 <sup>(a)</sup>	600	N/A	3/0-500 <sup>(a)</sup>
	380	1	380	#4-500	#4-500	400	3/0-500 <sup>(a)</sup>	3/0-500 <sup>(a)</sup>	500	3/0-500 <sup>(a)</sup>	3/0-500 <sup>(a)</sup>	500	3/0-500 <sup>(a)</sup>	3/0-500 <sup>(a)</sup>
		2	380	#4-500	#4-500	250	#6-350	#6-350	300	3/0-500 <sup>(a)</sup>	3/0-500 <sup>(a)</sup>	300	3/0-500 <sup>(a)</sup>	3/0-500 <sup>(a)</sup>
	460	1	380	#4-500	#4-500	400	3/0-500 <sup>(a)</sup>	3/0-500 <sup>(a)</sup>	400	3/0-500 <sup>(a)</sup>	3/0-500 <sup>(a)</sup>	400	3/0-500 <sup>(a)</sup>	3/0-500 <sup>(a)</sup>
		2	XL 380 YD 175/ 380	#4-500	#14-2/0 #4-500	250	#6-350	#6-350	250	#6-350	#6-350	250	#6-350	#6-350
575	1	380	#4-500	#4-500	400	3/0-500 <sup>(a)</sup>	3/0-500 <sup>(a)</sup>	350	3/0-500 <sup>(a)</sup>	3/0-500 <sup>(a)</sup>	N/A	N/A	N/A	
	2	XL 175/ 380 YD 175	#14-2/0 #4-500	#14-2/0	250	#6-350	#6-350	200 250	#6-350	#6-350	N/A	N/A	N/A	
250	1	760	N/A	#4-500 <sup>(a)</sup>	800	N/A	#1-500 <sup>(b)</sup>	1000	N/A	250-500 <sup>(c)</sup>	1000	N/A	250-500 <sup>(c)</sup>	
		760	N/A	#4-500 <sup>(a)</sup>	600	N/A	3/0-500 <sup>(a)</sup>	700	N/A	#1-500 <sup>(b)</sup>	700	N/A	#1-500 <sup>(b)</sup>	
	2	760	N/A	#4-500 <sup>(a)</sup>	800	N/A	#1-500 <sup>(b)</sup>	800	N/A	#1-500 <sup>(b)</sup>	800	N/A	#1-500 <sup>(b)</sup>	
		380	N/A	#4-500	400	N/A	3/0-500 <sup>(a)</sup>	600	N/A	3/0-500 <sup>(a)</sup>	600	N/A	3/0-500 <sup>(a)</sup>	
	380	1	760	#4-500 <sup>(a)</sup>	#4-500 <sup>(a)</sup>	600	3/0-500 <sup>(a)</sup>	3/0-500 <sup>(a)</sup>	500	3/0-500 <sup>(a)</sup>	3/0-500 <sup>(a)</sup>	500	3/0-500 <sup>(a)</sup>	3/0-500 <sup>(a)</sup>
		2	380	#4-500	#4-500	250	#6-350	#6-350	400	3/0-500 <sup>(a)</sup>	3/0-500 <sup>(a)</sup>	400	3/0-500 <sup>(a)</sup>	3/0-500 <sup>(a)</sup>
	460	1	380	#4-500	#4-500	400	3/0-500 <sup>(a)</sup>	3/0-500 <sup>(a)</sup>	450	3/0-500 <sup>(a)</sup>	3/0-500 <sup>(a)</sup>	450	3/0-500 <sup>(a)</sup>	3/0-500 <sup>(a)</sup>
		2	380	#4-500	#4-500	250	#6-350	#6-350	300	3/0-500 <sup>(a)</sup>	3/0-500 <sup>(a)</sup>	300	3/0-500 <sup>(a)</sup>	3/0-500 <sup>(a)</sup>
	575	1	380	#4-500	#4-500	400	3/0-500 <sup>(a)</sup>	3/0-500 <sup>(a)</sup>	350	3/0-500 <sup>(a)</sup>	3/0-500 <sup>(a)</sup>	N/A	N/A	N/A
		2	XL 380 YD 175	#4-500	#14-2/0	250	#6-350	#6-350	250	#6-350	#6-350	N/A	N/A	N/A

**Notes:**

1. Optional non-fused disconnect and circuit breaker.
2. Copper wire only, based on nameplate minimum circuit ampacity (MCA).
3. Standard condensing temperature option refers to entering condenser water temperatures 95°F (35°C) and below.
4. Circuit two information is the same as circuit one unless listed on a separate line below circuit one values.
5. XL - across-the-line starter and YD - wye-delta starter.

(a) Will accept 2 conduits per phase in this size.  
 (b) Will accept 3 conduits per phase in this size.  
 (c) Will accept 4 conduits per phase in this size.



## Installation - Electrical

**Table 83. Customer Wire Selection - RTWD - 60 Hz - premium efficiency - high condensing temperature**

		Wire Selection												
Rated Size	# Voltage Conn	Main Terminal Block			Disconnect			Circuit Breaker			Hi-Fault Panel Ckt Brkr			
		Size Amp	Wire Range XL	Wire Range YD	Size Amp	Wire Range XL	Wire Range YD	Size Amp	Wire Range XL	Wire Range YD	Size Amp	Wire Range XL	Wire Range YD	
200	1	760	N/A	#4-500 <sup>(a)</sup>	600	N/A	3/0-500 <sup>(a)</sup>	700	N/A	#1-500 <sup>(b)</sup>	700	N/A	#1-500 <sup>(c)</sup>	
	2	380	N/A	#4-500	250 400	N/A	#6-350 3/0-500 <sup>(a)</sup>	400 500	N/A	3/0-500 <sup>(a)</sup>	400 500	N/A	3/0-500 <sup>(a)</sup>	
230	1	760	N/A	#4-500 <sup>(a)</sup>	600	N/A	3/0-500 <sup>(a)</sup>	600	N/A	3/0-500 <sup>(a)</sup>	600	N/A	3/0-500 <sup>(a)</sup>	
	2	380	N/A	#4-500	250 400	N/A	#6-350 3/0-500 <sup>(a)</sup>	350 450	N/A	3/0-500 <sup>(a)</sup>	350 450	N/A	3/0-500 <sup>(a)</sup>	
150	380	1	380	#4-500	#4-500	400	3/0-500 <sup>(a)</sup>	3/0-500 <sup>(a)</sup>	350	3/0-500	3/0-500 <sup>(a)</sup>	350	3/0-500	3/0-500 <sup>(a)</sup>
	2	XL 175/ 380 YD 175	#4-500	#14-2/0 #4-500	#14-2/0	250	#6-350	#6-350	225 250	#6-350	#6-350	225 250	#6-350	#6-350
460	1	380	#4-500	#4-500	250	#6-350	#6-350	300	3/0-500 <sup>(a)</sup>	3/0-500 <sup>(a)</sup>	300	3/0-500 <sup>(a)</sup>	3/0-500 <sup>(a)</sup>	
	2	175	#14-2/0	#14-2/0	250	#6-350	#6-350	175 225	#6-350	#6-350	175 225	#6-350	#6-350	
575	1	380	#4-500	#4-500	250	#6-350	#6-350	250	#6-350	#6-350	N/A	N/A	N/A	
	2	175	#14-2/0	#14-2/0	100 250	#10-1/0 #6-350	#10-1/0 #6-350	150 175	#6-350	#6-350	N/A N/A	N/A N/A	N/A N/A	
200	1	760	N/A	#4-500 <sup>(a)</sup>	600	N/A	3/0-500 <sup>(a)</sup>	700	N/A	#1-500 <sup>(b)</sup>	700	N/A	#1-500 <sup>(b)</sup>	
	2	380	N/A	#4-500	400	N/A	3/0-500 <sup>(a)</sup>	500	N/A	3/0-500 <sup>(a)</sup>	500	N/A	3/0-500 <sup>(a)</sup>	
230	1	760	N/A	#4-500 <sup>(a)</sup>	600	N/A	3/0-500 <sup>(a)</sup>	600	N/A	3/0-500 <sup>(a)</sup>	600	N/A	3/0-500 <sup>(a)</sup>	
	2	380	N/A	#4-500	400	N/A	3/0-500 <sup>(a)</sup>	450	N/A	3/0-500 <sup>(a)</sup>	450	N/A	3/0-500 <sup>(a)</sup>	
160	380	1	380	#4-500	#4-500	400	3/0-500 <sup>(a)</sup>	3/0-500 <sup>(a)</sup>	400	3/0-500 <sup>(a)</sup>	3/0-500 <sup>(a)</sup>	400	3/0-500 <sup>(a)</sup>	3/0-500 <sup>(a)</sup>
	2	XL 380 YD 175	#4-500	#14-2/0	250	#6-350	#6-350	250	#6-350	#6-350	250	#6-350	#6-350	
460	1	380	#4-500	#4-500	400	3/0-500 <sup>(a)</sup>	3/0-500 <sup>(a)</sup>	300	3/0-500 <sup>(a)</sup>	3/0-500 <sup>(a)</sup>	300	3/0-500 <sup>(a)</sup>	3/0-500 <sup>(a)</sup>	
	2	175	#14-2/0	#14-2/0	250	#6-350	#6-350	225	#6-350	#6-350	225	#6-350	#6-350	
575	1	380	#4-500	#4-500	250	#6-350	#6-350	250	3/0-500 <sup>(a)</sup>	3/0-500 <sup>(a)</sup>	N/A	N/A	N/A	
	2	175	#14-2/0	#14-2/0	250	#6-350	#6-350	175	#6-350	#6-350	N/A	N/A	N/A	
200	1	760	N/A	#4-500 <sup>(a)</sup>	700	N/A	#1-500 <sup>(b)</sup>	800	N/A	#1-500 <sup>(b)</sup>	800	N/A	#1-500 <sup>(b)</sup>	
	2	380	N/A	#4-500	400	N/A	3/0-500 <sup>(a)</sup>	500 600	N/A	3/0-500 <sup>(a)</sup>	500 600	N/A	3/0-500 <sup>(a)</sup>	
230	1	760	N/A	#4-500 <sup>(a)</sup>	600	N/A	3/0-500 <sup>(a)</sup>	700	N/A	#1-500 <sup>(b)</sup>	700	N/A	#1-500 <sup>(b)</sup>	
	2	380	N/A	#4-500	400	N/A	3/0-500 <sup>(a)</sup>	450 500	N/A	3/0-500 <sup>(a)</sup>	450 500	N/A	3/0-500 <sup>(a)</sup>	
180	380	1	380	#4-500	#4-500	400	3/0-500 <sup>(a)</sup>	3/0-500 <sup>(a)</sup>	450	3/0-500	3/0-500 <sup>(a)</sup>	450	3/0-500	3/0-500 <sup>(a)</sup>
	2	XL 380 YD 175/ 380	#4-500	#14-2/0 #4-500	250	#6-350	#6-350	250 300	#6-350 3/0-500 <sup>(a)</sup>	#6-350 3/0-500 <sup>(a)</sup>	250 300	#6-350 3/0-500 <sup>(a)</sup>	#6-350 3/0-500 <sup>(a)</sup>	
460	1	380	#4-500	#4-500	400	3/0-500 <sup>(a)</sup>	3/0-500 <sup>(a)</sup>	350	3/0-500 <sup>(a)</sup>	3/0-500 <sup>(a)</sup>	350	3/0-500 <sup>(a)</sup>	3/0-500 <sup>(a)</sup>	
	2	XL 175/ 380 YD 175	#14-2/0 #4-500	#14-2/0	250	#6-350	#6-350	225 250	#6-350	#6-350	225 250	#6-350	#6-350	
575	1	380	#4-500	#4-500	250	#6-350	#6-350	300	3/0-500 <sup>(a)</sup>	3/0-500 <sup>(a)</sup>	N/A	N/A	N/A	
	2	175	#14-2/0	#14-2/0	250	#6-350	#6-350	175 200	#6-350	#6-350	N/A	N/A	N/A	



## Installation - Electrical

**Table 83. Customer Wire Selection - RTWD - 60 Hz - premium efficiency - high condensing temperature (continued)**

Rated Size	# Voltage Conn	Wire Selection												
		Main Terminal Block			Disconnect			Circuit Breaker			Hi-Fault Panel Ckt Brkr			
		Size Amp	Wire Range XL YD		Size Amp	Wire Range XL YD		Size Amp	Wire Range XL YD		Size Amp	Wire Range XL YD		
200	1	760	N/A	#4-500 <sup>(a)</sup>	700	N/A	#1-500 <sup>(b)</sup>	800	N/A	#1-500 <sup>(b)</sup>	800	N/A	#1-500 <sup>(b)</sup>	
		380	N/A	#4-500	400	N/A	3/0-500 <sup>(a)</sup>	600	N/A	3/0-500 <sup>(a)</sup>	600	N/A	3/0-500 <sup>(a)</sup>	
	230	1	760	N/A	#4-500 <sup>(a)</sup>	600	N/A	3/0-500 <sup>(a)</sup>	700	N/A	#1-500 <sup>(b)</sup>	700	N/A	#1-500 <sup>(b)</sup>
		2	380	N/A	#4-500	400	N/A	3/0-500 <sup>(a)</sup>	500	N/A	3/0-500 <sup>(a)</sup>	500	N/A	3/0-500 <sup>(a)</sup>
	380	1	380	#4-500	#4-500	400	3/0-500 <sup>(a)</sup>	3/0-500 <sup>(a)</sup>	450	3/0-500 <sup>(a)</sup>	3/0-500 <sup>(a)</sup>	450	3/0-500 <sup>(a)</sup>	3/0-500 <sup>(a)</sup>
		2	380	#4-500	#4-500	250	#6-350	#6-350	300	3/0-500 <sup>(a)</sup>	3/0-500 <sup>(a)</sup>	300	3/0-500 <sup>(a)</sup>	3/0-500 <sup>(a)</sup>
	460	1	380	#4-500	#4-500	400	3/0-500 <sup>(a)</sup>	3/0-500 <sup>(a)</sup>	350	3/0-500 <sup>(a)</sup>	3/0-500 <sup>(a)</sup>	350	3/0-500 <sup>(a)</sup>	3/0-500 <sup>(a)</sup>
		2	XL 380 YD 175	#4-500	#14-2/0	250	#6-350	#6-350	250	#6-350	#6-350	250	#6-350	#6-350
	575	1	380	#4-500	#4-500	250	#6-350	#6-350	300	3/0-500 <sup>(a)</sup>	3/0-500 <sup>(a)</sup>	N/A	N/A	N/A
		2	175	#14-2/0	#14-2/0	250	#6-350	#6-350	200	#6-350	#6-350	N/A	N/A	N/A

**Notes:**

- Optional non-fused disconnect and circuit breaker.
- Copper wire only, based on nameplate minimum circuit ampacity (MCA).
- Standard condensing temperature option refers to entering condenser water temperatures 95°F (35°C) and below.
- Circuit two information is the same as circuit one unless listed on a separate line below circuit one values.
- XL - across-the-line starter and YD - wye-delta starter.

- (a) Will accept 2 conduits per phase in this size.  
 (b) Will accept 3 conduits per phase in this size.  
 (c) Will accept 3 conduits per phase in this size.

**Table 84. Customer Wire Selection - RTUD - 60 Hz**

Rated Size	# Voltage Conn	Wire Selection												
		Main Terminal Block			Disconnect			Circuit Breaker			Hi-Fault Panel Ckt Brkr			
		Size Amp	Wire Range XL YD		Size Amp	Wire Range XL YD		Size Amp	Wire Range XL YD		Size Amp	Wire Range XL YD		
80	1	380	N/A	#4-500	400	N/A	3/0-500 <sup>(a)</sup>	400	N/A	3/0-500 <sup>(a)</sup>	400	N/A	3/0-500 <sup>(a)</sup>	
		175	N/A	#14-2/0	250	N/A	#6-350	250	N/A	#6-350	250	N/A	#6-350	
	230	1	380	N/A	#4-500	400	N/A	3/0-500 <sup>(a)</sup>	350	N/A	3/0-500 <sup>(a)</sup>	350	N/A	3/0-500 <sup>(a)</sup>
		2	175	N/A	#14-2/0	250	N/A	#6-350	250	N/A	#6-350	250	N/A	#6-350
	380	1	175	#14-2/0	#14-2/0	250	#6-350	#6-350	225	#6-350	#6-350	225	#6-350	#6-350
		2	175	#14-2/0	#14-2/0	100	#10-1/0	#10-1/0	150	#6-350	#6-350	150	#6-350	#6-350
	460	1	175	#14-2/0	#14-2/0	250	#6-350	#6-350	175	#6-350	#6-350	175	#6-350	#6-350
		2	175	#14-2/0	#14-2/0	100	#10-1/0	#10-1/0	125	#6-350	#6-350	125	#6-350	#6-350
	575	1	175	#14-2/0	#14-2/0	250	#6-350	#6-350	150	#6-350	#6-350	N/A	N/A	N/A
		2	175	#14-2/0	#14-2/0	100	#10-1/0	#10-1/0	100	#6-350	#6-350	N/A	N/A	N/A
	200	1	380	N/A	#4-500	400	N/A	3/0-500 <sup>(a)</sup>	500	N/A	3/0-500 <sup>(a)</sup>	500	N/A	3/0-500 <sup>(a)</sup>
		2	380	N/A	#4-500	250	N/A	#6-350	350/ 300	N/A	3/0-500 <sup>(a)</sup>	350/ 300	N/A	3/0-500 <sup>(a)</sup>
230	1	380	N/A	#4-500	400	N/A	3/0-500 <sup>(a)</sup>	400	N/A	3/0-500 <sup>(a)</sup>	400	N/A	3/0-500 <sup>(a)</sup>	
	2	175	N/A	#14-2/0	250	N/A	#6-350	250	N/A	#6-350	250	N/A	#6-350	
90	380	1	380	#4-500	#4-500	250	#6-350	#6-350	250	3/0-500 <sup>(a)</sup>	3/0-500 <sup>(a)</sup>	250	3/0-500 <sup>(a)</sup>	3/0-500 <sup>(a)</sup>
		2	175	#14-2/0	#14-2/0	250	#6-350	#6-350	175	#6-350	#6-350	175	#6-350	#6-350
460	1	175	#14-2/0	#14-2/0	250	#6-350	#6-350	200	#6-350	#6-350	200	#6-350	#6-350	
	2	175	#14-2/0	#14-2/0	100	#10-1/0	#10-1/0	150	#6-350	#6-350	150	#6-350	#6-350	
575	1	175	#14-2/0	#14-2/0	250	#6-350	#6-350	175	#6-350	#6-350	N/A	N/A	N/A	
	2	175	#14-2/0	#14-2/0	100	#10-1/0	#10-1/0	110	#6-350	#6-350	N/A	N/A	N/A	



## Installation - Electrical

**Table 84. Customer Wire Selection - RTUD - 60 Hz (continued)**

Rated Size	# Voltage Conn	Wire Selection												
		Main Terminal Block			Disconnect			Circuit Breaker			Hi-Fault Panel Ckt Brkr			
		Size Amp	Wire Range XL YD		Size Amp	Wire Range XL YD		Size Amp	Wire Range XL YD		Size Amp	Wire Range XL YD		
100	200	1	760	N/A	#4-500 <sup>(a)</sup>	600	N/A	3/0-500 <sup>(a)</sup>	500	N/A	3/0-500 <sup>(a)</sup>	500	N/A	3/0-500 <sup>(a)</sup>
		2	380	N/A	#4-500	250	N/A	#6-350	350/ 400	N/A	3/0-500 <sup>(a)</sup>	350/ 400	N/A	3/0-500 <sup>(a)</sup>
	230	1	380	N/A	#4-500	400	N/A	3/0-500 <sup>(a)</sup>	500	N/A	3/0-500 <sup>(a)</sup>	500	N/A	3/0-500 <sup>(a)</sup>
		2	175/ 380	N/A	#14-2/0 #4-500	250	N/A	#6-350	250/ 350	N/A	#6-350 3/0-500 <sup>(a)</sup>	250/ 350	N/A	#6-350 3/0-500 <sup>(a)</sup>
	380	1	380	#4-500	#4-500	250	#6-350	#6-350	300	3/0-500 <sup>(a)</sup>	3/0-500 <sup>(a)</sup>	300	3/0-500 <sup>(a)</sup>	3/0-500 <sup>(a)</sup>
		2	175	#14-2/0	#14-2/0	250	#6-350	#6-350	175/ 225	#6-350	#6-350	175/ 225	#6-350	#6-350
	460	1	175	#14-2/0	#14-2/0	250	#6-350	#6-350	250	#6-350	#6-350	250	#6-350	#6-350
		2	175	#14-2/0	#14-2/0	100/ 250	#10-1/0 #6-350	#10-1/0 #6-350	150/ 175	#6-350	#6-350	150/ 175	#6-350	#6-350
	575	1	175	#14-2/0	#14-2/0	250	#6-350	#6-350	200	#6-350	#6-350	N/A	N/A	N/A
		2	175	#14-2/0	#14-2/0	100	#10-1/0	#10-1/0	110/ 150	#6-350	#6-350	N/A	N/A	N/A
110	200	1	760	N/A	#4- (2)500 <sup>(a)</sup>	600	N/A	3/0- (2)500 <sup>(a)</sup>	600	N/A	3/0- (2)500 <sup>(a)</sup>	600	N/A	3/0- (2)500 <sup>(a)</sup>
		2	380	N/A	#4-500	250	N/A	#6-350	400	N/A	3/0- (2)500 <sup>(a)</sup>	400	N/A	3/0- (2)500 <sup>(a)</sup>
	230	1	380	N/A	#4-500	600	N/A	3/0- (2)500 <sup>(a)</sup>	500	N/A	3/0- (2)500 <sup>(a)</sup>	500	N/A	3/0- (2)500 <sup>(a)</sup>
		2	380	N/A	#4-500	250	N/A	#6-350	350	N/A	3/0- (2)500 <sup>(a)</sup>	350	N/A	3/0- (2)500 <sup>(a)</sup>
	380	1	380	#4-500	#4-500	400	3/0-(2)500	3/0- (2)500 <sup>(a)</sup>	300	3/0- (2)500	3/0- (2)500 <sup>(a)</sup>	300	3/0- (2)500	3/0- (2)500 <sup>(a)</sup>
		2	175	#14-2/0	#14-2/0	250	#6-350	#6-350	225	#6-350	#6-350	225	#6-350	#6-350
	460	1	380	#4-500	#4-500	250	#6-350	#6-350	250	3/0- (2)500	3/0- (2)500 <sup>(a)</sup>	250	3/0- (2)500	3/0- (2)500 <sup>(a)</sup>
		2	175	#14-2/0	#14-2/0	250	#6-350	#6-350	175	#6-350	#6-350	175	#6-350	#6-350
	575	1	175	#14-2/0	#14-2/0	250	#6-350	#6-350	200	#6-350	#6-350	N/A	N/A	N/A
		2	175	#14-2/0	#14-2/0	100	#10-1/0	#10-1/0	150	#6-350	#6-350	N/A	N/A	N/A
120	200	1	760	N/A	#4- (2)500 <sup>(a)</sup>	600	N/A	3/0- (2)500 <sup>(a)</sup>	600	N/A	3/0- (2)500 <sup>(a)</sup>	600	N/A	3/0- (2)500 <sup>(a)</sup>
		2	380	N/A	#4-500	250/ 400	N/A	#6-350 3/0- (2)500 <sup>(a)</sup>	400/ 450	N/A	3/0- (2)500 <sup>(a)</sup>	400/ 450	N/A	3/0- (2)500 <sup>(a)</sup>
	230	1	760	N/A	#4- (2)500 <sup>(a)</sup>	600	N/A	3/0- (2)500 <sup>(a)</sup>	600	N/A	3/0- (2)500 <sup>(a)</sup>	600	N/A	3/0- (2)500 <sup>(a)</sup>
		2	380	N/A	#4-500	250	N/A	#6-350	350/ 450	N/A	3/0- (2)500 <sup>(a)</sup>	350/ 450	N/A	3/0- (2)500 <sup>(a)</sup>
	380	1	380	#4-500	#4-500	400	3/0-(2)500	3/0- (2)500 <sup>(a)</sup>	350	3/0- (2)500	3/0- (2)500 <sup>(a)</sup>	350	3/0- (2)500	3/0- (2)500 <sup>(a)</sup>
		2	175	#14-2/0	#14-2/0	250	#6-350	#6-350	225/ 250	#6-350	#6-350	225/ 250	#6-350	#6-350
	460	1	380	#4-500	#4-500	250	#6-350	#6-350	300	3/0- (2)500 <sup>(a)</sup>	3/0- (2)500 <sup>(a)</sup>	300	3/0- (2)500 <sup>(a)</sup>	3/0- (2)500 <sup>(a)</sup>
		2	175	#14-2/0	#14-2/0	250	#6-350	#6-350	175/ 225	#6-350	#6-350	175/ 225	#6-350	#6-350
	575	1	175	#14-2/0	#14-2/0	250	#6-350	#6-350	225	#6-350	#6-350	N/A	N/A	N/A
		2	175	#14-2/0	#14-2/0	100	#10-1/0	#10-1/0	150/ 175	#6-350	#6-350	N/A	N/A	N/A

## Installation - Electrical

**Table 84. Customer Wire Selection - RTUD - 60 Hz (continued)**

Rated Size	# Voltage Conn	Wire Selection												
		Main Terminal Block			Disconnect			Circuit Breaker			Hi-Fault Panel Ckt Brkr			
		Size Amp	Wire Range XL YD		Size Amp	Wire Range XL YD		Size Amp	Wire Range XL YD		Size Amp	Wire Range XL YD		
130	200	1	760	N/A	#4-(2)500 <sup>(a)</sup>	600	N/A	3/0-(2)500 <sup>(a)</sup>	600	N/A	3/0-(2)500 <sup>(a)</sup>	600	N/A	3/0-(2)500 <sup>(a)</sup>
		2	380	N/A	#4-500	400	N/A	3/0-(2)500 <sup>(a)</sup>	450	N/A	3/0-(2)500 <sup>(a)</sup>	450	N/A	3/0-(2)500 <sup>(a)</sup>
	230	1	760	N/A	#4-(2)500 <sup>(a)</sup>	600	N/A	3/0-(2)500 <sup>(a)</sup>	600	N/A	3/0-(2)500 <sup>(a)</sup>	600	N/A	3/0-(2)500 <sup>(a)</sup>
		2	380	N/A	#4-500	250	N/A	#6-350	450	N/A	3/0-(2)500 <sup>(a)</sup>	450	N/A	3/0-(2)500 <sup>(a)</sup>
	380	1	380	#4-500	#4-500	400	3/0-(2)500 <sup>(a)</sup>	3/0-(2)500 <sup>(a)</sup>	350	3/0-(2)500	3/0-(2)500 <sup>(a)</sup>	350	3/0-(2)500	3/0-(2)500 <sup>(a)</sup>
		2	175	#14-2/0	#14-2/0	250	#6-350	#6-350	250	#6-350	#6-350	250	#6-350	#6-350
	460	1	380	#4-500	#4-500	250	#6-350	#6-350	300	3/0-(2)500 <sup>(a)</sup>	3/0-(2)500 <sup>(a)</sup>	300	3/0-(2)500 <sup>(a)</sup>	3/0-(2)500 <sup>(a)</sup>
		2	175	#14-2/0	#14-2/0	250	#6-350	#6-350	225	#6-350	#6-350	225	#6-350	#6-350
	575	1	380	#4-500	#4-500	250	#6-350	#6-350	250	3/0-(2)500 <sup>(a)</sup>	3/0-(2)500 <sup>(a)</sup>	N/A	N/A	N/A
		2	175	#14-2/0	#14-2/0	100	#10-1/0	#10-1/0	175	#6-350	#6-350	N/A	N/A	N/A
150	200	1	760	N/A	#4-500 <sup>(a)</sup>	700	N/A	#1-500 <sup>(b)</sup>	800	N/A	#1-500 <sup>(b)</sup>	800	N/A	#1-500 <sup>(b)</sup>
		2	380	N/A	#4-500	400	N/A	3/0-500 <sup>(a)</sup>	450/600	N/A	3/0-500 <sup>(a)</sup>	450/600	N/A	3/0-500 <sup>(a)</sup>
	230	1	760	N/A	#4-500 <sup>(a)</sup>	600	N/A	3/0-500 <sup>(a)</sup>	700	N/A	#1-500 <sup>(b)</sup>	700	N/A	#1-500 <sup>(b)</sup>
		2	380	N/A	#4-500	250/400	N/A	#6-350 3/0-500 <sup>(a)</sup>	700 450/500	N/A	#1-500 <sup>(b)</sup> 3/0-500 <sup>(a)</sup>	700 450/500	N/A	#1-500 <sup>(b)</sup> 3/0-500 <sup>(a)</sup>
	380	1	380	#4-500	#4-500	400	3/0-500 <sup>(a)</sup>	3/0-500 <sup>(a)</sup>	400	3/0-500 <sup>(a)</sup>	3/0-500 <sup>(a)</sup>	400	3/0-500 <sup>(a)</sup>	3/0-500 <sup>(a)</sup>
		2	175/380	#14-2/0 #4-500	#14-2/0 #4-500	250	#6-350	#6-350	250/300	#6-350 3/0-500 <sup>(a)</sup>	#6-350 3/0-500 <sup>(a)</sup>	250/300	#6-350 3/0-500 <sup>(a)</sup>	#6-350 3/0-500 <sup>(a)</sup>
	460	1	380	#4-500	#4-500	400	3/0-500 <sup>(a)</sup>	3/0-500 <sup>(a)</sup>	350	3/0-500 <sup>(a)</sup>	3/0-500 <sup>(a)</sup>	350	3/0-500 <sup>(a)</sup>	3/0-500 <sup>(a)</sup>
		2	175	#14-2/0	#14-2/0	250	#6-350	#6-350	225/250	#6-350	#6-350	225/250	#6-350	#6-350
	575	1	380	#4-500	#4-500	250	#6-350	#6-350	250	3/0-500 <sup>(a)</sup>	3/0-500 <sup>(a)</sup>	N/A	N/A	N/A
		2	175	#14-2/0	#14-2/0	100/250	#10-1/0 #6-350	#10-1/0 #6-350	175/200	#6-350	#6-350	N/A	N/A	N/A
160	200	1	760	N/A	#4-500 <sup>(a)</sup>	700	N/A	#1-500 <sup>(b)</sup>	800	N/A	#1-500 <sup>(b)</sup>	800	N/A	#1-500 <sup>(b)</sup>
		2	380	N/A	#4-500	400	N/A	3/0-500 <sup>(a)</sup>	600	N/A	3/0-500 <sup>(a)</sup>	600	N/A	3/0-500 <sup>(a)</sup>
	230	1	760	N/A	#4-500 <sup>(a)</sup>	600	N/A	3/0-500 <sup>(a)</sup>	700	N/A	#1-500 <sup>(b)</sup>	700	N/A	#1-500 <sup>(b)</sup>
		2	380	N/A	#4-500	400	N/A	3/0-500 <sup>(a)</sup>	500	N/A	3/0-500 <sup>(a)</sup>	500	N/A	3/0-500 <sup>(a)</sup>
	380	1	380	#4-500	#4-500	400	3/0-500 <sup>(a)</sup>	3/0-500 <sup>(a)</sup>	450	3/0-500 <sup>(a)</sup>	3/0-500 <sup>(a)</sup>	450	3/0-500 <sup>(a)</sup>	3/0-500 <sup>(a)</sup>
		2	380	#4-500	#4-500	250	#6-350	#6-350	300	3/0-500 <sup>(a)</sup>	3/0-500 <sup>(a)</sup>	300	3/0-500 <sup>(a)</sup>	3/0-500 <sup>(a)</sup>
	460	1	380	#4-500	#4-500	400	3/0-500 <sup>(a)</sup>	3/0-500 <sup>(a)</sup>	350	3/0-500 <sup>(a)</sup>	3/0-500 <sup>(a)</sup>	350	3/0-500 <sup>(a)</sup>	3/0-500 <sup>(a)</sup>
		2	175	#14-2/0	#14-2/0	250	#6-350	#6-350	250	#6-350	#6-350	250	#6-350	#6-350
	575	1	380	#4-500	#4-500	250	#6-350	#6-350	300	3/0-500 <sup>(a)</sup>	3/0-500 <sup>(a)</sup>	N/A	N/A	N/A
		2	175	#14-2/0	#14-2/0	250	#6-350	#6-350	200	#6-350	#6-350	N/A	N/A	N/A



## Installation - Electrical

**Table 84. Customer Wire Selection - RTUD - 60 Hz (continued)**

Rated Size	# Voltage Conn	Wire Selection													
		Main Terminal Block			Disconnect			Circuit Breaker			Hi-Fault Panel Ckt Brkr				
		Size Amp	Wire Range XL	Wire Range YD	Size Amp	Wire Range XL	Wire Range YD	Size Amp	Wire Range XL	Wire Range YD	Size Amp	Wire Range XL	Wire Range YD		
180	200	1	760	N/A	#4-500 <sup>(a)</sup>	800	N/A	#1-500 <sup>(b)</sup>	800	N/A	#1-500 <sup>(b)</sup>	800	N/A	#1-500 <sup>(b)</sup>	
		2	380/760	N/A	#4-500/ #4-500 <sup>(a)</sup>	400	N/A	3/0-500 <sup>(a)</sup>	600/700	N/A	3/0-500 <sup>(a)</sup> / #1-500 <sup>(b)</sup>	600/700	N/A	3/0-500 <sup>(a)</sup> / #1-500 <sup>(b)</sup>	
	230	1	760	N/A	#4-500 <sup>(a)</sup>	700	N/A	#1-500 <sup>(b)</sup>	800	N/A	#1-500 <sup>(b)</sup>	800	N/A	#1-500 <sup>(b)</sup>	
		2	380	N/A	#4-500	400	N/A	3/0-500 <sup>(a)</sup>	500/600	N/A	3/0-500 <sup>(a)</sup>	500/600	N/A	3/0-500 <sup>(a)</sup>	
	380	1	380	#4-500	#4-500	400	3/0-500 <sup>(a)</sup>	3/0-500 <sup>(a)</sup>	500	3/0-500 <sup>(a)</sup>	3/0-500 <sup>(a)</sup>	500	3/0-500 <sup>(a)</sup>	3/0-500 <sup>(a)</sup>	
		2	380	#4-500	#4-500	250	#6-350	#6-350	300/350	3/0-500 <sup>(a)</sup>	3/0-500 <sup>(a)</sup>	300/350	3/0-500 <sup>(a)</sup>	3/0-500 <sup>(a)</sup>	
	460	1	380	#4-500	#4-500	400	3/0-500 <sup>(a)</sup>	3/0-500 <sup>(a)</sup>	400	3/0-500 <sup>(a)</sup>	3/0-500 <sup>(a)</sup>	400	3/0-500 <sup>(a)</sup>	3/0-500 <sup>(a)</sup>	
		2	175	#14-2/0	#14-2/0	250	#6-350	#6-350	250	#6-350	#6-350	250	#6-350	#6-350	
	575	1	380	#4-500	#4-500	250	#6-350	#6-350	300	3/0-500 <sup>(a)</sup>	3/0-500 <sup>(a)</sup>	N/A	N/A	N/A	
		2	175	#14-2/0	#14-2/0	250	#6-350	#6-350	200/225	#6-350	#6-350	N/A	N/A	N/A	
	200	200	1	760	N/A	#4-500 <sup>(a)</sup>	800	N/A	#1-500 <sup>(b)</sup>	1000	N/A	250-500 <sup>(c)</sup>	1000	N/A	250-500 <sup>(d)</sup>
			2	760	N/A	#4-500 <sup>(a)</sup>	400	N/A	3/0-500 <sup>(a)</sup>	700	N/A	#1-500 <sup>(b)</sup>	700	N/A	#1-500 <sup>(b)</sup>
230		1	760	N/A	#4-500 <sup>(a)</sup>	700	N/A	#1-500 <sup>(b)</sup>	800	N/A	#1-500 <sup>(b)</sup>	800	N/A	#1-500 <sup>(b)</sup>	
		2	380	N/A	#4-500	400	N/A	3/0-500 <sup>(a)</sup>	600	N/A	3/0-500 <sup>(a)</sup>	600	N/A	3/0-500 <sup>(a)</sup>	
380		1	760	#4-500 <sup>(a)</sup>	#4-500 <sup>(a)</sup>	600	3/0-500 <sup>(a)</sup>	3/0-500 <sup>(a)</sup>	500	3/0-500 <sup>(a)</sup>	3/0-500 <sup>(a)</sup>	500	3/0-500 <sup>(a)</sup>	3/0-500 <sup>(a)</sup>	
		2	380	#4-500	#4-500	250	#6-350	#6-350	350	3/0-500 <sup>(a)</sup>	3/0-500 <sup>(a)</sup>	350	3/0-500 <sup>(a)</sup>	3/0-500 <sup>(a)</sup>	
460		1	380	#4-500	#4-500	400	3/0-500 <sup>(a)</sup>	3/0-500 <sup>(a)</sup>	400	3/0-500 <sup>(a)</sup>	3/0-500 <sup>(a)</sup>	400	3/0-500 <sup>(a)</sup>	3/0-500 <sup>(a)</sup>	
		2	175	#14-2/0	#14-2/0	250	#6-350	#6-350	250	#6-350	#6-350	250	#6-350	#6-350	
575		1	380	#4-500	#4-500	400	3/0-500 <sup>(a)</sup>	3/0-500 <sup>(a)</sup>	350	3/0-500 <sup>(a)</sup>	3/0-500 <sup>(a)</sup>	N/A	N/A	N/A	
		2	175	#14-2/0	#14-2/0	250	#6-350	#6-350	250/225	#6-350	#6-350	N/A	N/A	N/A	
220		200	1	760	N/A	#4-500 <sup>(a)</sup>	800	N/A	#1-500 <sup>(b)</sup>	1000	N/A	250-500 <sup>(c)</sup>	1000	N/A	250-500 <sup>(c)</sup>
			2	760	N/A	#4-500 <sup>(a)</sup>	400/600	N/A	3/0-500 <sup>(a)</sup>	700	N/A	#1-500 <sup>(b)</sup>	700	N/A	#1-500 <sup>(b)</sup>
	230	1	760	N/A	#4-500 <sup>(a)</sup>	800	N/A	#1-500 <sup>(b)</sup>	1000	N/A	250-500 <sup>(c)</sup>	1000	N/A	250-500 <sup>(c)</sup>	
		2	380/760	N/A	#4-500/ #4-500 <sup>(a)</sup>	400/600	N/A	3/0-500 <sup>(a)</sup>	600/700	N/A	3/0-500 <sup>(a)</sup> / #1-500 <sup>(b)</sup>	600/700	N/A	3/0-500 <sup>(a)</sup> / #1-500 <sup>(b)</sup>	
	380	1	760	#4-500 <sup>(a)</sup>	#4-500 <sup>(a)</sup>	600	3/0-500 <sup>(a)</sup>	3/0-500 <sup>(a)</sup>	600	3/0-500 <sup>(a)</sup>	3/0-500 <sup>(a)</sup>	600	3/0-500 <sup>(a)</sup>	3/0-500 <sup>(a)</sup>	
		2	380	#4-500	#4-500	250	#6-350	#6-350	350/450	3/0-500 <sup>(a)</sup>	3/0-500 <sup>(a)</sup>	350/450	3/0-500 <sup>(a)</sup>	3/0-500 <sup>(a)</sup>	
	460	1	380	#4-500	#4-500	400	3/0-500 <sup>(a)</sup>	3/0-500 <sup>(a)</sup>	500	3/0-500 <sup>(a)</sup>	3/0-500 <sup>(a)</sup>	500	3/0-500 <sup>(a)</sup>	3/0-500 <sup>(a)</sup>	
		2	175/380	#14-2/0/ #4-500	#14-2/0/ #4-500	250	#6-350	#6-350	250/350	#6-350/ 3/0-500 <sup>(a)</sup>	#6-350/ 3/0-500 <sup>(a)</sup>	250/350	#6-350/ 3/0-500 <sup>(a)</sup>	#6-350/ 3/0-500 <sup>(a)</sup>	
	575	1	380	#4-500	#4-500	400	3/0-500 <sup>(a)</sup>	3/0-500 <sup>(a)</sup>	400	3/0-500 <sup>(a)</sup>	3/0-500 <sup>(a)</sup>	N/A	N/A	N/A	
		2	175	#14-2/0	#14-2/0	250	#6-350	#6-350	250	#6-350	#6-350	N/A	N/A	N/A	

## Installation - Electrical

**Table 84. Customer Wire Selection - RTUD - 60 Hz (continued)**

Rated Size	# Voltage Conn	Wire Selection												
		Main Terminal Block			Disconnect			Circuit Breaker			Hi-Fault Panel Ckt Brkr			
		Size Amp	Wire Range XL YD		Size Amp	Wire Range XL YD		Size Amp	Wire Range XL YD		Size Amp	Wire Range XL YD		
200	1	760	N/A	#4-500 <sup>(a)</sup>	800	N/A	#1-500 <sup>(b)</sup>	1000	N/A	250-500 <sup>(c)</sup>	1000	N/A	250-500 <sup>(c)</sup>	
	2	760	N/A	#4-500 <sup>(a)</sup>	600	N/A	3/0-500 <sup>(a)</sup>	700	N/A	#1-500 <sup>(b)</sup>	700	N/A	#1-500 <sup>(b)</sup>	
230	1	760	N/A	#4-500 <sup>(a)</sup>	800	N/A	#1-500 <sup>(b)</sup>	1000	N/A	250-500 <sup>(c)</sup>	1000	N/A	250-500 <sup>(c)</sup>	
	2	760	N/A	#4-500 <sup>(a)</sup>	600	N/A	3/0-500 <sup>(a)</sup>	700	N/A	#1-500 <sup>(b)</sup>	700	N/A	#1-500 <sup>(b)</sup>	
250	380	1	760	#4-500 <sup>(a)</sup>	#4-500 <sup>(a)</sup>	600	3/0-500 <sup>(a)</sup>	3/0-500 <sup>(a)</sup>	600	3/0-500 <sup>(a)</sup>	3/0-500 <sup>(a)</sup>	600	3/0-500 <sup>(a)</sup>	3/0-500 <sup>(a)</sup>
		2	380	#4-500	#4-500	250	#6-350	#6-350	450	3/0-500 <sup>(a)</sup>	3/0-500 <sup>(a)</sup>	450	3/0-500 <sup>(a)</sup>	3/0-500 <sup>(a)</sup>
460	1	380	#4-500	#4-500	600	3/0-500 <sup>(a)</sup>	3/0-500 <sup>(a)</sup>	500	3/0-500 <sup>(a)</sup>	3/0-500 <sup>(a)</sup>	500	3/0-500 <sup>(a)</sup>	3/0-500 <sup>(a)</sup>	
		2	380	#4-500	#4-500	250	#6-350	#6-350	350	3/0-500 <sup>(a)</sup>	3/0-500 <sup>(a)</sup>	350	3/0-500 <sup>(a)</sup>	3/0-500 <sup>(a)</sup>
575	1	380	#4-500	#4-500	400	3/0-500 <sup>(a)</sup>	3/0-500 <sup>(a)</sup>	400	3/0-500 <sup>(a)</sup>	3/0-500 <sup>(a)</sup>	N/A	N/A	N/A	
		2	175	#14-2/0	#14-2/0	250	#6-350	#6-350	250	#6-350	#6-350	N/A	N/A	N/A

**Notes:**

1. Optional non-fused disconnect and circuit breaker.
2. Copper wire only, based on nameplate minimum circuit ampacity (MCA).
3. Standard condensing temperature option refers to entering condenser water temperatures 95°F (35°C) and below.
4. Circuit two information is the same as circuit one unless listed on a separate line below circuit one values.
5. XL - across-the-line starter and YD - wye-delta starter.

- (a) Will accept 2 conduits per phase in this size.  
 (b) Will accept 3 conduits per phase in this size.  
 (c) Will accept 4 conduits per phase in this size.  
 (d) Will accept 4 conduits per phase in this size.



## Installation - Electrical

**Table 85. Customer Wire Selection - RTWD - 50 Hz - standard efficiency - standard condensing temperature**

Rated Size	# Voltage	# Conn	Wire Selection											
			Main Terminal Block			Disconnect			Circuit Breaker			Hi-Fault Panel Ckt Brkr		
			Size Amp	Wire Range XL YD		Size Amp	Wire Range XL YD		Size Amp	Wire Range XL YD		Size Amp	Wire Range XL YD	
70	400	1	380	#4-500	#4-500	250	#6-#350	#6-#350	150	#6-#350	#6-#350	150	#6-#350	#6-#350
		2	175	#14-2/0	#14-2/0	100	#10-1/0	#10-1/0	100	#6-#350	#6-#350	100	#6-#350	#6-#350
80	400	1	380	#4-500	#4-500	250	#6-#350	#6-#350	175	#6-#350	#6-#350	175	#6-#350	#6-#350
		2	175	#14-2/0	#14-2/0	100	#10-1/0	#10-1/0	100 125	#6-#350	#6-#350	100 125	#6-#350	#6-#350
90	400	1	380	#4-500	#4-500	250	#6-#350	#6-#350	175	#6-#350	#6-#350	175	#6-#350	#6-#350
		2	175	#14-2/0	#14-2/0	100	#10-1/0	#10-1/0	125	#6-#350	#6-#350	125	#6-#350	#6-#350
100	400	1	380	#4-500	#4-500	250	#6-#350	#6-#350	200	#6-#350	#6-#350	200	#6-#350	#6-#350
		2	175	#14-2/0	#14-2/0	100	#10-1/0	#10-1/0	125 150	#6-#350	#6-#350	125 150	#6-#350	#6-#350
110	400	1	380	#4-500	#4-500	250	#6-#350	#6-#350	225	#6-#350	#6-#350	225	#6-#350	#6-#350
		2	175	#14-2/0	#14-2/0	100	#10-1/0	#10-1/0	150	#6-#350	#6-#350	150	#6-#350	#6-#350
120	400	1	380	#4-500	#4-500	250	#6-#350	#6-#350	250	#6-#350	#6-#350	250	#6-#350	#6-#350
		2	175	#14-2/0	#14-2/0	100	#10-1/0	#10-1/0	150 175	#6-#350	#6-#350	150 175	#6-#350	#6-#350
130	400	1	380	#4-500	#4-500	250	#6-#350	#6-#350	250	#6-#350	#6-#350	250	#6-#350	#6-#350
		2	175	#14-2/0	#14-2/0	100	#10-1/0	#10-1/0	175	#6-#350	#6-#350	175	#6-#350	#6-#350
140	400	1	380	#4-500	#4-500	250	#6-#350	#6-#350	300	3/0-500 <sup>(a)</sup>	3/0-500 <sup>(a)</sup>	300	3/0-500 <sup>(a)</sup>	3/0-500 <sup>(a)</sup>
		2	175	#14-2/0	#14-2/0	100 250	#10-1/0 #6-#350	#10-1/0 #6-#350	175 200	#6-#350	#6-#350	175 200	#6-#350	#6-#350
150	400	1	380	#4-500	#4-500	250	#6-#350	#6-#350	300	3/0-500 <sup>(a)</sup>	3/0-500 <sup>(a)</sup>	300	3/0-500 <sup>(a)</sup>	3/0-500 <sup>(a)</sup>
		2	175	#14-2/0	#14-2/0	250	#6-#350	#6-#350	200	#6-#350	#6-#350	200	#6-#350	#6-#350

**Notes:**

1. Optional non-fused disconnect and circuit breaker.
2. Copper wire only, based on nameplate minimum circuit ampacity (MCA).
3. Standard condensing temperature option refers to entering condenser water temperatures 95°F (35°C) and below.
4. Circuit two information is the same as circuit one unless listed on a separate line below circuit one values.
5. XL - across-the-line starter and YD - wye-delta starter.

(a) Will accept 2conduits per phase in this size.

## Installation - Electrical

**Table 86. Customer Wire Selection - RTWD - 50 Hz - high efficiency - standard condensing temperature**

Rated Size	# Voltage	# Conn	Wire Selection											
			Main Terminal Block			Disconnect			Circuit Breaker			Hi-Fault Panel Ckt Brkr		
			Size Amp	Wire Range		Size Amp	Wire Range		Size Amp	Wire Range		Size Amp	Wire Range	
	XL	YD		XL	YD		XL	YD		XL	YD			
60	400	1	380	#4-500	#4-500	100	#10-1/0	#10-1/0	125	#6-#350	#6-#350	125	#6-#350	#6-#350
		2	175	#14-2/0	#14-2/0	100	#10-1/0	#10-1/0	80	#6-#350	#6-#350	80	#6-#350	#6-#350
70	400	1	380	#4-500	#4-500	250	#6-#350	#6-#350	125	#6-#350	#6-#350	125	#6-#350	#6-#350
		2	175	#14-2/0	#14-2/0	100	#10-1/0	#10-1/0	100	#6-#350	#6-#350	100	#6-#350	#6-#350
80	400	1	380	#4-500	#4-500	250	#6-#350	#6-#350	175	#6-#350	#6-#350	175	#6-#350	#6-#350
		2	175	#14-2/0	#14-2/0	100	#10-1/0	#10-1/0	100 125	#6-#350	#6-#350	100 125	#6-#350	#6-#350
90	400	1	380	#4-500	#4-500	250	#6-#350	#6-#350	175	#6-#350	#6-#350	175	#6-#350	#6-#350
		2	175	#14-2/0	#14-2/0	100	#10-1/0	#10-1/0	125	#6-#350	#6-#350	125	#6-#350	#6-#350
100	400	1	380	#4-500	#4-500	250	#6-#350	#6-#350	200	#6-#350	#6-#350	200	#6-#350	#6-#350
		2	175	#14-2/0	#14-2/0	100	#10-1/0	#10-1/0	125 150	#6-#350	#6-#350	125 150	#6-#350	#6-#350
110	400	1	380	#4-500	#4-500	250	#6-#350	#6-#350	225	#6-#350	#6-#350	225	#6-#350	#6-#350
		2	175	#14-2/0	#14-2/0	100	#10-1/0	#10-1/0	150	#6-#350	#6-#350	150	#6-#350	#6-#350
120	400	1	380	#4-500	#4-500	250	#6-#350	#6-#350	250	#6-#350	#6-#350	250	#6-#350	#6-#350
		2	175	#14-2/0	#14-2/0	100	#10-1/0	#10-1/0	150 175	#6-#350	#6-#350	150 175	#6-#350	#6-#350
130	400	1	380	#4-500	#4-500	250	#6-#350	#6-#350	250	3/0-500 <sup>(a)</sup>	3/0-500 <sup>(a)</sup>	250	3/0-500 <sup>(a)</sup>	3/0-500 <sup>(a)</sup>
		2	175	#14-2/0	#14-2/0	100	#10-1/0	#10-1/0	175	#6-#350	#6-#350	175	#6-#350	#6-#350
140	400	1	380	#4-500	#4-500	250	#6-#350	#6-#350	300	3/0-500 <sup>(a)</sup>	3/0-500 <sup>(a)</sup>	300	3/0-500 <sup>(a)</sup>	3/0-500 <sup>(a)</sup>
		2	175	#14-2/0	#14-2/0	100 250	#10-1/0 #6-#350	#10-1/0 #6-#350	175 200	#6-#350	#6-#350	175 200	#6-#350	#6-#350
160	400	1	380	#4-500	#4-500	250	#6-#350	#6-#350	300	3/0-500 <sup>(a)</sup>	3/0-500 <sup>(a)</sup>	300	3/0-500 <sup>(a)</sup>	3/0-500 <sup>(a)</sup>
		2	175	#14-2/0	#14-2/0	250	#6-#350	#6-#350	200	#6-#350	#6-#350	200	#6-#350	#6-#350
180	400	1	380	#4-500	#4-500	250	#6-#350	#6-#350	350	3/0-500 <sup>(a)</sup>	3/0-500 <sup>(a)</sup>	350	3/0-500 <sup>(a)</sup>	3/0-500 <sup>(a)</sup>
		2	XL 175/ 380 YD 175	#14-2/0 #4-500	#14-2/0	250	#6-#350	#6-#350	200 250	#6-#350	#6-#350	200 250	#6-#350	#6-#350
200	400	1	380	#4-500	#4-500	400	3/0-500 <sup>(a)</sup>	3/0-500 <sup>(a)</sup>	350	3/0-500 <sup>(a)</sup>	3/0-500 <sup>(a)</sup>	350	3/0-500 <sup>(a)</sup>	3/0-500 <sup>(a)</sup>
		2	XL 380 YD 175	#4-500	#14-2/0	250	#6-#350	#6-#350	250	#6-#350	#6-#350	250	#6-#350	#6-#350
220	400	1	380	#4-500	#4-500	400	3/0-500 <sup>(a)</sup>	3/0-500 <sup>(a)</sup>	400	3/0-500 <sup>(a)</sup>	3/0-500 <sup>(a)</sup>	400	3/0-500 <sup>(a)</sup>	3/0-500 <sup>(a)</sup>
		2	XL 380 YD 175/ 380	#4-500	#14-2/0 #4-500	250	#6-#350	#6-#350	250 300	#6-#350 3/0-500 <sup>(a)</sup>	#6-#350 3/0-500 <sup>(a)</sup>	250 300	#6-#350 3/0-500 <sup>(a)</sup>	#6-#350 3/0-500 <sup>(a)</sup>
250	400	1	380	#4-500	#4-500	400	3/0-500 <sup>(a)</sup>	3/0-500 <sup>(a)</sup>	450	3/0-500 <sup>(a)</sup>	3/0-500 <sup>(a)</sup>	450	3/0-500 <sup>(a)</sup>	3/0-500 <sup>(a)</sup>
		2	380	#4-500	#4-500	250	#6-#350	#6-#350	300	3/0-500 <sup>(a)</sup>	3/0-500 <sup>(a)</sup>	300	3/0-500 <sup>(a)</sup>	3/0-500 <sup>(a)</sup>

**Notes:**

1. Optional non-fused disconnect and circuit breaker.
2. Copper wire only, based on nameplate minimum circuit ampacity (MCA).
3. Standard condensing temperature option refers to entering condenser water temperatures 95°F (35°C) and below.
4. Circuit two information is the same as circuit one unless listed on a separate line below circuit one values.
5. XL - across-the-line starter and YD - wye-delta starter.

(a) Will accept 2conduits per phase in this size.



## Installation - Electrical

**Table 87. Customer Wire Selection - RTWD - 50 Hz - high efficiency - high condensing temperature**

Rated Size	# Voltage	# Conn	Wire Selection											
			Main Terminal Block			Disconnect			Circuit Breaker			Hi-Fault Panel Ckt Brkr		
			Size Amp	Wire Range XL	Wire Range YD	Size Amp	Wire Range XL	Wire Range YD	Size Amp	Wire Range XL	Wire Range YD	Size Amp	Wire Range XL	Wire Range YD
60	400	1	380	#4-500	#4-500	250	#6-#350	#6-#350	150	#6-#350	#6-#350	150	#6-#350	#6-#350
		2	175	#14-2/0	#14-2/0	100	#10-1/0	#10-1/0	110 100	#6-#350	#6-#350	110 100	#6-#350	#6-#350
70	400	1	380	#4-500	#4-500	250	#6-#350	#6-#350	175	#6-#350	#6-#350	175	#6-#350	#6-#350
		2	175	#14-2/0	#14-2/0	100	#10-1/0	#10-1/0	125	#6-#350	#6-#350	125	#6-#350	#6-#350
80	400	1	380	#4-500	#4-500	250	#6-#350	#6-#350	225	#6-#350	#6-#350	225	#6-#350	#6-#350
		2	175	#14-2/0	#14-2/0	100	#10-1/0	#10-1/0	125 150	#6-#350	#6-#350	125 150	#6-#350	#6-#350
90	400	1	380	#4-500	#4-500	250	#6-#350	#6-#350	225	#6-#350	#6-#350	225	#6-#350	#6-#350
		2	175	#14-2/0	#14-2/0	100	#10-1/0	#10-1/0	150	#6-#350	#6-#350	150	#6-#350	#6-#350
100	400	1	380	#4-500	#4-500	250	#6-#350	#6-#350	250	#6-#350	#6-#350	250	#6-#350	#6-#350
		2	175	#14-2/0	#14-2/0	100 250	#10-1/0 #6-#350	#10-1/0 #6-#350	150 175	#6-#350	#6-#350	150 175	#6-#350	#6-#350
110	400	1	380	#4-500	#4-500	250	#6-#350	#6-#350	250	3/0-500 <sup>(a)</sup>	3/0-500 <sup>(a)</sup>	250	3/0-500 <sup>(a)</sup>	3/0-500 <sup>(a)</sup>
		2	175	#14-2/0	#14-2/0	250	#6-#350	#6-#350	200 175	#6-#350	#6-#350	200 175	#6-#350	#6-#350
120	400	1	380	#4-500	#4-500	250	#6-#350	#6-#350	300	3/0-500 <sup>(a)</sup>	3/0-500 <sup>(a)</sup>	300	3/0-500 <sup>(a)</sup>	3/0-500 <sup>(a)</sup>
		2	175	#14-2/0	#14-2/0	250	#6-#350	#6-#350	200 225	#6-#350	#6-#350	200 225	#6-#350	#6-#350
130	400	1	380	#4-500	#4-500	250	#6-350	#6-#350	300	3/0-500 <sup>(a)</sup>	3/0-500 <sup>(a)</sup>	300	3/0-500 <sup>(a)</sup>	3/0-500 <sup>(a)</sup>
		2	175	#14-2/0	#14-2/0	250	#6-350	#6-350	225 200	#6-350	#6-350	225 200	#6-350	#6-350
140	400	1	380	#4-500	#4-500	400	3/0-500 <sup>(a)</sup>	3/0-500 <sup>(a)</sup>	350	3/0-500 <sup>(a)</sup>	3/0-500 <sup>(a)</sup>	350	3/0-500 <sup>(a)</sup>	3/0-500 <sup>(a)</sup>
		2	XL 175/ 380 YD 175	#14-2/0 #4-500	#14-2/0	250	#6-350	#6-350	225 250	#6-350	#6-350	225 250	#6-350	#6-350
160	400	1	380	#4-500	#4-500	400	3/0-500 <sup>(a)</sup>	3/0-500 <sup>(a)</sup>	350	3/0-500 <sup>(a)</sup>	3/0-500 <sup>(a)</sup>	350	3/0-500 <sup>(a)</sup>	3/0-500 <sup>(a)</sup>
		2	XL 380 YD 175	#4-500	#14-2/0	250	#6-350	#6-350	250	#6-350	#6-350	250	#6-350	#6-350
180	400	1	380	#4-500	#4-500	400	3/0-500 <sup>(a)</sup>	3/0-500 <sup>(a)</sup>	400	3/0-500 <sup>(a)</sup>	3/0-500 <sup>(a)</sup>	400	3/0-500 <sup>(a)</sup>	3/0-500 <sup>(a)</sup>
		2	XL 380 YD 175/ 380	#4-500 #4-500	#14-2/0 #4-500	250	#6-350	#6-350	250 300	#6-350 3/0-500 <sup>(a)</sup>	#6-350 3/0-500 <sup>(a)</sup>	250 300	#6-350 3/0-500 <sup>(a)</sup>	#6-350 3/0-500 <sup>(a)</sup>
200	400	1	380	#4-500	#4-500	400	3/0-500 <sup>(a)</sup>	3/0-500 <sup>(a)</sup>	450	3/0-500 <sup>(a)</sup>	3/0-500 <sup>(a)</sup>	450	3/0-500 <sup>(a)</sup>	3/0-500 <sup>(a)</sup>
		2	380	#4-500	#4-500	250	#6-350	#6-350	300	3/0-500 <sup>(a)</sup>	3/0-500 <sup>(a)</sup>	300	3/0-500 <sup>(a)</sup>	3/0-500 <sup>(a)</sup>
220	400	1	380	#4-500	#4-500	400	3/0-500 <sup>(a)</sup>	3/0-500 <sup>(a)</sup>	500	3/0-500 <sup>(a)</sup>	3/0-500 <sup>(a)</sup>	500	3/0-500 <sup>(a)</sup>	3/0-500 <sup>(a)</sup>
		2	380	#4-500	#4-500	250	#6-350	#6-350	300 350	3/0-500 <sup>(a)</sup>	3/0-500 <sup>(a)</sup>	300 350	3/0-500 <sup>(a)</sup>	3/0-500 <sup>(a)</sup>
250	400	1	380	#4-500	#4-500	600	3/0-500 <sup>(a)</sup>	3/0-500 <sup>(a)</sup>	500	3/0-500 <sup>(a)</sup>	3/0-500 <sup>(a)</sup>	500	3/0-500 <sup>(a)</sup>	3/0-500 <sup>(a)</sup>
		2	380	#4-500	#4-500	250	#6-350	#6-350	350	3/0-500 <sup>(a)</sup>	3/0-500 <sup>(a)</sup>	350	3/0-500 <sup>(a)</sup>	3/0-500 <sup>(a)</sup>

**Notes:**

1. Optional non-fused disconnect and circuit breaker.
2. Copper wire only, based on nameplate minimum circuit ampacity (MCA).
3. Standard condensing temperature option refers to entering condenser water temperatures 95°F (35°C) and below.
4. Circuit two information is the same as circuit one unless listed on a separate line below circuit one values.
5. XL - across-the-line starter and YD - wye-delta starter.

(a) Will accept 2conduits per phase in this size.



## Installation - Electrical

**Table 88. Customer Wire Selection - RTWD - 50 Hz - premium efficiency - standard condensing temperature**

Wire Selection														
Rated Size	# Voltage	# Conn	Main Terminal Block			Disconnect			Circuit Breaker			Hi-Fault Panel Ckt Brkr		
			Size Amp	Wire Range XL	Wire Range YD	Size Amp	Wire Range XL	Wire Range YD	Size Amp	Wire Range XL	Wire Range YD	Size Amp	Wire Range XL	Wire Range YD
160	400	1	380	#4-500	#4-500	250	#6-350	#6-350	300	3/0-500 <sup>(a)</sup>	3/0-500 <sup>(a)</sup>	300	3/0-500 <sup>(a)</sup>	3/0-500 <sup>(a)</sup>
		2	175	#14-2/0	#14-2/0	250	#6-350	#6-350	200	#6-350	#6-350	200	#6-350	#6-350
180	400	1	380	#4-500	#4-500	250	#6-350	#6-350	350	3/0-500 <sup>(a)</sup>	3/0-500 <sup>(a)</sup>	350	3/0-500 <sup>(a)</sup>	3/0-500 <sup>(a)</sup>
		2	XL 175/ 380 YD 175	#14-2/0 #4-500	#14-2/0	250	#6-350	#6-350	200 250	#6-350	#6-350	200 250	#6-350	#6-350
200	400	1	380	#4-500	#4-500	400	3/0-500 <sup>(a)</sup>	3/0-500 <sup>(a)</sup>	350	3/0-500 <sup>(a)</sup>	3/0-500 <sup>(a)</sup>	350	3/0-500 <sup>(a)</sup>	3/0-500 <sup>(a)</sup>
		2	XL 380 YD 175	#4-500	#14-2/0	250	#6-350	#6-350	250	#6-350	#6-350	250	#6-350	#6-350

**Notes:**

1. Optional non-fused disconnect and circuit breaker.
2. Copper wire only, based on nameplate minimum circuit ampacity (MCA).
3. Standard condensing temperature option refers to entering condenser water temperatures 95°F (35°C) and below.
4. Circuit two information is the same as circuit one unless listed on a separate line below circuit one values.
5. XL - across-the-line starter and YD - wye-delta starter.

(a) Will accept 2 conduits per phase in this size.

**Table 89. Customer Wire Selection - RTWD - 50 Hz - premium efficiency - high condensing temperature**

Wire Selection														
Rated Size	# Voltage	# Conn	Main Terminal Block			Disconnect			Circuit Breaker			Hi-Fault Panel Ckt Brkr		
			Size Amp	Wire Range XL	Wire Range YD	Size Amp	Wire Range XL	Wire Range YD	Size Amp	Wire Range XL	Wire Range YD	Size Amp	Wire Range XL	Wire Range YD
160	400	1	380	#4-500	#4-500	400	3/0-500 <sup>(a)</sup>	3/0-500 <sup>(a)</sup>	350	3/0-500 <sup>(a)</sup>	3/0-500 <sup>(a)</sup>	350	3/0-500 <sup>(a)</sup>	3/0-500 <sup>(a)</sup>
		2	XL 380 YD 175	#4-500	#14-2/0	250	#6-350	#6-350	250	#6-350	#6-350	250	#6-350	#6-350
180	400	1	380	#4-500	#4-500	400	3/0-500 <sup>(a)</sup>	3/0-500 <sup>(a)</sup>	400	3/0-500 <sup>(a)</sup>	3/0-500 <sup>(a)</sup>	400	3/0-500 <sup>(a)</sup>	3/0-500 <sup>(a)</sup>
		2	XL 380 YD 175/ 380	#4-500	#14-2/0 #4-500	250	#6-350	#6-350	250 300	#6-350 3/0-500 <sup>(a)</sup>	#6-350 3/0-500 <sup>(a)</sup>	250 300	#6-350 3/0-500 <sup>(a)</sup>	#6-350 3/0-500 <sup>(a)</sup>
200	400	1	380	#4-500	#4-500	400	3/0-500 <sup>(a)</sup>	3/0-500 <sup>(a)</sup>	450	3/0-500 <sup>(a)</sup>	3/0-500 <sup>(a)</sup>	450	3/0-500 <sup>(a)</sup>	3/0-500 <sup>(a)</sup>
		2	380	#4-500	#4-500	250	#6-350	#6-350	300	3/0-500 <sup>(a)</sup>	3/0-500 <sup>(a)</sup>	300	3/0-500 <sup>(a)</sup>	3/0-500 <sup>(a)</sup>

**Notes:**

1. Optional non-fused disconnect and circuit breaker.
2. Copper wire only, based on nameplate minimum circuit ampacity (MCA).
3. Standard condensing temperature option refers to entering condenser water temperatures 95°F (35°C) and below.
4. Circuit two information is the same as circuit one unless listed on a separate line below circuit one values.
5. XL - across-the-line starter and YD - wye-delta starter.

(a) Will accept 2 conduits per phase in this size.

## Installer-Supplied Components

Customer wiring interface connections are shown in the electrical schematics and connection diagrams that are shipped with the unit. The installer must provide the following components if not ordered with the unit:

- Power supply wiring (in conduit) for all field-wired connections.
- All control (interconnecting) wiring (in conduit) for field supplied devices.
- Fused-disconnect switches or circuit breakers.
- Power factor correction capacitors. (See RLC-PRB023-EN)

## Power Supply Wiring

**⚠ WARNING**

**Proper Field Wiring and Grounding Required!**

All field wiring **MUST** be performed by qualified personnel. Improperly installed and grounded field wiring poses **FIRE** and **ELECTROCUTION** hazards. To avoid these hazards, you **MUST** follow requirements for field wiring installation and grounding as described in **NEC** and your local/state electrical codes. Failure to follow code could result in death or serious injury.

**⚠ WARNING**

**Hazardous Voltage!**

Disconnect all electric power, including remote disconnects before servicing. Follow proper lockout/tagout procedures to ensure the power can not be inadvertently energized. Failure to disconnect power before servicing could result in death or serious injury.

**NOTICE:**

**Use Copper Conductors Only!**

Unit terminals are not designed to accept other types of conductors. Failure to use copper conductors could result in equipment damage.

All power supply wiring must be sized and selected accordingly by the project engineer in accordance with **NEC** Table 310-16.

All wiring must comply with local codes and the National Electrical Code. The installing (or electrical) contractor must provide and install the system interconnecting wiring, as well as the power supply wiring. It must be properly sized and equipped with the appropriate fused disconnect switches.

The type and installation location(s) of the fused disconnects must comply with all applicable codes.

Knock-outs for wiring are located on the upper left side of the control panel. The wiring is passed through these conduits and connected to the terminal blocks, optional unit-mounted disconnects, or HACR type breakers. Refer to [Figure 44, p. 106](#).

To provide proper phasing of 3-phase input, make connections as shown in field wiring diagrams and as stated on the **WARNING** label in the starter panel. For additional information on proper phasing, refer to "Unit Voltage Phasing." Proper equipment ground must be provided to each ground connection in the panel (one for each customer-supplied conductor per phase).

115 volt field-provided connections (either control or power) are made through knockouts on the right side of the panel ([Figure 44](#)). Additional grounds may be required for each 115 volt power supply to the unit. Green lugs are provided for 115V customer wiring.

Figure 44. Power entrance

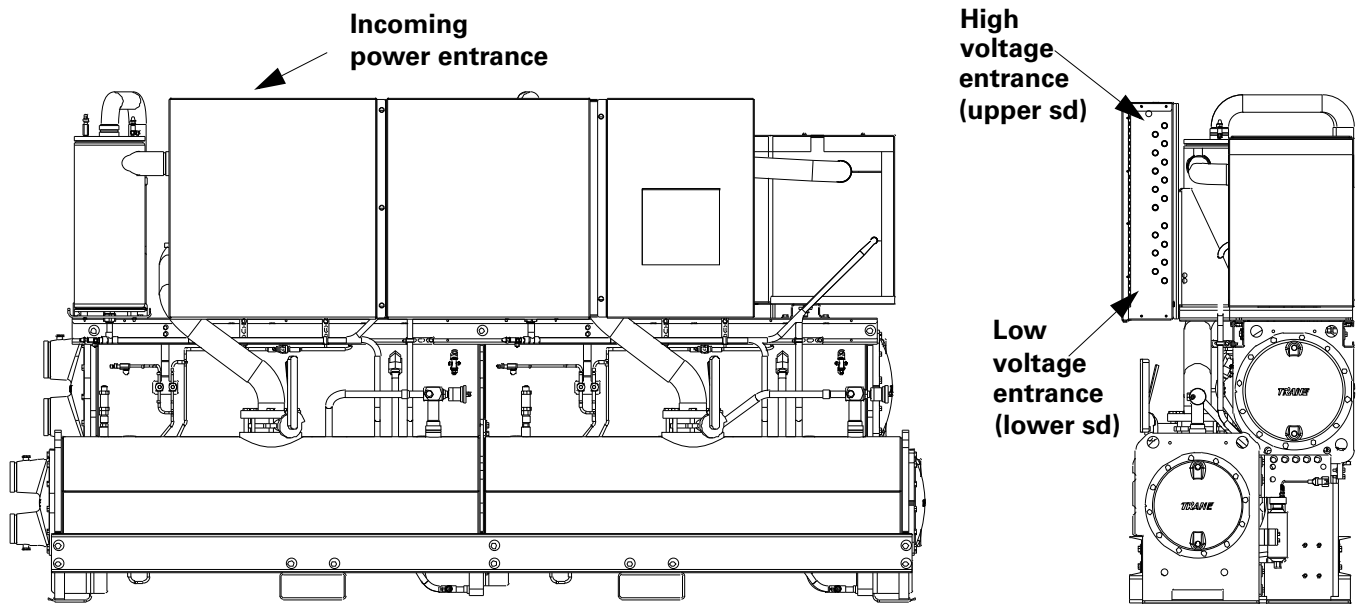

## Installation - Electrical

### Control Power Supply

The unit is equipped with a control power transformer; it is not necessary to provide additional control power voltage to the unit.

All units are factory-connected for appropriate labeled voltages.

## Interconnecting Wiring

### Chilled Water Flow (Pump) Interlock

If paddle option is selected, RTWD/RTUD Series R® chillers require a field-supplied control voltage contact input through a flow proving switch 5S5 and an auxiliary contact 5K9AUX. Connect the proving switch and auxiliary contact to 1A15 J3-1 and 1X4-1. Refer to the field wiring for details. The auxiliary contact can be BAS signal, starter contactor auxiliary, or any signal which indicates the pump is running. A flow switch is still required and cannot be omitted.

### Condenser Water Flow Interlock

If paddle option is selected, RTWD Series R® chillers require a field-supplied control voltage contact input through a flow proving switch 5S6 and an auxiliary contact 5K10AUX. Connect the proving switch and auxiliary contact to 1A15 J2-1 and 1X4-1. Refer to the field wiring for details. The auxiliary contact can be BAS signal, starter contactor auxiliary, or any signal which indicates the pump is running. A flow switch is still required and cannot be omitted.

### Chilled Water Pump Control

An evaporator water pump output relay closes when the chiller is given a signal to go into the Auto mode of operation from any source. The contact is opened to turn off the pump in the event of most machine level diagnostics to prevent the build up of pump heat.

#### **NOTICE:**

#### **Evaporator Damage!**

**All RTUD units (systems with a remote condenser) REQUIRE chilled water pumps be controlled by the Trane CH530 to avoid catastrophic damage to the evaporator due to freezing. It is strongly recommended that chilled water pump control also be used on RTWD to provide proper unit operation.**

The relay output from board 1A14 is required to operate the Evaporator Water Pump (EWP) contactor. Contacts should be compatible with 115/240VAC control circuit. The EWP relay operates in different modes depending on CH530 or Tracer commands, if available, or service pumpdown (See maintenance section). Normally, the EWP relay follows the AUTO mode of the chiller. Whenever the chiller has no diagnostics and is in the AUTO mode, regardless of where the auto command is coming from, the normally open relay is energized. When the chiller

exits the AUTO mode, the relay is timed open for an adjustable (using TechView) 0 to 30 minutes. The non-AUTO modes in which the pump is stopped, include Reset (88), Stop (00), External Stop (100), Remote Display Stop (600), Stopped by Tracer (300), Low Ambient Run Inhibit (200), and Ice Building complete (101).

Regardless of whether the chiller is allowed to control the pump on a full-time basis, if the MP calls for a pump to start and water does not flow, the evaporator may be damaged catastrophically. It is the responsibility of the installing contractor and/or the customer to ensure that a pump will start when called upon by the chiller controls.

**Table 90. Pump Relay Operation**

Chiller Mode	Relay Operation
Auto	Instant close
Ice Building	Instant close
Tracer Override	Close
Stop	Timed Open
Ice Complete	Instant Open
Diagnostics	Instant Open

Note: Exceptions are listed below.

When going from Stop to Auto, the EWP relay is energized immediately. If evaporator water flow is not established in 4 minutes and 15 sec., the CH530 de-energizes the EWP relay and generates a non-latching diagnostic. If flow returns (e.g. someone else is controlling the pump), the diagnostic is cleared, the EWP is re-energized, and normal control resumed.

If evaporator water flow is lost once it had been established, the EWP relay remains energized and a non-latching diagnostic is generated. If flow returns, the diagnostic is cleared and the chiller returns to normal operation.

In general, when there is either a non-latching or latching diagnostic, the EWP relay is turned off as though there was a zero time delay. Exceptions (see Table 90) whereby the relay continues to be energized occur with:

A Low Chilled Water Temp. diagnostic (non-latching) (unless also accompanied by an Evap Leaving Water Temperature Sensor Diagnostic)

OR

A starter contactor interrupt failure diagnostic, in which a compressor continues to draw current even after commanded to have shutdown

OR

A Loss of Evaporator Water Flow diagnostic (non-latching) and the unit is in the AUTO mode, after initially having proven evaporator water flow.

## Alarm and Status Relay Outputs (Programmable Relays)

A programmable relay concept provides for enunciation of certain events or states of the chiller, selected from a list of likely needs, while only using four physical output relays, as shown in the field wiring diagram. The four relays are provided (generally with a Quad Relay Output LLID) as part of the Alarm Relay Output Option. The relay's contacts are

isolated Form C (SPDT), suitable for use with 120 VAC circuits drawing up to 2.8 amps inductive, 7.2 amps resistive, or 1/3 HP and for 240 VAC circuits drawing up to 0.5 amp resistive.

The list of events/states that can be assigned to the programmable relays can be found in [Table 91](#). The relay will be energized when the event/state occurs.

**Table 91. Alarm and Status Relay Output Configuration Table**

	Description
Alarm - Latching	This output is true whenever there is any active diagnostic that requires a manual reset to clear, that affects either the Chiller, the Circuit, or any of the Compressors on a circuit. This classification does not include informational diagnostics.
Alarm - Auto Reset	This output is true whenever there is any active diagnostic that could automatically clear, that affects either the Chiller, the Circuit, or any of the Compressors on a circuit. This classification does not include informational diagnostics.
Alarm	This output is true whenever there is any diagnostic affecting any component, whether latching or automatically clearing. This classification does not include informational diagnostics
Alarm Ckt 1	This output is true whenever there is any diagnostic effecting Refrigerant Circuit 1, whether latching or automatically clearing, including diagnostics affecting the entire chiller. This classification does not include informational diagnostics.
Alarm Ckt 2	This output is true whenever there is any diagnostic affecting Refrigerant Circuit 2 whether latching or automatically clearing, including diagnostics effecting the entire chiller. This classification does not include informational diagnostics.
Chiller Limit Mode (with a 20 minute filter)	This output is true whenever the chiller has been running in one of the Unloading types of limit modes (Condenser, Evaporator, Current Limit or Phase Imbalance Limit) continuously for the last 20 minutes.
Circuit 1 Running	This output is true whenever any compressors are running (or commanded to be running) on Refrigerant Circuit 1, and false when no compressors are commanded to be running on that circuit.
Circuit 2 Running	This output is true whenever any compressors are running (or commanded to be running) on Refrigerant Circuit 2, and false when no compressors are commanded to be running on that circuit.
Chiller Running	This output is true whenever any compressors are running (or commanded to be running) on the chiller and false when no compressors are commanded to be running on the chiller.
Maximum Capacity (software 18.0 or later)	This output is true whenever the chiller has reached maximum capacity or had reached its maximum capacity and since that time has not fallen below 70% average current relative to the rated AHRI current for the chiller. The output is false when the chiller falls below 70% average current and, since that time, had not reestablished maximum capacity.

### Relay Assignments Using TechView

CH530 ServiceTool (TechView) is used to install the Alarm and Status Relay Option package and assign any of the above list of events or status to each of the four relays provided with the option. The relays to be programmed are referred to by the relay's terminal numbers on the LLID board 1A13.

The default assignments for the four available relays of the RTWD/RTUD Alarm and Status Package Option are:

**Table 92. Default Assignments**

Relay	
Relay 1 Terminals J2 -12,11,10:	Alarm
Relay 2 Terminals J2 - 9,8,7:	Chiller Running
Relay 3 Terminals J2-6,5,4:	Maximum Capacity (software 18.0 or later)
Relay 4 Terminals J2-3,2,1:	Chiller Limit

If any of the Alarm/Status relays are used, provide electrical power, 115 VAC with fused-disconnect to the panel and wire through the appropriate relays/terminals on 1A13. Provide wiring (switched hot, neutral, and ground connections) to the remote annunciation devices.

Do not use power from the chiller's control panel transformer to power these remote devices. Refer to the field diagrams which are shipped with the unit.

### Low Voltage Wiring

#### **WARNING**

#### **Proper Field Wiring and Grounding Required!**

**All field wiring MUST be performed by qualified personnel. Improperly installed and grounded field wiring poses FIRE and ELECTROCUTION hazards. To avoid these hazards, you MUST follow requirements for field wiring installation and grounding as described in NEC and your local/state electrical codes. Failure to follow code could result in death or serious injury.**

The remote devices described below require low voltage wiring. All wiring to and from these remote input devices to the Control Panel must be made with shielded, twisted pair conductors. Be sure to ground the shielding only at the control panel.

Note: To prevent control malfunctions, do not run low voltage wiring (<30 V) in conduit with conductors carrying more than 30 volts.

## Installation - Electrical

### Emergency Stop

CH530 provides auxiliary control for a customer specified/ installed latching trip out. When this customer-furnished remote contact 5K24 is provided, the chiller will run normally when the contact is closed. When the contact opens, the unit will trip on a manually resettable diagnostic. This condition requires manual reset at the chiller switch on the front of the control panel.

Connect low voltage leads to terminal strip locations on 1A5, J2-3 and 4. Refer to the field diagrams that are shipped with the unit.

Silver or gold-plated contacts are recommended. These customer-furnished contacts must be compatible with 24 VDC, 12 mA resistive load.

### External Auto/Stop

If the unit requires the external Auto/Stop function, the installer must provide leads from the remote contacts 5K23 to the proper terminals on board 1A5 J2-1 and 2.

The chiller will run normally when the contacts are closed. When either contact opens, the compressor(s), if operating, will go to the RUN:UNLOAD operating mode and cycle off. Unit operation will be inhibited. Closure of the contacts will permit the unit to return to normal operation.

Field-supplied contacts for all low voltage connections must be compatible with dry circuit 24 VDC for a 12 mA resistive load. Refer to the field diagrams that are shipped with the unit.

### External Circuit Lockout – Circuit #1 and Circuit #2

CH530 provides auxiliary control of a customer specified or installed contact closure, for individual operation of either Circuit #1 or #2. If the contact is closed, the respective refrigerant circuit will not operate. In the schematic, 5K21 is shown as controlling circuit 1 and 5K22 is controlling circuit 2.

Upon contact opening, the refrigerant circuit will run normally. This feature is used to restrict total chiller operation, e.g. during emergency generator operations.

Connections to board 1A6 are shown in the field diagrams that are shipped with the unit.

These customer-supplied contact closures must be compatible with 24 VDC, 12 mA resistive load. Silver or gold plated contacts are recommended.

### Ice Building Option

CH530 provides auxiliary control for a customer specified/ installed contact closure for ice building if so configured and enabled. This output is known as the Ice Building Status Relay. The normally open contact will be closed when ice building is in progress and open when ice building has been normally terminated either through Ice Termination setpoint being reached or removal of the Ice

Building command. This output is for use with the ice storage system equipment or controls (provided by others) to signal the system changes required as the chiller mode changes from “ice building” to “ice complete”. When contact 5K20 is provided, the chiller will run normally when the contact is open.

CH530 will accept either an isolated contact closure (External Ice Building command) or a Remote Communicated input (Tracer) to initiate and command the Ice Building mode.

CH530 also provides a “Front Panel Ice Termination Setpoint” through TechView, adjustable from 20 to 31°F (-6.7 to -0.5°C) in at least 1°F (1°C) increments.

When in the Ice Building mode, and the evaporator entering water temperature drops below the ice termination setpoint, the chiller terminates the Ice Building mode and changes to the Ice Building Complete Mode.

### **NOTICE:**

#### **Evaporator Damage!**

**Freeze inhibitor must be adequate for the leaving water temperature. Failure to do so may result in damage to system components.**

Techview must also be used to enable or disable Ice Machine Control. This setting does not prevent the Tracer from commanding Ice Building mode.

Upon contact closure, the CH530 will initiate an ice building mode, in which the unit runs fully loaded at all times. Ice building shall be terminated either by opening the contact or based on the entering evaporator water temperature. CH530 will not permit the ice building mode to be reentered until the unit has been switched out of ice building mode (open 5K20 contacts) and then switched back into ice building mode (close 5K20 contacts.)

In ice building, all limits (freeze avoidance, evaporator, condenser, current) will be ignored. All safeties will be enforced.

If, while in ice building mode, the unit gets down to the freeze stat setting (water or refrigerant), the unit will shut down on a manually resettable diagnostic, just as in normal operation.

Connect leads from 5K20 to the proper terminals of board 1A10. Refer to the field diagrams which are shipped with the unit.

Silver or gold-plated contacts are recommended. These customer furnished contacts must be compatible with 24 VDC, 12 mA resistive load.



## Installation - Electrical

### External Chilled or Hot Water Setpoint (ECWS/EHWS) Option

The CH530 provides inputs that accept either 4-20 mA or 2-10 VDC signals to set the external water setpoint (EWS).

- When the unit is in cooling mode, the EWS will correspond to the chilled water setpoint (ECWS).
- When the unit is in heating mode, the EWS will correspond to the hot water setpoint (EHWS).

This is not a reset function. The input defines the set point. This input is primarily used with generic BAS (building automation systems). The water setpoint set via the DynaView or through digital communication with Tracer (Comm3). See Figure 45, p. 111 for wiring diagrams.

The chilled water setpoint may be changed from a remote location by sending either a 2-10 VDC or 4-20 mA signal to the 1A7, J2-5 and 6. The widest range of temperatures available for the 2-10 VDC and 4-20 mA signals each correspond to:

- ECWS of 10 to 65°F (-12.22 to 18.4°C)
- EHWS of 68 to 140°F (20 - 60°C).

The external chilled water setpoint (ECWS) and external hot water setpoint (EHWS) minimum and maximum values are configurable. See Table 93 for default values.

**Table 93. Default minimum and maximum values**

External Water Setpoint	Default Temperature	
	Minimum	Maximum
Chilled (ECWS)	34°F (1.1°C)	65°F (18.4°C)
Hot (EHWS)	86°F (30°C)	122°F (50°C)

The equations in Table 94 apply if using default minimum and maximum values, as shown in above.

**Table 94. EWS equations - default minimum and maximum values<sup>(a)</sup>**

Chilled Water Setpoint	Voltage Signal	Current Signal
As generated from external source	VDC = 0.1455*(ECWS) +0.5454	mA = 0.2909*(ECWS) +1.0909
As processed by CH530	ECWS = 6.875*(VDC)-3.75	ECWS = 3.4375*(mA)-3.75
Hot Water Setpoint	Voltage Signal	Current Signal
As generated from external source	VDC = 0.2222*(EHWS) -17.1092	mA = 0.4444*(EHWS) -34.2184
As processed by CH530	EHWS = 4.5*(VDC)+77	EHWS = 2.25*(mA)+77

(a) Temperatures are in units of °F.

If minimum and maximum values have been changed from default values in Table 93, use the following equations:

**Table 95. EWS equations - any minimum and maximum values<sup>(a)</sup>**

<b>For Voltage Input Signal</b>	$EWS = Min + (Max - Min) * (VDC - 2) / 8$
<b>For Current Input Signal</b>	$EWS = Min + (Max - Min) * (mA - 4) / 16$

(a) Temperatures are in units of °F.

If the ECWS/EHWS input develops an open or short, the LLID will report either a very high or very low value back to the main processor. This will generate an informational diagnostic and the unit will default to using the Front Panel (DynaView) Chilled/Hot Water Setpoint.

TechView Service Tool is used to set the input signal type from the factory default of 2-10 VDC to that of 4-20 mA. TechView is also used to install or remove the External Chilled Water Setpoint option as well as a means to enable and disable ECWS.

### External Current Limit Setpoint (ECLS) Option

Similar to the above, the CH530 also provides for an optional External Current Limit Setpoint that will accept either a 2-10VDC (default) or a 4-20 mA signal. The Current Limit Setting can also be set via the DynaView or through digital communication with Tracer (Comm 3). The arbitration of the various sources of current limit is described in the flow charts at the end of this section. The External Current Limit Setpoint may be changed from a remote location by hooking up the analog input signal to the board 1A7, J2-2 and 3. Refer to the following paragraph on Analog Input Signal Wiring Details. The following equations apply for ECLS:

	Voltage Signal	Current Signal
As generated from external source	$VDC = 0.133 * (\%) - 6.0$	$mA = 0.266 * (\%) - 12.0$
As processed by UCM	$\% = 7.5 * (VDC) + 45.0$	$\% = 3.75 * (mA) + 45.0$

If the ECLS input develops an open or short, the LLID will report either a very high or very low value back to the man processor. This will generate an informational diagnostic and the unit will default to using the Front Panel (DynaView) Current Limit Setpoint.

The TechView Service Tool must be used to set the input signal type from the factory default of 2-10 VDC to that of 4-20 mA current. TechView must be also be used to install or remove the External Current Limit Setpoint Option for field installation, or can be used to enable or disable the feature (if installed).

ECLS and ECWS Analog Input Signal Wiring Details:

Both the ECWS and ECLS can be connected and setup as either a 2-10 VDC (factory default), 4-20 mA, or resistance input (also a form of 4-20mA) as indicated below.

## Installation - Electrical

Depending on the type to be used, the TechView Service Tool must be used to configure the LLID and the MP for the proper input type that is being used. This is accomplished by a setting change on the Custom Tab of the Configuration View within TechView.

The J2-3 and J2-6 terminal is chassis grounded and terminal J2-1 and J2-4 can be used to source 12 VDC. The ECLS uses terminals J2-2 and J2-3. ECWS uses terminals J2-5 and J2-6. Both inputs are only compatible with high-side current sources.

**Figure 45. Wiring examples for ECLS and ECWS/EHWS**

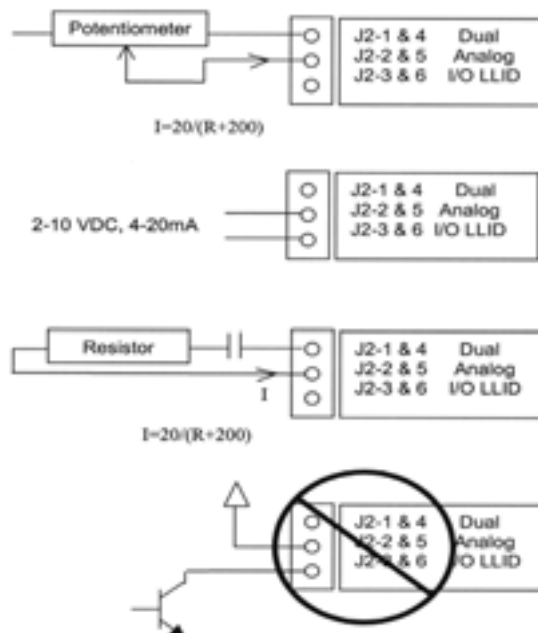

### Chilled Water Reset (CWR)

CH530 resets the chilled water temperature set point based on either return water temperature, or outdoor air temperature. Return Reset is standard, Outdoor Reset is optional.

The following shall be selectable:

- One of three Reset Types: None, Return Water Temperature Reset, Outdoor Air Temperature Reset, or Constant Return Water Temperature Reset.
- Reset Ratio Set Points.
- For outdoor air temperature reset there shall be both positive and negative reset ratio's.
- Start Reset Set Points.
- Maximum Reset Set Points.

The equations for each type of reset are as follows:

Return

$$CWS' = CWS + \text{RATIO} (\text{START RESET} - (\text{TWE} - \text{TWL}))$$

and  $CWS' > \text{or} = CWS$

and  $CWS' - CWS < \text{or} = \text{Maximum Reset}$

Outdoor

$$CWS' = CWS + \text{RATIO} * (\text{START RESET} - \text{TOD})$$

and  $CWS' > \text{or} = CWS$

and  $CWS' - CWS < \text{or} = \text{Maximum Reset}$

where

CWS' is the new chilled water set point or the "reset CWS"

CWS is the active chilled water set point before any reset has occurred, e.g. normally Front Panel, Tracer, or ECWS

RESET RATIO is a user adjustable gain

START RESET is a user adjustable reference

TOD is the outdoor temperature

TWE is entering evap. water temperature

TWL is leaving evap. water temperature

MAXIMUM RESET is a user adjustable limit providing the maximum amount of reset. For all types of reset,  $CWS' - CWS < \text{or} = \text{Maximum Reset}$ .

Reset Type	Reset Ratio Range	Start Reset Range °F (°C)	Max Reset Range °F (°C)	Increment IP	SI	Factory Default Value
Return	10 to 120%	4 - 30 (2.2 - 16.7)	0 - 20 (0.0 - 11.1)	1%	1%	50%
Outdoor	80 to -80%	50 - 130 (10 - 54.4)	0 - 20 (0.0 - 11.1)	1%	1%	10%

In addition to Return and Outdoor Reset, the MP provides a menu item for the operator to select a Constant Return Reset. Constant Return Reset will reset the leaving water temperature set point so as to provide a constant entering water temperature. The Constant Return Reset equation is the same as the Return Reset equation except on selection of Constant Return Reset, the MP will automatically set Ratio, Start Reset, and Maximum Reset to the following.

RATIO = 100%

START RESET = Design Delta Temp.

MAXIMUM RESET = Design Delta Temp.

The equation for Constant Return is then as follows:

$$CWS' = CWS + 100\% (\text{Design Delta Temp.} - (\text{TWE} - \text{TWL}))$$

and  $CWS' > \text{or} = CWS$

and  $CWS' - CWS < \text{or} = \text{Maximum Reset}$

When any type of CWR is enabled, the MP will step the Active CWS toward the desired CWS' (based on the above equations and setup parameters) at a rate of 1 degree F every 5 minutes until the Active CWS equals the desired CWS'. This applies when the chiller is running.

When the chiller is not running, CWS is reset immediately (within one minute) for Return Reset and at a rate of 1 degree F every 5 minutes for Outdoor Reset. The chiller will start at the Differential to Start value above a fully reset CWS or CWS' for both Return and Outdoor Reset.



### Outdoor Air Temperature Sensor Installation Requirements

The outdoor air temperature sensor is optional for the RTWD water cooled units, but is a required sensor for the RTUD compressor chiller units. The sensor is required as an important input to the condenser fan control algorithm as well as for the low outdoor air ambient lockout feature. The temperature sensor probe is shipped separately inside the control panel.

It is necessary for the chiller installer to locate and install the separate outdoor air sensor probe at the remote air cooled condenser at a location to sense the coil's entering air temperature, while avoiding direct sunlight. It should be located at least 2" from the coil face and somewhere "in-between" the two refrigerant circuits. Where the condenser installation is such that the two refrigerant circuit's condensers are physically separate from each other, or one circuit is more likely to see re-circulated warmer air, an attempt should be made to locate the probe to see an average temperature of the two separate condensers.

**Important:** The probe provided must not be substituted with another probe, as the probe and the electronics are "matched / calibrated" at the factory for accuracy.

A twisted pair sheathed cable shall be run and connected between the probe at the remote condenser and its LLID module in the chiller control panel. The sensor's circuit is a class II power limited analog circuit and therefore the wire should not be run in close proximity to any power or line voltage wiring. The splices at the condenser end, should be made to be water tight. The wire run should be physically supported at equal intervals with consideration for safety and reliability/durability with wire ties or similar to meet local codes.

### Remote Air Cooled Condenser

If using a Levitor II remote air cooled condenser, refer to wiring diagram provided from Krack located in the control panel. If you have additional questions, please contact Pueblo Technical Service.

### Fan Control for the Remote Air Cooled Condenser

The CH530 Controls for the RTUD compressor chiller provide as an option, the flexible and full control of a 2-circuit remote air cooled condenser fans. In addition to the option for controlling between 2 to 8 fixed speed fans per circuit (or multiples thereof), a separate additional option includes the ability to control either two speed fans or variable speed fan/drive combinations in conjunction with other fixed speed fans, to provide low ambient outdoor air temperature capability. The controls will also provide an option for a simple per circuit interlock output (in lieu of actual fan control) to use in the scenario in which independent fan head pressure or differential pressure

controls (by others) is applied. It is recommended however, that for the best overall unit performance, the integral fan control option is selected.

The controls support control of a remote, air cooled condenser fan deck, from 2 to 8 fans per circuit (1-8 fans for variable speed). It supports options to control the following types of standard ambient outdoor air temperature fan decks: 1) all fans fixed speed, and 2) all fans two speed. It will also support the following low ambient outdoor air temperature fan decks 1) one fan per circuit is Two-Speed, (remaining fans fixed speed), and 2) One fan per circuit is variable speed i.e. variable frequency drive (VFD), (remaining fans fixed speed). In the variable fan low ambient outdoor air option the VFD fan and fixed speed fans are sequenced accordingly to provide continuous control from 0-100% air flow per circuit. Fan staging provides the correct combination of fixed speed fan relay, VFD relay (to enable operation of the VFD), and speed outputs to provide air flow control commanded by the fan algorithm running inside the CH530 Main Processor. The fan deck arrangement is independently configurable per circuit.

Since the condenser is provided separately from the RTUD compressor chiller, the RTUD electrical panel design does not provide for condensing unit's control power requirements. The chiller's control power transformer is not sized to provide the control power for the additional fan contactor loads. The CH530 controls, when properly optioned, will provide for pilot duty rated relays, low voltage binary inputs, and low voltage analog outputs to control the remote contactors and inverters provided by others. The CH530 fan control relays located in the chiller control panel, are intended to control the fan contactors that are located in the remote air cooled condenser panel. The Fan Control Relays are rated for up to 7.2 Amps resistive, 2.88 Amps pilot duty 1/3 HP, 7.2 FLA at 120 VAC, and up to 5 Amps general purpose at 240 VAC. All wiring for the field connections to the condenser, will have screw terminals for termination in the RTUD control panel with the exception of the outdoor air temperature sensor (addressed above). Refer to the wiring diagrams.

Separate fan control algorithms are used for fixed speed and variable speed systems. For the variable speed fan deck option, the fan control reverts to fixed speed control if an inverter drive fault is detected through a binary input interface with the drive. An informational diagnostic is also provided to indicate the issue.

Reference "Controls Interface" section for fan control setting information.

## Communications Interface

### Optional Tracer Communications Interface

This option allows the Tracer CH530 controller to exchange information (e.g. operating setpoints and Auto/Standby commands) with a higher-level control device, such as a Tracer Summit or a multiple-machine controller. A



## Installation - Electrical

shielded, twisted pair connection establishes the bi-directional communications link between the Tracer CH530 and the building automation system.

Note: To prevent control malfunctions, do not run low voltage wiring (<30 V) in conduit with conductors carrying more than 30 volts.

### ⚠ WARNING

#### Proper Field Wiring and Grounding Required!

All field wiring **MUST** be performed by qualified personnel. Improperly installed and grounded field wiring poses **FIRE** and **ELECTROCUTION** hazards. To avoid these hazards, you **MUST** follow requirements for field wiring installation and grounding as described in **NEC** and your local/state electrical codes. Failure to follow code could result in death or serious injury.

Field wiring for the communication link must meet the following requirements:

- All wiring must be in accordance with the NEC and local codes.
- Communication link wiring must be shielded, twisted pair wiring (Belden 8760 or equivalent). See the table below for wire size selection:

**Table 96. Wire Size**

Wire Size	Maximum Length of Communication Wire
14 AWG (2.5 mm <sup>2</sup> )	5,000 ft (1525 m)
16 AWG (1.5 mm <sup>2</sup> )	2,000 ft (610 m)
18 AWG (1.0 mm <sup>2</sup> )	1,000 ft (305 m)

- The communication link cannot pass between buildings.
- All units on the communication link can be connected in a "daisy chain" configuration.

### LonTalk Communications Interface for Chillers (LCI-C)

CH530 provides an optional LonTalk Communication Interface (LCI-C) between the chiller and a Building Automation System (BAS). An LCI-C LLID shall be used to provide "gateway" functionality between a LonTalk compatible device and the Chiller. The inputs (outputs include both mandatory and optional network variables as established by the LonMark Functional Chiller Profile 8040.

#### Installation Recommendations

- 22 AWG Level 4 unshielded communication wire recommended for most LCI-C installations
- LCI-C link limits: 4500 feet, 60 devices
- Termination resistors are required
- 105 ohms at each end for Level 4 wire
- 82 ohms at each end for Trane "purple" wire
- LCI-C topology should be daisy chain

- Zone sensor communication stubs limited to 8 per link, 50 feet each (maximum)
- One repeater can be used for an additional 4500 feet, 60 devices, 8 communication stubs

**Table 97. LonTalk points list**

LonTalk Communications Interface			
Inputs	Variable type		SNVT_Type
Chiller Enable/Disable	binary	start(1)/stop(0)	SNVT_switch
Chilled Water Setpoint	analog	temperature	SNVT_temp_p
Current Limit Setpoint	analog	% current	SNVT_lev_percent
Chiller Mode	Note 1		SNVT_hvac_mode
Outputs	Variable type		SNVT_Type
Outputs	Variable type		SNVT_Type
Chiller On/Off	binary	on(1)/off(0)	SNVT_switch
Active Chilled Water Setpoint	analog	temperature	SNVT_temp_p
Percent RLA	analog	% current	SNVT_lev_percent
Active Current Limit Setpoint	analog	% current	SNVT_lev_percent
Leaving Chilled Water Temperature	analog	temperature	SNVT_temp_p
Entering Chilled Water Temperature	analog	temperature	SNVT_temp_p
Entering Condenser Water Temperature	analog	temperature	SNVT_temp_p
Leaving Condenser Water Temperature	analog	temperature	SNVT_temp_p
Alarm Description	See Note 2		SNVT_str_asc
Chiller Status	See Note 3		SNVT_chlr_status

#### Notes:

1. Chiller Mode is used to place the chiller into an alternate mode; Cool or Ice Build
2. Alarm Description denotes alarm severity and target.  
Severity: no alarm, warning, normal shutdown, immediate shutdown  
Target: Chiller, Platform, Ice Building (Chiller is refrigerant circuit and Platform is control circuit)
3. Chiller Status describes Chiller Run Mode and Chiller Operating Mode.  
Run Modes: Off, Starting, Running, Shutting Down  
Operating Modes: Cool, Ice Build  
States: Alarm, Run Enabled, Local Control, Limited, CHW Flow, Cond Flow

### BACnet Communications Interface for Chillers (BCI-C)

The optional BACnet Communication Interface for Chillers (BCI-C) is comprised of a Tracer UC400 controller with interface software. It is a non-programmable communications module that allows the RTWD or RTUD unit to communicate on a BACnet communications network.

#### BACnet Data Points and Configuration Property

**Definitions.** The BCI-C device allows certain models of Trane chillers with CH530 controls to communicate with



## Installation - Electrical

BACnet systems and devices using BACnet MS/TP. This section includes information about:

- BACnet protocol implementation conformance statement (PICS)
- Object types: descriptions and configuration (see [Table 98, p. 115](#))
- BACnet protocol: data link layers, device address binding, networking options, and character sets
- Object data points and configurations

### BACnet Protocol Implementation Conformance Statement (PICS).

#### Standardized Device Profile (Annex L)

Profile Description	Supported Profile
BACnet Advanced Application Controller (B-AAC)	
BACnet Application Specific Controller (B-ASC)	ü
BACnet Building Controller (B-BC)	
BACnet Operator Workstation (B-OWS)	
BACnet Smart Actuator (B-SA)	
BACnet Smart Sensor (B-SS)	

#### Interoperability Building Blocks (Annex K)

Data Sharing Description	Supported BIBB
Data Sharing-COV-B (DS-COV-B)	
Data Sharing-ReadProperty-A (DS-RP-A)	ü
Data Sharing-ReadProperty-B (DS-RP-B)	ü
Data Sharing-ReadPropertyMultiple-B (DS-RPM-B)	ü
Data Sharing-WriteProperty-A (DS-WP-A)	ü
Data Sharing-WriteProperty-B (DS-WP-B)	ü
Data Sharing-WritePropertyMultiple-B (DS-WPM-B)	ü
Alarm and Event Management Description	Supported BIBB
Alarm and Event-ACKI-B (AE-ACK-B)	ü
Alarm and Event-Alarm Summary-B (AE-ASUM-B)	ü
Alarm and Event-Enrollment Summary-B (AE-ESUM-B)	ü
Alarm and Event-Information-B (AE-INFO-B)	ü
Alarm and Event-Notification Internal-B (AE-N-I-B)	ü
Trending Description	Supported BIBB
Trending-Automated Trend Retrieval-B (T-ATR-B)	ü
Trending-viewing and Modifying Trends Internal-B (T-VMT-I-B)	ü
Device Management Description	Supported BIBB
Device Management-Backup and Restore-B (DM-BR-B)	ü

Device Management-Device Communication Control-B (DM-DCC-B)	ü
Device Management-Dynamic Device Binding-A (DM-DDB-A)	ü
Device Management-Dynamic Device Binding-B (DM-DDB-B)	ü
Device Management-Dynamic Object Binding-B (DM-DOB-B)	ü
Device Management-List Manipulation-B (DM-LM-B)	ü
Device Management-Object Creation and Deletion-B (DM-OCD-B)	ü
Device Management-Private Transfer-A (DM-PT-A)	ü
Device Management-Private Transfer-B (DM-PT-B)	ü
Device Management-Reinitialize Device-B (DM-RD-B)	ü
Device Management-TimeSynchronization-B (DM-TS-B)	ü

#### Segmentation Capability

Segmentation Description	Supported Segment
Segmented Requests/ Window Size: 1	ü
Segmented Responses/ Window Size: 1	ü

## Installation - Electrical

### Object Types

**Table 98. Descriptions and configurations**

Object Type	Required Properties Read	Properties Written <sup>(a)</sup>	Optional Properties Read	Ability to Create	Ability to Delete
Analog Input	<ul style="list-style-type: none"> <li>• Object_Identifier</li> <li>• Object_Name</li> <li>• Object_Type</li> <li>• Present_Value</li> <li>• Status_Flags</li> <li>• Event_State</li> <li>• Out_Of_Service</li> <li>• Units</li> </ul>	<ul style="list-style-type: none"> <li>• Object_Name</li> <li>• Description</li> <li>• Out_Of_Service</li> <li>• Present_Value</li> <li>• Reliability</li> <li>• Min_Pres_Value</li> <li>• Max_Pres_Value</li> <li>• COV_Increment</li> <li>• Time_Delay</li> <li>• Notification_Class</li> <li>• High_Limit</li> <li>• Low_Limit</li> <li>• Deadband</li> <li>• Limit_Enable</li> <li>• Event_Enable</li> <li>• Notify_Type</li> </ul>	<ul style="list-style-type: none"> <li>• Description</li> <li>• Reliability</li> <li>• Min_Pres_Value</li> <li>• Max_Pres_Value</li> <li>• COV_Increment</li> <li>• Time_Delay</li> <li>• Notification_Class</li> <li>• High_Limit</li> <li>• Low_Limit</li> <li>• Deadband</li> <li>• Limit_Enable</li> <li>• Event_Enable</li> <li>• Acked_Transitions</li> <li>• Notify_Type</li> <li>• Event_Time_Stamps</li> </ul>	Yes	Yes, only user created objects
Analog Output	<ul style="list-style-type: none"> <li>• Object_Identifier</li> <li>• Object_Name</li> <li>• Object_Type</li> <li>• Present_Value</li> <li>• Status_Flags</li> <li>• Event_State</li> <li>• Out_Of_Service</li> <li>• Units</li> <li>• Priority_Array</li> <li>• Relinquish_Default</li> </ul>	<ul style="list-style-type: none"> <li>• Object_Name</li> <li>• Description</li> <li>• Out_Of_Service</li> <li>• Present_Value</li> <li>• Reliability</li> <li>• Min_Pres_Value</li> <li>• Max_Pres_Value</li> <li>• Relinquish_Default</li> <li>• COV_Increment</li> <li>• Time_Delay</li> <li>• Notification_Class</li> <li>• High_Limit</li> <li>• Low_Limit</li> <li>• Deadband</li> <li>• Limit_Enable</li> <li>• Event_Enable</li> <li>• Notify_Type</li> </ul>	<ul style="list-style-type: none"> <li>• Description</li> <li>• Reliability</li> <li>• Min_Pres-Value</li> <li>• Max_Pres_Value</li> <li>• COV_Increment</li> <li>• Time_Delay</li> <li>• Notification_Class</li> <li>• High_Limit</li> <li>• Low_Limit</li> <li>• Deadband</li> <li>• Limit_Enable</li> <li>• Event_Enable</li> <li>• Acked_Transitions</li> <li>• Notify_Type</li> <li>• Event_Time_Stamps</li> </ul>	Yes	Yes, only user created objects
Analog Value	<ul style="list-style-type: none"> <li>• Object_Identifier</li> <li>• Object_Name</li> <li>• Object_Type</li> <li>• Present_Value</li> <li>• Status_Flags</li> <li>• Event_State</li> <li>• Out_Of_Service</li> <li>• Units</li> </ul>	<ul style="list-style-type: none"> <li>• Object_Name</li> <li>• Description</li> <li>• Out_Of_Service</li> <li>• Present_Value</li> <li>• Reliability</li> <li>• Relinquish_Default</li> <li>• COV_Increment</li> <li>• Time_Delay</li> <li>• Notification_Class</li> <li>• High_Limit</li> <li>• Low_Limit</li> <li>• Deadband</li> <li>• Limit_Enable</li> <li>• Event_Enable</li> <li>• Notify_Type</li> </ul>	<ul style="list-style-type: none"> <li>• Description</li> <li>• Reliability</li> <li>• Priority_Array</li> <li>• Relinquish_Default</li> <li>• COV_Increment</li> <li>• Time_Delay</li> <li>• Notification_Class</li> <li>• High_Limit</li> <li>• Low_Limit</li> <li>• Deadband</li> <li>• Limit_Enable</li> <li>• Event_Enable</li> <li>• Acked_Transitions</li> <li>• Notify_Type</li> <li>• Event_Time_Stamps</li> </ul>	Yes	Yes, only user created objects
Binary Input	<ul style="list-style-type: none"> <li>• Object_Identifier</li> <li>• Object_Name</li> <li>• Object_Type</li> <li>• Present_Value</li> <li>• Status_Flags</li> <li>• Event_State</li> <li>• Out_Of_Service</li> <li>• Polarity</li> </ul>	<ul style="list-style-type: none"> <li>• Object_Name</li> <li>• Description</li> <li>• Out_Of_Service</li> <li>• Inactive_Text</li> <li>• Active_Text</li> <li>• Present_Value</li> <li>• Reliability</li> <li>• Change_Of_State_Count</li> <li>• Elapsed_Active_Time</li> <li>• Time_Delay</li> <li>• Notification_Class</li> <li>• Alarm_Value</li> <li>• Event_Enable</li> <li>• Acked_Transitions</li> <li>• Notify_Type</li> </ul>	<ul style="list-style-type: none"> <li>• Description</li> <li>• Inactive_Text</li> <li>• Active_Text</li> <li>• Change_Of_State_Time</li> <li>• Change_Of_State_Count</li> <li>• Time_Of_State_Count_Reset</li> <li>• Elapsed_Active_Time</li> <li>• Time_Of_Active_Time_Reset</li> <li>• Time_Delay</li> <li>• Notification_Class</li> <li>• Alarm_Value</li> <li>• Event_Enable</li> <li>• Acked_Transitions</li> <li>• Notify_Type</li> <li>• Event_Time_Stamps</li> <li>• Reliability</li> </ul>	Yes	Yes, only user created objects

## Installation - Electrical

**Table 98. Descriptions and configurations (continued)**

Object Type	Required Properties Read	Properties Written <sup>(a)</sup>	Optional Properties Read	Ability to Create	Ability to Delete
Binary Output	<ul style="list-style-type: none"> <li>Object_Identifier</li> <li>Object_Name</li> <li>Object_Type</li> <li>Present_Value</li> <li>Status_Flags</li> <li>Event_State</li> <li>Out_Of_Service</li> <li>Polarity</li> <li>Priority_Array</li> <li>Relinquish_Default</li> </ul>	<ul style="list-style-type: none"> <li>Object_Name</li> <li>Description</li> <li>Out_Of_Service</li> <li>Inactive_Text</li> <li>Active_Text</li> <li>Present_Value</li> <li>Reliability</li> <li>Change_Of_State_Count</li> <li>Elapsed_Active_Time</li> <li>Minimum_On_Time</li> <li>Minimum_Off_Time</li> <li>Relinquish_Default</li> <li>Time_Delay</li> <li>Notification_Class</li> <li>Event_Enable</li> <li>Acked_Transitions</li> <li>Notify_Type</li> </ul>	<ul style="list-style-type: none"> <li>Description</li> <li>Inactive_Text</li> <li>Active_Text</li> <li>Change_Of_State_Time</li> <li>Change_Of_State_Count</li> <li>Time_Of_State_Count_Reset</li> <li>Elapsed_Active_Time</li> <li>Time_Of_Active_Time_Reset</li> <li>Minimum_On_Time</li> <li>Minimum_Off_Time</li> <li>Time_Delay</li> <li>Notification_Class</li> <li>Feedback_Value</li> <li>Event_Enable</li> <li>Acked_Transitions</li> <li>Notify_Type</li> <li>Event_Time_Stamps</li> <li>Reliability</li> </ul>	Yes	Yes, only user created objects
Binary Value	<ul style="list-style-type: none"> <li>Object_Identifier</li> <li>Object_Name</li> <li>Object_Type</li> <li>Present_Value</li> <li>Status_Flags</li> <li>Event_State</li> <li>Out_Of_Service</li> <li>Polarity</li> </ul>	<ul style="list-style-type: none"> <li>Object_Name</li> <li>Description</li> <li>Out_Of_Service</li> <li>Inactive_Text</li> <li>Active_Text</li> <li>Present_Value</li> <li>Reliability</li> <li>Change_Of_State_Count</li> <li>Elapsed_Active_Time</li> <li>Minimum_On_Time</li> <li>Minimum_Off_Time</li> <li>Relinquish_Default</li> <li>Time_Delay</li> <li>Notification_Class</li> <li>Alarm_Value</li> <li>Event_Enable</li> <li>Acked_Transitions</li> <li>Notify_Type</li> </ul>	<ul style="list-style-type: none"> <li>Description</li> <li>Inactive_Text</li> <li>Active_Text</li> <li>Change_Of_State_Time</li> <li>Change_Of_State_Count</li> <li>Time_Of_State_Count_Reset</li> <li>Elapsed_Active_Time</li> <li>Time_Of_Active_Time_Reset</li> <li>Priority_Array</li> <li>Relinquish_Default</li> <li>Minimum_On_Time</li> <li>Minimum_Off_Time</li> <li>Time_Delay</li> <li>Notification_Class</li> <li>Alarm_Value</li> <li>Event_Enable</li> <li>Acked_Transitions</li> <li>Notify_Type</li> <li>Event_Time_Stamps</li> <li>Reliability</li> </ul>	Yes	Yes, only user created objects
Device	<ul style="list-style-type: none"> <li>Object_Identifier</li> <li>Object_Name</li> <li>Object_Type</li> <li>System_Status</li> <li>Vendor_Name</li> <li>Vendor_Identifier</li> <li>Model_Name</li> <li>Firmware_Revision</li> <li>Application_Software_Version</li> <li>Protocol_Version</li> <li>Protocol_Revision</li> <li>Protocol_Services_Supported</li> <li>Protocol_Object_Types_Supported</li> <li>Object_List</li> <li>Max_APDU_Length_Accepted</li> <li>Segmentation_Supported</li> <li>APDU_Timeout</li> <li>Number_Of_APDU_Retries</li> <li>Device_Address_Binding</li> <li>Database_Revision</li> </ul>	<ul style="list-style-type: none"> <li>Object_Name</li> <li>Location</li> <li>Description</li> <li>APDU_Segment_Timeout</li> <li>APDU_Timeout</li> <li>Number_Of_APDU_Retries</li> <li>Backup_Failure_Timeout</li> </ul>	<ul style="list-style-type: none"> <li>Location</li> <li>Description</li> <li>Max_Segments_Accepted</li> <li>APDU_Segment_Timeout</li> <li>Max_Master</li> <li>Max_Info_Frames</li> <li>Local_Time</li> <li>Local_Date</li> <li>Configuration_Files</li> <li>Last_Restore_Time</li> <li>Backup_Failure_Timeout</li> <li>Active_COV_Subscriptions</li> </ul>	None	None
Event Enrollment Object	<ul style="list-style-type: none"> <li>Object_Identifier</li> <li>Object_Name</li> <li>Object_Type</li> <li>Event_Type</li> <li>Notify_Type</li> <li>Event_Parameters</li> <li>Object_Property_Reference</li> <li>Event_State</li> <li>Event_Enable</li> <li>Acked_Transitions</li> <li>Notification_Class</li> <li>Event_Time_Stamps</li> </ul>	<ul style="list-style-type: none"> <li>Object_Name</li> <li>Notify_Type</li> <li>Event_Parameters</li> <li>Object_Property_Reference</li> <li>Event_Enable</li> <li>Notification_Class</li> </ul>	<ul style="list-style-type: none"> <li>None</li> </ul>	Yes	Yes, only user created objects

## Installation - Electrical

**Table 98. Descriptions and configurations (continued)**

Object Type	Required Properties Read	Properties Written <sup>(a)</sup>	Optional Properties Read	Ability to Create	Ability to Delete
Multistate Input	<ul style="list-style-type: none"> <li>Object_Identifier</li> <li>Object_Name</li> <li>Object_Type</li> <li>Present_Value</li> <li>Status_Flags</li> <li>Event_State</li> <li>Out_Of_Service</li> <li>Number_Of_States</li> </ul>	<ul style="list-style-type: none"> <li>Object_Name</li> <li>Description</li> <li>State_Text</li> <li>Out_Of_Service</li> <li>Present_Value</li> <li>Reliability</li> <li>Time_Delay</li> <li>Notification_Class</li> <li>Alarm_Values</li> <li>Fault_Values</li> <li>Event_Enable</li> <li>Notify_Type</li> </ul>	<ul style="list-style-type: none"> <li>State_Text</li> <li>Reliability</li> <li>Time_Delay</li> <li>Notification_Class</li> <li>Alarm_Values</li> <li>Fault_Values</li> <li>Event_Enable</li> <li>Acked_Transitions</li> <li>Notify_Type</li> <li>Event_Time_Stamps</li> </ul>	Yes	Yes, only user created objects
Multistate Output	<ul style="list-style-type: none"> <li>Object_Identifier</li> <li>Object_Name</li> <li>Object_Type</li> <li>Present_Value</li> <li>Status_Flags</li> <li>Event_State</li> <li>Out_Of_Service</li> <li>Number_Of_States</li> <li>Priority_Array</li> <li>Relinquish Default</li> </ul>	<ul style="list-style-type: none"> <li>Object_Name</li> <li>Description</li> <li>State_Text</li> <li>Out_Of_Service</li> <li>Present_Value</li> <li>Reliability</li> <li>Time_Delay</li> <li>Notification_Class</li> <li>Event_Enable</li> <li>Notify_Type</li> </ul>	<ul style="list-style-type: none"> <li>State_Text</li> <li>Reliability</li> <li>Relinquish_Default</li> <li>Time_Delay</li> <li>Notification_Class</li> <li>Feedback_Values</li> <li>Event_Enable</li> <li>Acked_Transitions</li> <li>Notify_Type</li> <li>Event_Time_Stamps</li> </ul>	Yes	Yes, only user created objects
Multistate Value	<ul style="list-style-type: none"> <li>Object_Identifier</li> <li>Object_Name</li> <li>Object_Type</li> <li>Present_Value</li> <li>Status_Flags</li> <li>Event_State</li> <li>Out_Of_Service</li> <li>Number_Of_States</li> </ul>	<ul style="list-style-type: none"> <li>Object_Name</li> <li>Description</li> <li>State_Text</li> <li>Out_Of_Service</li> <li>Present_Value</li> <li>Reliability</li> <li>Priority_Array</li> <li>Relinquish_Default</li> <li>Time_Delay</li> <li>Notification_Class</li> <li>Alarm_Values</li> <li>Fault_Values</li> <li>Event_Enable</li> <li>Notify_Type</li> </ul>	<ul style="list-style-type: none"> <li>State_Text</li> <li>Reliability</li> <li>Relinquish_Default</li> <li>Time_Delay</li> <li>Notification_Class</li> <li>Alarm_Values</li> <li>Fault_Values</li> <li>Event_Enable</li> <li>Acked_Transitions</li> <li>Notify_Type</li> <li>Event_Time_Stamps</li> </ul>	Yes	Yes, only user created objects
Notification Class	<ul style="list-style-type: none"> <li>Object_Identifier</li> <li>Object_Name</li> <li>Object_Type</li> <li>Notification_Class</li> <li>Priority</li> <li>Ack_Required</li> <li>Recipient_List</li> </ul>	<ul style="list-style-type: none"> <li>Object_Name</li> <li>Priority</li> <li>Ack_Required</li> <li>Recipient_List</li> </ul>	None	Yes	Yes, only user created objects
Trend	<ul style="list-style-type: none"> <li>Object_Identifier</li> <li>Object_Name</li> <li>Object_Type</li> <li>Log_Enable</li> <li>Stop_When_Full</li> <li>Buffer_Size</li> <li>Log_Buffer</li> <li>Record_Count</li> <li>Total_Record_Count</li> <li>Event_State</li> </ul>	<ul style="list-style-type: none"> <li>Object_Name</li> <li>Log_Enable</li> <li>Start_Time</li> <li>Stop_Time</li> <li>Log_DeviceObjectProperty</li> <li>Log_Interval</li> <li>Stop_When_Full</li> <li>Buffer_Size</li> <li>Log_Buffer</li> <li>Record_Count</li> <li>Notification_Threshold</li> <li>Notification_Class</li> <li>Event_Enable</li> <li>Notify_Type</li> </ul>	<ul style="list-style-type: none"> <li>Start_Time</li> <li>Stop_Time</li> <li>Log_DeviceObjectProperty</li> <li>Log_Interval</li> <li>Stop_When_Full</li> <li>Buffer_Size</li> <li>Notification_Threshold</li> <li>Records_Since_Notification</li> <li>Last_Notify_Record</li> <li>Notification_Class</li> <li>Event_Enable</li> <li>Acked_Transitions</li> <li>Event_Time_Stamps</li> </ul>	Yes	Yes, only user created objects

**(a) Properties written for Present\_Value and Reliability only if Out\_of\_Service is TRUE.**

### BACnet Protocol

#### Data Link Layer Options

Data Link Layer Description	Supported Option
ANSI/ATA 878.1, 2.5 Mb ARCNET (Clause 8)	
ANSI/ATA 878.1, RS-485 ARCNET (Clause 8), Baud Rate(s)	
BACnet IP, (Annex J)	
BACnet IP, (Annex J), Foreign Device	

ISO 8802-3, Ethernet (Clause 7)(10Base2, 10Base5, 10BaseT, Fiber)

LonTalk, (Clause 11), Medium

MS/TP Master (Clause 9), Baud Rate(s): 9600, 19200, 38400, 76800, and 115200 @1.5% Nominal ü Baud Rate

MS/TP Slave (Clause 9), Baud Rate(s)

Other

Point-to-Point, EIA 232 (Clause 10), Baud Rate(s): 9600, 19200, 38400

Point-to-Point, Modem (Clause 10), Baud Rate(s): 9600, 19200, 38400



## Installation - Electrical

### Device Address Binding

Device Address Binding	Supported?
Static Device Binding Supported	ü

### Networking Options

Networking Descriptions	Supported Option
Annex H, BACnet Tunneling	
BACnet/IP Broadcast Management Device (BBMD)	
Does the BBMD Support Registrations by Foreign Devices?	
Router	

### Character Sets

Indicates support for multiple character sets, but does not imply that all character sets are supported simultaneously. Maximum supported string length is 64 bytes (any character set).

Character Set Descriptions	Supported
ANSI X3.4	ü
IBM/Microsoft DBCS	
ISO 10646 (UCS-4)	
ISO 10646 (UCS2)	ü
ISO 8859-1	ü
JIS C 6226	

### Object Data Points and Diagnostic Data Points with Corresponding Chiller Models

For quick reference, the following tables are listed two different ways. [Table 99](#) through [Table 104](#) are listed by input/output type and sorted by object identifier. These tables provide the user with the units type for each object type. [Table 105](#) is sorted by object name and provides a complete list of object names, types, values/ranges, and descriptions. Not all points are available to the user. The available data points are defined during self-configuration and are dependent on the type of equipment

Table 99. Analog output

Object Identifier	Object Name	Description	Units	Valid Range	Relinq Default
Analog Output 1	Chilled Water Setpoint	Desired leaving water temperature if chiller is in cooling mode.	Degrees-Fahrenheit (64)	0°F to 75°F	44°F
Analog Output 2	Current Limit Setpoint	Sets the maximum capacity that the chiller can use.	Percent (98)	0% to 120%	100%
Analog Output 4	Hot Water Setpoint	Desired leaving water temperature if chiller is in heating mode.	Degrees-Fahrenheit (64)	80°F to 140°F	120°F

Table 100. Analog Input

Object Identifier	Object Name	Description	Units
Analog Input, 1	Active Cool (Heat Setpoint Temperature	Active chiller water or hot water setpoint.	Degrees-Fahrenheit (64)
Analog Input, 2	Active Current Limit Setpoint	Active capacity current limit setpoint.	Percent (98)
Analog Input, 5	Actual Running Capacity	Level of capacity that the chiller is currently running at.	Percent (98)
Analog Input, 7	Suction Pressure- Ckt 1	Circuit 1 suction pressure.	PSI
Analog Input, 10	Suction Pressure- Ckt 2	Circuit 2 suction pressure.	PSI
Analog Input, 12	Evaporator Saturated Refrigerant Temperature- Ckt 1	Circuit 2 evaporator refrigerant temperature.	Degrees-Fahrenheit (64)
Analog Input, 14	Evaporator Saturated Refrigerant Temperature- Ckt 2	Circuit 2 evaporator refrigerant temperature.	Degrees-Fahrenheit (64)
Analog Input, 16	Condenser Refrigerant Pressure- Ckt 1	Circuit 1 condenser refrigerant pressure.	PSI
Analog Input, 18	Condenser Refrigerant Pressure- Ckt 2	Circuit 2 condenser refrigerant pressure.	PSI
Analog Input, 20	Condenser Saturated Refrigerant Temperature- Ckt 1	Circuit 1 condenser refrigerant temperature.	Degrees-Fahrenheit (64)
Analog Input, 22	Condenser Saturated Refrigerant Temperature- Ckt 2	Circuit 2 condenser refrigerant temperature.	Degrees-Fahrenheit (64)

## Installation - Electrical

**Table 100. Analog Input (continued)**

Object Identifier	Object Name	Description	Units
Analog Input, 24	Unit Power Consumption	The power being consumed by the chiller.	Kilowatts
Analog Input, 25	Local Atmospheric Pressure	Local atmospheric pressure.	PSI
Analog Input, 26	Starts-Compressor 1A	Number of starts for compressor 1A.	None
Analog Input, 27	Starts-Compressor 1B	Number of starts for compressor 1B.	None
Analog Input, 28	Starts-Compressor 2A	Number of starts for compressor 2A.	None
Analog Input, 29	Starts-Compressor 2B	Number of starts for compressor 2B.	None
Analog Input, 34	Run Time-Compressor 1A	Total run time of compressor 1A.	Hours
Analog Input, 35	Run Time-Compressor 1B	Total run time of compressor 1B.	Hours
Analog Input, 36	Run Time-Compressor 2A	Total run time of compressor 2A.	Hours
Analog Input, 37	Run Time-Compressor 2B	Total run time of compressor 2B.	Hours
Analog Input, 42	Airflow Percentage-Circuit 1	Approximate airflow percentage of circuit 1.	Percent (98)
Analog Input, 43	Airflow Percentage-Circuit 2	Approximate airflow percentage of circuit 2.	Percent (98)
Analog Input, 44	Evaporator Entering Water Temp	Temperature of the water entering the evaporator.	Degrees-Fahrenheit (64)
Analog Input, 45	Evaporator Leaving Water Temp	Temperature of the water leaving the evaporator.	Degrees-Fahrenheit (64)
Analog Input, 46	Condenser Entering Water Temp	Temperature of the water entering the condenser.	Degrees-Fahrenheit (64)
Analog Input, 47	Condenser Leaving Water Temp	Temperature of the water leaving the condenser.	Degrees-Fahrenheit (64)
Analog Input, 48	High Side Oil Pressure-Compressor 1A	Pressure of the oil at the high side of compressor 1A.	PSI
Analog Input, 49	High Side Oil Pressure-Compressor 1B	Pressure of the oil at the high side of compressor 1B.	PSI
Analog Input, 50	High Side Oil Pressure-Compressor 2A	Pressure of the oil at the high side of compressor 2A.	PSI
Analog Input, 51	High Side Oil Pressure-Compressor 2B	Pressure of the oil at the high side of compressor 2B.	PSI
Analog Input, 56	Refrigerant Disch Temp-Ckt 1	Temperature of the refrigerant being discharged from Ckt 1.	Degrees-Fahrenheit (64)
Analog Input, 57	Outdoor Air Temperature	Outdoor air temperature.	Degrees-Fahrenheit (64)

**Table 100. Analog Input (continued)**

Object Identifier	Object Name	Description	Units
Analog Input, 58	Condenser Control Output	Percentage of condenser water flow being requested by the chiller.	Percent (98)
Analog Input, 59	Phase AB Voltage-Compressor 1A	Phase AB voltage, compressor 1A.	Volts
Analog Input, 60	Phase BC Voltage-Compressor 1A	Phase BC voltage, compressor 1A.	Volts
Analog Input, 61	Phase CA Voltage-Compressor 1A	Phase CA voltage, compressor 1A.	Volts
Analog Input, 62	Phase AB Voltage-Compressor 1B	Phase AB voltage, compressor 1B.	Volts
Analog Input, 63	Phase BC Voltage-Compressor 1B	Phase BC voltage, compressor 1B.	Volts
Analog Input, 64	Phase CA Voltage-Compressor 1B	Phase CA voltage, compressor 1B.	Volts
Analog Input, 65	Phase AB Voltage-Compressor 2A	Phase AB voltage, compressor 2A.	Volts
Analog Input, 66	Phase BC Voltage-Compressor 2A	Phase BC voltage, compressor 2A.	Volts
Analog Input, 67	Phase CA Voltage-Compressor 2A	Phase CA voltage, compressor 2A.	Volts
Analog Input, 68	Phase AB Voltage-Compressor 2B	Phase AB voltage, compressor 2B.	Volts
Analog Input, 69	Phase BC Voltage-Compressor 2B	Phase BC voltage, compressor 2B.	Volts
Analog Input, 70	Phase CA Voltage-Compressor 2B	Phase CA voltage, compressor 2B.	Volts
Analog Input, 71	Line 1 Current (in Amps)-Compressor 1A	Line 1 Current (in Amps)- Compressor 1A	Amps
Analog Input, 72	Line 2 Current (in Amps)-Compressor 1A	Line 2 Current (in Amps)- Compressor 1A	Amps
Analog Input, 73	Line 3 Current (in Amps)-Compressor 1A	Line 3 Current (in Amps)- Compressor 1A	Amps
Analog Input, 74	Line 1 Current (in Amps)-Compressor 1B	Line 1 Current (in Amps)- Compressor 1B	Amps
Analog Input, 75	Line 2 Current (in Amps)-Compressor 1B	Line 2 Current (in Amps)- Compressor 1B	Amps
Analog Input, 76	Line 3 Current (in Amps)-Compressor 1B	Line 3 Current (in Amps)- Compressor 1B	Amps
Analog Input, 77	Line 1 Current (in Amps)-Compressor 2A	Line 1 Current (in Amps)- Compressor 2A	Amps

## Installation - Electrical

**Table 100. Analog Input (continued)**

Object Identifier	Object Name	Description	Units
Analog Input, 78	Line 2 Current (in Amps)- Compressor 2A	Line 2 Current (in Amps)- Compressor 2A	Amps
Analog Input, 79	Line 3 Current (in Amps)- Compressor 2A	Line 3 Current (in Amps)- Compressor 2A	Amps
Analog Input, 80	Line 1 Current (in Amps)- Compressor 2B	Line 1 Current (in Amps)- Compressor 2B	Amps
Analog Input, 81	Line 2 Current (in Amps)- Compressor 2B	Line 2 Current (in Amps)- Compressor 2B	Amps
Analog Input, 82	Line 3 Current (in Amps)- Compressor 2B	Line 3 Current (in Amps)- Compressor 2B	Amps
Analog Input, 83	Line 1 Current (%RLA)- Compressor 1A	Line 1 Current (%RLA)- Compressor 1A	Percent (98)
Analog Input, 84	Line 2 Current (%RLA)- Compressor 1A	Line 2 Current (%RLA)- Compressor 1A	Percent (98)
Analog Input, 85	Line 3 Current (%RLA)- Compressor 1A	Line 3 Current (%RLA)- Compressor 1A	Percent (98)
Analog Input, 86	Line 1 Current (%RLA)- Compressor 1B	Line 1 Current (%RLA)- Compressor 1B	Percent (98)
Analog Input, 87	Line 2 Current (%RLA)- Compressor 1B	Line 2 Current (%RLA)- Compressor 1B	Percent (98)
Analog Input, 88	Line 3 Current (%RLA)- Compressor 1B	Line 3 Current (%RLA)- Compressor 1B	Percent (98)
Analog Input, 89	Line 1 Current (%RLA)- Compressor 2A	Line 1 Current (%RLA)- Compressor 2A	Percent (98)
Analog Input, 90	Line 2 Current (%RLA)- Compressor 2A	Line 2 Current (%RLA)- Compressor 2A	Percent (98)
Analog Input, 91	Line 3 Current (%RLA)- Compressor 2A	Line 3 Current (%RLA)- Compressor 2A	Percent (98)
Analog Input, 92	Line 1 Current (%RLA)- Compressor 2B	Line 1 Current (%RLA)- Compressor 2B	Percent (98)
Analog Input, 93	Line 2 Current (%RLA)- Compressor 2B	Line 2 Current (%RLA)- Compressor 2B	Percent (98)
Analog Input, 94	Line 3 Current (%RLA)- Compressor 2B	Line 3 Current (%RLA)- Compressor 2B	Percent (98)
Analog Input, 95	Number of Circuits	Number of Circuits	None
Analog Input, 96	Number of Compressors, Ckt 1	Number of Compressors, Ckt 1	None
Analog Input, 97	Number of Compressors, Ckt 2	Number of Compressors, Ckt 2	None

**Table 101. Multistate Output**

Object Identifier	Object Name	Description	Relinq Default	Object States
Multi-State Output, 1	Chiller Mode Command	Mode of operation of the chiller.	1 = Cool	1 = HVAC_Heat 2 = HVAC_Cool 3 = HVAC_Ice 4 = Not Used

**Table 102. Multistate Input**

BCI-C Object Identifier	Object Name	Description	Object States
Multi-State Input, 1	Running Mode	Indicates the primary running mode of the chiller.	1 = Chiller Off 2 = Chiller in Start Mode 3 = Chiller in Run Mode 4 = Chiller in Pre-shutdown Mode 5 = Chiller in Service Mode
Multi-State Input, 2	Operating Mode	Indicates the primary operating mode of the chiller.	1 = HVAC_Heat 2 = HVAC_Cool 3 = HVAC_Ice 4 = Not Used
Multi-State Input, 3	MP Comm Status	Communication status.	1 = R-22 2 = Communication 3 = Communication Lost 4 = Failed to Established 5 = Waiting to Establish
Multi-State Input, 4	Refrig Type	Refrigerant type.	1 = R-11 2 = R-12 3 = R-22 4 = R-123 5 = R-134A 6 = R407C 7 = R-410A
Multi-State Input, 5	Model Info	Indicates the model type of the chiller.	1 = RTA 2 = CVH 3 = CVG 4 = CVR 5 = CDH 6 = RTH 7 = CGW 8 = CGA 9 = CCA 10 = RTW 11 = RTX 12 = RTU 13 = CCU 14 = CXA 15 = CGC 16 = RAU



## Installation - Electrical

**Table 102. Multistate Input (continued)**

BCI-C Object Identifier	Object Name	Description	Object States
Multi-State Input, 6	Cooling Type	Cooling type of the condenser.	1 = Water Cooled 2 = Air Cooled
Multi-State Input, 7	Manuf Location	Location where chiller was manufactured.	1 = Field Applied 2 = La Crosse 3 = Pueblo 4 = Charmes 5 = Rushville 6 = Macon 7 = Waco 8 = Lexington 9 = Forsyth 10 = Clarksville 11 = Ft. Smith 12 = Penang 13 = Colchester 14 = Curitiba 15 = Taicang 16 = Taiwan 17 = Epinal 18 = Golbey

**Table 103. Binary Output**

Object Identifier	Object Name	Description	Relinq Default	Object States
Binary Output, 1	Chiller Auto Stop Command	Allows the chiller to run if conditions for running are met.	True	Inactive = Stop Active = Auto
Binary Output, 2	Remote Diagnostic Reset Command	Resets remotely diagnostics that can be reset.	False	Inactive = No Reset Request Active = Reset Request
Binary Output, 4	Noise Reduction Request	Requests chiller to enter mode to reduce noise.	False	Inactive = Normal Active = Reduced Noise

**Table 104. Binary Input**

Object Identifier	Object Name	Description	Object States
Binary Input, 1	Run Enabled	Indicates if the chiller is available to run or is currently running.	Inactive = Stop Active = Auto
Binary Input, 2	Local Setpoint Control	Indicates if the chiller is being controlled by local setpoints instead of BAS setpoints.	Inactive = Remote Control Active = Local Control
Binary Input, 3	Capacity Limited	Indicates if conditions may exist that prevent the chiller from reaching setpoint.	Inactive = Not Limited Active = Limited

**Table 104. Binary Input (continued)**

Object Identifier	Object Name	Description	Object States
Binary Input, 4	Chiller Running State	Indicates if the chiller is running or stopped.	Inactive = Off Active = On
Binary Input, 5	Condenser Water Flow Status	Condenser water flow status.	Inactive = No Flow Active = Flow
Binary Input, 6	Maximum Capacity	Indicates if all available chiller capacity is being used.	Inactive = Off Active = On
Binary Input, 7	Head Relief Request	Indicates if the chiller is asking an outside system to provide more heat rejection from the condenser water loop.	Inactive = Off Active = On
Binary Input, 9	Compr 1A Running	Indicates if compressor 1A is running.	Inactive = Off Active = Running
Binary Input, 10	Compr 1B Running	Indicates if compressor 1B is running.	Inactive = Off Active = Running
Binary Input, 11	Compr 2A Running	Indicates if compressor 2A is running.	Inactive = Off Active = Running
Binary Input, 12	Compr 2B Running	Indicates if compressor 2B is running.	Inactive = Off Active = Running
Binary Input, 17	Evaporator Water Pump Request	Indicates a request from the chiller to turn on the evaporator water pump.	Inactive = Off Active = On
Binary Input, 19	Condenser Water Pump Request	Indicates a request from the chiller to turn on the condenser water pump.	Inactive = Off Active = On
Binary Input, 20	Noise Reduction Active	Indicates if the chiller is in a state where noise is being reduced.	Inactive = Off Active = On
Binary Input, 22	Evaporator Water Flow Status	Indicates if water is flowing through the evaporator.	Inactive = No Flow Active = Flow
Binary Input, 23	Alarm Present	Indicates if an alarm is active.	Inactive = No Alarm Active = Alarm
Binary Input, 24	Shutdown Alarm Present	Indicates if a shutdown alarm is active.	Inactive = No Alarm Active = None
Binary Input, 25	Last Diagnostic	Indicates last diagnostic for the chiller.	Inactive = Off Active = On

**Table 105. All ObjectTypes Sorted by Object Name (Refer to previous tables for detailed descriptions of objects)**

Object Identifier <sup>(a)</sup>	Object Name	Description
Analog Output 1	Chilled Water Setpoint	Desired leaving water temperature if chiller is in cooling mode.
Analog Output 2	Current Limit Setpoint	Sets the maximum capacity that the chiller can use.
Analog Output 4	Hot Water Setpoint	Desired leaving water temperature if chiller is in heating mode.
Analog Input, 1	Active Cool/Heat Setpoint Temperature	Active chiller water or hot water setpoint.
Analog Input, 2	Active Current Limit Setpoint	Active capacity current limit setpoint.
Analog Input, 5	Actual Running Capacity	Level of capacity that the chiller is currently running at.
Analog Input, 7	Suction Pressure-Ckt 1	Circuit 1 suction pressure.
Analog Input, 10	Suction Pressure-Ckt 2	Circuit 2 suction pressure.
Analog Input, 12	Evaporator Saturated Refrigerant Temperature- Ckt 1	Circuit 2 evaporator refrigerant temperature.
Analog Input, 14	Evaporator Saturated Refrigerant Temperature- Ckt 2	Circuit 2 evaporator refrigerant temperature.
Analog Input, 16	Condenser Refrigerant Pressure- Ckt 1	Circuit 1 condenser refrigerant pressure.
Analog Input, 18	Condenser Refrigerant Pressure- Ckt 2	Circuit 2 condenser refrigerant pressure.
Analog Input, 20	Condenser Saturated Refrigerant Temperature- Ckt 1	Circuit 1 condenser refrigerant temperature.
Analog Input, 22	Condenser Saturated Refrigerant Temperature- Ckt 2	Circuit 2 condenser refrigerant temperature.
Analog Input, 24	Unit Power Consumption	The power being consumed by the chiller.
Analog Input, 25	Local Atmospheric Pressure	Local atmospheric pressure.
Analog Input, 26	Starts-Compressor 1A	Number of starts for compressor 1A.
Analog Input, 27	Starts-Compressor 1B	Number of starts for compressor 1B.
Analog Input, 28	Starts-Compressor 2A	Number of starts for compressor 2A.
Analog Input, 29	Starts-Compressor 2B	Number of starts for compressor 2B.
Analog Input, 34	Run Time-Compressor 1A	Total run time of compressor 1A.

**Table 105. All ObjectTypes Sorted by Object Name (Refer to previous tables for detailed descriptions of objects)**

Object Identifier <sup>(a)</sup>	Object Name	Description
Analog Input, 35	Run Time-Compressor 1B	Total run time of compressor 1B.
Analog Input, 36	Run Time-Compressor 2A	Total run time of compressor 2A.
Analog Input, 37	Run Time-Compressor 2B	Total run time of compressor 2B.
Analog Input, 42	Airflow Percentage- Circuit 1	Approximate airflow percentage of circuit 1.
Analog Input, 43	Airflow Percentage- Circuit 2	Approximate airflow percentage of circuit 2.
Analog Input, 44	Evaporator Entering Water Temp	Temperature of the water entering the evaporator.
Analog Input, 45	Evaporator Leaving Water Temp	Temperature of the water leaving the evaporator.
Analog Input, 46	Condenser Entering Water Temp	Temperature of the water entering the condenser.
Analog Input, 47	Condenser Leaving Water Temp	Temperature of the water leaving the condenser.
Analog Input, 48	High Side Oil Pressure-Compressor 1A	Pressure of the oil at the high side of compressor 1A.
Analog Input, 49	High Side Oil Pressure-Compressor 1B	Pressure of the oil at the high side of compressor 1B.
Analog Input, 50	High Side Oil Pressure-Compressor 2A	Pressure of the oil at the high side of compressor 2A.
Analog Input, 51	High Side Oil Pressure-Compressor 2B	Pressure of the oil at the high side of compressor 2B.
Analog Input, 56	Refrigerant Disch Temp- Ckt 1	Temperature of the refrigerant being discharged from Ckt 1.
Analog Input, 57	Outdoor Air Temperature	Outdoor air temperature.
Analog Input, 58	Condenser Control Output	Percentage of condenser water flow being requested by the chiller.
Analog Input, 59	Phase AB Voltage-Compressor 1A	Phase AB voltage, compressor 1A.
Analog Input, 60	Phase BC Voltage-Compressor 1A	Phase BC voltage, compressor 1A.
Analog Input, 61	Phase CA Voltage-Compressor 1A	Phase CA voltage, compressor 1A.
Analog Input, 62	Phase AB Voltage-Compressor 1B	Phase AB voltage, compressor 1B.
Analog Input, 63	Phase BC Voltage-Compressor 1B	Phase BC voltage, compressor 1B.
Analog Input, 64	Phase CA Voltage-Compressor 1B	Phase CA voltage, compressor 1B.
Analog Input, 65	Phase AB Voltage-Compressor 2A	Phase AB voltage, compressor 2A.
Analog Input, 66	Phase BC Voltage-Compressor 2A	Phase BC voltage, compressor 2A.
Analog Input, 67	Phase CA Voltage-Compressor 2A	Phase CA voltage, compressor 2A.

## Installation - Electrical

**Table 105. All ObjectTypes Sorted by Object Name (Refer to previous tables for detailed descriptions of objects)**

Object Identifier <sup>(a)</sup>	Object Name	Description
Analog Input, 68	Phase AB Voltage-Compressor 2B	Phase AB voltage, compressor 2B.
Analog Input, 69	Phase BC Voltage-Compressor 2B	Phase BC voltage, compressor 2B.
Analog Input, 70	Phase CA Voltage-Compressor 2B	Phase CA voltage, compressor 2B
Analog Input, 71	Line 1 Current (in Amps)-Compressor 1A	Line 1 Current (in Amps)-Compressor 1A
Analog Input, 72	Line 2 Current (in Amps)-Compressor 1A	Line 2 Current (in Amps)-Compressor 1A
Analog Input, 73	Line 3 Current (in Amps)-Compressor 1A	Line 3 Current (in Amps)-Compressor 1A
Analog Input, 74	Line 1 Current (in Amps)-Compressor 1B	Line 1 Current (in Amps)-Compressor 1B
Analog Input, 75	Line 2 Current (in Amps)-Compressor 1B	Line 2 Current (in Amps)-Compressor 1B
Analog Input, 76	Line 3 Current (in Amps)-Compressor 1B	Line 3 Current (in Amps)-Compressor 1B
Analog Input, 77	Line 1 Current (in Amps)-Compressor 2A	Line 1 Current (in Amps)-Compressor 2A
Analog Input, 78	Line 2 Current (in Amps)-Compressor 2A	Line 2 Current (in Amps)-Compressor 2A
Analog Input, 79	Line 3 Current (in Amps)-Compressor 2A	Line 3 Current (in Amps)-Compressor 2A
Analog Input, 80	Line 1 Current (in Amps)-Compressor 2B	Line 1 Current (in Amps)-Compressor 2B
Analog Input, 81	Line 2 Current (in Amps)-Compressor 2B	Line 2 Current (in Amps)-Compressor 2B
Analog Input, 82	Line 3 Current (in Amps)-Compressor 2B	Line 3 Current (in Amps)-Compressor 2B
Analog Input, 83	Line 1 Current (%RLA)-Compressor 1A	Line 1 Current (%RLA)- Compressor 1A
Analog Input, 84	Line 2 Current (%RLA)-Compressor 1A	Line 2 Current (%RLA)- Compressor 1A
Analog Input, 85	Line 3 Current (%RLA)-Compressor 1A	Line 3 Current (%RLA)- Compressor 1A
Analog Input, 86	Line 1 Current (%RLA)-Compressor 1B	Line 1 Current (%RLA)- Compressor 1B
Analog Input, 87	Line 2 Current (%RLA)-Compressor 1B	Line 2 Current (%RLA)- Compressor 1B
Analog Input, 88	Line 3 Current (%RLA)-Compressor 1B	Line 3 Current (%RLA)- Compressor 1B

**Table 105. All ObjectTypes Sorted by Object Name (Refer to previous tables for detailed descriptions of objects)**

Object Identifier <sup>(a)</sup>	Object Name	Description
Analog Input, 89	Line 1 Current (%RLA)-Compressor 2A	Line 1 Current (%RLA)- Compressor 2A
Analog Input, 90	Line 2 Current (%RLA)-Compressor 2A	Line 2 Current (%RLA)- Compressor 2A
Analog Input, 91	Line 3 Current (%RLA)-Compressor 2A	Line 3 Current (%RLA)- Compressor 2A
Analog Input, 92	Line 1 Current (%RLA)-Compressor 2B	Line 1 Current (%RLA)- Compressor 2B
Analog Input, 93	Line 2 Current (%RLA)-Compressor 2B	Line 2 Current (%RLA)- Compressor 2B
Analog Input, 94	Line 3 Current (%RLA)-Compressor 2B	Line 3 Current (%RLA)- Compressor 2B
Analog Input, 95	Number of Circuits	Number of Circuits
Analog Input, 96	Number of Compressors, Ckt 1	Number of Compressors, Ckt 1
Analog Input, 97	Number of Compressors, Ckt 2	Number of Compressors, Ckt 2
Multi-State Input, 1	Running Mode	Indicates the primary running mode of the chiller.
Multi-State Input, 2	Operating Mode	Indicates the primary operating mode of the chiller.
Multi-State Input, 3	MP Communication Status	Communication status.
Multi-State Input, 4	Refrigerant Type	Refrigerant type.
Multi-State Input, 5	Model Information	Indicates the model type of the chiller.
Multi-State Input, 6	Cooling Type	Cooling type of the condenser.
Multi-State Input, 7	Manufacturing Location	Location where chiller was manufactured.
Binary Output, 1	Chiller Auto Stop Command	Allows the chiller to run if conditions for running are met.
Binary Output, 2	Remote Diagnostic Reset Command	Resets remotely diagnostics that can be reset.
Binary Output, 4	Noise Reduction Request	Requests chiller to enter mode to reduce noise.
Binary Output, 1	Chiller Auto Stop Command	Allows the chiller to run if conditions for running are met.
Binary Input, 1	Run Enabled	Indicates if the chiller is available to run or is currently running.
Binary Input, 2	Local Setpoint Control	Indicates if the chiller is being controlled by local setpoints instead of BAS setpoints.

## Installation - Electrical

**Table 105. All Object Types Sorted by Object Name** (Refer to previous tables for detailed descriptions of objects)

Object Identifier <sup>(a)</sup>	Object Name	Description
Binary Input, 3	Capacity Limited	Indicates if conditions may exist that prevent the chiller from reaching setpoint.
Binary Input, 4	Chiller Running State	Indicates if the chiller is running or stopped.
Binary Input, 5	Condenser Water Flow Status	Condenser water flow status.
Binary Input, 6	Maximum Capacity	Indicates if all available chiller capacity is being used.
Binary Input, 7	Head Relief Request	Indicates if the chiller is asking an outside system to provide more heat
Binary Input, 9	Compressor 1A Running	Indicates if compressor 1A is running.
Binary Input, 10	Compressor 1B Running	Indicates if compressor 1B is running.
Binary Input, 11	Compressor 2A Running	Indicates if compressor 2A is running.
Binary Input, 12	Compressor 2B Running	Indicates if compressor 2B is running.
Binary Input, 17	Evaporator Water Pump Request	Indicates a request from the chiller to turn on the evaporator water pump.
Binary Input, 19	Condenser Water Pump Request	Indicates a request from the chiller to turn on the condenser water pump.
Binary Input, 20	Noise Reduction Active	Indicates if the chiller is in a state where noise is being reduced.
Binary Input, 22	Evaporator Water Flow Status	Indicates if water is flowing through the evaporator.
Binary Input, 23	Alarm Present	Indicates if an alarm is active.
Binary Input, 24	Shutdown Alarm Present	Indicates if a shutdown alarm is present.
Binary Input, 25	Last Diagnostic	Indicates the last diagnostic for the chiller.

(a) AI=Analog Input, AO=Analog Output, AV=Analog Value, BI=Binary Input, BO=Binary Output, MI=Multistate Input, MO=Multistate Output

### BCI-C Alarming

The BCI-C unit has three binary input points used to communicate alarms and one binary output point used to reset alarms remotely. Those inputs and output points are:

**BI 23; Alarm Present.** •This object indicates if any alarms are active regardless of severity. A notification will be sent to any recipients of the Information Notification Class object when the point transitions from No Alarm to Alarm.

**BI 24; Shutdown Alarm Present.** •This object indicates if any alarms that result in the shutdown of the chiller are active. A notification will be sent to any recipients of the Critical Notification Class object when the point transitions from No Alarm to Alarm.

**BI 25; Last Diagnostic.** •The active text of this object will reflect the description of the last diagnostic to occur on the chiller.

**BO 2; Remote Diagnostic Reset Command.** •This object is used to remotely reset diagnostics on the chiller. Immediately after commanding this point value to 1, the BCI-C will send the reset command to the chiller and set this point value back to 0 and clear the priority array.

Note: Not all diagnostics are able to be reset remotely. Some will require local reset at the chiller front panel.

# RTWD/RTUD Operating Principles

This section contains an overview of the operation of RTWD Series R chillers equipped with microcomputer-based control systems. It describes the overall operating principles of the RTWD water chiller.

Note: To ensure proper diagnosis and repair, contact a qualified service organization if a problem should occur.

## General

### RTWD

The Model RTWD units are dual-compressor, dual circuit, water-cooled liquid chillers. These units are equipped with unit-mounted starter/control panels. The basic components of an RTWD unit are:

- Unit-mounted panel containing starter and Tracer CH530 controller and Input/Output LLIDS
- Helical-rotary compressors
- Evaporator
- Condenser
- Electronic expansion valves
- Water-cooled condenser with integral subcooler
- Oil supply system
- Oil cooler (application dependent)
- Related interconnecting piping.

### RTUD

The Model RTUD units are dual compressor, dual circuit compressor chillers. These units are equipped with unit mounted starter/control panel. The basic components of an RTUD unit are:

- Unit-mounted panel containing starter and tracer CH530 controller and Input/Output LLIDs
- Helical-rotary compressors
- Evaporator
- Electronic expansion valves
- Oil supply system
- Oil cooler
- Related interconnecting piping

Components of a typical unit are identified in [Figure 46](#) and [Figure 47](#), p. 126.

#### **⚠ WARNING**

#### **Refrigerant under High Pressure! (RTWD Only)**

**System contains oil and refrigerant under high pressure. Recover refrigerant to relieve pressure before opening the system. See unit nameplate for refrigerant type. Do not use non-approved refrigerants, refrigerant substitutes, or refrigerant additives. Failure to recover refrigerant to relieve pressure or the use of non-approved refrigerants, refrigerant substitutes, or refrigerant additives could result in an explosion which could result in death or serious injury or equipment damage.**

#### **⚠ WARNING**

#### **Hazardous Voltage!**

**Disconnect all electric power, including remote disconnects before servicing. Follow proper lockout/tagout procedures to ensure the power can not be inadvertently energized. Failure to disconnect power before servicing could result in death or serious injury.**

**Figure 46. RTWD/RTUD components (front view)**

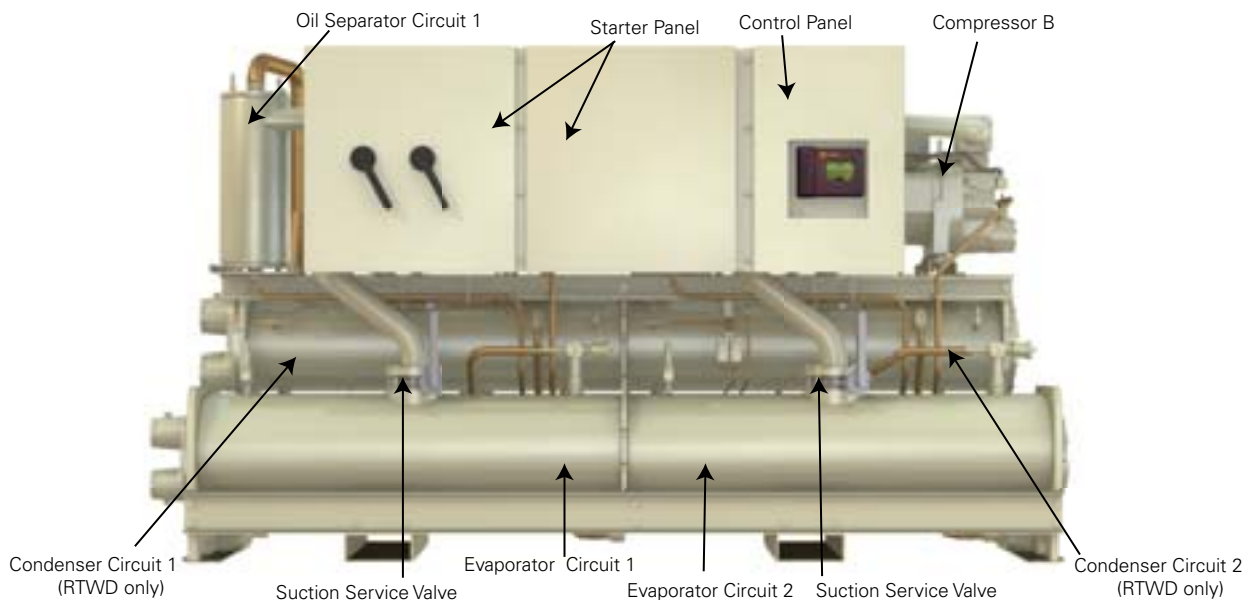

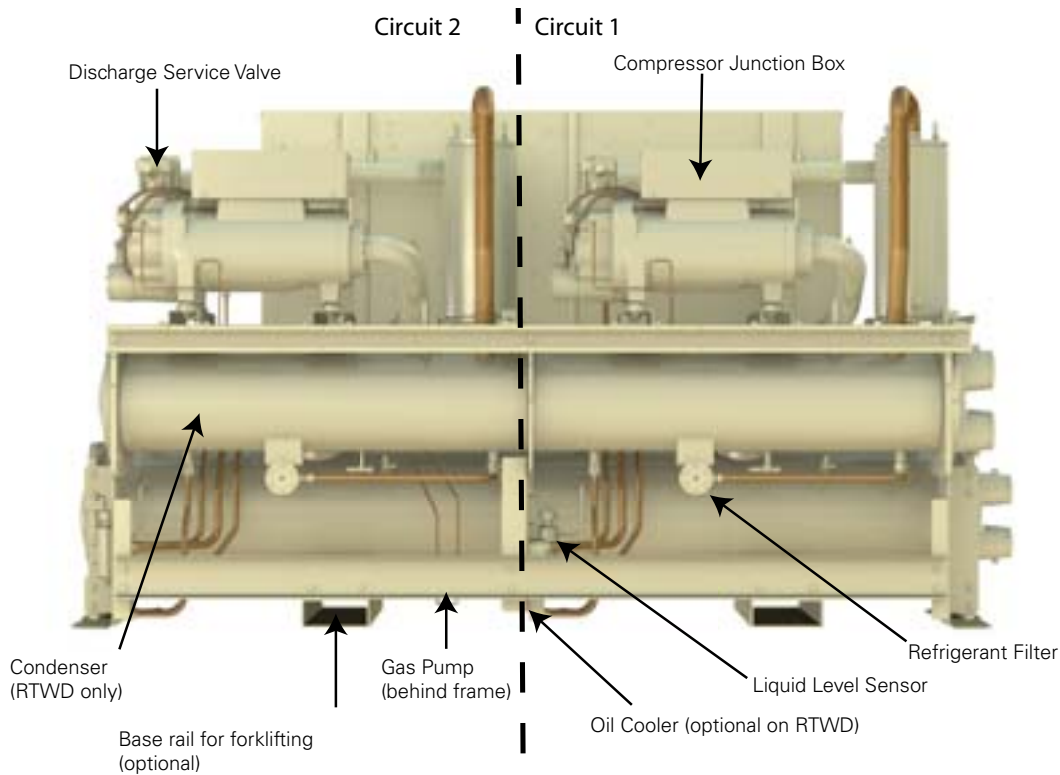
**Figure 47. RTWD/RTUD components (back view)**

## Refrigeration (Cooling) Cycle

### Overview

The refrigeration cycle of the Series R chiller is conceptually similar to that of other Trane chiller products. It makes use of a shell-and-tube evaporator design with refrigerant evaporating on the shell side and water flowing inside tubes having enhanced surfaces.

The compressor is a twin-rotor helical rotary type. It uses a suction gas-cooled motor that operates at lower motor temperatures under continuous full and part load operating conditions. An oil management system provides an almost oil-free refrigerant to the shells to maximize heat transfer performance, while providing lubrication and rotor sealing to the compressor. The lubrication system ensures long compressor life and contributes to quiet operation.

For RTWD units, condensing is accomplished in a shell-and-tube heat exchanger where refrigerant is condensed on the shell side and water flows internally in the tubes.

For RTUD units, condensing is accomplished in a remote air-cooled condenser unit. The refrigerant flows through the tubes in the condenser. Air flows over the coils in the condenser, removing the heat and condensing the refrigerant.

Refrigerant is metered through the flow system using an electronic expansion valve, that maximizes chiller efficiency at part load.

A unit-mounted starter and control panel is provided on every chiller. Microprocessor-based unit control modules (Tracer CH530) provide for accurate chilled water control as well as monitoring, protection and adaptive limit functions. The “adaptive” nature of the controls intelligently prevents the chiller from operating outside of its limits, or compensates for unusual operating conditions, while keeping the chiller running rather than simply tripping due to a safety concern. When problems do occur, diagnostic messages assist the operator in troubleshooting.

### Cycle Description

The refrigeration cycle for the RTWD/RTUD chiller can be described using the pressure-enthalpy diagram shown in [Figure 48, p. 127](#). Key State Points are indicated on the figure and are referenced in the discussion following. A schematic of the system showing the refrigerant flow loop as well as the lubricant flow loop is shown in

## RTWD/RTUD Operating Principles

Figure 48. Pressure enthalpy curve

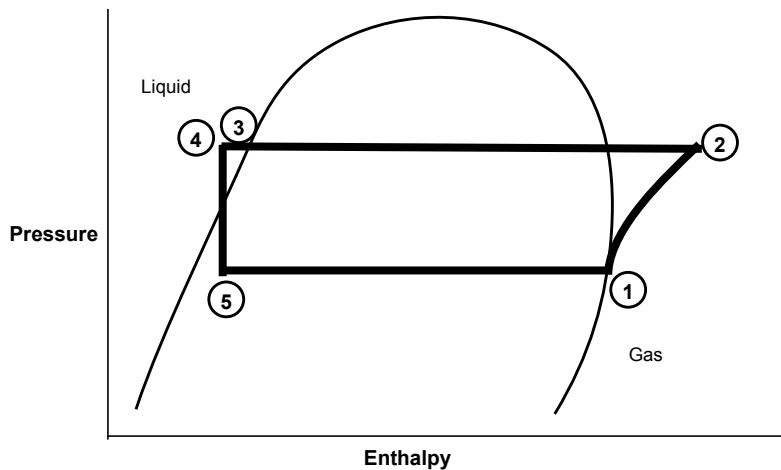

Evaporation of refrigerant occurs in the evaporator. A metered amount of refrigerant liquid enters a distribution system in the evaporator shell and is then distributed to the tubes in the evaporator tube bundle. The refrigerant absorbs heat and vaporizes as it cools the water flowing through the evaporator tubes. Refrigerant vapor leaves the evaporator as saturated vapor (State Pt. 1).

The refrigerant vapor generated in the evaporator flows to the suction end of the compressor where it enters the motor compartment of the suction-gas-cooled motor. The refrigerant flows across the motor, providing the necessary cooling, then enters the compression chamber. Refrigerant is compressed in the compressor to discharge pressure conditions. Simultaneously, lubricant is injected into the compressor for two purposes: (1) to lubricate the rolling element bearings, and (2) to seal the very small clearances between the compressor's twin rotors. Immediately following the compression process the lubricant and refrigerant are effectively divided using an oil separator. The oil-free refrigerant vapor enters the condenser at State Pt. 2. The lubrication and oil management issues are discussed in more detail in the compressor description and oil management sections that follow.

For RTWD units, a discharge baffle within the condenser shell distributes the compressed refrigerant vapor evenly across the condenser tube bundle. Cooling tower water, circulating through the condenser tubes, absorbs heat from this refrigerant and condenses it.

For RTUD units, air flows across the condenser coils, absorbing heat from the refrigerant and condenses it.

As the refrigerant enters the bottom of the condenser (State Pt. 3), it enters an integral subcooler where it is subcooled before traveling to the electronic expansion valve (State Pt. 4). The pressure drop created by the expansion process vaporizes a portion of the liquid refrigerant. The resulting mixture of liquid and gaseous refrigerant then enters the Evaporator Distribution system

(State Pt. 5). The flash gas from the expansion process is internally routed to compressor suction, and while the liquid refrigerant is distributed over the tube bundle in the evaporator.

The RTWD/RTUD chiller maximizes the evaporator heat transfer performance while minimizing refrigerant charge requirements. This is accomplished by metering the liquid refrigerant flow to the evaporator's distribution system using the electronic expansion valve. A relatively low liquid level is maintained in the evaporator shell, which contains a bit of surplus refrigerant liquid and accumulated lubricant. A liquid level measurement device monitors this level and provides feedback information to the CH530 unit controller, which commands the electronic expansion valve to reposition when necessary. If the level rises, the expansion valve is closed slightly, and if the level is dropping, the valve is opened slightly such that a steady level is maintained.

## RTWD/RTUD Operating Principles

Figure 49. RTWD/RTUD refrigerant chart

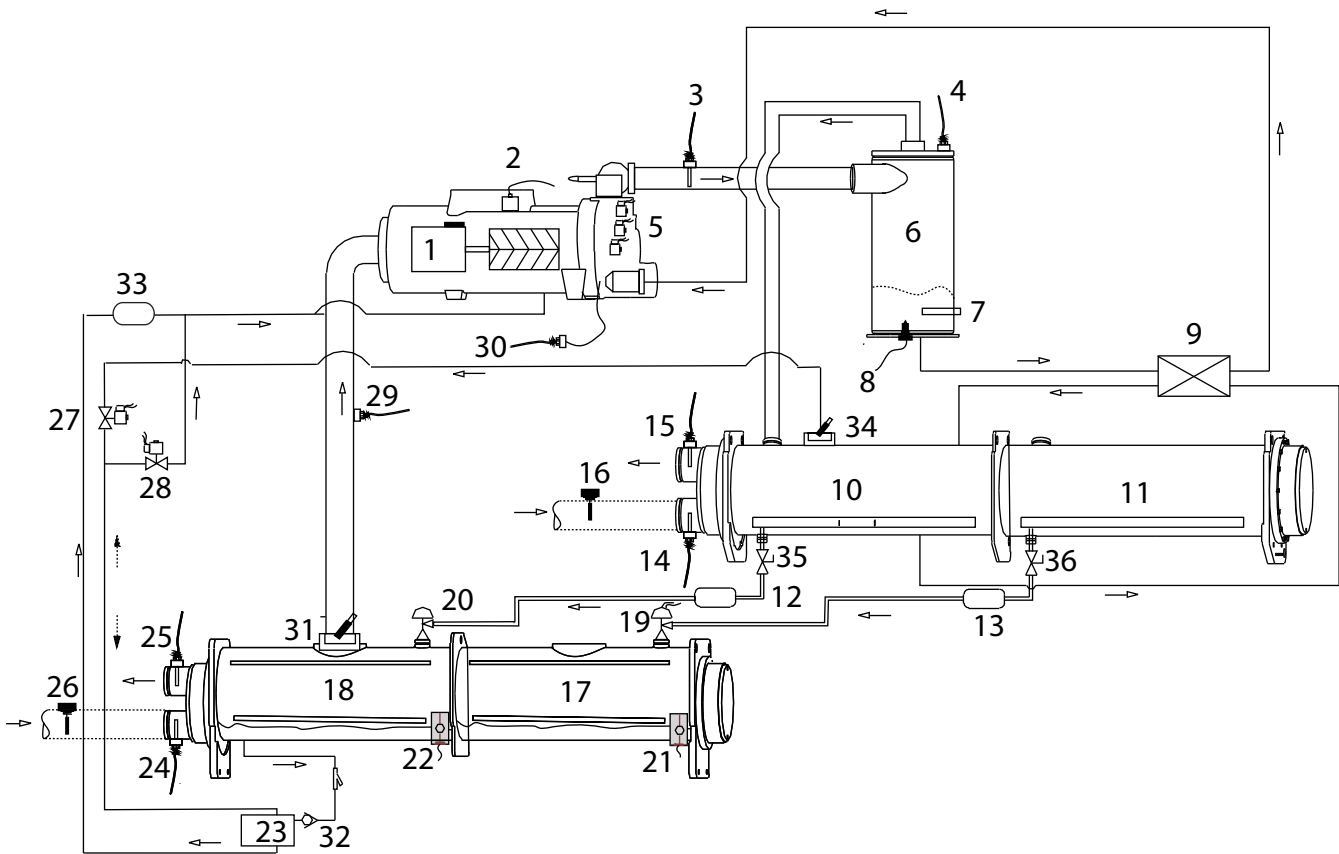

1 Compressor - Circuit 1	13 Refrigerant Filter - Circuit 2	25 Evaporator Leaving Water Temperature Sensor
2 High Pressure Cutout Switch	14 Condenser Entering Water Temperature Sensor (RTWD only)	26 Evaporator Water Flow Switch
3 Compressor Discharge Temperature Sensor	15 Condenser Leaving Water Temperature Sensor (RTWD only)	27 Gas Pump Drain Solenoid Valve
4 Condenser Refrigerant Pressure Transducer	16 Condenser Water Flow Switch (RTWD only)	28 Gas Pump Fill Solenoid Valves
5 Load/Unload and Step Solenoids	17 Evaporator - Circuit 2	29 Suction Pressure Transducer
6 Oil Separator - Circuit 1	18 Evaporator - Circuit 1	30 Oil Pressure Transducer
7 Oil Heater	19 EXV - Circuit 2	31 Suction Service Valve
8 Optical Oil Loss Level Sensor	20 EXV - Circuit 1	32 Check Valve
9 Oil Cooler (optional on RTWD)	21 Liquid Level Sensor - Circuit 2	33 Filter
10 Condenser - Circuit 1 (RTWD only)	22 Liquid Level Sensor - Circuit 1	34 Condenser Service Valve
11 Condenser - Circuit 2 (RTWD only)	23 Gas Pump - Circuit 1	35 Liquid Line Isolation Valve - Circuit 1 (RTWD only) <sup>(a)</sup>
12 Refrigerant Filter - Circuit 1	24 Evaporator Entering Water Temperature Sensor	36 Liquid Line Isolation Valve - Circuit 2 (RTWD only) <sup>(a)</sup>

(a) RTUD units do NOT ship with a factory installed liquid line isolation valve. A liquid line isolation valve must be field installed.



## RTWD/RTUD Operating Principles

### Oil System Operation (RTWD/RTUD)

#### Overview

Oil that collects in the bottom of the oil separator is at condensing pressure during compressor operation; therefore, oil is constantly moving to lower pressure areas.

As the oil leaves the separator, it passes through the oil cooler (if installed). It then goes through the service valve and filter. At this point it travels through the oil control

valve. Then it provides oil injection and bearing lubrication.

If the compressor stops for any reason, the oil control valve closes, isolating the oil charge in the separator and oil cooler during off periods. The master oil valve is a pressure activated valve. Discharge pressure off the rotors, that is developed when the compressor is on, causes the valve to open.

Figure 50. RTWD/RTUD oil system

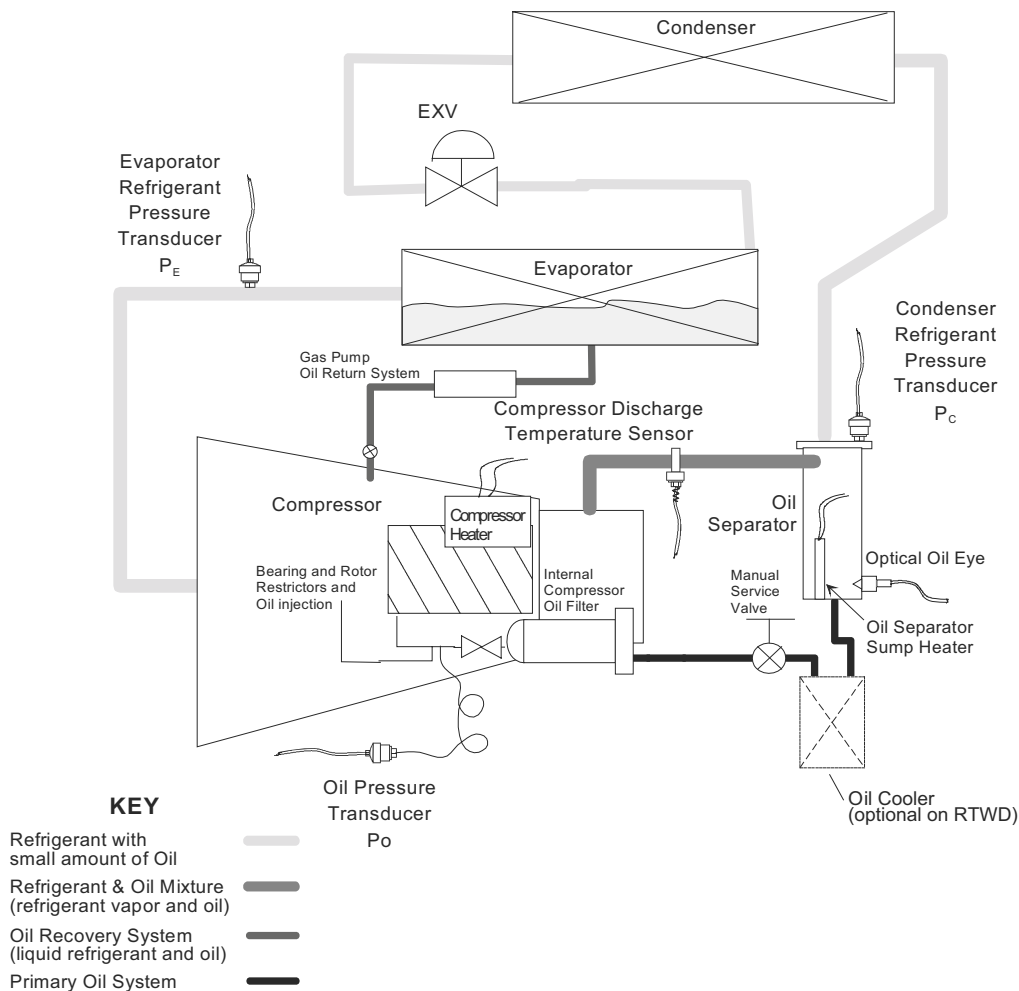

#### Compressor Motor

A two-pole, hermetic, induction motor (3600 rpm at 60 hz, 3000 rpm at 50hz) directly drives the compressor rotors. The motor is cooled by suction refrigerant gas from the evaporator, entering the end of the motor housing through the suction line.

#### Compressor Rotors

Each compressor has two rotors - "male" and "female" - which provide compression. See Figure 51, p. 130. The male rotor is attached to, and driven by, the motor, and the female rotor is, in turn, driven by the male rotor. Separately housed bearing sets are provided at each end of both rotors.

## RTWD/RTUD Operating Principles

The helical rotary compressor is a positive displacement device. The refrigerant from the evaporator is drawn into the suction opening at the end of the motor barrel, through a suction strainer screen, across the motor, and into the intake of the compressor rotor section. The gas is then compressed and discharged directly into the discharge line.

There is no physical contact between rotors and compressor housing. Rotors contact each other at the point where the driving action between male and female rotors occurs. Oil is injected along top of compressor rotor section, coating both rotors and compressor housing interior. Although this oil does provide rotor lubrication, its primary purpose is to seal the clearance spaces between rotors and compressor housing.

A positive seal between these internal parts enhances compressor efficiency by limiting leakage between the high pressure and low pressure cavities.

### Oil Filter

Each compressor is equipped with a replaceable element oil filter. The filter removes any impurities that could foul the solenoid valve orifices and compressor internal oil supply galleries. This also prevents excessive wear of compressor rotor and bearing surfaces.

### Compressor Rotor Oil Supply

Oil flows through this circuit directly from the oil filter, through the master oil valve to the top of the compressor rotor housing. There it is injected along the top of the rotors to seal clearance spaces between the rotors and the compressor housing and to lubricate the rotors.

### Compressor Bearing Oil Supply

Oil is injected into the bearing housings located at each end of both the male and female rotors. Each bearing housing is vented to compressor suction, so that oil leaving the bearings returns through the compressor rotors to the oil separator.

**Figure 51. RTWD/RTUD compressor**

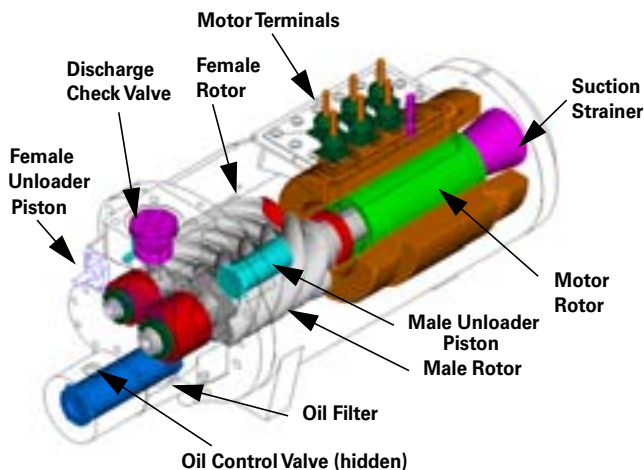

### Oil Separator

The oil separator consists of a vertical tube, joined at the top by the refrigerant discharge line from the compressor. This causes the refrigerant to swirl in the tube and throws the oil to the outside, where it collects on the walls and flows to the bottom. The compressed refrigerant vapor, stripped of oil droplets, exits out the top of the oil separator and is discharged into the condenser.

### Compressor Loading Sequence

The customer has the option to choose either Fixed Sequence or Balanced Start and Hours.

**Fixed Sequence.** When Balanced Starts and Hours is disabled, the controls will operate with Fixed Sequence compressor loading. Whichever compressor that is selected to be the lead compressor will start first on a command for cooling, unless it is locked out. Compressors will be unstepped and stepped in reverse order.

**Balanced Starts and Hours.** When Balanced Starts and Hours option is enabled, the controls will start the compressor with the lowest Start Bid, defined as:

$$\text{Compressor X Start Bid} = (\# \text{ of Starts for Compressor X}) + (\text{Accumulated Running hours for Compressor X} / 10)$$

If the compressor with the lowest Start Bid is unavailable due to a circuit lockout, circuit diagnostic, or compressor diagnostic, the compressor with the next lowest Start Bid will be started.

Once compressors are running, and demand is decreased, the compressor to unstage or turn off next will be, in order of priority:

1. Any compressor running at minimum load.
2. The compressor with the greatest hours.

# Controls Interface

## CH530 Communications Overview

The Trane CH530 control system that runs the chiller consists of several elements:

- The main processor collects data, status, and diagnostic information and communicates commands to the starter module and the LLID (for Low Level Intelligent Device) bus. The main processor has an integral display (DynaView) with a built in serial port.
- Low level intelligent device (LLID) bus. The main processor communicates to each input and output device (e.g. temperature and pressure sensors, low voltage binary inputs, analog input/output) all connected to a four-wire bus, rather than the conventional control architecture of signal wires for each device.
- The communication interface to a building automation system (BAS).
- A service tool to provide all service/maintenance capabilities.

Main processor and service tool (TechView) software is downloadable from [www.trane.com](http://www.trane.com). The process is discussed later in this section under TechView Interface.

DynaView provides bus management. It has the task of restarting the link, or filling in for what it sees as “missing” devices when normal communications has been degraded. Use of TechView may be required.

The CH530 uses the IPC3 protocol based on RS485 signal technology and communicating at 19.2 Kbaud to allow 3 rounds of data per second on a 64-device network. A typical RTWD/RTUD chiller will have around 40 devices, depending upon its configuration.

Most diagnostics are handled by the DynaView. If a temperature or pressure is reported out of range by a LLID, the DynaView processes this information and calls out the diagnostic. The individual LLIDs are not responsible for any diagnostic functions.

**Note:** It is imperative that the CH530 Service Tool (TechView) be used to facilitate the replacement of any LLID or reconfigure any chiller component. TechView is discussed later in this section.

**Note:** For definition of terms, see Service Document section of Techview, or selection icon button next to setpoint title.

## Controls Interface

### DynaView

Each chiller is equipped with a DynaView interface. The DynaView has the capability to display information to the operator including the ability to adjust settings. Multiple screens are available and text is presented in multiple

languages as factory-ordered or can be easily downloaded from [www.trane.com](http://www.trane.com).

The DynaView enclosure design is weatherproof and made of durable plastic for use as a device on the outside of the unit.

The display on DynaView is a 1/4 VGA display with a resistive touch screen and an LED backlight. The display area is approximately 4 inches wide by 3 inches high (102mm x 60mm).

### Key Functions

In this touch screen application, key functions are determined completely by software and change depending upon the subject matter currently being displayed. The basic touch screen functions are outlined below.

### Radio Buttons

Radio buttons show one menu choice among two or more alternatives, all visible. (It is the AUTO button in.) The radio button model mimics the buttons used on old-fashioned radios to select stations. When one is pressed, the one that was previously pressed “pops out” and the new station is selected. In the DynaView model the possible selections are each associated with a button. The selected button is darkened, presented in reverse video to indicate it is the selected choice. The full range of possible choices as well as the current choice is always in view.

### Spin Value Buttons

Spin values are used to allow a variable setpoint to be changed, such as leaving water setpoint. The value increases or decreases by touching the increment (+) or decrement (-) arrows.

### Action Buttons

Action buttons appear temporarily and provide the user with a choice such as Enter or Cancel.

### Hot Links

Hot links are used to navigate from one view to another view.

### File Folder Tabs

File folder tabs are used to select a screen of data. Just like tabs in a file folder, these serve to title the folder/screen selected, as well as provide navigation to other screens. In DynaView, the tabs are in one row across the top of the display. The folder tabs are separated from the rest of the display by a horizontal line. Vertical lines separate the tabs from each other. The folder that is selected has no horizontal line under its tab, thereby making it look like a part of the current folder (as would an open folder in a file cabinet). The user selects a screen of information by touching the appropriate tab.

## Display Screens

### Basic Screen Format

The basic screen format appears as:

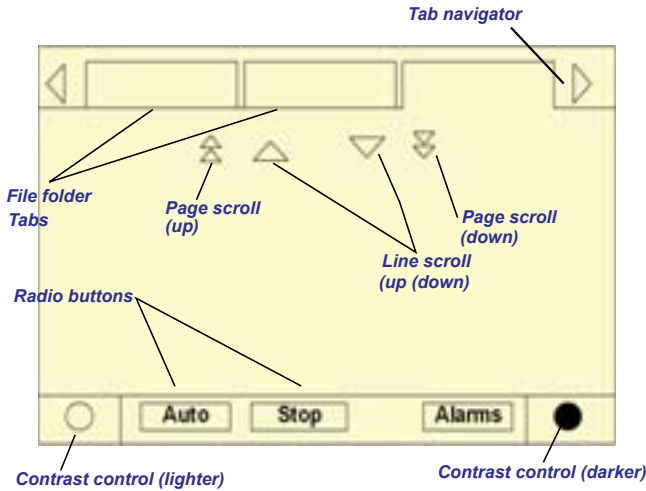

The file folder tabs across the top of the screen are used to select the various display screens.

Scroll arrows are added if more file tabs (choices) are available. When the tabs are at the left most position, the left navigator will not show and only navigation to the right will be possible. Likewise when the right most screen is selected, only left navigation will be possible.

The main body of the screen is used for description text, data, setpoints, or keys (touch sensitive areas). The Chiller Mode is displayed here.

The double up arrows cause a page-by-page scroll either up or down. The single arrow causes a line by line scroll to occur. At the end of the page, the appropriate scroll bar will disappear.

A double arrow pointing to the right indicates more information is available about the specific item on that same line. Pressing it will bring you to a subscreen that will present the information or allow changes to settings.

The bottom of the screen (Fixed Display) is present in all screens and contains the following functions. The left circular area is used to reduce the contrast/viewing angle of the display. The right circular area is used to increase the contrast/viewing angle of the display. The contrast may require re-adjustment at ambient temperatures significantly different from those present at last adjustment.

The other functions are critical to machine operation. The AUTO and STOP keys are used to enable or disable the chiller. The key selected is in black (reverse video). The chiller will stop when the STOP key is touched and after completing the Shutting Down mode.

Touching the AUTO key will enable the chiller for active cooling if no diagnostic is present. (A separate action must be taken to clear active diagnostics.)

The AUTO and STOP keys, take precedence over the Enter and Cancel keys. (While a setting is being changed, AUTO and STOP keys are recognized even if Enter or Cancel has not been pressed.)

The ALARMS button appears only when an alarm is present, and blinks (by alternating between normal and reverse video) to draw attention to a diagnostic condition. Pressing the ALARMS button takes you to the corresponding tab for additional information.

### Auto, Stop/Immediate Stop

The Auto and Stop keys will be presented as radio buttons within the persistent key display area. The selected key will be black.

The chiller will stop when the Stop key is touched, entering the Run Unload mode. An informational screen will be displayed for 5 seconds indicating that a second depression of an "Immediate Stop" key during this time period will result in an immediate stop. Pressing the "Immediate Stop" key while the immediate stop screen is displayed, will cause the unit to stop immediately, skipping normal shutdown.

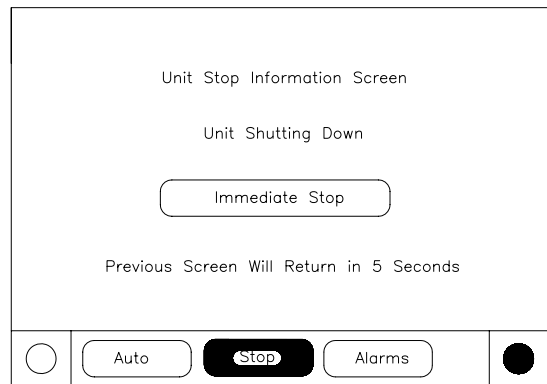

### NOTICE:

#### Equipment Damage!

**Do NOT enable/disable the chiller by removing water flow or equipment damage can occur**

Touching the Auto key will arm the chiller for active cooling if no diagnostic is present. As in UCP2, a separate action must be taken to clear active diagnostics.

The AUTO and STOP, take precedence over the ENTER and CANCEL keys. (While a setting is being changed, AUTO and STOP keys are recognized even if ENTER or CANCEL has not been pressed.)

### Diagnostic Annunciation

When an active diagnostic is present, an Alarms key will be added to the persistent display area. This key will serve two purposes. The first purpose will be to alert the

## Controls Interface

operator that a diagnostic exists. The second purpose is to provide navigation to a diagnostic display screen.

**Figure 52. Diagnostic screen**

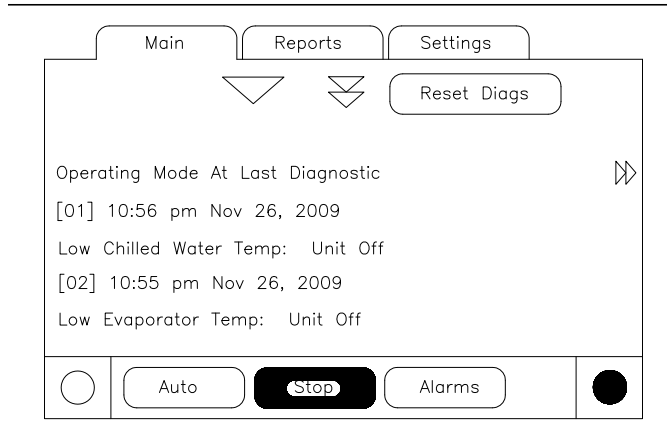

**Note:** A complete listing of diagnostics and codes is included in the Diagnostic Section.

### Manual Override Exists

An indicator to present the presence of a manual override will share space with the Alarms enunciator key. While a manual override exists, the space used for the Alarms key will be occupied by a “Manual” icon, that will display solid inverse color similar to the appearance of the Alarms enunciator. An Alarm will take precedence of the Manual, until the reset of active alarms, at which point the Manual indicator would re-appear if such an override exists.

If the Manual indicator is pressed, the Manual Control Settings screen will be displayed.

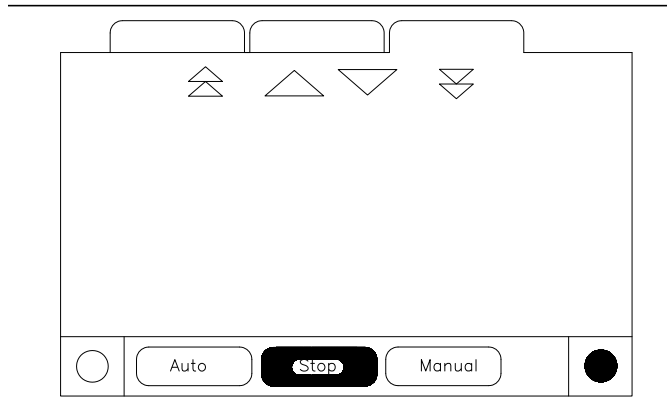

### Main Screen

The Main screen is a “dashboard” of the chiller. High level status information is presented so that a user can quickly understand the mode of operation of the chiller.

The Chiller Operating Mode will present a top level indication of the chiller mode (i.e. Auto, Running, Inhibit,

Run Inhibit, etc.). The “additional info” icon will present a subscreen that lists in further detail the subsystem modes.

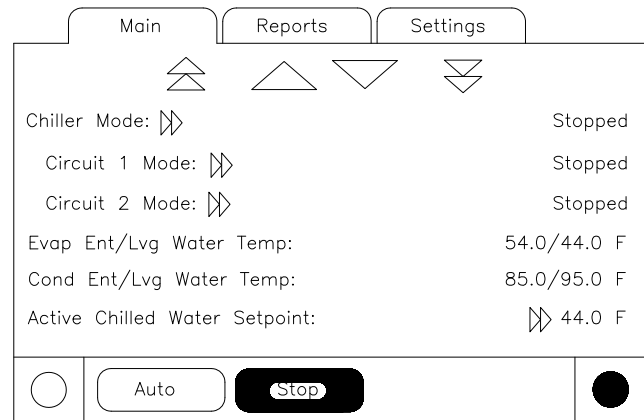

The Main screen shall be the default screen. After an idle time of 30 minutes the CH530 shall display the Main screen with the first data fields.

The remaining items (listed in the following table) will be viewed by selecting the up/down arrow icons.

**Table 106. Main screen data fields table**

Description	Units	Resolution
Chiller Mode (>> submodes)	enumeration	
Circuit 1 Mode (>> submodes)	enumeration	
Circuit 2 Mode (>> submodes)	enumeration	
Evap Ent (Lvg Water Temp)	F/C	0.1
Cond Ent (Lvg Water Temp)	F/C	0.1
Active Chilled Water Setpoint (>>source)	F/C	0.1
Active Hot Water Setpoint (>>source)	F/C	0.1
Average Line Current	%RLA	1
Active Current Limit Setpoint (>>source)	F/C	0.1
Active Ice Termination Setpoint (>>front panel setpoint)	F/C	0.1
Outdoor Air Temperature	F/C	0.1
Software Type	enumeration	RTWD/UD
Software Version		X.XX

### Chiller Operating Mode

The machine-operating mode indicates the operational status of the chiller. A subscreen with additional mode summary information will be provided by selection of an additional information icon (>>). The operating mode line will remain stationary while the remaining status items scroll with the up/down arrow keys.

## Controls Interface

**Table 107. Chiller mode**

<b>Chiller Modes</b>	<b>Description</b>
<b>Top Level Mode</b>	<b>Further information is provided by the submode</b>
<b>Sub-modes</b>	
Stopped	The chiller is not running either circuit, and cannot run without intervention.
<b>Stopped Sub-modes</b>	
Local Stop	Chiller is stopped by DynaView Stop button command- cannot be remotely overridden.
Immediate Stop	Chiller is stopped by the DynaView Immediate Stop (by pressing Stop button then Immediate Stop buttons in succession) - previous shutdown was manually commanded to shutdown immediately without a run-unload or pumpdown cycle - cannot be remotely overridden.
No Circuits Available	The entire chiller is stopped by circuit diagnostics or lockouts that may automatically clear.
Diagnostic Shutdown - Manual Reset	The chiller is stopped by a diagnostic that requires manual intervention to reset.
Cond Pmp Strt Dly (Head Pres Ctrl) min:sec	Only possible when Condenser Head Pressure Control option is enabled and the condenser pump is being manually commanded to run. This wait may be necessary due to the Head Pressure control device's stroke time.
Run Inhibit	The chiller is currently being inhibited from starting (running), but may be allowed to start if the inhibiting or diagnostic condition is cleared.
<b>Run Inhibit Sub-modes</b>	
No Circuits Available	The entire chiller is stopped by circuit diagnostics or lockouts that may automatically clear.
Ice Building Is Complete	The chiller is inhibited from running as the Ice Building process has been normally terminated on the evaporator entering temperature. The chiller will not start unless the ice building command (hardwired input or Building Automation System command) is removed or cycled.
Ice to Normal Transition	The chiller is inhibited from running for a brief period of time if it is commanded from active ice building mode into normal cooling mode via the ice building hardwired input or Tracer. This allows time for the external system load to "switchover" from an ice bank to the chilled water loop, and provides for a controlled pull down of the loop's warmer temperature. This mode is not seen if the ice making is automatically terminated on return brine temperature per the mode below.
Start is Inhibited by BAS (Building Automation System)	Chiller is stopped by Tracer or other BAS system.
Start is Inhibited by External Source	The chiller is inhibited from starting (and running) by the "external stop" hardwired input.
Diagnostic Shutdown - Auto Reset	The entire chiller is stopped by a diagnostic that may automatically clear.
Waiting for BAS Communications (to Establish Operating Status)*	The chiller is inhibited because of lack of communication with the BAS. This is only valid 15 minutes after power up.
Start is Inhibited by Low Ambient Temp	The chiller is inhibited from starting (and running) by an outdoor air ambient temperature lower than a specified temperature - per user adjustable settings and can be disabled.
Start is Inhibited by Low Condenser Temperature	The chiller is inhibited from starting due to the Low Condenser Temperature Start Inhibit function.
Start is Inhibited by Local Schedule	The chiller is inhibited from starting based on the local time of day scheduling (option).
Auto	The chiller is not currently running but can be expected to start at any moment given that the proper conditions and interlocks are satisfied.
<b>Auto Sub-modes</b>	
Waiting For Evap Water Flow	The unit will wait up to 20 minutes in this mode for water flow to be established per the flow switch hardwired input
Waiting for Need to Cool	The chiller will wait indefinitely in this mode, for a leaving water temperature higher than the Chilled Water Setpoint plus some control dead-band.
Waiting for Need to Heat	The chiller will wait indefinitely in this mode, for a leaving water temperature lower than the Hot Water Setpoint plus some control dead-band.
Power Up Delay Inhibit: min:sec	On Power Up, the chiller will wait for the Power Up Delay Timer to expire.

## Controls Interface

**Table 107. Chiller mode (continued)**

<b>Chiller Modes</b>	<b>Description</b>
<b>Top Level Mode</b>	<b>Further information is provided by the submode</b>
<b>Sub-modes</b>	
Waiting to Start	The chiller is not currently running and there is a call for cooling but the lead circuit start is delayed by certain interlocks or proofs.
<b>Waiting to Start Sub-modes</b>	
Waiting For Condenser Water Flow	The chiller will wait up to 4 minutes in this mode for condenser water flow to be established per the flow switch hardwired input.
Cond Water Pump PreRun Time min:sec	The chiller will wait up to 30 minutes (user adjustable) in this mode for to allow the condenser water loop to equalize in temperature
Cond Pmp Strt Dly (Head Pres Ctrl) min:sec	Only possible when Condenser Head Pressure Control option is enabled, this wait may be necessary due to the Head Pressure control device's stroke time.
Cprsr Strt Delay (Head Pres Ctrl) min:sec	Only possible when Condenser Head Pressure Control option is enabled, this wait may be necessary due to the Head Pressure control device's stroke time
Running	At least one circuit on the chiller is currently running.
<b>Running Sub-modes</b>	
Maximum Capacity	The chiller is operating at its maximum capacity.
Capacity Control Softloading	The control is limiting the chiller loading due to capacity based softloading setpoints.
Current Control Softloading	The chiller is running, and loading of individual compressors may be limited by a gradual filter of the chiller's softloading current limit setpoint. The starting current limit and the settling time of this filter is user adjustable as part of the current control softload feature. The mode will be displayed as long as the Current Control Softloading limit is ramping or "settling".
Running - Limit	At least one circuit on the chiller is currently running, but the operation of any of the circuits on the chiller are being actively limited by the controls chiller level limit. Other sub modes that apply to the Chiller Running top level modes may also be displayed here. Refer to the list of circuit limit modes for circuit limits that will cause display of this Chiller Level Running Limit mode.
Shutting Down	The chiller is still running but shutdown is imminent. The chiller is going through a compressor run-unload of the lag circuit/compressor.
<b>Shutting Down Sub-modes</b>	
Evaporator Water Pump Off Delay: min:sec	The Evaporator water pump is continuing to run past the shutdown of the compressors, executing the pump off delay timer.
Cond Water Pump Off Delay: min:sec	The Condenser water pump is continuing to run past the shutdown of the compressors, executing the pump off delay timer.
Misc.	These sub modes may be displayed in most of the top level chiller modes
<b>Misc. Sub-modes</b>	
Manual Evap Water Pump Override	The Evaporator water pump relay is on due to a manual command.
Diagnostic Evap Water Pump Override	The Evaporator water pump relay is on due to a diagnostic.
Diagnostic Cond Water Pump Override	The Condenser water pump relay is on due to a diagnostic.
Local Schedule Active	The local time of day scheduler (option) is operational and could automatically change modes or setpoints as scheduled. Must be enabled in Configuration menu to be functional.
Manual Condenser Water Pump Override	The condenser water pump relay is on due to a manual command.
Manual Compressor Control Signal	Chiller capacity control is being controlled by DynaView or TechView.
Hot Water Control	These modes are mutually exclusive and they indicate that the chiller is controlling to the active hot water setpoint, the active chilled water setpoint, or the active ice termination setpoint respectively.
Chilled Water Control	
Ice Building	

## Controls Interface

**Table 108. Circuit modes**

<b>Circuit Modes</b>	<b>Description</b>
<b>Top Level Mode</b>	<b>Further information is provided by the submode</b>
<b>Sub-modes</b>	
Stopped	The given circuit is not running and cannot run without intervention.
<b>Stopped Sub-modes</b>	
Diagnostic Shutdown - Manual Reset	The circuit has been shutdown on a latching diagnostic.
Front Panel Circuit Lockout	The circuit is manually locked out by the circuit lockout setting - the nonvolatile lockout setting is accessible through either the DynaView or TechView.
External Circuit Lockout	The respective circuit is locked out by the external circuit lockout binary input.
Run Inhibit	The given circuit is currently being inhibited from starting (and running), but may be allowed to start if the inhibiting or diagnostic condition is cleared.
<b>Run Inhibit Sub-modes</b>	
Diagnostic Shutdown - Auto Reset	The circuit has been shutdown on a diagnostic that may clear automatically.
Low Oil Flow Cool Down Time min:sec	See oil flow protection spec
Restart Inhibit min:sec	The compressor (and therefore, its circuit) is currently unable to start due to its restart inhibit timer. A given compressor is not allowed to start until 5 minutes (adj) has expired since its last start, once a number of "free starts" have been used up.
Auto	The given circuit is not currently running but can be expected to start at any moment given that the proper conditions and interlocks are satisfied.
<b>Auto Sub-mode</b>	
Calibrating EXV	This submode is displayed when the EXV is performing a calibration. A calibration is only performed when the chiller is not running and never more frequently than once every 24 hours
Waiting to Start	The chiller is going through the necessary steps to allow the lead circuit to start.
<b>Waiting to Start Sub-modes</b>	
Start Inhibited Waiting For Oil	The compressor (and thus its circuit) will wait up to 2 minutes in this mode for oil level to appear in the oil tank.
Waiting For EXV Preposition	The Chiller will wait for the time it takes the EXV to get to its commanded preposition prior to starting the compressor. This is typically a relatively short delay and no countdown timer is necessary (less than 15 seconds)
Running	The compressor on the given circuit is currently running.
<b>Running Sub-modes</b>	
Establishing Min Cap - Low Diff Pressure	The circuit is experiencing low system differential pressure and its compressor is being force loaded, regardless of Chilled Water Temperature Control, to develop pressure sooner.
Establishing Min Cap - High Disch Temp	The circuit is running with high discharge temperatures and its compressor is being force loaded to its step load point, without regard to the leaving water temperature control, to prevent tripping on high compressor discharge temperature.
EXV Controlling Differential Pressure	Liquid level control of the Electronic Expansion Valve has temporarily been suspended. The EXV is being modulated to control for a minimum differential pressure. This control implies low liquid levels and higher approach temperatures, but only as is necessary to provide minimum oil flow for the compressor until the condenser water loop can warm up to approximately 50F. (Future mode display - display of mode not implemented in Phase 1 or 2 although present in algorithms.)
EXV Controlling for Low Evaporator Pressure	Liquid level control of the Electronic Expansion Valve has temporarily been suspended. The EXV is being modulated to control for a minimum evaporator pressure that is based on the pressure of the Low Refrigerant Temperature Cutout. This control will tend to increase the liquid level above the setpoint or to open the valve more quickly than liquid level control can, in order to avoid an LRTC trip. It is most often invoked transiently to help open the EXV in the event of rapidly falling liquid level and rapidly declining evaporator pressures. (Future Mode display - display of mode not implemented in Phase 1 or 2 although present in algorithms.)
Running - Limited	The circuit, and compressor are currently running, but the operation of the chiller/compressor is being actively limited by the controls. * See the section below regarding criteria for annunciation of limit modes
<b>Running-Limited Sub-modes</b>	



## Controls Interface

**Table 108. Circuit modes (continued)**

Circuit Modes	Description
<b>Top Level Mode</b>	<b>Further information is provided by the submode</b>
<b>Sub-modes</b>	
Current Limit	The compressor is running and its capacity is being limited by high currents. The current limit setting is 120% RLA (to avoid overcurrent trips) or lower as set by the compressor's "share" of the active current limit (demand limit) setting for the entire chiller.*
High Condenser Pressure Limit	The circuit is experiencing condenser pressures at or near the condenser limit setting. Compressors on the circuit will be unloaded to prevent exceeding the limits.*
Low Evaporator Rfgr Temperature Limit	The circuit is experiencing saturated evaporator temperatures at or near the Low Refrigerant Temperature Cutout setting. Compressors on the circuit will be unloaded to prevent tripping. *
Hot Start Limit	This mode will occur if the leaving evaporator water temperature exceeds 75°F (for SW version 6.30 and earlier) or 90°F (for software 7.01 and later) at the point at which the step load for the respective circuit would be desired. This is often the case in a high water temperature pull-down. While in this mode, no compressor on the circuit will be allowed to load past its minimum load capacity step, but it will not inhibit other compressors from staging on. This mode is necessary to prevent nuisance trips due to Compressor Overcurrent or High Pressure Cutout. Reasonable pull-down rates can still be expected despite this limit, since the compressor's capacity even at partial load is much greater at high suction temperatures.
Shutting Down	The circuit is preparing to de-energize the compressor.
<b>Preparing Shutdown Sub-mode</b>	
Operational Pumpdown	The circuit is in the process of shutting down by performing an operational pumpdown just prior to stopping the last running compressor. The EXV is commanded closed. Pumpdown will terminate when both the liquid level and the evap pressure are low (below specific criteria) or after a specific time has expired.
Compressor Unloading: min:sec	The compressor is in its run unload time. The number of seconds remaining in run unload is shown in the submode. The run unload time must expire before the compressor will shut down.
Misc	These sub modes may be displayed in most of the top level circuit modes
<b>Misc. Sub-modes</b>	
Service Pumpdown	The circuit is currently performing a service pumpdown.
Restart Time Inhibit: min:sec	If there is accumulated Restart Inhibit Time, it must expire before a compressor is allowed to start.

### Active Chilled Water Setpoint

The active chilled water setpoint is the setpoint that is currently in use. It results from the logical hierarchy of setpoint arbitration by the main processor. It will be displayed to 0.1 degrees Fahrenheit or Celsius.

Touching the double arrow to the left of the Active Chilled Water Setpoint will take the user to the active chilled water setpoint arbitration sub-screen.

### Active Chilled Water Subscreen

The active chilled water setpoint is that setpoint to which the unit is currently controlling. It is the result of arbitration between the front panel, BAS, schedule, external, and auxiliary setpoints (schedule and auxiliary not shown in the following diagram), which in turn may be subjected to a form of chilled water reset.

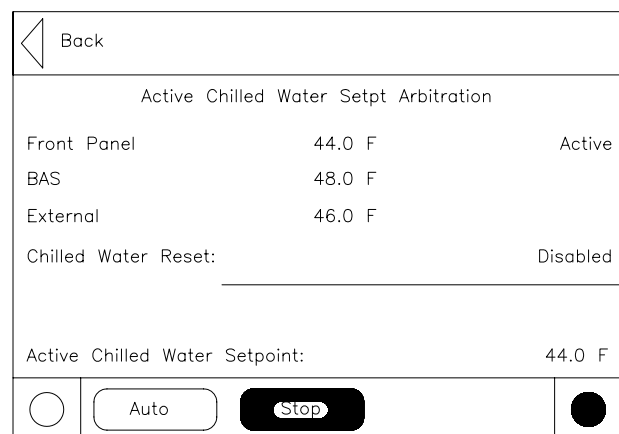

The chilled water reset status area in the right most column will display one of the following messages

- Return

## Controls Interface

- Constant Return
- Outdoor
- Disabled

The left column text “Front Panel”, “BAS” or “Schedule”, “External”, “Auxiliary”, “Chilled Water Reset”, and “Active Chilled Water Setpoint” will always be present regardless of installation or enabling those optional items. In the second column “-----” will be shown if that option is Not Installed, otherwise the current setpoint from that source will be shown.

Setpoints that are adjustable from the DynaView (Front Panel Chilled Water Setpoint, Auxiliary Chilled Water Setpoint) will provide navigation to their respective setpoint change screen via a double-arrow to the right of the setpoint source text. The setpoint change screen will look identical to the one provided in the Chiller Setpoints screen. The “Back” button on the setpoint change screen provides navigation back to the setpoint arbitration screen.

The “Back” button on the setpoint arbitration screen provides navigation back to the chiller screen.

### Other Active Setpoints

The Active Current Limit Setpoint will behave the same was as the Active Chilled Water Setpoint, except that its units are in percent and there is an Ice Building source in place of the Auxiliary source. Front Panel Current Limit Setpoint will provide navigation to its setpoint change screen.

### Settings Screen

The Settings screen provides a user the ability to adjust settings necessary to support daily tasks. The layout provides a list of sub-menus, organized by typical subsystem. This organization allows each subscreen to be shorter in length which should improve the user's navigation.

A sample Settings screen is a list of the subsystems as shown below.

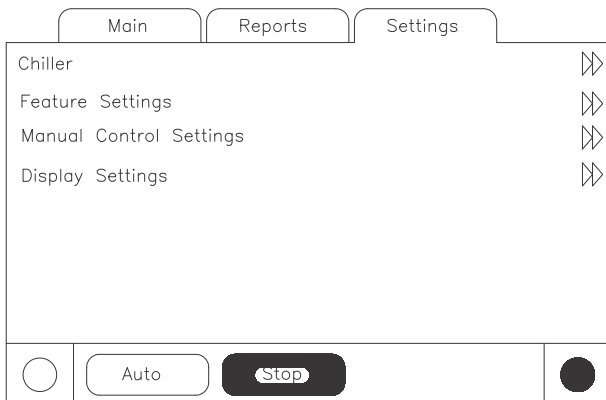

### Settings Sub-Screens - Table of Text, Data, Ranges, etc.

Below is the table of text, resolution, field size, enumerated selections, and data for Settings subscreens.

**Table 109. Chiller**

Description	Resolution or (Enumerations), Default	Units
Front Panel Cool/Heat Command	(Cool, Heat), Cool	Enum
Front Panel Chilled Water Setpt:	+ or - XXX.X	Temperature
Front Panel Hot Water Setpt	+ or - XXX.X	Temperature
Front Panel Current Limit Setpt:	XXX	%RLA
Front Panel Ice Build Cmd	On/Auto	Enum
Front Panel Ice Termination Setpoint	XXX.X	Temperature
Setpoint Source:	(BAS/Ext/FP, Ext/Front Panel, Front Panel), BAS/Ext/FP	Enum
Differential to Start	XX.X	Delta Temperature
Differential to Stop	XX.X	Delta Temperature
Leaving Water Temp Cutout	XX.X	Temperature
Low Refrigerant Temp Cutout	XX.X	Temperature
Staging Sequence	(Bal Starts/Hrs, Fixed), Bal Starts/Hrs	Enum
Condenser Pump Prestart Time	XX, 0	Minutes

**Table 110. Feature settings**

Description	Resolution or (Enumerations), Default	Units
Cooling Low Ambient Lockout	(Enable, Disable), Enable	Enum
<i>Cooling Low Ambient Lockout Subscreen (see below)</i>		
Cooling Low Ambient Lockout	(Enable, Disable), Enable	Enum
Cooling Low Amb Lockout Setpt	XXX.X	Temp
Ice Building:	(Enable, Disable), Disable	Enum
Ext Chilled/Hot Water Setpt	(Enable, Disable), Disable	Enum
Ext Current Limit Setpoint	(Enable, Disable), Disable	Enum
Chilled Water Reset	(Const Return, Outdoor, Return, Disable), Disable	Enum
<i>Chilled Water Reset Subscreens (see below)</i>		

## Controls Interface

**Table 110. Feature settings (continued)**

Description	Resolution or (Enumerations), Default	Units
Chilled Water Reset	(Const Return, Outdoor, Return, Disable), Disable	Enum
Return Reset Ratio	XXX	%
Return Start Ratio	XXX.X	Temp
Return Maximum Reset	XXX.X	Temp
Outdoor Reset Ratio	XXX	%
Outdoor Start Reset	XXX.X	Temp
Outdoor Maximum Reset	XXX.X	Temp
LCI-C Diag Language	(English, Selection 2, Selection 3) English (0)	Enum
LCI-C Diag Encoding	(Text, Code) Text	Enum

**Table 111. System manual control settings**

Description	Resolution or (Enumerations), Default	Units	Monitor Value
Evap Water Pump	(Auto, On), Auto	Enum	1) Water Flow status 2) Override Time Remaining
Cond Water Pump	(Auto, On), Auto	Enum	1) Water Flow status 2) Override Time Remaining
Head Pressure Control	(Auto, On), Auto	Enum	1) Override status - Auto/Manual
Staging (Stepping Control)	(Auto, Manual) Auto	Enum	1) Override status - Auto/Manual
Capacity Modulation Control	(Auto, Manual) Auto	Enum	1) Override status - Auto/Manual
Clear Energy Consumption	1) Resettable Energy consumption totalization (kWh)	Enum	1) Resettable Energy consumption totalization (kWh)

**Table 112. Circuit manual control settings**

Description	Resolution or (Enumerations), Default	Units	Monitor Value
Compressor Pumpdown	(Continue, Not Available)	Enum	1) Override status: Not Available/Continue/Starting/Pumpdown 2) Suction Pressure
Front Panel Ckt Lockout	(Not Locked Out, Locked Out), Not Locked Out	Enum	
Expansion Valve Control	(Auto, Manual)	Enum	

### Local Time of Day Schedule Screen

To access the optional Local Time of Day Schedule Screen it must be configured in TechView. This option will then be shown under the Feature Settings screen.

This screen shows the overall feature enable/disable setting, plus a listing of all 10 events, including their event time and active days of the week.



### Local Settings Event Screen

This screen displays the details for a particular event, including the active days, event time, and the Local Schedule arbitrated setpoints. Selecting a given item will allow the user to modify it.

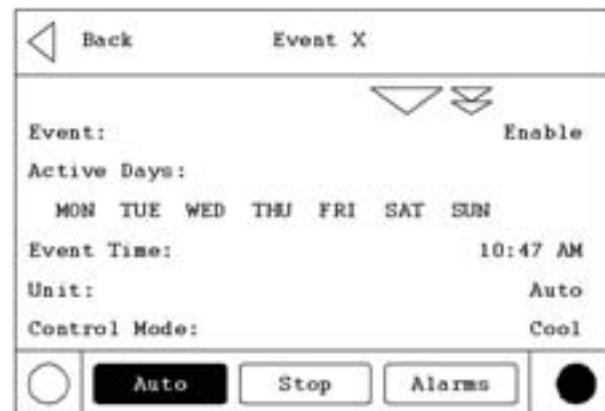



**Event Time Screen**



**Event Enable/Disable Screen**

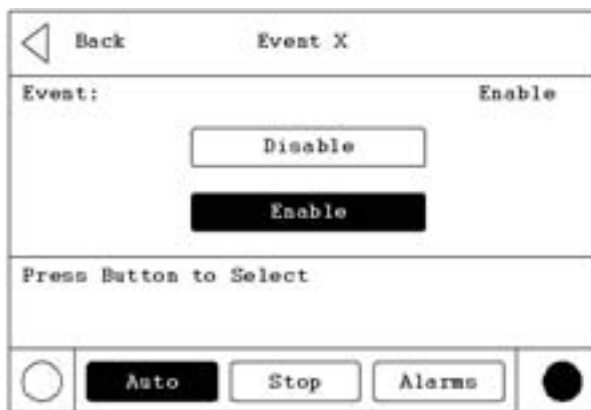

**Event Active Days Screen**

This screen is unusual because it does not use radio buttons, which only allow one active selection at a time. These buttons are more like "selection buttons" or check boxes. The user can select any combination of days, or none at all.

**Event Arbitrated Settings Screens**

For analog setpoints, the screen is slightly different than the standard screen, because there are two additional buttons - "Enable" and "Disable". Selecting "Used" will make the setting valid and allow the user to change the value. Selecting "Not Used" will make the setting invalid, and will not allow the user to change the value.

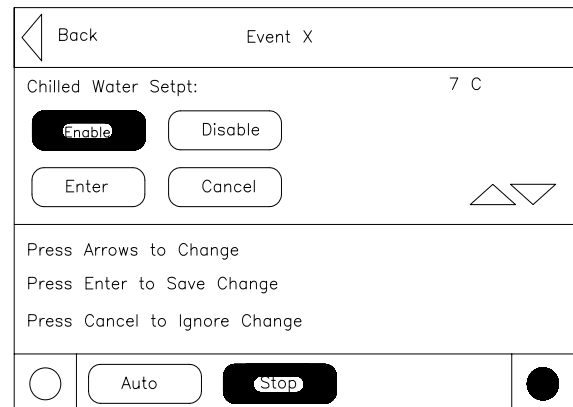

## Controls Interface

### Display Settings Screen

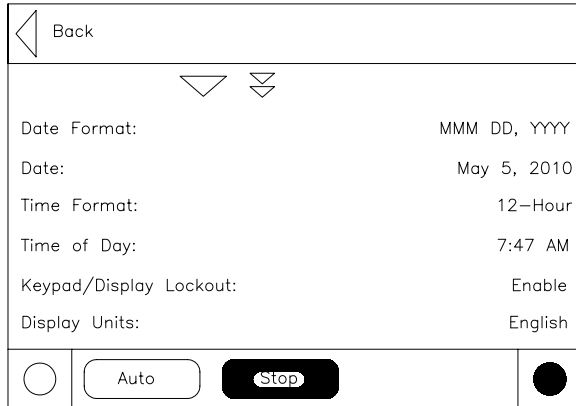

**Table 113. Display settings**

Description	Resolution or (Enumerations), Default	Units
Date Format	("mmm dd, yyyy", "dd-mmm-yyyy"), "mmm dd, yyyy"	Enum
Date <sup>3</sup>		
Time Format	(12-hour, 24-hour), 12-hour	Enum
Time of Day <sup>3</sup>		
Keypad (Display Lockout) <sup>2</sup>	(Enable, Disable), Disable	Enum
Display Units	(SI, English), SI	Enum
Pressure Units	(Absolute, Gauge), Gauge	Enum
Language <sup>4</sup>	(English, Selection 2, Selection 3), English <sup>1</sup>	Enum

**Notes:**

1. Language choices are dependent on what the Service Tool has setup in the Main Processor. Get Radio Button names from Main Processor setups. Language selections will include English and qty 2 alternate as loaded by TechView.
2. Enables a DynaView Lockout screen. All other screens timeout in 30 minutes to this screen. The DynaView Lockout Screen will have 0-9 keypad to permit the user to re-enter the other DynaView screens with a fixed password (159).
3. The Date and Time setup screen formats deviate slightly from the standard screens defined above. See the alternate screen layouts below.
4. Language shall always be the last setting listed on the Control Settings menu (which will also always be the last item listed on the Settings menu list). This will allow a user to easily find language selection if looking at an unrecognizable language.

Upon selecting a Settings list all setpoints available to change along with their current value will appear. The operator selects a setpoint to change by touching either the verbal description or setpoint value. Doing this causes the screen to switch to either the Analog Settings Subscreen or the Enumerated Settings Subscreen.

### Analog Setting Subscreens

Analog Settings Subscreen displays the current value of the chosen setpoint in the upper 1/2 of the display. It is

displayed in a changeable format consistent with its type. Binary setpoints are considered to be simple two state enumerations and will use radio buttons. Analog setpoints are displayed as spin buttons. The lower half of the screen is reserved for help screens.

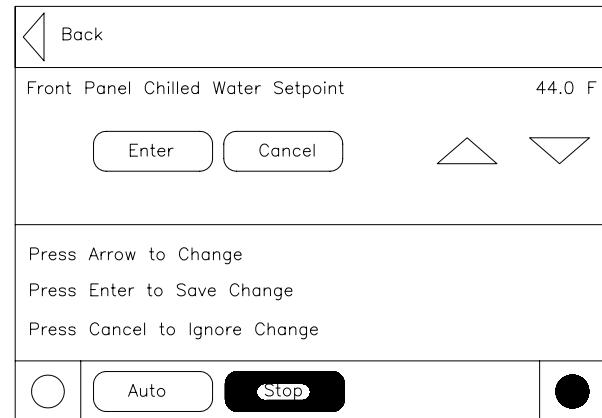

All setpoint subscreens will execute the equivalent of a Cancel key if any display activities cause the subscreen to be left before a new setpoint is entered. E.g. if the Alarms key is pressed before a new setpoint is entered, the new setpoint will be cancelled. The same applies to any time-outs.

Pressing the Auto or Stop keys will not cause a cancel since the setpoint subscreen is not left on this action.

### Enumerated Settings Subscreen

The enumerated setpoint subscreen has no cancel or enter key. Once a radio key is depressed the item is immediately set to the new enumeration value.

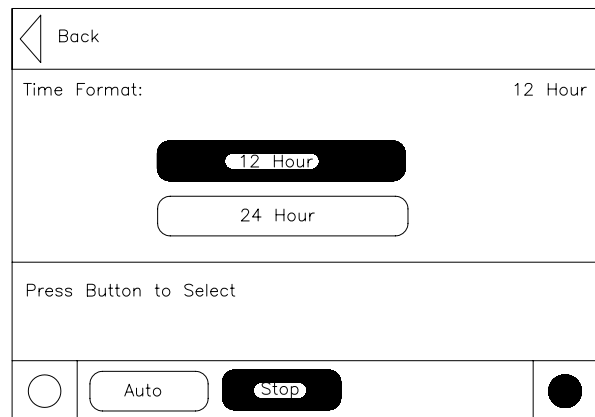

### Mode Override Subscreens

The Mode Override subscreen has no cancel or enter key. Once a radio key is depressed that new value is immediately assumed.

## Controls Interface

---

Mode Override for Enumerated Settings is shown below:

◀ Back	
Evap Water Pump:	Auto
<input checked="" type="radio"/> Auto	<input type="radio"/> On
Manual Override Time Remaining:	60:00
Evap Water Flow Switch Status:	No Flow
Press Button to Select	
<input type="radio"/>	<input type="radio"/> Auto <input checked="" type="radio"/> Stop <input type="radio"/>

### Date/Time Subscreen

The setpoint screen for setting up the CH530 date is shown below: The user must select Day, Month, or Year and then use the up/down arrows to adjust.

◀ Back	
Date:	Sep 28, 2001
<input checked="" type="radio"/> Day	<input type="radio"/> Month <input type="radio"/> Year
<input type="radio"/> Enter	<input type="radio"/> Cancel
▲ ▼	
Press Arrow to Change	
Press Enter to Save Change	
Press Cancel to Ignore Change	
<input type="radio"/>	<input type="radio"/> Auto <input checked="" type="radio"/> Stop <input type="radio"/>

The setpoint screen for setting up the CH530 time with a 12 hour format is shown below: The user must select Hour or Minute and then use the up/down arrows to adjust. Adjusting hours will also adjust am/pm.

◀ Back	
Time of Day:	11:33 AM
<input checked="" type="radio"/> Hour	<input type="radio"/> Minute
<input type="radio"/> Enter	<input type="radio"/> Cancel
▲ ▼	
Press Arrow to Change	
Press Enter to Save Change	
Press Cancel to Ignore Change	
<input type="radio"/>	<input type="radio"/> Auto <input checked="" type="radio"/> Stop <input type="radio"/>

## Controls Interface

### Lockout Screen

The DynaView Display and Touch Screen Lock screen is shown. This screen is used if the Display and Touch Screen Lock feature is Enabled. Thirty minutes after the last key stroke this screen will be displayed and the Display and Touch Screen will be locked out until "159 Enter" is entered.

Until the proper password is entered there will be no access to the DynaView screens including all reports, all setpoints, and Auto/Stop/Alarms/Interlocks. The password "159" is not programmable from either DynaView or TechView.

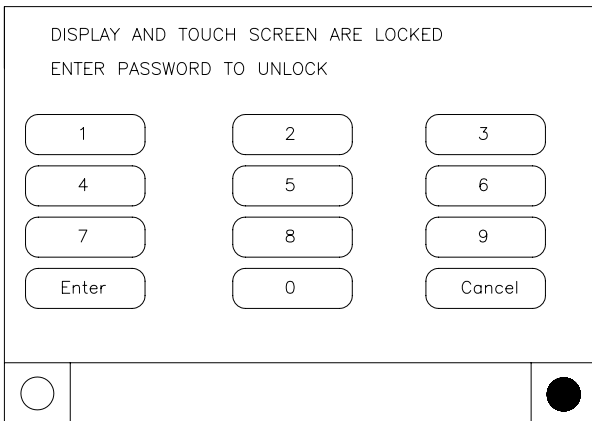

If the Display and Touch Screen Lock feature is Disabled, a similar screen including "Enter 159 to Unlock" will show if the MP temperature is approximately less than 32°F (0°C) and it has been 30 minutes after the last key stroke.

### Reports

The Reports tab will allow a user to select from a list of possible reports headings (i.e. Custom, ASHRAE Chiller Log, Refrigerant, etc.) Each report will generate a list of status items as defined in the tables that follow:

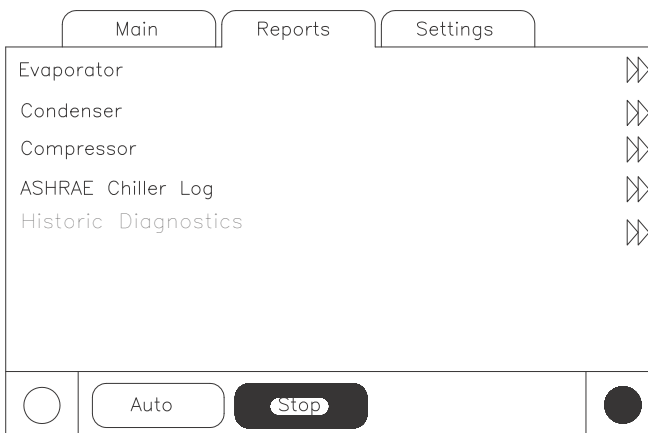

**Table 114. Report name: system evaporator**

Description	Resolution	Units
Evap Entering Water Temp:	+ or - XXX.X	Temperature
Evap Leaving Water Temp:	+ or - XXX.X	Temperature
Evap Water Flow Switch Status:	Flow, No Flow	Enumeration

**Figure 53. Report name: circuit evaporator**

Description	Resolution	Units
Evap Entering Water Temperature	+/- XXX.X	Temperature
Evap Leaving Water Temperature	+/- XXX.X	Temperature
Evap Sat Rfght Temp	+/- XXX.X	Temperature
Suction Pressure	XXX.X	Pressure
Evap Approach Temp:	+/- XXX.X	Temperature
Evap Water Flow Switch Status (Flow, No Flow)		Enum
Expansion Valve Position	XXX.X	%
Expansion Valve Position Steps	XXXX	Steps
Evaporator Liquid Level	XX.X	Height

**Table 115. Report name: system condenser**

Description	Resolution	Units
Cond Entering Water Temp	+/- XXX.X	Temperature
Cond Leaving Water Temp	+/- XXX.X	Temperature
Cond Water Flow Switch Status (Flow, No Flow)		Enum
Outdoor Air Temperature	+/- XXX.X	Temperature
Cond Head Pressure Ctrol	XXX	%

**Table 116. Report name: circuit condenser**

Description	Resolution	Units
Cond Entering Water Temp	+/- XXX.X	Temperature
Cond Leaving Water Temp	+/- XXX.X	Temperature
Condenser Air Flow	XXX	%
Cond Inverter Speed	XXX	%
Outdoor Air Temperature	+/- XXX.X	Temperature
Cond Water Flow Switch Status (Flow, No Flow)		Enum
Cond Sat Rfght Temp	+/- XXX.X	Temperature
Cond Rfght Pressure	XXX.X	Pressure
Differential Pressure	XXX.X	Pressure
Cond Approach Temp	+/- XXX.X	Temperature

**Table 117. Report name: system compressor**

Description	Resolution	Units
Average Line Current	XXX	%RLA
Unit Volts	XXX	Volts
Unit Running Time	XXXX:XX	hr:min
Power Demand		kW
Power Demand Time Period		min

**Table 117. Report name: system compressor (continued)**

Description	Resolution	Units
Energy Consump - Resettable		kWh
Time of Last Reset		time-date
Energy Consump - NonReset		kWh

**Table 118. Report name: circuit compressor**

Description	Resolution	Units
Oil Pressure	XXX.X	Pressure
Compressor Rfgt Dschg Temp	+/- XXX.X	Temperature
Cond Sat Rfgt Temp	+/- XXX.X	Temperature
Average Line Current	XXX	%RLA
%RLA L1 L2 L3	XXX.X	%RLA
Amps L1 L2 L3	XXX.X	Amps
Phase Voltages	XXX	Vac
Power Consumption	XXX	kW
Load Power Factor	X.XXX	
Compressor Starts	XXXX	Integer
Compressor Running Time	XXXX:XX	hr:min

**Table 119. Report name: system ASHRAE chiller log**

Description	Resolution	Units
Current Time/Date:	XX:XX mmm dd, yyyy	Date/Time
Chiller Mode:		Enum
Active Chilled Water Setpoint:	XXX.X	Temperature
Active Hot Water Setpoint:	XXX.X	Temperature
Evap Entering Water Temp:	XXX.X	Temperature
Evap Leaving Water Temp:	XXX.X	Temperature
Evap Water Flow Switch Status:		Enum
Outdoor Air Temperature:	XXX.X	Temperature

**Table 120. Report name: circuit ASHRAE chiller log**

Description	Resolution	Units
Circuit Mode:		Enum
Evap Sat Rfgt Temp	XXX.X	Temperature
Suction Pressure	XXX.X	Pressure
Evap Approach Temp	XXX.X	Temperature
Cond Sat Rfgt Temp:	XXX.X	Temperature
Cond Rfgt Pressure	XXX.X	Pressure
Cond Approach Temp	XXX.X	Temperature
Compressor Starts	XXXX	Integer
Compressor Running Time	XX:XX	Hours:Minutes

## Power Up and Self Tests

### Power-Up DynaView

On Power-Up DynaView will progress through three screens:

First Screen, Application Status, Boot Software P/N, Self Test and Application Time Stamp.

This screen will display for 3-10 seconds. This screen will give the status of the Application software, the Boot Software P/N, display SelfTest results and display the Application Part Number. The contrast will also be adjustable from this screen. The message "Selftest Passed" may be replaced with "Err2: RAM Error" or "Err3: CRC Failure"

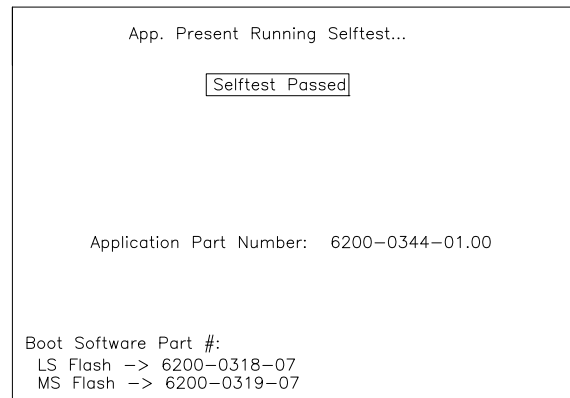

### Display Formats

Temperature settings can be expressed in F or C, depending on Display Units settings.

Pressure settings can be expressed in psia, psig, kPaa (kPa absolute), or kPag (kPa gauge) depending on Display Units settings.

Dashes ("----") appearing in a temperature or pressure report, indicates that the value is invalid or not applicable.

### Languages

The languages for DynaView will reside in the main processor. The main processor will hold three languages, English, and two alternate languages. The service tool (TechView) will load the main processor with user selected languages from a list of available translations.



## Controls Interface

### TechView



TechView is the PC (laptop) based tool used for servicing Tracer CH530. Technicians that make any chiller control modification or service any diagnostic with Tracer CH530 must use a laptop running the software application "TechView." TechView is a Trane application developed to minimize chiller downtime and aid the technicians understanding of chiller operation and service requirements.

**Important:** Performing any Tracer CH530 service functions should be done only by a properly trained service technician. Please contact your local Trane service agency for assistance with any service requirements.

TechView software is available via Trane.com.

<http://www.trane.com/COMMERCIAL/DesignAnalysis/TechView.aspx?i=1435>

This download site provides a user the TechView installation software and CH530 main processor software that must be loaded onto your PC in order to service a CH530 main processor. The TechView service tool is used to load software into the Tracer CH530 main processor.

#### TechView Software Download, Installation

This information can also be found at <http://www.trane.com/COMMERCIAL/DesignAnalysis/TechView.aspx?i=1435>.

1. Create a folder called "CH530" on your (C:\CH530) on your hard drive. This \CH530 folder is the standard recommended location for the installation file. Storing the installation file in this location helps you remember where it is stored and makes it easier for technical support personnel to assist you.
2. Click the link for the latest version on the TechView Software Download page. Enter your name, e-mail address and other required information. Click Submit.

3. A download link will be sent to the e-mail address provided. Before you click the link please note:

- Sent link may only be used one time.
- Internet options must be set correctly to allow download. To verify correct setting:
  - Open Internet Explorer Browser
  - Click Tools
  - Select Internet Options
  - Select Security tab
  - Click on Internet zone
  - Click Custom Level button
  - Scroll to Downloads section
  - Verify/Enable "Automatic prompting for file downloads"
  - Click OK
  - Click YES on warning window
  - Click Apply, then OK

**Note:** If this setting is incorrect, you may or may not receive an error message during download attempt.

4. Click the download link in the e-mail message.
  - If the download window does not open immediately, please look for a yellow highlighted message bar/line near the top of your browser. It may contain a message such as "To help protect your security, Internet Explorer blocked this site from downloading files to your computer. Click here for options.." Click on message line to see options.
  - When dialog box appears, click Save and navigate to the CH530 folder created in [Step 1](#). Click OK.
  - If you do not complete the download successfully, you will have to request another download link ([Step 2](#)).
5. Navigate to the CH530 folder created in [Step 1](#). Double-click the installation (.exe) file. The License Agreement dialog box appears.
6. Click I Agree after reviewing License Agreement. The Choose Components dialog box appears. All components are selected by default. (These are the actual MP versions for all units.) Deselect any components you do not want.

**Note:** Deselecting components reduces the size of the installed application.

7. Click Install. A progress meter dialog box appears. An information file appears when installation is complete.

**Note:** Techview requires a current version of JAVA. If you do not have the current release, TechView installation will be interrupted, and you will be provided with information for required JAVA software download. Once you have completed the JAVA installation, return to [Step 5](#) to restart installation.

**Minimum PC requirements to install and operate TechView**

- Microsoft Windows XP Professional or Windows Vista Business operating system
- Internet Explorer 6.0 and higher
- USB 2.0 or higher
- Pentium II, III, or higher processor
- 128MB RAM minimum
- 1024 x 768 resolution
- CD-ROM (optional for copying TechView install to CD)
- 56K modem (optional for internet connection)
- 9-pin RS-232 serial connection (optional for connection to DynaView)

Note: TechView was designed and validated for this specific laptop configuration. Any variation from this configuration may have different results. Therefore, support for TechView is limited to only those laptops configured as described above. Trane will not support TechView on laptops configured differently. There is no support for laptops running Intel Celeron, AMD, Cyrix or processors other than Pentium.

**Optional Software**

- Microsoft Office with Access

TechView is also used to perform any CH530 service or maintenance function. Servicing a CH530 main processor includes:

- Updating main processor software
- Monitoring chiller operation
- Viewing and resetting chiller diagnostics
- Low Level Intelligent Device (LLID) replacement and binding
- Main processor replacement and configuration modifications
- Setpoint modifications
- Service overrides

**Unit View**

Unit view is a summary for the system organized by chiller subsystem. This provides an overall view of chiller operating parameters and gives you an "at-a-glance" assessment of chiller operation.

The Status tab displays important operating information for the unit and allows you to change several key operating parameters. The panel is divided into four or more sub-panels (depending on the number of circuits in the unit).

The Chiller Operating Mode tab displays the unit, circuit and compressor top level operating modes. Upon successful Local Connect, Tech View will display UNIT VIEW. RTWD and RTUD Unit Views are shown below.

**Figure 54. Unit View (RTWD)**

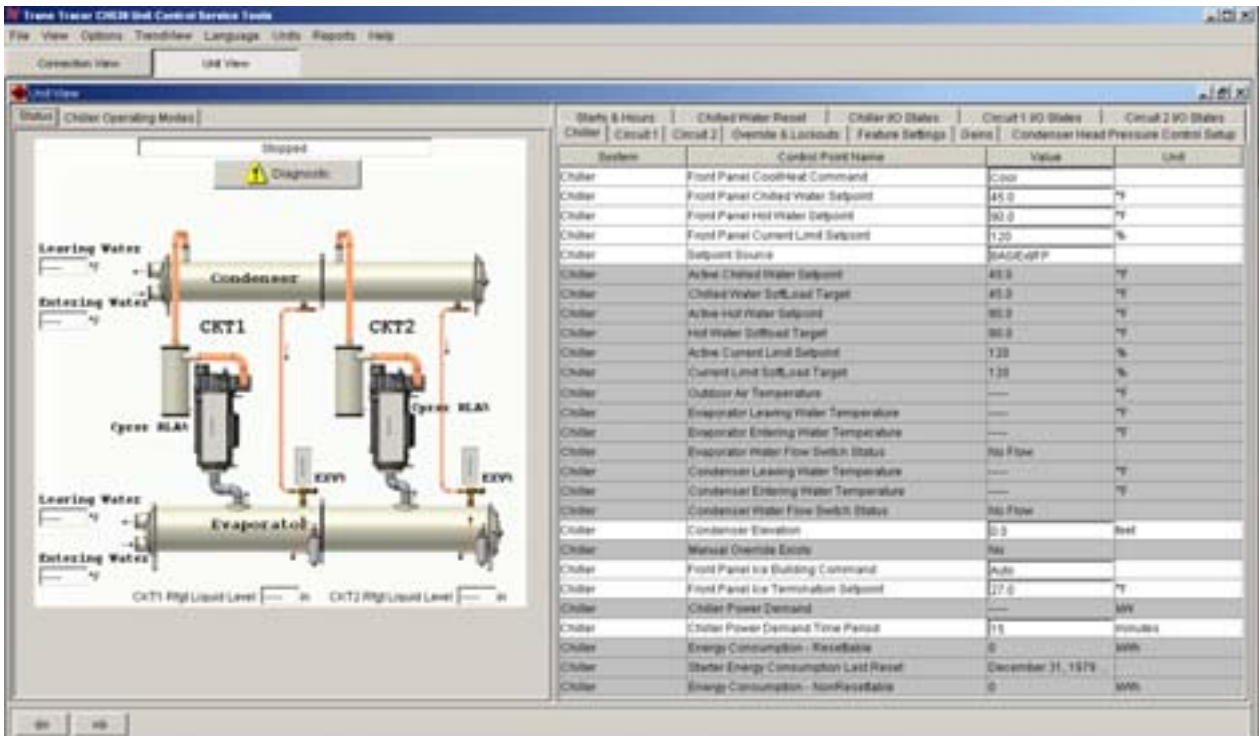

## Controls Interface

Figure 55. Unit view (RTUD)

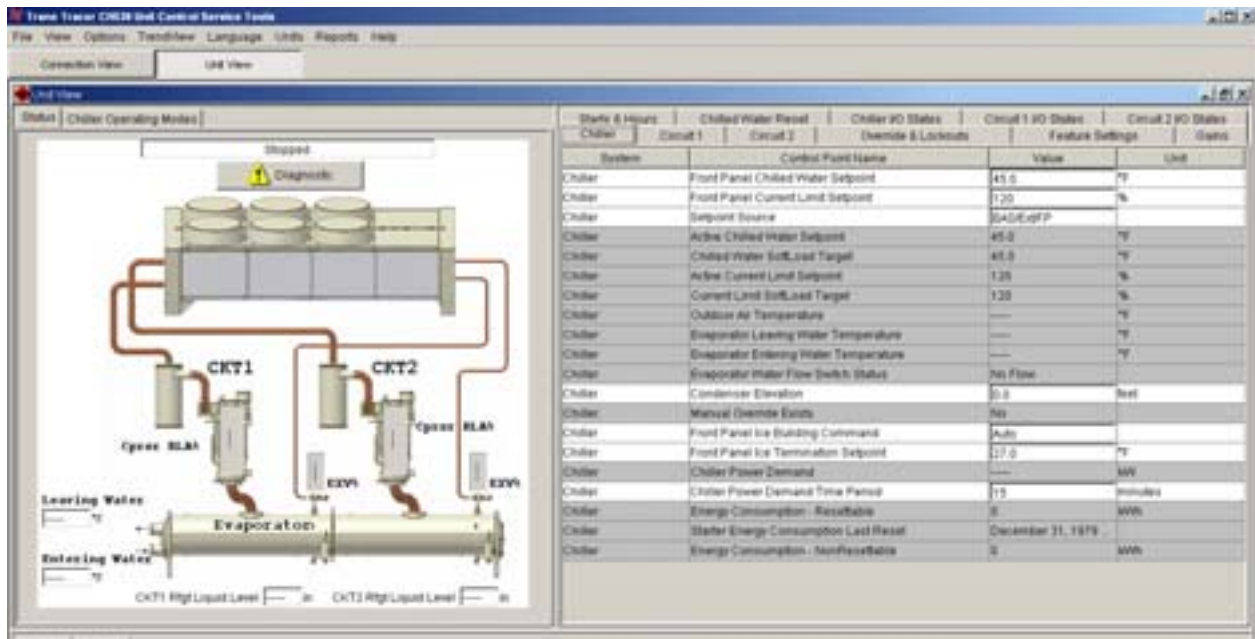

The Unit View displays the system, control point name, value and unit of measure. It reflects active setpoints and allows you to make changes.

UnitView also displays, in real time, all non-setpoint data organized by tabs. As data changes on the chiller, it is automatically updated in the Unit View.

### Circuit/Compressor Lockout)

In order to lockout a circuit the user must go to the Unit View/Circuit 1 (or Circuit 2) Tab and then select the Front Panel Lockout for Circuit 1 and/or Circuit 2. The user can select Not Locked Out or Locked Out.

### Condenser Elevation Configuration - RTUD Installations

Condenser elevation setting is a required input during startup of RTUD units. Go to the Unit View/Chiller Tab, select Condenser Elevation setting and enter condenser elevation in appropriate units. Reference [Figure , p. 148](#). The shipped default of this setting is 0 and it represents the distance of the bottom of the condenser, relative to the top of the evaporator. Use a positive value for the condenser above the evaporator and a negative value for the condenser below the evaporator. An estimate to within +/- 3 feet is required.

Figure 56. Unit view - RTUD condenser elevation

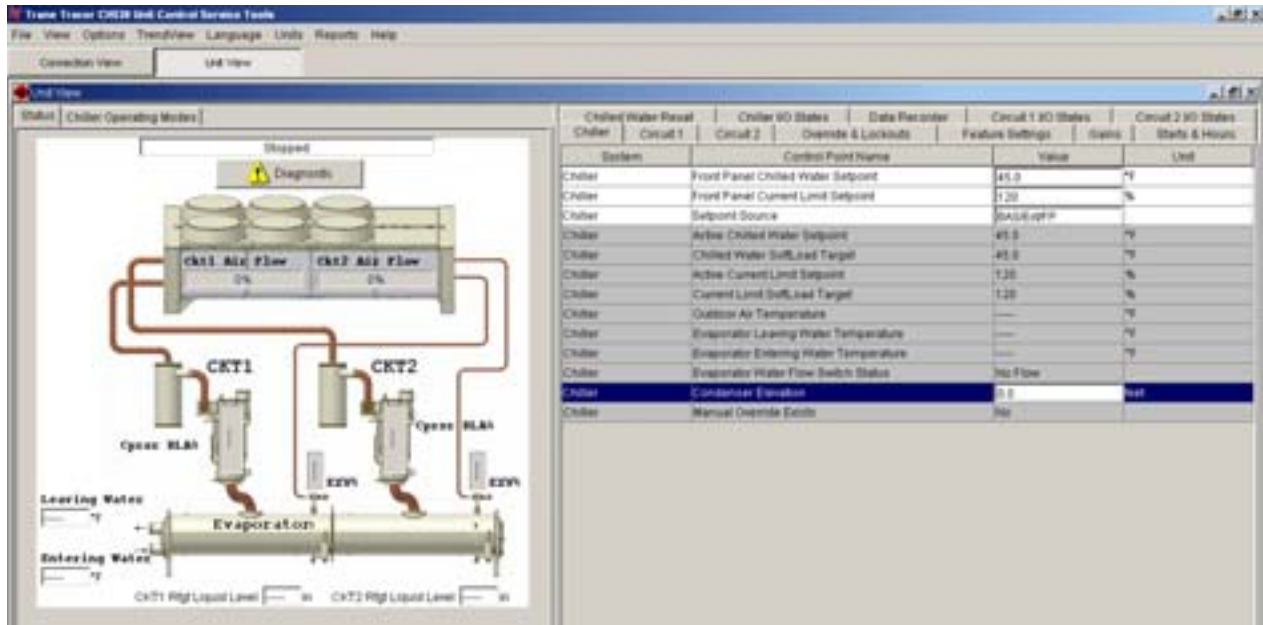

Table 121. Unit view tabs - detail

Tab	System	Control Point Name	Status	Unit	Min	Max	Default
<b>Chiller</b>							
	Chiller	Front Panel Cool/heat Command	Setting				
	Chiller	Front Panel Chilled Water Setpoint	Setpoint	deg F (C)	10 (-12.22)	65 (18.33)	45 (7.22)
	Chiller	Front Panel Hot Water Setpoint	Setpoint	deg F (C)	80 (26.66)	140 (60)	90 (32.22)
	Chiller	Front Panel Current Limit Setpoint	Setpoint	%RLA	60	120	120
	Chiller	Setpoint Source	Setting				
	Chiller	Active Chilled Water Setpoint	Status	°F (°C)			
	Chiller	Chilled Water Softload Target	Status	°F (°C)			
	Chiller	Active Hot Water Setpoint	Status	°F (°C)			
	Chiller	Hot Water Softload Target	Status	°F (°C)			
	Chiller	Active Current Limit Setpoint	Status	% RLA			
	Chiller	Current Limit SoftLoad Target	Status	% RLA			
	Chiller	Outdoor Air Temperature	Status	°F (°C)			
	Chiller	Evaporator Leaving Water Temperature	Status	°F (°C)			
	Chiller	Evaporator Entering Water Temperature	Status	°F (°C)			
	Chiller	Evaporator Water Flow Switch Status	Status				
	Chiller	Condenser Leaving Water Temperature	Status	°F (°C)			
	Chiller	Condenser Entering Water Temperature	Status	°F (°C)			
	Chiller	Condenser Water Flow Switch Status	Status				
	Chiller	Condenser Elevation	Setting	ft	-26.25	98.43	0
	Chiller	Manual Override Exists	Status				
	Chiller	Front Panel Ice Building Command	Setting				
	Chiller	Front Panel Ice Termination Setpoint	Setting	°F (°C)	20	32	27
	Chiller	Chiller Power Demand	Status				

## Controls Interface

**Table 121. Unit view tabs - detail (continued)**

Tab	System	Control Point Name	Status	Unit	Min	Max	Default
	Chiller	Chiller Power Demand Time Period	Setting	min	1	60	15
	Chiller	Energy Consumption - Resettable	Status				
	Chiller	Starter Energy Consumption Last Reset	Status				
	Chiller	Energy Consumption - NonResettable	Status				
<b>Circuit 1</b>							
	Circuit 1	Front Panel Circuit Lockout	Setting				Not locked out
	Circuit 1	External Circuit Lockout Status	Status				Not locked out
	Circuit 1	Evaporator Refrigerant Pressure	Status	psi gauge			
	Circuit 1	Evaporator Saturated Refrigerant Temperature	Status	°F (°C)			
	Circuit 1	Evaporator Approach Temperature	Status	°F (°C)			
	Circuit 1	Evaporator Refrigerant Liquid Level	Status	in (mm)			
	Circuit 1	Evaporator Refrigerant Liquid Level Error	Status	in (mm)			
	Circuit 1	EXV Percent Open	Status	%			
	Circuit 1	EXV Position Steps	Status	steps			
	Circuit 1	Differential Refrigerant Pressure	Status	psid			
	Circuit 1	Condenser Refrigerant Pressure	Status	psi gauge			
	Circuit 1	Condenser Saturated Refrigerant Temperature	Status	°F (°C)			
	Circuit 1	Compressor Refrigerant Discharge Temperature	Status	°F (°C)			
	Circuit 1	Condenser Approach Temperature	Status	°F (°C)			
	Circuit 1	Compressor Refrigerant Discharge Superheat	Status	°F (°C)			
	Circuit 1	Compressor 1A Oil Pressure	Status	psi gauge			
	Circuit 1	Compressor 1A Average Line Current	Status	% RLA			
	Circuit 1	Compressor 1A Line 1 Current	Status	% RLA			
	Circuit 1	Compressor 1A Line 2 Current	Status	% RLA			
	Circuit 1	Compressor 1A Line 3 Current	Status	% RLA			
	Circuit 1	Starter 1A Voltage Vab	Status	volts			
	Circuit 1	Starter 1A Voltage Vbc	Status	volts			
	Circuit 1	Starter 1A Voltage Vca	Status	volts			
	Circuit 1	Compressor 1A Power Consumption	Status	kW			
	Circuit 1	Compressor 1A Power Factor	Status				
	Circuit 1	Modulation Unload Steady Command	Status				
	Circuit 1	Condenser Air Flow	Status	% of fan deck			
	Circuit 1	Condenser Inverter Speed	Status	% of inverter full speed			
	Circuit 1	Average Condenser Approach Temperature	Status	Diff Temp °F (°C)			
	Circuit 1	Re-initialize Average Condenser Approach Temperature	Setting				
	Circuit 1	Compressor 1A Average Oil Pressure Drop	Status	% of System DP			
	Circuit 1	Re-initialize Compressor 1A Average Oil Pressure Drop	Setting				
	Circuit 1	Compressor 1A Oil Filter Life Remaining	Status	%			
	Circuit 1	Re-initialize Compressor 1A Oil Filter Life Remaining	Setting				
	Circuit 1	Time Remaining Until Oil Analysis Recommended	Status	Hrs			
	Circuit 1	Re-initialize Oil Time Remaining	Setting				
<b>Circuit 2</b>							
	Circuit 2	Front Panel Circuit Lockout	Setting				
	Circuit 2	External Circuit Lockout Status	Status				
	Circuit 2	Evaporator Refrigerant Pressure	Status	psi gauge			



## Controls Interface

**Table 121. Unit view tabs - detail (continued)**

Tab	System	Control Point Name	Status	Unit	Min	Max	Default
Circuit 2		Evaporator Saturated Refrigerant Temperature	Status	°F (°C)			
Circuit 2		Evaporator Approach Temperature	Status	°F (°C)			
Circuit 2		Evaporator Refrigerant Liquid Level	Status	in (mm)			
Circuit 2		Evaporator Refrigerant Liquid Level Error	Status	in (mm)			
Circuit 2		EXV Percent Open	Status	%			
Circuit 2		EXV Position Steps	Status	steps			
Circuit 2		Differential Refrigerant Pressure	Status	psid			
Circuit 2		Condenser Refrigerant Pressure	Status	psi gauge			
Circuit 2		Condenser Saturated Refrigerant Temperature	Status	°F (°C)			
Circuit 2		Compressor refrigerant Discharge Temperature	Status	°F (°C)			
Circuit 2		Condenser Approach Temperature	Status	°F (°C)			
Circuit 2		Compressor Refrigerant Discharge Superheat	Status	°F (°C)			
Circuit 2		Compressor 2A Oil Pressure	Status	psi gauge			
Circuit 2		Compressor 2A Average Line Current	Status	% RLA			
Circuit 2		Compressor 2A Line 1 Current	Status	% RLA			
Circuit 2		Compressor 2A Line 2 Current	Status	% RLA			
Circuit 2		Compressor 2A Line 3 Current	Status	% RLA			
Circuit 2		Starter 2A Voltage Vab	Status	volts			
Circuit 2		Starter 2A Voltage Vbc	Status	volts			
Circuit 2		Starter 2A Voltage Vca	Status	volts			
Circuit 2		Compressor 2A Power Consumption	Status	kW			
Circuit 2		Compressor 2A Power Factor	Status				
Circuit 2		Modulation Unload Steady Command	Status				
Circuit 2		Condenser Air Flow	Status	% of fan deck			
Circuit 2		Condenser Inverter Speed	Status	% of inverter full speed			
Circuit 2		Average Condenser Approach Temperature	Status	Diff Temp °F (°C)			
Circuit 2		Re-initialize Average Condenser Approach Temperature	Setting				
Circuit 2		Compressor 2A Average Oil Pressure Drop	Status	% of System DP			
Circuit 2		Re-initialize Compressor 2A Average Oil Pressure Drop	Setting				
Circuit 2		Compressor 2A Oil Filter Life Remaining	Status	%			
Circuit 2		Re-initialize Compressor 2A Oil Filter Life Remaining	Setting				
Circuit 2		Time Remaining Until Oil Analysis Recommended	Status	Hrs			
Circuit 2		Re-initialize Oil Time Remaining	Setting				
<b>Override &amp; Lockouts</b>							
Circuit 1		Restart Inhibit Time - Compressor 1A	Status	mins:secs			
Circuit 1		Restart Inhibit Time - Compressor 2A	Status	mins:secs			
Manual Overrides		Clear Restart Inhibit	Setting				
Manual Overrides		Evaporator Water Pump Override	Setting				Auto
Chiller		Evaporator Water Pump Override Time Remaining	Status	mins:secs			
Manual Overrides		Condenser Water Pump Override	Setting				Auto
Chiller		Condenser Water Pump override Time Remaining	Status	mins:secs			
Circuit 1		EXV Control override	Setting				
Circuit 1		Manual EXV Position Command	Setting	%	0	100	

## Controls Interface

**Table 121. Unit view tabs - detail (continued)**

Tab	System	Control Point Name	Status	Unit	Min	Max	Default
Circuit 1		Evaporator Refrigerant Liquid Level	Status	in (mm)			
Circuit 1		EXV Percent Open	Status	%			
Circuit 1		EXV Position Steps	Status	steps			
Circuit 1		Evaporator Approach Temperature	Status	°F (°C)			
Circuit 1		Differential Refrigerant Pressure	Status	psid			
Circuit 2		EXV Control Override	Setting				Auto
Circuit 2		Manual EXV Position Command	Setting	%	0	100	
Circuit 2		Evaporator Refrigerant Liquid Level	Status	in (mm)			
Circuit 2		EXV Percent Open	Status	%			
Circuit 2		EXV Position Steps	Status	steps			
Circuit 2		Evaporator Approach Temperature	Status	°F (°C)			
Circuit 2		Differential Refrigerant Pressure	Status	psid			
Manual Overrides		Compressor 1A Pumpdown Command	Setting				
Manual Overrides		Compressor 1A Pumpdown Status	Status	°F (°C)			
Manual Overrides		Compressor 2A Pumpdown Command	Setting				
Manual Overrides		Compressor 2A Pumpdown Status	Status	°F (°C)			
Circuit 1		Evaporator Refrigerant Pressure	Status	psi gauge			
Circuit 2		Evaporator Refrigerant Pressure	Status	psi gauge			
Chiller		Keypad Lockout	Setting				Normal
Chiller		CHRV Head Pressure Control Override	Setting				Auto
Manual Overrides		Manual Staging (Stepping Control)	Setting				
Chiller		Manual Staging (Stepping Control Command)	Status				
Manual Overrides		Manual Capacity (Modulation Control)	Setting	%			
Chiller		Manual Capacity Modulation Control Command	Status	%	-100	100	
Circuit 1		Compressor 1A Load Step	Status				
Circuit 1		Compressor 1A% Duty Cycle Sent	Status	%			
Circuit 1		Compressor 1A Average Line Current	Status	% RLA			
Circuit 2		Compressor 2A Load Step	Status				
Circuit 2		Compressor 2A % Duty Cycle Sent	Status	%			
Circuit 2		Compressor 2A Average Line Current	Status	% RLA			
Chiller		Evaporator Leaving Water Temperature	Status	°F (°C)			
Chiller		Evaporator Entering Water Temperature	Status	°F (°C)			
Chiller		"Service Recommended" Messages	Setting				
<b>Feature Settings</b>							
Chiller		Cooling Low Ambient Lockout	Setting				Disable
Chiller		Cooling Low Ambient Lockout Temperature	Setpoint	°F (°C)	-9.94 (-23.3)	70 (21.11)	54.86 (12.7)
Chiller		Differential to Start	Setpoint	°F (°C)	0.5 (.278)	10 (5.55)	2 (1.1)
Chiller		Differential to Stop	Setpoint	°F (°C)	0.5 (.278)	10 (5.55)	2 (1.1)
Chiller		Staging Sequence	Setting				Staging Seq
Chiller		Power-Up Start Delay	Setting	sec	0	600	0
Chiller		Local Stop Delay	Setting	sec	0	30	0
Chiller		Capacity Control Softload Time	Setting	sec	0	7200	900
Chiller		Current Limit Control Softload Time	Setting	sec	0	7200	600



## Controls Interface

**Table 121. Unit view tabs - detail (continued)**

Tab	System	Control Point Name	Status	Unit	Min	Max	Default
Chiller		Current Limit Softload Start Point	Setting	%	20	100	40
Chiller		Variable Evaporator Water Flow Compensation	Setting				Disable
Chiller		Evaporator Pump Off Delay	Setting	minutes	0	30	1
Chiller		Condenser Pump Off Delay	Setting	minutes	0	30	1
Chiller		Condenser Water Pump Pre-Run Tim	Setting	minutes	0	30	0
Chiller		Low Evaporator Leaving Water Temperature Cutout	Setting	°F (°C)	5 (-15)	36 (2.22)	36 (2.22)
Chiller		Low Refrigerant Temperature Cutout	Setting	°F (°C)	-5 (-20.55)	36 (2.22)	28.6 (-1.89)
Chiller		High Evaporator Water Temperature Cutout	Setting	°F (°C)	80 (26.67)	150 (65.56)	105 (40.55)
Chiller		Local Atmospheric Pressure	Setting	psia	68.9	110.3	101.35
Chiller		Ice Building Feature	Setting				Enable
Chiller		External Chilled (Hot Water Setpoint Enable	Setting				Enable
Chiller		External Current Limit Setpoint Enable	Setting				Enable
Chiller		Under (Over Voltage Protection Enable	Setting				Enable
Chiller		LCI-C Diagnostic Language	Setting				English
Chiller		LCI-C diagnostic Encoding	Setting				Text
Chiller		Head Relief Relay Filter Time	Setting	sec	0	1200	600
Chiller		Limit Relay Filter Time	Setting	sec	0	1200	600
Chiller		Maximum Capacity Relay Filter Time	Setting	sec	0	1200	600
<b>Gains</b>							
Chiller		Cooling Design Delta Temperature (Waterside)	Setting	°F (°C)	3.6 (2)	32.4 (18)	10 (5.55)
Chiller		Heating Design Delta Temperature (Waterside)	Setting	°F (°C)	3.6 (2)	32.4 (18)	10 (5.55)
Chiller		Condenser Pressure Limit Setpoint	Setting	%	80	120	90
Chiller		Carryover Maximum Capacity Limit Setpoint	Setpoint	%	50	500	500
Chiller		Carryover Maximum Capacity Limit Kp	Setting		0.03	2.0	.2
Chiller		Carryover Maximum Capacity Limit Ti	Setting	sec	0.1	500	3
Chiller		Carryover Maximum Capacity Limit - Input Type	Setting				
<b>Condenser Head Pressure Control</b>							
Chiller		Head Pressure Control Coverride	Setting				Auto
Chiller		Off State Output Command	Setting	volts	0	10	2
Chiller		Output Voltage at Desired Minimum Flow	Setting	volts	0	10	2
Chiller		Desired Minimum Flow	Setting	%	0	100	20
Chiller		Output Voltage at Desired Maximum Flow	Setting	volts	0	10	10
Chiller		Actuator Stroke Time	Setting	sec	1	1000	30
Chiller		Damping Coefficient	Setting		0.1	1.8	0.5
Chiller		Condenser Water Pump Pre-Run Time	Setting	minutes	0	30	0
Chiller		Condenser Water Pump Pre-Run Time Remaining	Status	mins:secs			
Chiller		Head Pressure Control Output	Status	%			
Chiller		Time Till Actuator at Position	Status	mins:secs			
Chiller		Time to Safe Start of Cond Wtr Pump	Status	mins:secs			
<b>Starts &amp; Hours</b>							
Chiller		Chiller Running Time	Status	hrs:mins			
Circuit 1		Compressor 1A Running Time	Status	hrs:mins			
Circuit 1		Compressor 1A Starts	Status				
Circuit 1		Revise Compressor 1A Run Time	Setting	hrs:mins			
Circuit 1		Revise Compressor 1A Starts	Setting	starts	0	4294967295	
Circuit 2		Compressor 2A Running Time	Status	hrs:mins			
Circuit 2		Compressor 2A Starts	Status				



## Controls Interface

**Table 121. Unit view tabs - detail (continued)**

Tab	System	Control Point Name	Status	Unit	Min	Max	Default
Circuit 2		Revise Compressor 2A Run Time	Setting	hrs:mins			
Circuit 2		Revise Compressor 2A Starts	Setting	starts	0	4294967295	
<b>Date Recorder</b>							
Chiller		Data Recorder Enable/Disable	Setpoint				
Chiller		Data Recorder Change Delta	Setpoint		0	1.0	0.2
Chiller		Data Recorder Sample Period	Setpoint	Sec	1	3600	2
Chiller		Data Recorder Temperature Change Delta	Setpoint	Delta Temp (°C)	0	2.8	0.6
Chiller		Data Recorder Pressure Change Delta	Setpoint	Delta Press (kPa)	0	34.5	13.8
Chiller		Data Recorder Percent Change Delta	Setpoint	%	0	5	1
Chiller		Data Recorder Count Change Delta	Setpoint		0	120	30
<b>Chilled Water Reset</b>							
Chiller		Chilled Water Reset Type	Setpoint				Disable
Chiller		Return Water Reset Ratio	Setpoint	%	10	120	50
Chiller		Return Water Start Reset	Setpoint	°F (°C)	36 (2.22)	62 (16.67)	42 (5.56)
Chiller		Return Water Maximum Reset	Setpoint	°F (°C)	32 (0)	52 (11.11)	37 (2.78)
Chiller		Outdoor Air Reset Ratio	Setpoint	%	-80	80	10
Chiller		Outdoor Air Start Reset	Setpoint	°F (°C)	50 (10)	130 (54.44)	90 (32.22)
Chiller		Outdoor Air Maximum Reset	Setpoint	°F (°C)	32 (0)	52 (11.11)	37 (2.78)
Chiller		Actual Degrees of Chilled Water Reset	Status	°F (°C)			
<b>Chiller I/O States</b>							
Chiller		Evaporator Water Pump Command	Status				
Chiller		Condenser Water Pump Command	Status				
Chiller		Ice Building Active	Status				
<b>Circuit 1 I/O States</b>							
Circuit 1		Compressor 1A Load Step	Status				
Circuit 1		Oil Return Pump Drain	Status				
Circuit 1		Oil Return Pump Drain	Status				
Circuit 1		Optical Oil Sensor Input	Status				
<b>Circuit 2 I/O States</b>							
Circuit 2		Compressor 2A Load Step	Status				
Circuit 2		Oil Return Pump Drain	Status				
Circuit 2		Oil Return Pump Drain	Status				
Circuit 2		Optical Oil Sensor Input	Status				

The items that can be modified show up in white. The items that cannot be modified show up in gray.

**Figure 57. Fields in white**

System	Control Point Name	Value	Unit
Chiller	Front Panel Cool/Heat Command	Cool	
Chiller	Front Panel Chilled Water Setpoint	45.0	*F
Chiller	Front Panel Hot Water Setpoint	90.0	*F
Chiller	Front Panel Current Limit Setpoint	120	%
Chiller	Setpoint Source	BAS/ExtFP	
Chiller	Active Chilled Water Setpoint	45.0	*F
Chiller	Chilled Water SoftLoad Target	45.0	*F
Chiller	Active Hot Water Setpoint	90.0	*F

To change the setpoint, enter a new value for the setpoint into the text field.

**Figure 58. Change setpoint**

Chiller	Front Panel Chilled Water Setpoint	45.0	*F
---------	------------------------------------	------	----

If the entered value is outside the given range, the background turns red.

**Figure 59. Change out of range**

Chiller	Front Panel Hot Water Setpoint	90.0	*F
Chiller	Front Panel Current Limit Setpoint	130	%
Chiller	Setpoint Source	BAS/ExtFP	

If the value entered is not valid, an error message will display and the change will not occur.

**Figure 60. Setpoint change failed**

System	Control Point Name	Value	Unit
Chiller	Front Panel Cool/Heat Command	Cool	
Chiller	Front Panel Chilled Water Setpoint	45.0	*F
Chiller	Front Panel Hot Water Setpoint	90.0	*F
Chiller	Front Panel Current Limit Setpoint	120	%
Chiller	Setpoint Source	BAS/ExtFP	
Chiller	Active Chilled Water Setpoint	45.0	*F
Chiller	Chilled Water SoftLoad Target	45.0	*F
Chiller	Active Hot Water Setpoint		*F
Chiller	Hot Water SoftLoad Target		*F
Chiller	Active Current Limit Setpoint		%
Chiller	Current Limit Setpoint		%
Chiller	Outdoor Air Temperature		*F
Chiller	Evaporator Leaving Water Temperature		*F

**Message** [X]

Setpoint Change Failed.

OK

**Status View**

Status View displays, in real time, all non-setpoint data organized by subsystem tabs. As data changes on the chiller, it is automatically updated in Status View.

## Controls Interface

Figure 61. Status view

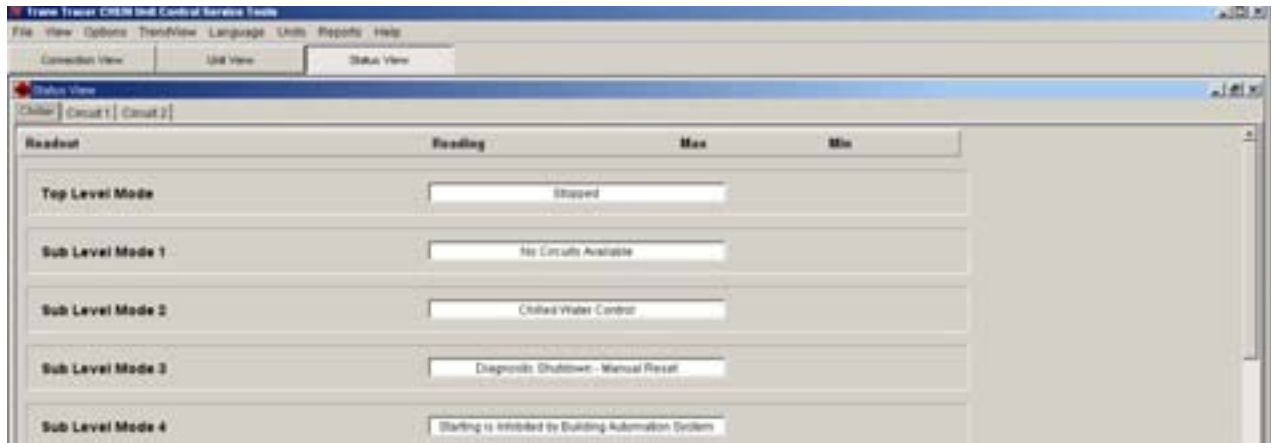

Table 122. Status view tab - detail

Tab	Control Point Name	Units
Chiller	Front Panel Auto Stop Command	
	Local Atmospheric Pressure	psia
	Application Software Revision	
	Keypad Lockout	
	Local Stop Delay	sec
	Top Level Mode	
	Sub Level Mode 1	
	Sub Level Mode 2	
	Sub Level Mode 3	
	Sub Level Mode 4	
	Sub Level Mode 5	
	Sub Level Mode 6	
	Unit Running Powered Indicator	
	MMR	
	MAR	
	IFW	
	Chiller Running Time	hrs:mins
	Active Chiller Auto/Stop Command	
	Setpoint Source Manual Override Exists	
	Power-Up Start Delay	sec
	Outdoor Air Temperature	°F (°C)
	Cooling Low Ambient Lockout	
	Cooling Low Ambient Lockout Temperature	°F (°C)
	Chiller Mode at Time of Last Diagnostic	°F (°C)
	Chiller Sub Mode 1 at Time of Last Diagnostic	
	Chiller Sub Mode 2 at Time of Last Diagnostic	
	Chiller Sub Mode 3at Time of Last Diagnostic	
	Chiller Sub Mode 4 at Time of Last Diagnostic	
	Chiller Sub Mode 5 at Time of Last Diagnostic	

Table 122. Status view tab - detail (continued)

Tab	Control Point Name	Units
Chiller	Chiller Sub Mode 6 at Time of Last Diagnostic	
	Front Panel Current Limit Setpoint	%
	Active Current Limit Setpoint	%
	Active Current Limit Setpoint Source	
	<b>Current Limit SoftLoad Target</b>	<b>%</b>
	<b>Average Percent RLA</b>	<b>% RLA</b>
	<b>Low Evaporator Leaving Water Temperature Cutout</b>	<b>°F (°C)</b>
	<b>Evaporator Entering Water Temperature</b>	<b>°F (°C)</b>
	<b>Evaporator Leaving Water Temperature</b>	<b>°F (°C)</b>
	<b>Front Panel Cool/Heat Command</b>	
	<b>Staging Sequence</b>	
	<b>Cooling Design Delta Temperature (Waterside)</b>	<b>°F (°C)</b>
	<b>Heating Design Delta Temperature (Waterside)</b>	<b>°F (°C)</b>
	<b>Differential to Start</b>	<b>°F (°C)</b>
	<b>Differential to Stop</b>	<b>°F (°C)</b>
	<b>Start to Start Delay Time</b>	
	<b>Capacity Control Debug State</b>	
	<b>Active Hot Water Command</b>	
	<b>Capacity Control Source</b>	
	<b>Manual Staging/Stepping Control Command</b>	
	<b>Manual Capacity Modulation Control Command</b>	<b>%</b>
	Variable Evaporator Water Flow Compensation	
	Variable Flow Filtered Result	
	Current Limit Control Softload Time	sec
	Current Limit Softload Start Point	%
	Front Panel Chilled Water Setpoint	°F (°C)
	Front Panel Hot Water Setpoint	°F (°C)

## Controls Interface

**Table 122. Status view tab - detail (continued)**

Tab	Control Point Name	Units
	Capacity Control Softload Time	sec
	Arbitrated Chilled Water Setpoint	°F (°C)
	Active Chilled Water Setpoint Source	
	Active Chilled Water Setpoint	°F (°C)
	Chilled Water Setpoint SoftLoad Target	°F (°C)
	Arbitrated Hot Water Setpoint	°F (°C)
	Active Hot Water Setpoint Source	
	Active Hot Water Setpoint	°F (°C)
	Hot Water Setpoint SoftLoad Target	°F (°C)
	Need to Run Cooling	
	Need to Run Heating	
	Chilled Water Reset Type	
	Return Water Reset Ratio	%
	Return Water Start Reset	°F (°C)
	Return Water Maximum Reset	°F (°C)
	Outdoor Air Reset Ratio	%
	Outdoor Air Start Reset	°F (°C)
	Outdoor Air Maximum Reset	°F (°C)
	Desired Degrees of Reset	°F (°C)
	Actual Degrees of Chilled Water Reset	°F (°C)
	Circulating Pump	
	Evaporator Water Flow Switch Status	
	Evaporator Pump Off Delay	mins:secs
	External Auto Stop	
	Emergency Stop	
	Head Relief Relay Filter Time	sec
	External Chilled Water Setpoint	°F (°C)
	Ext Hot Water Setpoint	
	External Chilled/Hot Water Setpoint Enable	
	External Current Limit Setpoint	
	External Current Limit Setpoint Enable	
	Maximum Capacity Relay Filter Time	sec
	Limit Relay filter Time	sec
	External Hot Water Command	
	High Evaporator Water Temperature Cutout	°F (°C)
	Condenser Entering Water Temperature	°F (°C)
	Condenser Leaving Water Temperature	°F (°C)
	Condenser Pump Off Delay	minutes
	Condenser Water Flow Switch Status	
	Front Panel ice Building Command	
	Front Panel Ice Termination Setpoint	°F (°C)
	Ice Building Feature	
	Active Ice Building Command	
	Active Ice Termination Setpoint	°F (°C)

**Table 122. Status view tab - detail (continued)**

Tab	Control Point Name	Units
	Active Ice Termination Setpoint Source	
	Ice Building Current Limit Setpoint	%
	External Ice Building Input	
	Need to run ice	
	Condenser Elevation	
	Starter Energy Consumption Last Reset	
	Chiller Power Demand	kW
	Chiller Power Demand Time Period	minutes
	Under/Over Voltage Protection Enable	
	CWRV Output Voltage at Desired Maximum Flow	volts
	CWRV 'Off State' Output Command	volts
	CWRV Desired Minimum Flow	%
	CWRV Actuator Stroke Time	sec
	CWRV Damping Coefficient	
	CWRV Head Pressure control Output	%
	CWRV Time Till Actuator at Position	mins:secs
	CWRV Time to Safe Start of Cond Wtr Pump	mins:secs
	CWRV Percent Status	%
	<b>Circuit 1</b>	
	EXV Position Steps	steps
	EXV Percent Open	%
	Front Panel Circuit Lockout	
	Evaporator Refrigerant Liquid Level	in (mm)
	Mode	
	Sub Level Mode 1	
	Sub Level Mode 2	
	Sub Level Mode 3	
	Sub Level Mode 4	
	Sub Level Mode 5	
	Sub Level Mode 6	
	Condenser Refrigerant Pressure	psi gauge
	Condenser Saturated Refrigerant Temperature	°F (°C)
	Evaporator Refrigerant Pressure	psi gauge
	Evaporator Saturated Refrigerant Temperature	°F (°C)
	Circuit Running Powered Indicator	
	Circuit Manual Reset Indicator (CMR)	
	Circuit Auto Reset Indicator (CAR)	
	Circuit Informational Warning Indicator (IFW)	
	Circuit Limit Min Command	
	Differential Refrigerant Pressure	psid
	Compressor 1A Service Pumpdown Status	
	Evaporator Approach Temperature	°F (°C)
	Condenser Approach Temperature	°F (°C)
	Compressor Refrigerant Discharge Superheat	°F (°C)

## Controls Interface

**Table 122. Status view tab - detail (continued)**

Tab	Control Point Name	Units
	Top Level Mode at Last Diagnostic	
	Submode 1 at Last Diagnostic	
	Submode 2 at Last Diagnostic	
	Submode 3 at Last Diagnostic	
	Submode 4 at Last Diagnostic	
	Submode 5 at Last Diagnostic	
	Submode 6 at Last Diagnostic	
	Compressor Lockout	
	Compressor 1A Starts	
	Compressor 1A Running Time	
	Compressor Running Indicator	hrs:mins
	Compressor 1A Load Step	
	Compressor Refrigerant Discharge Temperature	°F (°C)
	Compressor 1A Oil Pressure	psi gauge
	Compressor 1A Line 1 Current	% RLA
	Compressor 1A Line 2 Current	% RLA
	Compressor 1A Line 3 Current	% RLA
	Line 1 Current Amps	amps
	Line 2 Current Amps	amps
	Line 3 Current Amps	amps
	Starter 1A Voltage Vab	volts
	Compressor 1A Average Line Current	% RLA
	Maximum Line Current	%
	Compressor 1A Power Consumption	kW
	Compressor 1A Power Factor	
<b>Circuit 2</b>		
	EXV Command (%)	%
	EXV Position Steps	steps
	EXV Percent Open	%
	Front Panel Circuit Lockout	
	Evaporator Refrigerant Liquid Level	in
	Mode	
	Sub Level Mode 1	
	Sub Level Mode 2	
	Sub Level Mode 3	
	Sub Level Mode 4	
	Sub Level Mode 5	
	Sub Level Mode 6	
	Condenser Refrigerant Pressure	psi gauge
	Condenser Saturated Refrigerant Temperature	°F (°C)
	Evaporator Refrigerant Pressure	psi gauge
	Evaporator Saturated Refrigerant Temperature	°F (°C)
	Circuit Running Powered Indicator	
	Circuit Manual Reset Indicator (CMR)	

**Table 122. Status view tab - detail (continued)**

Tab	Control Point Name	Units
	Circuit Auto Reset Indicator (CAR)	
	Circuit Informational Warning Indicator (IFW)	
	Circuit Limit Min Command	
	Differential Refrigerant Pressure	psid
	Compressor 1A Service Pumpdown Status	
	Evaporator Approach Temperature	°F (°C)
	Condenser Approach Temperature	°F (°C)
	Compressor Refrigerant Discharge Superheat	°F (°C)
	Top Level Mode at Last Diagnostic	
	Submode 1 at Last Diagnostic	
	Submode 2 at Last Diagnostic	
	Submode 3 at Last Diagnostic	
	Submode 4 at Last Diagnostic	
	Submode 5 at Last Diagnostic	
	Submode 6at Last Diagnostic	
	Compressor Lockout	
	Compressor 2A Starts	
	Compressor 2A Running Time	hrs:mins
	Compressor Running Indicator	
	Compressor 2A Load Step	
	Compressor Refrigerant Discharge Temperature	°F (°C)
	Compressor 2A Oil Pressure	psi gauge
	Compressor 2A Line 1 Current	% RLA
	Compressor 2A Line 2 Current	% RLA
	Compressor 2A Line 3 Current	% RLA
	Line 1 Current Amps	amps
	Line 2 Current Amps	amps
	Line 3 Current Amps	amps
	Compressor 2A Average Line Current	% RLA
	Maximum Line Current	%
	Compressor 2A Power Factor	
<b>Manual Overrides</b>		
	Manual Staging/Stepping Control	
	Manual Capacity Modulation Control	
	Evaporator Water Pump Override	
	Condenser Water Pump Override	
	Compressor 1A service Pumpdown Status	
	Compressor 1A Pumpdown Command	

### Diagnosics View

This window lists the active and inactive (history) diagnostics. There can be up to 60 diagnostics, both active and historic. For example, if there were 5 active diagnostics, the possible number of historic diagnostics would be 55. You can also reset active diagnostics here, (i.e., transfer active diagnostics to history and allow the chiller to regenerate any active diagnostics).

Resetting the active diagnostics may cause the chiller to resume operation.

The Active and History diagnostics have separate tabs. A button to reset the active diagnostics displays when either tab is selected.

**Figure 62. Diagnostic view**

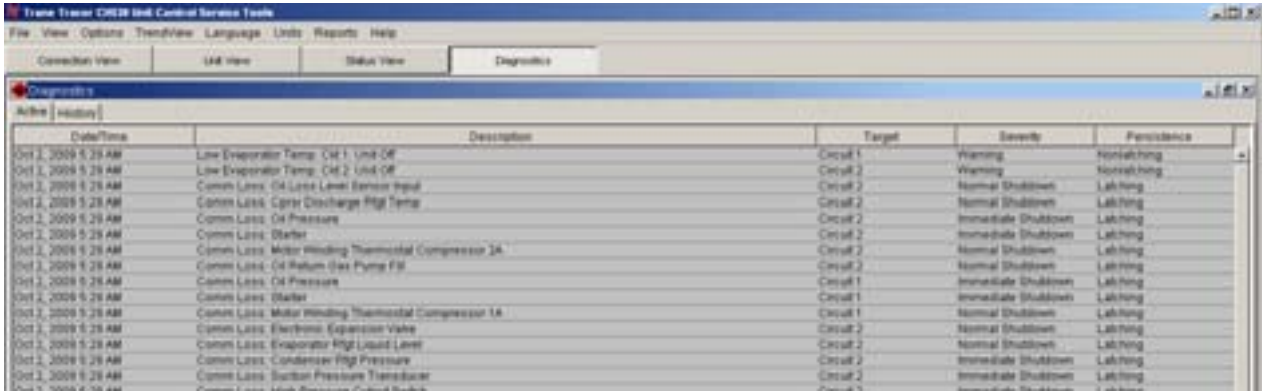

## Configuration View

This view is under the CH530 tab. It displays the active configuration and allows you to make changes to the unit configuration.

**Figure 63. Configuration view - CH530 tab**

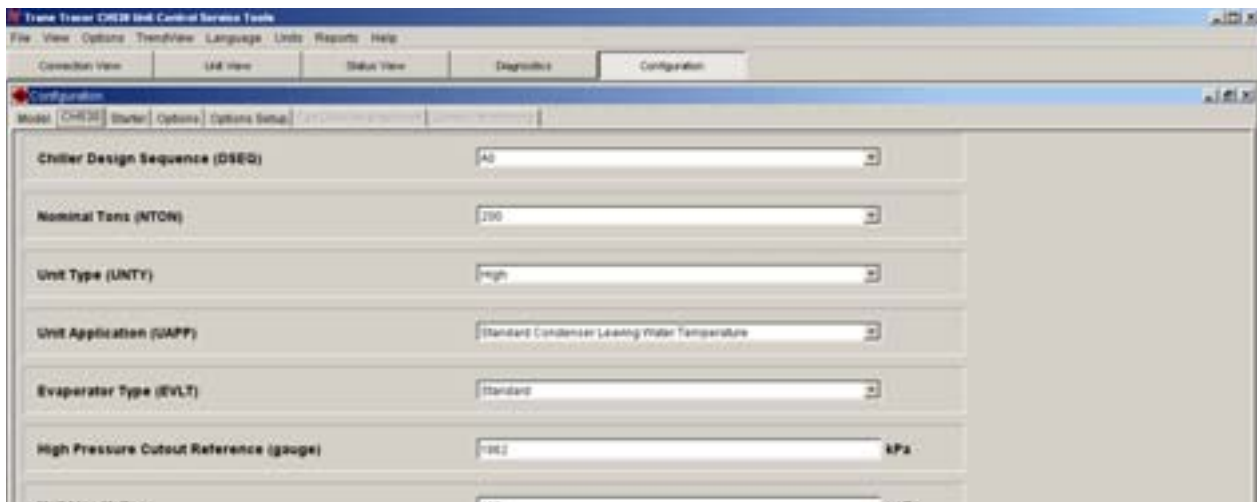

Configuration View allows you to define the chiller's components, ratings, and configuration settings. These are all values that determine the required installed devices, and how the chiller application is run in the main processor. For example, a user may set an option to be installed with Configuration View, which will require devices to be bound using Binding View. And when the main processor runs the chiller application, the appropriate steps are taken to monitor required inputs and control necessary outputs.

Any changes made in the Configuration View, on any of the tabs, will modify the chiller configuration when you click on the Load Configuration button (located at the base of

the window). The Load Configuration button uploads the new configuration settings into the main processor.

Selecting the Undo All button will undo any configuration setting changes made during the present TechView connection and since the last time the Load Configuration button was selected.

**Table 123. Configuration view items - detail**

Tab	Item	Description
Model	Model Type (MODL)	RTWD
		RTUD

## Controls Interface

**Table 123. Configuration view items - detail (continued)**

Tab	Item	Description
	RTWD/CH530 Configuration Control Sequence	1
<b>CH530</b>		
	Chiller Design Sequence (DSEQ)	Factory Assigned
	Nominal Tons (NTON)	60 70 80 90 100 110 120 130 140 150 160 170 180 190 200 220 250
	Unit Type (UNTY)	Standard High Premium
	Unit Application (UAAP)	Standard Condenser Leaving Water Temperature High Temperature Condenser Leaving Water Temperature Water-Water Heat Pump Standard Ambient (Air-Cooled Condenser) High Ambient (Air-Cooled Condenser) No Fan Controls (Water Cooled) Fan Control by Others Integral Fan Controls
	Evaporator Type (EVLTY)	Standard Process Ice
	High Pressure Cutout Reference (gauge)	
	Unit Line Voltage	200V 230V 380V 400V 460V 575V

**Table 123. Configuration view items - detail (continued)**

Tab	Item	Description
	Line Frequency (HRTZ)	50Hz 60Hz
	Manufacturing Location (DCLT)	Curitiba, Brazil Pueblo, USA Charmes, France Taicang, China
	Line Voltage Sensing (WUVO)	Not Installed Installed
	Power Meter (PWRM)	Not Installed Installed
	Water Flow Proving -Factory Installed (FLOW)	115 VAC Paddle Type Flow Switch Factory Installed Low Voltage Thermal Type Flow Switch
<b>Starter</b>		
	Compressor 1A Rated Load Amps	Range = 1 - 999
	Compressor 2A Rated Load Amps	Range = 1 - 999
	Compressor 1A Current Transformer Meter Scale	37.5 Amps 50 Amps 75 Amps 100 Amps 150 Amps 200 Amps 275 Amps 400 Amps 500 Amps 700 Amps 1000 Amps
	Compressor 2A Current Transformer Meter Scale	37.5 Amps 50 Amps 75 Amps 100 Amps 150 Amps 200 Amps 275 Amps 400 Amps 500 Amps 700 Amps 1000 Amps
	Starter Type (SRTY)	Wye-Delta Closed Transition Across the Line
	Contactors Integrity Test	Enable Disable



## Controls Interface

Table 123. Configuration view items - detail (continued)

Tab	Item	Description
	Compressor 1A Frame Size	K1
		K2
		L1
		L2
		M1
		M2
		N1
		N2
	Compressor 2A Frame Size	K1
		K2
		L1
		L2
		M1
		M2
		N1
		N2
	Phase Reversal Protection	Enable
		Disable
	Current Unbalance Trip Point	15 to 90
	Current Unbalance Grace Point	30 to 255
	Starter Panel Forced Ventilation (SPFV)	Not Installed
		Installed
<b>Options</b>		
	Outdoor Air Temperature (OATS)	Not Installed
		Installed
	Ice Building Option (ICEB)	Not Installed
		Installed
		Installed With Hardware Installed Without Hardware
	ECWS/EHWS and External Current Limit Setpoint (SETP)	4-20mA, 2-10Vdc
		Not Installed
	Motor Current Analog Output (CAOA)	Not Installed
		Installed
	Programmable Status Relays (STAT)	Not Installed
		Installed
	Generic Monitoring Package	None
		Installed
	Refrigerant Pressure Output Type (RPOT)	Not Installed
		Installed
		Condenser Pressure in %HPC Differential Pressure

Table 123. Configuration view items - detail (continued)

Tab	Item	Description
	Condenser Leaving Hot Water Temp Control (HWTC)	Condenser Water Regulating Valve Output
		None Hot Water Temperature Control
	BAS Communication/Local Time of Day Schedule (COMM)	Not Installed
		Lontalk Local Time of Day Scheduling BACnet Interface
<b>Options Set Up</b>		
	ECWS Minimum Temperature	-12.22 to 9.9°C
		ECWS Maximum Temperature
	EHWS Minimum Temperature	20 - 60°C
		EHWS Maximum Temperature
	ECLS Minimum%RLA	60
		ECLS Maximum%RLA
	Programmable Status Relay 1 (J2-10,11,12)	None
		Chiller Limit Mode Max Capacity Compressor Running Alarm Latching Alarm Non-Latching Alarm Alarm Circuit 1 Alarm Circuit 2 Circuit 1 Running Circuit 2 Running Head Pressure Relief Request Warning
	Programmable Status Relay 2 (J2-7,8,9)	None
		Chiller Limit Mode Max Capacity Compressor Running Alarm Latching Alarm Non-Latching Alarm Alarm Circuit 1 Alarm Circuit 2 Circuit 1 Running Circuit 2 Running Head Pressure Relief Request



## Controls Interface

**Table 123. Configuration view items - detail (continued)**

Tab	Item	Description
		Warning
	Programmable Status Relay 3 (J2-4,5,6)	None
		Chiller Limit Mode
		Max Capacity
		Compressor Running
		Alarm
		Latching Alarm
		Non-Latching Alarm
		Alarm Circuit 1
		Alarm Circuit 2
		Circuit 1 Running
		Circuit 2 Running
		Head Pressure Relief Request
		Warning
	Programmable Status Relay 4 (J2-1,2,3)	None
		Chiller Limit Mode
		Max Capacity
		Compressor Running
		Alarm
		Latching Alarm
		Non-Latching Alarm
		Alarm Circuit 1
		Alarm Circuit 2
		Circuit 1 Running
		Circuit 2 Running
		Head Pressure Relief Request
		Warning
	Low Ambient Fan Control Type	None
		Variable Speed Fan with Analog Interface
		Two Speed Fan
<b>Fan Deck Arrangement</b>		
	Fan Deck Arrangement Circuit 1 (FDA1)	1 Fan (1H00)
		2 Fans (1H10)
		3 Fans (1H11)
		3 Fans-type 2 (1H20)
		4 Fans (1H12)
		5 Fans (1H13)
		5 Fans-type 2 (1112)
		6 Fans (2H22)
		6 Fans-type 2 (1212)
		7 Fans-type 2 (1123)
		8 Fans-type 2 (1124)

**Table 123. Configuration view items - detail (continued)**

Tab	Item	Description
	Fan Deck Arrangement Circuit 1 (FDA2)	1 Fan (1H00)
		2 Fans (1H10)
		3 Fans (1H11)
		3 Fans-type 2 (1H20)
		4 Fans (1H12)
		5 Fans (1H13)
		5 Fans-type 2 (1112)
		6 Fans (2H22)
		6 Fans-type 2 (1212)
		7 Fans-type 2 (1123)
		8 Fans-type 2 (1124)
<b>Generic Monitoring</b>		
	Monitoring Temperature Sensors	0 - 8
	Monitoring Pressure Transducers	0 - 8
	Monitoring Dual Current Loop Input Modules	0 - 4
	Monitoring Dual Low Voltage Binary Input Modules	0 - 4
	Monitoring Dual High Voltage Binary Input Modules	0 - 4

A couple of additional tabs in Configuration View allow you to change other unit configuration options using the Options tab and the Options Setup Tab. The features that are installed on the Options Tab will control what is displayed on the Options Setup Tab.

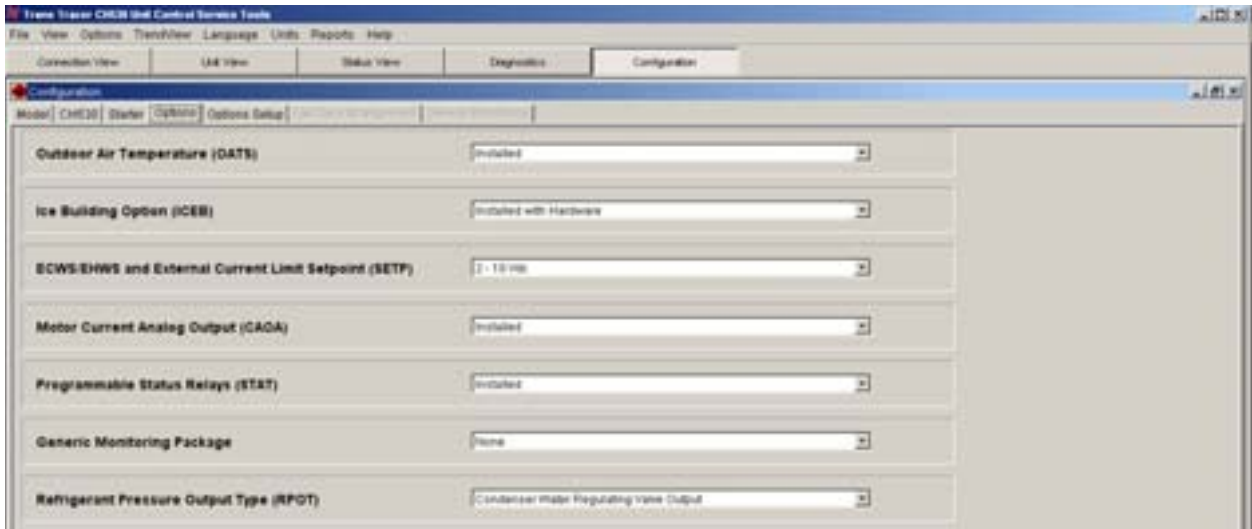
**Figure 64. Configuration view - options tab**

### Software View

Software view allows you to verify the version of chiller software currently running on the DynaView and download a new version of chiller software to the DynaView.

You can also add up to two available languages to load into the DynaView. Loading an alternate language file allows the DynaView to display its text in the selected alternate language, English will always be available.

**Figure 65. Software view**

### Binding View

Binding View allows you to assess the status of the network and all the devices connected as a whole, or the status of individual devices by using status icons and function buttons.

Binding View is essentially a table depicting what devices and options are actually discovered on the network bus (and their communication status) versus what is required to support the configuration defined by the feature codes and categories. Binding View allows you to add, remove, modify, verify, and reassign devices and options in order

to match the configuration requirements. Whenever a device is installed, it must be correctly configured to communicate and to function as intended. This process is called binding. Some features of Binding View are intended to serve a second purpose; that is diagnosing problems with communication among the devices

## Controls Interface

Figure 66. Binding view



### Replacing or Adding Devices

If a device is communicating but incorrectly configured, it might not be necessary to replace it. If the problem with the device is related to communication, attempt to rebind it, and if the device becomes correctly configured, it will then communicate properly.

If a device that needs to be replaced is still communicating, it should be unbound. Otherwise, it will be necessary to rebuild the CH530 network image for Binding View to discover that it has been removed. An unbound device stops communicating and allows a new device to be bound in its place.

It is good practice to turn the power off while detaching and attaching devices to the CH530 network. Be sure to keep power on the service tool computer. After power is restored to the CH530 network, the reconnect function in Binding View restores communication with the network. If

the service tool computer is turned off, you must restart TechView and Binding View.

If a device is not communicating, the binding function displays a window to request manual selection of the device to be bound. Previously-selected devices are deselected when the function starts. When manual selection is confirmed, exactly one device must be selected; if it is the correct type, it is bound. If the desired device cannot be selected or if multiple devices are accidentally selected, you can close the manual selection window by clicking on No and repeat the bind function.

### Fan Configurations

The configurations discussed below are accessible using TechView Service Tool – View - Configurations, and only applicable for Unit Type (MODL) configuration = RTUD. Conversely, the following configuration items are not visible if Unit Type (MODL) is set to = RTWD.

Figure 67. Fan configurations - RTUD

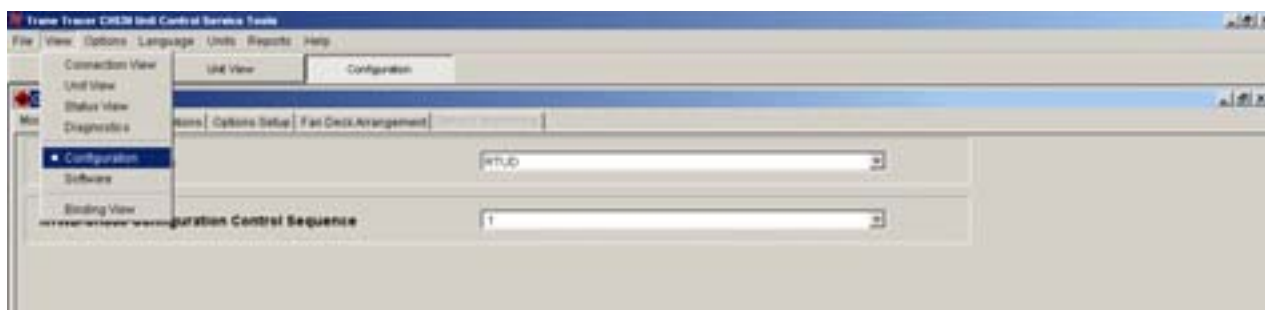

### A/C Fan Controls

This configuration item is used to define the RTUD fan control type including alternate operation as a water cooled instead of an air cooled condenser.

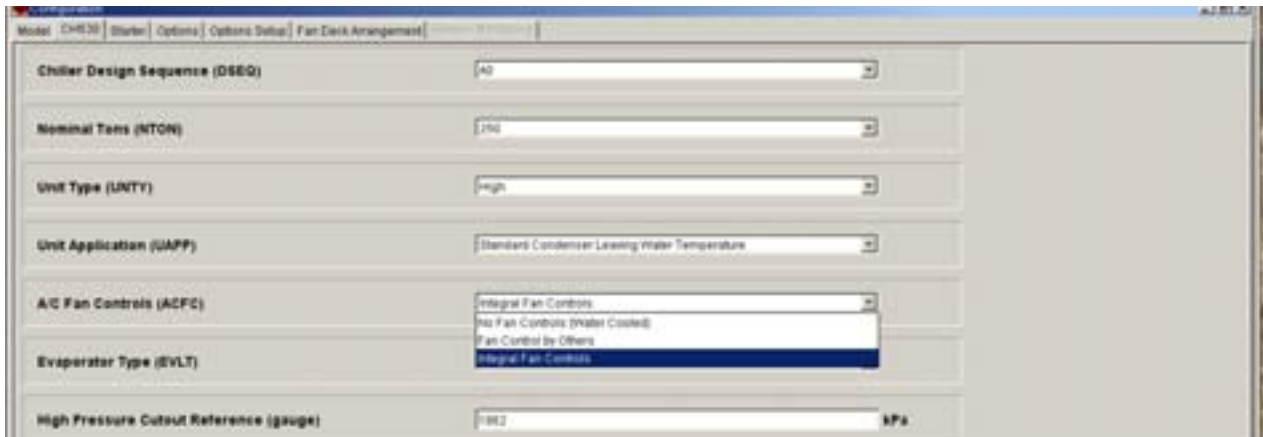
**Figure 68. A/C fan controls - RTUD**

### No Fan Controls (Water Cooled)

If this setting is set to “No Fan Controls (Water Cooled)”, the unit shall be controlled exactly the same as an RTWD unit, that is, that the control logic and sequences will assume that there is a water cooled condenser and condenser water pump control, condenser water flow proving, and circuits start delay times associated with condenser water pump prerun times shall be employed. The DynaView (and TechView) shall display the condenser water temperatures and condenser approach temperatures as defined (although generally a RTUD unit will not ship with condenser water temperature sensors installed and bound) – for proper unit operation as a remote water cooled condenser, the condenser water temperature LLIDs will have to be field installed and bound.

### Fan Control By Others

If this setting is set to “Fan Control By Others”, the first two relays on the “Fan Control Interlock” quad relay output board relays will function as interlock contacts for use as in input to an external pressure or temperature based fan controller on a per circuit basis. Concurrent with the circuit’s EXV pre-position as part of the start sequence of

a given circuit, the respective “fan control interlock” relay for that circuit will energize and close the NO contacts.

The respective relay shall be de-energized to return to its normal state, once the circuit/compressor has stopped. Note that this means the relay shall stay energized until the compressor state is proven to be off.

### Integral Fan Controls

If this setting is set to “Integral Fan Controls,” the fan controls are integral to the CH530 main processor and (depending on the selection for the other fan control configurations - i.e. Fan Deck Arrangement Circuit 1 (FDA1), Fan Deck Arrangement Circuit 2 (FDA2), Low Ambient Fan Control Type (LAFC)) shall control the appropriate relays (and connected fans) and other outputs (variable speed fan outputs and monitor VFD fault inputs) to control the differential pressure per the chiller’s requirements.

### Low Ambient Fan Control Type

Note: Present if A/C Fan Control (ACFC) = Integral Fan Control (INT)

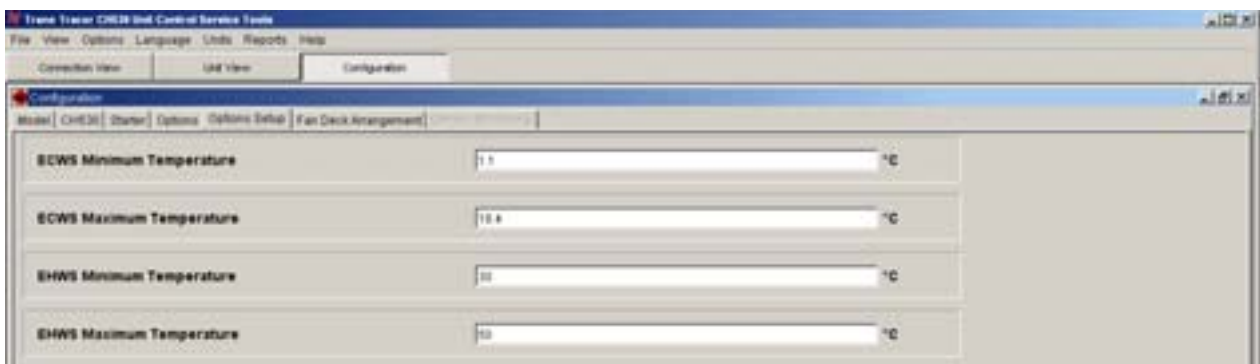
**Figure 69. Low ambient fan control type**

## Controls Interface

If this setting is set to “None,” fan control shall be per the full speed fixed speed fan tables with each circuit applying the Fan Deck Arrangement configuration selected below.

If this setting is “Two Speed Fan” (TSPD), fan control shall provide for the first fan to be a two speed fan and control and the first two relays of the quad relay shall be used for low and high speed control of that fan. The Two-speed fan operation, assumes the use of fans and contactors designed for Wye (low speed) and Delta (high speed) motor connections and the ratio of the low to high speed cfm is approximately 80%. For Two-Speed fan configurations, low to high and high to low speed transitions are subject to a 5 second delay with neither the low speed nor the high speed contacts being energized. The low speed contact generally refers to relay 1 and the high speed contact generally refers to relay 2.

**Note:** When selecting two speed fan control for the low ambient option, only the Fan Deck Arrangements with an “H” in the 2nd position of the fan grouping definition are supported.

If this setting is “Variable Speed Fan with Analog Interface” VARA, the fan control shall operate fixed speed fans as well as a single inverter driven fan, and the controls include the enabling and speed command signals to this variable speed inverter. The inverter shall have an analog interface and fault feedback and be similar to the DanFoss TR1 2800 series inverter.

For variable speed fan decks, the first relay controls the variable frequency drive, through an enable/disable input of the inverter. The Variable speed fan option supports an inverter fault input to monitor the fault state of the inverter. An inverter fault or other inverter-related diagnostic causes the fan control to de-energize the inverter relay, command a zero percent speed via the analog speed command interface, and reverts to a special fixed-speed fan control mode.

In normal operation (no inverter diagnostics), the inverter is not commanded to zero-speed unless all other fans are commanded off. During normal operation, a minimum inverter speed command is enforced to prevent counter-rotation of the inverter driven fan. Counter-rotation can reduce fan deck capacity and negatively affect reliability of inverters and its fans.

### Variable Speed Analog Fans

Each independently controlled variable speed fan has three I/O points:

- A fan deck relay controls the inverter run/stop command state. (Inverter power is continuously applied and not controlled by a contactor.)
- A 0-10 Volt analog output commands the variable frequency drive’s speed.

Output Voltage [V] = Desired VFD Speed [%] /10, with a minimum Desired VFD Speed of 7% (0.7V).

To send a reset command, 0% (0.0V) is sent.

- A binary input senses inverter faults.

The Fan Inverter Fault LLID binary input expects to see and open-circuit (i.e open dry contact) on its respective input terminals when the inverter is de-energized or when an inverter fault is present.

The Fan Inverter Fault LLID binary input expects to see a closed circuit (i.e. closed dry contact) when the inverter is energized and no faults are active.

The inverter fault diagnostic is not activated until 5 seconds after the inverter Run/Stop command relay is energized.

### Fan Deck Arrangement Circuit 1

**Note:** Present if A/C Fan Control (ACFC) = Integral Fan Control (INT)

**Figure 70. Fan deck arrangement**

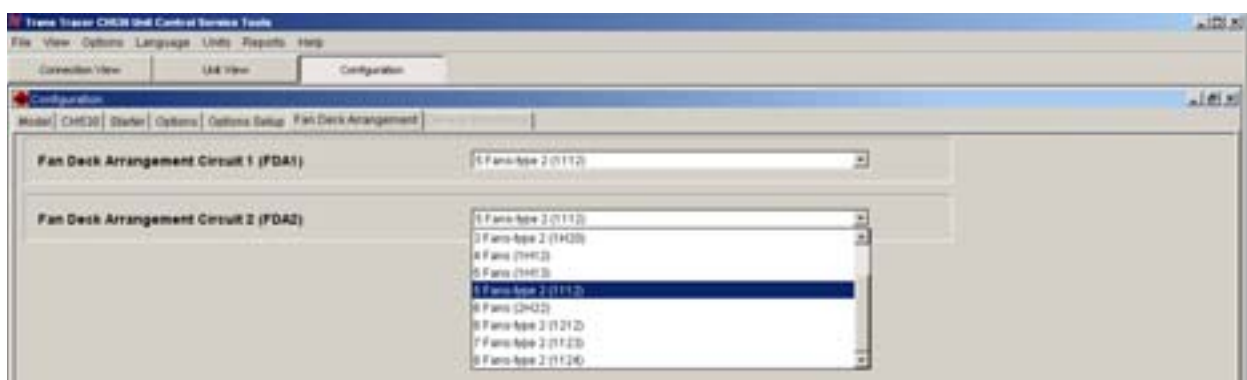

This setting defines the wiring of the four fan relays outputs of the Fan Control Relay LLID for the respective circuit (circuit 2’s setting is shown above). It indicates the fan grouping in terms of how many fans each particular relay is expected to control. The numbers in parentheses

refer to the number of fans controlled by each of the 4 relays in order (lowest terminal number designators first). “H” means reserved for high speed of 2 speed fan, if applicable - if no two-speed fan selected in LAFC, then “H” implies no fans wired to this relay.

## Fan Deck Arrangement Circuit 2

Note: Present if A/C Fan Control (ACFC) = Integral

This setting is the same as above, except for circuit 2. Each circuit may have different fan arrangements, but both must use an identical type of low ambient fan control if applicable.

## Example for Fan Configurations

An air cooled condensing unit is selected that properly matches the capacity of the RTUD unit intended for a comfort cooling application. Lets assume the condenser has 5 fixed speed fans per circuit, and no variable speed fans or two speed fans, since operation below 32F outdoor air ambient temperature is not required.

**Figure 71. Service tool - view configuration**



And then select tab "CH530" and the "A/C Fan Controls" item in that list, select "Integral Fan Controls" for that item:view

**Figure 72. Service tool configuration - integral fan control selection**

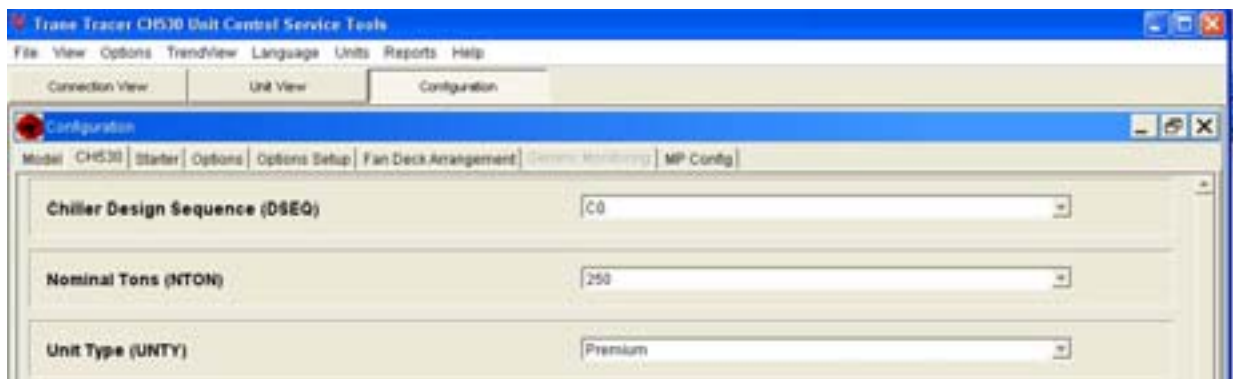

Then proceed to the Tab "Options Setup" and the item Low Ambient Control Type in that list; select "None" for that item. Then proceed to the Fan Deck Arrangement Tab and click on the Fan Deck Arrangement Circuit 1 item. By clicking In the drop down box, you will see a number of supported fan deck arrangements. In the drop down we can see that there are two unique arrangements that support 5 fans total. The first one is designated as "1H13" and the 2nd is "1112".

The RTUD chiller should come factory configured as an RTUD chiller, but the fan configurations will generally need to be set in the field per the condenser selected and installed with the chiller. Using TechView PC based service tool running on a laptop PC or similar, power up the controls on the chiller and connect to the PC using an RS232 cable (connection on the bottom of the CH530 Adaptive Control).

## A/C Fan Controls (ACFC)

Launch TechView and press the "Local Connection" button in the bottom left hand corner. When the connection is completed – proceed to the configurations view

## Controls Interface

**Figure 73. Service tool configuration - fan deck arrangement**

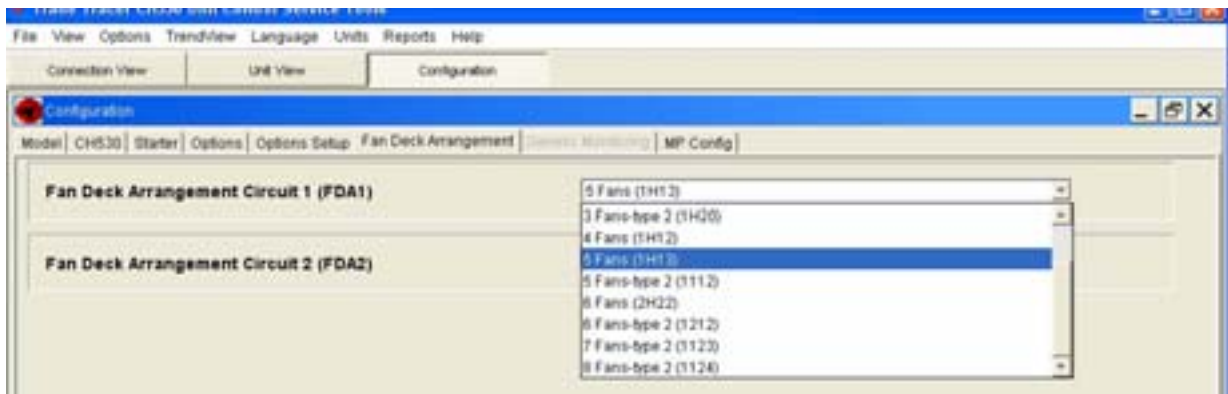

The character in the 4 digit descriptor define the number of fans that are intended to be wired to each of the 4 relays on the respective circuit's quad fan control relay LLID. The first of the two possible 5 fan arrangements uses sequence 1 H 1 3. This sequence implies there should be 1 fan wired to relay 1 (terminals J2-1,3 of module 1A25 – Circuit 1 Fan Control module, which are internally wired to the 1X11 terminals 1 & 2). Then next digit in the sequence H, is only for use with the High speed of a 2 speed fan configuration and since “none” was selected for low ambient options, this means it is not to be used and nothing should be wired to the 2nd relay (terminals J2-4,6 1X11 terminals 3 & 4). Likewise, the 3rd and 4th digits imply the number of fans that are to be wired to the 3rd and 4th relays, (the relays being internally wired to the terminal strip 1X11 terminals 5 & 6 and 7 & 8 respectively.)

The second alternative wiring for a fixed speed 5 fan deck is the 1112 selection. In this scheme, the first 3 relays (terminals 1X11 1&2, 3&4, 5&6), should all be wired to control one fan, and the last relay should control 2 fans (1X11 terminals 7 & 8)

**Figure 74. Load configurations**

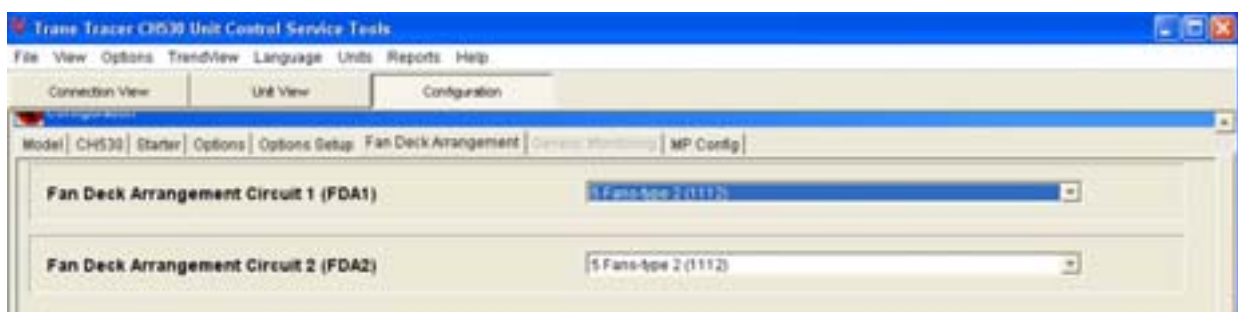

Allow a short time for the configuration to be set and both the CH530 DynaView and TechView to reboot. If new LLIDs and hardware binding for them is required as a result of the configuration just downloaded, TechView will immediately launch the “Binding View” that provides for a list of the required LLIDs and their communication status. Install and bind all new LLIDs as required. Most

Repeat the same selection for circuit 2 by click on the Fan Deck Arrangement Circuit 2 item. In the drop down box, you will see a number of supported fan deck arrangements. Select the appropriate fan deck arrangement for circuit 2. The selection of the arrangement would then define the wiring for module 1A26 – Circuit 2 Fan Control Module and it associated field wiring terminals 1X11 terminals 9 & 10, 11 & 12, 13 & 14, and 15 & 16).

**Note:** The fan deck arrangement does not necessarily have to be the same as Circuit 1, but usually the circuits have the same number of fans and therefore the same arrangement selection is appropriate.

As a last important step, the configurations need to be downloaded to the CH530 DynaView/Main Processor. This is accomplished by clicking on the “Load Configurations” button at the bottom of the configurations screen.

often, however, the proper LLIDs will already be present and bound if the options were appropriately ordered with the chiller.



# Pre-Start Checkout

When installation is complete, but prior to putting the unit into service, the following pre-start procedures must be reviewed and verified correct:

## **⚠ WARNING**

### **Hazardous Voltage!**

**Disconnect all electric power, including remote disconnects before servicing. Follow proper lockout/tagout procedures to ensure the power can not be inadvertently energized. Failure to disconnect power before servicing could result in death or serious injury.**

Note: For any installation violations of this manual, use Non-Compliance form PROD-ADF001-EN.

Note: Verify removal of oil separator shipping spaces as required in Installation-Mechanical chapter. Failure to remove the spacers could result in excessive noise and vibration transmission into the building.

- Inspect all wiring connections to be sure they are clean and tight.
- For RTUD units, verify that unit piping between RTUD and condenser is as described in "Installation-Mechanical" section.
- Verify that all refrigerant valves are "OPEN"

## **NOTICE:**

### **Compressor Damage!**

**Do not operate the unit with the compressor, oil discharge, liquid line service valves and the manual shutoff on the refrigerant supply to the auxiliary coolers "CLOSED". Failure to "OPEN" all valves may cause serious compressor damage.**

- Check the power supply voltage to the unit at the main power fused-disconnect switch. Voltage must be within the voltage utilization range stamped on the unit nameplate. Voltage imbalance must not exceed 2 percent. See "[Unit Voltage Imbalance](#)", p. 169.
- Check the unit power phasing to be sure that it has been installed in an "ABC" sequence. See "[Unit Voltage Phasing](#)", p. 169.

## **⚠ WARNING**

### **Live Electrical Components!**

**During installation, testing, servicing and troubleshooting of this product, it may be necessary to work with live electrical components. Have a qualified licensed electrician or other individual who has been properly trained in handling live electrical components perform these tasks. Failure to follow all electrical safety precautions when exposed to live electrical components could result in death or serious injury.**

- Fill the evaporator and condenser chilled water circuits. Vent the system while it is being filled. Open the vents on the top of the evaporator and condenser during filling and close when filling is completed.

## **NOTICE:**

### **Proper Water Treatment!**

**The use of untreated or improperly treated water could result in scaling, erosion, corrosion, algae or slime. It is recommended that the services of a qualified water treatment specialist be engaged to determine what water treatment, if any, is required. Trane assumes no responsibility for equipment failures which result from untreated or improperly treated water, or saline or brackish water.**

- Close the fused-disconnect switch(es) that supplies power to the chilled water pump starter and the condenser water pump starter.

## **⚠ WARNING**

### **Hazardous Voltage!**

**Disconnect all electric power, including remote disconnects before servicing. Follow proper lockout/tagout procedures to ensure the power can not be inadvertently energized. Failure to disconnect power before servicing could result in death or serious injury.**

- Start the chilled water pump and condenser water pump (RTWD only)
- to begin circulation of the water. Inspect all piping for leakage and make any necessary repairs.
- With water circulating through the system, adjust water flow and check water pressure drop through the evaporator and condenser.
- Adjust the chilled water flow switch and condenser water flow switch (if installed) for proper operation.
- Prove all Interlock and Interlock and External as described in Section "Installation-Electrical"
- Check and set, as required, all CH530 Menu Items.
- Stop the chilled water pump and condenser water pump.



## Pre-Start Checkout

### Unit Voltage Power Supply

#### ⚠ WARNING

##### Live Electrical Components!

During installation, testing, servicing and troubleshooting of this product, it may be necessary to work with live electrical components. Have a qualified licensed electrician or other individual who has been properly trained in handling live electrical components perform these tasks. Failure to follow all electrical safety precautions when exposed to live electrical components could result in death or serious injury.

Voltage to the unit must meet the criteria given in. Measure each leg of the supply voltage at the unit's main power fused-disconnect. If the measured voltage on any leg is not within specified range, notify the supplier of the power and correct the situation before operating the unit.

#### NOTICE:

##### Equipment Damage!

Inadequate voltage to the unit may cause control components to malfunction and shorten the life of relay contact, compressor motors and contactor.

### Unit Voltage Imbalance

Excessive voltage imbalance between the phases of a three-phase system can cause motors to overheat and eventually fail. The maximum allowable imbalance is 2 percent. Voltage imbalance is determined using the following calculations:

$$\% \text{ Imbalance} = \frac{(I_x - I_{ave}) \times 100}{I_{ave}}$$

$$V_{ave} = \frac{(V_1 + V_2 + V_3)}{3}$$

$I_{V_x}$  = phase with greatest difference from  $V_{ave}$  (without regard to sign)

For example, if the three measured voltages are 221, 230, and 227 volts, the average would be:

$$\frac{221 + 230 + 227}{3} = 226$$

The percentage of imbalance is then:

$$\frac{100(221 - 226)}{226} = 2.2\%$$

This exceeds the maximum allowable (2%) by 0.2 percent.

### Unit Voltage Phasing

It is important that proper rotation of the compressors be established before the unit is started. Proper motor rotation requires confirmation of the electrical phase sequence of the power supply. The motor is internally connected for clockwise rotation with the incoming power supply phased A, B, C.

Basically, voltages generated in each phase of a polyphase alternator or circuit are called phase voltages. In a three-phase circuit, three sine wave voltages are generated, differing in phase by 120 electrical degrees. The order in which the three voltages of a three-phase system succeed one another is called phase sequence or phase rotation. This is determined by the direction of rotation of the alternator. When rotation is clockwise, phase sequence is usually called "ABC"; when counterclockwise, "CBA".

This direction may be reversed outside the alternator by interchanging any two of the line wires. It is this possible interchange of wiring that makes a phase sequence indicator necessary if the operator is to quickly determine the phase rotation of the motor.

Proper compressor motor electrical phasing can be quickly determined and corrected before starting the unit. Use a quality instrument, such as the Associated Research Model 45 Phase Sequence Indicator.

1. Press the Stop key on the Clear Language Display.
2. Open the electrical disconnect or circuit protection switch that provides line power to the line power terminal block(s) in the starter panel (or to the unit mounted disconnect).
3. Connect the phase sequence indicator leads to the line power terminal block, as follows:

Phase Sequence Lead	Terminal
Black (Phase A)	L1
Red (Phase B)	L2
Yellow (Phase C)	L3

4. Turn power on by closing the unit supply power fused-disconnect switch.
5. Read phase sequence on indicator. "ABC" LED on the face of the phase indicator will glow if phase is "ABC".
6. If the "CBA" indicator glows instead, open the unit main power disconnect and switch two line leads on the line power terminal block(s) (or the unit mounted disconnect). Reclose the main power disconnect and recheck the phasing.

#### NOTICE:

##### Equipment Damage!

Do not interchange any load leads that are from the unit contactors or the motor terminals.

7. Reopen unit disconnect and disconnect phase indicator.

**⚠ WARNING****Hazardous Voltage!**

**Disconnect all electric power, including remote disconnects before servicing. Follow proper lockout/tagout procedures to ensure the power can not be inadvertently energized. Failure to disconnect power before servicing could result in death or serious injury.**

**Water System Flow Rates**

Establish a balanced chilled water flow through the evaporator. The flow rates should fall between the minimum and maximum values. Chilled water flow rates below the minimum values will result in laminar flow, which reduces heat transfer and causes either loss of EXV control or repeated nuisance, low temperature cutouts. Flow rates that are too high can cause tube erosion.

The flow rates through the condenser must also be balanced. The flow rates should fall between the minimum and maximum values.

**Water System Pressure Drop**

Measure water pressure drop through the evaporator and condenser at the field-installed pressure taps on the system water piping. Use the same gauge for each measurement. Do not include valves, strainers fittings in the pressure drop readings.

Pressure drop readings should be approximately those shown in the Pressure Drop Charts starting with [Figure 21](#), p. 43.

**NOTICE:****Equipment Damage!**

**Ensure that the oil separator and compressor heaters have been operating for a minimum of 24 hours before starting. Failure to do so may result in equipment damage.**

# Unit Start-Up Procedures

## Sequence of Operation

### Power Up

The Power up chart shows the respective DynaView screens during a power up of the main processor. This process takes from 30 to 50 seconds depending on the number of installed Options. On all power ups, the

software model will always transition through the 'Stopped' Software state independent of the last mode. If the last mode before power down was 'Auto', the transition from 'Stopped' to 'Starting' occurs, but it is not apparent to the user.

**Figure 75. Power up**



### Power Up to Starting

The Power up to starting diagram shows the timing from a power up event to energizing the compressor. The shortest allowable time would be under the following conditions:

1. No motor restart inhibit
2. Evaporator Water flowing
3. Condenser Water flowing (RTWD only)
4. Power up Start Delay setpoint set to 0 minutes
5. Adjustable Stop to Start Timer set to 5 seconds
6. Need to cool

The above conditions would allow for a minimum power up to starting compressor time of 95 seconds.

Figure 76. RTWD Power up to starting

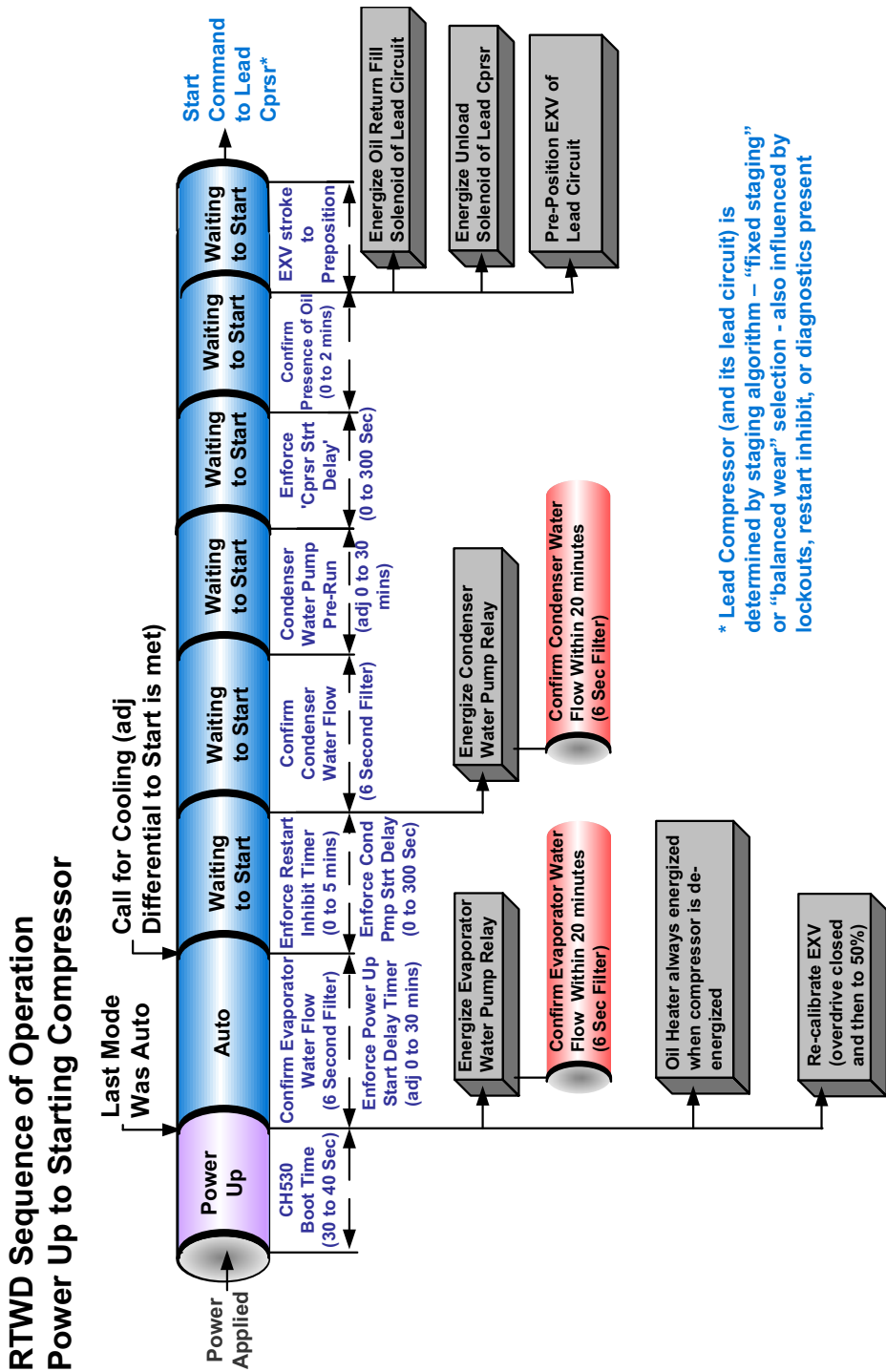

## Unit Start-Up Procedures

---

### Stopped to Starting:

The stopped to starting diagram shows the timing from a stopped mode to energizing the compressor. The shortest allowable time would be under the following conditions:

1. No motor restart inhibit
2. Evaporator and Condenser Water flowing
3. Power up Start Delay Timer has expired
4. Adjustable Stop to Start Timer has expired
5. Need to cool

The above conditions would allow the compressor to start in 60 seconds.

#### **NOTICE:**

##### **Compressor Damage!**

If both suction and discharge pressures are low but sub-cooling is normal, a problem other than refrigerant shortage exists. Do not add refrigerant, as this may result in overcharging the circuit.

Use only refrigerants specified on the unit nameplate (HFC 134a) and Trane OIL00048. Failure to do so may cause compressor damage and improper unit operation.

#### **NOTICE:**

##### **Equipment Damage!**

Ensure that the oil separator and compressor heaters have been operating for a minimum of 24 hours before starting. Failure to do so may result in equipment damage.

Figure 77. RTUD Power up to starting

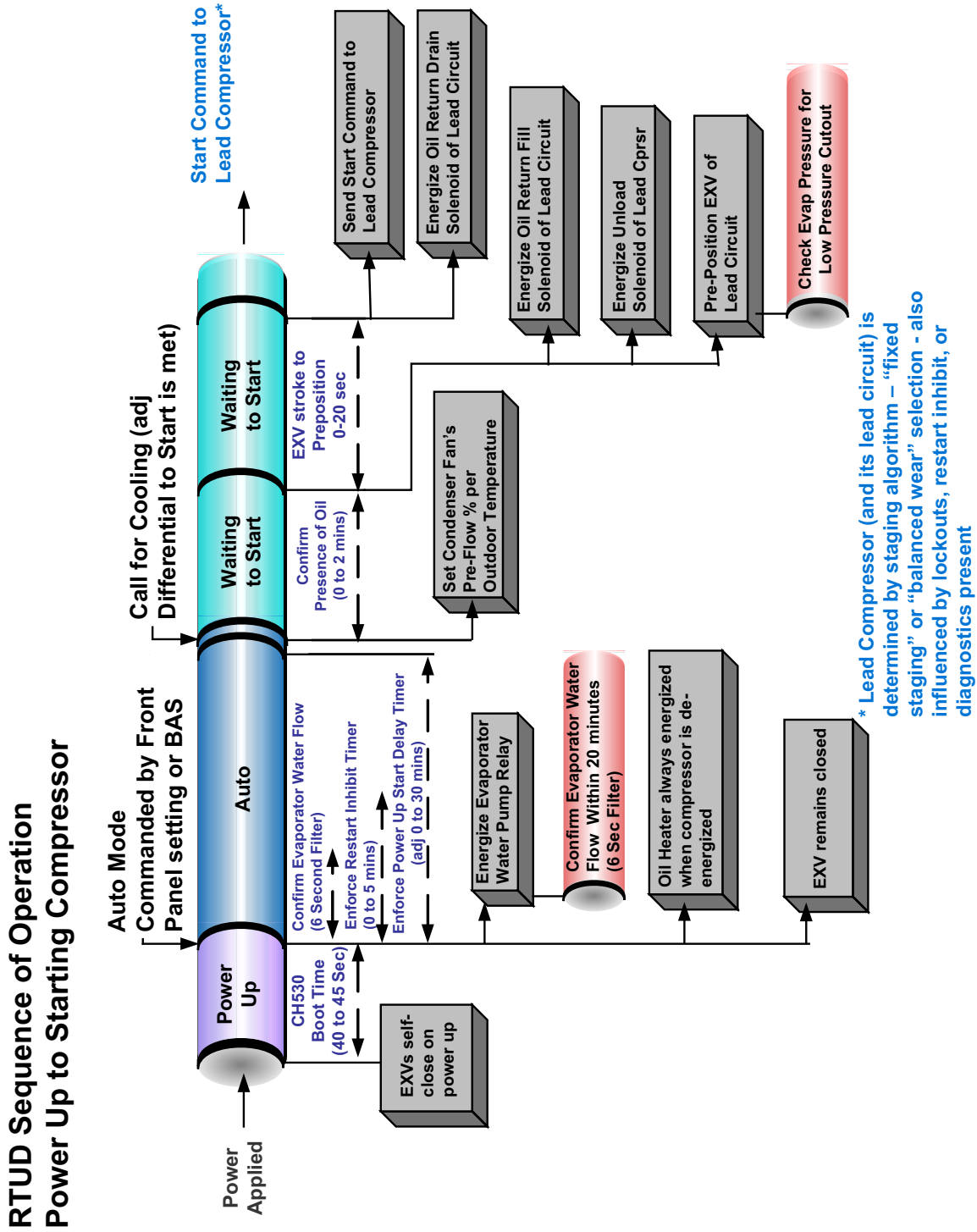

# Unit Start-Up Procedures

Figure 78. RTWD Stopped to starting

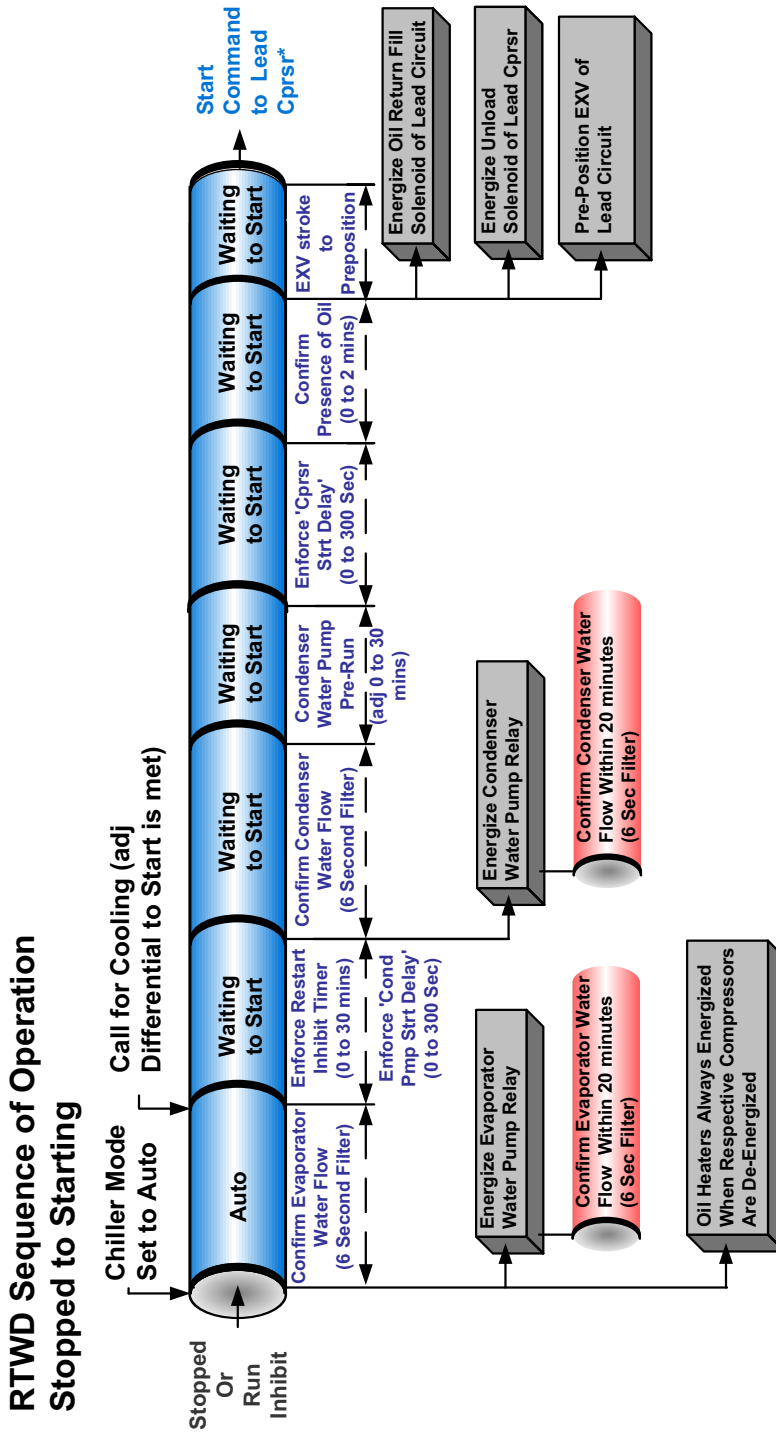

\* Lead Compressor (and its lead circuit) determined by staging algorithm and "fixed staging" or "balanced wear" selection. If "balanced wear" then compressor with least wear (10\* starts + hours) is lead. If "fixed staging" Cprsr 1A is always lead and Cprsr 2A is always lag. Staging order is also influenced by lockouts, restart inhibit, or diagnostics present and will also obey priority staging rule: Any cprsr running but not step loaded, has priority to either step load or to unstage (turn off).

Figure 79. RTUD Stopped to starting

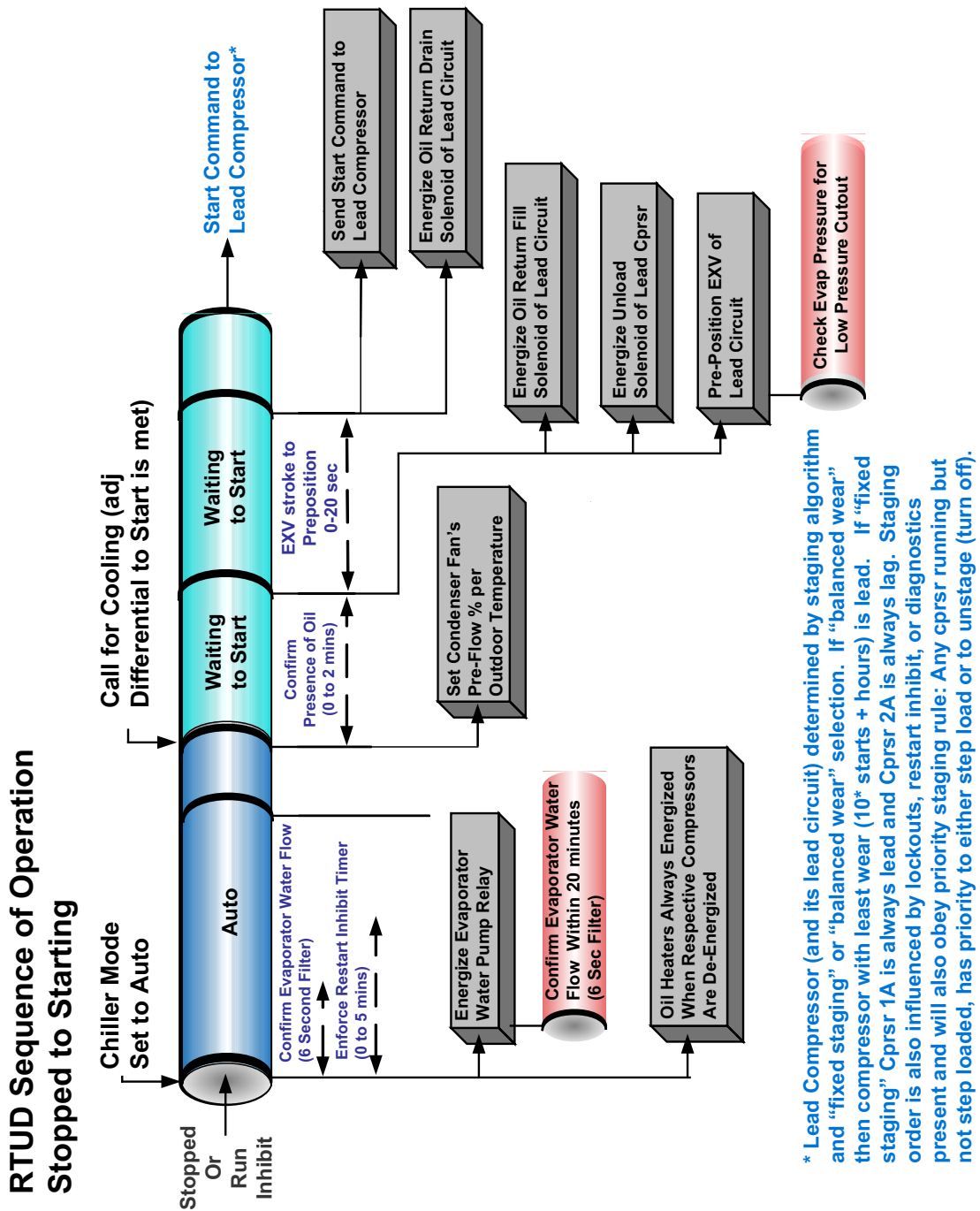



## Unit Start-Up Procedures

### Start-up

#### **NOTICE:**

#### **Equipment Damage!**

**Ensure that the oil separator and compressor heaters have been operating for a minimum of 24 hours before starting. Failure to do so may result in equipment damage.**

If the pre-start checkout, has been completed, the unit is ready to start.

1. Press the STOP key on the CH530.
2. As necessary, adjust the setpoint values in the CH530 menus using TechView.
3. Close the fused-disconnect switch for the chilled water pump. Energize the pump(s) to start water circulation.
4. Check the service valves on the discharge line, suction line, oil line and liquid line for each circuit. These valves must be open (backseated) before starting the compressors.

#### **NOTICE:**

#### **Compressor Damage!**

**Catastrophic damage to the compressor will occur if the oil line shut off valve or the isolation valves are left closed on unit start-up.**

5. Press the AUTO key. If the chiller control calls for cooling and all safety interlocks are closed, the unit will start. The compressor(s) will load and unload in response to the leaving chilled water temperature.
6. Verify that the chilled water pump runs for at least one minute after the chiller is commanded to stop (for normal chilled water systems).

Note: Once the system has been operating for approximately 30 minutes and has become stabilized, complete the remaining start-up procedures, as follows:

7. Check the evaporator refrigerant pressure and the condenser refrigerant pressure under Refrigerant Report on the CH530 TechView. The pressures are referenced to sea level (14.6960 psia).
8. Check the EXV sight glasses after sufficient time has elapsed to stabilize the chiller. The refrigerant flow past the sight glasses should be clear. Bubbles in the refrigerant indicate either low refrigerant charge or excessive pressure drop in the liquid line or a stuck open expansion valve. A restriction in the line can sometimes be identified by a noticeable temperature differential between the two sides of the restriction. Frost will often form on the line at this point. Proper

refrigerant charges are shown in the General Data tables.

Important: A clear sight glass alone does not mean that the system is properly charged. Also check system subcooling, liquid level control and unit operating pressures.

9. Measure the system subcooling.
10. A shortage of refrigerant is indicated if operating pressures are low and subcooling is also low. If the operating pressures, sight glass, superheat and subcooling readings indicate a refrigerant shortage, gas-charge refrigerant into each circuit, as required. With the unit running, add refrigerant vapor by connecting the charging line to the suction service valve and charging through the backseat port until operating conditions become normal.

### Seasonal Unit Start-Up Procedure

11. Close all valves and re-install the drain plugs in the evaporator and condenser heads.
12. Service the auxiliary equipment according to the start-up/maintenance instructions provided by the respective equipment manufacturers.
13. Vent and fill the cooling tower, if used, as well as the condenser and piping. At this point, all air must be removed from the system (including each pass). Close the vents in the evaporator chilled water circuits.
14. Open all the valves in the evaporator chilled water circuits.
15. If the evaporator was previously drained, vent and fill the evaporator and chilled water circuit. When all air is removed from the system (including each pass), install the vent plugs in the evaporator water boxes.
16. Verify condenser coils are clean.

#### **NOTICE:**

#### **Equipment Damage!**

**Ensure that the oil separator and compressor heaters have been operating for a minimum of 24 hours before starting. Failure to do so may result in equipment damage.**

#### **NOTICE:**

#### **Compressor Damage!**

**Catastrophic damage to the compressor will occur if the oil line shut off valve or the isolation valves are left closed on unit start-up.**



## Unit Start-Up Procedures

Figure 80. Start-up log

RTWD/RTUD Start-up Test Log					
Job Name			Job Location		
Model #			Serial #		start date:
Sales Order #		ship date:		Job elevation (ft. above sea level)	
STARTER DATA:			START-UP ONLY		
Manufacturer			Chiller appearance at arrival:		
Type: (x-line, wye-delta)			Machine Gauge Pressure:		psig/ kPag
Vendor ID #/Model #:			Machine CH530 Pressure:		psig/ kPag
Volts	Amps	Hz	Complete if pressure test is required		
COMPRESSOR DATA:			Vacuum after leak test=		
Compressor A: Model #:			Standing vacuum test =		
Compressor A: Serial #:			mm rise in		
Compressor B: Model #:			hrs		
Compressor B: Serial #:			UNIT CHARGES		
NAMEPLATE DATA:			Unit refrigerant charge:		
RLA			KW		Volts
50 60 Hz			Y N Tracer Communications Interface		
DESIGN DATA:			Y N Options Module		
RLA			KW		Volts
CURRENT TRANSFORMER			Y N Outdoor Air Sensor (Required for RTUD)		
Part Number ("X" code and 2-digit extension)			Y N Ice Making Control		
Primary CT's			Y N Other		
X			X		RTUD UNIT VERIFICATION
X			X		Y N Outdoor Air Sensor Cut and Installed at Condenser
X			X		Y N Condenser Elevation Setting Entered - Record Value:
X			X		Y N Chilled Water Pump Control Installed & Verified
X			X		Y N Review Nameplate Model No - Verify Ckts Piped Correctly
DESIGN CONDITIONS					
Evap Design	_____ GPM L/S	_____ PSID	_____ kPad	Ent. Water F/C _____	Leaving Water F/C _____
Evap Actual	_____ GPM L/S	_____ PSID	_____ kPad	Ent. Water F/C _____	Leaving Water F/C _____
Cond Design	_____ GPM L/S	_____ PSID	_____ kPad	Ent. Water F/C _____	Leaving Water F/C _____
Cond Actual	_____ GPM L/S	_____ PSID	_____ kPad	Ent. Water F/C _____	Leaving Water F/C _____
Owner Witness Signature: _____					

# Unit Shutdown

## Normal Shutdown to Stopped

The Normal Shutdown diagram shows the Transition from Running through a Normal (friendly) Shutdown. The

Dashed lines on the top attempt to show the final mode if you enter the stop via various inputs.

Figure 81. RTWD Normal shutdown

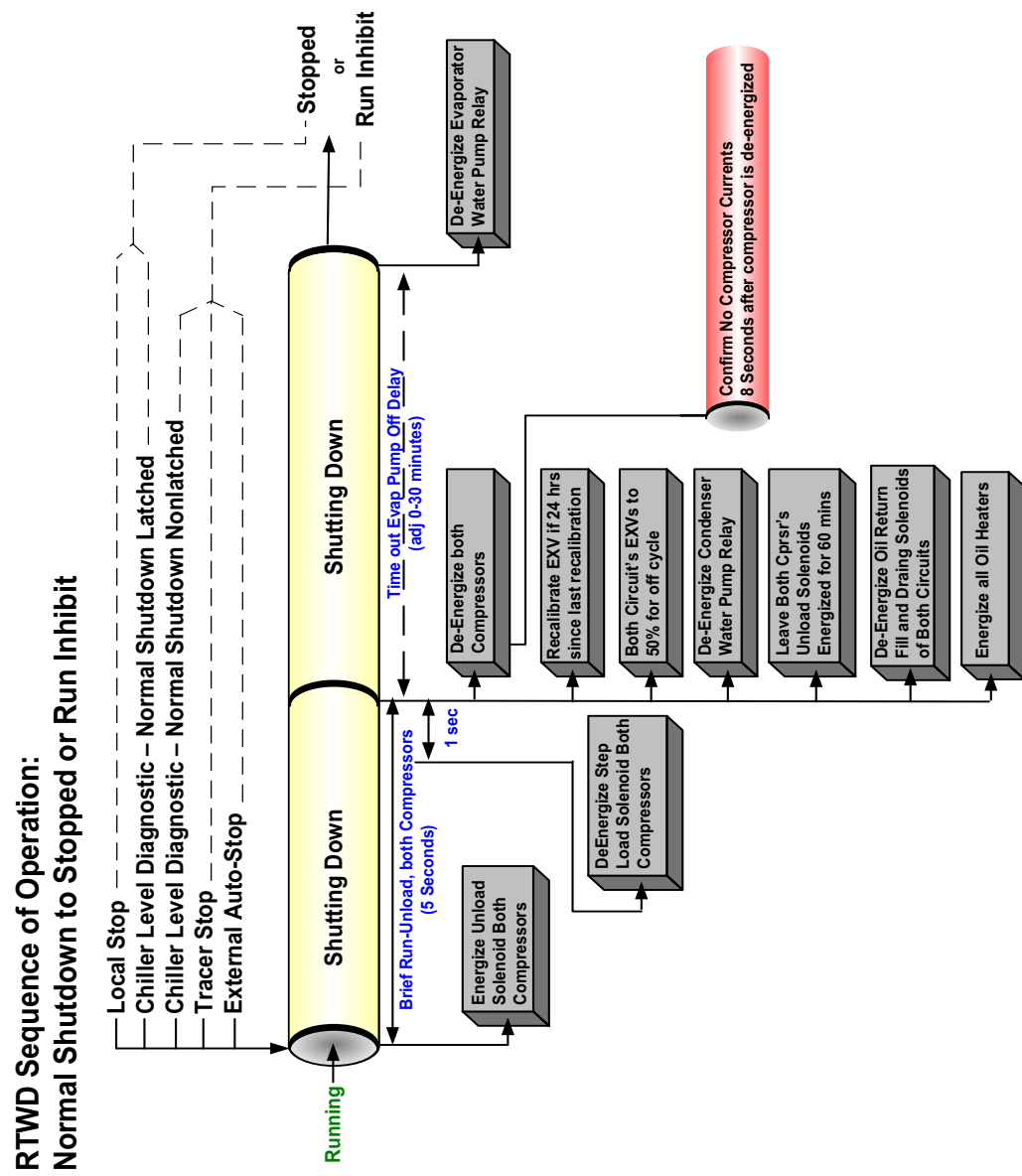
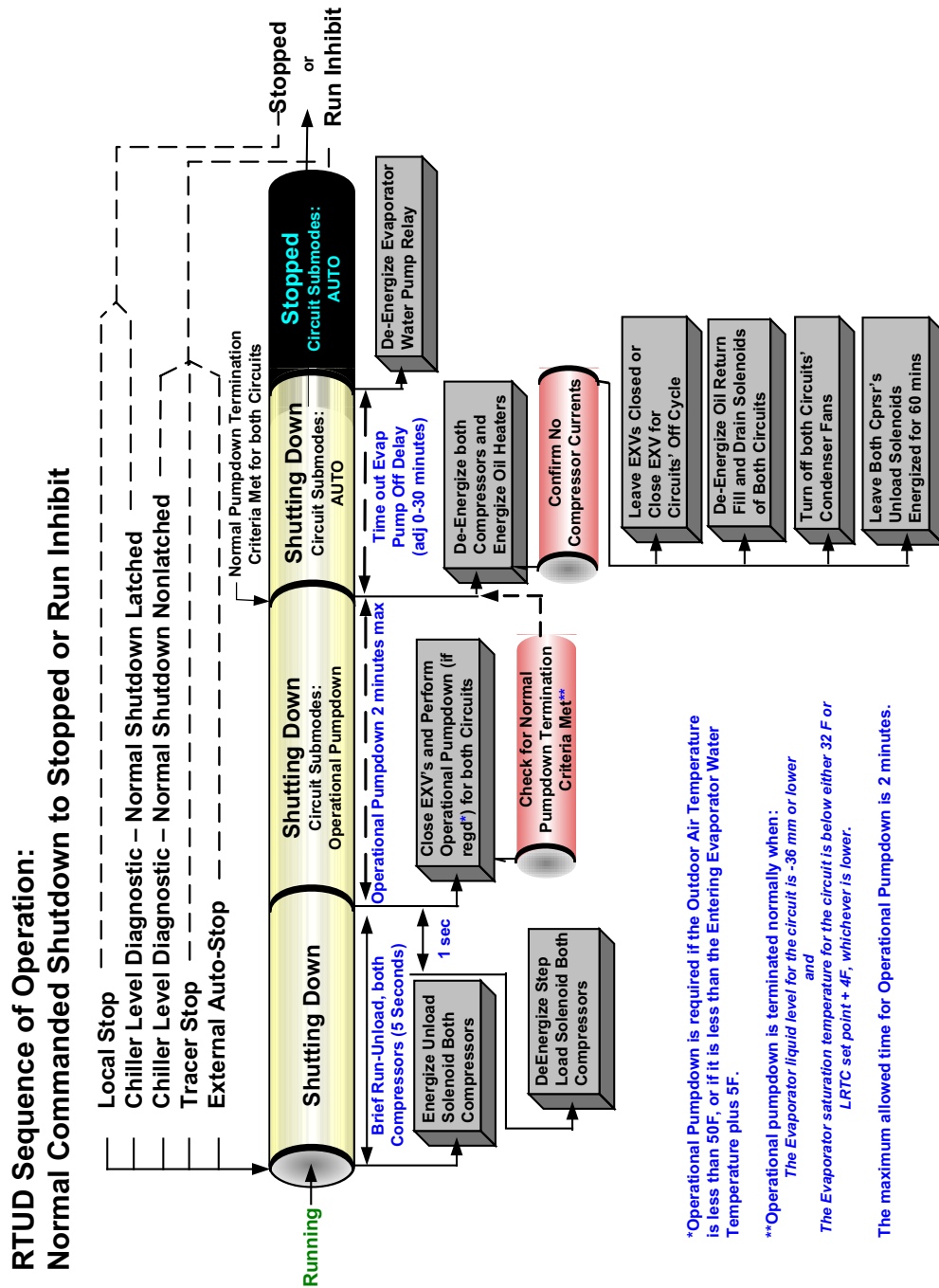

Figure 82. RTUD Normal shutdown



## Seasonal Unit Shutdown

1. Perform normal unit stop sequence using <Stop> key.  
Note: Do not open starter disconnect switch. It must remain closed to provide power from control power transformer to the oil heaters.
2. Verify chilled water and condenser water pumps are off. If desired, open disconnect switches to pumps.
3. Drain condenser piping and cooling tower, if desired.
4. Remove drain and vent plugs from condenser headers to drain the condenser.
5. Verify that the oil heaters are working.
6. Once unit is secured, perform maintenance identified in the following sections.

# Service and Maintenance

## Overview

This section describes preventative maintenance procedures and intervals for the RTWD unit. Use a periodic maintenance program to ensure optimal performance and efficiency of the Series R units.

An important aspect of the chiller maintenance program is the regular completion of the "Series R Operating Log"; an example of this log is provided in this manual. When filled out properly the completed logs can be reviewed to identify any developing trends in the chiller's operating conditions.

For example, if the machine operator notices a gradual increase in condensing pressure during a month's time, he can systematically check for and then correct, the possible cause(s) of this condition (e.g., fouled condenser tubes, non-condensables in the system).

## Maintenance

### ⚠ WARNING

#### Hazardous Voltage!

**Disconnect all electric power, including remote disconnects before servicing. Follow proper lockout/tagout procedures to ensure the power can not be inadvertently energized. Failure to disconnect power before servicing could result in death or serious injury.**

### ⚠ WARNING

#### Live Electrical Components!

**During installation, testing, servicing and troubleshooting of this product, it may be necessary to work with live electrical components. Have a qualified licensed electrician or other individual who has been properly trained in handling live electrical components perform these tasks. Failure to follow all electrical safety precautions when exposed to live electrical components could result in death or serious injury.**

## Weekly Maintenance and Checks

After the unit has operated for approximately 30 minutes and the system has stabilized, check the operating conditions and complete the procedures below:

- Log the chiller.
- Check evaporator and condenser pressures with gauges and compare to the reading on the CH530. Pressure readings should fall within the specified ranges listed under Operating Conditions.

**Note:** For RTWD units, optimum condenser pressure is dependent on condenser water temperature, and should equal the saturation pressure of the refrigerant at a temperature 2 to 5°F above that of leaving condenser water at full load.

## Monthly Maintenance and Checks

- Review operating log.
- Clean all water strainers in both the chilled and condensing water piping systems.
- Measure the oil filter pressure drop. Replace oil filter if required. Refer to "Service Procedures".
- Measure and log the subcooling and superheat.
- If operating conditions indicate a refrigerant shortage, leak check the unit and confirm using soap bubbles.
- Repair all leaks.
- Trim refrigerant charge until the unit operates in the conditions listed in the note below.

**Note:** AHRI conditions are: condenser water: 85°F and 3 GPM per ton and evaporator water: 54-44°F.

- Clean condenser coils.

**Table 124. RTWD Operating Conditions at Full Load**

Description	Condition
Evaporator pressure	30-45 psig
Condensing pressure	75-125 psig
Discharge superheat	10-15 F
Subcooling	5-10 F

**Note:** All conditions stated above are based on the unit running fully loaded, running at AHRI conditions.

- If full load conditions can not be met. Refer to note below to trim the refrigerant charge

**Note:** Conditions at minimum must be: entering condenser water: 85°F and entering evaporator water: 55°F

**Table 125. RTWD Operating Conditions at Minimum Load**

Description	Condition
Evaporator approach	*less than 7°F (non-glycol applications)
Condensing approach	*less than 7°F
Subcooling	2-3°F
EXV percent open	10-20% open

\*  $\cong$  1.0°F for new unit.

**Note:** RTUD operating conditions are the physical configuration of the installation.

## Annual Maintenance

Shut down the chiller once each year to check the following:

**⚠ WARNING****Hazardous Voltage!**

**Disconnect all electric power, including remote disconnects before servicing. Follow proper lockout/tagout procedures to ensure the power can not be inadvertently energized. Failure to disconnect power before servicing could result in death or serious injury.**

- Perform all weekly and monthly maintenance procedures.
- Check the refrigerant charge and oil level. Refer to "Maintenance Procedures". Routine oil changing is not necessary on a hermetic system.
- Have a qualified laboratory perform an oil analysis to determine system moisture content and acid level.

Note: Due to the hygroscopic properties of the POE oil, all oil must be stored in metal containers. The oil will absorb water if stored in a plastic container.

- Check the pressure drop across the oil filter. Refer to "Maintenance Procedures".
- Contact a qualified service organization to leak check the chiller, to inspect safety controls, and inspect electrical components for deficiencies.
- Inspect all piping components for leakage and/or damage. Clean out any inline strainers.
- Clean and repaint any areas that show signs of corrosion.
- Test vent piping of all relief valves for presence of refrigerant to detect improperly sealed relief valves. Replace any leaking relief valve.
- Inspect the condenser tubes for fouling; clean if necessary. Refer to "Maintenance Procedures".
- Check to make sure that the crank case heater is working.

**Scheduling Other Maintenance**

- Use a nondestructive tube test to inspect the condenser and evaporator tubes at 3-year intervals.

Note: It may be desirable to perform tube tests on these components at more frequent intervals, depending upon chiller application. This is especially true of critical process equipment.

- Depending on chiller duty, contact a qualified service organization to determine when to conduct a complete examination of the unit to determine the condition of the compressor and internal components.

**Operating Log**

A sample of several operating logs and checklists have been included.

## Service and Maintenance

Chiller Log			
Main Tab	Run Time		
	15 min	30 min	1 hr
Chiller Mode			
Evap Ent/Lvg Water Temp			
Cond Ent/Lvg Water Temp			
Active Chilled Water Setpoint (F)			
Average Line Current (%RLA)			
Active Current Limit Setpoint (%RLA)			
Software Type			
Software Version			
Reports Tab			
Evaporator			
Evap Entering Water Temperature (F)			
Evap Leaving Water Temperature (F)			
Evap Sat Rfgt Temp (F)			
Evap Rfgt Pressure (psia)			
Evap Approach Temp (F)			
Evap Water Flow Switch Status			
Expansion Valve Position (%)			
Expansion Valve Position Steps			
Evap Rfgt Liquid Level (in)			
Condenser			
Cond Entering Water Temperature (F)			
Cond Leaving Water Temperature (F)			
Cond Sat Rfgt Temp (F)			
Cond Rfgt Pressure (psia)			
Cond Approach Temp (F)			
Cond Water Flow Switch Status			
Cond Head Pressure Ctrl Command (%)			
Compressor 1			
Compressor Starts			
Compressor Run Time			
System Rfgt Diff Pressure (psid)			
Oil Pressure (psia)			
Compressor Rfgt Discharge Temp (F)			
Discharge Superheat (F)			
% RLA L1 L2 L3 (%)			
Amps L1 L2 L3 (Amps)			
Volts AB BC CA			
Compressor 2			
Compressor Starts			
Compressor Run Time			
System Rfgt Diff Pressure (psid)			
Oil Pressure (psia)			
Compressor Rfgt Discharge Temp (F)			
Discharge Superheat (F)			
% RLA L1 L2 L3 (%)			
Amps L1 L2 L3 (Amps)			
Volts AB BC CA			

<b>Settings</b>	
<b>Settings Tab</b>	
<b>Chiller</b>	
Front Panel Chilled Water Setpt (F)	
Front Panel Current Limit Setpt (RLA)	
Differential to Start (F)	
Differential to Stop (F)	
Setpoint Source	
<b>Feature Settings</b>	
Chilled Water Reset	
Return Reset Ratio	
Return Start Reset	
Return Maximum Reset	
Outdoor Reset Ratio	
Outdoor Start Reset	
Outdoor Maximum Reset	
<b>Mode Overrides</b>	
Evap Water Pump	
Cond Water Pump	
Expansion Valve Control	
Slide Valve Control	
Service Pumpdown	
<b>Display Settings</b>	
Date Format	
Date	
Time Format	
Time of Day	
Keypad/Display Lockout	
Display Units	
Pressure Units	
Language Selection	



## Service Procedures

### Cleaning the Condense (RTWD Only)

#### NOTICE:

##### Proper Water Treatment!

The use of untreated or improperly treated water could result in scaling, erosion, corrosion, algae or slime. It is recommended that the services of a qualified water treatment specialist be engaged to determine what water treatment, if any, is required. Trane assumes no responsibility for equipment failures which result from untreated or improperly treated water, or saline or brackish water.

Condenser tube fouling is suspect when the “approach” temperature (i.e., the difference between the refrigerant condensing temperature and the leaving condenser water temperature) is higher than predicted.

Standard water applications will operate with less than a 10°F approach. If the approach exceeds 10°F cleaning the condenser tubes is recommended.

Note: Glycol in the water system may as much as double the standard approach.

If the annual condenser tube inspection indicates that the tubes are fouled, 2 cleaning methods can be used to rid the tubes of contaminants. The methods are:

#### Mechanical Cleaning Procedure

Mechanical tube cleaning method is used to remove sludge and loose material from smooth-bore condenser tubes.

#### WARNING

##### Heavy Objects!

Each of the individual cables (chains or slings) used to lift the waterbox must be capable of supporting the entire weight of the waterbox. The cables (chains or slings) must be rated for overhead lifting applications with an acceptable working load limit. Failure to properly lift waterbox could result in death or serious injury.

#### WARNING

##### Heavy Objects!

The proper use and ratings for eyebolts can be found in ANSI/ASME standard B18.15. Maximum load rating for eyebolts are based on a straight vertical lift in a gradually increasing manner. Angular lifts will significantly lower maximum loads and should be avoided whenever possible. Loads should always be applied to eyebolts in the plane of the eye, not at some angle to this plane. Failure to properly lift waterbox could result in death or serious injury.

Review mechanical room limitations and determine the safest method or methods of rigging and lifting the waterboxes.

#### 1. Waterbox Removal Procedure - Method 1

This selection applies to the units and condenser side waterboxes shown in [Table 126](#).

**Table 126. Waterbox Removal Procedure - Method 1**

Size	Hz	Effic	Condenser Waterbox
80, 90, 100, 110, 120, 130, 140	60	STD	Supply, Return
80, 90, 100, 110, 120, 130	60	HIGH	Supply, Return
70, 80, 90, 100, 110, 120, 130, 140, 150	50	STD	Supply, Return
60, 70, 80, 90, 100, 110, 120	50	HIGH	Supply, Return
150, 160, 180, 200, 220, 250	60	HIGH	Supply
150, 160, 180, 200	60	PREM	Supply
130, 140, 160, 180, 200, 220, 250	50	HIGH	Supply
160, 180, 200	50	PREM	Supply

2. Select the proper lift connection device from [Table 131](#). The rated lifting capacity of the selected lift connection device must meet or exceed the published weight of the waterbox. Reference [Table 130, p. 188](#) for waterbox weights.
3. Ensure the lift connection device has the correct connection for the waterbox. Example: thread type (course/fine, English/metric). Bolt diameter (English/metric).
4. Properly connect the lift connection device to the waterbox. See [Figure 83, p. 186](#). Ensure lift connection device is securely fastened.

**Figure 83. Water box lifting**

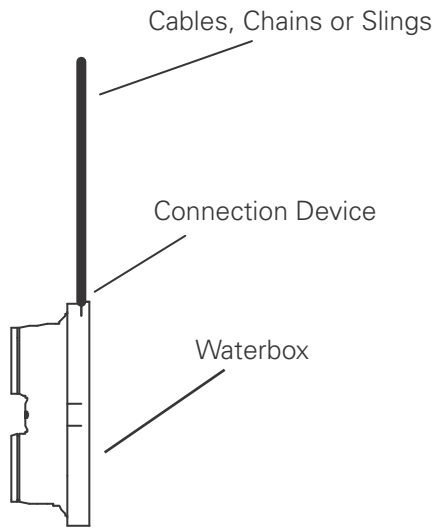

5. Install hoist ring on to the lifting connection on the waterbox. Torque to 28 ft-lbs (37 Nm).
6. Disconnect water pipes, if connected.
7. Remove waterbox bolts
8. Lift the waterbox away from the shell.

**Waterbox Removal Procedure – Method 2**

This selection applies to the units and condenser side waterboxes shown in [Table 127](#)

**Table 127. Waterbox Removal Procedure - Method 2**

Size	Hz	Effic	Condenser Waterbox
150, 160, 180, 200, 220, 250	60	HIGH	Return
150, 160, 180, 200	60	PREM	Return
130, 140, 160, 180, 200, 220, 250	50	HIGH	Return
160, 180, 200	50	PREM	Return

**CAUTION**

**Risk of Injury!**

To prevent injury, do not place hands or fingers between waterbox and condenser tubesheet.

9. Select the proper lift connection device from [Table 131, p. 188](#). The rated lifting capacity of the selected lift connection device must meet or exceed the published weight of the waterbox. Reference [Table 130, p. 188](#) for waterbox weights.
10. Ensure the lift connection device has the correct connection for the waterbox. Example: thread type

(course/fine, English/metric). Bolt diameter (English/metric).

11. Disconnect water pipes, if connected.
12. Remove the two bolts with drill point mark. Install the long bolts into these two holes. The long bolts are located on the two thread holes just above the waterbox, as shown in [Figure 84](#).

**Figure 84. Waterbox removal - remove bolts**

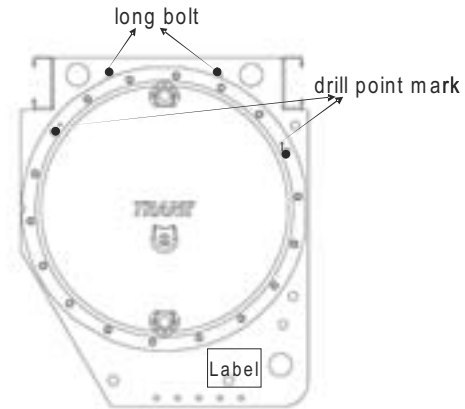

13. Remove the remaining bolts. Slide the waterbox out about 30 mm through two long bolts. Install the Safety Hoist ring (D ring) connection device into the tap drill hole located on waterbox right side (face to waterbox convex). See [Figure 85](#).

**Figure 85. Waterbox removal - slide out, install safety hoist ring**

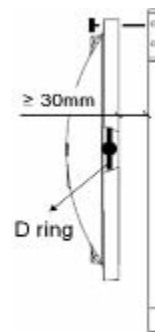

14. Remove the left long bolt while supporting waterbox from outside of waterbox. Swing the waterbox outboard. Put lifting chain on Safety Hoist ring and remove the remaining long bolt. See [Figure 86, p. 187](#).

## Service and Maintenance

**Figure 86. Waterbox removal - swing out, install lifting chain**

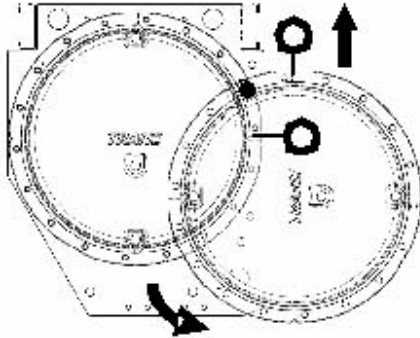

15. Lift the waterbox away from the shell.

### ⚠ WARNING

#### Overhead Hazard!

Never stand below or in close proximity to heavy objects while they are suspended from, or being lifted by, a lifting device. Failure to follow these instructions could result in death or serious injuries.

### All RTWD Units

16. Store waterbox in a safe and secure location and position.

**Table 129. RTWD/RTUD Evaporator waterbox weights**

Model	Size	Hz	Effic	Waterbox	Standard Grooved Pipe Waterbox	
					Weight - kg (lbs)	Lifting Connection
RTWD	80, 90, 100, 110, 120, 130, 140	60	STD	Supply, Return	20.4 (45)	M12x1.75
RTWD	80, 90, 100, 110, 120, 130	60	HIGH	Supply, Return		
RTWD	70, 80, 90, 100, 110, 120, 130, 140, 150	50	STD	Supply, Return		
RTWD	60, 70, 80, 90, 100, 110, 120	50	HIGH	Supply, Return		
RTWD	150, 160, 180, 200, 220, 250	60	HIGH	Supply, Return		
RTWD	150, 160, 180, 200	60	PREM	Supply, Return		
RTWD	130, 140, 160, 180, 200, 220, 250	50	HIGH	Supply, Return		
RTWD	160, 180, 200	50	PREM	Supply, Return		
RTUD	80, 90, 100, 110, 120, 130	60	HIGH	Supply, Return		
RTWD	150, 160, 180, 200, 220, 250	60	HIGH	Supply	33.6 (74)	M12x1.75
RTWD	150, 160, 180, 200	60	PREM	Supply		
RTWD	130, 140, 160, 180, 200, 220, 250	50	HIGH	Supply		
RTWD	160, 180, 200	50	PREM	Supply		
RTUD	150, 160, 180, 200, 220, 250	60	HIGH	Supply		

**Important:** Do not leave waterbox suspended from lifting device.

17. Work a round nylon or brass bristled brush (attached to a rod) in and out of each of the condenser water tubes to loosen the sludge.

18. Thoroughly flush the condenser water tubes with clean water.

**Note:** (To clean internally enhanced tubes, use a bi-directional brush or consult a qualified service organization for recommendations.)

### Reassembly

Once service is complete, the waterbox should be reinstalled on the shell following all previous procedures in reverse.

- Use new o-rings or gaskets on all joints after thoroughly cleaning each joint.
- Torque waterbox bolts.

**Note:** Torque bolts in a star pattern. Refer to [Table 128](#) for torque values.

**Table 128. Torque Values**

Evaporator	Condenser (RTWD only)
65 ft-lbs (88 Nm)	65 ft-lbs (88 Nm)

### Waterbox Weights



## Service and Maintenance

**Table 129. RTWD/RTUD Evaporator waterbox weights (continued)**

Model	Size	Hz	Effic	Waterbox	Standard Grooved Pipe Waterbox	
					Weight - kg (lbs)	Lifting Connection
RTWD	150, 160, 180, 200, 220, 250	60	HIGH	Return	29.9 (66)	M12x1.75
RTWD	150, 160, 180, 200	60	PREM	Return		
RTWD	130, 140, 160, 180, 200, 220, 250	50	HIGH	Return		
RTWD	160, 180, 200	50	PREM	Return		
RTUD	150, 160, 180, 200, 220, 250	60	HIGH	Return		

**Table 130. RTWD Condenser waterbox weights**

Model	Size	Hz	Effic	Waterbox	Standard Grooved Pipe Waterbox	
					Weight - kg (lbs)	Lifting Connection
RTWD	80, 90, 100, 110, 120, 130, 140	60	STD	Supply, Return	20.4 (45)	M12x1.75
RTWD	80, 90, 100, 110, 120, 130	60	HIGH	Supply, Return		
RTWD	70, 80, 90, 100, 110, 120, 130, 140, 150	50	STD	Supply, Return		
RTWD	60, 70, 80, 90, 100, 110, 120	50	HIGH	Supply, Return		
RTWD	150, 160, 180, 200, 220, 250	60	HIGH	Supply, Return		
RTWD	150, 160, 180, 200	60	PREM	Supply, Return		
RTWD	130, 140, 160, 180, 200, 220, 250	50	HIGH	Supply, Return		
RTWD	160, 180, 200	50	PREM	Supply, Return		
RTUD	80, 90, 100, 110, 120, 130	60	HIGH	Supply, Return		
RTWD	150, 160, 180, 200, 220, 250	60	HIGH	Supply	38.6 (85)	M12x1.75
RTWD	150, 160, 180, 200	60	PREM	Supply		
RTWD	130, 140, 160, 180, 200, 220, 250	50	HIGH	Supply		
RTWD	160, 180, 200	50	PREM	Supply		
RTWD	150, 160, 180, 200, 220, 250	60	HIGH	Return	29.9 (66)	M12x1.75
RTWD	150, 160, 180, 200	60	PREM	Return		
RTWD	130, 140, 160, 180, 200, 220, 250	50	HIGH	Return		
RTWD	160, 180, 200	50	PREM	Return		

### Parts Ordering Information

**Table 131. Connection devices**

Unit	Product	Part Number
RTWD/RTUD - All units	Safety Hoist Ring M12x1.75	RNG01886

Obtain the required parts from your local Trane Parts Center.

### Chemical Cleaning Procedure

- Scale deposits are best removed by chemical means. Consult a qualified water treatment specialist (i.e., one that knows the local water supply chemical/mineral content) for a recommended cleaning solution suitable for the job. (A standard condenser water circuit is composed solely of copper, cast iron and steel.) Improper chemical cleaning can damage tube walls.

All of the materials used in the external circulation system, the quantity of the solution, the duration of the cleaning period, and any required safety precautions should be approved by the company furnishing the materials or performing the cleaning.

Note: Chemical tube cleaning should always be followed by mechanical tube cleaning.

### RTUD Air Cooled Condenser Applications - High Condenser Pressure Limit and High Pressure Cutout Diagnostics

If a circuit experiences significant time in the High Condenser Pressure Limit mode, or if it experiences High Pressure Cutout trip diagnostics, the air cooled condenser may be the root cause and should be inspected.

The condenser coils should be checked for air flow restrictions and cleanliness, as well as the possibility of recirculated air, in which the air entering the coil is

## Service and Maintenance

significantly higher temperature than the ambient outdoor air temperature (5 °F or more).

All of the fans should also be validated to be operational with the proper fan blade rotation direction. Dirty, or fouled coils, or otherwise limited or restricted air flow through the coils, can significantly degrade the efficiency of the chiller as well as result in unnecessary limits and nuisance trips. Refer to the condenser manufacturers' maintenance and cleaning procedures.

### Cleaning the Evaporator

Since the evaporator is typically part of a closed circuit, it does not accumulate appreciable amounts of scale or sludge. However, if cleaning is deemed necessary, use the same cleaning methods described for the condenser tubes.

### Compressor Oil

#### **NOTICE:**

#### **Equipment Damage!**

**To prevent oil sump heater burnout, open the unit main power disconnect switch before removing oil from the compressor.**

Trane Polyolester Oil is the approved oil for the RTWD/RTUD units. Polyolester oil is extremely hygroscopic meaning it readily attracts moisture. The oil can not be stored in plastic containers due to the hygroscopic properties. As with mineral oil, if water is in the system it will react with the oil to form acids. Use Table 132 to determine the acceptability of the oil.

**Table 132. POE Oil Properties**

Description	Acceptable Levels
Moisture content	less than 300 ppm
Acid Level	less than 0.5 TAN (mg KOH/g)
<b>Note:</b> Mineral oil used in the RTHA and RTHB units has different acceptable levels (< 50 ppm of moisture and < 0.05 mg KOH/g)	

Note: Use an oil transfer pump to change the oil regardless of chiller pressure.

### Oil Sump Level Check

Running the chiller at minimum load is the best for the quickest return of oil to the separator and sump. The machine still needs to sit for approximately 30 minutes before the level is taken. At minimum load, the discharge superheat should be highest. The more heat in the oil as it lays in the sump, the more refrigerant will boil off in the sump and leave more concentrated oil.

The oil level in the oil sump can be measured to give an indication of the system oil charge. Follow the procedures below to measure the level.

1. Run the unit fully unloaded for approximately 20 minutes.
2. Cycle the compressor off line.

#### **NOTICE:**

#### **Equipment Damage!**

**Never operate the compressor with the sight glass service valves opened. Severe oil loss will occur. Close the valves after checking the oil level. The sump is above the condenser and it is possible to drain the oil.**

**Figure 87. Determining oil level in the sump**

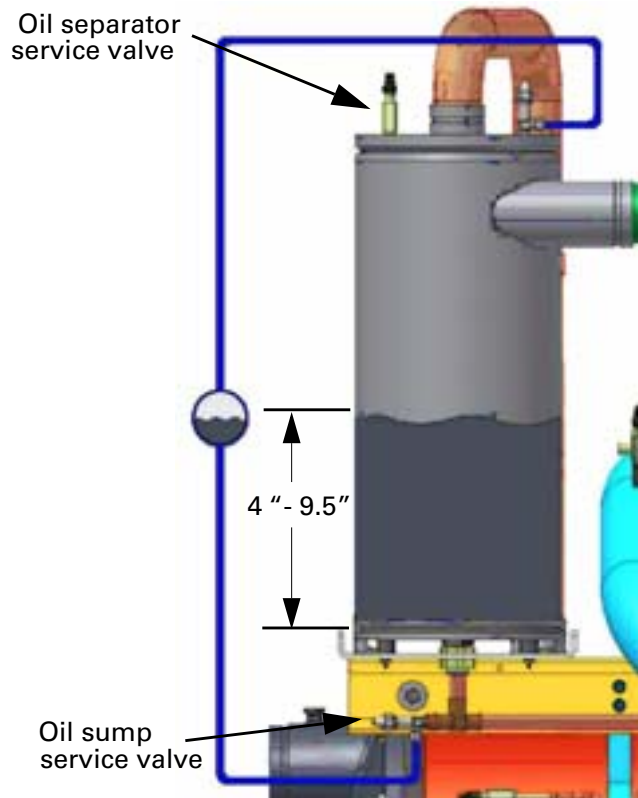

3. Attach a 3/8" or 1/2" hose with a sightglass in the middle to the oil sump service valve (1/4" flare) and the oil separator service valve (1/4" flare).

Note: Using high pressure rated clear hose with appropriate fittings can help speed up the process.

4. After the unit is off line for 30 minutes, move the sightglass along the side of the oil sump.
5. The level should be between 4" and 9.5" from the bottom of the oil sump. If the level appears to be above 9.5", the oil sump is completely full. Most likely more oil resides in the rest of the system and some oil needs to be removed until the level falls between 4" and 9.5" in the oil sump.

Note: Nominal height of oil is 8 inches.

## Service and Maintenance

- If the level is below 4" there is not enough oil in the sump. This can occur from not enough oil in the system or more likely, oil migration to the evaporator. Oil migration can occur from a low refrigerant charge, gas pump malfunction, etc.

**Note:** If the oil is logged in the evaporator confirm the operation of the gas pump. If the gas pump is not functioning properly all oil will be logged in the evaporator.

- After the level is determined, close the service valves and remove the hose/sightglass assembly.

### Removing Compressor Oil

The oil in the compressor oil sump is under a constant positive pressure at ambient temperature. To remove oil, open the service valve located on the bottom of the oil sump and drain the oil into a suitable container using the procedure outlined below:

#### **NOTICE:**

#### **Equipment Damage!**

**Due to the hygroscopic properties of the POE oil, all oil must be stored in metal containers. The oil will absorb water if stored in a plastic container.**

Oil should not be removed until the refrigerant is isolated or removed.

- Connect a line to the oil sump drain valve.
- Open the valve and allow the desired amount of oil to flow into the container and close the charging valve.
- Measure the exact amount of oil removed from the unit.

### Oil Charging Procedure

It is critical to fill the oil lines feeding the compressor when charging a system with oil. The diagnostic "Loss of oil at the compressor stopped" will be generated if the oil lines are not full on start-up.

**Figure 88. Oil charging port**

**Oil charging port  
(1/4" flare with  
schrader valve)**

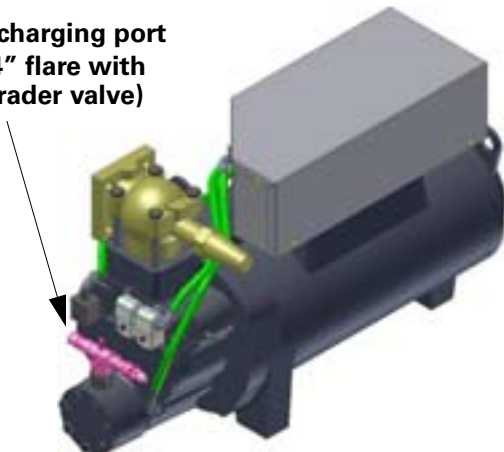

To properly charge the system with oil, follow the steps below:

- Locate the 1/4" schrader valve on the end of the compressor.
- Loosely connect oil pump to schrader valve called out in step 1.
- Operate oil charging pump until oil appears at the charging valve connection; then tighten the connection.

**Note:** To keep air from entering the oil, the charging valve connection must be air-tight.

- Open the service valve and pump in the required amount of oil.

**Note:** Adding oil at the oil charging port ensures that the oil filter cavity and the oil lines back to the oil separator are filled with oil. An internal oil valve prevents oil from entering the compressor rotors.

### Replacing the Oil Filter

The filter element should be changed if the oil flow is sufficiently obstructed. Two things can happen: first, the chiller may shut down on a "Low Oil Flow" diagnostic, or secondly, the compressor may shut down on a "Loss of Oil at Compressor (Running)" diagnostic. If either of these diagnostics occurs, it is possible the oil filter needs replacement. The oil filter is not usually the cause of a Loss of oil at Compressor diagnostic.

Specifically, the filter must be changed if the pressure drop between the two service valves in the lubrication circuit exceeds the maximum level as given in [Figure 89, p. 191](#). This chart shows the relationship between the pressure drop measured in the lubrication circuit as compared with operating pressure differential of the chiller (as measured by pressures in the condenser and evaporator).

Normal pressure drops between the service valves of the lubrication circuit are shown by the lower curve. The upper curve represents the maximum allowable pressure drop and indicates when the oil filter must be changed. Pressure drops that lie between the lower and upper curves are considered acceptable.

For a chiller equipped with an oil cooler, add 5 psid to the values shown in [Figure 89](#). For example, if the system pressure differential was 80 psid, then the clean filter pressure drop would be approximately 15 psid (up from 10 psid). For a chiller with an oil cooler and operating with a dirty oil filter, the maximum allowable pressure drop would be 28 psid (up from 23 psid).

Under normal operating conditions the element should be replaced after the first year of operation and then as needed thereafter.

## Service and Maintenance

Figure 89. Recommended oil filter replacement

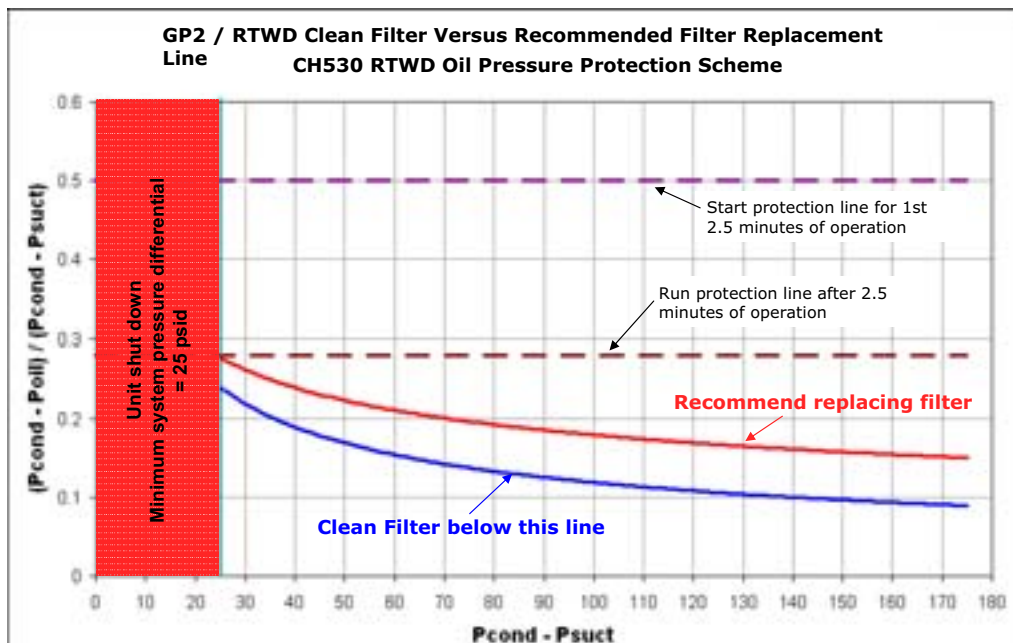

## Refrigerant Charge

If a low refrigerant charge is suspected, first determine the cause of lost refrigerant. Once the problem is repaired follow the procedures below for evacuating and charging the unit.

### Evacuation and Dehydration

5. Disconnect ALL power before/during evacuation.
6. Connect the vacuum pump to the 5/8" flare connection on the bottom of the evaporator and/or condenser.
7. To remove all of the moisture from the system and to insure a leak free unit, pull the system down below 500 microns.
8. After the unit is evacuated, perform a standing rise test for at least an hour. The pressure should not rise more than 150 microns. If the pressures rises more than 150 microns, either a leak is present or moisture is still in the system.

Note: If oil is in the system, this test is more difficult. The oil is aromatic and will give off vapors that will raise the pressure of the system.

### Refrigerant Charging

On RTWD Units, once the system is deemed leak and moisture free, use the 5/8" flare connections at the bottom of the evaporator and condenser to add refrigerant charge.

For RTUD Units, once the system is deemed leak and moisture free, use the service valve on the liquid line to add refrigerant charge.

### NOTICE:

#### Equipment Damage!

Add field refrigerant charge only through the service valve on the liquid line, not the service valves on the evaporator, and insure that water is flowing through the evaporator during the charging process. Failure to do the above could result in equipment damage.

See "General Data," p. 9 and Unit nameplate for refrigerant charge information.

#### Refrigerant and Oil Charge Management

Proper oil and refrigerant charge is essential for proper unit operation, unit performance, and environmental protection. Only trained and licensed service personnel should service the chiller.

#### Some symptoms of a refrigerant under-charged unit:

- Low subcooling
- Higher than normal discharge superheat
- Bubbles in EXV sight glass
- Low liquid level diagnostic
- Larger than normal evaporator approach temperatures (leaving water temperature - saturated evaporator temperature)
- Low evaporator refrigerant temperature limit
- Low refrigerant temperature cutout diagnostic



## Service and Maintenance

---

- Fully open expansion valve
- Possible whistling sound coming from liquid line (due to high vapor velocity)
- High condenser + subcooler pressure drop

### ***Some symptoms of a refrigerant over-charged unit:***

- High subcooling
- Evaporator liquid level higher than centerline after shut down
- Larger than normal condenser approach temperatures (entering condenser saturated temperature – leaving condenser water temperature)
- Condenser pressure limit
- High pressure cutout diagnostic
- Higher than normal compressor power
- Very low discharge superheat at startup
- Compressor rattle or grinding sound at startup

### ***Some symptoms of an oil over-charged unit:***

- Larger than normal evaporator approach temperatures (leaving water temperature - saturated evaporator temperature)
- Low evaporator refrigerant temperature limit
- Erratic liquid level control
- Low unit capacity
- Low discharge superheat (especially at high loads)
- Low liquid level diagnostics
- High oil sump level after normal shut down

### ***Some symptoms of an oil under-charged unit:***

- Compressor rattle or grinding sound
- Lower than normal pressure drop through oil system
- Seized or welded compressors
- Low oil sump level after normal shut down
- Lower than normal oil concentrations in evaporator

## **Refrigerant Filter Replacement Procedure**

A dirty filter is indicated by a temperature gradient across the filter, corresponding to a pressure drop. If the temperature downstream of the filter is 4°F (-15.5°C) lower than the upstream temperature, the filter should be replaced. A temperature drop can also indicate that the unit is undercharged. Ensure proper subcooling before taking temperature readings.

1. With the unit off, verify that the EXV is closed. Close liquid line isolation valve.
2. Attach hose to service port on liquid line filter flange.
3. Evacuate refrigerant from liquid line and store.
4. Remove hose.

5. Depress schrader valve to equalize pressure in liquid line with atmospheric pressure.
6. Remove bolts that retain filter flange.
7. Remove old filter element.
8. Inspect replacement filter element and lubricate o-ring with Trane OIL00048.

Note: Do not use mineral oil. It will contaminate the system.

9. Install new filter element in filter housing.
10. Inspect flange gasket and replace if damaged.
11. Install flange and torque bolts to 14-16 lb-ft (19-22 n-m).
12. Attach vacuum hose and evacuate liquid line.
13. Remove vacuum hose from liquid line and attach charging hose.
14. Replace stored charge in liquid line.
15. Remove charging hose.
16. Open liquid line isolation valve.

## **Freeze Protection**

For unit operation in a low temperature environment, adequate protection measures must be taken against freezing.



# Diagnostics

**Diagnostic Name and Source:** Name of Diagnostic and its source. Note that this is the exact text used in the User Interface and/or Service Tool displays.

**Affects Target:** Defines the “target” or what is affected by the diagnostic. Usually either the entire Chiller, or a particular Circuit or Compressor is affected by the diagnostic (the same one as the source), but in special cases functions are modified or disabled by the diagnostic. None implies that there is no direct affect to the chiller, sub components or functional operation.

**Severity:** Defines the severity of the above effect. Immediate means immediate shutdown of the affected portion, Normal means normal or friendly shutdown of the affected portion, Special Action means a special action or mode of operation (limp along) is invoked, but without shutdown, and Info means an Informational Note or Warning is generated.

**Persistence:** Defines whether or not the diagnostic and its effects are to be manually reset (Latched), or can be either manually or automatically reset when and if the condition returns to normal (Nonlatched).

**Active Modes [Inactive Modes]:** States the modes or periods of operation that the diagnostic is active in and, as necessary, those modes or periods that it is specifically “not active” in as an exception to the active modes. The inactive modes are enclosed in brackets, []. Note that the modes used in this column are internal and not generally announced to any of the formal mode displays.

**Criteria:** Quantitatively defines the criteria used in generating the diagnostic and, if nonlatching, the criteria for auto reset. If more explanation is necessary a hot link to the Functional Specification is used.

**Reset Level:** Defines the lowest level of manual diagnostic reset command which can clear the diagnostic. The manual diagnostic reset levels in order of priority are: Local or Remote. For example, a diagnostic that has a reset level of Remote, can be reset by either a remote diagnostic reset command or by a local diagnostic reset command.

**Help Text:** Provides for a brief description of what kind of problems might cause this diagnostic to occur. Both control system component related problems as well as chiller application related problems are addressed (as can possibly be anticipated). These help messages will be updated with accumulated field experience with the chillers.

## Starter Diagnostics

**Table 133. Starter Diagnostics**

Diagnostic Name and Source	Affects Target	Severity	Persistence	Active Modes [Inactive Modes]	Criteria	Reset Level
Compressor Did Not Accelerate: Transition - Compressor 1A	*Circuit	Info	Latch	Start Mode	The compressor did not come up to speed (fall to <85%RLA) in the allotted time defined by the Maximum Acceleration Timer and a transition was forced (motor put across the line) at that time. This applies to all starter types.	Remote
Compressor Did Not Accelerate: Transition - Compressor 2A	*Circuit	Info	Latch	Start Mode	The compressor did not come up to speed (fall to <85%RLA) in the allotted time defined by the Maximum Acceleration Timer and a transition was forced (motor put across the line) at that time. This applies to all starter types.	Remote
Motor Current Overload - Compressor 1A	Circuit	Immediate	Latch	Cprsr Energized	Compressor current exceeded overload time vs. trip characteristic. Must trip = 140% RLA, Must hold=125%, nominal trip 132.5% in 30 seconds	Local
Motor Current Overload - Compressor 2A	Circuit	Immediate	Latch	Cprsr Energized	Compressor current exceeded overload time vs. trip characteristic. Must trip = 140% RLA, Must hold=125%, nominal trip 132.5% in 30 seconds	Local
Over Voltage	Chiller	Normal	Non Latch	Pre-Start and Any Ckt(s) Energzd	Nom. trip: 60 seconds at greater than 112.5%, ± 2.5%, Auto Reset at 110% or less for 10 cont secs.	Remote
Phase Loss - Compressor 1A	*Circuit	Immediate	Latch	Start Sequence and Run modes	a) No current was sensed on one or two of the current transformer inputs while running or starting (See Nonlatching Power Loss Diagnostic for all three phases lost while running). Must hold = 20% RLA. Must trip = 5% RLA. Time to trip shall be longer than guaranteed reset on Starter Module at a minimum, 3 seconds maximum. Actual design trip point is 10%. The actual design trip time is 2.64 seconds. b) If Phase reversal protection is enabled and current is not sensed on one or more current xformer inputs. Logic will detect and trip in a maximum of 0.3 seconds from compressor start.	Local
Phase Loss - Compressor 2A	*Circuit	Immediate	Latch	Start Sequence and Run modes	a) No current was sensed on one or two of the current transformer inputs while running or starting (See Nonlatching Power Loss Diagnostic for all three phases lost while running). Must hold = 20% RLA. Must trip = 5% RLA. Time to trip shall be longer than guaranteed reset on Starter Module at a minimum, 3 seconds maximum. Actual design trip point is 10%. The actual design trip time is 2.64 seconds. b) If Phase reversal protection is enabled and current is not sensed on one or more current xformer inputs. Logic will detect and trip in a maximum of 0.3 second from compressor start	Local
Phase Reversal - Compressor 1A	*Circuit	Immediate	Latch	Compressor energized to transition command [All Other Times]	A phase reversal was detected on the incoming current. On a compressor startup the phase reversal logic must detect and trip in a maximum of.3 second from compressor start.	Local
Phase Reversal - Compressor 2A	*Circuit	Immediate	Latch	Compressor energized to transition command [All Other Times]	A phase reversal was detected on the incoming current. On a compressor startup the phase reversal logic must detect and trip in a maximum of.3 second from compressor start.	Local

## Diagnostics

**Table 133. Starter Diagnostics**

Diagnostic Name and Source	Affects Target	Severity	Persistence	Active Modes [Inactive Modes]	Criteria	Reset Level
Power Loss - Compressor 1A	*Circuit	Immediate	Non Latch	All compressor running modes [all compressor starting and non-running modes]	The compressor had previously established currents while running and then <u>all three</u> phases of current were lost. Design: Less than 10% RLA, trip in 2.64 seconds. This diagnostic will preclude the Phase Loss Diagnostic and the Transition Complete Input Opened Diagnostic from being called out. To prevent this diagnostic from occurring with the intended disconnect of main power, the minimum time to trip must be greater than the guaranteed reset time of the Starter module. Note: This diagnostic prevents nuisance latching diagnostics due to a momentary power loss – It does not protect motor (compressor from uncontrolled power reapplication. See Momentary Power Loss Diagnostic for this protection. This diagnostic is not active during the start mode before the transition complete input is proven. Thus a random power loss during a start would result in either a "Starter Fault Type 3" or a "Starter Did Not Transition" latching diagnostic.	Remote
Power Loss - Compressor 2A	*Circuit	Immediate	Non Latch	All compressor running modes [all compressor starting and non-running modes]	The compressor had previously established currents while running and then <u>all three</u> phases of current were lost. Design: Less than 10% RLA, trip in 2.64 seconds. This diagnostic will preclude the Phase Loss Diagnostic and the Transition Complete Input Opened Diagnostic from being called out. To prevent this diagnostic from occurring with the intended disconnect of main power, the minimum time to trip must be greater than the guaranteed reset time of the Starter module.	Remote
Severe Current Imbalance - Compressor 1A	Circuit	Immediate	Latch	All Running Modes	A 30% Current Imbalance has been detected on one phase relative to the average of all 3 phases for 90 continuous seconds.	Local
Severe Current Imbalance - Compressor 2A	Circuit	Immediate	Latch	All Running Modes	A 30% Current Imbalance has been detected on one phase relative to the average of all 3 phases for 90 continuous seconds	Local
Starter 1A Dry Run Test	*Circuit	Immediate	Latch	Starter Dry Run Mode	While in the Starter Dry Run Mode either 50% Line Voltage was sensed at the Potential Transformers or 10% RLA Current was sensed at the Current Transformers.	Local
Starter 2A Dry Run Test	*Circuit	Immediate	Latch	Starter Dry Run Mode	While in the Starter Dry Run Mode either 50% Line Voltage was sensed at the Potential Transformers or 10% RLA Current was sensed at the Current Transformers.	Local
Starter Contactor Interrupt Failure - Compressor 1A	Chiller	Special Action	Latch	Starter Contactor not Energized [Starter Contactor Energized]	Detected compressor currents greater than 10% RLA on any or all phases when the compressor was commanded off. Detection time shall be 5 second minimum and 10 seconds maximum. On detection and until the controller is manually reset: generate diagnostic, energize the appropriate alarm relay, continue to energize the Evap Pump Output, continue to command the affected compressor off, fully unload the effected compressor and command a normal stop to all other compressors. For as long as current continues, perform liquid level, oil return, and fan control on the circuit effected.	Local

**Table 133. Starter Diagnostics**

Diagnostic Name and Source	Affects Target	Severity	Persistence	Active Modes [Inactive Modes]	Criteria	Reset Level
Starter Contactor Interrupt Failure - Compressor 2A	Chiller	Special Action	Latch	Starter Contactor not Energized [Starter Contactor Energized]	Detected compressor currents greater than 10% RLA on any or all phases when the compressor was commanded off. Detection time shall be 5 second minimum and 10 seconds maximum. On detection and until the controller is manually reset: generate diagnostic, energize the appropriate alarm relay, continue to energize the Evap Pump Output, continue to command the affected compressor off, fully unload the effected compressor and command a normal stop to all other compressors. For as long as current continues, perform liquid level, oil return, and fan control on the circuit effected.	Local
Starter Did Not Transition - Compressor 1A	*Circuit	Immediate	Latch	On the first check after transition.	The Starter Module did not receive a transition complete signal in the designated time from its command to transition. The must hold time from the Starter Module transition command is 1 second. The Must trip time from the transition command is 6 seconds. Actual design is 2.5 seconds. This diagnostic is active only for Y-Delta, Auto-Transformer, Primary Reactor, and X-Line Starters.	Local
Starter Did Not Transition - Compressor 2A	*Circuit	Immediate	Latch	On the first check after transition.	The Starter Module did not receive a transition complete signal in the designated time from its command to transition. The must hold time from the Starter Module transition command is 1 second. The Must trip time from the transition command is 6 seconds. Actual design is 2.5 seconds. This diagnostic is active only for Y-Delta, Auto-Transformer, Primary Reactor, and X-Line Starters.	Local
Starter Fault Type I - Compressor 1A	*Circuit	Immediate	Latch	Starting - Y Delta Starters Only	This is a specific starter test where 1M(1K1) is closed first and a check is made to ensure that there are no currents detected by the CTs. If currents are detected when only 1M is closed first at start, then one of the other contactors is shorted.	Local
Starter Fault Type I - Compressor 2A	*Circuit	Immediate	Latch	Starting - Y Delta Starters Only	This is a specific starter test where 1M(1K1) is closed first and a check is made to ensure that there are no currents detected by the CTs. If currents are detected when only 1M is closed first at start, then one of the other contactors is shorted.	Local
Starter Fault Type II - Compressor 1A	*Circuit	Immediate	Latch	Starting All types of starters	a. This is a specific starter test where the Shorting Contactor (1K3) is individually energized and a check is made to ensure that there are no currents detected by the CTs. If current is detected when only S is energized at Start, then 1M is shorted. b. This test in a. above applies to all forms of starters (Note: It is understood that many starters do not connect to the Shorting Contactor.).	Local
Starter Fault Type II - Compressor 2A	*Circuit	Immediate	Latch	Starting - All types of starters	a. This is a specific starter test where the Shorting Contactor (1K3) is individually energized and a check is made to ensure that there are no currents detected by the CTs. If current is detected when only S is energized at Start, then 1M is shorted. b. This test in a. above applies to all forms of starters (Note: It is understood that many starters do not connect to the Shorting Contactor.).	Local
Starter Fault Type III - Compressor 1A	*Circuit	Immediate	Latch	Starting [Adaptive Frequency Starter Type]	As part of the normal start sequence to apply power to the compressor, the Shorting Contactor (1K3) and then the Main Contactor (1K1) were energized. 1.6 seconds later there were no currents detected by the CT's for the last 1.2 Seconds on all three phases. The test above applies to all forms of starters except Adaptive Frequency Drives.	Local

## Diagnostics

**Table 133. Starter Diagnostics**

Diagnostic Name and Source	Affects Target	Severity	Persistence	Active Modes [Inactive Modes]	Criteria	Reset Level
Starter Fault Type III – Compressor 2A	*Circuit	Immediate	Latch	Starting [Adaptive Frequency Starter Type]	As part of the normal start sequence to apply power to the compressor, the Shorting Contactor (1K3) and then the Main Contactor (1K1) were energized. 1.6 seconds later there were no currents detected by the CT's for the last 1.2 seconds on all three phases. The test above applies to all forms of starters except Adaptive Frequency Drives.	Local
Transition Complete Input Opened – Compressor 1A	*Circuit	Immediate	Latch	All running modes	The Transition Complete input was found to be opened with the compressor motor running after a successful completion of transition. This is active only for Y-Delta, Auto-Transformer, Primary Reactor, and X-Line Starters. To prevent this diagnostic from occurring as the result of a power loss to the contactors, the minimum time to trip must be greater than the trip time for the power loss diagnostic.	Local
Transition Complete Input Opened – Compressor 2A	*Circuit	Immediate	Latch	All running modes	The Transition Complete input was found to be opened with the compressor motor running after a successful completion of transition. This is active only for Y-Delta, Auto-Transformer, Primary Reactor, and X-Line Starters. To prevent this diagnostic from occurring as the result of a power loss to the contactors, the minimum time to trip must be greater than the trip time for the power loss diagnostic.	Local
Transition Complete Input Shorted – Compressor 1A	*Circuit	Immediate	Latch	Pre-Start	The Transition Complete input was found to be shorted before the compressor was started. This is active for all electromechanical starters.	Local
Transition Complete Input Shorted – Compressor 2A	*Circuit	Immediate	Latch	Pre-Start	The Transition Complete input was found to be shorted before the compressor was started. This is active for all electromechanical starters.	Local
Under Voltage	Chiller	Normal	Non Latch	Pre-Start and Any Ckt(s) Energzd	Nom. trip: 60 seconds at less than 87.5%, ± 2.8% at 200V ± 1.8% at 575V, Auto Reset at 90% or greater.	Remote

## Main Processor Diagnostics

**Table 134. Main Processor Diagnostics**

Diagnostic Name	Affects Target	Severity	Persistence	Active Modes [Inactive Modes]	Criteria	Reset Level
BAS Communication Lost	None	Special Action	Non Latch	All	The BAS was setup as "installed" at the MP and the LonTalk LCIC lost communications with the BAS for 15 contiguous minutes after it had been established. Refer to Section on Setpoint Arbitration to determine how setpoints and operating modes may be effected by the comm loss. The chiller follows the value of the Tracer Default Run Command which can be previously written by Tracer and stored nonvolatily by the MP (either use local or shutdown). Note that this diagnostic is never operational for BacNet Communication interface (BCIC) and only operational with a LonTalk Communication interface (LCIC) if so configured by the BAS or Tracer system.	Remote

## Diagnostics

**Table 134. Main Processor Diagnostics (continued)**

Diagnostic Name	Affects Target	Severity	Persistence	Active Modes [Inactive Modes]	Criteria	Reset Level
BAS Failed to Establish Communication	None	Special Action	Non Latch	At power-up	The BAS was setup as "installed" and the BAS did not communicate with the Lontalk LCIC within 15 minutes after chiller controls power-up. Refer to Section on Setpoint Arbitration to determine how setpoints and operating modes may be effected. Note that this diagnostic is never operational for BacNet Communication interface (BCIC) and only operational with a LonTalk Communication interface (LCIC) if so configured by the BAS or Tracer system.	Remote
Check Clock	Chiller	Info	Latch	All	The real time clock had detected loss of its oscillator at some time in the past. Check/replace battery? This diagnostic can be effectively cleared only by writing a new value to the chiller's time clock using the TechView or DynaView's "set chiller time" functions.	Remote
Condenser Entering Water Temperature Sensor	Chiller	Info and Special Action	Latch	All	RTWD only: Bad Sensor or LLID. If chiller running, and condenser water regulating valve option installed, force valve to 100% flow.	Remote
Condenser Leaving Water Temperature Sensor	Chiller	Info or Special Action	Latch	All	RTWD only: Bad Sensor or LLID. If Chiller is running in the heat mode of operation – normal chiller shutdown, otherwise, informational warning only. Discontinue Min Capacity Limit forced cprsr loading due to Low DP in subsequent startups.	Remote
Condenser Refrigerant Pressure Transducer - Circuit 1	Circuit	Immediate	Latch	All	Bad Sensor or LLID	Remote
Condenser Refrigerant Pressure Transducer - Circuit 2	Circuit	Immediate	Latch	All	Bad Sensor or LLID	Remote
Condenser Water Flow Lost	Chiller	Immediate	Non Latch	Start and All Run Modes	The condenser water flow proof input was open for more than 6 contiguous seconds (or 15 seconds for thermal dispersion type flow switch) after flow had been proven. This diagnostic is automatically cleared once the compressor is stopped by a fixed time out of 7 sec. In Cooling Mode: The Cond Pump shall be commanded off but the Evap pump command will not be effected. – once the diagnostic auto clears, if diff to start is met, the cond pump can be restarted. In Heating Mode: The Cond Pump shall remain on, and the Evap pump shall shut off – once diagnostic auto clears, if diff to start is met, the chiller may restart normally and the evap pump can be restarted.	Remote
Condenser Water Flow Overdue	Chiller	Normal	Non Latch	Estab Cond Water Flow	Condenser water flow was not proven within 20 minutes of the condenser pump relay being energized. The Cond Pump shall be commanded off. Diagnostic is reset with return of flow (although only possible with external control of pump)	Remote
Discharge Temperature Sensor – Compressor 1A	Circuit	Immediate	Latch	All	Bad Sensor or LLID	Remote
Discharge Temperature Sensor – Compressor 2A	Circuit	Immediate	Latch	All	Bad Sensor or LLID	Remote
Emergency Stop	Chiller	Immediate	Latch	All	a. EMERGENCY STOP input is open. An external interlock has tripped. Time to trip from input opening to unit stop shall be 0.1 to 1.0 seconds.	Local

## Diagnostics

**Table 134. Main Processor Diagnostics (continued)**

Diagnostic Name	Affects Target	Severity	Persistence	Active Modes [Inactive Modes]	Criteria	Reset Level
Evaporator Approach Error – Circuit 1	Circuit	Immediate	Latch	Respective circuit running	The Evaporator approach temperature for the respective circuit (ELWT – Evap Sat Temp Ckt x) is negative by 10°F or more, for 1 minute continuously while the circuit/compressor is operating. Either the Evap Leaving Water Temp sensor, or Evap Suction Rfght Pressure Transducer Ckt 1 is in error.	Remote
Evaporator Approach Error – Circuit 2	Circuit	Immediate	Latch	Respective circuit running	The Evaporator approach temperature for the respective circuit (ELWT – Evap Sat Temp Ckt x) is negative by 10°F or more, for 1 minute continuously while the circuit/compressor is operating. Either the Evap Leaving Water Temp sensor, or Evap Suction Rfght Pressure Transducer Ckt 2 is in error.	
Evaporator Entering Water Temperature Sensor	Chiller	Normal	Latch	All	Bad Sensor or LLID Note: Entering Water Temp Sensor is used in EXV pressure control as well as ice making so it must cause a unit shutdown even if ice or CHW reset is not installed.	Remote
Evaporator Leaving Water Temperature Sensor	Chiller	Normal	Latch	All	Bad Sensor or LLID	Remote
Evaporator Liquid Level Sensor – Circuit 1	Circuit	Normal	Latch	All	Bad Sensor or LLID	Remote
Evaporator Liquid Level Sensor – Circuit 2	Circuit	Normal	Latch	All	Bad Sensor or LLID	Remote
Evaporator Water Flow (Entering Water Temp)	None	Info	Non Latch	Any Ckt(s) Energzd [No Ckt(s) Energzd]	The entering evaporator water temp fell below the leaving evaporator water temp by more than 2°F for 100F-sec. For falling film evaporators, this diagnostic cannot reliably indicate loss of flow, but can warn of improper flow direction through the evaporator, misbound water temperature sensors, improper sensor installation, partially failed sensors, or other system problems. Note that either entering or leaving water temp sensor could be at fault.	Remote
Evaporator Water Flow Lost	Chiller	Immediate	Non Latch	[All Stop modes]	a. The Evaporator water flow switch input was open for more than 6 contiguous seconds (or 15 seconds for thermal dispersion type flow switch). b. This diagnostic does not de-energize the evap pump output c. 6 seconds of contiguous flow shall clear this diagnostic.	Remote
Evaporator Water Flow Overdue	Chiller	Normal	Non Latch	Estab. Evap. Water Flow on going from STOP to AUTO or Evap Pump Override.	Evaporator water flow was not proven within 20 minutes of the Evaporator water pump relay being energized in normal "Stop" to "Auto" transition. If the pump is overridden to "On" for certain diagnostics, the delay on diagnostic callout shall be only 255 seconds. The pump command status will not be effected by this diagnostic in either case.	Remote
Excessive Condenser Pressure – Circuit 1	Circuit	Immediate	Latch	All	The condenser pressure transducer of this circuit has detected a pressure in excess of the safe high side pressure as limited by the particular compressor type or the evaporator distributor present on this particular chiller. For Air Cooled Condenser, check for dirty coils or any fouling or restrictions as well as proper operation and rotational direction of all fans.	Remote

## Diagnostics

**Table 134. Main Processor Diagnostics (continued)**

Diagnostic Name	Affects Target	Severity	Persistence	Active Modes [Inactive Modes]	Criteria	Reset Level
Excessive Condenser Pressure – Circuit 2	Circuit	Immediate	Latch	All	The condenser pressure transducer of this circuit has detected a pressure in excess of the safe high side pressure as limited by the particular compressor type or the evaporator distributor present on this particular chiller. For Air Cooled Condenser, check for dirty coils or any fouling or restrictions as well as proper operation and rotational direction of all fans.	Remote
External Chilled (Hot Water Setpoint)	None	Info	Latch	All	a. Function Not "Enabled": no diagnostics. B. "Enabled ": Out-Of-Range Low or Hi or bad LLID, set diagnostic, default CWS to next level of priority (e.g. Front Panel SetPoint). This Info diagnostic will automatically reset if the input returns to the normal range.	Remote
External Current Limit Setpoint	None	Info	Latch	All	a. Not "Enabled": no diagnostics. B. "Enabled ": Out-Of-Range Low or Hi or bad LLID, set diagnostic, default CLS to next level of priority (e.g. Front Panel SetPoint). This Info diagnostic will automatically reset if the input returns to the normal range.	Remote
Fan Fault - Circuit 1	Circuit (fan control)	Special Mode (or in single fan deck: Circuit Immediate shutdown	NonLatch (or in single fan deck:Latch)	Prestart and Running w/Low Ambient Variable Spd Fan configured	A fault signal has been detected from the respective condenser's Variable Speed Inverter Drive (fan). Condenser Fan control will revert to constant speed operation without the use of the inverter's fan. If the inverter's fault clears, fan control will switch back to variable speed. For single fan deck configurations, this diagnostic causes a latching circuit shutdown.	
Fan Fault - Circuit 2	Circuit (fan control)	Special Mode (or in single fan deck: Circuit Immediate shutdown	NonLatch (or in single fan deck:Latch)	Prestart and Running w/Low Ambient Variable Spd Fan configured	A fault signal has been detected from the respective condenser's Variable Speed Inverter Drive (fan). Condenser Fan control will revert to constant speed operation without the use of the inverter's fan. If the inverter's fault clears, fan control will switch back to variable speed. For single fan deck configurations, this diagnostic causes a latching circuit shutdown.	
High Differential Refrigerant Pressure - Circuit 1	Circuit	Normal	Latch	Cprsr Energized	<b>High Vi Cprsr:</b> The differential pressure for the respective circuit was above 275 Psid (1890 kPa) for 2 consecutive samples or more than 10 seconds. <b>Low Vi Cprsr:</b> The system differential pressure was above 188 Psid (1296.4 kPa) - for 2 consecutive samples or more than 10 seconds.	Remote
High Differential Refrigerant Pressure - Circuit 2	Circuit	Normal	Latch	Cprsr Energized	<b>High Vi Cprsr:</b> The differential pressure for the respective circuit was above 275 Psid (1890 kPa) for 2 consecutive samples or more than 10 seconds. <b>Low Vi Cprsr:</b> The system differential pressure was above 188 Psid (1296.4 kPa) - for 2 consecutive samples or more than 10 seconds.	Remote
High Discharge Temperature – Compressor 1A	Circuit	Immediate	Latch	All [compressor run unload or compressor not running]	The compressor discharge temperature exceeded 200°F (without oil cooler) or 230°F (with oil cooler). This diagnostic will be suppressed during Run-Unload or after the compressor has stopped. Note: As part of the Compressor High Temperature Limit Mode (aka Minimum Capacity Limit), the compressor shall be forced loaded as the filtered discharge temperature reaches 190°F(without oil coolers), or 220°F (with oil coolers).	Remote



## Diagnosics

**Table 134. Main Processor Diagnostics (continued)**

Diagnostic Name	Affects Target	Severity	Persistence	Active Modes [Inactive Modes]	Criteria	Reset Level
High Discharge Temperature – Compressor 2A	Circuit	Immediate	Latch	All [compressor run unload or compressor not running]	The compressor discharge temperature exceeded 200°F (without oil cooler) or 230°F (with oil cooler). This diagnostic will be suppressed during Run-Unload or after the compressor has stopped. Note: As part of the Compressor High Temperature Limit Mode (aka Minimum Capacity Limit), the compressor shall be forced loaded as the filtered discharge temperature reaches 190°F (without oil coolers), or 220°F (with oil coolers).	Remote
High Evaporator Liquid Level – Circuit 1 (early Phase 1 RTWD production only – eliminated in 2nd Phase 1 release in Sept 08)	Circuit	Normal	Latch	Starter Contactor Energized [all Stop modes]	The liquid level sensor is seen to be at or near its high end of range for 80 contiguous minutes while the compressor is running. (The diagnostic timer will hold, but not clear when the circuit is off). Design: approx 80% or more of bit count corresponding to +30 mm or more liquid level for 80 minutes)	Remote
High Evaporator Liquid Level – Circuit 2 (early Phase 1 RTWD production only – eliminated in 2nd Phase 1 release in Sept 08)	Circuit	Normal	Latch	Starter Contactor Energized [all Stop modes]	The liquid level sensor is seen to be at or near its high end of range for 80 contiguous minutes while the compressor is running. (The diagnostic timer will hold, but not clear when the circuit is off). Design: approx 80% or more of bit count corresponding to +30 mm or more liquid level for 80 minutes)	Remote
High Evaporator Refrigerant Pressure	Chiller	Immediate	Non Latch	All	The evaporator refrigerant pressure of either circuit has risen above 190 psig. The evaporator water pump relay will be de-energized to stop the pump regardless of why the pump is running. The diagnostic will auto reset and the pump will return to normal control when all of the evaporator pressures fall below 185 psig. The primary purpose is to stop the evaporator water pump and its associated pump heat from causing refrigerant side pressures, close to the evaporator relief valve setting, when the chiller is not running, such as could occur with Evap Water Flow Overdue or Evaporator Water Flow Loss Diagnostics	Remote
High Evaporator Water Temperature	Chiller	Info and Special Action	Non Latch	Only effective if either 1)Evap Wtr Flow Overdue, 2)Evap Wtr Flow Loss, or 3)Low Evap Rfgt Temp,-Unit Off, diagnostic is active.	The leaving water temperature exceeded the high evap water temp limit (TV service menu settable – default 105F) for 15 continuous seconds. The evaporator water pump relay will be de-energized to stop the pump but only if it is running due one of the diagnostics listed on the left. The diagnostic will auto reset and the pump will return to normal control when the temperature falls 5°F below the trip setting. The primary purpose is to stop the evaporator water pump and its associated pump heat from causing excessive waterside temperatures and waterside pressures when the chiller is not running but the evap pump is on due to either Evap Water Flow Overdue, Evaporator Water Flow Loss, or Low Evap Temp – Unit Off Diagnostics. This diagnostic will not auto clear solely due to the clearing of the enabling diagnostic.	Remote
High Motor Temperature - Compressor 1A	Circuit	Immediate	Latch	All	The respective compressor’s motor winding thermostat is detected to be open	Local
High Motor Temperature - Compressor 2A	Circuit	Immediate	Latch	All	The respective compressor’s motor winding thermostat is detected to be open	Local

## Diagnostics

**Table 134. Main Processor Diagnostics (continued)**

Diagnostic Name	Affects Target	Severity	Persistence	Active Modes [Inactive Modes]	Criteria	Reset Level
High Pressure Cutout - Compressor 1A	Circuit	Immediate	Latch	All	A high pressure cutout was detected on Compressor 1A; trip at $270 \pm 5$ PSIG. Note: Other diagnostics that may occur as an expected consequence of the HPC trip will be suppressed from annunciation. These include Phase Loss, Power Loss, and Transition Complete Input Open. For Air Cooled Condenser, check for dirty coils or any fouling or restrictions as well as proper operation and rotational direction of all fans.	Local
High Pressure Cutout - Compressor 2A	Circuit	Immediate	Latch	All	A high pressure cutout was detected on Compressor 1A; trip at $270 \pm 5$ PSIG. Note: Other diagnostics that may occur as an expected consequence of the HPC trip will be suppressed from annunciation. These include Phase Loss, Power Loss, and Transition Complete Input Open. For Air Cooled Condenser, check for dirty coils or any fouling or restrictions as well as proper operation and rotational direction of all fans.	Local
High Refrigerant Pressure Ratio – Circuit 1	Circuit	Immediate	Latch	Service Pumpdown Only	The pressure ratio for the respective circuit exceeded 5.61 for 1 contiguous minute while in service pumpdown. This pressure ratio is a fundamental limitation of the compressor. The pressure ratio is defined as Pcond (abs) (Pevap(abs)).	Remote
High Refrigerant Pressure Ratio – Circuit 2	Circuit	Immediate	Latch	Service Pumpdown Only	The pressure ratio for the respective circuit exceeded 5.61 for 1 contiguous minute while in service pumpdown. This pressure ratio is a fundamental limitation of the compressor. The pressure ratio is defined as Pcond (abs) (Pevap(abs)).	Remote
LCI-C Software Mismatch: Use BAS Tool	Circuit	Info	Nonlatch	All	The neuron software in the LCI-C module does not match the chiller type. Download the proper software into the LCI-C neuron. To do this, use the Rover service tool, or a LonTalk® tool capable of downloading software to a Neuron 3150®.	Remote
Loss of Oil - Compressor 1A (Running)	Circuit	Immediate	Latch	Starter Contactor Energized	In running modes, Oil Loss Level Sensor detects lack of oil in the oil sump feeding the compressor (distinguishing a liquid flow from a vapor flow)	Local
Loss of Oil - Compressor 2A (Running)	Circuit	Immediate	Latch	Starter Contactor Energized	In running modes, Oil Loss Level Sensor detects lack of oil in the oil sump feeding the compressor (distinguishing a liquid flow from a vapor flow)	Local
Loss of Oil – Compressor 1A (Stopped)	Circuit	Immediate and Special Action	Latch	Compressor Pre-start [all other modes]	Oil Loss Level Sensor detects a lack of oil in the oil sump feeding the compressor for 90 seconds just prior to attempted compressor start. Note: Compressor start is delayed while waiting for oil to be detected, and compressor start is not allowed.	Local
Loss of Oil – Compressor 2A (Stopped)	Circuit	Immediate and Special Action	Latch	Compressor Pre-start [all other modes]	Oil Loss Level Sensor detects a lack of oil in the oil sump feeding the compressor for 90 seconds just prior to attempted compressor start. Note: Compressor start is delayed while waiting for oil to be detected, and compressor start is not allowed.	Local
Low Differential Refrigerant Pressure - Circuit 1	Circuit	Immediate	Latch	Cprsr Energized	The system differential pressure for the respective circuit was below 25 Psid (240.5 kPa) while its compressor was unstepped or pressure ratio was below 1.75 if stepped - for a varying period of time – refer to specification for trip time as a function of system DP below the requirement.	Remote

## Diagnostics

**Table 134. Main Processor Diagnostics (continued)**

Diagnostic Name	Affects Target	Severity	Persistence	Active Modes [Inactive Modes]	Criteria	Reset Level
Low Differential Refrigerant Pressure - Circuit 2	Circuit	Immediate	Latch	Cprsr Energized	The system differential pressure for the respective circuit was below 25 Psid (240.5 kPa) while its compressor was unstepped or pressure ratio was below 1.75 if stepped - for a varying period of time – refer to specification for trip time as a function of system DP below the requirement	Remote
Low Discharge Superheat – Circuit 1	Circuit	Normal	Latch	Any Running Mode	While Running Normally, the Discharge Superheat was less than 12 degrees F +- 1F for more than 6500 degree F seconds. At circuit startup the Discharge Superheat will be ignored for 5 minutes.	Remote
Low Discharge Superheat – Circuit 2	Circuit	Normal	Latch	Any Running Mode	While Running Normally, the Discharge Superheat was less than 12 degrees F +- 1F for more than 6500 degree F seconds. At circuit startup the Discharge Superheat will be ignored for 5 minutes.	Remote
Low Evaporator Refrigerant Pressure - Circuit 1	Circuit	Immediate	Latch	Cprsr Prestart and Cprsr Energized	a. The Evap Refrig Pressure dropped below 10 Psia just prior to compressor start (after EXV preposition). b. For RTUD A (C during early startup period: The Evap Refrig Pressure fell below the Condenser Pressure ÷ 8, limited to between 2 and 10 psia. c. For RTWD (or RTUD, ACFC=none) during early startup period: The Evap Refrig Pressure fell below 10 Psia. d. For all chiller types, after early Startup Period expires: The Evap Refrig Pressure fell below 16 Psia. (Note: the Startup Period for RTWD is 3 min ; for RTUD it is between 1 and 5 min for as an inverse function of the Cond Temp measured at time of circuit startup).	Local
Low Evaporator Refrigerant Pressure - Circuit 2	Circuit	Immediate	Latch	Cprsr Prestart and Cprsr Energized	a. The Evap Refrig Pressure dropped below 10 Psia just prior to compressor start (after EXV preposition). b. For RTUD A (C during early startup period: The Evap Refrig Pressure fell below the Condenser Pressure ÷ 8, limited to between 2 and 10 psia. c. For RTWD (or RTUD, ACFC=none) during early startup period: The Evap Refrig Pressure fell below 10 Psia. d. For all chiller types, after early Startup Period expires: The Evap Refrig Pressure fell below 16 Psia. (Note: the Startup Period for RTWD is 3 min; for RTUD it is between 1 and 5 min for as an inverse function of the Cond Temp measured at time of circuit startup).	Local
Low Evaporator Refrigerant Temperature - Circuit 1	Circuit	Immediate	Latch	All Ckt Running Modes	The inferred Saturated Evap Refrigerant Temperature (calculated from suction pressure transducer dropped below the Low Refrigerant Temperature Cutout Setpoint for 1125°F-sec (25°F-sec max rate) while the circuit was running. The minimum LRTC setpoint is -5°F (18.7 Psia) the point at which oil separates from the refrigerant. During the time that the trip integral is non zero, the unload solenoid(s) of the running compressors on the circuit, shall be energized continuously and the load solenoid shall be off. Normal load (unload operation will be resumed if the trip integral decays to zero by temps above the cutout setpoint. The integral is held nonvolatily though power down, is continuously calculated, and can decay during the circuit's off cycle as conditions warrant.	Remote

**Diagnostics**
**Table 134. Main Processor Diagnostics (continued)**

Diagnostic Name	Affects Target	Severity	Persistence	Active Modes [Inactive Modes]	Criteria	Reset Level
Low Evaporator Refrigerant Temperature - Circuit 2	Circuit	Immediate	Latch	All Ckt Running Modes	The inferred Saturated Evap Refrigerant Temperature (calculated from suction pressure transducer dropped below the Low Refrigerant Temperature Cutout Setpoint for 1125°F-sec (25°F-sec max rate) while the circuit was running. The minimum LRTC setpoint is -5°F (18.7 Psia) the point at which oil separates from the refrigerant. During the time that the trip integral is non zero, the unload solenoid(s) of the running compressors on the circuit, shall be energized continuously and the load solenoid shall be off. Normal load (unload operation will be resumed if the trip integral decays to zero by temps above the cutout setpoint. The integral is held nonvolatily though power down, is continuously calculated, and can decay during the circuit's off cycle as conditions warrant.	Remote
Low Evaporator Temp - Ckt 1: Unit Off	Evap Pump	Special Action	Non Latch	Unit in Stop Mode, or in Auto Mode and No Ckt's Energzd [Any Ckt Energzd]	The respective evap sat temp fell below the water temp cutout setting while the evap liquid level was greater than -36 mm for 150 <sup>o</sup> -sec degree F seconds while Chiller is in the Stop mode, or in Auto mode with no compressors running. Energize small Evap Circulating Pump (RTUD A (C) and Evap Water pump Relay (but only if "Evap Water Pump Diagnostic Override" setting is enabled) until diagnostic auto resets, then de-energize the circ pump and return to normal evap pump control. Automatic reset occurs when the derived evap sat temp rises 2°F (1.1°C) above the cutout setting for 1 minute or the liquid level is below -36.0 mm for 20 minutes, or any compressor restarts. OA temp is substituted for evap sat temp in case of invalidity. This diagnostic even while active, does not prevent operation of either circuit.	Remote
Low Evaporator Temp - Ckt 2: Unit Off	Evap (and circ) Pump	Special Action	Non Latch	Unit in Stop Mode, or in Auto Mode and No Ckts Energzd [Any Ckt Energzd]	The respective evap sat temp fell below the water temp cutout setting while the evap liquid level was greater than -36 mm for 150 <sup>o</sup> -sec degree F seconds while Chiller is in the Stop mode, or in Auto mode with no compressors running. Energize small Evap Circulating Pump (RTUD A (C) and Evap Water pump Relay (but only if "Evap Water Pump Diagnostic Override" setting is enabled) until diagnostic auto resets, then de-energize the circ pump and return to normal evap pump control. Automatic reset occurs when the derived evap sat temp rises 2°F (1.1°C) above the cutout setting for 1 minute or the liquid level is below -36.0 mm for 20 minutes, or any compressor restarts. OA temp is substituted for evap sat temp in case of invalidity. This diagnostic even while active, does not prevent operation of either circuit.	Remote
Low Evaporator Water Temp: Unit Off	Evap Pump	Special Action	Non Latch	Unit in Stop Mode, or in Auto Mode and No Ckt(s) Energzd [Any Ckt Energzd]	The leaving Evaporator water temp. fell below the leaving water temp cutout setting for 30 degree F seconds while the Chiller is in the Stop mode, or in Auto mode with no compressors running. Energize small Evap Circulating Pump (RTUD A (C) and Evap Water pump Relay (but only if "Evap Water Pump Diagnostic Override" setting is enabled) until diagnostic auto resets, then de-energize the circ pump and return to normal evap pump control. Automatic reset occurs when the temp rises 2°F (1.1°C) above the cutout setting for 30 minutes. This diagnostic even while active, does not prevent operation of either circuit.	Remote

## Diagnostics

**Table 134. Main Processor Diagnostics (continued)**

Diagnostic Name	Affects Target	Severity	Persistence	Active Modes [Inactive Modes]	Criteria	Reset Level
Low Evaporator Water Temp: Unit On	Chiller	Immediate and Special Action	Non Latch	Any Ckt[s] Energzd [No Ckt(s) Energzd]	The evaporator water temp. fell below the cutout setpoint for 30 degree F Seconds while the compressor was running. Automatic reset occurs when the temperature rises 2 °F (1.1°C) above the cutout setting for 2 minutes. This diagnostic shall not de-energize the Evaporator Water Pump Output.	Remote
Low Oil Flow - Compressor 1A	Circuit	Immediate	Latch	Cprsr Energized and Delta P above 15 Psid	The intermediate oil pressure transducer for this compressor was indicating an unacceptable oil pressure drop as a % of the available oil pressure to move oil, suggesting significantly reduced oil flow to the compressor. Possible root causes include oil line service valve closed or restricted, dirty or restricted oil filter, compressor oil line kepner valve malfunction, or plugged (restricted oil cooler (when present).	Local
Low Oil Flow - Compressor 2A	Circuit	Immediate	Latch	Cprsr Energized and Delta P above 15 Psid	The intermediate oil pressure transducer for this compressor was indicating an unacceptable oil pressure drop as a % of the available oil pressure to move oil, suggesting significantly reduced oil flow to the compressor. Possible root causes include oil line service valve closed or restricted, dirty or restricted oil filter, compressor oil line kepner valve malfunction, or plugged (restricted oil cooler (when present).	Local
MP Application Memory CRC Error	Chiller	Immediate	Latch	All Modes	Memory error criteria TBD	Remote
MP: Could not Store Starts and Hours	None	Info	Latch	All	MP has determined there was an error with the previous power down store. Starts and Hours may have been lost for the last 24 hours.	Remote
MP: Invalid Configuration	None	Immediate	Latch	All	MP has an invalid configuration based on the current software installed	Remote
MP: Non-Volatile Block Test Error	None	Info	Latch	All	MP has determined there was an error with a block in the Non-Volatile memory. Check settings.	Remote
MP: Non-Volatile Memory Reformat	None	Info	Latch	All	MP has determined there was an error in a sector of the Non-Volatile memory and it was reformatted. Check settings.	Remote
MP: Reset Has Occurred	None	Info	Non Latch	All	The main processor has successfully come out of a reset and built its application. A reset may have been due to a power up, installing new software or configuration. This diagnostic is immediately and automatically cleared and thus can only be seen in the Historic Diagnostic List in TechView	Remote
No Differential Refrigerant Pressure - Circuit 1	Circuit	Immediate	Latch	Compressor running on Circuit	The system differential pressure was below 7.7 Psid (53 kPa) for 6 seconds after the 11 seconds ignore time relative to cprsr (circuit startup had expired.	Remote
No Differential Refrigerant Pressure - Circuit 2	Circuit	Immediate	Latch	Compressor running on Circuit	The system differential pressure was below 7.7 Psid (53 kPa) for 6 seconds after the 11 seconds ignore time relative to cprsr (circuit startup had expired.	Remote
Oil Analysis Recommended - Ckt #1	Circuit	Info	Latch	"Service Messages" enabled	Diagnostic occurs when accumulated circuit operating hours since last initialized exceeds 2000 hours. Diagnostic can be manually cleared but will reoccur every month (720 hours on real time clock) as long as accumulator is not re-initialized.	Remote

## Diagnostics

**Table 134. Main Processor Diagnostics (continued)**

Diagnostic Name	Affects Target	Severity	Persistence	Active Modes [Inactive Modes]	Criteria	Reset Level
Oil Analysis Recommended – Ckt #2	Circuit	Info	Latch	"Service Messages" enabled	Diagnostic occurs when accumulated circuit operating hours since last initialized exceeds 2000 hours. Diagnostic can be manually cleared but will reoccur every month (720 hours on real time clock) as long as accumulator is not re-initialized.	Remote
Oil Filter Change Recommended – Cprsr 1A	Circuit	Info	Latch	"Service Messages" enabled	Diagnostic occurs only when "service messages" are enabled and when Oil Filter Life remaining falls below 5%. Diagnostic can be manually cleared but will reoccur every month real time (720 hours on real time clock) as long as the oil filter life remaining does not rise above 20% (through normal calculations or reinitializing) (Prior to RTUD Release in Fall of 09): Diagnostic occurs only when "service messages" are enabled and when average oil pressure drop exceeds 18%. Diagnostic can be manually cleared but will reoccur every month (720 hours on real time clock) as long as average pressure drop does not fall below 16%.	Remote
Oil Filter Change Recommended – Cprsr 2A	Circuit	Info	Latch	"Service Messages" enabled	Diagnostic occurs only when "service messages" are enabled and when Oil Filter Life remaining falls below 5%. Diagnostic can be manually cleared but will reoccur every month real time (720 hours on real time clock) as long as the oil filter life remaining does not rise above 20% (through normal calculations or reinitializing) (Prior to RTUD Release in Fall of 09): Diagnostic occurs only when "service messages" are enabled and when average oil pressure drop exceeds 18%. Diagnostic can be manually cleared but will reoccur every month (720 hours on real time clock) as long as average pressure drop does not fall below 16%.	Remote
Oil Pressure System Fault – Circuit 1	Circuit	Immediate	Latch	Starter Contactor Energized [all Stop modes]	The Intermediate Oil Pressure Transducer for this cprsr is reading a pressure either above its respective circuit's Condenser Pressure by 15 Psia or more, or below its respective Suction Pressure 10 Psia or more for 30 seconds continuously.	Local
Oil Pressure System Fault – Circuit 2	Circuit	Immediate	Latch	Starter Contactor Energized [all Stop modes]	The Intermediate Oil Pressure Transducer for this cprsr is reading a pressure either above its respective circuit's Condenser Pressure by 15 Psia or more, or below its respective Suction Pressure 10 Psia or more for 30 seconds continuously.	Local
Oil Pressure Transducer – Compressor 1A	Circuit	Immediate	Latch	All	Bad Sensor or LLID	Remote
Oil Pressure Transducer – Compressor 2A	Circuit	Immediate	Latch	All	Bad Sensor or LLID	Remote
Outdoor Air Temperature Sensor	Chiller	RTUD with ACFC?NONE-Normal Shutdown; OATS=INST-Special Action	Latch	All	Bad Sensor or LLID. If the outdoor temperature is used for CHW reset, there shall be no CHW reset. Apply slew rates per Chilled Water Reset spec. RTUD: if this diagnostic occurs, operational pumpdown will be performed regardless of the last valid temperature. For RTWD, if installed for low ambient lockout, there shall be no LA lockout .	Remote

## Diagnostics

**Table 134. Main Processor Diagnostics (continued)**

Diagnostic Name	Affects Target	Severity	Persistence	Active Modes [Inactive Modes]	Criteria	Reset Level
Pumpdown Terminated - Circuit 1	Circuit	Info	NonLatch	Service or Operational Pumpdown	Operational or Service Pumpdown cycle for this circuit was terminated abnormally due to excessive time (op pd only) or due to a specific set of diagnostic criteria – but w (o associated latching diagnostics . (RTWD max Operation Pumpdown = 2 min)	
Pumpdown Terminated - Circuit 2	Circuit	Info	NonLatch	Service or Operational Pumpdown	Operational or Service Pumpdown cycle for this circuit was terminated abnormally due to excessive time (op pd only) or due to a specific set of diagnostic criteria . (RTWD max Operation Pumpdown = 2 min)	
Pumpdown Terminated by Time - Circuit 1	Circuit	Info	NonLatch	Service Pumpdown	Service Pumpdown cycle for this circuit was terminated abnormally due to excessive time (RTWD max Service Pumpdown = 4 min).	Local
Pumpdown Terminated by Time - Circuit 2	Circuit	Info	NonLatch	Service Pumpdown	Service Pumpdown cycle for this circuit was terminated abnormally due to excessive time (RTWD max Service Pumpdown = 4 min).	Local
Software Error 1001: Call Trane Service	All functions	Immediate	Latch	All	A high level software watchdog has detected a condition in which there was a continuous 1 minute period of compressor operation, with neither Evaporator water flow nor a “contactor interrupt failure” diagnostic active. The presence of this software error message suggests an internal software problem has been detected. The events that led up to this failure, if known, should be recorded and transmitted to Trane Controls Engineering.	Local
Software Error 1002: Call Trane Service	All functions	Immediate	Latch	All	Reported if state chart misalignment in stopped or inactive state occurred while a compressor was seen to be operating and this condition lasted for at least 1 minute (cmprsr operation due to Service Pumpdown or with Contactor Interrupt Failure diagnostic is excluded). The presence of this software error message suggests an internal software problem has been detected. The events that led up to this failure, if known, should be recorded and transmitted to Trane Controls Engineering.	Local
Software Error 1003: Call Trane Service	All functions	Immediate	Latch	All	Reported if state chart misalignment occurred inferred from either the Capacity Control, Circuit, or Compressor State Machines remaining in the Stopping state for more than 3 minutes. The presence of this software error message suggests an internal software problem has been detected. The events that led up to this failure, if known, should be recorded and transmitted to Trane Controls Engineering.	Local
Starter Failed to Arm (Start – Cprsr 1A)	Circuit	Normal	Latch	All	Starter failed to arm or start within the allotted time (15 seconds).	Local
Starter Failed to Arm (Start – Cprsr 2A)	Circuit	Normal	Latch	All	Starter failed to arm or start within the allotted time (15 seconds).	Local
Starter Module Memory Error Type 1 - Starter 2A	None	Info	Latch	All	Checksum on RAM copy of the Starter LLID configuration failed. Configuration recalled from EEPROM.	Local
Starter Module Memory Error Type 1 Starter 1A	None	Info	Latch	All	Checksum on RAM copy of the Starter LLID configuration failed. Configuration recalled from EEPROM.	Local
Starter Module Memory Error Type 2 - Starter 1A	Circuit	Immediate	Latch	All	Checksum on EEPROM copy of the Starter LLID configuration failed. Factory default values used.	Local

**Table 134. Main Processor Diagnostics (continued)**

Diagnostic Name	Affects Target	Severity	Persistence	Active Modes [Inactive Modes]	Criteria	Reset Level
Starter Module Memory Error Type 2 - Starter 2A	Circuit	Immediate	Latch	All	Checksum on EEPROM copy of the Starter LLID configuration failed. Factory default values used.	Local
Starter Panel High Temperature Limit - Compressor 1A	Circuit	Immediate and Special Action	Non Latch	All	Starter Panel High Limit Thermostat (170°F) trip was detected. Compressor 1A is shutdown and inoperative until the thermostat resets. Note: Other diagnostics that may occur as an expected consequence of the Panel High Temp Limit trip will be suppressed from annunciation. These include Momentary Power Loss, Phase Loss, Power Loss, and Transition Complete Input for Compressor 1A.	Local
Suction Refrigerant Pressure Transducer - Circuit 1	Circuit	Immediate	Latch	All	Bad Sensor or LLID	Remote
Suction Refrigerant Pressure Transducer - Circuit 2	Circuit	Immediate	Latch	All	Bad Sensor or LLID	Remote
Unexpected Starter Shutdown	Circuit	Normal	Non latch	All Cprsr Running modes, Starting, Running and Preparing to Shutdown	The Starter module status reported back that it is stopped when the MP thinks it should be running and no Starter diagnostic exist. This diagnostic will be logged in the active buffer and then automatically cleared. This diagnostic could be caused by intermittent communication problems from the Starter to the MP, or due to misbinding.	NA
Very Low Evaporator Refrigerant Pressure - Circuit 1	Chiller	Immediate	Latch	All [compressor or circuit in manual lockout]	The respective circuit's evaporator pressure dropped below 80% of the current Low Evap Refrig Press Cutout setting (see above) or 8 psia, whichever is less, regardless of the running state of the circuit's compressor. If a given compressor or circuit is locked out, the suction pressure transducer(s) associated with it, will be excluded from causing this diagnostic.	Local
Very Low Evaporator Refrigerant Pressure - Circuit 2	Chiller	Immediate	Latch	All [compressor or circuit in manual lockout]	The respective circuit's evaporator pressure dropped below 80% of the current Low Evap Refrig Press Cutout setting (see above) or 8 psia, whichever is less, regardless of the running state of the circuit's compressor. If a given compressor or circuit is locked out, the suction pressure transducer(s) associated with it, will be excluded from causing this diagnostic.	Local

## Communication Diagnostics

### Notes:

1. The following communication loss diagnostics will not occur unless that input or output is required to be present by the particular configuration and installed options for the chiller.
2. Communication diagnostics (with the exception of "Excessive Loss of Comm" are named by the Functional Name of the input or output that is no longer being heard from by the Main Processor. Many LLIDs, such as the Quad Relay LLID, have more than one functional output associated with it. A comm loss with such a multiple function board, will generate multiple diagnostics. Refer to the Chiller's wiring diagrams to relate the occurrence of multiple

communication diagnostics back to the physical LLID boards that they have been assigned to (bound).



## Diagnostics

**Table 135. Communication Diagnostics**

Diagnostic Name	Affects Target	Severity	Persistence	Active Modes [Inactive Modes]	Criteria	Reset Level
Comm Loss: Chiller% RLA Output	Chiller	Info	Latch	All	Continual loss of communication between the MP and the Functional ID has occurred for a 30 second period.	Remote
Comm Loss: Cond Head Press Control Output	Chiller	Immediate	Latch	All	Continual loss of communication between the MP and the Functional ID has occurred for a 30 second period.	Remote
Comm Loss: Cond Rfgt Pressure, Circuit #1	Circuit	Immediate	Latch	All	Continual loss of communication between the MP and the Functional ID has occurred for a 30 second period.	Remote
Comm Loss: Cond Rfgt Pressure, Circuit #2	Circuit	Immediate	Latch	All	Continual loss of communication between the MP and the Functional ID has occurred for a 30 second period.	Remote
Comm Loss: Condenser Entering Water Temperature	Chiller	Info and Special Action	Latch	All	RTWD Only: Continual loss of communication between the MP and the Functional ID has occurred for a 30 second period. If chiller running, and condenser water regulating valve option installed, force valve to 100% flow.	Remote
Comm Loss: Condenser Leaving Water Temperature	Chiller	Info and Special Action	Latch	All	RTWD Only: Continual loss of communication between the MP and the Functional ID has occurred for a 30 second period. If Chiller is running in the heat mode of operation – normal shutdown, otherwise, informational only. Discontinue Min Capacity Limit forced cprsr loading due to Low DP in subsequent startups.	Remote
Comm Loss: Condenser Rfgt Pressure Output	Chiller	Info	Latch	All	Continual loss of communication between the MP and the Functional ID has occurred for a 30 second period.	Remote
Comm Loss: Condenser Water Flow Switch	Chiller	Immediate	Latch	All	RTWD only: Continual loss of communication between the MP and the Functional ID has occurred for a 30 second period.	Remote
Comm Loss: Condenser Water Pump Relay	Chiller	Normal	Latch	All	RTWD only: Continual loss of communication between the MP and the Functional ID has occurred for a 30 second period.	Remote
Comm Loss: Discharge Temperature Circuit 1, Cprsr 1A	Circuit	Normal	Latch	All	Continual loss of communication between the MP and the Functional ID has occurred for a 30 second period.	Remote
Comm Loss: Discharge Temperature, Circuit 2, Cprsr 2A	Circuit	Normal	Latch	All	Continual loss of communication between the MP and the Functional ID has occurred for a 30 second period.	Remote
Comm Loss: Electronic Expansion Valve, Circuit #1	Circuit	Normal	Latch	All	Continual loss of communication between the MP and the Functional ID has occurred for a 30 second period.	Remote
Comm Loss: Electronic Expansion Valve, Circuit #2	Circuit	Normal	Latch	All	Continual loss of communication between the MP and the Functional ID has occurred for a 30 second period.	Remote
Comm Loss: Emergency Stop	Chiller	Normal	Latch	All	Continual loss of communication between the MP and the Functional ID has occurred for a 30 second period.	Remote
Comm Loss: Evaporator Entering Water Temperature	Chiller	Normal	Latch	All	Continual loss of communication between the MP and the Functional ID has occurred for a 30 second period. Note: Entering Water Temp Sensor is used in EXV pressure control as well as ice making & CHW reset, so it must cause a unit shutdown even if Ice or CHW reset is not installed.	Remote
Comm Loss: Evaporator Leaving Water Temperature	Chiller	Normal	Latch	All	Continual loss of communication between the MP and the Functional ID has occurred for a 30 second period.	Remote

## Diagnostics

**Table 135. Communication Diagnostics**

Diagnostic Name	Affects Target	Severity	Persistence	Active Modes [Inactive Modes]	Criteria	Reset Level
Comm Loss: Evaporator Rfgr Liquid Level, Circuit #1	Circuit	Normal	Latch	All	Continual loss of communication between the MP and the Functional ID has occurred for a 30 second period.	Remote
Comm Loss: Evaporator Rfgr Liquid Level, Circuit #2	Circuit	Normal	Latch	All	Continual loss of communication between the MP and the Functional ID has occurred for a 30 second period.	Remote
Comm Loss: Evaporator Water Flow Switch	Chiller	Immediate	Latch	All	Continual loss of communication between the MP and the Functional ID has occurred for a 30 second period.	Remote
Comm Loss: Evaporator Water Pump Relay	Chiller	Normal	Latch	All	Continual loss of communication between the MP and the Functional ID has occurred for a 30 second period.	Remote
Comm Loss: Ext Noise Setback Command	None	Info	Latch	All	Continual loss of communication between the MP and the Functional ID has occurred for a 30 second period.	Remote
Comm Loss: External Auto (Stop	Chiller	Normal	Latch	All	Continual loss of communication between the MP and the Functional ID has occurred for a 30 second period.	Remote
Comm Loss: External Chilled (Hot Water Setpoint	External Chilled Water setpoint	Special Action	Latch	All	Continual loss of communication between the MP and the Functional ID has occurred for a 30 second period. Chiller shall discontinue use of the External Chilled Water Setpoint source and revert to the next higher priority for setpoint arbitration	Remote
Comm Loss: External Circuit Lockout, Circuit #1	Circuit	Special Action	Latch	All	Continual loss of communication between the MP and the Functional ID has occurred for a 30 second period. MP will nonvolatily hold the lockout state (enabled or disabled) that was in effect at the time of comm loss.	Remote
Comm Loss: External Circuit Lockout, Circuit #2	Circuit	Special Action	Latch	All	Continual loss of communication between the MP and the Functional ID has occurred for a 30 second period. MP will nonvolatily hold the lockout state (enabled or disabled) that was in effect at the time of comm loss	Remote
Comm Loss: External Current Limit Setpoint	External Current Limit setpoint	Special Action	Latch	All	Continual loss of communication between the MP and the Functional ID has occurred for a 30 second period. Chiller shall discontinue use of the External Current limit setpoint and revert to the next higher priority for Current Limit setpoint arbitration	Remote
Comm Loss: External Ice Building Command	Ice Making Mode	Special Action	Latch	All	Continual loss of communication between the MP and the Functional ID has occurred for a 30 second period. Chiller shall revert to normal (non-ice building) mode regardless of last state.	Remote
Comm Loss: Fan Control Relays, Circuit #1	Circuit	Normal	Latch	All	Continual loss of communication between the MP and the Functional ID has occurred for a 30 second period.	Remote
Comm Loss: Fan Control Relays, Circuit #2	Circuit	Normal	Latch	All	Continual loss of communication between the MP and the Functional ID has occurred for a 30 second period.	Remote
Comm Loss: Fan Inverter Fault, Circuit #1	Circuit (fan control)	Special Mode (or in single fan deck: Circuit Immediate shutdown)	Latch (or in single fan deck:Latch)	All	Continual loss of communication between the MP and the Functional ID has occurred for a 30 second period. Operate the remaining fans as fixed speed fan deck. For single fan deck configurations, this diagnostic causes a latching circuit shutdown	Remote
Comm Loss: Fan Inverter Fault, Circuit #2	Circuit (fan control)	Special Mode (or in single fan deck: Circuit Immediate shutdown)	Latch (or in single fan deck:Latch)	All	Continual loss of communication between the MP and the Functional ID has occurred for a 30 second period. Operate the remaining fans as fixed speed fan deck. For single fan deck configurations, this diagnostic causes a latching circuit shutdown	Remote

## Diagnostics

**Table 135. Communication Diagnostics**

Diagnostic Name	Affects Target	Severity	Persistence	Active Modes [Inactive Modes]	Criteria	Reset Level
Comm Loss: Fan Inverter Speed Command, Circuit #1	Circuit (fan control)	Special Mode (or in single fan deck: Circuit Immediate shutdown)	Latch (or in single fan deck:Latch)	All	Continual loss of communication between the MP and the Functional ID has occurred for a 30 second period. Operate the remaining fans as fixed speed fan deck. For single fan deck configurations, this diagnostic causes a latching circuit shutdown	
Comm Loss: Fan Inverter Speed Command, Circuit #2	Circuit (fan control)	Special Mode (or in single fan deck: Circuit Immediate shutdown)	Latch (or in single fan deck:Latch)	All	Continual loss of communication between the MP and the Functional ID has occurred for a 30 second period. Operate the remaining fans as fixed speed fan deck. For single fan deck configurations, this diagnostic causes a latching circuit shutdown	
Comm Loss: Female Step Load Compressor 1A	Circuit	Normal	Latch	All	Continual loss of communication between the MP and the Functional ID has occurred for a 30 second period.	Remote
Comm Loss: Female Step Load Compressor 2A	Circuit	Normal	Latch	All	Continual loss of communication between the MP and the Functional ID has occurred for a 30 second period.	Remote
Comm Loss: Heat (Cool Switch	Heat Mode	Special Action	Latch	All	Continual loss of communication between the MP and the Functional ID has occurred for a 30 second period. The external input shall revert to normal (cooling) request regardless of last state. Chiller mode shall follow "OR" arbitration for heating (cooling mode, i.e. If any of the remaining inputs (front panel of BAS) are requesting heat mode, then the chiller shall be in heat mode.	Remote
Comm Loss: High Pressure Cutout Switch, Cprsr 1A	Circuit	Immediate	Latch	All	Continual loss of communication between the MP and the Functional ID has occurred for a 30 second period.	Remote
Comm Loss: High Pressure Cutout Switch, Cprsr 2A	Circuit	Immediate	Latch	All	Continual loss of communication between the MP and the Functional ID has occurred for a 30 second period.	Remote
Comm Loss: Ice-Making Status	Ice-Machine	Special Action	Latch	All	Continual loss of communication between the MP and the Functional ID has occurred for a 30 second period. Chiller shall revert to normal (non-ice building) mode regardless of last state.	Remote
Comm Loss: Local BAS Interface	None	Special Action	Non Latch	All	Continual loss of communication between the MP and the Functional ID has occurred for a 30 second period. Use last valid BAS setpoints. Diagnostic is cleared when successful communication is established with the LonTalk LLID (LCIC) or BacNet LLID (BCIC).	Remote
Comm Loss: Male Port Load Compressor 1A	Circuit	Normal	Latch	All	Continual loss of communication between the MP and the Functional ID has occurred for a 30 second period.	Remote
Comm Loss: Male Port Load Compressor 2A	Circuit	Normal	Latch	All	Continual loss of communication between the MP and the Functional ID has occurred for a 30 second period.	Remote
Comm Loss: Male Port Unload Compressor 1A	Circuit	Normal	Latch	All	Continual loss of communication between the MP and the Functional ID has occurred for a 30 second period.	Remote
Comm Loss: Male Port Unload Compressor 2A	Circuit	Normal	Latch	All	Continual loss of communication between the MP and the Functional ID has occurred for a 30 second period.	Remote
Comm Loss: Motor Winding Thermostat Compressor 1A	Circuit	Normal	Latch	All	Continual loss of communication between the MP and the Functional ID has occurred for a 30 second period.	Remote
Comm Loss: Motor Winding Thermostat Compressor 2A	Circuit	Normal	Latch	All	Continual loss of communication between the MP and the Functional ID has occurred for a 30 second period.	Remote

## Diagnostics

**Table 135. Communication Diagnostics**

Diagnostic Name	Affects Target	Severity	Persistence	Active Modes [Inactive Modes]	Criteria	Reset Level
Comm Loss: Noise Setback Relay	None	Info	Latch	All	Continual loss of communication between the MP and the Functional ID has occurred for a 30 second period.	Remote
Comm Loss: Oil Loss Level Sensor Input – Circuit #1	Circuit	Normal	Latch	All	Continual loss of communication between the MP and the Functional ID has occurred for a 30 second period.	Remote
Comm Loss: Oil Loss Level Sensor Input – Circuit #2	Circuit	Normal	Latch	All	Continual loss of communication between the MP and the Functional ID has occurred for a 30 second period.	Remote
Comm Loss: Oil Pressure, Cprsr 1A	Cprsr	Immediate	Latch	All	Continual loss of communication between the MP and the Functional ID has occurred for a 30 second period.	Remote
Comm Loss: Oil Pressure, Cprsr 2A	Cprsr	Immediate	Latch	All	Continual loss of communication between the MP and the Functional ID has occurred for a 30 second period.	Remote
Comm Loss: Oil Return Gas Pump Drain – Circuit #1	Circuit	Normal	Latch	All	Continual loss of communication between the MP and the Functional ID has occurred for a 30 second period.	Remote
Comm Loss: Oil Return Gas Pump Drain – Circuit #2	Circuit	Normal	Latch	All	Continual loss of communication between the MP and the Functional ID has occurred for a 30 second period.	Remote
Comm Loss: Oil Return Gas Pump Fill – Circuit #1	Circuit	Normal	Latch	All	Continual loss of communication between the MP and the Functional ID has occurred for a 30 second period.	Remote
Comm Loss: Oil Return Gas Pump Fill – Circuit #2	Circuit	Normal	Latch	All	Continual loss of communication between the MP and the Functional ID has occurred for a 30 second period.	Remote
Comm Loss: Op Status Programmable Relays	None	Info	Latch	All	Continual loss of communication between the MP and the Functional ID has occurred for a 30 second period.	Remote
Comm Loss: Outdoor Air Temperature	Chiller	RTUD with ACFC?NONE - Normal Shutdown; OATS=INST-Special Action	Latch	All	Continual loss of communication between the MP and the Functional ID has occurred for a 30 second period. If the outdoor temperature is used for CHW reset, there shall be no CHW reset. Apply slew rates per Chilled Water Reset spec. For RTUD if this diagnostic occurs, operational pumpdown will be performed regardless of the last valid temperature. For RTWD, if installed for low ambient lockout, there shall be no lockout	Remote
Comm Loss: Starter 1A	Circuit	Immediate	Latch	All	Continual loss of communication between the MP and the Functional ID has occurred for a 30 second period.	Local
Comm Loss: Starter 2A	Circuit	Immediate	Latch	All	Continual loss of communication between the MP and the Functional ID has occurred for a 30 second period.	Local
Comm Loss: Starter Panel High Temperature Limit, Compressor 1A	None	Info	Latch	All	Continual loss of communication between the MP and the Functional ID has occurred for a 30 second period.	Local
Comm Loss: Suction Rfqt Pressure, Circuit #1	Circuit	Immediate	Latch	All [Ckt (Cprsr lock out)]	Continual loss of communication between the MP and the Functional ID has occurred for a 30 second period. Note: This diagnostic is replaced by diagnostic 5FB below with Rev 15.0	Remote
Comm Loss: Suction Rfqt Pressure, Circuit #2	Circuit	Immediate	Latch	All [Ckt (Cprsr lock out)]	Continual loss of communication between the MP and the Functional ID has occurred for a 30 second period. Note: This diagnostic is replaced by diagnostic 5FD below with Rev 15.0	Remote
Comm Loss:Evaporator Off-Cycle Freeze Protection Relay	None	Info	Latch	All	Continual loss of communication between the MP and the Functional ID has occurred for a 30 second period.	Remote

## Diagnostics

**Table 135. Communication Diagnostics**

Diagnostic Name	Affects Target	Severity	Persistence	Active Modes [Inactive Modes]	Criteria	Reset Level
Starter 1A Comm Loss: MP	Cprsr	Immediate	Latch	All	Starter has had a loss of communication with the MP for a 15 second period.	Local
Starter 2A Comm Loss: MP	Cprsr	Immediate	Latch	All	Starter has had a loss of communication with the MP for a 15 second period.	Local

**Table 136. Main Processor (Boot Messages and Diagnostics)**

DynaView Display Message	Description Troubleshooting
A Valid Configuration is Present	A valid configuration is present in the MP's nonvolatile memory. The configuration is a set of variables and settings that define the physical makeup of this particular chiller. These include: number (airflow, (and type of fans, number (and size of compressors, special features, characteristics, and control options. //Temporary display of this screen is part of the normal power up sequence.
An Invalid Configuration is Present	An invalid configuration has been detected in the Main Processor's nonvolatile memory and the MP is unable to proceed with the boot up. Communication via the service serial port is supported and the TechView service tool, (Configuration View), needs to be employed to correct the configuration.
App Present. Running Selftest... Selftest Passed	An application has been detected in the Main Processor's nonvolatile memory and the boot code is proceeding to run a check on its entirety. 8 seconds later, the boot code had completed and passed the (CRC) test. //Temporary display of this screen is part of the normal power up sequence.
App Present. Running Selftest... Err3: CRC Failure	An application has been detected in Main Processor's nonvolatile memory and the boot code is proceeding to run a check on its entirety. A few seconds later, the boot code had completed but failed the (CRC) test. //Connect a TechView Service Tool to the MP's serial port, provide chiller model number (configuration information) and download the configuration if prompted by TechView. Then proceed to download the most recent RTWD application or specific version as recommended by Technical Service. Note that this error display may also occur during the programming process, if the MP never had a valid application any time prior to the download. If the problem persists, replace the MP.
Boot Software Part Numbers: LS Flash --> 6200-0318-04 MS Flash --> 6200-0319-04	The "boot code" is the portion of the code that is resident in all MPs regardless of what application code (if any) is loaded. Its main function is to run power up tests and provide a means for downloading application code via the MP's serial connection. The Part numbers for the code are displayed in the lower left hand corner of the DynaView during the early portion of the power up sequence and during special programming and converter modes. See below. For the EasyView, the extension of the boot code part number is displayed for approximately 3 immediately following power up. //This is normal, but you should provide this information when contacting Technical Service about power up problems.
Converter Mode	A command was received from the Service Tool (Tech View) to stop the running application and run in the "converter mode". In this mode the MP acts as a simple gateway and allows the TechView service computer to talk to all the LLIDS on the IPC3 bus.
Err2: RAM Addr Test #1 Failure	There were RAM errors detected in RAM Address Test #1. //Recycle power, if error persists, replace MP.
Err2: RAM Addr Test #2 Failure	There were RAM errors detected in RAM Address Test #2. //Recycle power, if the error persists, replace MP.
Err2: RAM Pattern 1 Failure	There were RAM errors detected in RAM Test Pattern #1. //Recycle power, if the error persists, replace MP.
Err2: RAM Pattern 2 Failure	There were RAM errors detected in RAM Test Pattern #2. //Recycle power, if the error persists, replace MP.
Err4: UnHandled Interrupt Restart Timer: [3 sec countdown timer]	An unhandled interrupt has occurred while running the application code. This event will normally cause a safe shutdown of the entire chiller. Once the countdown timer reaches 0, the processor will reset, clear diagnostics, and attempt to restart the application and allow a normal restart of chiller as appropriate. //This condition might occur due to a severe electro-magnetic transient such as can be caused by a near lightning strike. Such events should be rare or isolated and if no damage results to the CH530 control system, the Chiller will experience a shutdown and restart. If this occurs more persistently it may be due to an MP hardware problem. Try replacing the MP. If replacement of the MP proves ineffective, the problem may be a result of extremely high radiated or conducted EMI. Contact Technical Service. If this screen occurs immediately after a software download, attempt to reload both the configuration and the application. Failing this, contact Technical Service.

## Diagnostics

**Table 136. Main Processor (Boot Messages and Diagnostics)**

DynaView Display Message	Description Troubleshooting
Err5: Operating System Error Restart Timer: [30 sec countdown timer]	An Operating System error has occurred while running the application code. This event will normally cause a safe shutdown of the entire chiller. Once the countdown timer reaches 0, the processor will reset, clear diagnostics, and attempt to restart the application and allow a normal restart of chiller as appropriate. //See Err 4 above
Err6: Watch Dog Timer Error Restart Timer: [30 sec countdown timer]	A Watch Dog Timer Error has occurred while running the application code. This event will normally cause a safe shutdown of the entire chiller. Once the countdown timer reaches 0, the processor will reset, clear diagnostics, and attempt to restart the application allowing a normal restart of chiller as appropriate.
Err7: Unknown Error Restart Timer: [30 sec countdown timer]	An unknown Error has occurred while running the application code. This event will normally cause a safe shutdown of the entire chiller. Once the countdown timer reaches 0, the processor will reset, clear diagnostics, and attempt to restart the application allowing a normal restart of chiller as appropriate
Err8: Held in Boot by User Key Press	The boot detected a key press in the center of the DynaView or both the + and – keys pressed on an EasyView while the MP was in the boot code. Upon seeing this message the user can use Techview to connect to the MP to perform a software download or another service tool function.
LCI-C Hardware Mismatch	The configuration currently in the nonvolatile memory has the LonTalk or BacNet communication option installed and the DynaView hardware does not contain adequate memory to support the option. The MP is unable to proceed with the boot up. Communication via the service serial port is supported and the TechView service tool, (Configuration View), needs to be employed to correct the configuration to remove the unsupported comm option and return to the previous configuration. The communication option can only be supported with MP hardware version -05 or newer.
No Application Present Please Load Application...	No Main Processor Application is present – There are no RAM Test Errors. //Connect a TechView Service Tool to the MP's serial port, provide chiller model number (configuration information) and download the configuration if prompted by TechView. Then proceed to download the most recent RTWD application or specific version as recommended by Technical Service.
Programming Mode	A command was received by the MP from the Tech View Service Tool and the MP is in the process of first erasing and then writing the program code to its internal Flash (nonvolatile) Memory. Note that if the MP never had a prior application already in memory, the error code "Err3" will be displayed instead of this, during the programming download process.
Software Error 1001: Call Trane Service	See item in Main Processor Diagnostics table above
Software Error 1002: Call Trane Service	See item in Main Processor Diagnostics table above
Software Error 1003: Call Trane Service	See item in Main Processor Diagnostics table above

## Limit Conditions

CH530 will automatically limit certain operating parameters to maintain optimum chiller performance and

prevent nuisance diagnostic trips. These limit conditions are noted in [Table 137](#).

**Table 137. Limit Conditions**

Running - Limited	The chiller, circuit, and compressor are currently running, but the operation of the chiller (compressor is being actively limited by the controls. Further information is provided by the sub-mode.
Capacity Limited by High Cond Press	The circuit is experiencing condenser pressures at or near the condenser limit setting. The compressor will be unloaded to prevent exceeding the limits.
Capacity Limited by High Current	The compressor is running and its capacity is being limited by high currents. The current limit setting is 120% RLA (to avoid overcurrent trips).
Capacity Limited by Low Evap Rfght Temp	The circuit is experiencing saturated evaporator temperatures at or near the Low Refrigerant Temperature Cutout setting. The compressors will be unloaded to prevent tripping.
Capacity Limited by Low Liquid Level	The circuit is experiencing low refrigerant liquid levels and the EXV is at or near full open. The compressor will be unloaded to prevent tripping.
Capacity Limited by Phase Unbalance	The compressor is running and its capacity is being limited by excessive phase current unbalance.

# Wiring Schematics

Table 138 provides a list of field wiring diagrams, electrical schematics and connection diagrams for RTWD and RTUD units. The complete wiring package is documented in RLC-SVE01\*-EN. A laminated wiring diagram booklet is also shipped with each unit.

## Unit Electrical Data

To determine the specific electrical characteristics of a particular chiller, refer to the nameplates mounted on the units.

**Table 138. RTWD (UD Wiring diagrams)**

<b>Drawing</b>	<b>Description</b>	
2309-7584	Sheet 1	Compressor - Ckt 1 (1A)
	Sheet 2	Compressor - Ckt 2 (2A)
	Sheet 3	Schematic - Wye-Delta Starter
	Sheet 4	Controls
	Sheet 5	Controls/LLID Bus
2309-7585	Sheet 1	Compressor - Ckt 1 (1A)
	Sheet 2	Compressor - Ckt 2 (2A)
	Sheet 3	Schematic - X-line Starters
	Sheet 4	Controls
	Sheet 5	Controls/LLID Bus
2309-7596	Sheet 1	Diagram
	Sheet 2	Unit Component Location
2309-7597	Sheet 1	Legend/Notes
	Sheet 2	Control Panel Component Location
2309-1913	Sheet 1	Diagram
	Sheet 2	Field Wiring
2309-1969	Sheet 1	Notes/Fuses
	Sheet 2	Interconnection Wiring, Field Wiring RTUD Paired Condenser
2309-7598	Sheet 1	Diagram
	Sheet 2	Field Layout
		Notes



Trane optimizes the performance of homes and buildings around the world. A business of Ingersoll Rand, the leader in creating and sustaining safe, comfortable and energy efficient environments, Trane offers a broad portfolio of advanced controls and HVAC systems, comprehensive building services, and parts. For more information, visit [www.Trane.com](http://www.Trane.com).

Trane has a policy of continuous product and product data improvement and reserves the right to change design and specifications without notice.

© 2012 Trane All rights reserved  
RLC-SVX09H-EN 01 Oct 2012  
Supersedes RLC-SVX09G-EN (May 2010)

We are committed to using environmentally  
conscious print practices that reduce waste.

