

Heating with Lower-Temperature Hot Water

Historically, many hot-water heating systems were designed for 180°F supply. Then, with the increased use of condensing boilers, many systems began to be designed for lower hot-water temperatures (e.g., 140°F) to increase boiler efficiency. Today, growing interest in decarbonization and electrification has increased the use of heat pumps or heat recovery for heating buildings; technologies that benefit from even lower hot-water temperatures.

This *Engineers Newsletter* examines how to select coils for these lower hot-water temperatures, in order to maximize the performance of these newer heating systems.

Today, sustainability is a key focus of many policy makers, businesses, and consumers. This has led to increased interest in reducing the carbon dioxide equivalent footprint of buildings, often referred to as **decarbonization**.¹ In the context of an HVAC system, decarbonization typically involves:

- Improving the energy efficiency of the overall system to reduce emissions from fuel combustion (either on site or at the power plant),
- Using refrigerants with a low Global Warming Potential (GWP) and minimizing leakage of these refrigerants, and
- Reducing the use of fossil fuels by installing electrified HVAC equipment served by an electrical grid that relies more heavily on carbon-free energy sources (e.g., solar, wind, and other renewables).

This latter strategy, often referred to as **electrification**, can present a challenge when a building requires heating.

Electrified Heating Solutions

A variety of electrified heating solutions are available, ranging from conventional resistance-based electric heat to heat pumps (either air-to-air or air-to-water) and heat recovery systems (which scavenge waste heat from a cooling process).

For hydronic heating systems—where electrified heating equipment is used to warm water for distribution throughout the building—a critical variable that affects the performance of the overall system is the hot-water supply (HWS) temperature.

To demonstrate, Figure 1 plots the minimum required heating efficiency of an air-to-water heat pump (AWHP), at outdoor temperatures of 17°F and 47°F, per Table 6.8.1-16 of ANSI/ASHRAE/IES Standard 90.1-2019.^{2,3} Note that a higher Coefficient of Performance, COP, is better.

Figure 1. Impact of HWS and outdoor temperatures on the heating COP of an air-to-water heat pump

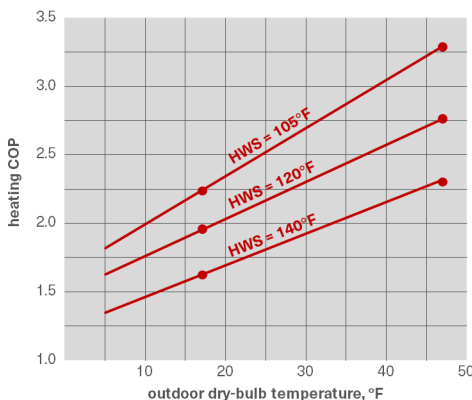
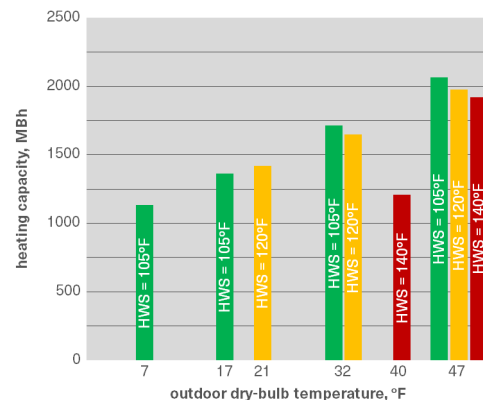

Figure 2. Impact of HWS and outdoor temperatures on the heating capacity of an air-to-water heat pump



And Figure 2 depicts the heating capacity of an example AWHP at various conditions.^{4,5}

These charts demonstrate how the COP and capacity of an air-to-water heat pump are impacted by both the outdoor air temperature and the HWS temperature:

- When the outdoor air is colder, the heat pump is less efficient (a lower heating COP) and its heating capacity is lower.
- When the hot-water supply temperature is reduced, the heat pump is more efficient (a higher heating COP) and its heating capacity is higher.

Therefore, a key strategy for raising the heating COP and increasing the capacity of this type of equipment—and reducing the negative impact of operating at colder outdoor temperatures—is to **design the heating system for a lower hot-water supply temperature.**

Impact of the Hot-Water Supply Temperature on Heating Coil Selection

While the choice of hot-water supply temperature also impacts the sizing and selection of piping, pumps, and valves, this EN focuses on how this choice impacts the selection of hot-water coils in the following types of HVAC equipment:

- VAV terminal units
- Multiple-zone VAV air-handling units
- Fan-coil units
- Dedicated (100-percent) outdoor air-handling units
- Single-zone VAV air-handling units

Zone-level terminal units, such as VAV terminal units and fan-coil units, often have fewer coil options than centralized air-handling units, so terminal units might have a greater influence on the final choice of the hot-water supply temperature.

VAV terminal units. When a zone requires heating, the hot-water coil in a single-duct VAV terminal unit heats the supply air to a temperature that is warmer than the zone.

At the example design heating condition depicted in Figure 3, the central air-handling unit delivers 325 cfm of 60°F primary air (PA) to this VAV terminal unit. (The discharge-air temperature from the centralized air-handling unit has been reset upward during cold weather, as required by Section 6.5.3.5 of ASHRAE® Standard 90.1.³) To offset the design heating load in the zone, the hot-water coil heats the supply air (SA) to 90°F, which requires a coil capacity of 10,600 Btu/h.

In hot-water heating systems designed for 180°F supply, one-row coils were often sufficient to provide the required capacity. However, when using a lower HWS temperature (such as 140°F or 105°F), VAV terminal units likely need to be equipped with multiple-row coils.

Figure 3. Example VAV terminal unit operating at design heating condition

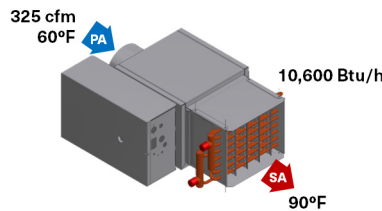

Table 1 compares the performance of an example VAV terminal unit, operating at this same design heating condition, selected for a HWS temperature of only 105°F:

- In this example, either a three- or four-row coil is needed to provide the required heating capacity.
- Providing the same capacity with a lower HWS temperature requires a higher fluid flow rate, which affects the size of pipes, pumps, and valves, and can also increase pumping energy use.
- Increasing from three to four rows allows for a reduction in both fluid flow rate and fluid pressure drop, but results in a slightly higher airside pressure drop, which impacts fan energy use.
- Upsizing the VAV terminal unit—from an 8-in. to a 10-in. inlet in this example—is a way to further minimize the impact on both pumping and fan energy use. Note that in some cases, upsizing the inlet diameter (diameter of VAV damper) may require using a higher minimum airflow setting to ensure proper controllability at the lowest airflows.

Table 1. Example VAV terminal unit selections⁵

Hot-water supply temperature	180°F	140°F	105°F	105°F	105°F	105°F
Coil rows	1	2	3	4	3	4
Inlet (VAV damper) diameter, in.	8	8	8	8	10	10
Coil heating capacity, Btu/h	10,600	10,600	10,600	10,600	10,600	10,600
Entering fluid temperature, °F	180	140	105	105	105	105
Leaving fluid temperature, °F	132	118	98	93	91	85
Fluid flow rate, gpm	0.44	0.95	3.27	1.71	1.52	1.05
Fluid pressure drop, ft. H ₂ O	0.66	0.10	1.13	0.45	0.70	0.51
Airside pressure drop at design cooling airflow, in. H ₂ O	0.23	0.43	0.63	0.83	0.31	0.41
Airside pressure drop at maximum heating airflow, in. H ₂ O	0.06	0.11	0.16	0.21	0.08	0.10

Note: Assumes airside pressure drop changes with the square of the airflow reduction—design cooling airflow = 650 cfm, minimum airflow = 130 cfm (165 cfm for 10-in. inlet diameter), maximum heating airflow = 325 cfm—using the “dual maximums” control sequence required by Section 6.5.2.1 of ASHRAE® Standard 90.1 (see sidebar on page 7).

Multiple-zone VAV air-handling units.

A hot-water coil located in the centralized air-handling unit of a multiple-zone VAV system is used to warm up the supply air during extremely cold weather, preventing air that is too cold from being delivered down the ductwork.

At the example design heating condition depicted in Figure 4, the central air-handling unit mixes 10°F outdoor air (OA) with 70°F air recirculated (RA) from the zones, resulting in a mixed-air (MA) temperature of 40°F. The hot-water coil in this air-handling unit warms this cold mixed air to 60°F, before delivering it down to the ductwork to the VAV terminal units.

Table 2 compares the performance of this example MZVAV hot-water coil, when selected for a HWS temperature of only 105°F:

- In this example, a one-row coil is still capable of providing the required heating capacity.
- Providing the same capacity with a lower HWS temperature requires a higher fluid flow rate, which affects the size of pipes, pumps, and valves, and can also increase pumping energy use.
- Increasing the number of coil fins—from 80 to 120 fins/ft in this example—allows for a reduction in both fluid flow rate and fluid pressure drop, but results in a slightly higher airside pressure drop, which impacts fan energy use.

If there is sufficient centralized exhaust or relief airflow, consider incorporating exhaust-air energy recovery. This technology transfers heat from the warm exhaust air to preheat the cold, incoming outdoor air, thereby reducing the capacity required of the centralized heating coil, or even eliminating the need for this coil altogether.

Table 2. Example multiple-zone VAV air-handling hot-water coil selections⁵

Hot-water supply temperature	180°F	140°F	105°F	105°F
Coil rows	1	1	1	1
Fin density, fins/ft	80	80	80	120
Coil heating capacity, Btu/h	86,800	86,800	86,800	86,800
Entering fluid temperature, °F	180	140	105	105
Leaving fluid temperature, °F	75	81	91	70
Fluid flow rate, gpm	1.65	2.92	12.8	5.00
Fluid pressure drop, ft. H ₂ O	0.15	0.41	5.51	1.10
Airside pressure drop of coil at design supply airflow, in. H ₂ O	0.091	0.091	0.091	0.121
Airside pressure drop of coil at design heating condition, in. H ₂ O	0.017	0.017	0.017	0.024

Note: Design supply airflow = 10,000 cfm, supply airflow at design heating condition = 4000 cfm

Figure 4. Example multiple-zone VAV air-handling unit operating at design heating condition

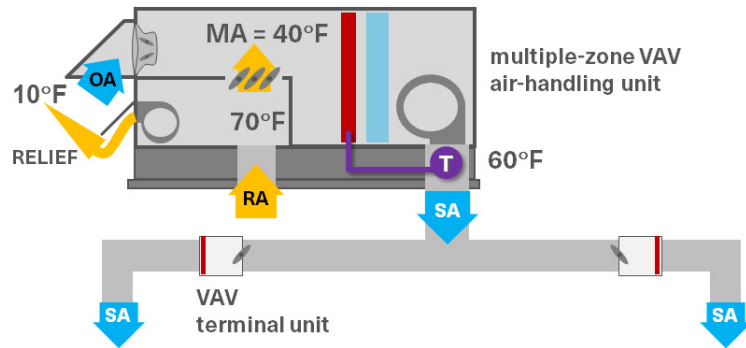

Fan-coil (or blower-coil) units. This is typically the most challenging application for lower hot-water supply temperatures, due to the limited availability of coil options and space constraints in this type of equipment, which is designed for installation in or near the occupied space.

As mentioned previously, when a heating system is designed for a lower HWS temperature, a hot-water coil might require more rows of tubes to provide the required heating capacity. Since chilled-water cooling coils are already constructed with multiple rows, consider configuring the fan-coil unit to use the same coil for both cooling and heating. This is often referred to as a **changeover coil**: when cooling is required chilled water passes through the tubes of the coil, but when heating is required hot water passes through those same tubes.

When used in a four-pipe distribution system—one set of pipes distributes chilled water to each fan-coil unit, while a separate set of pipes distributes hot water to each unit—a pair of diverting valves (or a special “six-way” valve) are used to enable this changeover (Figure 5).

Using the same (changeover) coil for both cooling and heating enables the use of a lower HWS temperature, while avoiding the additional cost and airside pressure drop of using separate, multiple-row coils.

Table 3 compares the performance of an example fan-coil unit, selected to heat 1200 cfm of 65°F recirculated air to a desired discharge-air temperature of 90°F, using a lower HWS temperature:

- In this example, additional coil rows are needed to provide the required heating capacity (see middle columns in the table). This also requires a higher fluid flow rate, which affects the size of pipes, pumps, and valves, and can increase pumping energy use.
- The far-right column in the table shows the performance of a single four-row changeover coil that is used for both cooling and heating. Having four rows of tubes available for heating allows this coil to provide the required heating capacity with a lower fluid flow rate and a lower fluid pressure drop. And, in this type of equipment, using a shared coil also allows more coil rows to be available for cooling.

In some cases, upsizing the fan-coil unit can be another way to enable the use of a lower HWS temperature.

A blower-coil is a special type of fan-coil unit that is designed specifically for ducted applications and higher capacities. This style of equipment often includes the option for more coil rows, which makes them well-suited for lower HWS temperatures.

Figure 5. Four-pipe distribution with a shared (changeover) heating/cooling coil (shown operating in heating mode)

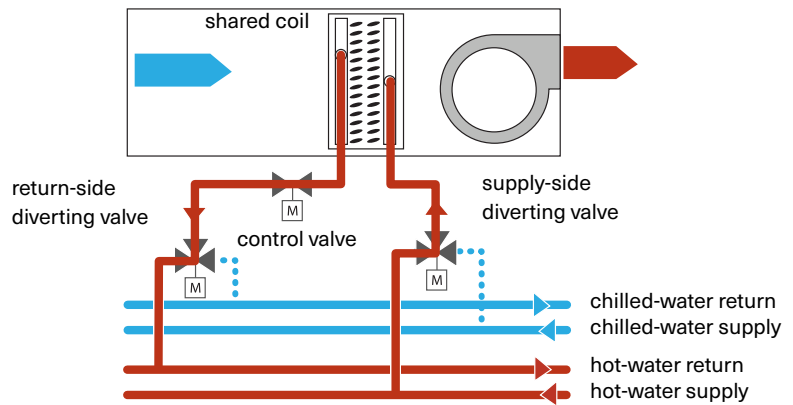

Table 3. Example fan-coil unit selections⁵

Hot-water supply temperature	180°F	140°F	110°F	105°F
Coil rows	1 (HW) 2 (CHW)	2 (HW) 2 (CHW)	2 (HW) 2 (CHW)	4 (changeover)
Coil heating capacity, Btu/h	32,600	32,600	32,600	32,600
Entering fluid temperature, °F	180	140	110	105
Leaving fluid temperature, °F	103	93	103	82
Fluid flow rate, gpm	0.85	1.39	9.06	2.83
Fluid pressure drop, ft. H ₂ O	4.32	0.84	28.2	2.91
Airside pressure drop of unit, in. H ₂ O	0.30	0.32	0.32	0.39

Dedicated (100-percent) outdoor air-handling units. In a dedicated outdoor-air system (DOAS), a hot-water coil located in the air-handling unit is used to heat cold outdoor air to a discharge-air temperature suitable for delivering to the zones—typically no warmer than 70°F.

Table 4 compares the performance of an example DOAS hot-water coil, selected to heat 5000 cfm of 10°F outdoor air to a desired discharge-air temperature of 70°F, using a HWS temperature of 105°F:

- In this example, additional coil rows are needed to provide the required heating capacity. This also requires a higher fluid flow rate, which affects the size of pipes, pumps, and valves, and can also increase pumping energy use.

- The far-right column in the table shows the performance of a single eight-row changeover coil, which is used for both cooling and heating. Having eight rows of tubes available for heating allows this coil to provide the required heating capacity with a lower fluid flow rate, a lower fluid pressure drop, and a lower overall airside pressure drop, since only a single coil is in the airstream.

Many dedicated outdoor-air systems include an exhaust-air energy-recovery device. As described previously, this reduces the capacity required of the heating coil in the dedicated outdoor air-handling unit.

Table 4. Example DOAS hot-water coil selections⁵

Hot-water supply temperature	180°F	140°F	105°F	105°F
Coil rows	2 (HW) 8 (CHW)	2 (HW) 8 (CHW)	4 (HW) 8 (CHW)	8 (changeover)
Coil heating capacity, Btu/h	325,000	325,000	325,000	325,000
Entering fluid temperature, °F	180	140	105	105
Leaving fluid temperature, °F	122	100	75	57
Fluid flow rate, gpm	11.3	16.3	21.7	13.5
Fluid pressure drop, ft. H ₂ O	0.39	0.78	0.41	0.30
Airside pressure drop of coil, in. H ₂ O	0.12 (HW) 1.21 (CHW)	0.15 (HW) 1.21 (CHW)	0.34 (HW) 1.21 (CHW)	1.21

Single-zone VAV air-handling units.

When a zone requires heating, the hot-water coil in a single-zone VAV air-handling unit heats the supply air to a temperature that is warmer than the zone.

Table 5 compares the performance of an example SZVAV hot-water coil, selected to heat 2000 cfm from 50°F to a desired discharge-air temperature of 90°F, using a HWS temperature of only 105°F:

- In this example, additional hot-water coil rows are needed to provide the required heating capacity. This also requires a higher fluid flow rate, which affects the size of pipes, pumps, and valves, and can also increase pumping energy use.
- The far-right column in the table shows the performance of a single six-row changeover coil, which is used for both cooling and heating. Having six rows of tubes available for heating allows this coil to provide the required heating capacity with a lower fluid flow rate, a slightly lower fluid pressure drop, and a lower overall airside pressure drop, since only a single coil is in the airstream.

As with the other air-handling unit configurations, incorporating exhaust-air energy recovery reduces the capacity required of the centralized heating coil.

Conclusion

Providing the necessary heating capacity with a lower hot-water supply (HWS) temperature requires a higher fluid flow rate, which increases the size and cost of pipes, pumps, and valves, and likely increases pumping energy use. However, a lower HWS temperature increases both the capacity and efficiency of the heating equipment, which reduces the size of this equipment and reduces heating energy use. Finding the right balance optimizes both installed cost and overall system energy use.

So what HWS temperature is needed to heat a building? As demonstrated, it varies based on the type of airside heating equipment. Table 6 summarizes typical ranges for the minimum HWS temperature, and the corresponding fluid ΔT , for various types of equipment.² This table also provides general recommendations when designing a heating system for a lower HWS temperature.

By John Murphy, Trane. To subscribe or view previous issues of the Engineers Newsletter visit trane.com. Send comments to ENL@trane.com.

Table 5. Example single-zone VAV air-handling unit hot-water coil selections⁵

Hot-water supply temperature	180°F	140°F	105°F	105°F
Coil rows	2 (HW) 6 (CHW)	2 (HW) 6 (CHW)	4 (HW) 6 (CHW)	6 (changeover)
Coil heating capacity, Btu/h	86,800	86,800	86,800	86,800
Entering fluid temperature, °F	180	140	105	105
Leaving fluid temperature, °F	150	120	85	81
Fluid flow rate, gpm	5.78	8.69	8.70	7.24
Fluid pressure drop, ft. H ₂ O	0.05	0.29	1.00	0.98
Airside pressure drop of coil, in. H ₂ O	0.13 (HW) 0.53 (CHW)	0.17 (HW) 0.53 (CHW)	0.39 (HW) 0.53 (CHW)	0.53

Table 6. General recommendations when designing a heating system for a lower hot-water supply temperature

Equipment type	Typical minimum HWS temperature	Expected fluid ΔT at minimum HWS temperature	General recommendations
VAV terminal units	100°F to 105°F	8°F to 20°F	<ul style="list-style-type: none"> Implement the “dual maximums” control sequence to allow for less-hot supply-air temperatures when heating (see sidebar below) Select hot-water coils with multiple rows Consider upsizing the VAV terminal unit
Multiple-zone VAV air-handling units	80°F to 105°F	18°F to 30°F	<ul style="list-style-type: none"> Include a centralized heating coil to avoid sending too cold of air down the ductwork to downstream VAV terminals Implement supply-air temperature reset during cold weather to reduce capacity required of hot-water coils in VAV terminal units Incorporate exhaust-air energy recovery to reduce capacity required of centralized heating coil (or eliminate this coil altogether)
Fan-coil or blower-coil units	95°F to 115°F	8°F to 30°F	<ul style="list-style-type: none"> Select hot-water coils with multiple rows Use a changeover coil Possibly consider upsizing the fan-coil unit
Dedicated outdoor air-handling units	80°F	20°F to 40°F	<ul style="list-style-type: none"> Consider using a changeover coil Incorporate exhaust-air energy recovery to reduce capacity required of DOAS heating coil
Single-zone VAV air-handling units	100°F to 105°F	12°F to 26°F	<ul style="list-style-type: none"> Consider using a changeover coil Incorporate exhaust-air energy recovery to reduce capacity required of centralized heating coil

“Dual maximums” VAV control sequence

Section 6.5.2.1 of ASHRAE® Standard 90.1 prescribes limits on reheating air that has been previously cooled.³ When a VAV terminal unit is equipped with direct digital controls (DDC), the standard allows the use of reheat if the “dual maximums” control sequence is used (Figure 6).

With this control sequence, when the zone temperature drops below the active heating setpoint (depicted on the left-hand side of the control mode chart), the controller modulates the hot-water valve to maintain zone temperature at the active heating setpoint, while the air damper maintains primary airflow at the minimum airflow setpoint. If the requested heating capacity has increased to the point where the discharge-air temperature reaches the design DAT limit (90°F in this case), the controller modulates the air damper (primary airflow), between the minimum airflow setpoint and maximum heating airflow setpoint, to maintain zone temperature at the active heating setpoint, while the hot-water valve modulates to maintain discharge-air temperature at this design DAT limit.

The standard allows this maximum heating airflow setpoint to be as high as 50 percent of the maximum cooling airflow. Higher airflow during heating prevents too hot of a discharge-air temperature, minimizing temperature stratification and short circuiting of warm air from overhead supply-air diffusers to ceiling-mounted return-air grilles. This improves occupant comfort and results in improved zone air-distribution effectiveness. And a lower discharge-air temperature when heating makes it easier to select hot-water coils with a lower hot-water supply temperature.

Figure 6. “Dual maximums” VAV control sequence

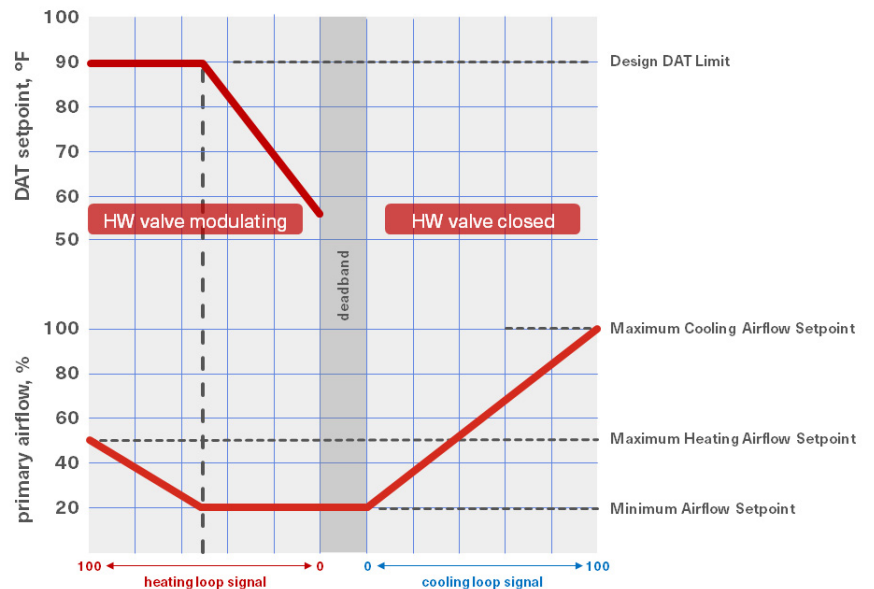

Note: This “dual maximums” control sequence requires a modulating hot-water valve (or modulating electric heater) and a discharge-air temperature sensor.

References

- [1] Van Fossen, E. 2022. "Introduction to Decarbonization in HVAC." Trane *Engineers Newsletter*, 51-2.
- [2] Trane®. *ACX Comprehensive Chiller-Heater System* application guide. SYS-APG003*-EN. 2022
- [3] ANSI/ASHRAE/IES. Standard 90.1-2019, *Energy Standard for Buildings Except Low-Rise Residential Buildings*. Atlanta: ASHRAE. 2019.
- [4] Trane. "Ascend® Air-to-Water Heat Pump (ACX)." www.trane.com/commercial.
- [5] Trane® Select Assist™ product selection program. www.traneselectassist.com.

2022 Engineers Newsletter *Live!* program schedule

MARCH

Applying VRF for a Complete Building Solution Part II. Now available online

MAY

Decarbonization of HVAC Systems Part II. Now available online

SEPTEMBER

Air-to-Water Heat Pump System Design. Building on the previous two Decarbonization of HVAC Systems ENLs, this program will cover electrified building heating systems utilizing air-to-water heat pumps. Topics covered will include operating characteristics of air-to-water heat pump equipment, system load and unit sizing considerations, system hot water design temperature considerations, system configurations and options including heat recovery, storage and auxiliary heat, as well as system control considerations.

NOVEMBER

Chillers and Heat Pumps with Energy Storage. Adding energy storage to buildings not only helps to save energy, energy costs and water, but it also saves carbon. In this program we will revisit the benefits and techniques for incorporating thermal energy storage for cooling. In addition, we will explore ways to use storage to minimize the impact that decarbonization of buildings and electrifying heat are expected to have on energy costs.

Contact your local Trane office for more information or visit www.Trane.com/ENL.



Trane – by Trane Technologies (NYSE: TT), a global climate innovator – creates comfortable, energy efficient indoor environments through a broad portfolio of heating, ventilating and air conditioning systems and controls, services, parts and supply. For more information, please visit trane.com or tranetechnologies.com.

Trane believes the facts and suggestions presented here to be accurate. However, final design and application decisions are your responsibility. Trane disclaims any responsibility for actions taken on the material presented.

All trademarks referenced in this document are the trademarks of their respective owners.